



INSTALLATION AND OPERATING INSTRUCTIONS

For Reliance Controls Emergency Power Transfer Switch Kit
Model Number 30216BRK



Congratulations on your purchase of the Reliance Controls Generator Power Transfer Switch Kit. Reliance has been manufacturing transfer switches and equipment in Racine, Wisconsin since 1983 and has been producing high-quality electrical equipment for nearly 100 years. Reliance is the Loadside® transfer switch used in nearly 90% of the installations done by professional electricians. Your transfer switch is UL 1008 listed, C-UL listed, and meets all requirements of the National Electrical Code.

The Reliance Controls transfer switch in this kit is made to operate with any generator up to 7500 watts continuous output, having 20 or 30 Amp twist-lock power receptacles.

TOOLS NEEDED FOR INSTALLATION

1. Power Drill
2. Wire Stripper and Cutter (10 to 14 gauge)
3. Insulated Screwdrivers
(#2 Phillips, ¼" Flat Tip or #2 Square Tip depending on your load center)
4. Hammer
5. Marking Pencil
6. Tape Measure
7. Four Wall Anchors with at Least a 3/8" Flange
8. Battery Powered Lighting during Installation
9. A Non-Contact Voltage Detector (optional)

PARTS LIST for 30216BRK TRANSFER SWITCH KIT

30 Amp 6-Circuit Transfer switch
30 Amp 20-foot long Generator Power Cord
20 Amp Interchangeable Power Cord Plug
6 yellow wire connectors
Installation and Operating Instructions
Installation and Operation Video

SAFETY SYMBOLS USED IN THIS MANUAL



Danger indicates an imminently hazardous situation that, if not avoided, could result in death or serious injury.



Warning indicates a potentially hazardous situation that, if not avoided, could result in death or serious injury.

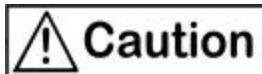

Caution indicates a potentially hazardous situation that, if not avoided, may result in minor or moderate injury.

Reliance Controls Corporation is not responsible for damage or injury caused by incorrect installation of this transfer switch.



Reliance transfer switches covered in this manual should not be used for electric water heaters, clothes dryers, electric ranges, central air conditioners or other appliances or systems that may exceed the capacity of the product.



Improper installation of the transfer switch could cause damage or personal injury by electrocution or fire. Installation must be performed by a qualified electrician, or others knowledgeable of electrical systems, in compliance with all applicable electrical codes.



When the transfer switch is connected to branch circuits with AFCI or GFCI breakers, the AFCI or GFCI protection will be lost when the toggle switch in the transfer switch is in the GEN position. To get AFCI or GFCI protection when running on generator power, it must be provided at the outlet(s).



Member of the National Electrical Manufacturers Association

ABOUT GENERATORS AND TRANSFER SWITCHES

Generators and transfer switches are dependent on one another as a system to power your home in a power out situation. The Reliance Controls transfer switch system is needed because 1) your portable generator is very powerful and the power it creates must be safely controlled to protect you and your electric utility provider, and 2) even with all of its power, your generator probably cannot power all of the electrical circuits and devices in your home without help from a transfer switch with load management capabilities.

The Reliance Controls transfer switch is designed to let you control and distribute your generator's power. It correctly distributes the power from your portable generator to your home circuitry through your electrical load center. It also eliminates the need for messy cords running to your electrical appliances through open doors and windows. The Reliance Controls transfer switch working with your generator takes the worry and inconvenience from power outage situations.

The Reliance Controls transfer switch distributes the power from your generator through its toggle switches to the corresponding selected branch circuits that power the major appliances you choose to operate during a power outage (such as your sump pump, refrigerator or furnace). However, because each of these branch circuits may power several other electrical devices other than your major appliances, such as the items plugged into wall sockets and permanently installed lighting, we recommend that you do a little pre-planning by:

1. Picking the key electrical appliances you want to power in an emergency
2. Finding the essential circuit breakers that control these devices
3. Creating a map of all of the other electrical devices plugged into or wired into these circuits

The circuit breaker label on the top of your transfer switch should be completed after installation to help you in managing the load on your generator.

During a power outage, you can run your generator and transfer switch system in two ways:

- You can set up your transfer switch to run all of its circuits at the same time once you flip the toggles to the GEN position. Setting your system up in this way will be discussed in the "Balancing the Load" section later.
- You can also use the load management function of the Reliance Controls transfer switch that allows you to alternate the devices you choose to run at any given time. If your generator is running at or near its maximum output, selected circuits can be switched off and others can be switched on for brief periods of time. For example, you can run a microwave oven for a brief period from the transfer toggle switch that controls your microwave circuit, if you first turn off the transfer switch toggle switch that controls your furnace—for that same brief period.

Example Generator and Transfer Switch Installation

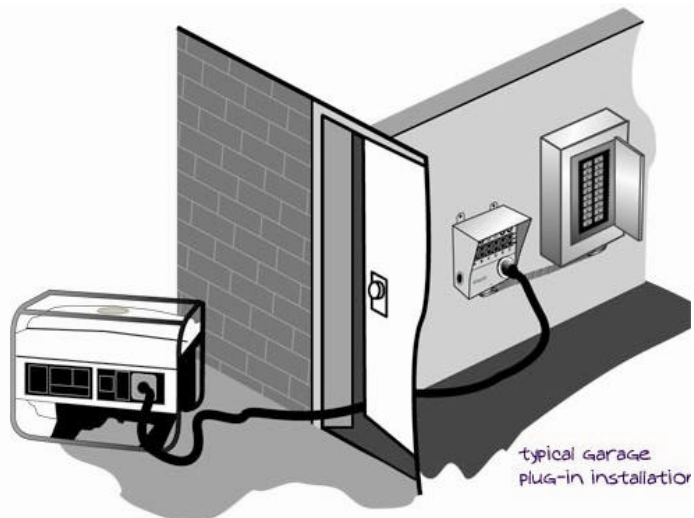

Generator Plugged into Power Inlet on Transfer Switch with 20-foot Cord

KEY COMPONENTS OF THE RELIANCE CONTROLS TRANSFER SWITCH KIT

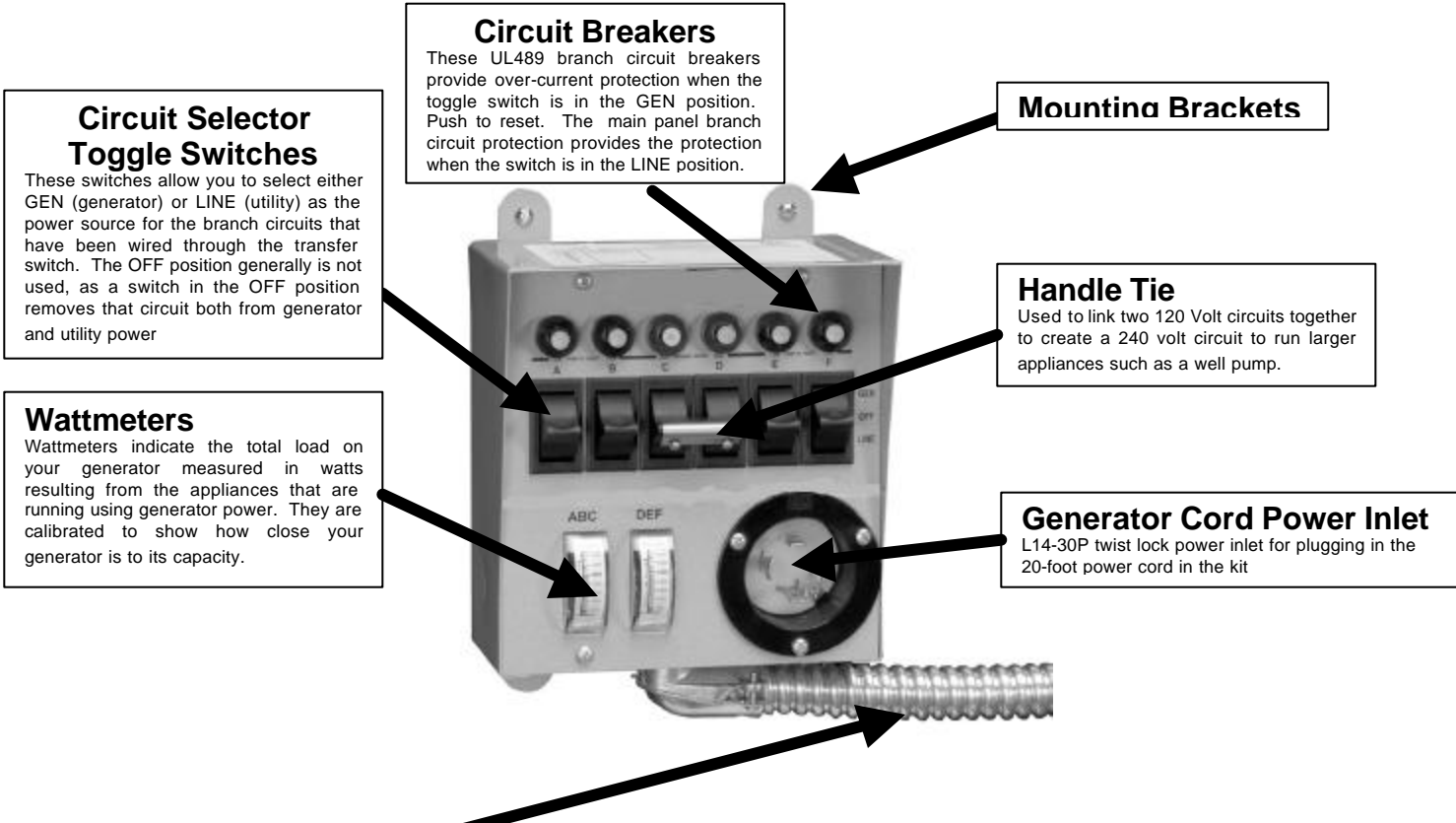

Circuit Breakers
These UL489 branch circuit breakers provide over-current protection when the toggle switch is in the GEN position. Push to reset. The main panel branch circuit protection provides the protection when the switch is in the LINE position.

Circuit Selector Toggle Switches
These switches allow you to select either GEN (generator) or LINE (utility) as the power source for the branch circuits that have been wired through the transfer switch. The OFF position generally is not used, as a switch in the OFF position removes that circuit both from generator and utility power

Wattmeters
Wattmeters indicate the total load on your generator measured in watts resulting from the appliances that are running using generator power. They are calibrated to show how close your generator is to its capacity.

Mounting Brackets

Handle Tie
Used to link two 120 Volt circuits together to create a 240 volt circuit to run larger appliances such as a well pump.

Generator Cord Power Inlet
L14-30P twist lock power inlet for plugging in the 20-foot power cord in the kit

Pre-Wired Flexible Conduit Whip
Contains all of the hot, neutral and ground wires required to make connections between your transfer switch and the circuit breakers in your load center you choose to control. Each wire is color-coded and marked with the switch letter for easy identification.



30 Amp Twist-Lock Power Cord

30 Amp 20-foot long outdoor-rated power cord has L14-30 connectors. One end plugs into your generator power outlet and the other into the Reliance Power Inlet Box.



20 Amp Interchangeable Power Cord Plug

Allows the use of the Reliance 30 Amp power cord on smaller generators with only 20 Amp power outlets, by replacing the 30 Amp plug on the cord supplied.

PRE-INSTALLATION PLANNING OF THE GENERATOR LOAD

Before you begin installing your Reliance Controls transfer switch, you need to create a plan for the appliances you choose to run during a power outage. To do this, it's helpful to first know how your generator produces power. If your generator has four-prong twist-lock 20 or 30 Amp output receptacles, and is set-up for home stand-by operation, it likely will produce 120/240 Volt power, or power similar to your electrical utility. This type of power generation is useful as it: 1) allows common 120 Volt circuits, such as lights or small appliances, to be operated, and 2) allows two 120 Volt circuits to be linked together to operate a 240 Volt device, such as a well pump.

Because of the way in which larger portable generators are designed, they generate power in two equal halves. A generator which has output of 5000 continuous running watts, for example, generates power from two 2500 watt "sides". In setting up a transfer switch to get the most power from your generator, it is desirable to "balance the load" between the two halves of your transfer switch, or the left side and the right side. Devices which will consume the most of the generator's wattage should be divided between the two sides. Load balancing is shown in Figure 1. For example, on the 6-circuit transfer switch shown in Figure 1, consider wiring the breaker controlling the refrigerator to toggle switch A, the furnace breaker to toggle switch B, the sump pump breaker to switch E and the breaker controlling your TV and VCR to toggle switch F. You may want to reserve switches C and D to be linked with a handle tie and wired to a double pole breaker controlling, for example, a 240 Volt well pump.

The Residential Wattage Requirements Table below shows sample wattages used by typical household appliances and can help you plan the set up of your transfer switch. Use the running watts of your appliances rather than starting watts when dividing them between the two halves of the transfer switch. Check your appliances for actual wattage requirements if possible.

Your Reliance Controls transfer switch also allows you to manage the load on your generator manually by switching appliances on and off as you need them, so the capacity of either half of your generator is not exceeded. However, if you prefer not to manage your transfer switch loads manually, leave a buffer equal to the largest start-up wattage requirement of all of the appliances you are going to run continually when doing your calculation. This buffer, along with the peak wattage of your generator, will allow for the periodic motor start-up of any one large appliance, such as your refrigerator. If your transfer switch is equipped with watt meters, you can visually monitor the amount of wattage being used by the appliances your generator is powering at any time.

Examples of load balancing calculations are shown on the worksheets on page 5. Use these to create your own plan.

TYPICAL RESIDENTIAL WATTAGE REQUIREMENTS

Appliance	Running Wattage	Additional Start-Up Wattage
Furnace (1/3 HP)	700	1,400
Furnace (1/2 HP)	875	2,100
Window Air Conditioner		
6000 BTU	1,200	2,100
12,000 BTU	1,700	2,900
Well Pump (1/3 HP)	750	1,400
Well Pump (1/2 HP)	1,000	2,350
Sump Pump (1/3 HP)	800	1,300
Sump Pump (1/2 HP)	1,050	2,150
Refrigerator	800	2,300
Garage Door Opener (1/4 HP)	550	1,100
Garage Door Opener (1/3 HP)	750	1,400
Home Security System	200	0
Lights	On Bulb	On Bulb
Stereo	200	0
TV / VCR	200	0
Computer	200	0
Microwave	Check oven	Check Oven
Coffee Maker	1,750	0
Toaster	1,300	0
Electric Fan	200	0
Clothes Washer	1,150	2,300
Clothes Dryer (Gas)	700	1,800
Dishwasher (Cool Dry)	700	1,400
Dishwasher (Hot Dry)	1,450	1,400
Vacuum Cleaner	1,000	0
Hair Dryer	Check Dryer	Check Dryer
Iron	1,200	0
Circular Saw	800	2,000

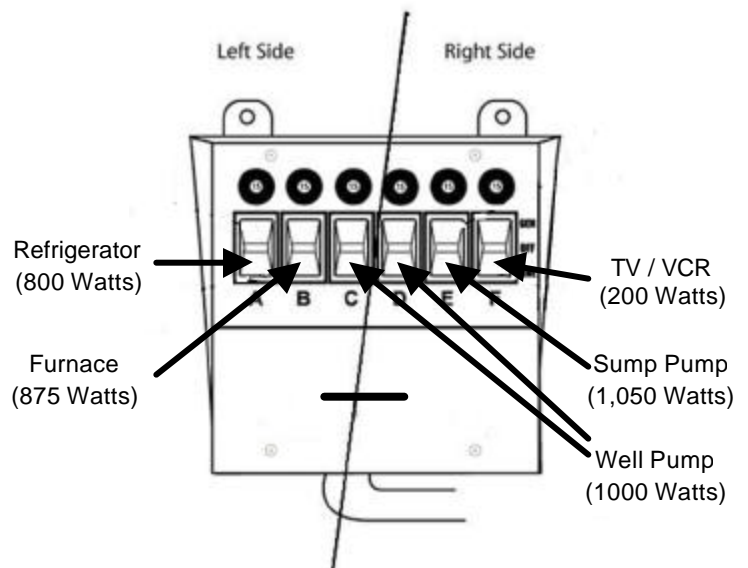

Figure 1

Load Balancing Example #1

Circuit Breaker Connections: Six (6) 120 Volt Single Pole Circuit Breakers
Generator: 5,500 Running Watts, 6,200 Peak Watts
Transfer Switch Model: 6-Circuits

Side One				Side Two			
Toggle Switch	Main Appliance Hooked Up	Appliance Running Watts	Additional Start-Up Watts	Toggle Switch	Main Appliance Hooked Up	Appliance Running Watts	Additional Start-Up Watts
A	Refrigerator	800	2,300	F	Furnace	700	1,400
B	Sump Pump	800	1,300	E	TV, VCR, Computer	600	0
C	Indoor Lighting	300	0	D	Security, Lighting	500	0
Total Running Watts Side One:				Total Running Watts Side Two:			
One: 1,900				Two: 1,800			

Total Side One and Side Two Running Watts **3,700**

Highest Additional Start-Up Wattage of all of the Appliances (Refrigerator) **2,300**

Total Watts of Load **6,000**

Peak Wattage Rating of Your Generator **6,200**

You're OK!

Load Balancing Example #2

Circuit Breaker Connections: Four (4) 120 Volt Single Pole Circuit Breakers and One (1) 240 Volt Double-Pole Circuit Breaker (Toggles C & D Together)
Generator: 5,500 Running Watts, 6,200 Peak Watts
Transfer Switch Model: 6-Circuits

Side One				Side Two			
Toggle Switch	Main Appliance Hooked Up	Appliance Running Watts	Additional Start-Up Watts	Toggle Switch	Main Appliance Hooked Up	Appliance Running Watts	Additional Start-Up Watts
A	Refrigerator	800	2,300	F	Furnace	700	1,400
B	TV, VCR, Computer	600	0	E	Sump Pump	800	1,300
C	Well Pump	500	1,175	D	Well Pump	500	1,175
Total Running Watts Side One:				Total Running Watts Side Two:			
One: 1,900				Two: 2,000			

Total Side One and Side Two Running Watts **3,900**

Highest Additional Start-Up Wattage of all of the Appliances (Refrigerator) **2,300**

Total Watts of Load **6,200**

Peak Wattage Rating of Your Generator **6,200**

You're OK Again!

INSTALLATION INSTRUCTIONS

A. Mounting the Transfer Switch

1. Position the transfer switch so that its bottom center is about 18 inches from the bottom center of your load center. The end of the flexible conduit whip should be lined up with a $\frac{3}{4}$ " or 1" knockout hole on the bottom of your load center. Select a $\frac{3}{4}$ " knockout for 4- and 6-circuit transfer switches, and a 1" knockout for 10-circuit transfer switches (Figure 2).
2. Mark the position of the holes on the four external feet with a pencil.
3. Anchor the transfer switch to the wall with four appropriate anchors (with a flange of at least $\frac{3}{8}$ ").

NOTE: Do not attempt to bend the flexible conduit whip beyond its structural capabilities.

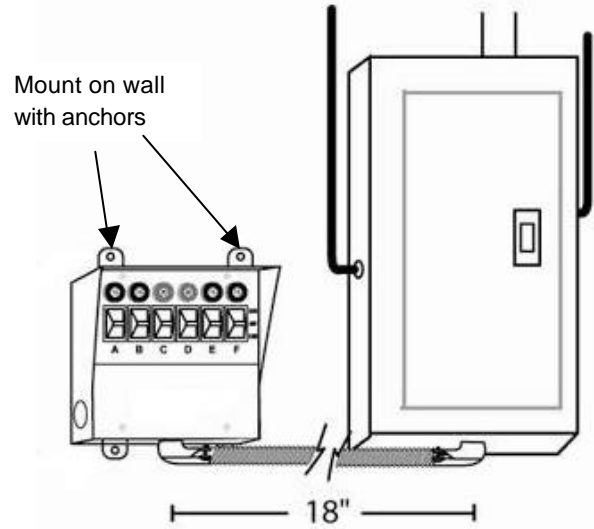
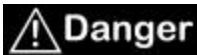

Figure 2

B. Connecting the Flexible Conduit Whip to Your Load Center

1. Set up battery-powered lighting to clearly illuminate your work area.
2. Turn off the main utility breaker (Figure 3).



Even with the main power switch turned off, the wires on the utility side of the main breaker are still live and contact with them can cause serious injury or death.

3. Remove the cover of your load center. Keep in mind that the wires on the utility side of the main breaker are still live and if contacted could cause serious injury or death. If available, use a non-contact voltage detector to insure that the power is off on the non-utility side of the main breaker.
4. Remove the appropriate knockout hole in the bottom of your load center with a screwdriver and hammer. (See step A-1 above.)
5. Insert all of the wires extending from the end of the flexible conduit whip through the knockout hole. Snap the conduit connector attached to the whip into the knockout hole.

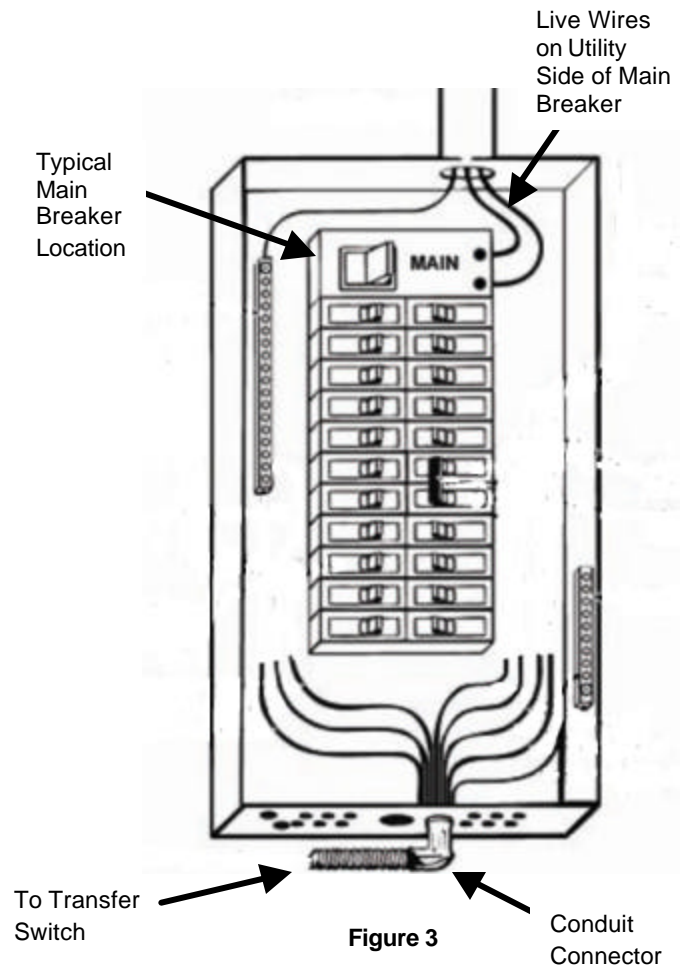

Figure 3

C. Connecting the Neutral and Ground Wire

1. Find the white wire (Neutral) and the green wire (ground) among the wires from the transfer switch that you have inserted into the load center.
2. Strip approximately 5/8" from the end of the white wire. Locate the neutral bar and partially unscrew a terminal screw on the bar. Insert the stripped end of the wire into the side of the bar under the screw and retighten the screw. (Figure 4)
3. Locate the ground bar. (It should be labeled.) Connect the green wire to the ground bar in the same way as in step #2. In service entrance load centers, the ground bar and neutral bar are frequently the same; if so, the ground and neutral wires can be connected to either.



Figure 4

D. Installing 120 Volt Circuits

This section provides instructions for connecting the wires from your transfer switch to the circuit breakers in your load center which control your appliances

You should refer to the load planning you did previously to insure that side #1 and side #2 of the transfer switch are balanced. Wire the circuits, starting with toggle Switch A.

If a selected circuit is part of a multi-wire branch circuit, insure the other branch circuit that shares the neutral is also connected to the transfer switch. The two circuits must be connected to opposing legs (phases) of the generator power and a handle tie must be installed on the switch handles so that both legs are transferred at the same time.

Warning Failure to properly install a multi-wire branch circuit could result in overloading the neutral wire.

If you will not be installing any 240 Volt or multi-wire circuits, remove the factory-installed handle tie(s) on the unit by loosening the setscrews on the tie.

Lets assume that, according to your load balancing plan, you will use Switch A to supply power to the refrigerator (Figure 5)

1. Turn off the refrigerator circuit breaker. Disconnect the wire that is attached to the circuit breaker.
2. Find the black and red wires from the transfer switch marked A
3. Cut the red wire at a length convenient for it to reach to the refrigerator circuit breaker. Strip 5/8" from the end of the wire. *Connect the red wire to the refrigerator circuit breaker* and retighten the screw on the breaker.
4. Cut the black wire from the transfer switch to a length convenient for attaching it to the wire you removed from the refrigerator circuit breaker in #1. Strip 5/8" from the end of the wire.
5. Insert both wires—the one removed from the refrigerator circuit breaker and the black wire for Switch A—into a yellow wire connector. Tighten the connection and push the connected wires back into the wiring compartment of the load center.

Warning When Installing 120 Volt Circuits

The transfer switch circuits with 20 Amp breakers must be connected only to branch circuits with 20 Amp breakers in the load center. Do not connect transfer switch circuits to any branch circuits greater than 20 Amps.

NOTE: The transfer switch circuits with 15 Amp breakers can be connected to branch circuits with either 15 or 20 Amp breakers in the load center.

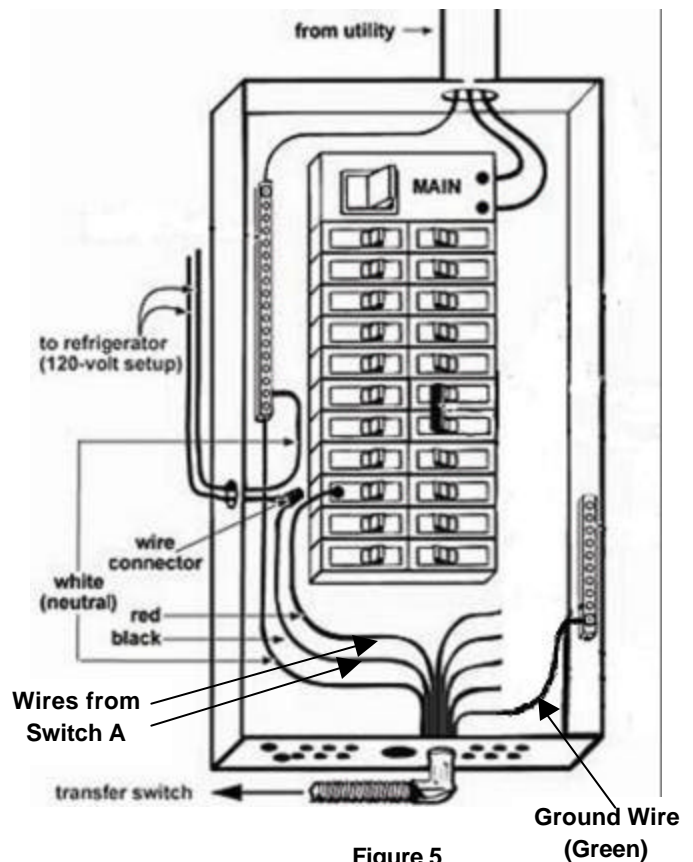

Figure 5

This completes the connection of Switch A for your refrigerator. Label Switch A as "REFRIGERATOR" on the identification pad on top of the transfer switch.

6. Repeat Steps 1 through 5 for each of the remaining switches on your transfer switch according to your load balancing plan, taking into account the following:
 - See the next section for installing 240-Volt Circuits
 - Remember to "Balance the Load", dividing appliances with higher wattages between the left and right side of the transfer switch

E. Installing 240 Volt Circuits

Reliance Controls 6-Circuit Transfer switch (In Kit) is shipped from the factory with one installed handle tie on the two middle switches C and D.

Let's assume that, according to your set-up plan, Switches C & D on the 6-Circuit transfer switch will be used to supply power to your well pump, a 240 Volt appliance. (Figure 6)

1. Find the two red and the two black wires marked C & D.
2. Turn off the double pole breaker for the well pump in the load center.
3. Disconnect the two installed wires on the double pole breaker.
4. Cut the two red wires from Switches C & D at a length convenient for them to reach to the double pole breaker. Strip 5/8" from the end of each red wire. Connect both **red** wires to the double pole **circuit breaker** in place of the wires you just removed from that breaker. It doesn't matter in what order.
5. Cut the black wires marked C & D to a length convenient to reach to the wires you removed from the double pole breaker in #3. Strip 5/8" from the end of each wire.
6. Connect one of the wires you removed from the double pole breaker in #3 with one of the black wires (either C or D) with a yellow wire connector. Similarly, connect the other wire you removed with the remaining black wire with a wire connector.

F. Completing the Installation of the Transfer Switch

When you have wired all of the circuits from the transfer switch into your load center and have properly installed the green and white wires to ground the unit, you have finished the installation. (Figure 7) Just a few more steps to wrap things up.

1. Replace the cover of the load center.
2. If you have not already done so, fill in the chart on the top of the transfer switch to identify your emergency circuits and the toggle switches they correspond to.

G. Finishing Up

After you have completed all the steps necessary in Sections A through F, complete the system installation by doing the following:

1. Turn on all of the circuit breakers in your load center.
2. Turn on the main breaker.
3. Position all switches on the transfer switch to the LINE position.
4. **IMPORTANT!** In order to insure that all wiring connections have been properly completed and that your system functions properly under generator power, it is important to test each circuit before turning on any devices or appliances connected to that circuit. Correct voltage output can and should be checked with a voltage meter at any convenient electrical outlet on each branch circuit that is wired through the transfer switch. This should be done under generator power with the appropriate circuit breaker switch in the "GEN" position.

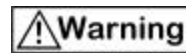

Warning When Installing 240 Volt Circuits

The transfer switch circuits with 20 Amp breakers must be connected only to branch circuits with 20 Amp breakers in the load center. Do not connect transfer switch circuits to any branch circuits greater than 20 Amps.

NOTE: The transfer switch circuits with 15 Amp breakers can be connected to branch circuits with either 15 or 20 Amp breakers in the load center.

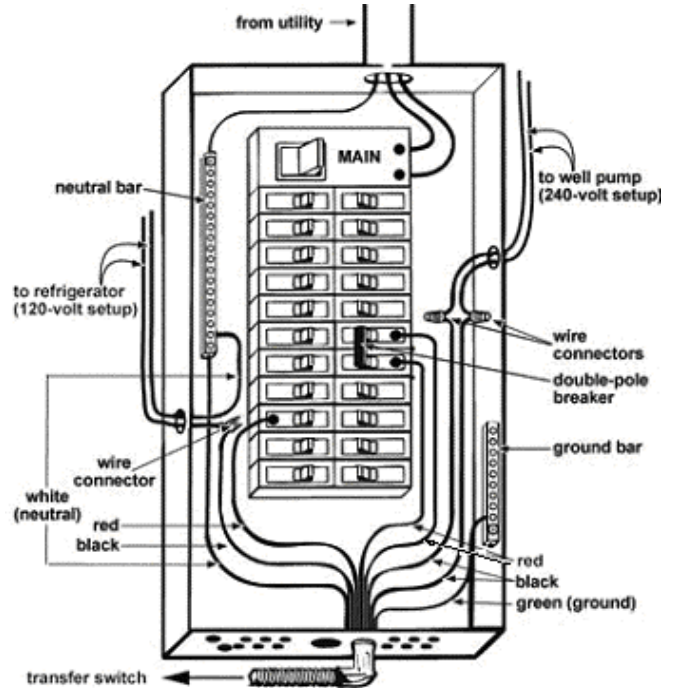

Figure 6

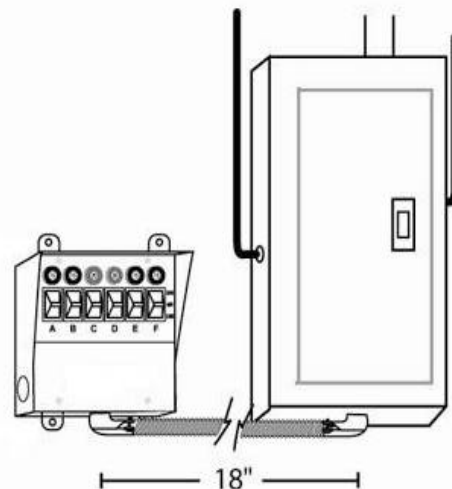

Figure 7

OPERATING INSTRUCTIONS



Warning Do not operate your generator in an enclosed

You want your generator to be ready when you need it -- so, it is important to perform the following steps once a month:

- Start and run generator power through your transfer switch circuits.
- Keep your fuel tank filled with fresh fuel.

With your Reliance Controls transfer switch installed, it is not necessary to turn off any of your load center breakers when starting your generator, even when utility power is fully functional. This is because the double throw break-before-make action of the transfer switch prevents feeding generator power to the utility and, conversely, prevents feeding utility power back to your generator.

A. Transferring from Utility Power to Generator Power in an Emergency

1. Make sure that all switches on the Reliance Controls transfer switch are in the LINE position.
2. Plug the male end of your power cord into the generator.
3. Plug the female end of your power cord into the transfer switch or the optional power inlet box (see below).
4. Start your generator outdoors and let it warm to a point where it is running evenly.
5. Turn the toggle switches on your Reliance transfer switch to the GEN position one at a time.
6. Monitor the wattage load on your generator using the wattmeters

B. Transferring back to Utility Power When the Power Is Restored

1. Move all switches on the Reliance Controls transfer switch back to the LINE position.
2. Turn off your generator.
3. Unplug your power cord and store it indoors.

OPTIONAL POWER INLET BOX

For some applications it may be desirable to connect the power cord from the generator to a power inlet box (not included in this Kit) that is located some distance away from the transfer switch (see Figure 8). For installation, refer to the manufacturer's instructions for both the power inlet box and the drop-cord connector. The connection to the transfer switch still must be made using the power inlet on the front of the transfer switch. As shown in Figure 8, this can be accomplished by installing a short drop cord to a junction box next to the transfer switch. Insure wiring meets all applicable codes including the proper wire sizes and strain relief for the short drop cord.

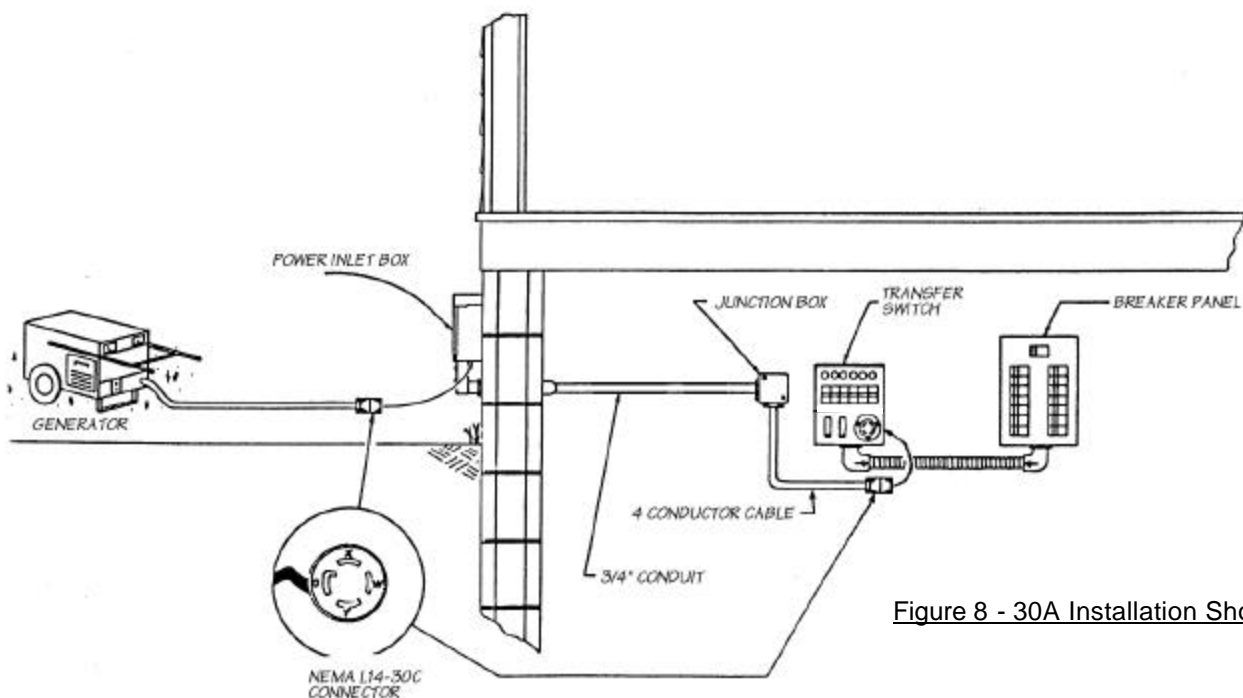

Figure 8 - 30A Installation Shown

OPTIONAL FLUSH KIT

This kit includes all the basic components to connect your generator to your household circuits but cannot be flush mounted without the optional flush kit shown below, which can be purchased separately,



TRANSFER SWITCH SPECIFICATIONS

Maximum Watts	7500
Possible Single Pole Connections	4 to 6
Possible Double Pole Connections	0 to 1
Maximum Combined Load @ 125 VAC	60 Amps
Maximum Combined Load @ 250 VAC	30 Amps
Maximum Load per Circuit from Generator	(2) 20 Amps, (4) 15 Amps
Maximum Load per Circuit from Load Center	20 Amps
Running Amps of Wattmeters	20mA
Cabinet Dimensions	7 ½" (H) x 7" (W) x 4 ½" (D)
Cabinet Type	NEMA 1 (Indoor)

FIVE-YEAR LIMITED WARRANTY

Reliance Controls Corporation ("Reliance") warrants this Manual Transfer Switch ("Switch") to be free from failure to perform as intended due to defects in materials and workmanship for a period of five (5) years from date of manufacture, provided the Switch has been installed and used in accordance with manufacturer's instructions and has not been subjected to misuse, alteration, accident, or repair not performed by Reliance. If, within such warranty period, the original purchaser gives written notice to Reliance at the address shown below and the Switch has been proven to Reliance's reasonable satisfaction to be defective, then Reliance at its sole option shall either: (i) supply a replacement component(s) for the defective component(s) or (ii) repair or replace the Switch. Reliance's obligation is strictly limited to said repair or replacement of the Switch, and Reliance shall not be liable for any incidental, special or consequential damages. The cost of labor to remove or install a replacement component or Switch is not included in this warranty. The foregoing warranty is exclusive and in lieu of all other expressed or implied warranties, if any, including but not limited to implied warranties of merchantability and fitness for a particular purpose. Reliance strongly recommends that the purchaser seek the advice of a licensed electrician to determine the suitability of this product, and for its proper installation in accordance with all applicable state and local building codes. This warranty gives you specific legal rights, and you may have other rights which vary from state to state.

Reliance Controls Corporation, 2001 Young Court, Racine, WI 53404, Attn: Warranty Claims Department



Reliance Controls Customer Service: (800) 439-5745
Website: www.reliancecontrols.com

2/15/05