



Revision 3 November 2023

Dealer Service Instructions for:

Safety Recall Y78 / NHTSA 21V-880

High Pressure Fuel Pump

NOTE: New parts ordering information added under Parts Information.

Effective immediately all repairs on involved vehicles are to be performed according to this recall. Service Bulletin (TSB) 18-054-21 Rev. A is no longer applicable for the vehicles involved in this recall. Those vehicles that have already had this repair performed, as determined by our warranty records, have been excluded from this recall.

Remedy Available

- 2019 - 2020 (D2) Ram 3500 Pickup**
- 2019 - 2020 (DD) Ram 3500 Cab Chassis**
- 2019 - 2020 (DJ) Ram 2500 Pickup**
- 2019 - 2020 (DP) Ram 4500/5500 Cab Chassis**

NOTE: This recall applies only to the above vehicles equipped with a 6.7L diesel engine.

NOTE: Some vehicles above may have been identified as not involved in this recall and therefore have been excluded from this recall.

IMPORTANT: Some of the involved vehicles may be in dealer new vehicle inventory. Federal law requires you to complete this recall service on these vehicles before retail delivery. Dealers should also consider this requirement to apply to used vehicle inventory and should perform this recall on vehicles in for service. Involved vehicles can be determined by using the VIP inquiry process.

Subject

The high pressure fuel pump (HPFP) on about 222,400 of the above vehicles may fail prematurely. A high pressure fuel pump failure may introduce internally failed component debris into the fuel system potentially causing fuel starvation. Vehicle occupants may notice a Malfunction Indicator Lamp illuminating, a fuel leak, abnormal engine noise, or a change in drive quality. Fuel starvation may result in an unexpected loss of motive power, which can cause vehicle crash without prior warning.

Repair

Vehicles delivered to the dealer in good running condition should complete HPFP replacement only. See Service Procedures A and B.

If the vehicle is brought to the dealer not running, the technician will follow the current diagnostic procedure to determine if there was an HPFP failure. If HPFP failure was determined, replacement of both the HPFP and in-tank fuel pump are required. The tank and fuel system will require cleaning. See Service Procedures A through C.

Alternate Transportation

Dealers should attempt to minimize customer inconvenience by placing the owner in a loaner vehicle if inspection determines that HPFP replacement and system cleaning is required and the vehicle must be held overnight.

Parts Information

Due to the significant quantity of vehicles and parts involved in this campaign, a STAR Case must be submitted in order to request parts.

Please access Cherwell via the Service Library link to create a STAR Case.

Please provide the VIN, Model Year and Family, Mileage and Dealer Code. Review the parts lists below and provide required parts list in STAR Case.

Important – When submitting a STAR Case-On the Repair Information Screen when selecting the “Next Step” – be sure to select “Y78 High Pressure Fuel Pump” from the list of options. This will route your ticket to the appropriate agent. DO NOT select “I will wait for STAR Response, or any other available option.

NOTE: Parts are packaged in kits. Please provide towing receipt and full kit replacement part number. It is expected that the unused parts are maintained for future vehicles requiring repair. **PLEASE CHECK YOUR DEALER INVENTORY PRIOR TO PROVIDING REQUIRED PARTS LIST TO STAR.**

Part Number Description

CSRLY781AA Fuel Pump Upfit Kit

Each package contains the following components:

<u>Quantity</u>	<u>Description</u>
1	68573988AA, Pump, Fuel (Cummins 568362)
1	68573990AA, Pilot Adapter (Cummins 5684299)
1	68573989AA, Fuel Pump Adapter (Cummins 5684301)
1	68573991AA, Jumper Harness (Cummins 5683566)
1	68573993AA, Fuel Pump Support (Cummins 5684303)
1	68573994AA, Threaded Spacer (Cummins 5685063)
1	68573995AA, Injector Fuel Supply Tube (Cummins 5684069)
1	68573996AA, Fuel Supply Tube (Cummins 5687735)
1	68573997AA, Fuel Drain Tube (Cummins 5684067)
1	68573999AA, Rail Plug (Cummins 5688160)
1	68574000AA, ECM Bracket (Cummins 5684423)
1	68573998AA, Connector, Quick Disconnect (Cummins 5688063)
1	68578594AA, Swivel Tie Mount (Cummins 5689139)
1	68359768AF, Power Steering Line (Cummins 5708745)
2	68578595AA, Bolt, Low Profile (Cummins 5689141)
2	04638665, Screw, Hex Flange Head (Cummins 3900678)
1	04429446, Hex Flange Head Screw (Cummins 3901446)
2	68578596AA, Screw, Socket Head Cap (Cummins 3420835)
1	04429114, Hex Flange Head Screw (Cummins 3902114)
1	04429630, Screw, Hex Flange Head (Cummins 3900630)
1	68444371AA, Seal, O Ring (Cummins 5362113)
1	69086175AA, Spring Washer (Cummins 5256193)
1	68533229AA, Quick Disconnect Connector (Cummins 5624797)
1	05086769AA, Hex Nut (Cummins 4890634)
3	68038172AA, Wire Tie (Cummins 3062329)
1	04429689, Nut (Cummins 3900589)

Parts Information [Continued]

For truck requiring tank replacement and fuel system cleaning, order one of the following.

CSRLY782AA Fuel Injector Kit H.O.

Each package contains the following components:

<u>Quantity</u>	<u>Description</u>
6	R8444790AA, Fuel Injectors (Cummins 5364204)
1	68447760AA , Fuel Rail (Cummins 5348915)
1	68479996AA, Fuel Line 1 (Cummins 5585171)
1	68479997AA, Fuel Line 2 (Cummins 5585172)
1	68479998AA, Fuel Line 3 (Cummins 5579140)
1	68479999AA, Fuel Line 4 (Cummins 5585174)
1	68480000AA, Fuel Line 5 (Cummins 5585175)
1	68480003AA, Fuel Line 6 (Cummins 5585176)
1	68417030AA, High Pressure Connector (Cummins 5473265)
1	68157291AA, Fuel Filter, On Engine (Cummins 5260529)
1	68436631AA, Fuel Filter, Chassis-mounted (Cummins 5708759)

CSRLY783AA Fuel Injector Kit S.O.

Each package contains the following components:

<u>Quantity</u>	<u>Description</u>
6	R8444791AA, Fuel Injectors (Cummins 5364205)
1	68447760AA, Fuel Rail (Cummins 5348915)
1	68479996AA, Fuel Line 1 (Cummins 5585171)
1	68479997AA, Fuel Line 2 (Cummins 5585172)
1	68479998AA, Fuel Line 3 (Cummins 5579140)
1	68479999AA, Fuel Line 4 (Cummins 5585174)
1	68480000AA, Fuel Line 5 (Cummins 5585175)
1	68480003AA, Fuel Line 6 (Cummins 5585176)
1	68417030AA, High Pressure Connector (Cummins 5473265)
1	68157291AA, Fuel Filter, On Engine (Cummins 5260529)
1	68436331AA, Fuel Filter, Chassis-mounted (Cummins 5708759)

Parts Information [Continued]

For truck requiring tank replacement and fuel system cleaning, order the following.

CSRLY78AAA Campaign Kit

Each package contains the following components:

<u>Quantity</u>	<u>Description</u>
2	69002992AA, Fuel Injector Banjo Washer
1	68005162AA, Gasket

<u>Part Number</u>	<u>Qty.</u>	<u>Description</u>
05145571AA	1	Pump – In-Tank Module (Lift Pump) DJ/D2 28 Gallon (Sales Code NFX) and 31 Gallon (Sales Code NFT)
68490266AA	1	Pump – In-Tank Module (Lift Pump) DJ/D2 50 Gallon (Sales Code NFC)
04560227AB	1	Pump – In-Tank Module (Lift Pump) DD/DP 22 Gallon (Sales Code NFA)
68084721AA	1	Pump – In-Tank Module (Lift Pump) DD/DP 52 Gallon (Sales Code NFH)
06506497AA	4	Bolts, Rear Drive Shaft (match to vehicle)
06509166AA	4	Bolts, Rear Drive Shaft (match to vehicle)

Parts Return

Render the recalled HPFP unusable and discard.

The fuel injectors will be subject to parts return. There is a core charge for the injectors. Follow the standard process for return.

Special Tools

The following special tools are required to perform this repair:

- NPN wiTECH MicroPod II
- NPN Laptop Computer
- NPN wiTECH Software
- 7471B Barring Tool
- 2065500140 Holder, Fuel Pump Gear
- 1023 Puller
- 9688A Cap Adapter, Power Steering Pump
- C-4207-A Vacuum Pump, Hand
- 8978A Decay Tool, Fuel
- 2065600140 Kit, Caps and Cover (Cummins)
- 9340 SAE Fuel Pump Lock Ring Wrench (Originally Shipped In Kit Number(s) 9327, 9327CC, 9397, 9575.
- 8978A Decay Tool, Fuel

Service Procedure

Vehicles delivered to the dealer in good running condition should complete HPFP replacement only. See Service Procedures A and B.

If the vehicle is brought to the dealer not running, the technician will follow the current diagnostic procedure to determine if there was an HPFP failure. If HPFP failure was determined, replacement of both the HPFP and in-tank fuel pump is required, including tank and fuel system cleaning. See Service Procedures A through C.

A. Remove the Original Pump

1. If the fuel system is contaminated, follow procedure **C. Remove, Clean and Install Fuel Tank Assembly** and procedure prior to HPFP replacement.
2. Open the hood.

NOTE: If the vehicle is equipped with an auxiliary battery, when disconnecting and isolating the negative battery cable for the 12-volt system, both batteries will need to be disconnected to power down the vehicle.

3. Disconnect the Intelligent Battery Sensor (IBS) wire harness connector (1) (Figure 1).

NOTE: Failure to disconnect the IBS wire harness connector can lead to damage of the IBS wire harness connector.

3. Loosen the ground terminal nut (2) and remove the negative battery cable with IBS from the battery and isolate it (Figure 1).

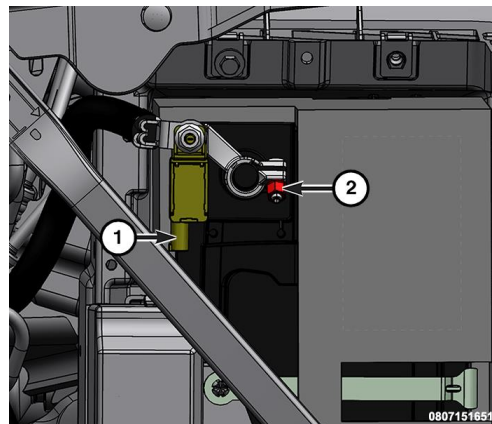

Figure 1 – Intelligent Battery Sensor (IBS)

4. If the vehicle is equipped with an auxiliary battery, loosen the clamp (1) and remove the clamp from the battery and isolate.

Service Procedure [Continued]

WARNING: No sparks, open flames or smoking. Risk of poisoning from inhaling and swallowing fuel. Risk of injury to eyes and skin from contact with fuel. Pour fuels only into suitable and appropriately marked containers. Wear protective clothing.

CAUTION: Cleanliness cannot be over emphasized when handling or replacing diesel fuel system components. This especially includes the fuel injectors, high-pressure fuel lines and fuel injection pump. Very tight tolerances are used with these parts. Dirt contamination could cause rapid part wear and possible plugging of fuel injector nozzle tip holes. This in turn could lead to possible engine misfire. Always wash/clean any fuel system component thoroughly before disassembly and then air dry. Cap or cover any open part after disassembly. Before assembly, examine each part for dirt, grease or other contaminants and clean if necessary.

NOTE: Be sure to cap or cover any part of the fuel system after disassembly using Protection Kit, Caps & Covers 2065600140.

5. Remove the oil dip stick (3) (Figure 2).
6. Remove the bolts (1) and the engine cover (2) (Figure 2).
7. Partially raise the vehicle.
8. Remove the left front wheel and tire.
9. Remove the screws (1), if equipped (Figure 3).
10. Remove the push-pin fastener (3) and remove the spat (2) (Figure 3).

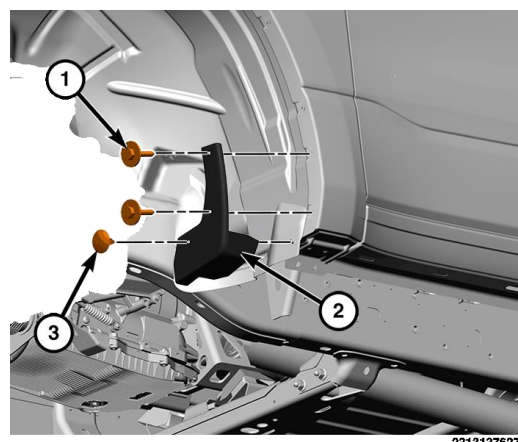
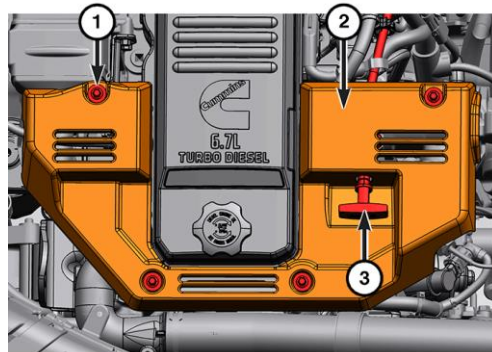

Figure 3 – Splash Shield Spat

Service Procedure [Continued]

11. Remove the splash shield screws (2) and the push-pins (1) (Figure 4).

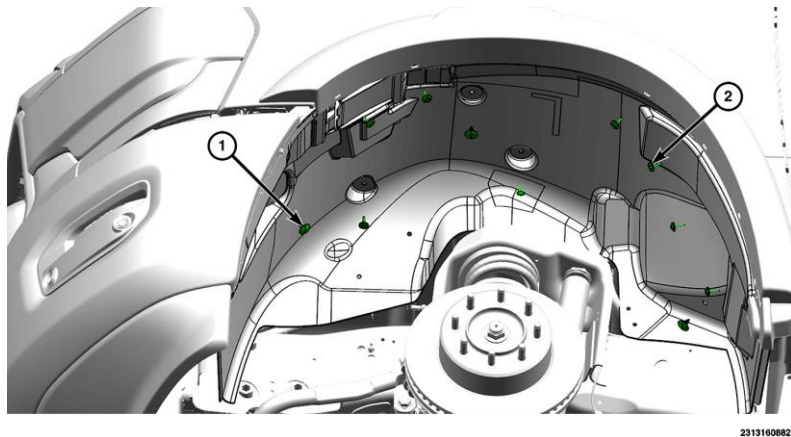

Figure 4 – Splash Shield

12. Remove the wheelhouse splash shield.
13. Loosen the clamp (1) and disconnect the left Charge Air Cooler (CAC) hose (2) from the cooler (Figure 5).

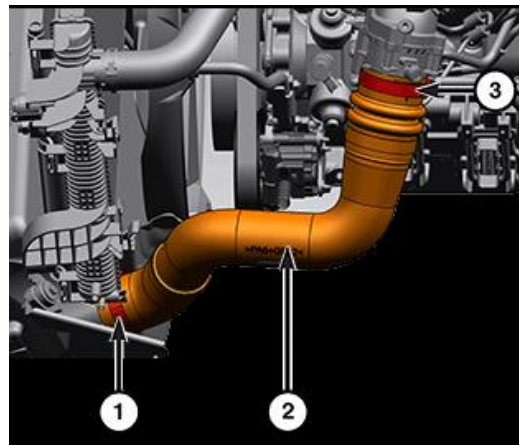

Figure 5 – Charge Air Cooler Hose

Service Procedure [Continued]

14. Loosen the clamp (3) and disconnect the left CAC hose (2) from the Exhaust Gas Recirculation (EGR) air flow control valve and remove it (Figure 75).
15. Using the 7471B, position the engine at TDC by rotating the crankshaft until the TDC mark on the vibration damper is at the 12 o'clock position.
16. Cut the cable tie and position aside the bulkhead connector (1) (Figure 6).
17. If equipped, remove the left generator (Refer to 08 – Electrical / 8F Engine System / Charging / GENERATOR / Removal and Installation).

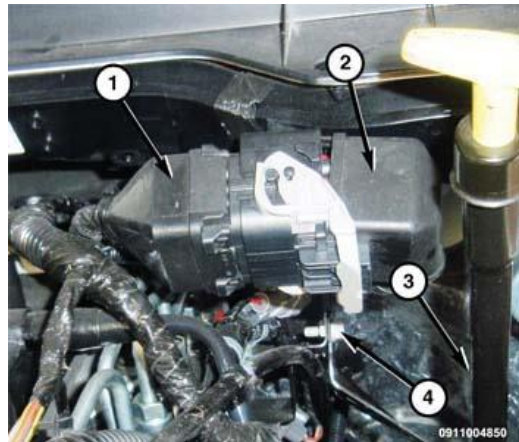

Figure 6 – Bulkhead Connector

18. Remove the Fuel Rail Noise Silencer (Figure 7).



Figure 7 – Fuel Rail Noise Silencer

Service Procedure [Continued]

19. Thoroughly clean rear of injection pump, and attachment points for its fuel lines. Also clean the opposite ends of these same lines at their attachment points.
20. Drain the engine mounted fuel filter.
21. Disconnect the low pressure supply (2) and return (3) lines from the fuel injection pump (Figure 8).
22. Disconnect the low pressure supply line (2) from the fuel filter housing and remove the line (Figure 8).
23. Disconnect the low pressure return line (3) from the fuel filter housing support bracket and remove the line (Figure 8).

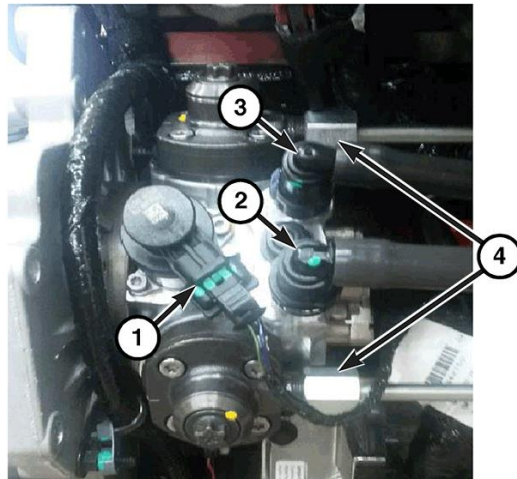
**Figure 8 – Fuel Supply Lines**

24. Remove electrical connectors from the exhaust pressure sensor, EGR cooler bypass, crankcase pressure sensor connectors 1 and 2, fuel injector wire harness, engine harness retainers, EGR temperature sensor, and reposition the harness aside.
25. Remove the fuel pressure sensor connector, CCV oil drain tube from the vehicle, and the injector silencer pad.
26. Remove both high pressure fuel injection pump to rail tube union nuts (4) from the fuel pump only (Figure 8).

Service Procedure [Continued]

27. Remove the nut (1) and bolt (7) securing the fuel tubes (16, 17). Reinstall bolt (7) (Figure 9).

28. Unscrew both high pressure fuel injection pump to fuel rail fuel tube union nuts and remove the fuel tubes (16, 17) (Figure 9).

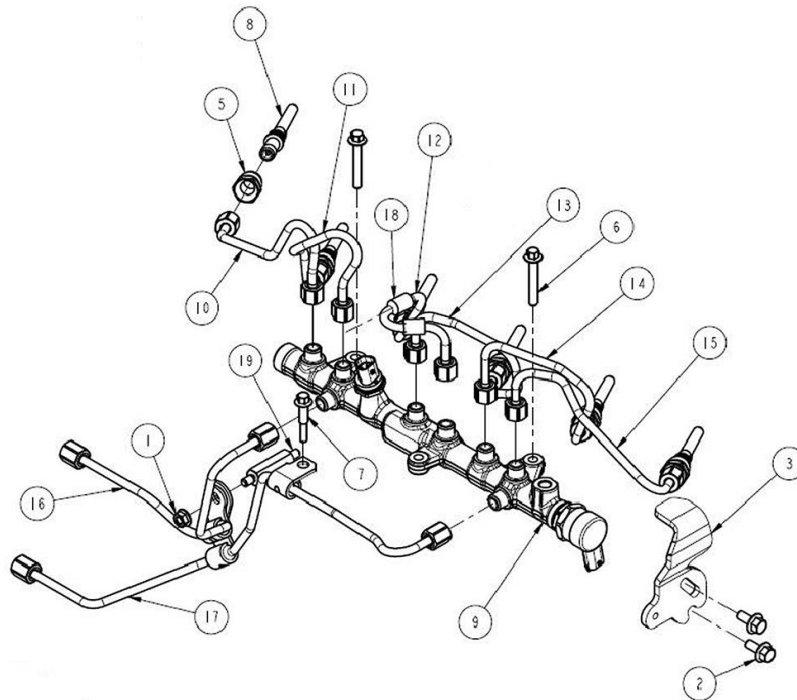

Figure 9 – HPFP Lines

NOTE: Using the Kit, Caps and Cover (Cummins) 2065600140, cap the fuel rail inlets with appropriately sized caps.

29. Position a drain pan under the power steering pump.

NOTE: Do not remove the fitting on the pump that the high pressure hose screws into. If the fitting does come loose, it must be retightened before continuing.

NOTE: If the fitting comes out of the pump body, the internal spring and valve parts will drop out of the pump. They cannot be reinstalled properly. Install a new pump.

Service Procedure [Continued]

30. Using a backer wrench to stabilize the fitting disconnect the pressure hose (4) to the power steering pump (1) and DISCARD the washers (Figure 10).
31. Disconnect the ECU harness and move it out of the way.

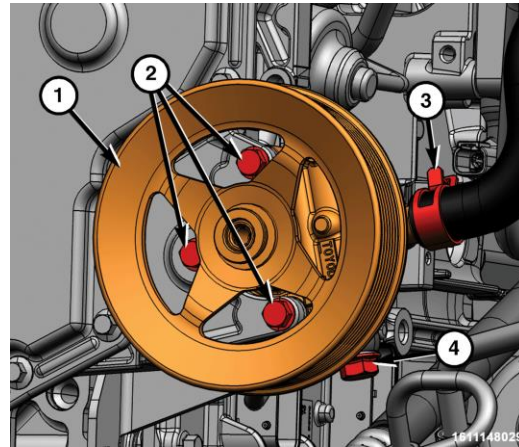

Figure 10 – Power Steering Pressure

32. Remove the nut (1) securing the engine harness to the fuel injection pump support bracket (Figure 11).
33. Remove engine harness clip from the studded fuel pump support bracket bolt and position harness to the side (Figure 11).

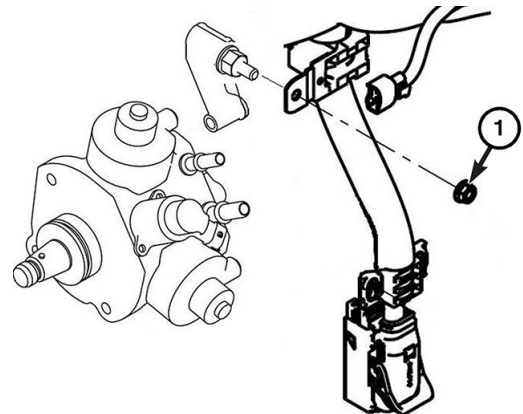

Figure 11 – HPFP Support Bracket Wiring

Service Procedure [Continued]

34. Remove fuel pump support bracket mounting bolts (2, 3), and remove bracket (1) (Figure 12).

NOTE: The gear (1) and pilot adapter (3) will remain on the pump shaft when removing from the housing.

NOTE: As the fuel injection pump is pulled away from the gear housing, the pilot adapter might separate from the pump, but the gear (1) will pull the adapter from the gear housing (2).

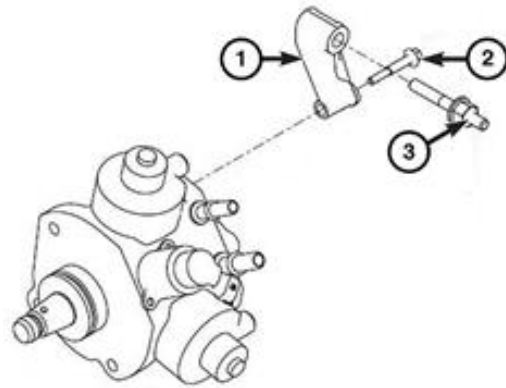

Figure 12 – HPFP Support Bracket

35. Remove the fuel injection pump mounting nuts (5), and remove the pump (4), pilot adapter (3), and gear (1) from the engine by pulling straight backwards on the pump. Make sure the fuel pump gear does not contact or damage the bore in the gear housing during removal (Figure 13).



Figure 13 – HPFP Removal

36. Using the Holder, Fuel Pump Gear 2065500140 (1), to hold fuel pump gear in place while removing the fuel pump gear mounting nut (2) and washer (Figure 14).

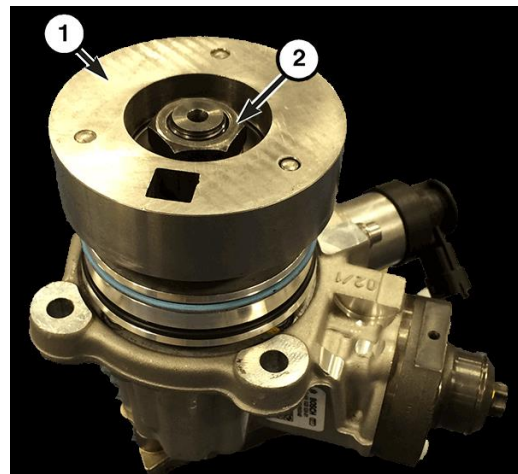
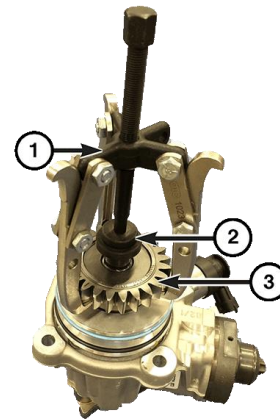

Figure 14 – Fuel Pump Gear Holder

Service Procedure [Continued]

37. Remove the fuel injection pump gear (3) using the Puller 1023 (1) and the Step Plate Adapter 8058 (2) (Figure 15).
38. Prepare the new fuel pump for installation.
 - a) Clean the pump gear and pump shaft at machined tapers with an evaporative type cleaner such as brake cleaner.
 - b) Inspect all mounting surfaces on the pump and engine for any nicks, cuts, or damage. Inspect O-ring surfaces for nicks, cuts, or damage.
 - c) Lubricate NEW O-ring (PN 5362113) (1) with engine oil and install onto the pilot adapter (Figure 16).
 - d) Lubricate NEW O-ring on the pump body with engine oil and then install the pilot adapter onto the pump body with the smaller diameter side towards the fuel pump. The adapter bottoms out internally, leaving a gap on the exterior (Figure 17).

NOTE: The pilot adapter will press on by hand.



14011262580

Figure 15 – Fuel Pump Gear Removal

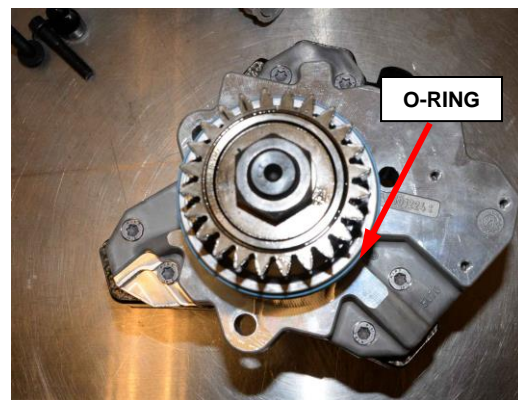

Figure 16 – Blue O-ring

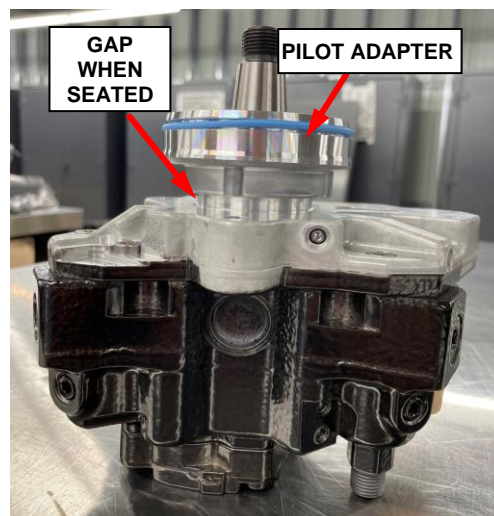

Figure 17 – Pilot Adapter

Service Procedure [Continued]

- e) Install the fuel pump gear onto the fuel pump shaft.
- f) Using a NEW fuel pump washer (PN 5256193), install washer and original nut (PN4890634) to pump shaft and tighten the nut finger tight only.
- g) Use the fuel pump gear holder to hold the fuel pump gear in place while tightening the fuel pump gear mounting nut to 105 N·m (77 ft. lbs.).
- h) Install the supply (3) and return (4) quick disconnect fittings onto the pump (Figure 18) as shown below and tighten to 24 N·m (18 ft. lbs.).
- i) Make sure engine cylinder 1 is at TDC position.

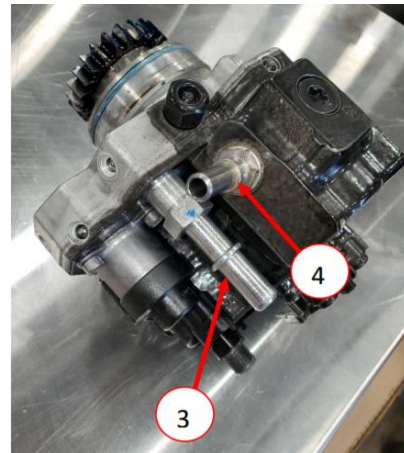

Figure 18 – HPFP Supply and Return Fittings

B. Install New Fuel Pump

1. Remove the fuel pump mounting studs in the front gear housing (these will not be reused) (Figure 19).
 - a) Take one of the fuel pump mounting nuts (5) and thread it on one of the fuel pump mounting studs with the hex head facing the front gear cover.
 - b) Take a second fuel pump mounting nut and thread it on the same mounting stud with the hex head facing away from the front gear cover.
 - c) Taking a 13mm open end wrench turn the inside nut counterclockwise to unscrew the mounting stud.
 - d) Repeat steps A-C to remove all 3 of the mounting studs.

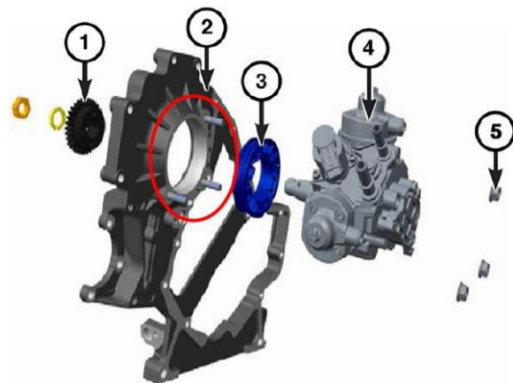

Figure 19 – Fuel Pump Mounting Studs

Service Procedure [Continued]

NOTE: The threaded holes from where the fuel pump studs were removed may need chased with a M8 x 1.25 tap to allow proper installation of the fuel pump adapter and fuel pump in the later steps.

2. Remove the bolts retaining the PCM to the PCM mounting bracket.
3. Remove the PCM mounting bracket.
4. Install the gear housing mounting adapter (Figure 20).

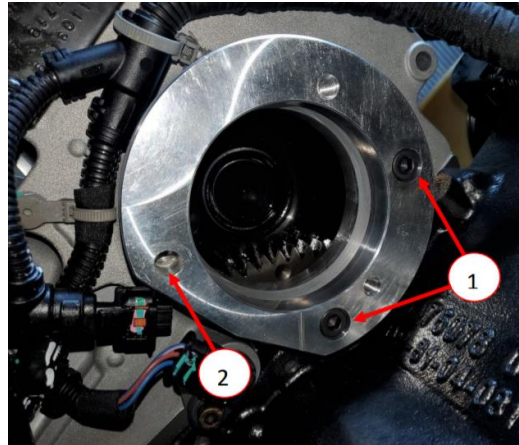

Figure 20 – Gear Housing Mounting Adapter

5. Install the adapter with the flattened side pointing down so there is clearance for the cam positioning sensor and counterbores facing the fuel pump (Figure 20).
6. Install both of the adapter bolts (PN 3420835) (1) 25mm M8's in the 2 bolts holes near the engine block (Figure 20).

NOTE: It is required to loosely install bolt (PN 3901446) in location (2) to help properly align the adapter before torquing bolts (PN 3420835) (1) (Figure 20).

7. Tighten both bolts (PN 3420835) (1) (Figure 16) to 24 N·m (18 ft. lbs.)
8. Remove the loosely installed bolt (PN 3901446) in location (2) (Figure 20). This will be used in a later step.

Service Procedure [Continued]

9. Perform the following phasing procedure anytime the injection pump has been removed and reinstalled. Rotate the injection pump shaft until the center number of the 3-digit stamped number (number 5 (1) in the example numbers 750 and 754 pictured in Figure 21) on the shaft is positioned at the 9 o'clock position (Figure 22).

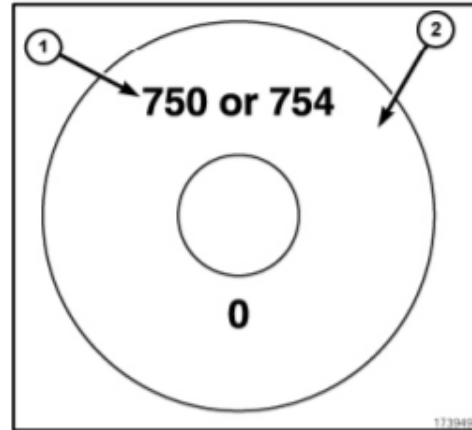

Figure 21 – HPFP Shaft End Markings (Example)

NOTE: Fuel Injection Pump used for illustration has numbers 750 or 754.

- a) Locate the end of the fuel injection pump shaft (2). Two numbers (750 or 754 and 0 in this example, actual number will vary) are stamped into the end of the shaft (Figure 21).

- b) Rotate the injection pump shaft until the number 5 (located in the center of number 750 or 754) is positioned at 9 o'clock (1) (Figure 22).

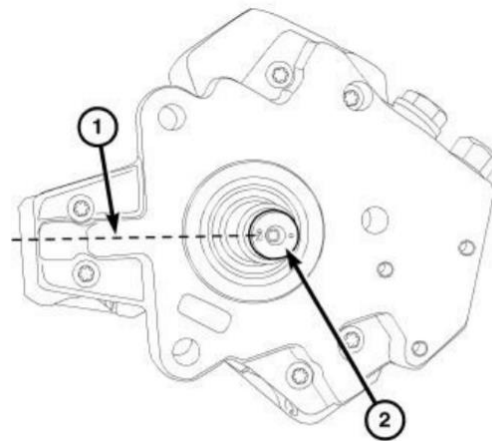
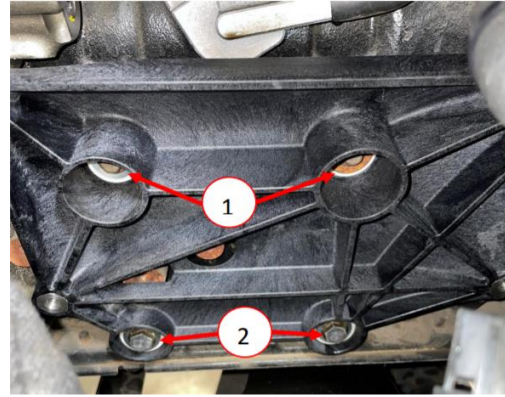

Figure 22 – HPFP Shaft Phasing

Service Procedure [Continued]

10. Using the same top bolts (1) that came out of the original PCM mounting bracket, install them in the new mounting bracket and tighten to 24 N·m (18 ft. lbs.) (Figure 23).
11. Using the provided bottom bolts (PN 5689141) (2) install them into the new mounting bracket and tighten to 24 N·m (18 ft. lbs.) (Figure 23).

**Figure 23 – New PCM Bracket**

12. Install the PCM to the new mounting bracket with the same hardware originally removed. Tighten to 24 N·m (18 ft. lbs.).
13. Position the injection pump to mounting flange on gearhousing while aligning injection pump shaft through back of injection pump gear. Be sure the number 5 is still at the 9o'clock position (1) (Figure 22).
14. With a clean rag, wipe the back side of the camshaft gear to remove residual oil. It is only necessary to wipe the portion of the camshaft gear which is accessible through the fuel pump bore in the gear housing.
15. The pump will need to be rotated to fit correctly in the space available.
16. Install the long 60 mm capscrew (PN 3901446) (1) first loosely (yellow bolt in picture below) (Figure 24).
17. Then install the two shorter 40 mm capscrews (PN 3900678) (2) (blue bolt in picture below) (Figure 24).

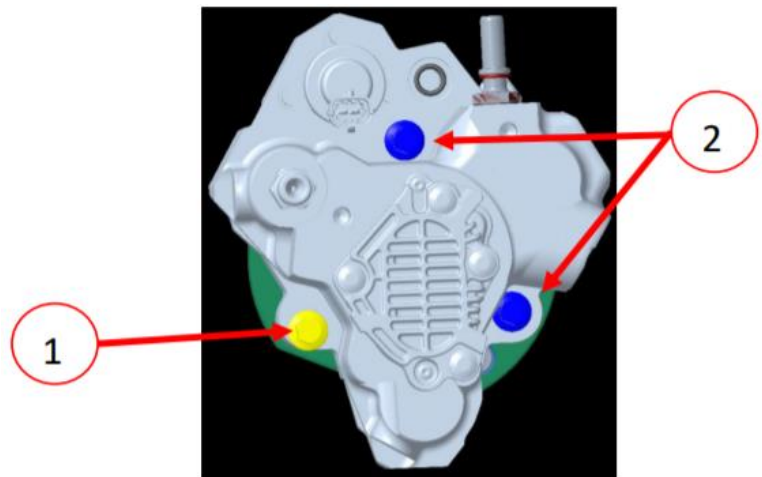
**Figure 24 – HPFP Bolts**

18. Ensure that the fuel pump is sitting flush to the adapter face.

Service Procedure [Continued]

19. Ensure that there is adequate clearance to the cam position sensor and the paint cap is removed if needed.
20. Tighten the fuel pump capscrews to 24 N·m (18 ft. lbs.).
21. Remove the old fuel line standoff (2) (Figure 25).

22. Loosely install the tail support bracket on the fuel pump using bolt (PN 3902114) (1) 30mm M8 (Figure 25).

23. Loosely install the fuel line standoff to block through the tail support (5685063) (2) (Figure 25).

24. Tighten both ends of the fuel pump tail support to 24 N·m (18 ft. lbs.).

25. The main engine harness tie down bracket (1) will be originally positioned on the harness as shown (Figure 26).



Figure 25 – HPFP Tail Support Bracket

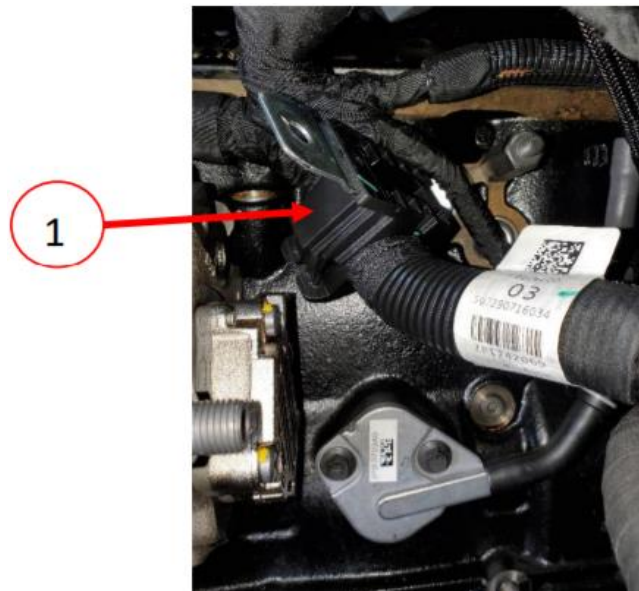

Figure 26 – Original Main Harness Tie Down Orientation

Service Procedure [Continued]

26. The tie down bracket **MUST** be loosened so it can be rotated and positioned to be secured to the leg of the fuel pump tail support to ensure there is no twisting of the main engine harness trunk as seen in Figure 25. The tie down bracket can be loosened by inserting a small flat head screwdriver into location (2) (Figure 27).



Figure 27 – New Main Harness Tie Down Orientation

Service Procedure [Continued]

27. With the tie down bracket still loose around the trunk of the main engine harness, secure the tie down bracket to the tail of the fuel pump tail support as seen below using bolt (PN 3900630) (3). Tighten bolt (PN 3900630) (3) to 10 N·m (7 ft. lbs.). Tighten the tie down bracket around the trunk of the main engine harness using the zip closure (Figure 28).



Figure 28 – Tie Down Bracket Secured

28. Check pin in the wire harness connector for corrosion, damage, or dirt intrusion. Also, check all the PCM pins for being bent. Repair as necessary.
29. Connect the engine and transmission wire harness connector to the PCM and rotate the latches closed.
30. Install the fasteners securing the engine wire harness and the transmission wiring harness to the PCM and torque them to 10 N·m (7 ft. lbs.).
31. Connect the new low-pressure return line bracket (PN 5684067) to the fuel filter support.
32. Connect the new low-pressure supply line (PN 5687735) to the fuel filter housing.
33. Connect the low-pressure supply and return lines to the fuel pump.

Service Procedure [Continued]

34. Initially finger tighten both HPFP to fuel rail supply tube union nuts at the pump and at the fuel rail. Make sure the bracket slot aligns to the standoff, slide bracket along the tube to align if slightly off (Figure 29).
35. Finger tighten the M8 nut (PN 3900589) (1) (Figure 29).
36. Tighten the union nut at the pump first, then the fuel rail to 55 N·m (41 ft. lbs.) (Figure 29).
37. Tighten the HPFP to fuel rail supply line bracket bolt (5685063) M8 115mm to proper torque 20 N·m (15 ft. lbs.).
38. Ensure there is no interference with the breather hose, pull the breather hose away from the High-Pressure line if there is contact.

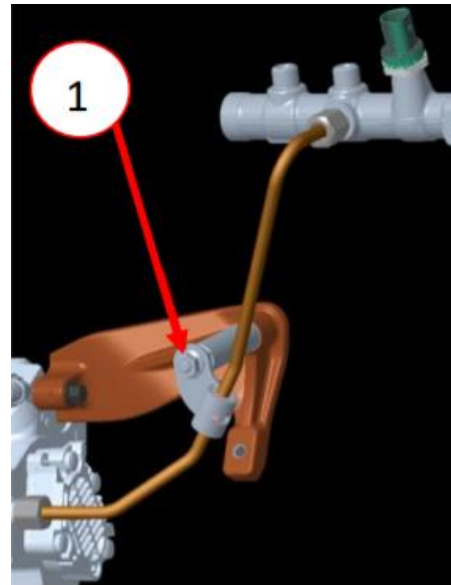

Figure 29 – HPFP to Fuel Rail Supply Line

NOTE: There will only be ONE HPFP to fuel rail supply line.

39. The second supply port in the rail will need to be blocked off using rail block off (PN 5688160) and tighten to 55 N·m (41 ft. lbs.). Do not install the rail block off with power tools.

NOTE: The rail block off nut is a one-time use part. If this nut is ever loosened or removed, it must be replaced with a new block off nut.

40. If not already installed, use the provided fuel line isolator and install on rail to injector line #4 as shown (2) (Figure 30).

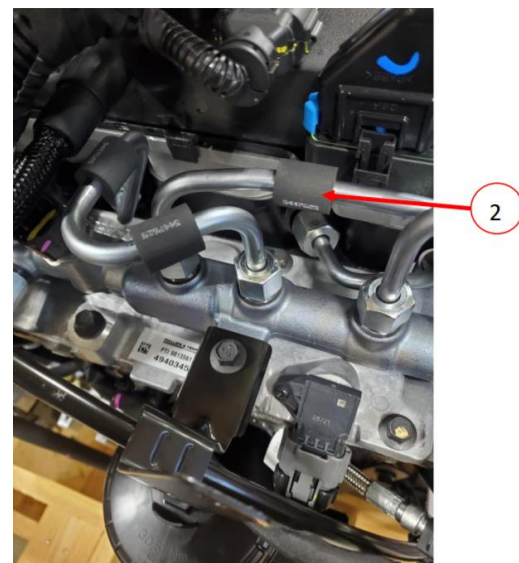

Figure 30 – Fuel Line Isolator

Service Procedure [Continued]

41. Using NEW washers, install the new pressure line (PN 5708745) (4) to the power steering pump assembly (1), using a backer wrench to stabilize the fitting tighten the bolt to 50 N·m (37 ft. lbs.) (Figure 31).
42. Reattach the standoff clip between the drain line and the harness.
43. Connect the female side of the new jumper harness to the engine wiring harness that originally attached to the FQS.
44. Connect the male side of the jumper to the FQS on the fuel pump.
45. Tie down the jumper using the provided zip-tie (PN 3062329) (1) as shown in (Figure 32).

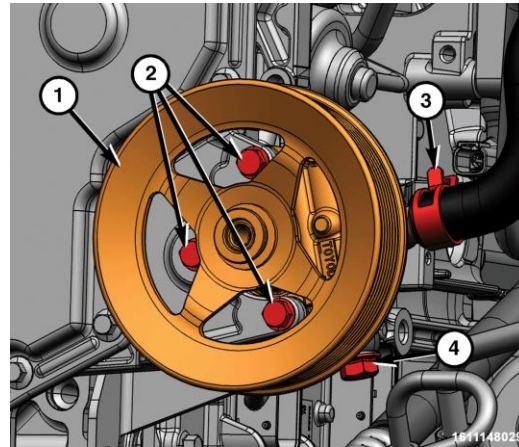

Figure 31 – Power Steering Pressure



Figure 32 – Securing Jumper Harness

Service Procedure [Continued]

46. Using the provided zip-ties (PN 3062329) attach the swivel bracket to the fuel line standoff and secure the wire harness pig tail to the swivel bracket (Figure 33).
47. Install the isolator pad for the injectors.
48. Install the harness that goes over the top of the engine and it's connectors.
49. Install the bulkhead connector at the cowl.
50. Install the left Charge Air Cooler (CAC) hose (2) to the EGR air flow control valve and tighten the clamp (3) to 11 N·m (8 ft. lbs.) (Figure 5).
51. Connect the left CAC hose (2) to the cooler and tighten the clamp (1) to Install the engine cover (2) and tighten the bolts (1) to (Figure 5).
52. Check the power steering fluid level. As measured on the side of the reservoir, the level should indicate between MAX and MIN when the fluid is at normal ambient temperature. Adjust the fluid level as necessary.
53. Install the engine cover (2) and tighten the bolts (1) to 10 N·m (89 in. lbs.) (Figure 2).
54. Install the oil dip stick (3) (Figure 2).
55. Connect the negative battery cables.
56. Install the splash shield.
57. Install the wheel and tire and torque to the proper value in Service Library.

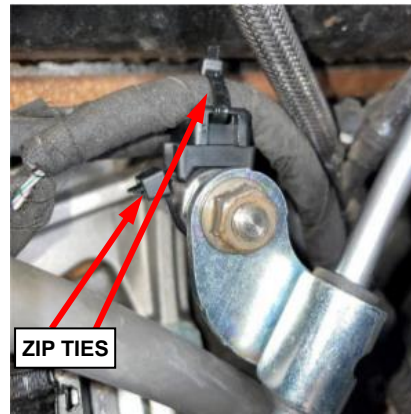

Figure 33 – Swivel Bracket to Fuel Line Standoff

Service Procedure [Continued]

NOTE: A certain amount of air becomes trapped in the fuel system when fuel system components on the supply and/or high-pressure side are serviced or replaced. Fuel system priming is accomplished using the electric fuel transfer (lift) pump.

NOTE: The fuel transfer (lift) pump is self-priming: When the ignition switch is turned to the run position (without cranking engine), the pump operates for a minimum of 30 second. In cold temperatures, the lift pump operates for up to 35 seconds. Two priming cycles (each with a duration of 30 seconds) must be performed any time the fuel system is serviced.

58. Be sure fuel is present at fuel tank.
59. Turn ignition switch to the “**RUN**” position. This will operate fuel transfer pump for a minimum of 30 seconds. Turn the ignition switch “**OFF**”.

NOTE: Install a battery charger to ensure battery voltage does not drop below 13.2 volts. Do not allow the charging voltage to climb above 13.5 volts during the flash process.

NOTE: If this flash process is interrupted/aborted, the flash should be restarted.

60. Connect the wiTECH micro pod II to the vehicle data link connector.
61. Place the ignition in the “**RUN**” position.
62. Open the wiTECH 2.0 website.
63. Enter your “**User id**” and “**Password**” and your “**Dealer Code**”, then select “**Sign In**” at the bottom of the screen. Click “**Accept**”.
64. From the “**Vehicle Selection**” screen, select the vehicle to be updated.
65. From the “**Action Items**” screen, select the “**Topology**” tab.
66. From the “**Topology**” tab, select the “**ECU**” icon.

Service Procedure [Continued]

CAUTION: The PCM MUST be programmed with the correct calibration to support the new High Pressure Fuel Injection Pump. If the correct PCM calibration with CP3.3 description is not showing in wiTECH, STOP and contact Star.

67. From the “**Flash**” tab, compare the “**Current Electronic Control Unit (ECU) Part Number**” with the “**New ECU Part Number**” listed.
- If the “**Current ECU part Number**” is the same as the “**New Part Number**”, proceed to **Step 72**.
 - If the “**Current ECU part Number**” is NOT the same as the “**New Part Number**”, continue with **Step 68**.

68. From the flash ECU agreement page, agree to terms by checking the box.

NOTE: This flash procedure requires the ignition to be cycled “OFF” then back to the “RUN” position. Follow the on-screen prompts.

69. Select “**Flash ECU**” and then follow the wiTECH screen instructions to complete the flash.
70. Select “**View All DTCs**” then “**Clear All DTCs**” and select “**Close**”.
71. Using wiTECH, perform the “**Oil Life Restore**” procedure located in the ECM “**Misc Functions**”.
72. Place the ignition in the “**OFF**” position and then remove the wiTECH micro pod II device from the vehicle.
73. Turn the ignition switch to the “**RUN**” position. This will complete an additional priming cycle and operate the fuel transfer pump for a minimum of 30 seconds.
74. Start the engine. If the engine does not start after 25 seconds, turn the ignition switch to the “**OFF**” position, and leave it off for at least 2 minutes. Repeat the previous step until the engine starts. When engine does start, allow the engine to idle for a minimum of 30 seconds. The engine may run erratically and be noisy for a few minutes. This is a normal condition.

Service Procedure [Continued]

CAUTION: Do not engage the starter motor for more than 30 seconds at a time. Allow two minutes between cranking intervals.

WARNING: The fuel injection pump supplies extremely high fuel pressure to each individual injector through the high-pressure lines. Fuel under this amount of pressure can penetrate the skin and cause personal injury. Wear safety goggles and adequate protective clothing. Do not loosen fuel fittings while engine is running.

WARNING: Engine may start while cranking starter motor.

75. Fuel system priming is now completed.

WARNING: The fluid level should be checked with engine off to prevent injury from moving components.

CAUTION: Mopar® Power Steering Fluid + 4 or Mopar® ATF+4 Automatic Transmission Fluid is to be used in the power steering system. Both Fluids have the same material standard specifications (MS-9602). No other power steering or automatic transmission fluid is to be used in the system. Damage may result to the power steering pump and system if another fluid is used. Do not overfill the system.

CAUTION: If the air is not purged from the power steering system correctly, pump failure could result.

NOTE: Be sure the vacuum tool used in the following procedure is clean and free of any fluids.

CAUTION: Failure to use a vacuum pump reservoir (1) may allow power steering fluid to be sucked into the hand vacuum pump.

Service Procedure [Continued]

76. Tightly insert P/S Cap Adapter 9688A (4) into the mouth of the reservoir (3) (Figure 34).
77. Attach Hand Vacuum Pump C-4207-A (2), or equivalent, with reservoir (1) attached to the P/S Cap Adapter 9688A (4) (Figure 34).

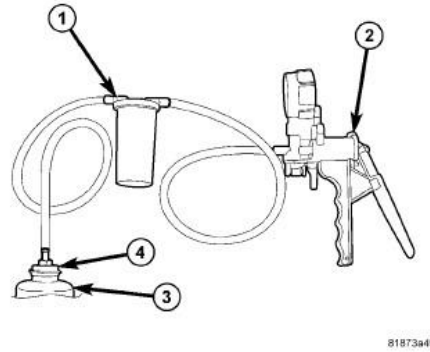
**Figure 34 – 9688A and C-4207-A**

CAUTION: Do not run the vehicle while vacuum is applied to the power steering system. Damage to the power steering pump can occur.

NOTE: When performing the following step make sure the vacuum level is maintained during the entire time period.

78. Using Hand Vacuum Pump (2), apply 68-85 kPa (20-25 in. Hg) of vacuum to the system for a minimum of three minutes.
79. Slowly release the vacuum and remove the special tools.
80. Adjust the fluid level as necessary.
81. Repeat Step 78 through Step 80 until the fluid no longer drops when vacuum is applied.
82. Start the engine and cycle the steering wheel lock-to-lock three times.

NOTE: Do not hold the steering wheel at the stops.

Service Procedure [Continued]

83. Stop the engine and check for leaks at all connections.
84. Check for any signs of air in the reservoir and check the fluid level. If air is present, repeat the procedure as necessary.
85. Clean any leaked fluid from the frame.
86. Close the hood and return the vehicle to the customer.

Service Procedure [Continued]**C. Remove, Clean and Install Fuel Tank Assembly**

NOTE: Do not attempt to flush any of the high pressure fuel components using Brakleen or similar harsh solvent cleaners. This may cause damage to any internal coatings. For an effective repair, all high pressure fuel system components should be replaced.

CAUTION: Cleanliness cannot be over emphasized when handling or replacing diesel fuel system components. This especially includes the fuel injectors, high-pressure fuel lines and fuel injection pump. Very tight tolerances are used with these parts. Dirt contamination could cause rapid part wear and possible plugging of fuel injector nozzle tip holes. This in turn could lead to possible engine misfire. Always wash/clean any fuel system component thoroughly before disassembly and then air dry. Cap or cover any open part after disassembly. Before assembly, examine each part for dirt, grease or other contaminants and clean if necessary.

NOTE: Be sure to cap or cover any part of the fuel system after disassembly using Protection Kit, Caps & Covers 2065600140.

NOTE: Follow the Diesel Fuel System Cleaning Procedure under 14 - Fuel System / Fuel Delivery, Diesel / Standard Procedure.

WARNING: The fuel system may be under a constant pressure (even with the engine off). Before servicing the fuel pump module, the fuel system pressure must be released.

NOTE: Two different procedures may be used to drain fuel tank: using a diagnostic scan tool to activate the fuel pump relay and drain the fuel tank or remove the fuel pump. Due to a one-way check valve installed into the fuel fill opening fitting at the tank, the tank cannot be drained conventionally at the fill cap.

Service Procedure [Continued]

NOTE: For dual fuel tank applications. Cleaning of the secondary tank and replacement of the fuel transfer pump is unnecessary in the event of a fuel injection pump failure unless the fuel system has been contaminated from an outside source (e.g. rust, dirt, DEF Gasoline contamination). All fuel from a fuel injection pump failure is returned to the primary tank only.

1. Disconnect the fuel supply line quick-connect fitting at the engine fuel filter.
2. Install the appropriate Fuel Line Adapters/Fitting from the Decay Tool, Fuel 8978A. Route the opposite end of this hose to a diesel fuel draining station.
3. Using a scan tool, activate the fuel pump and drain the tank until empty.
4. Raise and support the vehicle.
5. If equipped, remove the fuel tank skid plate. See Service Library 13 - Frame and Bumpers / Under Body Protection / PLATE, Skid, Fuel Tank / Removal and Installation.
6. Remove the rear drive shaft from the rear axle and properly support it to prevent damage. See Service Library 03 - Differential and Driveline / Driveshaft / SHAFT, Drive, Rear / Removal and Installation.
7. Using a suitable hydraulic jack with a fuel tank adapter, support the fuel tank.
8. Remove the two nuts (1) and both fuel tank support straps (2) (Figure 35).
9. Partially lower the fuel tank to gain access to the fuel lines.

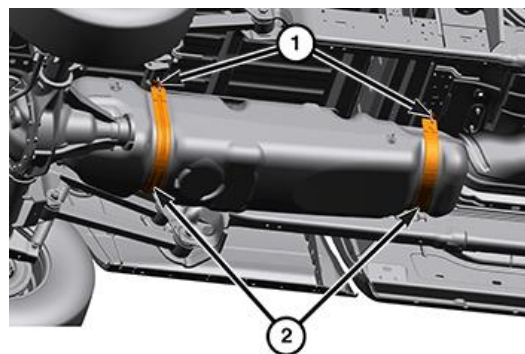

1401148454

Figure 35 – Fuel Tank Straps (Sales Code NFT Shown)

Service Procedure [Continued]

10. Loosen the clamp (3) and disconnect the fuel filler hose (Figure 36).
11. Loosen the clamp (1) and disconnect the fuel vent hose (Figure 36).
12. Disconnect the fresh air vent hose (2) (Figure 36).

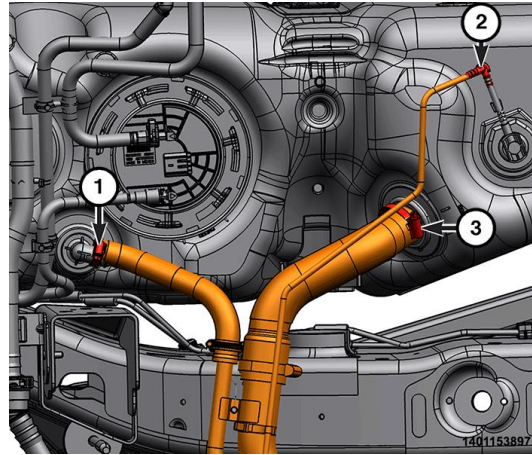

Figure 36 – Fuel Tank Connections (Sales Code NFT Shown)

13. Disconnect the fuel pump module wire harness connector (2) (Figure 37).
14. Disconnect the fuel supply (1) and return line (3) quick-connect fitting at the fuel pump module (Figure 37).

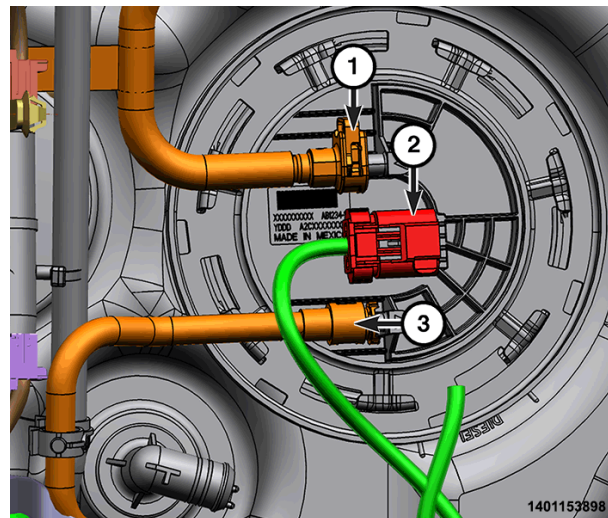

Figure 37 – Fuel Pump Module Connections (Sales Code NFT Shown)

Service Procedure [Continued]

15. Disconnect the DEF pipes from the clip behind the tank shield (Figure 38).
16. Lower the fuel tank and remove from hydraulic jack.



Figure 38 – DEF Pipe Clip (Sales Code NFT Shown)

NOTE: Prior to removing the fuel pump module, use compressed air to remove any accumulated dirt and debris from around fuel tank opening.

CAUTION: An indexing arrow is located on top of the main fuel pump module to clock its position into the fuel tank, note its location for reassembly.

17. Position the lock ring remover/installer SAE Fuel Pump Lock Ring Wrench 9340 in the notches on the outside edge of the lock ring.
18. Install a 1/2 inch drive breaker bar in the top of the lock ring remover/installer.
19. Rotate the breaker bar counterclockwise and remove the lock ring.
20. Remove and discard the fuel pump module from the fuel tank.
21. Remove and discard the rubber O-ring seal.
22. Using appropriate storage and/or disposal methods, in accordance with your local regulations drain, and dispose of all the contaminated fuel from the fuel tank.
23. Thoroughly clean, and flush the fuel tank using fresh, clean, diesel fuel.

Service Procedure [Continued]

CAUTION: An indexing arrow is located on top of the main fuel pump module to clock its position into the fuel tank. The fuel pump module must be installed in the same position as removed.

24. Using a NEW rubber O-ring seal, position the NEW fuel pump module in the fuel tank opening. Be careful not to bend float arm during removal.
25. Position the lock ring over top of the fuel pump module.
26. Rotate the fuel pump module until the embossed alignment arrow points to the center alignment mark or the same position as noted during removal. This step must be performed to prevent the float from contacting the side of the fuel tank.
27. Install the lock ring remover/installer in the notches on the outside edge of the lock ring.
28. Install a 1/2 inch drive breaker bar in the top of the lock ring remover/installer.
29. Rotate the breaker bar clockwise until all seven notches of the lock ring have engaged.
30. Secure the fuel tank on a suitable hydraulic jack with a fuel tank adapter.
31. Partially raise the fuel tank allowing access for fuel line connection.
32. Reinstall the fuel tank, leaving the chassis fuel return line disconnected at the tank.
33. Connect the DEF pipes to the clip behind the tank shield (Figure 38).
34. Connect the fuel supply (1) and return (3) line quick connect fitting to the fuel pump module (Figure 37).
35. Connect the fuel pump module wire harness connector (2) (Figure 37).
36. Connect the fresh air vent hose (2) (Figure 36).

Service Procedure [Continued]

37. Connect the fuel vent hose and securely tighten the clamp (1) (Figure 36).
38. Connect the fuel filler hose and securely tighten the clamp (3) (Figure 36).
39. Fill the tank with 21 gallons of fresh fuel.
40. Remove the chassis mounted fuel filter element.
41. Lower the vehicle and connect the negative battery cable(s) and IBS. Raise the vehicle.
42. Place an appropriate catch basin under the fuel filter housing to capture all fuel expelled during the next steps.
43. Turn the ignition to run and allow the in-tank fuel pump to run a complete cycle (approx. 15 seconds). Capture all the fuel expelled from the filter housing.
44. Using wiTECH, navigate to the PCM "Actuators" tab, and perform the Lift Pump Relay routine to activate the in-tank fuel pump. This routine will run the pump for 20 seconds. Capture all fuel expelled from the fuel filter housing.
45. Repeat Step 44, 2 additional times.
46. Install a NEW chassis mounted fuel filter element.
47. Place an appropriate catch basin under the engine mounted fuel filter housing to capture all fuel expelled during the next steps.
48. Open the drain valve and drain the engine mounted fuel filter housing.
49. Remove the filter element. Leave the drain valve open at this time.
50. Thoroughly clean the filter housing bowl of all debris.
51. Using wiTECH, perform the Lift Pump Relay routine to activate the in-tank fuel pump. The fuel filter housing will begin to fill. If necessary, stop the routine before the housing begins to overflow.

Service Procedure [Continued]

52. Allow the housing to fully drain and clean out any additional debris that is present.
53. Repeat steps 51 and 52, 2 additional times.
54. Install a NEW fuel filter element and tighten the cap to 31 N·m (23 ft. lbs.).
55. Close the fuel filter housing drain valve.
56. Disconnect the fuel supply hose from the high pressure fuel injection pump.
57. Connect a suitable hose to the fuel supply hose, and route it into a suitable container.
58. Using wiTECH, perform the Lift Pump Relay routine to activate the in-tank fuel pump for 1 complete cycle to flush any contaminants out of the supply line.

NOTE: Be sure to reattach the fuel supply hose previously disconnected.

59. Replace the high-pressure fuel rail.
60. Replace all 6 fuel injectors, and injector connector tubes.
61. Install NEW high pressure fuel rail to fuel injector fuel tube.
62. Install NEW high pressure fuel injection pump to rail supply tubes.
63. Attach a suitable hose to the fuel return line fitting left disconnected at the tank.
64. Route the hose into a suitable container.
65. Start the engine and allow it to run until approximately 2-3 gallons of fuel has been captured from the fuel return line. This ensures that any debris in any of the remaining fuel return system components, including the cylinder head, has been fully expelled from the system.

Service Procedure [Continued]

66. Reconnect the chassis fuel return line at the tank.
67. Raise the fuel tank until snug to the body. Install the fuel tank straps (2) and tighten the nuts (1) (Figure 35).
 - Fuel Tank Mounting Straps Nuts (Mid-Ship) 50 N·m (37 ft. lbs.)
 - Fuel Tank Mounting Bolts (Rear) 61 N·m (45 ft. lbs.)
68. Remove the hydraulic jack.
69. Install the rear drive shaft. See Service Library 03 - Differential and Driveline / Driveshaft / SHAFT, Drive, Rear / Removal and Installation.
70. If equipped, install the fuel tank skid plate. See Service Library 13 - Frame and Bumpers / Under Body Protection / PLATE, Skid, Fuel Tank / Removal and Installation.
71. Top off the fuel tank with fresh fuel if necessary and verify the repair.

Complete Proof of Correction Form for California Residents

This recall is subject to the **State of California Registration Renewal/Emissions Recall Enforcement Program**. Complete a Vehicle Emission Recall Proof of Correction Form (**Form No. 81-016-1053**) and **supply it to vehicle owners residing in the state of California** for proof that this recall has been performed when they renew the vehicle registration.

Process Steps to obtain the California Proof of Correction form:

- a. Access the “**DealerCONNECT**” website.
- b. Select the “**Service**” tab.
- c. Under the “**Publications**” heading, select the “**ePublishing**” link.
- d. Sign in using your **Dealer Code** and **Password**.
- e. Select the “**Proof of Correction form**”.

Completion Reporting and Reimbursement

Claims for vehicles that have been serviced must be submitted on the DealerCONNECT Claim Entry Screen located on the Service tab. Claims paid will be used by FCA to record recall service completions and provide dealer payments.

Use the following labor operation numbers and time allowances:

	Labor Operation Number	Time Allowance
Replace HPFP and Reprogram PCM	14-Y7-81-82	3.5 hours
Replace HPFP, Fuel Lines, Fuel Injectors Lift Pump, Clean Fuel Tank, Fuel Rail, Fuel Filters Flush Fuel System and Reprogram PCM	14-Y7-81-83	9.6 hours

Related Labor Operations

Fuel Allowance for Safety Recall Y78	95-14-01-56	██████████
--------------------------------------	-------------	------------

Related Labor Operations

Dual Alternator Equipped	14-Y7-81-61	0.5 hours
Adaptive Steering System Equipped (Sales Code SJE)	14-Y7-81-62	0.6 hours
Drain Fuel (52 Gallon Tank Only)	14-Y7-81-63	0.7 hours
Drain Fuel (50 Gallon Tank Only)	14-Y7-81-64	0.6 hours
Drain Fuel (32, 31 or 28 Gallon Tanks Only)	14-Y7-81-65	0.4 hours
Drain Fuel (22 Gallon Tank Only)	14-Y7-81-66	0.3 hours
Disposal of Contaminated Diesel Fuel (*receipt required)	95-14-04-50	██████████*

Completion Reporting and Reimbursement [Continued]

Add the cost of the recall parts package plus applicable dealer allowance to your claim.

In addition, enter “MATL” in the Part Number section of your claim with the applicable Material Allowance where appropriate.

NOTE: See the Warranty Administration Manual, Recall Claim Processing Section, for complete recall claim processing instructions.

Dealer Notification

To view this notification on DealerCONNECT, select “Global Recall System” on the Service tab, then click on the description of this notification.

Owner Notification and Service Scheduling

All involved vehicle owners known to FCA are being notified of the service requirement by first class mail. They are requested to schedule appointments for this service with their dealers. A generic copy of the owner letter is attached.

Vehicle Lists, Global Recall System, VIP and Dealer Follow Up

All involved vehicles have been entered into the DealerCONNECT Global Recall System (GRS) and Vehicle Information Plus (VIP) for dealer inquiry as needed.

GRS provides involved dealers with an updated VIN list of their incomplete vehicles. The owner's name, address and phone number are listed if known. Completed vehicles are removed from GRS within several days of repair claim submission.

To use this system, click on the “**Service**” tab and then click on “**Global Recall System.**” Your dealer's VIN list for each recall displayed can be sorted by: those vehicles that were unsold at recall launch, those with a phone number, city, zip code, or VIN sequence.

Dealers must perform this repair on all unsold vehicles before retail delivery. Dealers should also use the VIN list to follow up with all owners to schedule appointments for this repair.

Recall VIN lists may contain confidential, restricted owner name and address information that was obtained from the Department of Motor Vehicles of various states. Use of this information is permitted for this recall only and is strictly prohibited from all other use.

Additional Information

If you have any questions or need assistance in completing this action, please contact your Service and Parts District Manager.

Customer Services / Field Operations
FCA US LLC

This notice applies to your vehicle.

[Model Year and Model]

VIN XXXXXXXXXXXXXXXXXXXX

Y78/NHTSA 21V-880

LOGO

VEHICLE PICTURE

YOUR SCHEDULING OPTIONS

- 1. RECOMMENDED OPTION**
Call your authorized Chrysler / Dodge / Jeep® / RAM Dealership
- 2. Call the FCA Recall Assistance Center at 1-800-853-1403.** An agent can confirm part availability and help schedule an appointment
- 3. Visit recalls.mopar.com, scan the QR code below, or download the Mopar Owner's Companion App.**

QR Code

Get access to recall notifications, locate your nearest dealer, and more through this website or Mopar Owner's Companion App. You will be asked to provide your Vehicle Identification Number (VIN) to protect and verify your identity. The last eight characters of your VIN are provided above.

DEALERSHIP INSTRUCTIONS

Please reference Safety Recall Y78.

IMPORTANT SAFETY RECALL

High Pressure Fuel Pump

Dear [Name],

This notice is sent to you in accordance with the National Traffic and Motor Vehicle Safety Act.

FCA US has decided that a defect, which relates to motor vehicle safety, exists in certain [2019 through 2020 Model Year (D2) Ram 3500 Pickup, (DD) Ram 3500 Cab Chassis, (DJ) Ram 2500 Pickup and (DP) Ram 4500/5500 Cab Chassis] vehicles.

It is extremely important to take steps now to repair your vehicle to ensure the safety of you and your passengers.

WHY DOES MY VEHICLE NEED REPAIRS?

The high pressure fuel pump (HPFP) on your vehicle ^[1] may fail prematurely. A high pressure fuel pump failure may introduce internally failed component debris into the fuel system potentially causing fuel starvation. Vehicle occupants may notice a Malfunction Indicator Lamp illuminating, a fuel leak, abnormal engine noise, or a change in drive quality. **Fuel starvation may result in an unexpected loss of motive power, which can increase the risk of a vehicle crash without prior warning.**

HOW DO I RESOLVE THIS IMPORTANT SAFETY ISSUE?

FCA US will repair your vehicle ^[2] free of charge (parts and labor). To do this, your dealer will replace the HPFP, update the Powertrain Control Module (PCM) software, and inspect and, if necessary, replace additional fuel system components. The estimated repair time is between 4 to 12 hours depending on vehicle configuration. In addition, your dealer will require your vehicle for proper check-in, preparation, and check-out during your visit, which may require more time. Your time is important to us, so we recommend that you schedule a service appointment to minimize your inconvenience. Please bring this letter with you to your dealership.

**TO SCHEDULE YOUR FREE REPAIR,
CALL YOUR CHRYSLER, DODGE, JEEP OR RAM DEALER TODAY**

CALIFORNIA RESIDENTS

The State of California requires the completion of emission recall repairs prior to vehicle registration renewal. Your dealer will provide you with a Vehicle Emission Recall Proof of Correction Form after the Safety Recall service is performed. Be sure to save this form since the California Department of Motor Vehicles may require that you supply it as proof that the Safety Recall has been performed.

In order to ensure your full protection under the emissions warranty provisions, it is recommended that you have your (vehicle or engine) serviced as soon as possible. Failure to do so could be determined as lack of proper maintenance of your (vehicle or engine).

WHAT IF I ALREADY PAID TO HAVE THIS REPAIR COMPLETED?

If you have already experienced this specific condition and have paid to have it repaired, you may visit www.fcarecallreimbursement.com to submit your reimbursement request online. ^[3] Once we receive and verify the required documents, reimbursement will be sent to you within 60 days. If you have had previous repairs performed and/or already received reimbursement, you may still need to have the recall repair performed.

We apologize for any inconvenience, but are sincerely concerned about your safety. Thank you for your attention to this important matter.

Customer Assistance/Field Operations
FCA US LLC



Mr. Mrs. Customer
1234 Main Street
Hometown, MI 48371

[1] If you no longer own this vehicle, please help us update our records. Call the FCA Recall Assistance Center at 1-800-853-1403 to update your information.

[2] If your dealer fails or is unable to remedy this defect without charge and within a reasonable time, you may submit a written complaint to the Administrator, National Highway Traffic Safety Administration, 1200 New Jersey Ave., S.E., Washington, DC 20590, or you can call the toll-free Vehicle Safety Hotline at 1-888-327-4236 (TTY 1-800-424-9153), or go to safercar.gov.

[3] You can also mail in your original receipts and proof of payment to the following address for reimbursement consideration: FCA Customer Assistance, P.O. Box 21-8004, Auburn Hills, MI 48321-8007, Attention: Recall Reimbursement.

Note to lessors receiving this recall notice: Federal regulation requires that you forward this recall notice to the lessee within 10 days.