

Wiring Information for Standard **Single Phase Electric Motors**

Before installing and operating this Motor please read the following instructions

EMG Motors series – **EMBP**

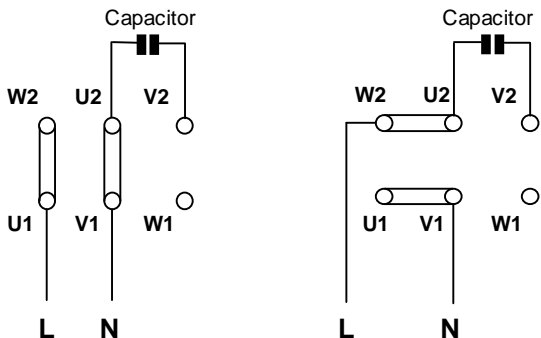

Clockwise Rotation

Anti-Clockwise Rotation

Rotation – Motors are supplied as standard wired for clockwise rotation (facing shaft end).

To reverse rotation see diagram above

Do not alter motor winding connections or move capacitor wires

EMG Motors series - **EMB**

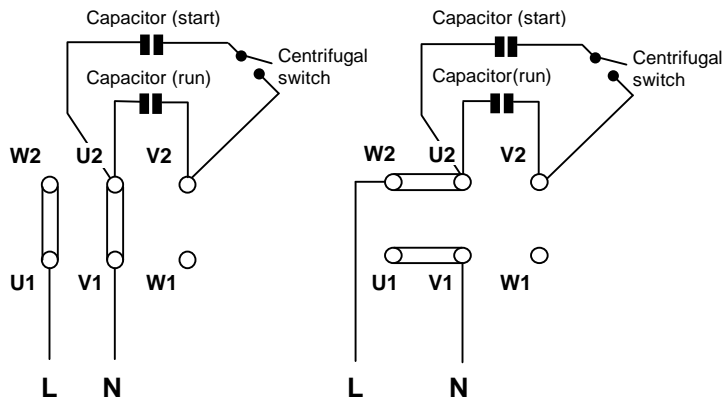

Clockwise Rotation

Anti-Clockwise Rotation

Rotation – Motors are supplied as standard wired for clockwise rotation (facing shaft end).

To reverse rotation see diagram above

Do not alter motor winding connections or move capacitor wires

FFD Motors series – **FDET (FDEB)**

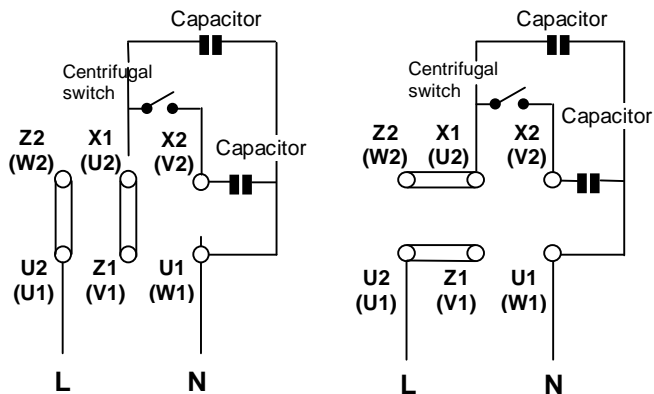

Clockwise Rotation

Anti-Clockwise Rotation

FDEB series terminal block details shown in brackets

Rotation – Motors are supplied as standard wired for clockwise rotation (facing shaft end).

To reverse rotation see diagram above

Do not alter motor winding connections or move capacitor wires

FFD Motors series – **NPEKm, NPEKg, NPEKh**

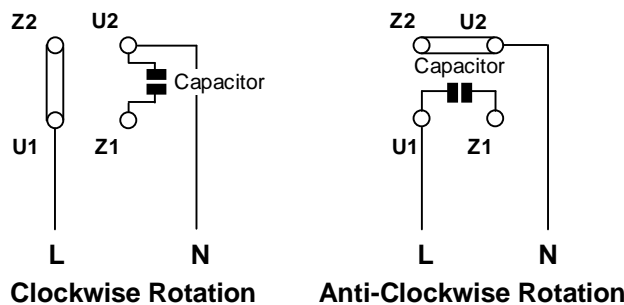

Clockwise Rotation

Anti-Clockwise Rotation

Rotation – Motors are supplied as standard wired for clockwise rotation (facing shaft end).

To reverse rotation interchange link and Capacitor as shown above.

Move link U1 - Z1 to U2 - Z2
 Move capacitor lead from U2 – U1

Do not move winding connections

Important NOTE – Please contact our sales office before using motors with invertors or speed controllers.

All Single phase motors supplied are voltage and frequency specific and unless otherwise stated can only be used on the voltage and frequency stated on the motor nameplate.

Applications that require frequent starting or long periods of off load running can cause premature failure of the motor.

Maintenance

Always **isolate** the supply to the Motor before carrying out any maintenance. Motors supplied with pre-greased sealed for life bearings should require no maintenance other than ensuring that the fan cowl and cooling fins of the motor are clear of dust dirt and other obstructions.

Spares

When ordering spares please state the KP number for the motor which is shown on an Orange sticker in the terminal box. If this is not available then please take all information from the rating plate before contacting our sales office, including mounting information (does the motor have feet if a flange is fitted what type B5, B14 etc.). If single phase is it Capacitor Start Capacitor Run or Permanent Capacitor type.

Guarantee

All motors supplied carry a 12-month guarantee valid from date of first operation or 18-months from date of despatch whichever expires soonest. In the unlikely event of a failure occurring during this period the buyer or user should not undertake any repairs by themselves or a third party without written consent from our office. Failure to do this will result in the guarantee being invalid.

NOTE – Any goods that are to be returned must be accompanied by an RMA (Returned Motor Authorisation). Goods returned without an RMA will be rejected by our goods inwards. If Motors are to be returned contact our sales office for the required forms.

Any goods returned and found to be of merchantable quality and free of proposed defects then the buyer shall bear a restocking or redelivery charge of 25%.

Any performance data or information pertaining to a three phase motor must not be used as a guide for the equivalent sized Single Phase motor, e.g. Full load current, no load current, heating effect etc.

General information regarding single phase motors

Single Phase electric motors have a capacitor connected in series with the run winding, therefore the motor is always drawing a constant current irrespective of mechanical load. When the motor is not loaded (driving) this 'residual' current is dissipated in the form of heat. Single Phase electric motors therefore should always be used at or near 'full load' so that the energy is converted into mechanical 'work' and not into heat.

Due to the 'transformer' effect brought about by the start and run windings being in parallel the voltage appearing across the Run Capacitor can be typically 350-480 volts dependant on the actual motor size. This will always be at its highest when the motor is off load. With Run Capacitors generally being 450/470 volts rated it is therefore another reason not to run the motor at no load for a long period otherwise capacitor life will be reduced and/or cause premature failure.

Kenworth Electric Motors

A Division of Kenworth Products Ltd

U.K Distributors for FFD, E.M.G, Bartec-Varnost and Electromotor
Unit 2, Crossley Mills, New Mill Road, Honley, Holmfirth, HD9 6QB, England

Tel: +44(0)1484 660222

Fax: +44(0)1484 660333

Installation/Operation/Maintenance Instructions for standard SINGLE PHASE electric motors

Warning – All work must be carried out by appropriately qualified personnel. Always use any lifting facilities provided. The manufacturer will not accept any warranty claim arising from incorrect mounting, connection or operation.

Delivery

On receipt of the Motor please inspect the goods for any damage and report to the carrier immediately. Note that any goods signed for, but found to be damaged, can not be claimed for under warranty.

Storage

The Motors should be stored indoors in a dry, vibration and dust free environment within the ambient temperature range of -20°C to +75°C and humidity of no more than 90%. If anti-condensation heaters are fitted they should where possible be energised.

Installation and connection

Qualified Electro-mechanical personnel shall install the motor. Ensure that the installation is in compliance with all rating plate data and any warning labels. If the Motor has been stored for any length of time the insulation resistance should be tested using an Ohmmeter and be a least 10 MΩ. In the event that the insulation resistance is lower than this then the Motor should be subjected to a drying process. Prior to installation the information on the rating plate of the Motor should be carefully checked to ensure that it conforms to the electrical supply and control gear to be used. Standard Motors are designed to operate in an ambient temperature of -20°C to + 40°C, a relative humidity of 100% and an altitude of up to 1000m. If the motor is to be used outside these parameters then please refer to our works before installation. Motors can be manufactured to meet non-standard requirements. Care should be taken when fitting pulleys, couplings etc. as excessive loading can result in permanent damage to the motor bearings. It is also important to align pulleys and couplings correctly as failure to do so can result in excessive vibration and ultimately bearing collapse or shaft breakage. The correct belt tension is little more than is necessary to transmit the load.

Ensure that the connection cables between starting equipment and the Motor are adequately rated for both full load current and starting current so that excessive voltage drop does not occur. **Appropriate overload and short circuit protection must be fitted and correctly adjusted for all motors.** Fuses should not be used as overload protection. Bond all equipment to earth in accordance with legislation. Electrical compliance should be in accordance with BS 7671.

When mounting a Motor of the form B3 (with feet) particular care must be taken to ensure that the surface to which the Motor is mounted is flat. Failure to do this can result in the casting twisting and the feet cracking or breaking when the fastenings are secured.

With B14 mounting (flange or face) the length of the fastenings must be checked before fixing. Using fastenings that are too long can result in damage to the winding of the Motor as fastening holes in the B14 flange continue through the flange and into the Motor.

In addition to the main winding and earth terminals the terminal box may also have connections for thermistors, anti-condensation heaters or bimetallic switches.

Warning – If Anti-condensation heaters are fitted a supply may be connected to the motor even when being stored ready for use.