



Toyota
U660-E

INDEX

Introduction.....	2
Component Application Chart.....	4
Sprag Rotation.....	5
Pressure Testing.....	6
Fluid Specification.....	8
Transmission Range Sensor.....	10
TCM Location.....	13
Valve Body To Case Attaching Bolt Identification.....	14
Internal Wiring Harness.....	15
Solenoid Identification And Location.....	17
Solenoid Operation.....	18
Failsafe Strategies.....	20
Fluid Pressure Switch.....	22
Internal Speed Sensors.....	24
ECM/PCM Connector Views.....	26
Wiring Diagram.....	27
Valve Body.....	28
Case Passage Identification.....	34
Diagnostic Trouble Codes.....	35
Valve Body Mapping Text.....	36

VALVE BODY MAPPING:

Valve Body Mapping Oil Circuit Diagram

OIL CIRCUIT DIAGRAMS:

Park	Drive 3rd Gear
Reverse	Drive 4th Gear
Reverse Inhibit	Drive 5th Gear
Neutral	Drive 5-4 Kickdown
Drive 1st Gear	Drive 6th Gear TCC OFF
Drive 2nd Gear	Drive 6th Gear TCC ON
Drive 2nd Flex TCC	Manual 1st

AUTOMATIC TRANSMISSION SERVICE GROUP
18635 S.W. 107 AVENUE
CUTLER BAY, FLORIDA 33157
(305) 670-4161



*1st Printing
November 2011*

Introduction

The U660-E transmission a front wheel drive 6 speed fully automatic electronically controlled transmission used in Toyota and Lexus vehicles worldwide. The TCM is mounted on the transmission facing the front of the vehicle and plugs directly in to the transmission case connector.

This manual provides a component and solenoid application chart, sprag rotation, an OBD2 Code list, detailed information on the valve body, valve body mapping for circuit tracing as well as a complete set of oil schematics.

No part of any ATSG publication may be reproduced, stored in any retrieval system or transmitted in any form or by any means, including but not limited to electronic, mechanical, photocopying, recording or otherwise, without *written* permission of Automatic Transmission Service Group. This includes all text illustrations, tables and charts.

The information and part numbers contained in this booklet have been carefully compiled from industry sources known for their reliability, but ATSG does not guarantee its accuracy.

Copyright © ATSG 2012

WAYNE COLONNA
TECHNICAL CONSULTANT

PETER LUBAN
TECHNICAL CONSULTANT

GERALD CAMPBELL
TECHNICAL CONSULTANT

GREG CATANZARO
TECHNICAL CONSULTANT

JON GLATSTEIN
TECHNICAL CONSULTANT

JIM DIAL
TECHNICAL CONSULTANT

DALE ENGLAND
TECHNICAL CONSULTANT

ED KRUSE
TECHNICAL CONSULTANT

GREGORY LIPNICK
TECHNICAL CONSULTANT

DAVID CHALKER
TECHNICAL CONSULTANT

AUTOMATIC TRANSMISSION SERVICE GROUP
18635 SW 107TH AVENUE
CUTLER BAY, FLORIDA 33157
(305) 670-4161

TOYOTA U660E

Model Application

Taken from the 2011 Automatic Transmission Guide Global Edition by **TRANS^{tec}**®:

Toyota

Alphard	2008-2011
Aurion	2006-2011
Avalon	2008-2011
Avensis	2008-2011
Blade	2008-2011
Camry	2006-2011
Estima	2006-2011
Highlander	2009-2011
Mark X Z10	2007-2011
RAV 4	2008-2011
Sienna	2009-2011
Vanguard	2011
Venza	2008-2011
Verso	2009-2011

Lexus

ES350	2006-2011
RX350	2008-2011

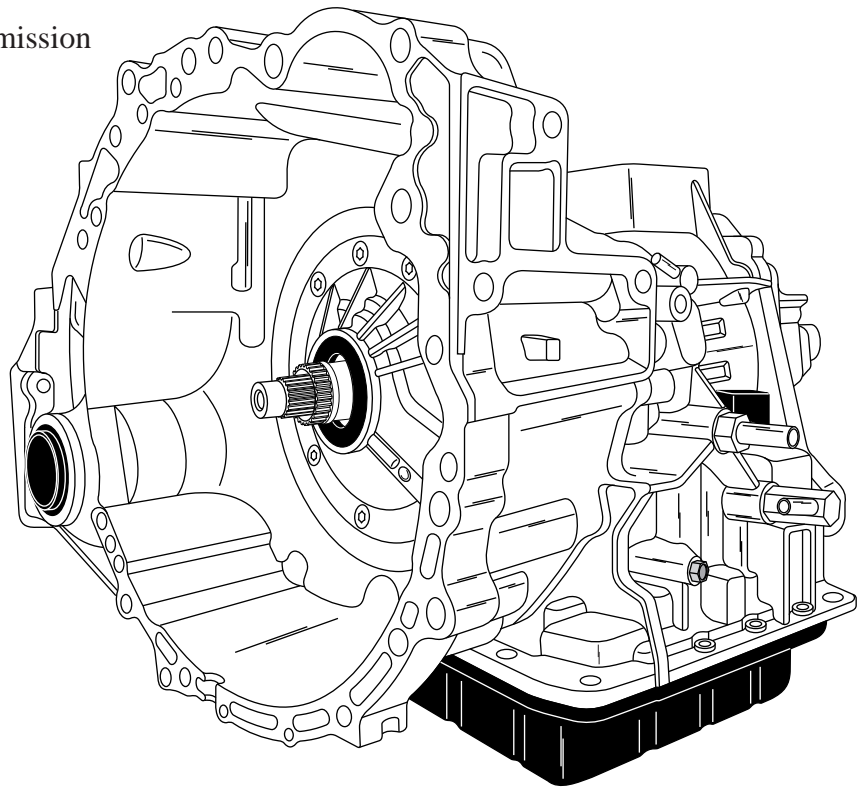

Specifications

Gear Ratios for a 2007 Camry:

1st.....	3.300
2nd.....	1.900
3rd.....	1.420
4th.....	1.000
5th.....	0.713
6th.....	0.608
Reverse.....	4.148
Differential	
Gear Ratio.....	3.685
(Counter gear included)	

Fluid Capacity - Liters (US qts, Imp. qts)

6.57 (6.94, 5.78) Includes Differential

Fluid Type: Toyota Genuine ATF WS

Weight: 94.4kg - 208.1lbs - Includes fluid filled to maximum level

Two Driving Clutches : C1 & C2
 Three Brake Clutches : B1, B2 & B3
 One 1-way Clutch: F1

1 Ravigneaux Planetary Gear Set
 Front Sun Gear: 30 teeth
 Rear Sun Gear: 27 teeth
 Long Pinion Gear: 20 teeth
 Short Pinion Gear: 22 teeth
 Ring Gear: 69 teeth

U/D Planetary Gear Set
 Sun Gear: 66 teeth
 Pinion Gear: 21 teeth
 Ring Gear: 110 teeth

Counter Gear
 Drive gear: 44 teeth
 Driven Gear: 47 teeth

Figure 1

**TOYOTA U660E
COMPONENT APPLICATION CHART**

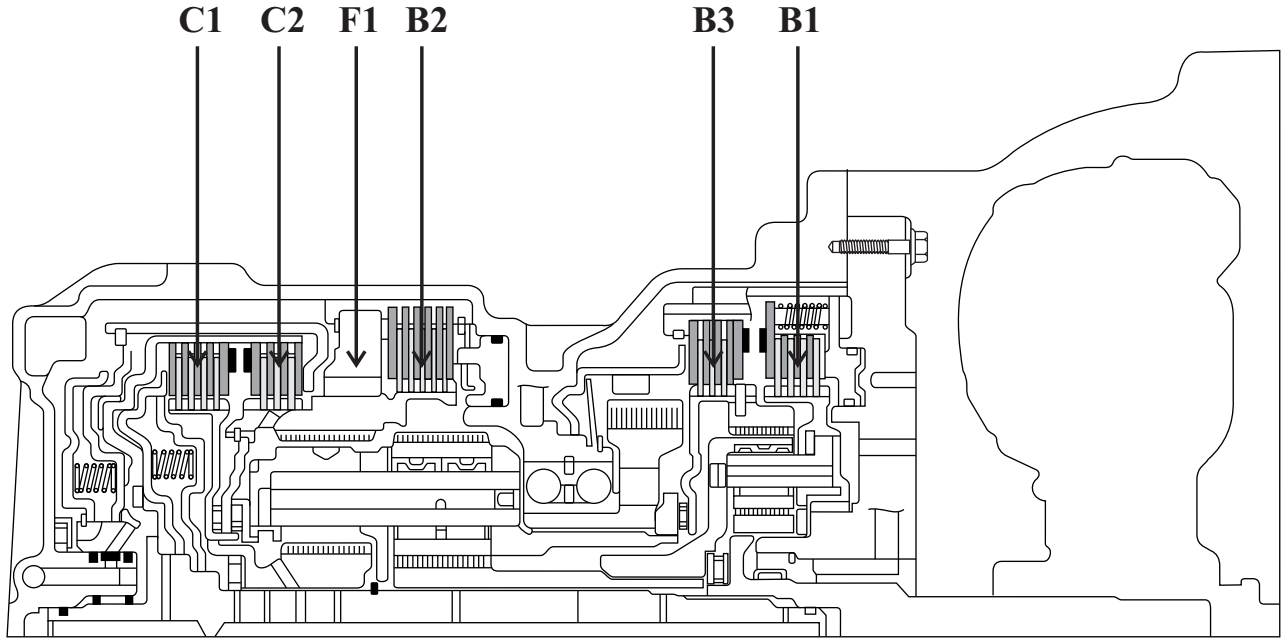

Shift Lever	Gear	C1	C2	B1	B2	B3	F1
P	Park						
R	Reverse				X	X*	
N	Neutral						
D, S6	1st	X					X
	2nd	X		X			
	3rd	X				X	
	4th	X	X				
	5th		X			X	
	6th		X	X			
S1	1st/Manual	X		X			X

** - For safety reasons, the computer can inhibit a reverse engagement by energizing the SL solenoid which will release the B3 clutch.*

**TOYOTA U660E
SPRAG ROTATION**

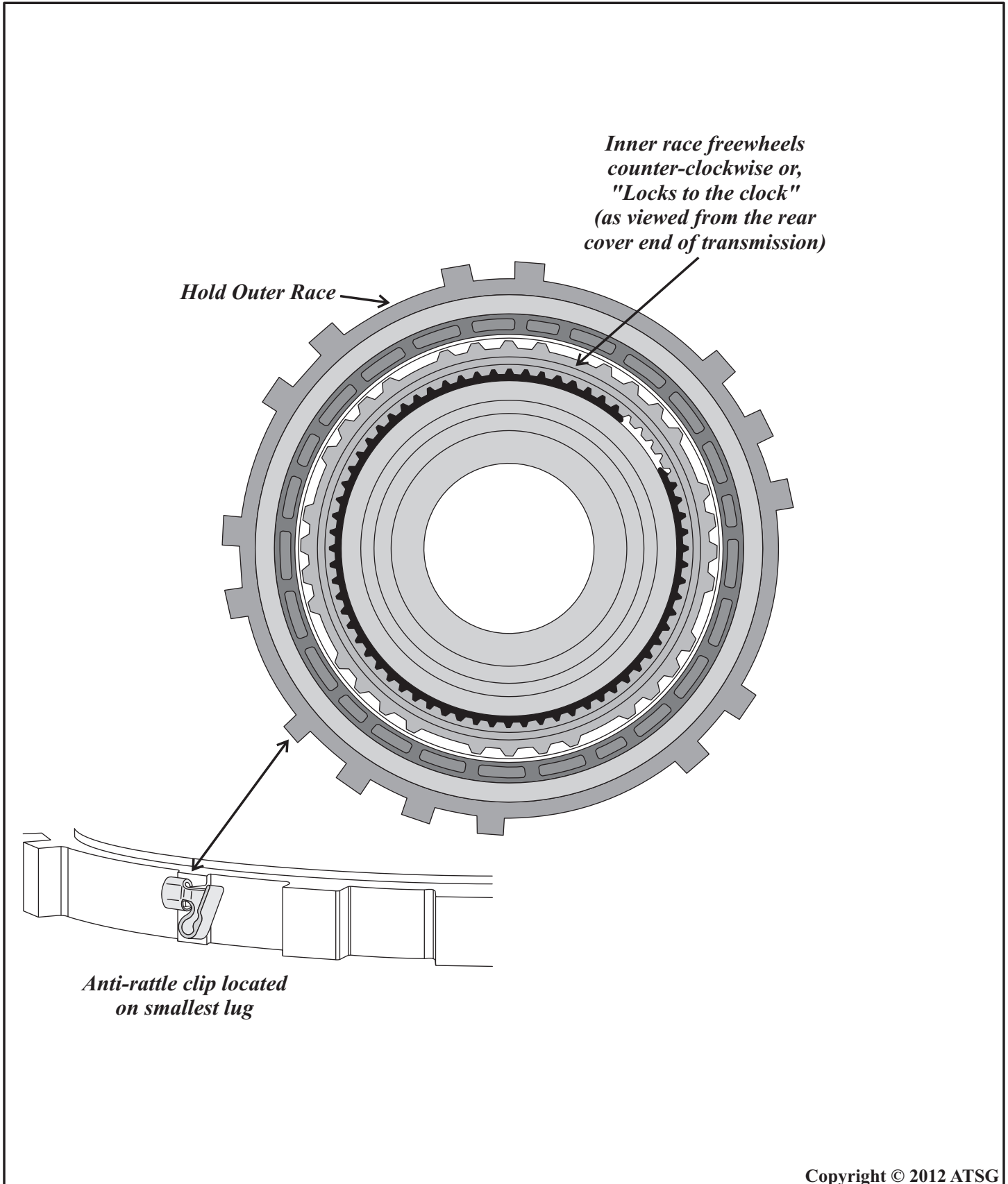

TOYOTA U660E PRESSURE TAP IDENTIFICATION

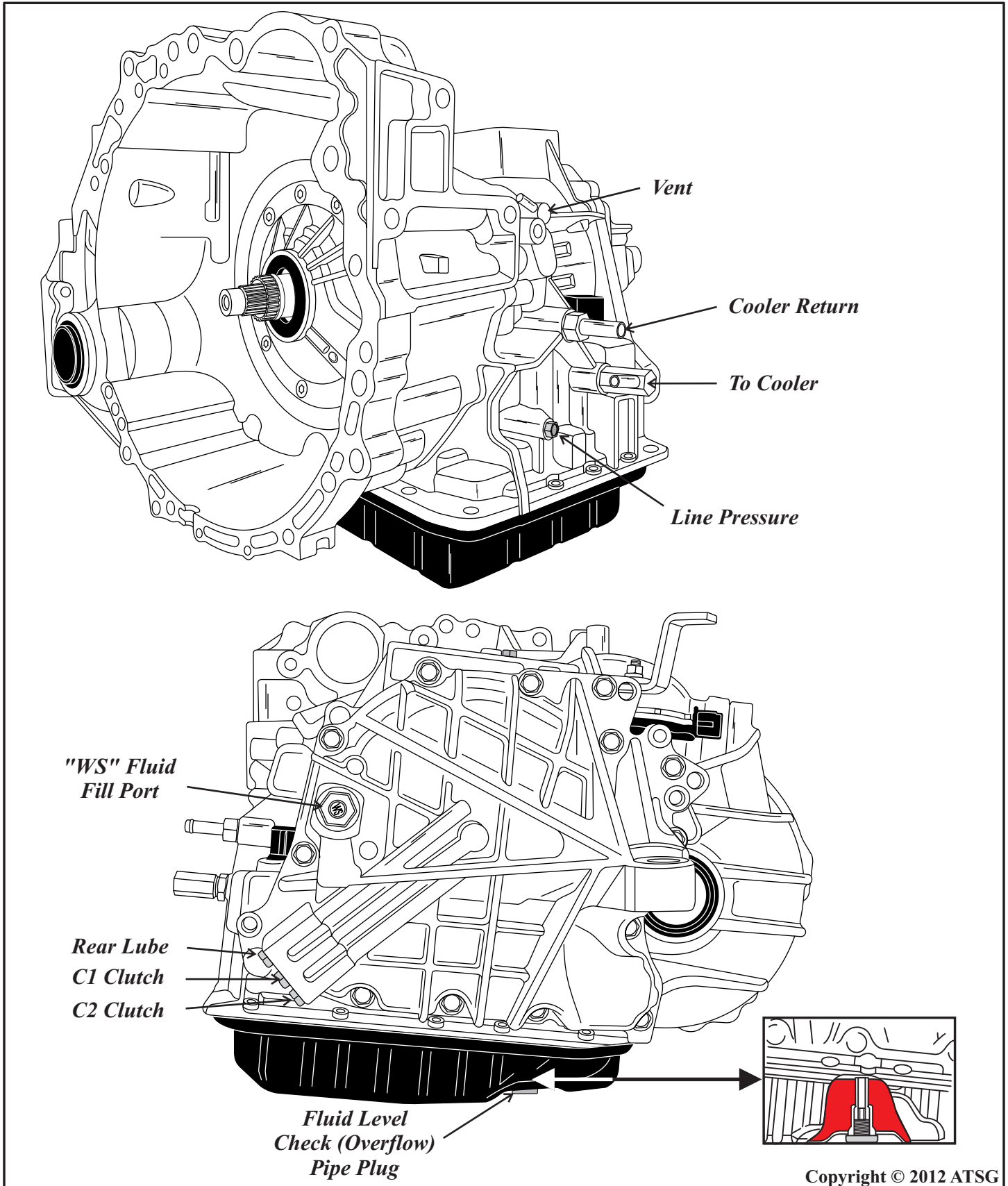

Copyright © 2012 ATSG