

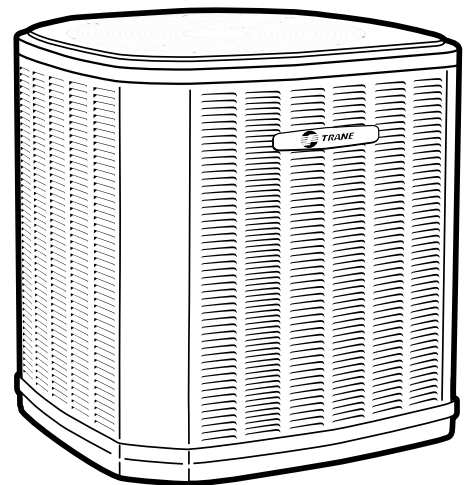

Product Data

Split System Cooling

4TTR4018L1000A
4TTR4024L1000B
4TTR4025L1000B
4TTR4030L1000A
4TTR4031L1000A
4TTR4036L1000A
4TTR4037L1000A
4TTR4042L1000A
4TTR4043L1000A
4TTR4048L1000A
4TTR4060L1000B



Note: "Graphics in this document are for representation only. Actual model may differ in appearance."



Product Specifications

Model No. ^(a)	4TTR4018L1000A	4TTR4024L1000B/ 4TTR4025L1000B	4TTR4030L1000A/ 4TTR4031L1000A	4TTR4036L1000A/ 4TTR4037L1000A
POWER CONNS. — V/PH/HZ ^(b)	208/230/1/60	208/230/1/60	208/230/1/60	208/230/1/60
MIN. BRCH. CIR. AMPACITY	12	14	17	18
BR. CIR. PROT. RTG. — MAX. (AMPS)	20	20	25	30
COMPRESSOR	CLIMATUFF®-SCROLL	CLIMATUFF®-SCROLL	CLIMATUFF®-SCROLL	CLIMATAUFF®-SCROLL
RL AMPS — LR AMPS	9 — 63	10.1 — 52	12.8— 68	14.1— 72
Outdoor Fan FL AMPS	0.60	0.90	0.77/.64	0.77/.64
Fan HP	1/15	1/8	1/8	1/8
Fan Dia (inches)	18.2	18.2	23.0	23.0
Coil	SPINE FIN™	SPINE FIN™	SPINE FIN™	SPINE FIN™
Refrigerant R-410A	4 LBS., 2 OZ	4 LBS., 11 OZ / 4 LBS., 2 OZ	4 LBS., 11 OZ	5 LBS., 8 OZ / 5 LBS., 3 OZ
LINE SIZE — IN. O.D. GAS ^(c)	3/4	3/4	3/4	3/4
LINE SIZE — IN. O.D. LIQ. ^(c)	3/8	3/8	3/8	3/8
Charge Spec. Subcooling	10°F	10°F	10°F	10°F / (8°F on 037)
Dimensions H x W X D Crated (IN.)	30.1 x 26.7 x 30	30.1 x 26.7 x 30	34 x 30.1 x 33	38 x 30.1 x 33
Weight — Shipping (lbs.)	153	153	183	183
Weight — Net (lbs.)	133	133	156	156
Optional Accessories:				
Anti-short Cycle Timer	TAYASCT501A	TAYASCT501A	TAYASCT501A	TAYASCT501A
Evaporator Defrost Control	AY28X079	AY28X079	AY28X079	AY28X079
Rubber Isolator Kit	BAYISLT101	BAYISLT101	BAYISLT101	BAYISLT101
Extreme Condition Mount Kit	BAYECMT023	BAYECMT023	BAYECMT023	BAYECMT023
Start Kit	BAYKSKT263	—	BAYKSKT263	BAYKSKT263
Crankcase Heater Kit	BAYCCHT302	BAYCCHT302	BAYCCHT302	BAYCCHT302
Seacoast Kit	BAYSEAC001	BAYSEAC001	BAYSEAC001	BAYSEAC001
Low Ambient Kit	BAYLOAM103	BAYLOAM103	BAYLOAM103	BAYLOAM103
Service Valve Panel Cover	TAYSVPAN-L0022AA	TAYSVPANL0022AA	TAYSVPANL0032AA	TAYSVPANL3343AA
Refrigerant Lineset ^(d)				

- ^(a) Certified in accordance with the Unitary Air-conditioner equipment certification program which is based on AHRI standard 210/240.
- ^(b) Calculated in accordance with N.E.C. Only use HACR circuit breakers or fuses.
- ^(c) Standard line lengths — 60', Standard lift — 60' Suction and Liquid line. For Greater lengths and lifts refer to refrigerant piping software Pub#32-3312-0* (* denotes latest revision).
- ^(d) 25, 30, 35 and 50 foot linesets available. For a complete listing of lineset options available from equipment or supply stores, refer to the Trane Residential and Light Commercial Product Handbook.

Product Specifications

Model No. ^(a)	4TTR4042L1000A/ 4TTR4043L1000A	4TTR4048L1000A	4TTR4060L1000B
POWER CONNS. — V/PH/HZ ^(b)	280/230/1/60	280/230/1/60	280/230/1/60
MIN. BRCH. CIR. AMPACITY	22	24	27
BR. CIR. PROT. RTG. — MAX. (AMPS)	35	40	45
COMPRESSOR	CLIMATUFF®- SCROLL	CLIMATUFF®- SCROLL	CLIMATUFF®- SCROLL
RL AMPS — LR AMPS	16.7 — 109	18.5 — 124	20.8 — 127.1
Outdoor Fan FL AMPS	1.05	1.05	1.05
Fan HP	1/5	1/5	1/5
Fan Dia (inches)	27.5	27.5	27.5
Coil	SPINE FIN™	SPINE FIN™	SPINE FIN™
Refrigerant R-410A	6 LBS., 2 OZ / 5 LBS., 5 OZ	5 LBS., 3 OZ	7 LBS., 10 OZ
LINE SIZE — IN. O.D. GAS ^(c)	7/8	7/8	7/8
LINE SIZE — IN. O.D. LIQ. ^(c)	3/8	3/8	3/8
Charge Spec. Subcooling	12°F	10°F	10°F
Dimensions H x W X D Crated (IN.)	34.4 x 35.1 x 38.7	34.4 x 35.1 x 38.7	42.4 x 35.1 x 38.7
Weight — Shipping (lbs.)	216	212	246
Weight — Net (lbs.)	184	189	211
Optional Accessories:			
Anti-short Cycle Timer	TAYASCT501A	TAYASCT501A	TAYASCT501A
Evaporator Defrost Control	AY28X079	AY28X079	AY28X079
Rubber Isolator Kit	BAYISLT101	BAYISLT101	BAYISLT101
Extreme Condition Mount Kit	BAYECMT004	BAYECMT004	BAYECMT004
Start Kit	BAYKSKT263	BAYKSKT263	BAYKSKT263
Crankcase Heater Kit	BAYCCHT301	BAYCCHT301	BAYCCHT301
Seacoast Kit	BAYSEAC001	BAYSEAC001	BAYSEAC001
Low Ambient Kit	BAYLOAM103	BAYLOAM103	BAYLOAM103
Service Valve Panel Cover			TAYSVPANL0044AA
Refrigerant Lineset ^(d)			

- (a) Certified in accordance with the Unitary Air-conditioner equipment certification program which is based on AHRI standard 210/240.
- (b) Calculated in accordance with N.E.C. Only use HACR circuit breakers or fuses.
- (c) Standard line lengths — 60', Standard lift — 60' Suction and Liquid line. For Greater lengths and lifts refer to refrigerant piping software Pub#32-3312-0* (* denotes latest revision).
- (d) 25, 30, 35 and 50 foot linesets available. For a complete listing of lineset options available from equipment or supply stores, refer to the Trane Residential and Light Commercial Product Handbook.



Product Specifications

Sound Power Level

Sound Power Level									
MODEL	A-Weighted Sound Power Level [dB(A)]	Full Octave Sound Power(dB)							
		63 Hz*	125 Hz	250 Hz	500 Hz	1000 Hz	2000 Hz	4000 Hz	8000 Hz
4TTR4018L1	71	74	71	65	68	67	63	56	50
4TTR4024L1 4TTR4025L1	71	74	71	65	68	67	63	56	50
4TTR4030L1 4TTR4031L1	71	73	73	72	69	68	60	52	45
4TTR4036L1 4TTR4037L1	71	73	73	72	69	68	60	52	45
4TTR4042L1 4TTR4043L1	71	81	72	69	69	66	60	57	54
4TTR4048L1	71	81	72	69	69	66	60	57	54
4TTR4060L1	71	81	72	69	69	66	60	57	54

Note: Rated in accordance with AHRI Standard 270-2008 *For Reference Only



Accessory Description and Usage

Anti-Short Cycle Timer — Solid state timing device that prevents compressor recycling until five (5) minutes have elapsed after satisfying call or power interruptions. Use in area with questionable power delivery, commercial applications, long lineset, etc.

Evaporation Defrost Control — SPST Temperature actuated switch that cycles the condenser off as indoor coil reaches freeze-up conditions. Used for low ambient cooling to 30°F with TXV.

Rubber Isolators — Five (5) large rubber donuts to isolate condensing unit from transmitting energy into mounting frame or pad. Use on any application where sound transmission needs to be minimized.

Hard Start Kit — Start capacitor and relay to assist compressor motor startup. Use in areas with marginal power supply, on long linesets, low ambient conditions, etc.

Extreme Condition Mount Kit — Bracket kits to securely mount condensing unit to a frame or pad without removing any panels. Use in areas with high winds, or on commercial roof tops, etc.

AHRI Standard Capacity Rating Conditions

AHRI Standard 210/240 Rating Conditions

1. Cooling 80°F DB, 67°F WB air entering indoor coil, 95°F DB air entering outdoor coil.
2. High Temperature Heating 47°F DB, 43°F WB air entering outdoor coil, 70°F DB air entering indoor coil.
3. Low Temperature Heating 17°F DB air entering indoor coil.
4. Rated indoor airflow for heating is the same as for cooling.

AHRI Standard 270 Rating Conditions — (Noise rating numbers are determined with the unit in cooling operations.) Standard Noise Rating number is at 95°F outdoor air.

Model Nomenclature

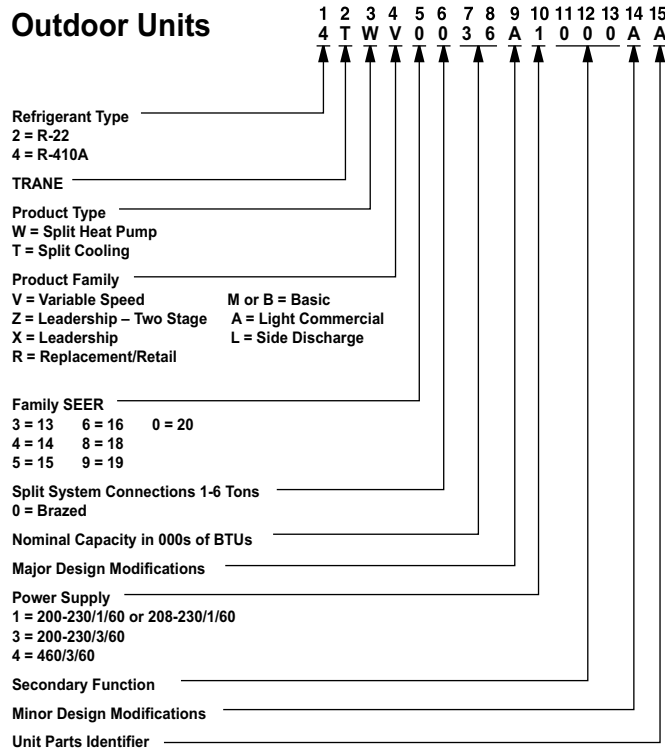

Schematic Diagrams

Figure 1. 1.5–4.0 Ton Models

TO POWER SUPPLY PER UNIT NAMEPLATE AND LOCAL CODES

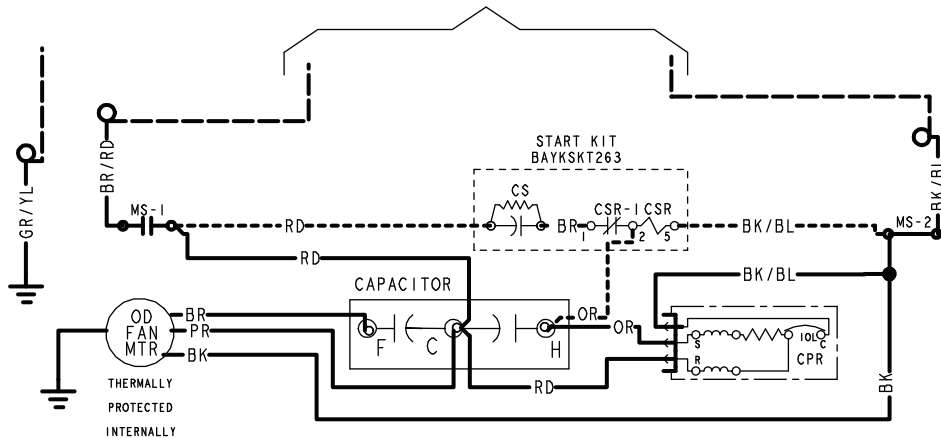

- CF FAN CAPACITOR
- CN WIRECONNECTOR
- CPR COMPRESSOR
- CR RUN CAPACITOR
- CS STARTING CAPACITOR
- CSR CAPACITOR SWITCHING RELAY
- F INDOOR FAN RELAY
- HPCO HIGH PRESSURE CUTOFF SWITCH
- LPCO LOW PRESSURE CUTOFF SWITCH
- IOL INTERNAL OVERLOAD PROTECTOR
- SM SYSTEM ON-OFF SWITCH
- MS COMPRESSOR MOTOR CONTACTOR
- ODA OUTDOOR ANTICIPATOR
- OFT OUTDOOR FAN THERMOSTAT
- ODS OUTDOOR TEMPERATURE SENSOR
- ODT OUTDOOR THERMOSTAT
- SC SWITCH OVER VALVE SOLENOID
- TDL DISCHARGE LINE THERMOSTAT
- TNS TRANSFORMER

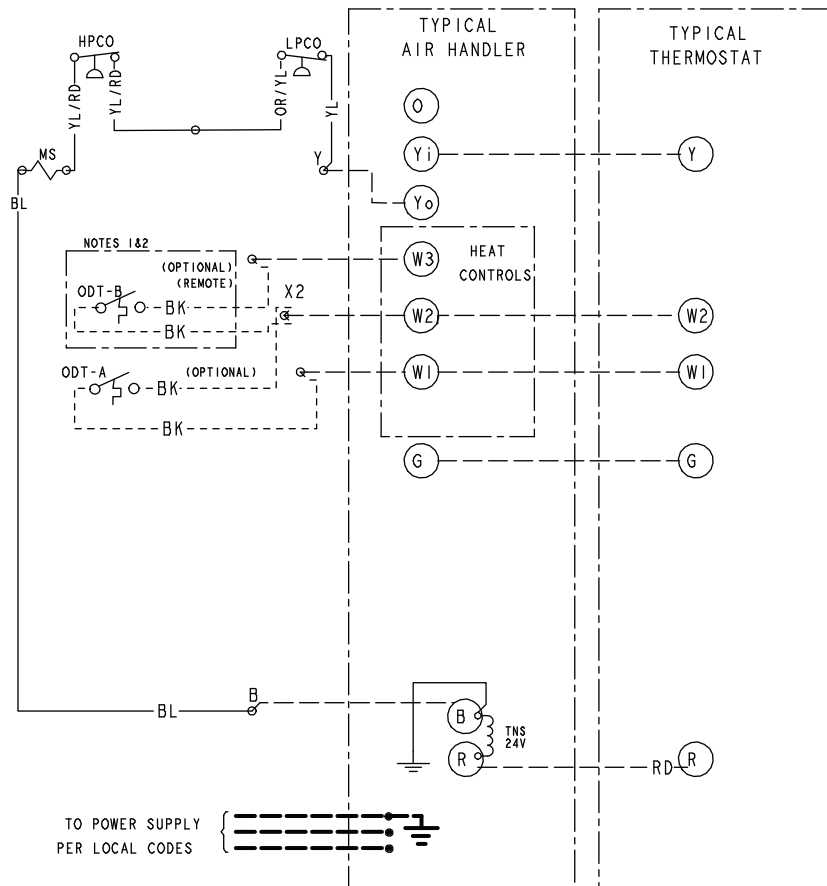

⚠ WARNING

HAZARDOUS VOLTAGE!
DISCONNECT ALL ELECTRICAL POWER INCLUDING REMOTE DISCONNECTS BEFORE SERVICING.

Failure to disconnect power before servicing can cause severe personal injury or death.

⚠ CAUTION

USE COPPER CONDUCTORS ONLY!
UNIT TERMINALS ARE NOT DESIGNED TO ACCEPT OTHER TYPES OF CONDUCTORS. Failure to do so may cause damage to the equipment.

COLOR OF WIRE
BK/BL
COLOR OF MARKER

- | | | |
|----------|-----------------|-----------|
| BK BLACK | RD RED | OR ORANGE |
| BL BLUE | WH WHITE | GR GREEN |
| BR BROWN | YL YELLOW | PR PURPLE |
| PK PINK | LTBL LIGHT BLUE | |

NOTES:

- IF ODT-B IS NOT USED, ADD JUMPER BETWEEN W2 & W3 AT AIR HANDLER. IF USED, ODT-B MUST BE MOUNTED REMOTE OF CONTROL BOX IN AN APPROVED WEATHER PROOF ENCLOSURE.
- IF ODT-A IS NOT USED, ADD JUMPER BETWEEN W1 & W2 AT AIR HANDLER.
- LOW VOLTAGE (24 V) FIELD WIRING MUST BE 18 AWG MIN.

FOR CANADIAN INSTALLATIONS
POUR INSTALLATIONS CANADIENNES

CAUTION: NOT SUITABLE FOR USE ON SYSTEMS EXCEEDING 150V-TO-GROUND
ATTENTION: NE CONVIENT PAS AUX INSTALLATIONS DE PLUS DE 150 V A LA TERRE

PRINTED FROM DI57362P03 REV00

Figure 2. 5.0 Ton Models

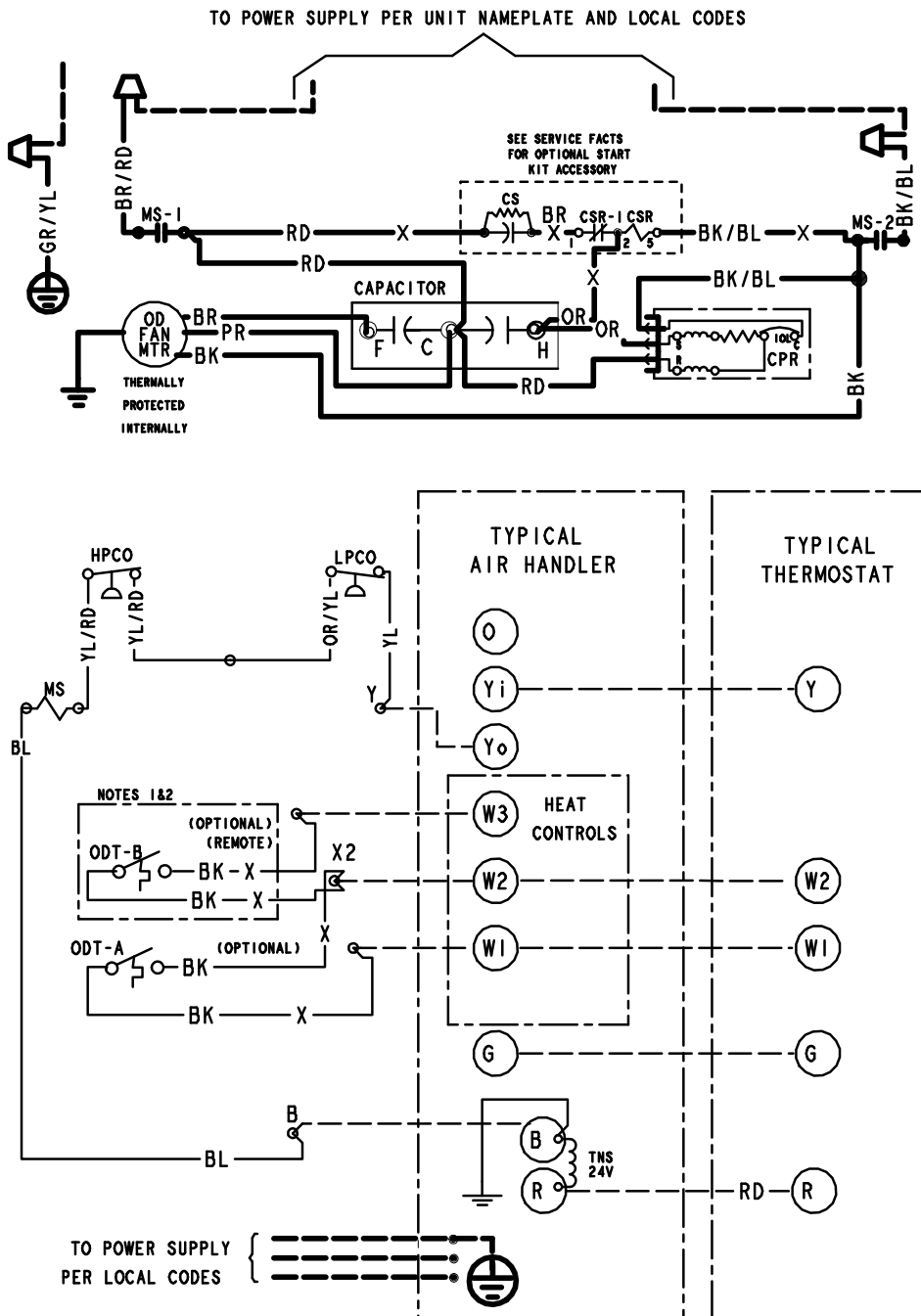

LEGEND

- CF FAN CAPACITOR
- CN WIRE CONNECTOR
- CPR COMPRESSOR
- CR RUN CAPACITOR
- CS STARTING CAPACITOR
- CSR CAPACITOR SWITCHING RELAY
- ODT OUTDOOR THERMOSTAT
- HPCO HIGH PRESSURE CUTOUT SWITCH
- LPCO LOW PRESSURE CUTOUT SWITCH
- MS COMPRESSOR MOTOR CONTACTOR
- TNS TRANSFORMER
- IOL INTERNAL OVERLOAD PROTECTOR

COLOR OF WIRE
 COLOR OF MARKER

- BK BLACK RD RED OR ORANGE
- BL BLUE WH WHITE GR GREEN
- BR BROWN YL YELLOW PR PURPLE
- PK PINK

FOR CANADIAN INSTALLATIONS
POUR INSTALLATIONS CANADIENNES

CAUTION: NOT SUITABLE FOR USE ON SYSTEMS EXCEEDING 150V-TO-GROUND
ATTENTION: NE CONVIENT PAS AUX INSTALLATIONS DE PLUS DE 150 V A LA TERRE

PRINTED FROM DI60439P01 REVA

Figure 3. 5.0 Ton Models

NOTES:

1. IF ODT-B IS NOT USED, ADD JUMPER BETWEEN W2 & W3 AT AIR HANDLER. IF USED, ODT-B MUST BE MOUNTED REMOTE OF CONTROL BOX IN AN APPROVED WEATHER PROOF ENCLOSURE.
2. IF ODT-A IS NOT USED, ADD JUMPER BETWEEN W1 & W2 AT AIR HANDLER.
3. LOW VOLTAGE (24 V) FIELD WIRING MUST BE 18 AWG MINIMUM.
4. USE COPPER CONDUCTORS ONLY!

LEGEND

- | | | | |
|--|------------------------|--|---|
| | 24 V } FACTORY | | RELAY CONTACT (N.O.) |
| | LINE WIRING | | RELAY CONTACT (N.C.) |
| | 24 V } FIELD | | THERMISTOR |
| | LINE WIRING | | TEMP ACTUATED SWITCH |
| | 24 V } FIELD INSTALLED | | INTERNAL OVERLOAD PROTECTION |
| | LINE WIRING | | PRESSURE ACTUATED SWITCH |
| | MAGNETIC COIL | | RESISTOR OR HEATING ELEMENT |
| | GROUND | | MOTOR WINDING |
| | JUNCTION | | POL. PLUG FEMALE HOUSING (MALE TERMINALS) |
| | CAPACITOR | | POL. PLUG MALE HOUSING (FEMALE TERMINALS) |
| | WIRE NUT OR CONNECTOR | | |
| | TERMINAL | | |
| | TRANSFORMER | | |
| | TERMINAL BLOCK/BOARD | | |

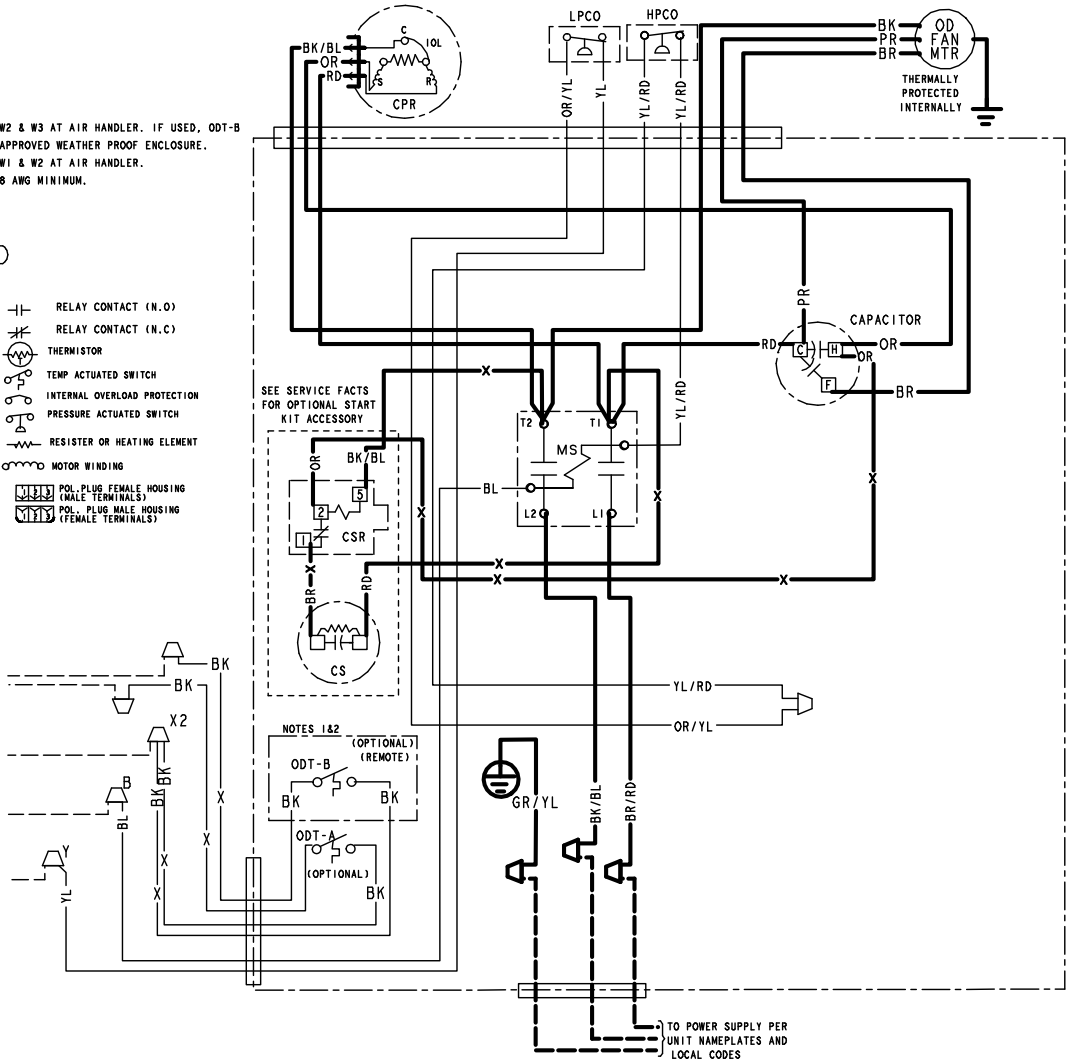

PRINTED FROM D160439P01 REVA



Outline Drawing

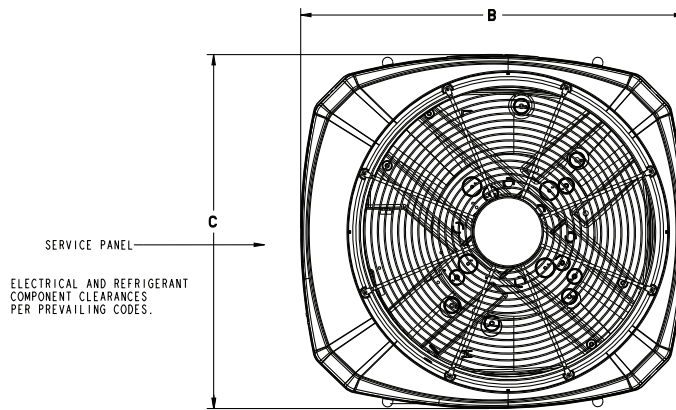

TOP DISCHARGE AREA SHOULD BE UNRESTRICTED FOR AT LEAST 1524 (5 FEET) ABOVE UNIT. UNIT SHOULD BE PLACED SO ROOF RUN-OFF WATER DOES NOT POUR DIRECTLY ON UNIT, AND SHOULD BE AT LEAST 305 (12") FROM WALL AND ALL SURROUNDING SHRUBBERY ON TWO SIDES. OTHER TWO SIDES UNRESTRICTED.

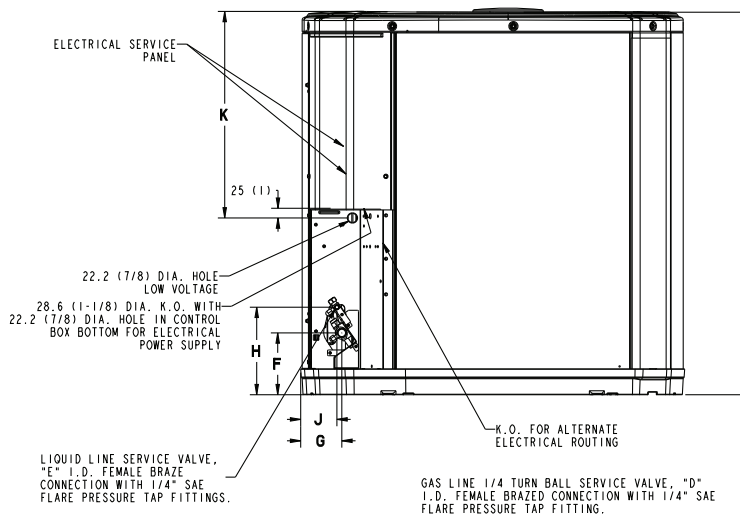

GAS LINE 1/4 TURN BALL SERVICE VALVE, "D" I.D. FEMALE BRAZED CONNECTION WITH 1/4" SAE FLARE PRESSURE TAP FITTING.

Model	Base	A	B	C	D	E	F	G	H	J	K
4TTR4018L	2	730 (28-3/4)	724 (28-1/2)	651 (25-5/8)	3/4	3/8	127 (5)	57 (2-1/4)	194 (7-5/8)	38 (1-1/2)	457 (18)
4TTR4024L 4TTR4025L	2	730 (28-3/4)	724 (28-1/2)	651 (25-5/8)	3/4	3/8	127 (5)	57 (2-1/4)	194 (7-5/8)	38 (1-1/2)	457 (18)
4TTR4030L 4TTR4031L	3	730 (28-3/4)	829 (32-5/8)	756 (29-3/4)	3/4	3/8	127 (5)	76 (3)	197 (7-3/4)	60 (2-3/8)	508 (20)
4TTR4036L 4TTR4037L	3	832 (32-3/4)	829 (32-5/8)	756 (29-3/4)	3/4	3/8	127 (5)	76 (3)	197 (7-3/4)	60 (2-3/8)	508 (20)
4TTR4042L 4TTR4043L	4	741 (29-1/8)	946 (37-1/4)	870 (34-1/4)	7/8	3/8	143 (5-5/8)	83 (3-1-4)	206 (8-1/8)	70 (2-3/4)	508 (20)
4TTR4048L	4	741 (29-1/8)	946 (37-1/4)	870 (34-1/4)	7/8	3/8	143 (5-5/8)	83 (3-1-4)	206 (8-1/8)	70 (2-3/4)	508 (20)
4TTR4060L	4	943 (37-1/8)	946 (37-1/4)	870 (34-1/4)	7/8	3/8	152 (6)	98 (3-7/8)	219 (8-5/8)	86 (3-3/8)	508 (20)



Mechanical Specification Options

General

The outdoor condensing units are factory charged with the system charge required for the outdoor condensing unit, ten (10) feet of tested connecting line, and the smallest rated indoor evaporative coil match. This unit is designed to operate at outdoor ambient temperatures as high as 115°F. Cooling capacities are matched with a wide selection of air handlers and furnace coils that are AHRI certified. The unit is certified to UL 1995. Exterior is designed for outdoor application.

Casing

Unit casing is constructed of heavy gauge, galvanized steel and painted with a weather-resistant powder paint finish. The corner panels are prepainted. All panels are subjected to our 1,000 hour salt spray test.

Refrigerant Controls

Refrigeration system controls include condenser fan, compressor contactor and low and high pressure switches. A factory supplied, field installed liquid line drier is standard.

Compressor

The compressor features internal over temperature and pressure protection. Other features include: Centrifugal oil pump and low vibration and noise.

Condenser Coil

The outdoor coil provides low airflow resistance and efficient heat transfer. The coil is protected on all four sides by louvered panels.

Low Ambient Cooling

As manufactured, this system has a cooling capacity to 55°F. The addition of an evaporator defrost control permits operation to 40°F. The addition of an evaporator defrost control with TXV permits low ambient cooling to 30°F.

The addition of the BAYLOAM107A low ambient kit permits ambient cooling to 20°F.

Thermostats—Cooling only and heat/cooling (manual and automatic change over). Sub-base to match thermostat and locking thermostat cover.



Trane - by Trane Technologies (NYSE: TT), a global innovator - creates comfortable, energy efficient indoor environments for commercial and residential applications. For more information, please visit trane.com or tranetechnologies.com.



The AHRI Certified mark indicates Trane U.S. Inc. participation in the AHRI Certification program. For verification of individual certified products, go to ahridirectory.org.

Trane has a policy of continuous data improvement and it reserves the right to change design and specifications without notice. We are committed to using environmentally conscious print practices.