

E. F. JOHNSON CO.

VIKING 6N2

SIX and TWO  
METER VFO



Introduction to the  
JOHNSON VIKING 6N2 METER VFO  
Assembly, Calibrating and Operating  
Instructions

Good workmanship and careful adherence to instructions are necessary in the building and operating of the 6N2 Meter Variable Frequency Oscillator. Although the design of this VFO was carried out with the objective of reducing the number of critical circuits to a minimum and making assembly simple, the capacitor and inductor values of the tuned circuit components were necessarily chosen with a given parts layout; therefore, the builder should duplicate the layout shown in the illustrations and described in this test. Circuits should be checked against the schematic diagram during the several steps of assembly. Much time and effort may be saved by finding an error or deviation from the illustrated layout before the unit is completed. Read each step through before commencing the operation.

The letter (S) appearing in the instructions means "solder". The letters (NS) "do not solder". After completing each operation, check it off in the box ( ) provided. Do not use excess solder as it may cause shorts. Correct soldering procedure calls for heating the joint first and then applying solder to the hot joint (not to the soldering iron). Use good Rosin Core solder and keep the soldering iron hot and clean to assure good connections.

The accuracy of frequency adjustments will be largely determined by the amateur's requirements and the standard he has available. The calibrating instructions should be understood before attempting to make initial frequency adjustments. After the frequency setting and adjustments have been completed to the satisfaction of the user, there is little reason to expect much change with time; however, it is always wise to check the frequency calibration frequently if the VFO dial scale is depended upon for determining the frequency of the transmitter.

The Viking 6N2 Meter VFO has only two controls. A little care in noting the position of the tuning dial before completing transmitter tuning will assure the operator of a correct frequency. The operating instructions are very simple but important. Be certain they are understood before using the VFO.

WARNING

The Viking 6N2 Meter VFO derives its power from the transmitter low voltage power supply or an auxiliary supply. The B+ source to the VFO must be off to remove the 250 to 300 volts in the VFO. Take care to avoid shock.

# STANDARD WARRANTY

Adopted and Recommended by the  
Electronic Industries Association

The E. F. Johnson Company warrants each new radio product manufactured by it to be free from defective material and workmanship and agrees to remedy any such defect or to furnish a new part, except for electron tubes, in exchange for any part of any unit of its manufacture which under normal installation, use and service disclosed such defect, provided the unit is delivered by the owner to us or to our authorized radio dealer or wholesaler from whom purchased, intact, for our examination, with all transportation charges prepaid to our factory (return transportation charges also to be paid by owner) within ninety days from the date of sale to original purchaser and provided that such examination discloses, in our judgement, that it is thus defective.

This warranty does not extend to any of our radio products which have been subjected to misuse, neglect, accident, incorrect wiring not our own, improper installation, unauthorized modifications, or to use in violation of instructions furnished by us, nor extend to units which have been repaired or altered outside of our factory, nor to cases where the serial number thereof has been removed, defaced or changed, nor to accessories used therewith not of our own manufacture, nor to electron tubes.

The Radio Parts Distributor will assume the responsibility for replacement or exchange of any component part of a unit approved for remedy or exchange hereunder, through the factory Customer Service Department, without charge to the owner.

Defective electron tubes and executed service reports, carefully packed, should be returned prepaid directly to the tube manufacturer for adjustment at the following addresses. Ship power tubes via Railway Express.

NOTE: Tubes marked "E. F. Johnson Co.," regardless of manufacturer, should be returned to E. F. Johnson Co., Waseca, Minnesota.

(a) RCA tubes to: Adjustment Service, RCA at the nearest of the following addresses:

34 Exchange Place  
Jersey City 2, N. J.

3601 South Adams St.  
Marion, Indiana

6355 East Washington Blvd.  
Los Angeles 22, California

(b) General Electric tubes to:

Adjustment Service  
Owensboro Tube Works  
General Electric Co.  
Owensboro, Kentucky

(c) Amperex tubes to:

Amperex Electronic Corp.  
230 Duffey Avenue  
Hickville, Long Island  
New York

(d) Eimac tubes to:

Eitel-McCullough, Inc.  
San Bruno,  
California

(e) Sylvania tubes to:

Sylvania Electric Products  
Dept. EFJ  
2001 North Cornell  
Melrose Park, Illinois

(f) Penta tubes to:

Penta Laboratories, Inc.  
312 North Nopal Street  
Santa Barbara, California

This warranty is in lieu of all other warranties expressed or implied and no representative or person is authorized to assume for us any other liability in connection with the sale of our radio products.

# JOHNSON VIKING 6N2 METER VFO

## CONTENTS

	<u>Page</u>
1. CHASSIS COMPONENT ASSEMBLY	1
2. UNDERCHASSIS WIRING	2
3. TOP CHASSIS WIRING	5
4. PRELIMINARY TESTS AND CHECKOUT	6
5. CABINET, POINTER AND PANEL ASSEMBLY	7
6. TWO METER CALIBRATION	8
7. TEMPERATURE COMPENSATION ADJUSTMENT	10
8. SIX METER CALIBRATION	11
9. OPERATION	12
10. ILLUSTRATIONS	
11. PARTS LIST	Following Illustrations

## 1. CHASSIS COMPONENT ASSEMBLY

Refer to Figures 1 thru 3B. Do not solder connections until instructed to do so. It should be noted that all wire connections and components are not shown in Figures 1 thru 3B. Follow directions implicitly.

- a. ( ) Install rubber grommets G1, G2, G3 and G4 in the chassis (see Figures 1A, 2A, and 3A).
- b. ( ) Mount XV1 (7 pin miniature socket for 6BH6 oscillator). Use two 1/4" x 4-40 screws, two #4 shakeproof washers, a #6 teardrop solder terminal and two 4-40 nuts. Position as shown in Figure 2A, using the following hardware sequence (from the topside of the chassis): 3/16" x 4-40 screws, socket mounting foot, chassis, #4 shakeproof washer, #6 teardrop ("A" as shown in Figure 2A), 4-40 nut. Tighten securely.
- c. ( ) Using diagonal cutters, cut off pins 2, 3, 6 and 7 close to the base of XV2 (miniature socket for OA2 voltage regulator). Only pins 1, 4 and 5 will be used in wiring.
- d. ( ) Mount XV2 in the same manner as XV1 above. Bend pins 1 and 4 down toward the chassis to horizontal position. Pin 4 should be bent toward the adjacent teardrop "F".
- e. ( ) Mount TS2 (6 terminal strip) as shown in Figure 2A using the following sequence (from the topside of the chassis): 1/4" x 6-32 screw, chassis, #6 shakeproof washer, TS2 mounting foot, #6 shakeproof washer, #6 teardrop ("C" in Figure 2A), 6-32 nut.
- f. ( ) Mount the pilot light mounting spacer, HW1, (1/4" x 3/4" aluminum rod) using the following sequence (from the top of the chassis): 1/4" x 6-32 screw, chassis, #6 shakeproof washer, mounting spacer. See Figures 2A and 3B.
- g. ( ) Mount capacitor bracket BKT1 on top of the chassis (as shown in Figure 1A) using the following sequence: 1/4" x 6-32 screw, bracket foot, chassis, #6 shakeproof washer, #6 teardrop ("E" as shown in Figure 2A), 6-32 nut. Keep bracket straight and tighten securely.
- h. ( ) Mount C1 (large variable capacitor) on top of the chassis (as shown in Figure 1A) using the following sequence (from the underside of the chassis): 3/16" x 6-32 round head screw, #6 shakeproof washer, chassis, C1 mounting foot. Very carefully center C1 so that the shaft is at right angles to the front of the chassis. Tighten securely.
- i. ( ) Mount TS1 (2 terminal strip) on top of the chassis as shown in Figure 1A using a 1/4" x 6-32 screw, a #6 shakeproof washer and a 6-32 nut (screwhead on top of chassis).
- j. ( ) Attach two 6-32 spade lugs to ceramic oscillator coil (L1) using the following sequence (with the head of the 1 3/8" x 6-32 screw on the terminal side of the coil): 1 3/8" x 6-32 screw head, 6-32 spade lug, #6 flat fiber washer, coil form, #6 flat fiber washer, 6-32 spade lug, #6 shakeproof washer, 6-32 nut. Tighten carefully with spade lugs straight in line with coil form. (Do not tighten excessively as damage to the ceramic form may result).
- k. ( ) Mount L1 on top of the chassis with the terminals of L1 toward the capacitor bracket (BKT1) using two #6 shakeproof washers, two #6 teardrops and two 6-32 nuts. Orient the teardrops ("B" and "D") as shown in Figure 2A and tighten carefully.



1. 1. ( ) Mount C3 (20M11 miniature variable capacitor - rotor lug to the left, viewed from shaft end with stator down) in the hole nearest the chassis of the capacitor bracket (BKT1). The stator should be away from the chassis. See Figures 1A and 1B. Place the 1/4" inside diameter metal washer between the shoulder of the capacitor bushing and the bracket. Secure tightly with the nut.
  - m. ( ) Mount C2 (20M11 variable capacitor - rotor lug to the right, viewed as above) in the middle hole of BKT1 using the phenolic shoulder washer and three thin phenolic washers to insulate the capacitor from the bracket. Place the shoulder washer on the threaded bushing of the capacitor with the small diameter of the washer toward the bracket. The three thin phenolic washers should be placed on the opposite side of the bracket. The stators of C2 and C3 should be back to back with the stator lugs touching. Bend stator lugs as necessary. Secure carefully with the hex nut.
  - n. ( ) Mount C23 (19MA11 variable capacitor) in the upper hole in BKT1 with the rotor terminal toward C2. Secure tightly with the nut supplied.
  - o. ( ) Slip a 1/4" I.D. teardrop over the threaded bushings of C9, C10 and C11 (9M11 miniature variable capacitors). Bend the teardrops toward the rotor lugs of the 9M11's. Connect the teardrops to the capacitor rotor lugs using a short length of #18 tinned wire. Solder all connections.
  - p. ( ) Mount C9, C10 and C11 as shown in Figure 3A. Tighten securely.
  - q. ( ) Install dial drive assembly D1 (shaft and bushing) as shown in Figures 2B and 3B. Secure the drive assembly with a 3/8" internal tooth lockwasher and 3/8-32 nut on inside of chassis.
2. UNDERCHASSIS WIRING: See Figures 1 thru 3B in the following steps.
    - a. ( ) Using a 1 1/4" length of #18 tinned wire, connect the center shield (S) and pins 3 and 7 of XV1 (NS) to the teardrop ("A") nearest pin 3 of XV1 (NS).
    - b. ( ) Bend the teardrop ("F") and pin 4 of XV2 together and connect together with short length of #18 tinned wire (S).
    - c. ( ) Cut a 4 1/2" length of red plastic-covered wire and strip 5/16" on both ends. Connect one end to the top terminal of L1 (NS). Route the lead through grommet G1 and train along the chassis. Connect the other end to terminal 1 of TS2 (NS).
    - d. ( ) Cut a 2 1/4" length of green plastic-covered wire and strip 5/16" on both ends. Connect one end to pin 4 of XV1 (NS) and connect the other end to terminal 3 of TS2 (NS).
    - e. ( ) Cut a 5 1/2" length of yellow plastic-covered wire and strip 5/16" on each end. Connect one end to pin 5 of XV2 (S). Route the lead against front edge of chassis. Connect the other end to pin 6 of XV1 (NS).
    - f. ( ) Cut a 4" length of black plastic-covered wire. Strip 5/16" on both ends, route through grommet G1 and along chassis to XV1. Connect one end to pin 2 of XV1 (NS) and the other end to the insulated terminal of TS1 on top of the chassis (NS).
    - g. ( ) Cut one lead of R2 (18,000 ohms 2 watt resistor - brown, gray, orange.) to 3/4" and the other lead to 1 1/4". Cut a 3/4" length of varnished tubing and slip it over the 1 1/4" lead. Connect the 3/4" lead to pin 1 of XV2 (S). Train the resistor body against the chassis. Connect the 1 1/4" lead to terminal 2 of TS2 (NS).

2. h. ( ) Install bandswitch SW1 (rotary switch) in the chassis hole near XV2 with a 3/8" shakeproof washer on the inside of the chassis. Orient the switch so the long contact is over grommet G4. See Figure 3B.
- i. ( ) Cut a 3 1/2" length of red plastic-covered wire and strip 5/16" on both ends. Connect one end to pin 5 of XV1 (S). Route the lead as shown in Figure 2B and connect the other end to terminal 6 of TS2 (NS).
- j. ( ) Mount the dial light socket (XI1) on the tapped spacer (HW1) using a 1/4" x 6-32 binding head screw and #6 shakeproof washer. Extend the front edge of the socket 1/4" through the hole in the chassis and tighten the screw securely. See Figures 2B and 3B.
- k. ( ) Cut a 1 3/4" length of green plastic-covered wire and strip 5/16" on both ends. Connect one end to the terminal on XI1 (S) and the other end to terminal 3 of TS2 (NS).
- l. ( ) Cut a 1 3/4" length of #18 tinned wire. Connect to the rotor terminal of C1, (NS), route down thru grommet G1 and connect to the teardrop ("D") near grommet G1 (NS).
- m. ( ) Cut the leads of C16 (.005 mfd. ceramic disc capacitor) to 3/8" and connect between pin 7 and 6 of XV1 (S).
- n. ( ) Cut both leads of C14 (.005 mfd. disc capacitor) to 5/8". Connect between terminal 5 of TS2 (NS) and the teardrop ("C") under the rear mounting foot of TS2 (S). Orient C14 as shown in Figure 2B.
- o. ( ) Cut the leads of C17 (.005 mfd. disc capacitor) to 1/2" and connect between terminal 2 of TS2 (NS) and the teardrop ("A") near pin 3 of XV1 (NS).
- p. ( ) Cut the leads of C15 (.005 mfd. disc capacitor) to 3/8" and connect between pins 3 and 4 of XV1 (S).
- q. ( ) Cut the leads of C18 (.005 mfd. disc capacitor) to 1/2" and connect between terminal 4 of TS2 (NS) and the teardrop ("D") nearest grommet G1 (S).
- r. ( ) Cut the leads of R1 (47,000 ohm 1/2 watt resistor - yellow, violet, orange) to 1/2" and connect between pin 1 of XV1 (NS) and the teardrop ("A") adjacent to pin 3 of XV1 (S).
- s. ( ) Cut the leads of C4 (43 mmfd. tubular ceramic capacitor - black, yellow, orange, black, orange) to 1/2" and connect between pin 1 of XV1 (S) and terminal 1 of TS2 (S).
- t. ( ) Prepare the ends of the three conductor shielded cable as shown in Figure 5. Insert the end of the three conductor shielded cable through G3 (the grommet nearest the top of the chassis) before attaching the #18 tinned lead. Attach and solder the #18 tinned lead. Connect the leads as follows:
  - (1) #18 tinned lead to the teardrop ("B") under the outside mounting lug of L1 (S). See Figure 2B.
  - (2) White-black (or black) lead to terminal 5 of TS2 (NS).
  - (3) White lead to terminal 3 of TS2 (S).
  - (4) Red lead to terminal 2 of TS2 (NS).

2. u. ( ) Slip the cover of P1 over the cable and then connect the cable of P1 as described in Figure 5 (S). Snap the cover onto P1.
- v. ( ) Cut the leads of L4 (single pi. R.F. choke) to 3/4". Bend the leads at the right angles to the choke and connect one end to terminal 2 of TS2 (S). Connect the other end to terminal 4 of TS2 (NS). Orient this choke up above TS2.
- w. ( ) Cut the leads of L3 (3.3 uhy. R.F. choke - resembles a resistor) to 3/4" and connect between terminals 4 and 6 of TS2 (NS). Orient this choke to the side of TS2 as shown in Figure 2B.
- x. ( ) Mount C20 (the mica-insulated trimmer capacitor) on the inside of the chassis back as follows: 1/4" x 6-32 screw, chassis, C20 mounting foot, #6 shakeproof, #6 teardrop (orient as in Figure 3A), 6-32 nut.
- y. ( ) Cut the leads of C19 (.005 mfd. disc capacitor) to 1/2" and connect one lead to terminal 6 of TS2 (NS). Connect the other lead to the terminal of C20 nearest grommet G1 (NS). See Figure 3A.
- z. ( ) Cut a 2" length of #18 tinned wire and connect one end to the stator terminal of C11 (9M11 variable capacitor) (S). Connect the other end to terminals 9 of SW1 (S).
- aa. ( ) Cut a 2 1/4" length of #18 tinned wire. Connect one end to the stator terminal of C10 (9M11) (S). Connect the other end to terminals 8 of SW1 (S).
- bb. ( ) Cut a 2 1/4" length of #18 tinned wire. Connect one end to the stator terminal of C9 (9M11) (S). Connect the other end to terminals 7 of SW1 (S).
- cc. ( ) Cut the leads of R3 (5600 ohm 1/2 watt resistor - green, blue, red) to 5/8" and bend the leads at right angles to the resistor body. Connect between terminals 4 and 6 of TS2 (S).
- dd. ( ) Cut the leads of L2 (4 pi R.F. choke) to 3/4" and connect one lead to pin 2 of XV1 (S). Connect the other lead to terminal 5 of TS2 (S). Orient this choke parallel to and about 1/2" away from TS2.
- ee. ( ) Cut the leads of C12 (27 mmfd. - NPO capacitor) to 3/8" and connect between terminals 12 of SW1 (S) and the adjacent teardrop (S). See Figure 3B.
- ff. ( ) Prepare the RG-59/U cable as shown in Figure 4. Insert the end of the cable through the remaining grommet (G2) in the rear of the chassis. Connect the center conductor to the terminal of C20 nearest G1 (S). Connect the shield lead to the other terminal of C20 (S) and then to the teardrop on the mounting foot of C20 (S). See Figure 3A.
- gg. ( ) The other end of this Rg-59/U output cable should be attached to P1 (see Figure 4) if it is to be used with the 6N2 or a similar arrangement (i.e. with the VFO output connection thru the octal plug P1.) Insert the cable thru the plug cover and insert and solder the center conductor to pin 5 of P1 and the shield braid lead in pin 4 of P1.  
  
However, if it is desired to plug the VFO output into a crystal socket, the two prong plug (P2) should be connected to this end of the RG-59/U cable.
- hh. ( ) This completes the underchassis connections, check carefully for any unsoldered and cold solder joints.



3. TOP CHASSIS WIRING: See Figure 1B.

- a. ( ) Connect a 1 1/4" length of #18 tinned wire between the rotor terminal of C1 (NS) and the rotor terminal of C3 (the 20M11 miniature capacitor nearest the chassis (NS)).
- b. ( ) Cut the leads of C6 (500 mmfd. silver mica capacitor) to 5/8". Wrap one of the leads around the rotor terminal of C1 (S) and connect the other lead to the insulated terminal of TS1 (NS). Orient C6 as in Figure 1B.
- c. ( ) Connect one end of a 1 7/8" length of #18 tinned wire to the stator terminals of C2 and C3 (20M11 miniature variable capacitors) by securing the two terminals together with a loop on the end of the wire (NS). Connect the other end of the lead to the bottom terminal of L1 (S).
- d. ( ) Connect a 2" length of #18 tinned wire between terminal 10 of SW1 (route up through grommet G4) and the #18 wire installed in the previous step (S). See Figures 1B and 3B.
- e. ( ) Connect a 1 3/8" length of #18 tinned wire between the stator terminal of C1 (S) and the rotor terminal of C2 (the 20M11 miniature capacitor mounted with insulated washers) (S).
- f. ( ) Cut the leads of C7 (11 mmfd. - N330 ceramic capacitor) and C8 (10 mmfd. NPO ceramic capacitor) to 3/8". Connect one lead of each capacitor to the #18 wire near the rotor terminal of C3 (NS). Connect the remaining leads of C7 and C8 to the #18 wire which is connected to the stator terminals of C2 and C3 (NS). See Figure 1B.
- g. ( ) Cut the leads of C13 (51 mmfd. - NPO ceramic capacitor) to 5/8". Connect one lead to the center of the #18 wire which is connected between the rotor of C2 and the stator of C1 (S). Connect the other lead to the center of the #18 wire which is connected between the two 20M11 stator terminals (C2 and C3) and the bottom terminal of L1 (S).
- h. ( ) Connect a 2" length of #18 tinned wire between the rotor terminal of C3 (S) and the rotor terminal of C23 (S). Train this lead as shown in Figure 1B.
- i. ( ) Cut the leads of C5 (500 mmfd. silver mica capacitor) to 5/8". Connect one end to the top terminal of L1 (S) and the other end to the insulated terminal of TS1 (S).

Be sure that all the leads in the previous steps are properly soldered.

- j. ( ) Cut the leads of C22 (12 mmfd. - N750 ceramic capacitor) to 1" in length and connect between the stator terminal of C23 nearest L1 (S) and the #18 wire which is connected to the stator terminal of C2 and C3 (S). See Figure 1B.
- k. ( ) Cut the leads of C21 (12 mmfd. - NPO ceramic capacitor) to 1" and connect it between the remaining stator terminal of C23 (S) and the stator terminal of C2 and C3 (S). See Figure 1B.

This completes the wiring. Check carefully for any unsoldered connections, shorts or errors.

- l. ( ) Place C1 (main tuning capacitor) in fully meshed position. Install two 8-32 set screws in dial drive pulley (D2) and place D2 on the shaft of C1 with the flat surface of the pulley toward C1. Position D2 so there is 1/8" spacing between the rear of D2 and the front of the chassis, with the pulley rim opening pointing toward D1 (panel bearing and shaft assembly). Tighten the set screws securely.

3. m. ( ) The dial cord is strung as shown in Figure 8. Pass one end of the dial cord (D3) through the loop of D4 (dial cord tension spring) and tie the end of the cord securely using a double knot. Slip the other loop of D4 over the upper right ear tab of pulley D2 with the dial cord passing through the rim opening. Slip the remaining spring (D5) over the upper left ear tab. With capacitor C1 fully meshed, grasp the pulley with one hand to prevent rotation and draw the cord through the rim opening so that tension is on spring D4 (evidenced by slight parting of coil turns). Draw the cord around the pulley rim in a counter-clockwise direction keeping tension on the cord. (Keep the cord toward the rear rim of the pulley to provide room for a second turn.) When approximately three-quarters of a turn has been made around the pulley, draw the cord down around the shaft of the panel bearing assembly and make approximately two and one-half turns in a counter-clockwise direction.

Draw the cord up to the pulley rim (in front of the previous turn), around the rim counter-clockwise and through the rim opening. Clamp the cord to the rim with one hand and pass the free end of the cord through the unused loop of spring D5. Draw the cord back through the rim opening, putting observable tension on D5. Clamp the cord at the spring loop with one hand and with the other hand tie an overhand knot tight against the spring loop. Tie a second and third knot tight against the preceding knots. Both springs should be under tension - if not, restring the dial cord until they are.

Be sure to keep the cord taut during the stringing operation. Grasp the drive shaft and rotate C1 through several complete cycles to check overall dial cord drive. If operation is satisfactory, cut away excess cord. If not, restring the dial cord until satisfactory operation is obtained.

- n. ( ) The maroon dial backing plate should now be attached to the front of the chassis using the two 1/2" tubular spacers to space the plate away from the chassis. Place the large hole in the plate over the shaft of C1 with the maroon finish away from C1 and with the small holes toward the switch and tuning drive shafts. Position a spacer between the plate and the front of the chassis. Insert a 3/4" x 6-32 screw from the front and secure with a #6 shakeproof and 6-32 nut on the inside of the chassis. With both screws attached, center the hole relative to the shaft of C1 and tighten both screws securely.
- o. ( ) The shaft of C2, C3, C9, C10, C11 and C23 (miniature variable capacitors) are slotted to permit screwdriver adjustment. The shaft ends should be marked so that it will be possible to determine the position of the capacitors after the unit is enclosed in the cabinet. Place these capacitors in the full mesh position. (Except C23, turn its rotor so it is half meshed with each stator and the rotor blades are toward the chassis) and then paint the bottom half of the shaft end with colored fingernail polish, ink or other marking. The approximate mesh position of each capacitor may now be determined by observation of the shaft end.

#### 4. PRELIMINARY TESTS AND CHECKOUT

- a. ( ) Place the 6BH6 tube in socket XV1 and the OA2 tube in socket XV2. The #47 dial lamp should be placed in the pilot light socket. Place tube shields over the tubes.
- b. ( ) Temporarily attach the knobs to the switch and tuning control shafts. Place switch SW1 in the extreme clockwise position and tuning capacitor C1 at half capacity. If the VFO is to be operated with equipment other than a "6N2", pins 1 and 8 of P1 should be shorted together, thus providing a ground return for the cathode of the 6BH6.
- c. ( ) Plug P1 into the VFO socket (J5) of the "6N2" or into any power supply which provides 6.3 volts at .3 amps and 250-300 volts D.C. at 15 ma. CAUTION: One side of the 6.3 volt filament is grounded in the VFO, therefore the filament supply should not have a grounded centertap (because the filament winding will be shorted).



4. d. ( ) Turn the power supply ON. Check to see that the 6BH6 filament and the pilot lamp light. A violet glow should be observed between the electrodes of the OA2.
  - e. ( ) Set all trimmer capacitors, at mid-position. Wrap one end of a 2 foot length of wire around the RG-59/U cable from the VFO.
  - f. ( ) Tune a receiver to approximately 8100 kc and turn ON the beat frequency oscillator (BFO). Couple the VFO antenna lead loosely to the receiver (a few inches from the receiver antenna terminal).
  - g. ( ) Tune the VFO tuning capacitor (C1) through its full range slowly. The VFO signal should be heard beating with the receiver BFO.
  - h. ( ) If no beat is heard in the previous step, first couple the VFO more closely to the receiver and tune again for the beat note. If still no signal is heard, try setting C2 and C3 at various positions, tuning through the full range after each resetting. Check both filament and B+ supply voltages, check for cold soldered joints, check tightness of all screws at teardrop grounding points and check that SW1 is turned clockwise (2 meter position).
  - i. ( ) When the VFO signal has been heard beating with the receiver BFO, the VFO is considered to be basically operating. Proceed to the next step after removing the knobs.
5. CABINET, POINTER AND PANEL ASSEMBLY: See Figure 6.
- a. ( ) Push the RF output and power plug (P1) through the 1 5/16" diameter hole in the back of CH2 (cabinet back and sides). Draw the cables through the opening until the back of the chassis is touching the cabinet.
  - b. ( ) Spread apart the front flanges of CH2 so that the chassis may be pushed into the enclosure against the back. When the chassis has been pushed into the enclosure so that the back flange of the chassis is touching the back of the enclosure, the sides should be pushed together into their normal position.
  - c. ( ) Position the chassis within CH2 so that the two small holes in the rear of chassis flange are aligned with the corresponding holes in CH2. Place a #4 sheet metal screw through each hole in CH2 and secure to the chassis drawing up screws just to the point where they are seated. They will be tightened later. Use a little soap or oil on the self tapping screws.
  - d. ( ) Set the tuning capacitor (C1) at full mesh position (not against the pin stop but in position where the top edge of the rotor and stator plates are even.) Take care in succeeding operations not to disturb this setting.
  - e. ( ) Using a 1/4" x 6-32 screw, attach dial pointer D7 to the shaft of the tuning capacitor, the dial pointer being in the horizontal position (parallel to the top edge of the panel). Tighten the screw only moderately as the pointer position must be checked in a following step before final tightening. Be certain to center the pointer.
  - f. ( ) Place the aluminum dial shield plate (CH5) over the control shafts and place the plastic calibrated panel (CH6) on top of CH5. See Figure 6.
  - g. ( ) Install the four rubber feet in the bottom of CH1 (front panel, top and bottom) and place CH1 over CH2. Attach temporarily by means of two #4 screws at the rear center of both top and bottom. Draw up the screws just short of the point where they would seat (CH1 slightly loose permitting fore and aft movement).

- 5 h. ( ) Note that there are two dial pointer reference marks on the plastic calibrated panel. These horizontal marks should be in line with the pointer when the plastic panel is attached to the cabinet.
- i. ( ) Carefully align the holes in CH1, CH6, CH5 and CH2 (the four front #4 screws may be temporarily installed here to facilitate alignment, if desired). The pointer should be in line with the reference marks (if the pointer touches the plastic dial, carefully bend the pointer away from the panel - rotate the pointer to be sure that clearance is maintained around the full travel of the pointer). If the pointer is not aligned with the reference marks, reposition the pointer until it is aligned, taking care not to disturb the tuning capacitor setting. Tighten the pointer screw securely in aligned position.
- j. ( ) Complete the assembly of the cabinet and panels by placing the remaining sheet metal screws in the appropriate holes. Tighten all cabinet screws securely taking care not to strip the threads. Use a little soap or oil on the threads when tapping the first time.
- k. ( ) Install a knob on each of the shafts as follows: (the knob with the pointer goes on SW1, the right hand shaft): Slip a 1/4" I.D. flatwasher, a 1/4" I.D. wave washer, and another 1/4" I.D. flatwasher over each shaft. Push the knobs on the shafts and compress the wave washers until nearly flat. Then tighten the 8-32 setscrews securely. Be sure the pointer is correctly indexed.

## 6. TWO METER CALIBRATION

- a. ( ) The accuracy of the Viking 6N2 Meter VFO will be no better than that of the signal generator or source used to calibrate it. To fully utilize the stability and calibration capabilities of the VFO, the frequency standard or source used to calibrate it should have an accuracy of .005% or better. Most crystal standards or crystal calibrated variable frequency standards (such as the LM and BC-221 series) are satisfactory for normal calibration purposes if properly used and checked against WWV.

A crystal controlled transmitter or exciter may be used as a frequency calibration source but it must be remembered that crystal holder name plate frequencies usually are not exact due to oscillator circuit variations, aging, poor original calibration and other causes. This is particularly TRUE in overtone type oscillators. Do not use an 8 mc. crystal in an overtone oscillator to calibrate the VFO without accurately checking the exact frequency by other means.

- b. ( ) Two Meter Calibration: The frequency calibration source must have a moderate signal output, capable of being easily detected by the receiver which will be used for zero beat indication, at the following frequencies:

F1 Any frequency or subfrequency of the VFO dial markings between 144.0 and 144.3 megacycles which will fall within the range of the calibration receiver. Examples of frequency possibilities are 8000 KC or any of its harmonics such as 16, 24, 32, . . . . ., 144 megacycles.

F2 Any frequency or subfrequency of the VFO dial marking between 147.6 and 148.0 megacycles which fall within the range of the receiver.

<u>Dial Frequency</u>	<u>VFO Frequency</u>
144.0	8.0000
144.1	8.0055
144.2	8.0111
144.3	8.0166



6. b.

<u>Dial Frequency</u>	<u>VFO Frequency</u>
147.6	8.2000
147.7	8.2055
147.8	8.2111
147.9	8.2166
148.0	8.2222

Note: The VFO output frequency is multiplied 18 times to reach 2 meters.

It is recommended that 144.0 and 148.0 megacycles are used for calibration purposes.

A 100 kc crystal calibrator is an excellent generator source and will permit calibration at 8000 and 8200 kc.

Warm up the signal generator or other calibration source receiver, and 6N2 VFO for at least 1/2 hour before using it for VFO calibration.

- c. ( ) Set up a receiver capable of detecting each of the frequencies chosen in "b" above. Attach antenna leads to the receiver input and the signal generator output and bring the leads together until signal generator output can be picked up by the receiver with the beat frequency oscillator (BFO) on. Separate or shorten the leads as found necessary to keep the receiver from blocking due to excessive signal input.

Allow the receiver to warm up for approximately 1/2 hour with the BFO ON (to stabilize the local oscillator and BFO) and log the dial settings for frequencies F1 and F2. The BFO in the receiver may be used to log and compare the signal generator and VFO frequencies but it is desirable to obtain the final zero beat indication between VFO and signal generator signals without the BFO. Take care to avoid setting the receiver on image frequencies. Also allow the 6N2 Meter VFO to warm up for 1/2 hour.

- d. ( ) Set the signal generator on F2, the frequency chosen in "b" above, and tune the receiver to F2. Turn off the BFO in the receiver. Set the VFO dial accurately at F2.
- e. ( ) Tune trimmer capacitor C3 (see Figure 7 for location) so the VFO output signal is zero beat with the signal generator signal (as heard in the receiver).
- f. ( ) Set the signal generator on F1 (the frequency chosen in "b" above) and tune the receiver to F1. Turn off the BFO in the receiver and set the VFO dial at F1.
- g. ( ) Tune padder capacitor C2 (located directly above C3) so that the VFO signal is zero beat with the signal generator signal.
- h. ( ) Repeat steps "d" through "g" to reduce the effect of the interaction of C2 and C3 adjustments. This completes the Two Meter calibration.
- i. ( ) If zero beat cannot be obtained when adjusting C2 and C3, check the following:
- (1) Accuracy of frequency standard (crystals used in amateur service are often found to differ from their marked frequency, particularly when used in over-tone oscillators.)
  - (2) Make certain the image frequencies are not being mistaken for desired frequencies in the receiver.
  - (3) Make certain that tuning capacitor C1 and the dial pointer are correctly set (steps 5e and 5j).

6. i. (4) NOTE: The following is not normally required but is included for completeness. If, after the above steps have been taken, calibration is still not possible, tune the receiver (with the BFO on) until the VFO is heard. If the VFO signal is too high in frequency (with C2 and C3 at full mesh) push the turns of L1 together slightly and recalibrate. If the VFO signal is too low in frequency (with C2 and C3 unmeshed), the turns of L1 should be spread slightly and the unit recalibrated. In the back of the cabinet is a small hole through which the coil turns of L1 may be observed. In some cases, with care, it is possible to adjust the bottom turn of L1 and thus avoid disassembling the cabinet to adjust L1. A small, pointed plastic or wooden stick should be used to avoid damaging the wire insulation. If any difficulty is experienced in trying this adjustment, the unit should be disassembled.

Only a very small movement of a coil turn will be needed to adjust L1 so large increments are to be avoided.

## 7. TEMPERATURE COMPENSATION ADJUSTMENT

C23, which is a differential variable capacitor, together with C21 and C22 form an adjustable temperature compensating network. C23 was set at mid value during the Two Meter calibration and the temperature compensation will be approximately right.

However, if more exact temperature compensation is needed, the following step by step procedure should be followed:

### CAUTION:

The signal source used to compare the 6N2 VFO must be very stable. A 100KC crystal calibrator is suitable. Do not rely on a receiver's frequency stability, as many receivers drift more than this VFO. The receiver will be used only as a mixer and as such will not affect the accuracy of the measurements.

Warm up all equipment a minimum of one hour.

### PROCEDURE:

1. Warm-up a receiver capable of tuning 8.1 megacycles.
2. Warm-up the 100KC crystal calibrator.
3. Tune the receiver to 8.1 megacycles. This is best done by turning on the receiver BFO, and tuning the receiver to zero-beat against the 100KC crystal calibrator at 8.1 mc, and then turning off the BFO.
4. Apply power to the 6N2 VFO. Turn its bandswitch to the "144-148" position (fully clockwise).
5. Connect a short antenna lead to the receiver and couple the receiver to the 6N2 VFO by laying the antenna lead near the VFO power cord. Do not overload the receiver. (If the 100KC crystal calibrator is not built into the receiver it will have to be coupled to the receiver input also.)
6. Allow the 6N2 VFO to warm-up for 30 minutes.
7. Carefully zero-beat the VFO signal against the crystal calibrator signal.

7. 8. Allow about 10 minutes (or however much time is necessary) until the VFO has drifted an audible number of cycles. Then carefully re-zero beat the VFO being careful to note which direction the VFO must be turned to re-zero.
- 9a. If the frequency of the VFO increased (the VFO signal was lowered in frequency to re-zero) C23 should be turned slightly clockwise (less Negative Temperature Coefficient). See Figure 7. Then readjust C3 to reset the frequency if necessary.
- 9b. If the frequency of the VFO decreased (the VFO signal was raised in frequency to re-zero) C23 should be turned slightly counter-clockwise (more Negative Temperature Coefficient).
10. Repeat steps 8 and 9 as necessary.
11. Typical stability: After a 30 minute warm-up, drift of less than .001% per hour is typical.

## 8. SIX METER CALIBRATION

- a. ( ) The six meter calibration must be done after the two meter calibration is completed. The accuracy of the six meter dial depends on the accuracy of the two meter calibration.

The frequency calibration source must have a moderate signal output at the following frequencies:

F5 Any frequency or subfrequency of the VFO dial markings between 53.0 and 53.3 megacycles which fall within the range of the calibration receiver.

F4 Any frequency or subfrequency of the VFO dial markings between 51.5 and 51.8 megacycles which fall within the range of the receiver.

F3 Any frequency or subfrequency of the VFO dial markings between 50.0 and 50.3 megacycles which fall within the range of the receiver.

<u>Dial Frequency</u>	<u>VFO Frequency</u>
53.0 megacycles	8.8333 megacycles
53.1 "	8.8500 "
53.2 "	8.8166 "
53.3 "	8.8333 "
51.5 "	8.5833 "
51.6 "	8.6000 "
51.7 "	8.6166 "
51.8 "	8.6333 "
50.0 "	8.3333 "
50.1 "	8.3500 "
50.2 "	8.3666 "
50.3 "	8.3833 "

It is recommended that 53.1, 51.6 and 50.1 megacycles be used for F5, F4 and F3 respectively.

- b. ( ) Turn the VFO bandswitch (SW1 - right hand knob) to the 53 to 54 mc position. Set the signal generator on F5 and tune (zero beat) the receiver to F5. Turn OFF the receiver BFO. Set the VFO dial accurately at F5.



8. c. ( ) Tune the calibrating capacitor C11 (see Figure 7 for location) so that the VFO output signal is zero beat with the signal frequency calibration source (as heard in the receiver).
- d. ( ) Repeat steps b and c with the bandswitch turned to the 51.5 to 53 mc. position, the calibration signal at F4, and C10 tuned to F4.
- e. ( ) Repeat steps b and c with the bandswitch turned to the 50 to 51.5 mc. position (fully counter-clockwise), the calibration signal at F3 and C9 tuned to F3.
- f. ( ) Check all calibration points. Remember the Two meter calibration must be done first, then the high frequency band (53 to 54 mc.) on six meters, then the middle six meter band (51.5 to 53 mc.) and finally the low frequency band (50 to 51.5 mc.) on six meters. The three six meter bands are interdependent. The six meter calibration depends on the two meter calibration, the reverse is not true. (i.e., two meter calibration is not affected by six meter adjustments).

## 9. OPERATION

- a. ( ) The Viking 6N2 Meter VFO has been designed as a crystal substitute. Since the majority of transmitters employ 8 mc. crystals the VFO operates on 8 mc. so that minimum modification of the existing oscillator or transmitter circuitry will be required.
- b. ( ) The cathode of the VFO is carried through the power cable and P1 so that remote control may be used. As B+ voltage is normally applied to the VFO, merely grounding the VFO cathode return will energize the VFO for either transmitting or VFO "zeroing" purposes.
- c. ( ) Figures A, B and C, on the following page, show three of the most popular overtone crystal oscillator circuits. The dashed lines indicate the wiring changes necessary to use the VFO. When driven by the VFO, the normal crystal oscillator stage serves as a frequency multiplier (usually a tripler.) The circuit in Figure A can frequently be operated with the VFO by merely grounding the side of the crystal holder which is connected to the feedback winding. Some retuning of the tuned circuit may be required. Use of the switch permits switching from crystal to VFO operation with a single crystal holder.

Figure D is a typical pentode cathode-feedback oscillator such as is used in the Johnson 6N2. Notice that it is necessary in this (as in any crystal oscillator) to remove the feedback so the crystal stage does not act as a self excited oscillator. This is done in the 6N2 by the Crystal-VFO Switch which shorts out the choke in the cathode of the 6U8 (see Figure D).

- d. ( ) When the crystal oscillator circuit has been modified, plug in the VFO and with both equipments operating (6.3 volts filament and 250-300 volts B+ on the VFO) set the VFO at 8.100 kc. (145.8 mc. on the dial). Tune C20 (Screwdriver control at bottom center of cabinet rear) for maximum drive to transmitter. The output of the VFO is quite uniform throughout the frequency range and C20 need not be readjusted to cover this range.

It should be observed that the output circuit of the VFO is tuned to 8.1 megacycles with C20. This tuned circuit includes the RG-59/U cable capacity and the input capacity of the normal crystal oscillator grid circuit (usually about 25 to 32 mmfd.). C20 provides a reasonably wide range of adjustment but in some cases it may be necessary that either addition external capacity be added across C20, or L3 replaced. If the maximum drive to the transmitter (at 8.1 mc.) is obtained with C20 turned all the way



9. d. in, add 10 to 15 mmfd. of fixed capacity across C20. If C20 is turned all the way out, remove L3 (3.3 uhy coil) and replace it with the following coil: A 3.3 microhenry coil (equivalent to L3) may be made by closewinding 27 turns of #28 enamel covered copper wire around a 15,000 ohm 2 watt resistor (5/16" by 11/16" size 2 watt resistor). A 26 turn coil will be about 3.2 uhy. Remove one turn at a time from L3 until C20 tunes at about 2 turns from maximum capacity.
- e. ( ) Operation with the Johnson 6N2 transmitter requires only that P1 be plugged into the back of the 6N2, the crystal - VFO switch turned to "VFO" and C20 on the 6N2 VFO peaked at 8100 kc (145.8 mc. on the dial).

Tune up the 6N2 (in TUNE position) for Maximum grid drive. The Oscillator will normally dip and the Multiplier may dip or peak (the important thing is maximum Grid current). The transmitter circuits may have to be retuned when large changes in frequency are made.

- f. ( ) Early model 6N2's may need a minor modification. See Figure D. If your 6N2 has a R25 (15,000 ohm 1/2 watt resistor) wired between pin 12 of SW1 and ground, remove it. Install a new R25 (56 ohm 1/2 watt resistor - see Figure D) as follows: Cut the leads to 1/2". Disconnect the long green lead which is connected to pin 2 of the 6U8 socket. Connect R25 to pin 2 of the 6U8 socket (Solder). Shorten the green lead 1 inch and connect it to the remaining lead of R25 (Solder).
- g. ( ) Zeroing into a receiver may be done by turning the 6N2 Operate switch to TUNE. Depending on the particular station setup the signal strength for zero beating may have to be reduced in the receiver by turning the RF gain control down and/or turning on the AVC. If the receiver is not well shielded, the strength may be excessive and make zeroing difficult. Do not confuse audio stage rectification in the receiver. (see the ARRL handbook for cure) with overloading of the receiver. A little ingenuity used in individual cases (where receiver zeroing is desired) can overcome possible overloading.
- h. ( ) Careful use of the Viking 6N2 Meter VFO will result in a stable unit which will provide good service. A 20 minute or greater warmup is recommended before operation near a band edge.

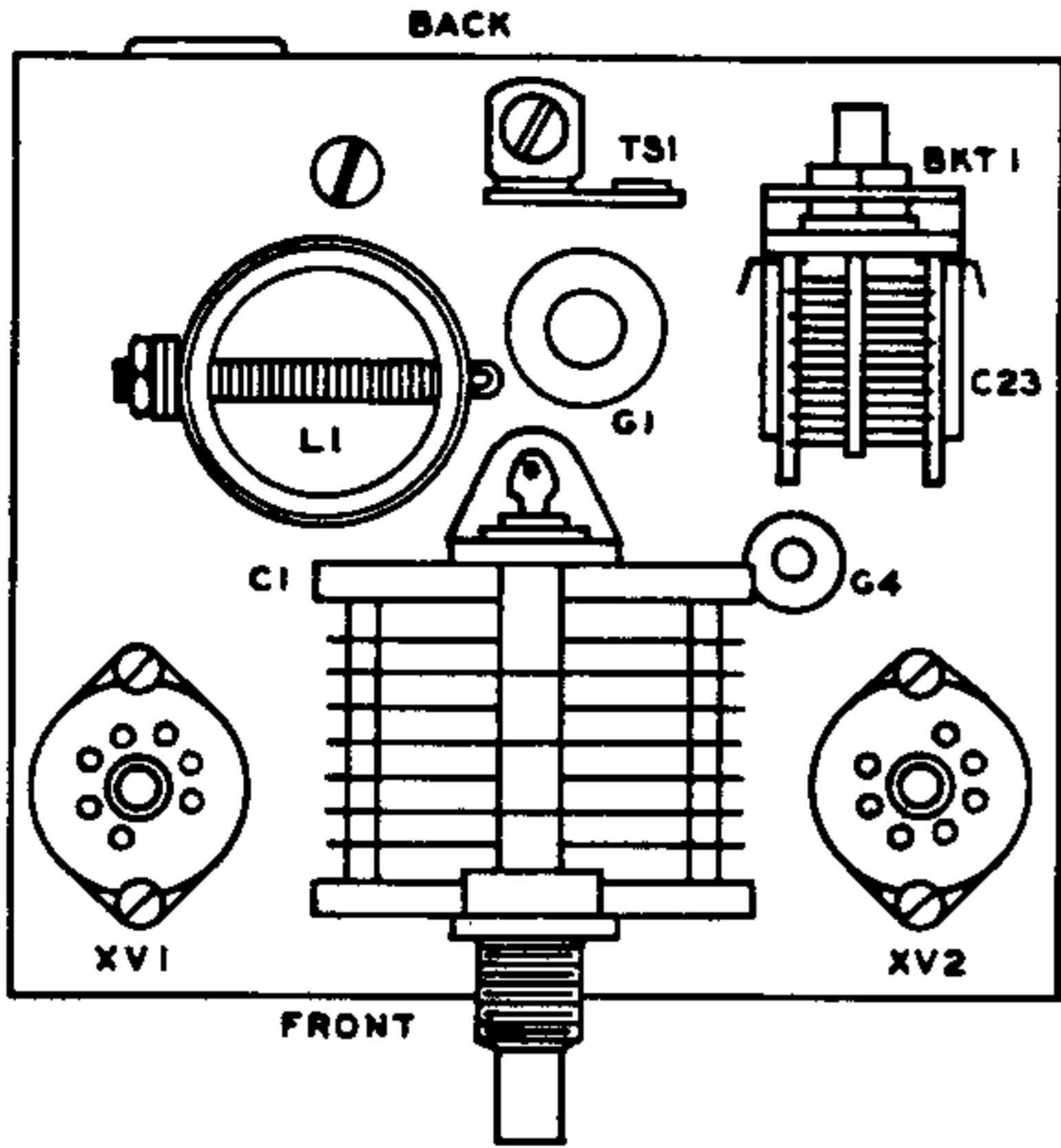

CHASSIS-TOP VIEW  
FIGURE 1A

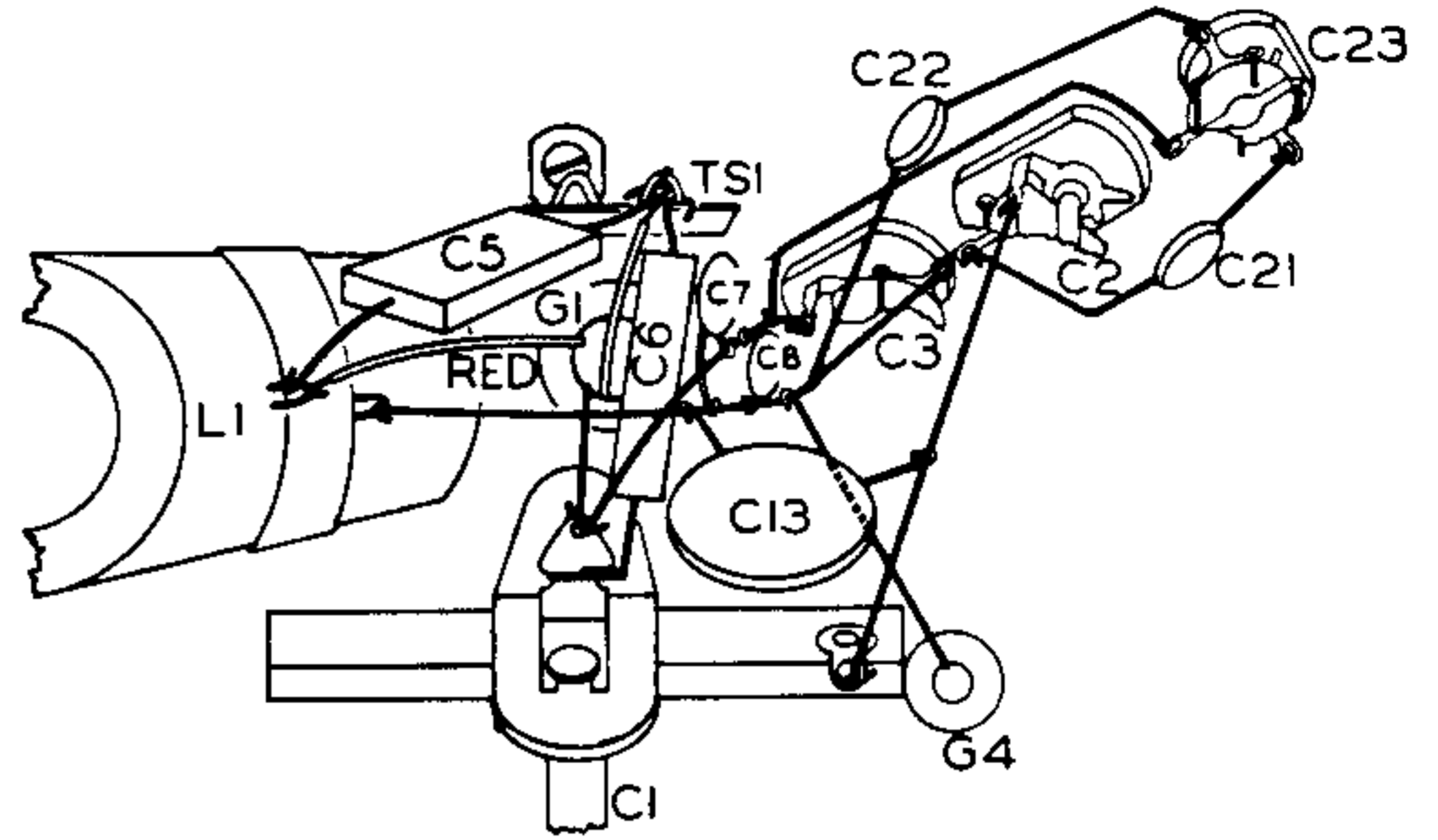

TOP VIEW-WIRING DETAIL  
FIGURE 1B

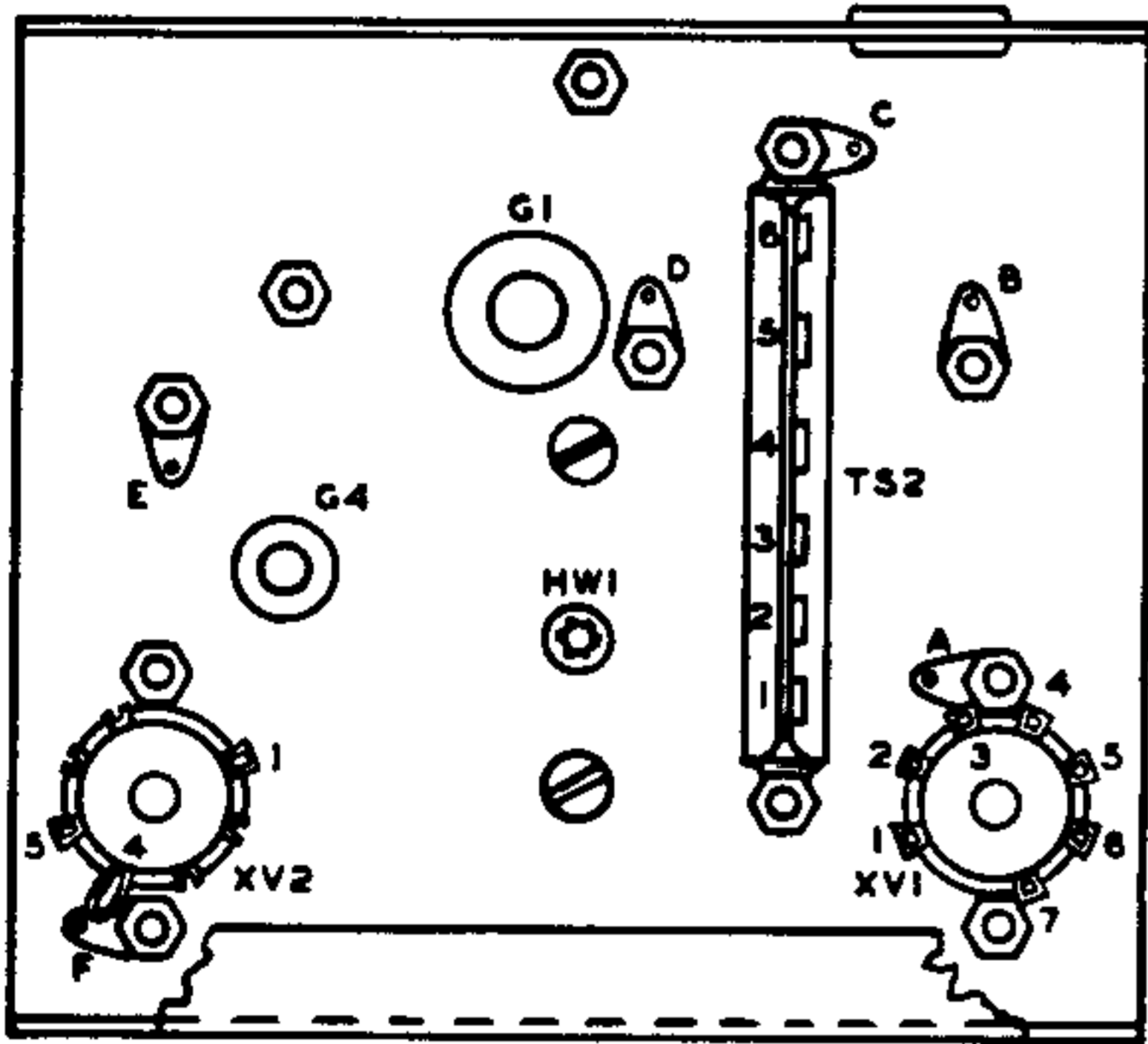

CHASSIS-BOTTOM VIEW  
FIGURE 2A

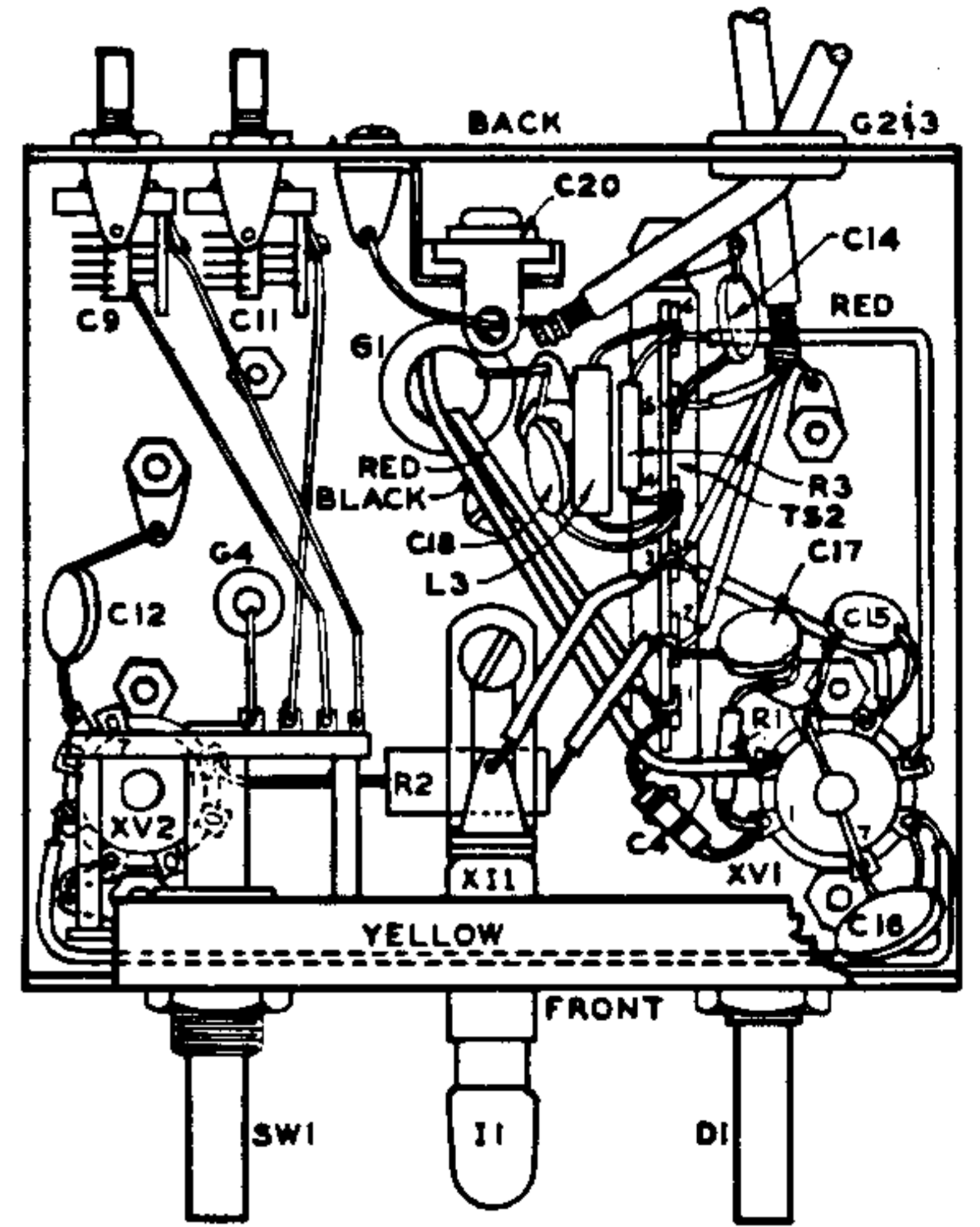

CHASSIS-BOTTOM VIEW  
FIGURE 2B

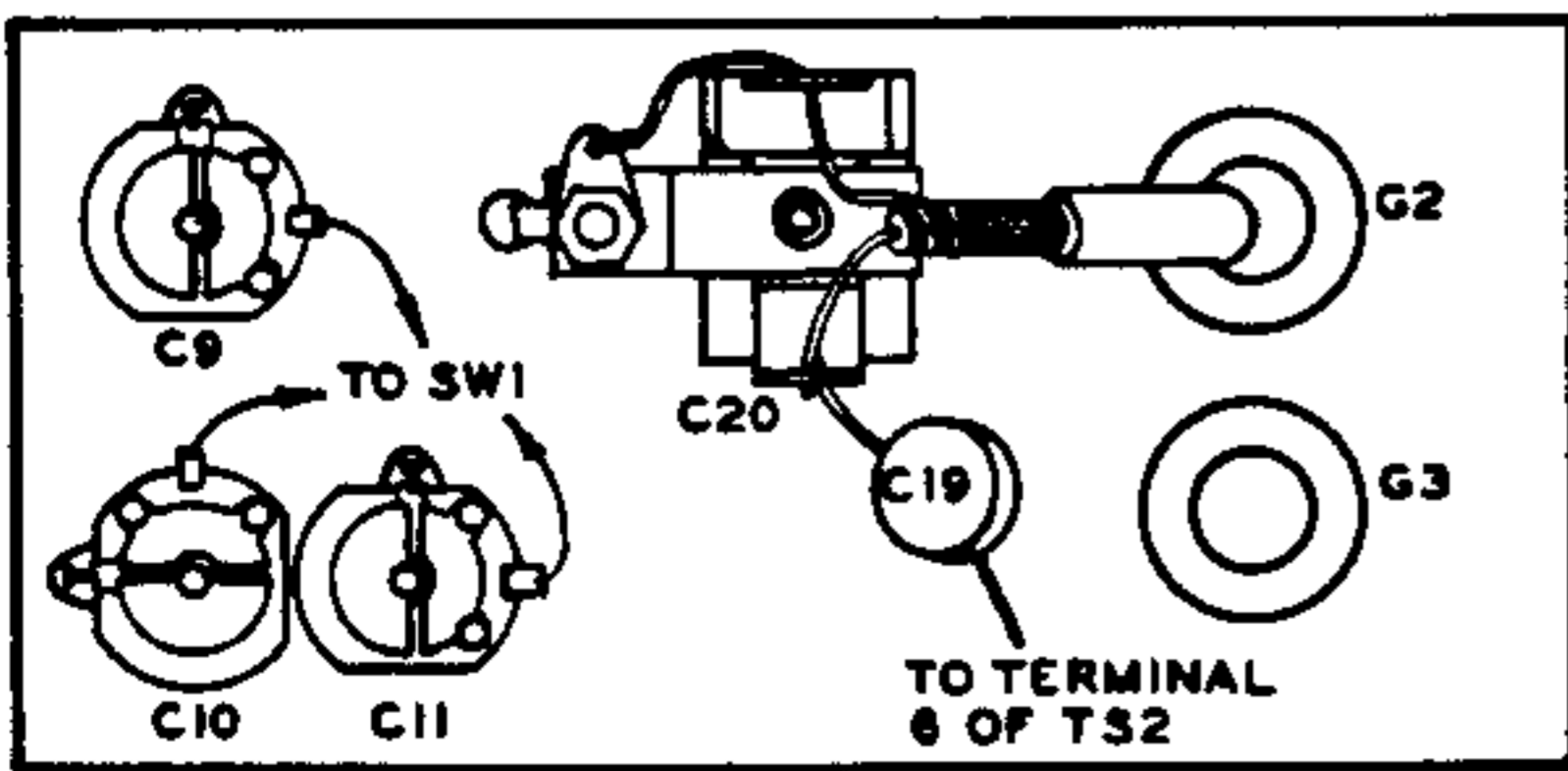

BACK VIEW (INSIDE)  
FIGURE 3A

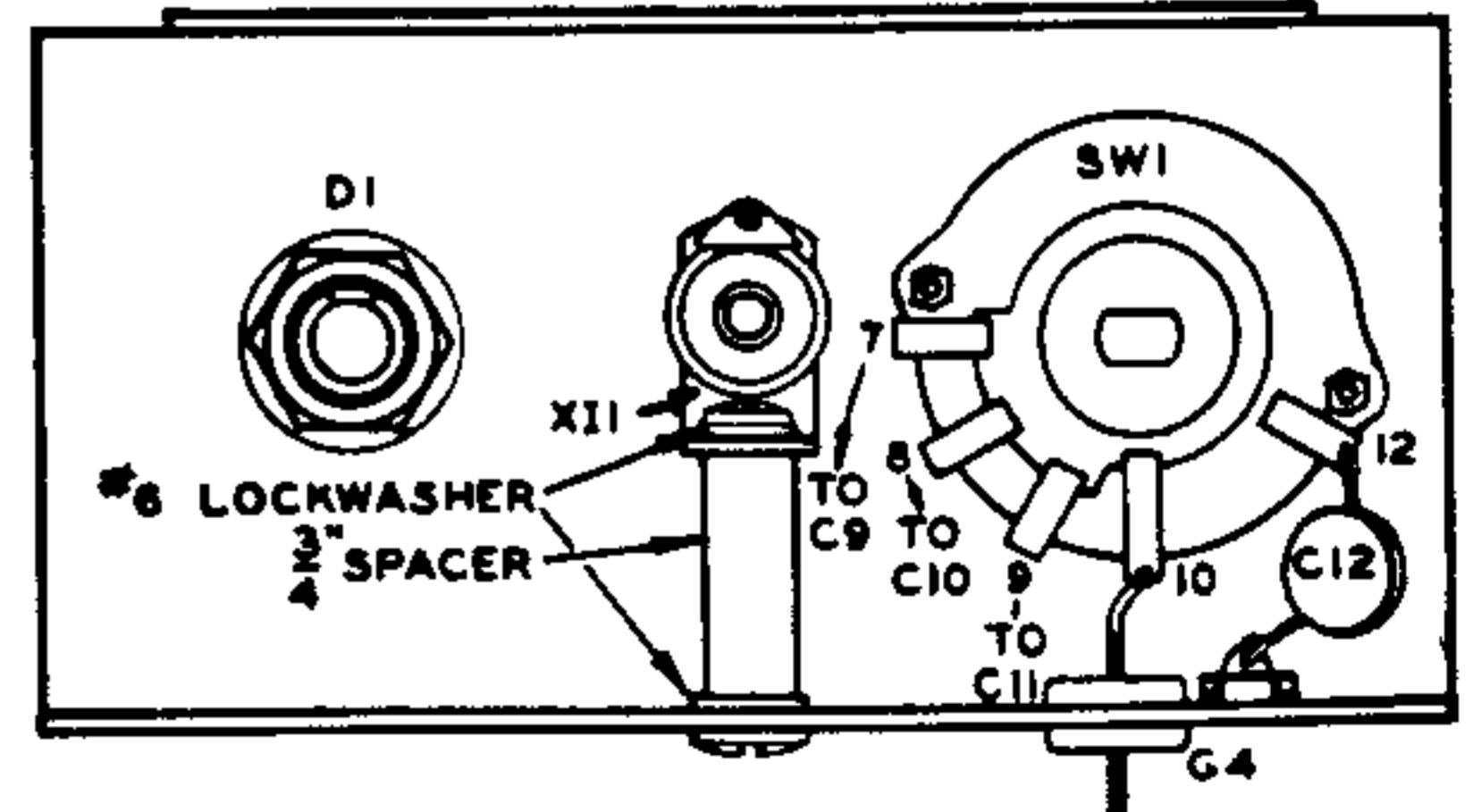

FRONT VIEW (INSIDE)  
FIGURE 3B

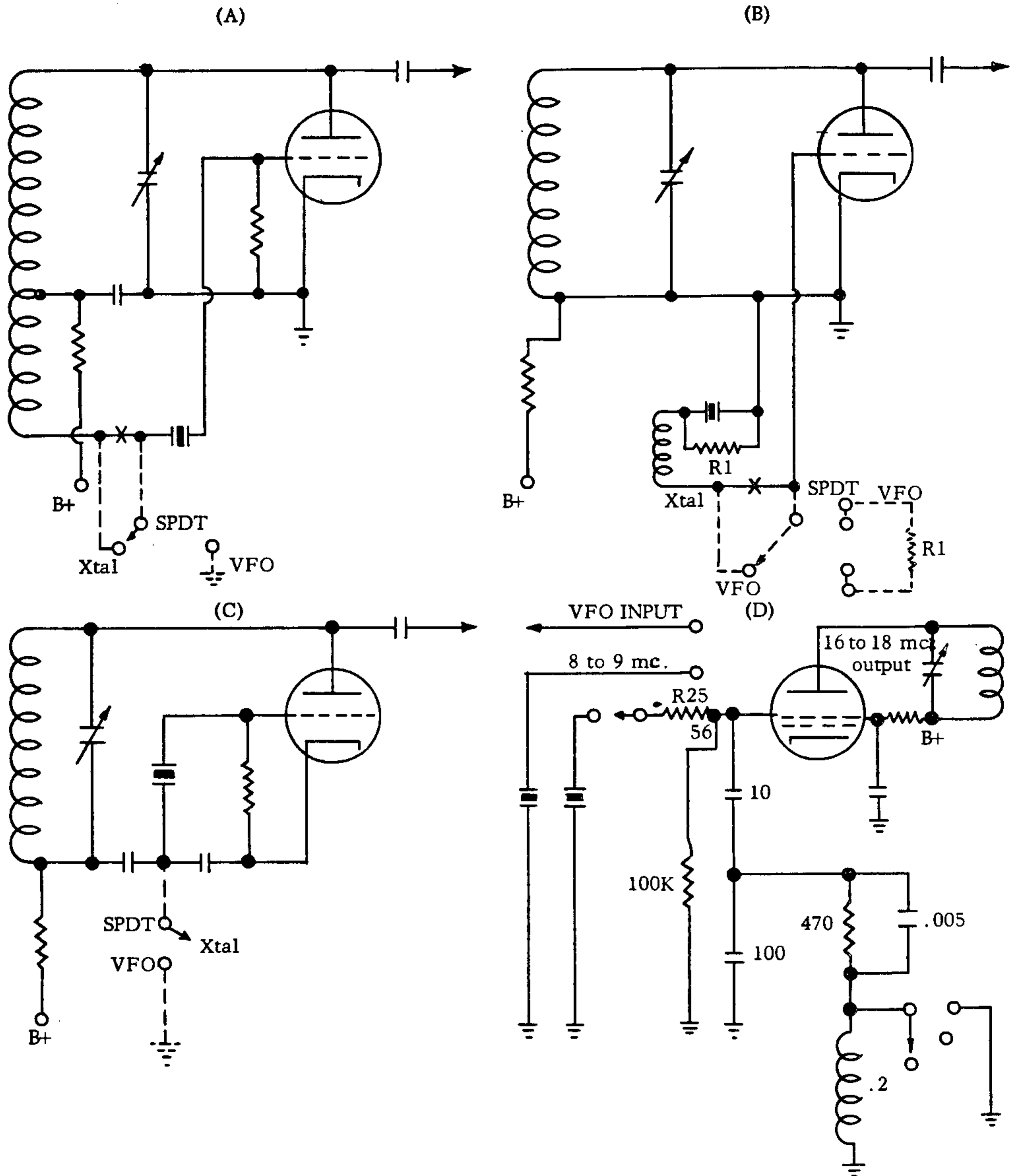

TYPICAL CRYSTAL OSCILLATOR CIRCUITS

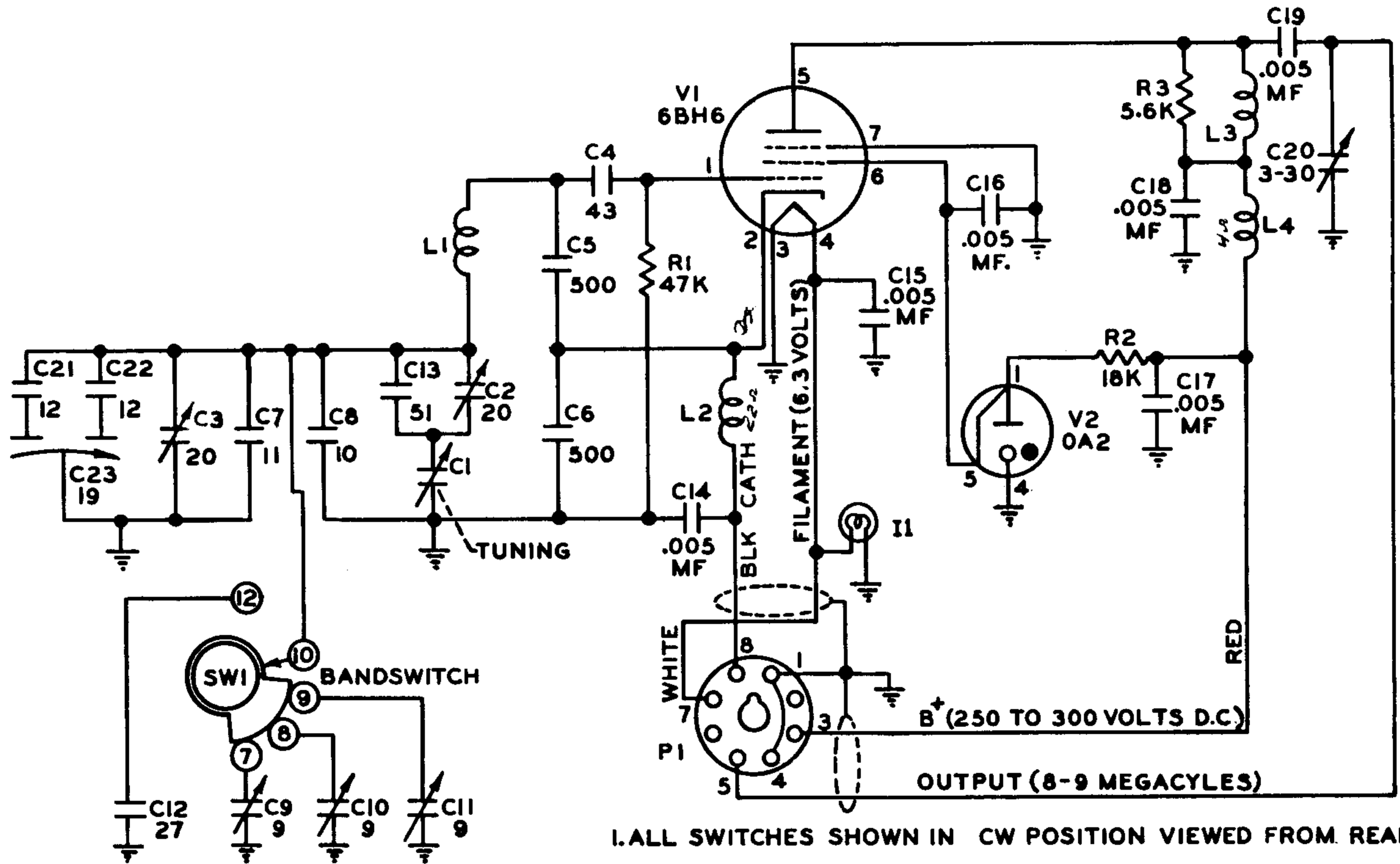

VIKING 6N2 METER VFO SCHEMATIC



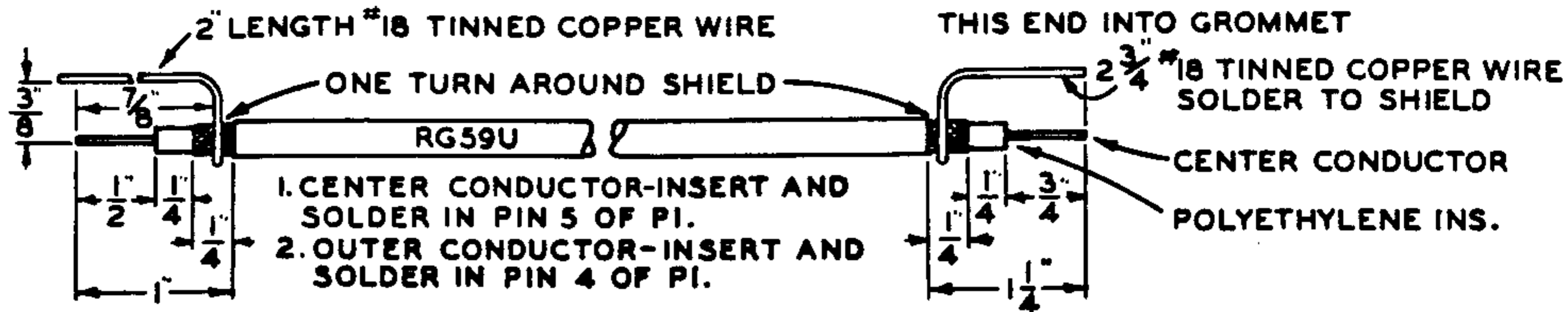

COAXIAL CABLE  
FIGURE 4

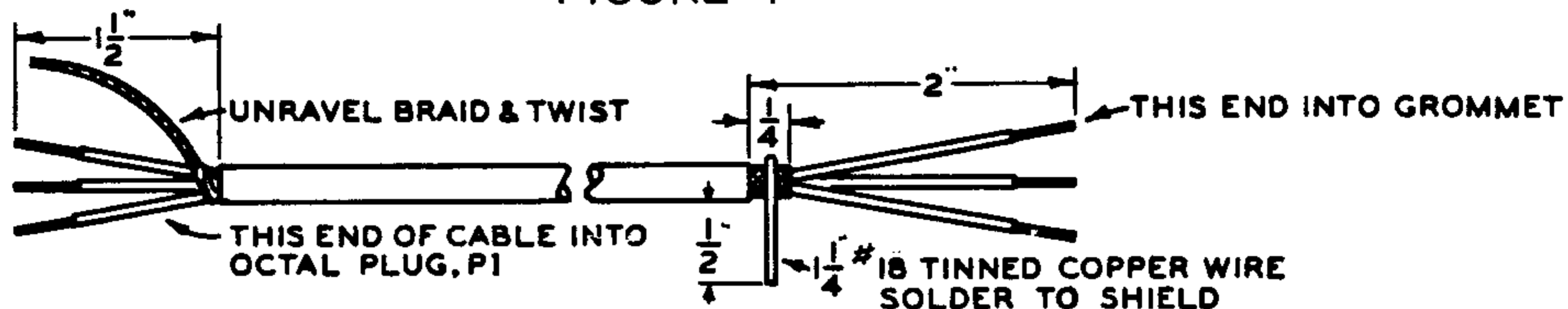

1. WHITE,  $1\frac{1}{4}$ " LENGTH, INSERT & SOLDER PIN 7 OF PI
2. WH-BLK,  $1\frac{1}{4}$ " LENGTH, INSERT & SOLDER PIN 8 OF PI
3. WH-RED,  $1\frac{1}{4}$ " LENGTH, INSERT & SOLDER PIN 3 OF PI
4. SHIELD,  $1\frac{1}{4}$ " LENGTH, INSERT & SOLDER PIN 1 OF PI
5. STRIP & TIN  $\frac{5}{8}$ " ON THE THREE COLORED LEADS

1. WHITE,  $1\frac{1}{2}$ " LENGTH
2. WH-BLK,  $1\frac{1}{2}$ " LENGTH
3. WH-RED,  $1\frac{1}{2}$ " LENGTH
4. STRIP & TIN  $\frac{5}{16}$ " ON END OF ALL THREE LEADS

3 CONDUCTOR SHIELDED CABLE  
FIGURE 5

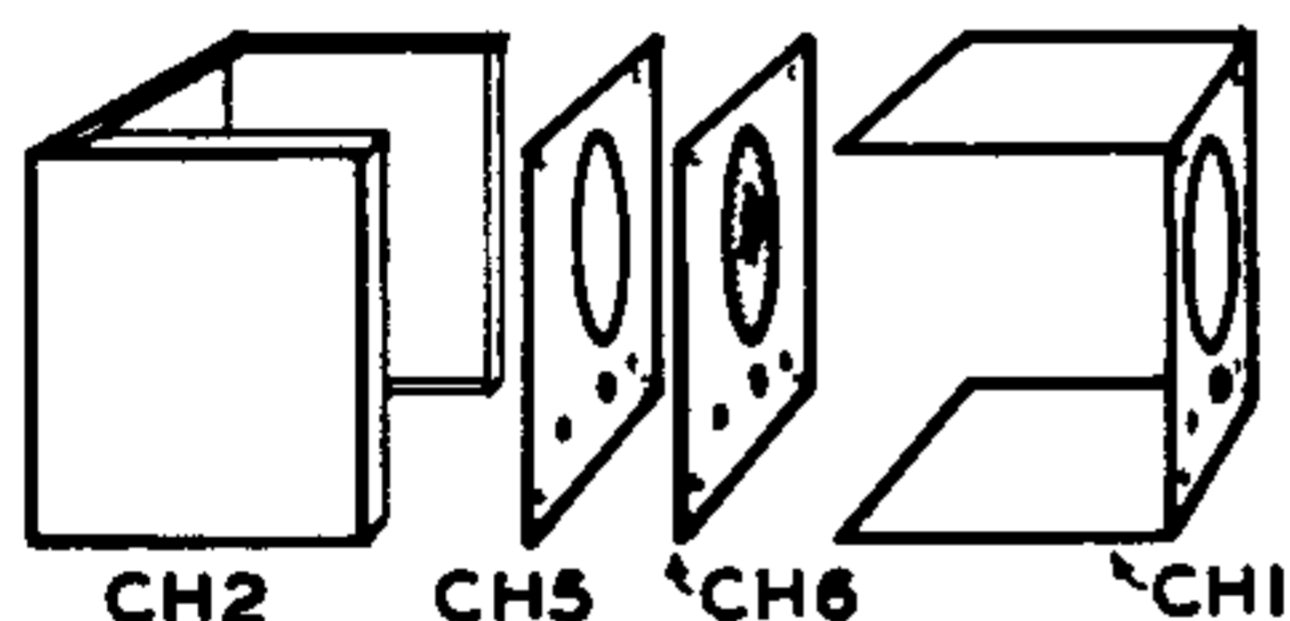

CABINET ASSEMBLY  
FIGURE 6

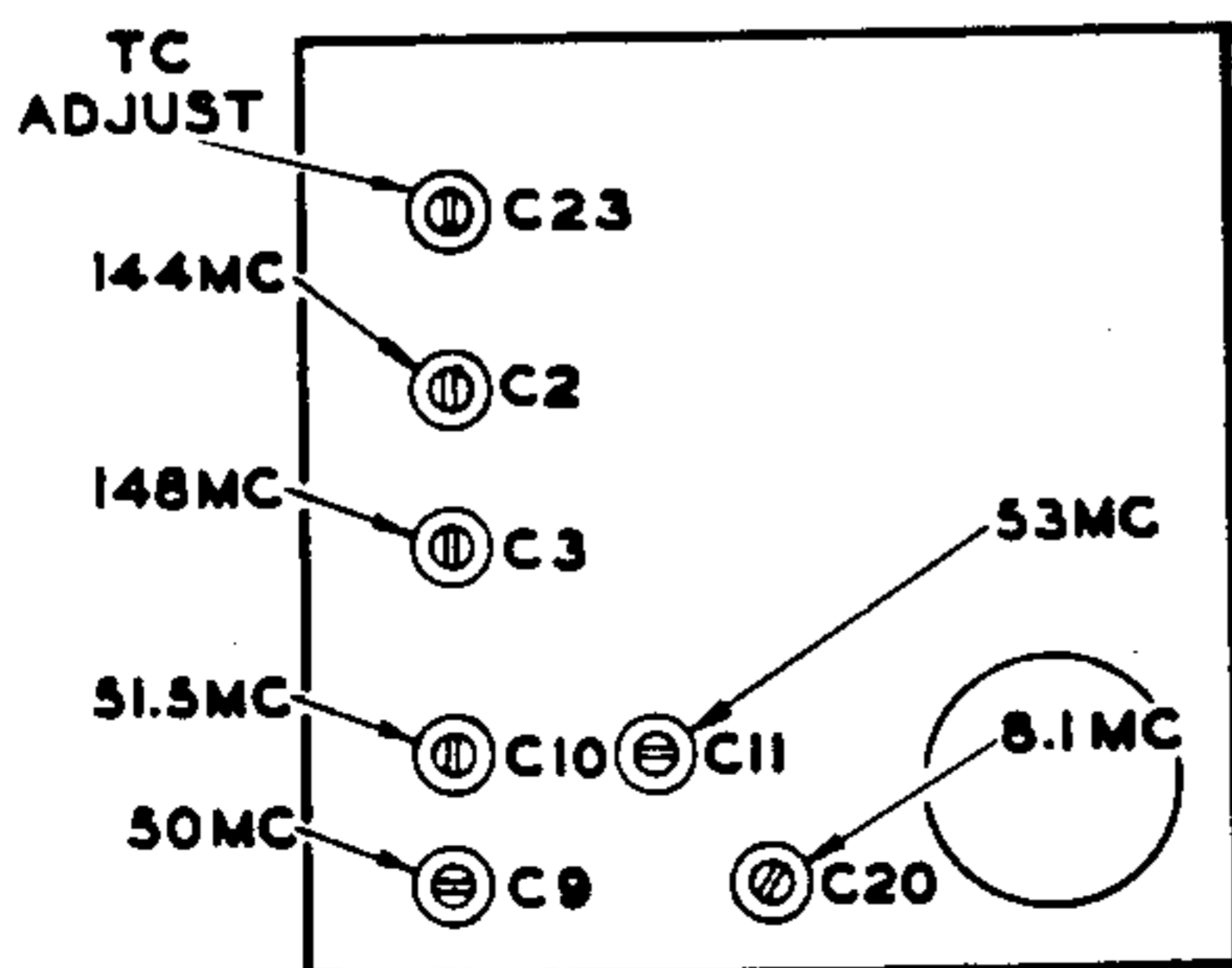

TRIMMER LOCATION  
FIGURE 7

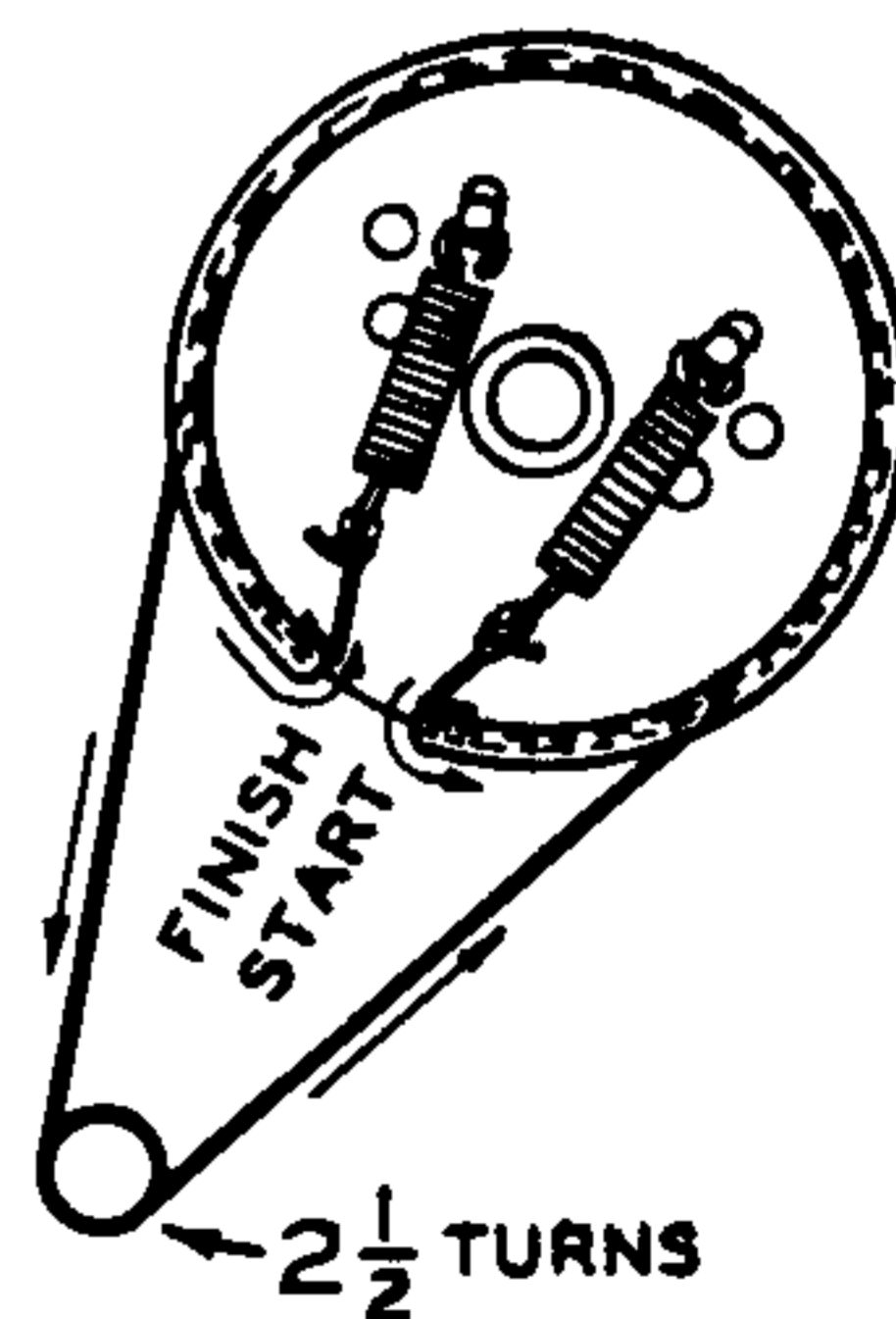

DIAL CORD STRINGING  
FIGURE 8