

Data Sheet

1082 Test Gauge

FEATURES

- MircoSpan™ adjustment eases span calibration
- Mirror-band dial and knife-edge pointer eliminates parallax error while assuring easy readability of precise measurements
- Teflon® coated, SS movement
- Accuracy complies with $\pm 0.25\%$ of span (ASME B40.1 Grade 3A)
- Externally adjustable dial

TYPICAL USES

- Test Benches
- Specialized OEM Equipment
- Test and Measurement & Validation
- Calibration Labs



1082
4½", 6", 6½" dial sizes

SPECIFICATIONS

Accuracy:	$\pm 0.25\%$ of span (ASME B40.100 Grade 3A)
Ranges:	Vacuum, Compound to 10,000 psi
Sizes:	4½", 6" or 8½"
Process Connection Location:	Lower or Back
Process Connection:	¼ NPT Male or ½ NPT Male
Dial:	Externally adjustable aluminum, black numerals with polished mirror band
Case Style:	Solid front
Movement:	400 Series SS rotary design, Teflon® S coated bearings, micrometer span adjustment, bimetallic temp. compensator (0.005%/per °F Max. temperature error)
Pointer:	Black painted aluminum with red-painted, knife edge tip
Mounting Options:	Stem or flush
Weather Protection:	Case not sealed, recommended for weather protected environment only
Approvals:	CRN

WETTED COMPONENTS

Bourdon Tube	Process Connection	Joints
Bronze	Brass	Silver Brazed
Monel®	Monel®	Welded

NON-WETTED COMPONENTS

Case	Ring	Window
Aluminum, solid front, black epoxy coated	Hinged steel, black wrinkle finish	Glass

Temperature Compensated Movement

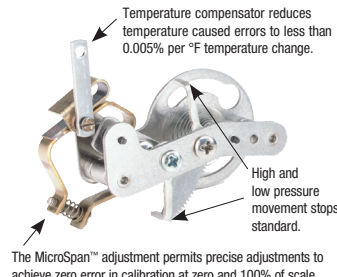

Externally Adjustable Dial

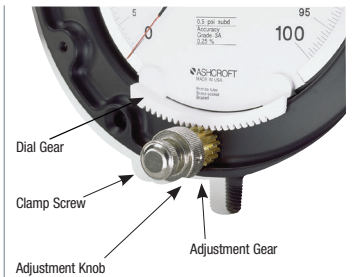

KEY BENEFITS

- Temperature-compensated movement significantly reduces temperature error
- Rugged SS construction
- Compact design

MIN/MAX TEMPERATURE LIMITS

Version	Ambient	Process	Storage
Dry	-20°F to 200°F (-29°C to 93°C)	-20°F to 250°F (-29°C to 121°C)	-40°F to 250°F (-40°C to 121°C)

Data Sheet

1082 Test Gauge

ORDERING CODE	Example:	45	1082	P	S	02	L	100#	-XPD
Dial Size									
45 - 4½" dial		45							
60 - 6" dial									
85 - 8½" dial									
Model									
1082 - Test gauge			1082						
System									
A - Bronze tube and brass socket									
P - Monel [®] tube and socket				P					
Case Style									
S - Solid front					S				
Process Connection Size									
02 - ¼ NPT Male						02			
04 - ½ NPT Male									
Process Connection Location									
L - Lower							L		
B - Back									
Ranges									
15# - 0-15 psi									
30# - 0-30 psi									
60# - 0-60 psi									
100# - 0-100 psi								100#	
160# - 0-160 psi									
200# - 0-200 psi									
300# - 0-300 psi									
400# - 0-400 psi									
600# - 0-600 psi									
1000# - 0-10,000 psi									
Options (If choosing an option(s) must include an "X")									
PD - Acrylic window									-X_ PD
SD - Safety Glass window									
TS - Throttling devices									
AY - Aluminum case, threaded ring (N/A with adj. dial, Lower connection only)									
TY - Phenolic case, threaded ring (N/A with adj. dial, Lower connection only)									

Data Sheet

1082 Test Gauge

STANDARD RANGES				
	Range		Graduations	
	psi	inHg	Figure Interval	Minor Graduations
Vacuum	-	30/0 inHg	2 inHg	0.1 inHg
	0/15	-	1	0.05
Positive Pressure	0/30	-	2	0.1
	0/60	-	5	0.2
	0/100	-	5	0.5
	0/150	-	10	0.5
	0/200	-	10	1
	0/300	-	20	1
	0/400	-	20	2
	0/600	-	50	2
	0/800	-	50	5
	0/1000 ⁽¹⁾	-	50	5
	0/1500	-	100	5
	0/2000	-	100	10
	0/3000	-	200	10
	0/5000	-	500	10
	0/10,000	-	1000	50

(1) Max. range Model 1383

STANDARD RANGES			
	Range		
	Bar	kPa	kg/cm ²
Vacuum	-1/0	-100/0	-1/0
	-1/0/1.5	-100/0/150	-1/0/1.5
Compound	-1/0/3	-100/0/300	-1/0/3
	-1/0/5	-100/0/500	-1/0/5
	-1/0/9	-100/0/900	-1/0/9
	0/4	0/400	0/4
Positive Pressure	0/6	0/600	0/6
	0/1	0/100	0/1
	0/1.6	0/160	0/1.6
	0/2.5	0/250	0/2.5
	0/4	0/400	0/4
	0/6	0/600	0/6
	0/10	0/1000	0/10
	0/16	0/1600	0/16
	0/25	0/2500	0/25
	0/40	0/4000	0/40
	0/60 ⁽¹⁾	0/6000	0/60
	0/100	0/10,000	0/100
	0/160	0/16,000	0/160
	0/250	0/25,000	0/250
	0/400	0/40,000	0/400
0/600	0/60,000	0/600	

COMPOUND RANGES			
	inHg/psi		
	Compound	30/0/15	30/0/20
30/0/30		30/0/20	5/0/1
30/0/60		30/0/20	2/0/1
30/0/100		30/0/10	2/0/1
30/0/150		10/0/5	1/0/0.5
30/0/200		10/0/5	1/0/0.5
30/0/300		10/0/5	0.5/0/0.2
30/0/400		5/0/2	0.5/0/0.1

Data Sheet

1082 Test Gauge

DIMENSIONS in [] are millimeters

For reference only, consult Ashcroft for specific dimensional drawings

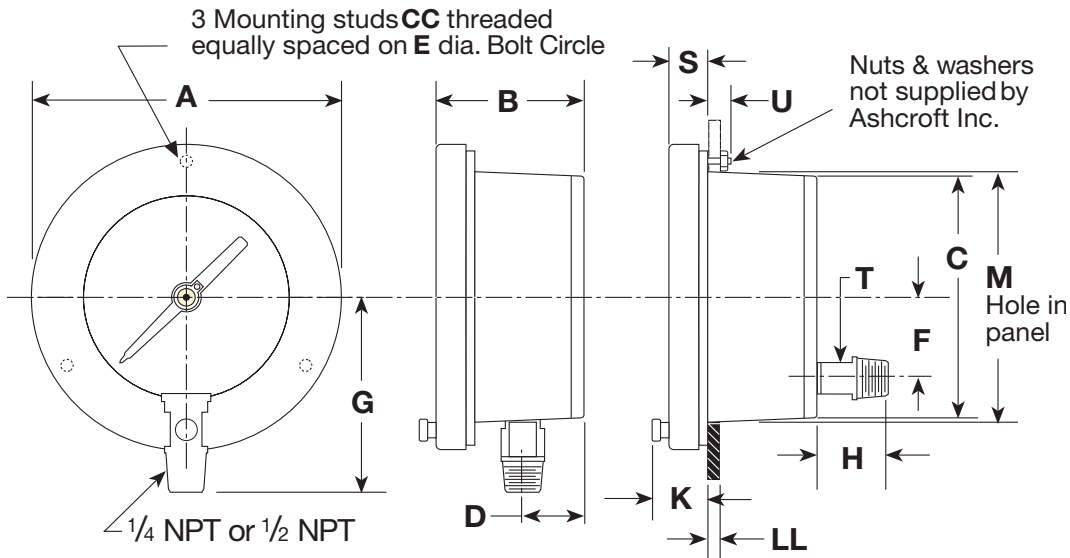

Dial Size (inches)	A	B	C	CC	D	E	F	G	H	K	LL	M	S	T	U
4 1/2	6 3/32 [155]	2 7/8 [73]	4 3/4 [121]	#10-24	1 3/16 [30]	5 3/8 [137]	1 5/8 [41]	4 7/8 [100]	1 3/8 [35]	1 1/32 [34]		4 7/8 [124]		5/8 [16]	3/4 [19]
6	7 9/16 [192]	2 7/8 [73]	4 3/4 [121]	1/4-20	1 3/16 [30]	7 [178]	1 5/8 [41]	4 1/2 [114]	1 3/8 [35]	1 1/32 [34]	1/8 to 1/2 [3 to 13]	6 1/2 [165]	5/8 [16]	5/8 [16]	3/4 [19]
8 1/2	10 1/16 [257]	2 7/8 [73]	4 3/4 [121]	1/4-20	1/4-20	9 5/8 [244]	1 5/8 [41]	6 [152]	1 3/8 [35]	1 1/32 [34]		9 [229]		5/8 [16]	3/4 [19]