

# DEVELOPMENT PROCESS MANUAL

CITY OF ALBUQUERQUE

# TABLE OF CONTENTS

<b>CHAPTER 1 OVERVIEW.....</b>	<b>20</b>
Article 1-1 The Development Process Manual (DPM) Introduction.....	20
Article 1-2 Purpose of the DPM .....	22
Article 1-3 Relationship to Other Regulatory Documents .....	23
Part. 1-3(A) Integrated development ordinance (IDO) .....	23
Part. 1-3(B) Standard Specifications .....	23
Section. 1-3(B)(1) New Mexico Standard Specifications for Public Works Construction, Current Edition.....	23
Part. 1-3(C) Contract Documents for City -Wide Utilities and Cash Paving, current edition.....	23
Part. 1-3(D) Standard Details .....	24
Part. 1-3(E) Reference Lists and Other Applicable Design Manuals and Resources	24
Part. 1-3(F) Abbreviations .....	24
Article 1-4 DPM Update Procedure .....	26
Part. 1-4(A) User Comments.....	26
Part. 1-4(B) Committees Responsible for Review of Administrative Changes .....	26
Section. 1-4(B)(1) DPM Executive Committee.....	26
Section. 1-4(B)(2) DPM Subcommittees .....	27
Part. 1-4(C) Procedure for Changing the Administrative Rules.....	27
Part. 1-4(D) Notification of Proposed Rule Changes.....	28
Part. 1-4(E) Emergency Effective Date .....	28
Part. 1-4(F) Appeals.....	29
<b>CHAPTER 2 DEVELOPMENT PROCEDURES.....</b>	<b>30</b>
Article 2-1 Determining the Appropriate Procedure.....	9
Article 2-2 Subdivision of Land .....	14
Part. 2-2(A) Governing Regulations.....	14
Part. 2-2(B) Standard Subdivision Procedure .....	14
Section. 2-2(B)(1) Applicability.....	14
Section. 2-2(B)(2) Required Application Materials.....	14
Part. 2-2(C) Non-Compliant Parcel Procedure.....	15
Section. 2-2(C)(1) Applicability.....	15
Section. 2-2(C)(2) Procedures.....	15
Part. 2-2(D) Bulk Land Subdivision Variance Criteria.....	16
Section. 2-2(D)(1) Applicability .....	16
Section. 2-2(D)(2) Bulk Land Subdivision Variance Criteria.....	16
Section. 2-2(D)(3) Bulk Land Subdivision Variance Procedure.....	16
Article 2-3 Public Infrastructure Improvement Procedures.....	17
Part. 2-3(A) Governing regulations .....	17
Part. 2-3(B) Infrastructure Design Development Procedure .....	18
Section. 2-3(B)(1) Applicability .....	18
Section. 2-3(B)(2) Procedure.....	18
Part. 2-3(C) Construction Agreements (Infrastructure Improvements Agreement - IIA) .....	23

Section. 2-3(C)(1) "Procedure a".....23  
 Section. 2-3(C)(2) "Procedure B".....24  
 Section. 2-3(C)(3) "Procedure C" .....27  
 Part. 2-3(D) Work Order(s) .....28  
     Section. 2-3(D)(1) Applicability .....28  
     Section. 2-3(D)(2) Procedures .....28  
 Article 2-4 Private Infrastructure Improvements ..... 39  
     Part. 2-4(A) Applicability .....39  
     Part. 2-4(B) Private Facilities in Public Right-Of-Way.....40  
     Part. 2-4(C) Procedural differences.....40  
         Section. 2-4(C)(1) Private Infrastructure Design Development.....40  
         Section. 2-4(C)(2) Construction of Private Infrastructure .....41  
 Article 2-5 Commercial, Public, Multi-Family Building Permits..... 42  
     Part. 2-5(A) Applicability.....42  
     Part. 2-5(B) Governing Regulations .....42  
     Part. 2-5(C) Procedure .....42  
         Section. 2-5(C)(1) Preliminary Plan Check Services .....42  
         Section. 2-5(C)(2) Plan Preparation .....43  
         Section. 2-5(C)(3) Application for Plan Check.....44  
         Section. 2-5(C)(4) Plan Check .....44  
         Section. 2-5(C)(5) Building Permit Issuance.....44  
         Section. 2-5(C)(6) Construction Inspections .....45  
         Section. 2-5(C)(7) Certificate of Occupancy .....45  
 Article 2-6 Related Building Permits ..... 47  
     Part. 2-6(A) Demolition Permits.....51  
         Section. 2-6(A)(1) Applicability .....51  
         Section. 2-6(A)(2) Procedures.....51  
     Part. 2-6(B) Floodplain Development Permit.....52  
         Section. 2-6(B)(1) Applicability .....52  
         Section. 2-6(B)(2) Procedures.....52  
     Part. 2-6(C) Foundation Only Permits.....53  
         Section. 2-6(C)(1) Applicability.....53  
         Section. 2-6(C)(2) Procedures .....53  
     Part. 2-6(D) Grading Permit and Paving Permit .....54  
         Section. 2-6(D)(1) Applicability.....54  
         Section. 2-6(D)(2) Procedure .....54  
     Part. 2-6(E) Plumbing and Electrical Permits .....55  
         Section. 2-6(E)(1) Applicability.....55  
         Section. 2-6(E)(2) Procedures.....55  
     Part. 2-6(F) Relocation of Existing Buildings Permits.....55  
         Section. 2-6(F)(1) Applicability.....55  
         Section. 2-6(F)(2) Procedures.....56  
     Part. 2-6(G) Sign Permits.....56  
         Section. 2-6(G)(1) Applicability.....56  
         Section. 2-6(G)(2) Procedures .....57  
     Part. 2-6(H) Wall, Fence, and Retaining wall Permits .....57  
         Section. 2-6(H)(1) Applicability.....57  
         Section. 2-6(H)(2) Procedures .....58  
 Article 2-7 Other Construction Permits ..... 59  
     Part. 2-7(A) Air Contaminant Sources Registration.....59  
         Section. 2-7(A)(1) Applicability .....59  
         Section. 2-7(A)(2) Procedure .....59  
     Part. 2-7(B) Authority-To-Construct Permit .....59  
         Section. 2-7(B)(1) Applicability.....59

Section. 2-7(B)(2) Procedure.....60

Part. 2-7(C) Barricade Permit.....60

Section. 2-7(C)(1) Applicability.....60

Section. 2-7(C)(2) Procedure.....60

Part. 2-7(D) Blasting Permit.....61

Section. 2-7(D)(1) Applicability.....61

Section. 2-7(D)(2) Procedure.....61

Part. 2-7(E) Encroachment Agreement (Approval To Place Private Infrastructure In A Public Easement).....61

Section. 2-7(E)(1) Applicability.....61

Section. 2-7(E)(2) Procedure.....61

Part. 2-7(F) Excavation Permit.....61

Section. 2-7(F)(1) Applicability.....61

Section. 2-7(F)(2) Procedure.....62

Part. 2-7(G) Integrated Development Ordinance Approvals.....62

Section. 2-7(G)(1) Applicability.....62

Section. 2-7(G)(2) Procedure.....62

Part. 2-7(H) Median Cuts and Left Turn Lane Approval.....63

Section. 2-7(H)(1) Applicability.....63

Section. 2-7(H)(2) Procedure.....63

Section. 2-7(H)(3) Additional approvals.....63

Part. 2-7(I) Oversize, Overweight and/or Over Length Truckloads Permit.....64

Section. 2-7(I)(1) Applicability.....64

Section. 2-7(I)(2) Procedure.....64

Part. 2-7(J) PERMIT SO-19 (Private Storm Drain Facilities within A City Right-Of-Way And/or Easement).....64

Section. 2-7(J)(1) Applicability.....64

Section. 2-7(J)(2) Procedures.....64

Part. 2-7(K) Private Use of Fire Hydrants.....65

Section. 2-7(K)(1) Applicability.....65

Section. 2-7(K)(2) Procedure.....65

Section. 2-7(K)(3) Fire Hydrant Special Use Permit, refer to the [AB-CWUA's Water and Sewer Rate Ordinance](#).....66

Part. 2-7(L) Public Swimming Pool Operating Permit.....66

Section. 2-7(L)(1) Applicability.....66

Section. 2-7(L)(2) Procedure.....66

Part. 2-7(M) Revocable Contract (Approval To Place Private Infrastructure In The Public Right-Of-Way).....67

Section. 2-7(M)(1) Applicability.....67

Section. 2-7(M)(2) Procedure.....67

Part. 2-7(N) Sewer Tapping Permit.....68

Section. 2-7(N)(1) Applicability.....68

Section. 2-7(N)(2) Procedure.....68

Part. 2-7(O) Sidewalk, Drive Pad and Curb and Gutter Permits.....68

Section. 2-7(O)(1) Applicability.....68

Section. 2-7(O)(2) Procedure.....68

Part. 2-7(P) Solar Rights Permit.....69

Section. 2-7(P)(1) Applicability.....69

Section. 2-7(P)(2) Procedure.....69

Part. 2-7(Q) Stormwater Control Permit for Erosion and Sediment Control.....70

Section. 2-7(Q)(1) Applicability.....70

Section. 2-7(Q)(2) Procedure.....70

Part. 2-7(R) Surface Disturbance Permit.....70

Section. 2-7(R)(1) Applicability.....70

Section. 2-7(R)(2) Procedure.....71  
 Part. 2-7(S) Water Meter and Fire Line Application.....71  
     Section. 2-7(S)(1) Applicability.....71  
     Section. 2-7(S)(2) Procedure.....71  
 Article 2-8 Drainage and Transportation Submittals.....72  
     Part. 2-8(A) Drainage and Transportation Submittal Approval Procedures .....72  
     Part. 2-8(B) Drainage Facilities and Roadway Improvements Construction Agree-  
         ment and Financial Guarantee.....73  
     Part. 2-8(C) Forms and Certificates.....73  
 Article 2-9 DPM Variances .....74  
     Part. 2-9(A) Variance to DPM Standards.....74  
         Section. 2-9(A)(1) Applicability .....74  
         Section. 2-9(A)(2) Procedure .....74  
     Part. 2-9(B) Sidewalk Variance or Waiver .....75  
         Section. 2-9(B)(1) Applicability:.....75  
     Part. 2-9(C) Temporary Sidewalk Deferral.....77  
         Section. 2-9(C)(1) Applicability.....77  
         Section. 2-9(C)(2) Governing Regulations:.....77  
         Section. 2-9(C)(3) Procedure.....77  
         Section. 2-9(C)(4) Stub Street/ Cul-de-Sac Variance.....78  
         Section. 2-9(C)(5) Vacation Of Right-Of-Way Or Easement.....79

**CHAPTER 3 IMPACT FEES REGULATIONS ..... 81**

Article 3-1 Administrative Organization and Responsibility..... 84  
     Part. 3-1(A) Impact Fees Administrator.....84  
     Part. 3-1(B) Other Departments.....85  
 Article 3-2 Imposition of Impact Fee ..... 85  
     Part. 3-2(A) Fee Payer.....85  
     Part. 3-2(B) Determination and Assessment of the Impact Fee.....86  
         Section. 3-2(B)(1) General. ....86  
         Section. 3-2(B)(2) Assessment of Fee.....86  
     Part. 3-2(C) Collection of Impact Fee.....86  
         Section. 3-2(C)(1) General.....86  
         Section. 3-2(C)(2) Invalid Payment .....86  
         Section. 3-2(C)(3) Credits Prior to Completion .....87  
     Part. 3-2(D) Expiration of Building Permits.....87  
     Part. 3-2(E) Private Security.....88  
     Part. 3-2(F) Private Fire Protection or Rescue .....88  
 Article 3-3 Determination of an Impact Fee Based On Fee Schedules ..... 88  
     Part. 3-3(A) Payment from Schedule .....88  
     Part. 3-3(B) Residential Heated Area.....89  
     Part. 3-3(C) Gross Floor Area .....89  
     Part. 3-3(D) Mixed Use Development.....89  
     Part. 3-3(E) Mixed Use Structures .....89  
     Part. 3-3(F) Shell Permit.....89  
     Part. 3-3(G) Change of Use .....90  
     Part. 3-3(H) Accessory or Auxiliary Uses .....90  
     Part. 3-3(I) House Moves and Mobile Home Moves .....91  
     Part. 3-3(J) Mobile Home/Recreational Vehicles (RVs) Parks.....91  
     Part. 3-3(K) Model Homes .....91  
     Part. 3-3(L) Remodeling and Redevelopment.....91  
     Part. 3-3(M) Miscellaneous Land Use Types .....91  
 Article 3-4 Independent Fee Determination ..... 92  
     Part. 3-4(A) Option of the Fee payer .....92



Part. 3-4(B) Notice of Intent by Fee payer .....92  
Part. 3-4(C) Pre-Application Meeting .....92  
Part. 3-4(D) Guidelines.....92  
Part. 3-4(E) Sufficiency Determination.....93  
Part. 3-4(F) Determination of Impact Fee .....94  
Part. 3-4(G) Effective Date.....94  
Part. 3-4(H) Application for Permit.....94  
Article 3-5 Collection and Deposit of the Impact Fee ..... 95  
    Part. 3-5(A) Road (Transportation) Impact Fee .....95  
        Section. 3-5(A)(1) Service Areas .....95  
        Section. 3-5(A)(2) Deposit of the Impact Fee.....95  
    Part. 3-5(B) Drainage (Stormwater) Impact Fees.....95  
        Section. 3-5(B)(1) Service Areas.....95  
        Section. 3-5(B)(2) Deposit of the Impact Fee .....95  
    Part. 3-5(C) Park, Open Space and/or Trails Impact Fees.....95  
        Section. 3-5(C)(1) Service Areas .....95  
        Section. 3-5(C)(2) Deposit of the Impact Fee.....96  
    Part. 3-5(D) Fire and Police Impact Fees.....96  
        Section. 3-5(D)(1) Service Areas.....96  
        Section. 3-5(D)(2) Deposit of the Impact Fee.....96  
Article 3-6 Use of Impact Fee Funds ..... 97  
    Part. 3-6(A) Purpose.....97  
    Part. 3-6(B) System Improvements.....97  
Article 3-7 Refunds ..... 98  
    Part. 3-7(A) Refund for Failure to Construct or Provide Service.....98  
    Part. 3-7(B) Overpayment.....98  
    Part. 3-7(C) Underpayment.....98  
Article 3-8 Exemptions ..... 99  
    Part. 3-8(A) Must Be Claimed by Fee Payers .....99  
    Part. 3-8(B) Total Exemptions .....99  
    Part. 3-8(C) Exemption Based on Error or Misrepresentation.....99  
Article 3-9 Credits..... 100  
    Part. 3-9(A) General Conditions.....100  
    Part. 3-9(B) General Documentation and Procedures.....100  
        Section. 3-9(B)(1) Amount of Credit Requested.....101  
        Section. 3-9(B)(2) Documentation.....101  
        Section. 3-9(B)(3) Submittals for Construction Credits .....101  
        Section. 3-9(B)(4) City Approved Work Order.....101  
        Section. 3-9(B)(5) Change Orders.....102  
        Section. 3-9(B)(6) Acceptance of Construction for Credit.....102  
        Section. 3-9(B)(7) Acceptance of Land Dedication for Credit .....103  
        Section. 3-9(B)(8) Transferability of Credits. ....103  
        Section. 3-9(B)(9) Withdrawal of Offer by Applicant.....104  
        Section. 3-9(B)(10) Value of Credits.....104  
    Part. 3-9(C) Excess Credits .....104  
Article 3-10 Exemptions ..... 105  
    Part. 3-10(A) Affordable Housing.....105  
        Section. 3-10(A)(1) Ownership Housing.....105  
        Section. 3-10(A)(2) Rental Housing.....106  
    Part. 3-10(B) Development in Metropolitan Redevelopment Areas .....107  
Article 3-11 Amendments..... 107

**CHAPTER 4 CONSTRUCTION PLAN STANDARDS..... 108**

Article 4-1 General Plan Information ..... 111

    Part. 4-1(A) General Plan Information ..... 111

    Part. 4-1(B) CAD Software..... 111

    Part. 4-1(C) Plan Submittals ..... 111

        Section. 4-1(C)(1) Project Development Stage (30%, 60%, 95%, 100%)  
111

        Section. 4-1(C)(2) Final Plan Submittal (For City of Albuquerque Proj-  
ects)..... 112

        Section. 4-1(C)(3) Plan Revisions ..... 112

Article 4-2 Plan Sheet Organization..... 113

    Part. 4-2(A) File Accuracy (units)..... 113

    Part. 4-2(B) Sheet Sizes..... 113

    Part. 4-2(C) Sheet Borders ..... 113

    Part. 4-2(D) Plan Sheet Assembly..... 113

    Part. 4-2(E) Construction Document Arrangement..... 113

Article 4-3 Graphic Standards..... 114

    Part. 4-3(A) Plan Scales..... 114

    Part. 4-3(B) Line Weights ..... 114

    Part. 4-3(C) Line Types/Styles..... 115

    Part. 4-3(D) Screening..... 115

    Part. 4-3(E) Text Styles and Fonts..... 115

    Part. 4-3(F) General Text Placement ..... 115

    Part. 4-3(G) Drawing Callouts..... 116

    Part. 4-3(H) Keyed Notes..... 116

    Part. 4-3(I) Bar Scales..... 116

    Part. 4-3(J) Dimensioning..... 116

    Part. 4-3(K) Legend..... 116

    Part. 4-3(L) North Arrow ..... 116

Article 4-4 DRAFTING PRACTICES ..... 117

    Part. 4-4(A) Drawing Layout..... 117

        Section. 4-4(A)(1) Title Blocks..... 117

        Section. 4-4(A)(2) View Orientation ..... 117

    Part. 4-4(B) Required Notation and Topography..... 118

        Section. 4-4(B)(1) Coordinate Systems ..... 118

        Section. 4-4(B)(2) Directional Indicators..... 118

        Section. 4-4(B)(3) Benchmarks ..... 118

        Section. 4-4(B)(4) Symbols..... 119

        Section. 4-4(B)(5) Right-of-Way..... 119

        Section. 4-4(B)(6) Utilities..... 119

        Section. 4-4(B)(7) Existing Features ..... 119

    Part. 4-4(C) Cross Referencing Between Drawings..... 121

        Section. 4-4(C)(1) Section and Detail References..... 121

        Section. 4-4(C)(2) Project Phasing, Bid Lots, or Bid Alternatives (For City  
Projects Only)..... 121

Article 4-5 PLAN SHEET CONTENT..... 122

    Part. 4-5(A) Title or Cover Sheet..... 122

    Part. 4-5(B) Index of Sheets/Key Map..... 123

        Section. 4-5(B)(1) Index of Sheets..... 123

        Section. 4-5(B)(2) Key Map..... 123

    Part. 4-5(C) General Notes/Legend Sheet..... 123

        Section. 4-5(C)(1) General Notes..... 123

        Section. 4-5(C)(2) Legend ..... 124

Part. 4-5(D) Summary of Quantities Sheet (Applicable to City of Albuquerque Projects Only) .....124

Part. 4-5(E) Survey Control Sheet .....124

Part. 4-5(F) Horizontal Layout Sheet.....124

Part. 4-5(G) Removals Sheet .....125

Part. 4-5(H) Plat Sheet .....125

Part. 4-5(I) Approved Grading and Drainage Plan .....125

Part. 4-5(J) Erosion Control Plan .....126

Part. 4-5(K) Master Street Plan.....126

Part. 4-5(L) Typical Sections Sheet.....126

Part. 4-5(M) Environmental Sheet .....127

Part. 4-5(N) Roadway Plans .....127

Section. 4-5(N)(1) Stationing.....127

Section. 4-5(N)(2) Horizontal Curve and Line Data for Left and Right Curb .....127

Section. 4-5(N)(3) Right-of-Way.....128

Section. 4-5(N)(4) Sheet References.....128

Section. 4-5(N)(5) Profiles and Grades.....128

Section. 4-5(N)(6) Driveway Information/Details.....129

Part. 4-5(O) Geometric Details/Special Details.....130

Section. 4-5(O)(1) Geometric Details.....130

Section. 4-5(O)(2) Specific Details .....130

Part. 4-5(P) Construction Traffic Control Details (Applicable to City of Albuquerque Projects).....130

Part. 4-5(Q) Signing and Striping Details/Layout Sheets.....131

Section. 4-5(Q)(1) General .....131

Section. 4-5(Q)(2) Signage .....132

Section. 4-5(Q)(3) Striping.....132

Section. 4-5(Q)(4) Plan Symbol Coding.....132

Part. 4-5(R) Traffic Signalization Details/Design Sheets.....133

Section. 4-5(R)(1) Traffic Signal General Notes & Legend.....133

Section. 4-5(R)(2) Equipment & Incidental items, Interconnect Requirements.....133

Section. 4-5(R)(3) Traffic Signal Estimated Quantities.....133

Section. 4-5(R)(4) Traffic Signal Plan.....134

Section. 4-5(R)(5) Street "A" & Street "B" Traffic Signal Cables & Conduits- I.....134

Section. 4-5(R)(6) Street "A" & Street "B" Traffic Signal Cables & Conduits- II.....134

Section. 4-5(R)(7) Traffic Signal Blocks.....134

Part. 4-5(S) Lighting Details/Design Sheets .....134

Part. 4-5(T) Roadway Cross Sections .....135

Part. 4-5(U) Drainage Details .....135

Section. 4-5(U)(1) Utilities.....135

Section. 4-5(U)(2) Right-of-Way.....136

Section. 4-5(U)(3) Sheet References.....136

Section. 4-5(U)(4) Storm Drainage and Profile Drawings .....136

Section. 4-5(U)(5) Catch Basins and Connector Pipe Information..137

Section. 4-5(U)(6) Utility Crossings.....137

Section. 4-5(U)(7) Stand Alone Drainage Plans .....137

Section. 4-5(U)(8) Channel Plans .....137

Section. 4-5(U)(9) Channel Cross Sections .....138

Part. 4-5(V) Utility Sheets .....139



Section. 4-5(V)(1) Master Utility Plan (Water, Sewer and Storm Drain)  
139

Section. 4-5(V)(2) Water Lines .....139

Section. 4-5(V)(3) Sanitary Sewer .....141

Article 4-6 RECORD DRAWING CRITERIA ..... 143

Part. 4-6(A) General Criteria .....143

Part. 4-6(B) Digital Record Criteria .....144

**CHAPTER 5 RECORDABLE AND DEVELOPMENT DOCUMENTS ..... 146**

Governing Regulations..... 148

Article 5-1 General Requirements for all Plats ..... 148

Part. 5-1(A) Nature and Purpose of Plat.....148

Part. 5-1(B) Title of Plat.....149

Part. 5-1(C) Date of Plat.....149

Part. 5-1(D) Location Map / Zone Atlas Map Number.....149

Part. 5-1(E) Scale and North Arrow.....149

Part. 5-1(F) Plat Boundary Lines.....149

Part. 5-1(G) Tie to Permanent Survey Monuments.....149

Part. 5-1(H) Existing Easements.....150

Part. 5-1(I) Existing Public Right-of-Way.....150

Part. 5-1(J) Total Area of Plat.....150

Part. 5-1(K) Monument Description and Location.....150

Part. 5-1(L) Special Flood Hazard Areas.....150

Article 5-2 Preliminary Plat Requirements..... 150

Part. 5-2(A) Scale.....151

Part. 5-2(B) Proposed Monumentation.....151

Part. 5-2(C) Existing Conditions.....151

Part. 5-2(D) Proposal Elements.....152

Article 5-3 Final Plat Detailed Requirements..... 152

Part. 5-3(A) Scale.....152

Part. 5-3(B) Monuments.....152

Section. 5-3(B)(1) Subdivision Control Monuments .....152

Section. 5-3(B)(2) Permanent Survey Monuments .....153

Section. 5-3(B)(3) Bench Marks.....153

Section. 5-3(B)(4) Existing Monumentation.....153

Part. 5-3(C) Plat Boundary.....153

Part. 5-3(D) Plat Area .....153

Part. 5-3(E) Reference to Federal Rectangular System.....153

Part. 5-3(F) Interior Data .....154

Part. 5-3(G) Exterior Data.....154

Part. 5-3(H) Subdivision Data .....155

Part. 5-3(I) Metes and Bounds Description / Legal Description.....155

Part. 5-3(J) Consent and Dedication Statements.....155

Part. 5-3(K) Certifications.....156

Article 5-4 GRANT OF DRAINAGE EASEMENT ..... 158

Article 5-5 Drainage Covenants ..... 158

Article 5-6 Graphic standards ..... 159

Part. 5-6(A) Materials.....159

Part. 5-6(B) Drafting Standards.....159

Article 5-7 Acceptable forms of language ..... 159

Section. 5-7(B)(1) Free Consent and Dedication .....160

Section. 5-7(B)(2) Surveyor's Certification .....161

Section. 5-7(B)(3) Sample Signature Block for Plats.....161

**CHAPTER 6 DRAINAGE, FLOOD CONTROL AND EROSION CONTROL**  
**163**

Article 6-2 Governing Regulations ..... 171

Article 6-3 Hydrology ..... 172

    Part. 6-3(A) Procedure for 40 Acre and Smaller Basins.....172

        Section. 6-3(A)(1) Precipitation Zones .....172

        Section. 6-3(A)(2) Land Treatments .....176

        Section. 6-3(A)(3) Abstractions.....177

        Section. 6-3(A)(4) Excess Precipitation & Volumetric Runoff .....177

        Section. 6-3(A)(5) Peak Discharge Rate for Small Watersheds.....180

        Section. 6-3(A)(6) Use of Rational Method for Watersheds Larger than  
40 Acres.....181

        Section. 6-3(A)(7) Hydrograph for Small Watershed.....183

    Part. 6-3(B) Time of Concentration, Lag Time, and Time to Peak.....183

        Section. 6-3(B)(1) Definitions.....184

        Section. 6-3(B)(2) Computation of Time of Concentration.....184

        Section. 6-3(B)(3) Computation of NRCS Lag Time.....186

        Section. 6-3(B)(4) Computation of Time to Peak.....186

        Section. 6-3(B)(5) Time of Concentration for Steep Slopes and Natural  
Channels .....188

        Section. 6-3(B)(6) Channel Routing for Steep Slopes and Natural  
Channels.....190

    Part. 6-3(C) Procedure for Small and Large Watersheds .....191

        Section. 6-3(C)(1) Computer Program .....191

        Section. 6-3(C)(2) Zones.....191

        Section. 6-3(C)(3) Design Storm.....191

    Part. 6-3(D) Symbols and Bibliography.....192

        Section. 6-3(D)(1) Definitions of Symbols.....192

        Section. 6-3(D)(2) Bibliography.....194

Article 6-4 Site Development..... 197

Article 6-5 Grading and Erosion Criteria..... 197

    Part. 6-5(A) Slope Criteria .....197

    Part. 6-5(B) Grading near the Property Line.....197

    Part. 6-5(C) Grading In and Adjacent to Major Facilities.....197

    Part. 6-5(D) Grading In and Adjacent to Major Public Open Space.....198

    Part. 6-5(E) Means of Erosion Control.....198

    Part. 6-5(F) Levees and Berms.....199

        Section. 6-5(F)(1) Definitions .....199

        Section. 6-5(F)(2) Design Criteria.....199

        Section. 6-5(F)(3) Earthwork for Berms.....200

        Section. 6-5(F)(4) Certification .....200

Article 6-6 Valley Drainage Criteria..... 200

    Part. 6-6(A) Single Lot Residential Development and Additions .....200

    Part. 6-6(B) Residential Subdivisions.....200

    Part. 6-6(C) Non-Single Family Residential Development and Commercial Prop-  
erties .....201

    Part. 6-6(D) Flat Grading Scheme for Residential Subdivisions.....201

Article 6-7 Developing in or Adjacent to a Flood Zone..... 202

    Part. 6-7(A) Grading.....202

    Part. 6-7(B) Compensatory Volume.....202

    Part. 6-7(C) AO Zone.....202

        Section. 6-7(C)(1) Determination of Base Flood Elevation (BFE) in an  
AO Zone.....202

    Part. 6-7(D) A Zone.....203

Part. 6-7(E) Floodplain Development Permit .....203  
 Part. 6-7(F) Letters of Map Change (LOMC) .....203  
 Part. 6-7(G) Project Requirements .....203  
 Article 6-8 Downstream Capacity and Offsite Flows..... 204  
     Part. 6-8(A) Downstream Capacity.....204  
     Part. 6-8(B) Offsite Flows.....204  
     Part. 6-8(C) Historic Flow Path through Adjacent Private Property.....204  
 Article 6-9 Engineered Channels and Natural Arroyos..... 205  
     Part. 6-9(A) General Hydraulic Criteria.....205  
     Part. 6-9(B) Sharp Curves .....205  
     Part. 6-9(C) Maximum Froude Number.....205  
     Part. 6-9(D) Water Surface Profile Calculations.....205  
         Section. 6-9(D)(1) Determination of Controlling Water Surface Elevation .....206  
         Section. 6-9(D)(2) Direction of Calculation .....206  
         Section. 6-9(D)(3) Head Losses .....206  
         Section. 6-9(D)(4) Channel Inlets .....207  
         Section. 6-9(D)(5) Bank Protection .....210  
         Section. 6-9(D)(6) Piers .....210  
         Section. 6-9(D)(7) Curving Alignments .....210  
         Section. 6-9(D)(8) Freeboard .....212  
     Part. 6-9(E) Channel Design Criteria .....213  
         Section. 6-9(E)(1) Unlined Channels .....213  
         Section. 6-9(E)(2) Composite Linings .....214  
         Section. 6-9(E)(3) Maximum Sidewall Slopes .....214  
         Section. 6-9(E)(4) Channel Maintenance and Access Road .....214  
         Section. 6-9(E)(5) Channel Access Ramps .....214  
         Section. 6-9(E)(6) Street Crossings .....215  
         Section. 6-9(E)(7) Subdrainage .....215  
         Section. 6-9(E)(8) Channel bed width.....215  
     Part. 6-9(F) Miscellaneous Hydraulic Calculations.....215  
         Section. 6-9(F)(1) Hydraulic Jump.....215  
         Section. 6-9(F)(2) Trash Rack Head Loss.....216  
         Section. 6-9(F)(3) Side Channel Weirs.....217  
     Part. 6-9(G) Channel Treatment Selection Guidelines .....217  
         Section. 6-9(G)(1) General.....217  
         Section. 6-9(G)(2) Flood Control.....218  
         Section. 6-9(G)(3) Drainage.....218  
         Section. 6-9(G)(4) Maintenance.....218  
         Section. 6-9(G)(5) Rights-of-Way and Easements.....218  
         Section. 6-9(G)(6) Safety and Fence Requirements.....218  
         Section. 6-9(G)(7) Upstream and Downstream Channel Treatments  
                 218  
         Section. 6-9(G)(8) Initial Cost and Life Expectancy.....219  
         Section. 6-9(G)(9) Joint Use Possibilities.....219  
         Section. 6-9(G)(10) Sediment Transport and Channel Stability.....219  
         Section. 6-9(G)(11) Channel Stability .....219  
         Section. 6-9(G)(12) Channel Construction Details .....220  
 Article 6-10 Street Hydraulics ..... 222  
     Part. 6-10(A) Street Hydraulic Design Criteria.....222  
     Part. 6-10(B) Option to Drain the Street to the Median.....222  
     Part. 6-10(C) Effects of Hydraulic Jump or Superelevation.....223  
     Part. 6-10(D) Intersection.....223  
     Part. 6-10(E) Drainage Design Criteria in Street Design.....223

Part. 6-10(F) Inlet Placement and Design Criteria .....224  
     Section. 6-10(F)(1) Standard Inlets .....224  
     Section. 6-10(F)(2) Cattle-Guard and Median inlets .....229  
     Section. 6-10(F)(3) Publicly-Maintained Inlets To Be Located Within  
     Street Rights-of-Way.....229  
     Section. 6-10(F)(4) Inlets in a Sump Condition .....230  
 Part. 6-10(G) Inlet Lateral and Connector Pipe Capacity .....230  
     Section. 6-10(G)(1) Connector and Lateral Pipe Criteria .....231  
     Section. 6-10(G)(2) Consideration of Existing Drainage Systems During  
     Construction .....231  
 Article 6-11 Criteria for Hydraulic Design of Closed Conduits ..... 232  
     Part. 6-11(A) General Hydraulic Criteria.....232  
     Part. 6-11(B) Hydraulic Grade Line Calculations .....232  
         Section. 6-11(B)(1) Determination of Control Water Surface Elevation  
         232  
     Part. 6-11(C) Instructions for Hydraulic Calculations .....233  
         Section. 6-11(C)(1) Head Losses .....234  
     Part. 6-11(D) Design Requirements for Maintenance and Access .....236  
         Section. 6-11(D)(1) Manholes .....236  
         Section. 6-11(D)(2) Pressure Manholes .....237  
         Section. 6-11(D)(3) Special Manholes .....237  
         Section. 6-11(D)(4) Deep Manholes .....237  
         Section. 6-11(D)(5) Bends.....237  
         Section. 6-11(D)(6) Curvilinear Storm Drain.....237  
     Part. 6-11(E) Closed Conduit Pipe Size and Slope.....238  
         Section. 6-11(E)(1) Minimum Pipe Size .....238  
         Section. 6-11(E)(2) Minimum Slope .....238  
     Part. 6-11(F) Earthen Channels to Storm Drain Structures .....238  
     Part. 6-11(G) Storm Drain Outlets to Public Earthen Arroyos and Ponds.....238  
         Section. 6-11(G)(1) Incorporation of “Urban Storm Drainage Criteria  
         Manual Volume 2” from the Urban Drainage and Flood Control Dis-  
         trict, Denver, Colorado .....238  
         Section. 6-11(G)(2) Private Storm Drain Outlets to Onsite Basins or  
         Swales.....254  
     Part. 6-11(H) Protection and Debris Barriers.....254  
         Section. 6-11(H)(1) Protection Barriers .....254  
         Section. 6-11(H)(2) Debris Barriers .....255  
         Section. 6-11(H)(3) Debris Basins .....255  
     Part. 6-11(I) Closed Conduit Angle of Confluence .....255  
     Part. 6-11(J) Flapgates .....256  
     Part. 6-11(K) Rubber-Gasketed Pipe .....256  
     Part. 6-11(L) Junctions into Existing Storm Drain Main Lines.....256  
     Part. 6-11(M) Submittal Requirements.....256  
         Section. 6-11(M)(1) Hydraulic Model .....256  
         Section. 6-11(M)(2) Culverts .....257  
 Article 6-12 Pond Requirements..... 257  
     Part. 6-12(A) Design Requirements.....257  
         Section. 6-12(A)(1) Detention Ponds.....257  
         Section. 6-12(A)(2) Retention Ponds.....257  
         Section. 6-12(A)(3) Surge Ponds .....258  
         Section. 6-12(A)(4) Stormwater Quality Ponds .....258  
     Part. 6-12(B) Infiltration Rate .....258  
     Part. 6-12(C) Ponds in Parking Areas .....259  
     Part. 6-12(D) Fencing Around Ponds .....259

Part. 6-12(E) Private Ponds to be Built to Public Pond Specifications.....259

Part. 6-12(F) Rock Void Space for Pond Volume.....259

Part. 6-12(G) Privately Maintained Ponds with a Public Drainage Easement ...259

Part. 6-12(H) City Maintained Ponds .....260

    Section. 6-12(H)(1) Access .....260

    Section. 6-12(H)(2) Spillways.....260

    Section. 6-12(H)(3) Outlets.....260

    Section. 6-12(H)(4) Pond Bottoms.....260

    Section. 6-12(H)(5) Side Slope and Bottom Treatments .....260

    Section. 6-12(H)(6) Minimum Pond Size.....260

    Section. 6-12(H)(7) Fencing .....261

Part. 6-12(I) Temporary Public Ponds .....261

Part. 6-12(J) Pond Evacuation Time.....261

Part. 6-12(K) Infiltration System Design .....261

Article 6-13 Stormwater Quality and Low Impact Development ..... 262

    Part. 6-13(A) Low Impact Development Strategies.....263

    Part. 6-13(B) Effective Strategies for Stormwater Treatment.....263

        Section. 6-13(B)(1) Landscape Category.....264

        Section. 6-13(B)(2) Paving Category.....266

        Section. 6-13(B)(3) Elevated Category .....266

        Section. 6-13(B)(4) Streetscape Category.....267

        Section. 6-13(B)(5) Flood Control Category.....267

        Section. 6-13(B)(6) Offsite Mitigation Category.....267

        Section. 6-13(B)(7) Payment-in-Lieu .....267

    Part. 6-13(C) Variance from On-site Stormwater Quality Volume Requirements  
268

        Section. 6-13(C)(1) Payment-in-Lieu.....269

        Section. 6-13(C)(2) Annual Adjustment of Fee.....269

        Section. 6-13(C)(3) Payment of Fee.....269

    Part. 6-13(D) Land Uses that Require Additional Stormwater Controls.....272

        Section. 6-13(D)(1) Automotive Repair and Parts Shops .....272

        Section. 6-13(D)(2) Restaurants and Commercial Food Processing 272

        Section. 6-13(D)(3) Gas Stations/Fueling Facilities.....272

    Part. 6-13(E) Post-Construction Maintenance and Responsibilities .....272

        Section. 6-13(E)(1) City Post-Construction Inspections .....273

    Part. 6-13(F) Construction Site Responsibility By Property Owner .....273

    Part. 6-13(G) Construction Site Maintenance and Inspections.....274

Article 6-14 Drainage Right-of-Way and Easements..... 285

    Part. 6-14(A) Rights-of-Way .....285

    Part. 6-14(B) Easements.....285

    Part. 6-14(C) Configuration .....285

        Section. 6-14(C)(1) Surface Facilities .....285

        Section. 6-14(C)(2) Public Underground Facilities .....285

    Part. 6-14(D) Drainage Right-of-Way and Public Drainage Easement Access ..286

    Part. 6-14(E) Private Storm Drain Improvements Within City Right-of-Way and/or  
Easements.....286

Article 6-15 Drainage and Stormwater Quality Submittals ..... 287

    Part. 6-15(A) Introduction .....287

        Section. 6-15(A)(1) Drainage Report .....287

        Section. 6-15(A)(2) Conceptual Grading and Drainage Plan .....287

        Section. 6-15(A)(3) Grading and Drainage Plan.....287

        Section. 6-15(A)(4) Erosion and Sediment Control Plan.....287

        Section. 6-15(A)(5) LOMR, CLOMR and LOMR-F (LOMC) submittals  
287

Section. 6-15(A)(6) Engineer's Certifications.....288  
 Section. 6-15(A)(7) Pad Certification.....288  
 Section. 6-15(A)(8) Drainage and Erosion and Sediment Control Submittals for Approval Sought.....288  
 Part. 6-15(B) Drainage Submittal Criteria.....289  
     Section. 6-15(B)(1) Executive Summary.....290  
     Section. 6-15(B)(2) Introduction.....290  
     Section. 6-15(B)(3) Project Description.....291  
     Section. 6-15(B)(4) Background Documents.....291  
     Section. 6-15(B)(5) Existing Conditions.....291  
     Section. 6-15(B)(6) Developed Conditions.....293  
     Section. 6-15(B)(7) Grading Plan.....294  
     Section. 6-15(B)(8) Calculations.....294  
     Section. 6-15(B)(9) Conclusion.....294  
 Part. 6-15(C) Grading Plan Checklist.....294  
     Section. 6-15(C)(1) General Information.....294  
     Section. 6-15(C)(2) Existing Conditions.....295  
     Section. 6-15(C)(3) Proposed Conditions.....296  
 Part. 6-15(D) Erosion and Sediment Control Plan Checklist.....297  
 Part. 6-15(E) Conceptual Grading and Drainage Plan Submittal Criteria.....298  
 Part. 6-15(F) Engineer's Certification for Non-Subdivisions.....298  
 Part. 6-15(G) Engineer's Certification for Subdivisions.....299  
 Part. 6-15(H) Required Certification Language.....300  
 Article 6-16 Maintenance and Post-Construction Responsibility.....301  
     Part. 6-16(A) Fenced & Gated Public Facilities.....301  
     Part. 6-16(B) Drainage Maintenance Plan.....301  
         Section. 6-16(B)(1) Purpose.....301  
         Section. 6-16(B)(2) Plan Outline.....302  
     Part. 6-16(C) Drainage Maintenance Covenants.....302  
         Section. 6-16(C)(1) Applicability.....302  
         Section. 6-16(C)(2) Procedures for Covenants.....302  
         Section. 6-16(C)(3) Procedures for Plats.....303  
 Article 6-17 Common Equations.....304  
     Part. 6-17(A) Weirs.....304  
     Part. 6-17(B) Orifices.....304  
     Part. 6-17(C) Manning's Equation and Coefficient.....305  
 Article 6-18 History.....306  
 Article 6-19 Reference.....310  
     Part. 6-19(A) Hydraulics.....310  
         Section. 6-19(A)(1) Weirs and Orifices.....310  
         Section. 6-19(A)(2) Closed Conduits.....310  
         Section. 6-19(A)(3) Channels.....310  
         Section. 6-19(A)(4) Catch Basins.....310  
         Section. 6-19(A)(5) Street Hydraulics.....311  
         Section. 6-19(A)(6) Berms and Levees.....311

**CHAPTER 7 TRANSPORTATION DESIGN.....312**

Article 7-2 Introduction.....316  
 Article 7-3 Purpose and Scope.....316  
     Part. 7-3(A) Governing Regulations.....317  
         Section. 7-3(A)(1) Albuquerque/Bernalillo County Comprehensive Plan 317  
         Section. 7-3(A)(2) Integrated Development Ordinance (Article 14-16 ROA 1994).....317



Section. 7-3(A)(3) Drainage Ordinance (Part 14-5-2 ROA 1994)...317  
 Section. 7-3(A)(4) Street Tree Ordinance (Article 6-6 ROA 1994)...317  
 Section. 7-3(A)(5) Traffic Code (Chapter 8 ROA 1994) .....318  
 Section. 7-3(A)(6) Streets and Sidewalk Ordinance (Chapter 6-5 ROA 1994).....318  
 Section. 7-3(A)(7) Long Range Transportation System Guide (LRTS) 318  
 Section. 7-3(A)(8) Bikeway & Trails Facility Plan .....318  
 Section. 7-3(A)(9) Corridor Studies.....318  
 Section. 7-3(A)(10) Reference List and Other Applicable Design Manuals and Resources.....319  
 Part. 7-3(B) Using the DPM to Determine Roadway Specifications .....320  
 Section. 7-3(B)(1) Roadway Evaluation Process.....320  
 Section. 7-3(B)(2) Standards versus Guidelines .....321  
 Section. 7-3(B)(3) Design Variance.....321  
 Section. 7-3(B)(4) Roadway Evaluation.....321  
 Section. 7-3(B)(5) Other Design Considerations .....322  
 Part. 7-3(C) Street Elements.....323  
 Section. 7-3(C)(1) Pedestrian Realm .....323  
 Section. 7-3(C)(2) Travel Way.....324  
 Section. 7-3(C)(3) Design Speed .....326  
 Section. 7-3(C)(4) Street Element Table.....327  
 Article 7-4 Roadway Design Context ..... 329  
 Part. 7-4(A) Transportation Planning and Policy .....329  
 Part. 7-4(B) Regional Transportation Planning .....330  
 Section. 7-4(B)(1) Metropolitan Transportation Plan.....330  
 Section. 7-4(B)(2) Long Range Transportation Systems Guide .....332  
 Section. 7-4(B)(3) Functional Classification .....334  
 Section. 7-4(B)(4) Right of Way Ranges .....337  
 Part. 7-4(C) City of Albuquerque-Bernalillo County Comprehensive Plan.....338  
 Section. 7-4(C)(1) General Purpose.....338  
 Section. 7-4(C)(2) Implications for the DPM.....339  
 Section. 7-4(C)(3) Comp Plan Corridors.....339  
 Section. 7-4(C)(4) Comp Plan Centers .....341  
 Section. 7-4(C)(5) Policy Matrices.....343  
 Section. 7-4(C)(6) Other Considerations.....344  
 Part. 7-4(D) City of Albuquerque Complete Streets Ordinance .....345  
 Section. 7-4(D)(1) Definition of Complete Streets.....345  
 Section. 7-4(D)(2) Purpose of Ordinance.....345  
 Section. 7-4(D)(3) Street Design and Implementation .....345  
 Section. 7-4(D)(4) Connection between the Complete Streets Ordinance and the DPM.....346  
 Part. 7-4(E) Principles of Network Design and Roadway Connectivity.....346  
 Section. 7-4(E)(1) Connectivity.....346  
 Section. 7-4(E)(2) Regional Connectivity and Spacing of Major Roads 347  
 Section. 7-4(E)(3) Neighborhood Connectivity .....348  
 Section. 7-4(E)(4) Intersection Density.....348  
 Section. 7-4(E)(5) Regional Network Considerations.....349  
 Article 7-5 Design Standards..... 350  
 Part. 7-5(A) Network Connectivity.....350  
 Section. 7-5(A)(1) Purpose of Section.....350  
 Section. 7-5(A)(2) Definition of terms .....350  
 Section. 7-5(A)(3) Connectivity .....352

Section. 7-5(A)(4) General Network Considerations.....	354
Section. 7-5(A)(5) Block Lengths.....	355
Section. 7-5(A)(6) Traffic Signal Spacing.....	355
Section. 7-5(A)(7) Designated Pedestrian Crossings.....	357
Part. 7-5(B) Site Access Points.....	361
Section. 7-5(B)(1) Definitions.....	361
Section. 7-5(B)(2) General Guidance and Curb Cut Ordinance.....	361
Section. 7-5(B)(3) Pedestrian Access.....	362
Section. 7-5(B)(4) Vehicular Access.....	362
Section. 7-5(B)(5) Curb Return Design.....	365
Section. 7-5(B)(6) Access Control.....	367
Section. 7-5(B)(7) Striping and Signage.....	368
Section. 7-5(B)(8) Roadways in NMDOT Jurisdiction.....	368
Part. 7-5(C) Pavement Design.....	368
Section. 7-5(C)(1) General Provisions.....	368
Section. 7-5(C)(2) Subgrade Materials Evaluation.....	368
Section. 7-5(C)(3) Traffic Factors in Pavement Design.....	371
Section. 7-5(C)(4) Structural Design of Pavement.....	373
Section. 7-5(C)(5) Flexible Pavements Design.....	375
Section. 7-5(C)(6) Portland Cement Concrete Design.....	377
Section. 7-5(C)(7) Alternative Pavement.....	377
Part. 7-5(D) Curb and Gutter.....	378
Section. 7-5(D)(1) Public Right of Way Requirements.....	378
Section. 7-5(D)(2) Private Property Requirements.....	378
Part. 7-5(E) Pedestrian Facilities.....	378
Section. 7-5(E)(1) Public Sidewalks.....	379
Section. 7-5(E)(2) Pedestrian Walkways.....	389
Part. 7-5(F) Bikeways and Trails.....	390
Section. 7-5(F)(1) General Provisions.....	390
Section. 7-5(F)(2) Locations of Future Facilities.....	391
Section. 7-5(F)(3) Bicycle Lanes.....	391
Section. 7-5(F)(4) Bicycle Routes.....	393
Section. 7-5(F)(5) Bicycle Boulevards.....	393
Section. 7-5(F)(6) Paved Trails.....	394
Section. 7-5(F)(7) Trail Alternatives.....	396
Part. 7-5(G) Public Transit.....	396
Section. 7-5(G)(1) General Provisions.....	396
Section. 7-5(G)(2) Pedestrian Connections to Transit Stops.....	397
Section. 7-5(G)(3) Boarding and Alighting Areas.....	397
Section. 7-5(G)(4) Transit Stop Types.....	399
Section. 7-5(G)(5) Roadway Design Considerations for Transit in Mixed Flow Traffic.....	401
Section. 7-5(G)(6) Dedicated Transit Infrastructure.....	404
Part. 7-5(H) On-Street Parking.....	405
Section. 7-5(H)(1) General Provisions.....	405
Section. 7-5(H)(2) Design Guidance.....	406
Section. 7-5(H)(3) Maintenance and Parking Agreements.....	409
Section. 7-5(H)(4) Creation of New On-Street Parking During Site Development.....	410
Section. 7-5(H)(5) Parklets.....	410
Part. 7-5(I) Geometric Design Criteria.....	412
Section. 7-5(I)(1) General Design Criteria.....	413
Section. 7-5(I)(2) Horizontal Alignment.....	413
Section. 7-5(I)(3) Superelevation.....	413

Section. 7-5(I)(4) Vertical Alignment.....	414
Section. 7-5(I)(5) Sight Distance .....	415
Section. 7-5(I)(6) Intersection Design.....	419
Section. 7-5(I)(7) Median and Turn Lane Design.....	424
Part. 7-5(J) Local Streets.....	432
Section. 7-5(J)(1) Local Street Classifications.....	432
Section. 7-5(J)(2) Local Street Design.....	434
Section. 7-5(J)(3) Stub, Cul-de-Sac, and Loop Street Criteria.....	436
Section. 7-5(J)(4) Emergency Service Access to Local Streets.....	437
Section. 7-5(J)(5) Private Streets.....	438
Section. 7-5(J)(6) Private Ways.....	438
Section. 7-5(J)(7) Entrance and Gate Requirements for Private Ways and Streets.....	439
Part. 7-5(K) Off-Street Parking and Site Design .....	439
Section. 7-5(K)(1) General Provisions.....	439
Section. 7-5(K)(2) Bicycle Parking.....	440
Section. 7-5(K)(3) Motorcycle Parking.....	441
Section. 7-5(K)(4) Standard and Small Car Parking.....	441
Section. 7-5(K)(5) ADA Accessible Parking.....	442
Section. 7-5(K)(6) Angled Parking .....	443
Section. 7-5(K)(7) Pavement of Parking Areas .....	444
Section. 7-5(K)(8) Curbing in Parking Areas.....	445
Section. 7-5(K)(9) Grading in Parking Areas.....	445
Section. 7-5(K)(10) Sidewalk Connections.....	445
Section. 7-5(K)(11) Site Access.....	445
Section. 7-5(K)(12) Fire and Emergency Access.....	446
Section. 7-5(K)(13) Solid Waste Access.....	446
Section. 7-5(K)(14) Access Throat Length and Queuing .....	446
Section. 7-5(K)(15) Site Layout and Circulation .....	447
Section. 7-5(K)(16) Parking Islands.....	447
Section. 7-5(K)(17) Service Areas.....	448
Section. 7-5(K)(18) Signage & Striping .....	448
Section. 7-5(K)(19) Drive-Through Facilities.....	448
Section. 7-5(K)(20) Layout of Large Parking Areas.....	449
Section. 7-5(K)(21) Traffic Circulation Layout Requirements.....	449
Part. 7-5(L) Traffic Calming.....	449
Section. 7-5(L)(1) Neighborhood Traffic Calming .....	449
Section. 7-5(L)(2) Speed Management on Major Roads.....	449
Part. 7-5(M) Street Lighting.....	451
Section. 7-5(M)(1) Roadway Lighting Criteria .....	451
Section. 7-5(M)(2) New Lighting System Considerations.....	453
Section. 7-5(M)(3) Distribution Criteria .....	453
Section. 7-5(M)(4) Correlated Color Temperature (CCT).....	453
Section. 7-5(M)(5) Luminaire Criteria .....	454
Section. 7-5(M)(6) Street Lighting Development Build out Require- ments.....	455
Part. 7-5(N) Traffic Control and Development Requirements.....	456
Section. 7-5(N)(1) Traffic Control & Phasing Plan.....	456
Section. 7-5(N)(2) Traffic Construction and Fees.....	456
Part. 7-5(O) Naming of Streets.....	457
Section. 7-5(O)(1) Markings.....	458
Section. 7-5(O)(2) Signage .....	458
Section. 7-5(O)(3) Traffic Signals.....	459

Section. 7-5(O)(4) Barricades at Ends of Pavements Signage .....459

Article 7-6 Traffic Studies ..... 460

Part. 7-6(A) Background and Purpose .....460

Part. 7-6(B) Traffic Scoping Form and Traffic Impact Study .....461

Section. 7-6(B)(1) Traffic Scoping Form .....461

Section. 7-6(B)(2) Traffic Impact Study.....461

Part. 7-6(C) Traffic Study Warranting Criteria .....462

Section. 7-6(C)(1) Traffic Scoping Form Warranting Criteria.....463

Section. 7-6(C)(2) Traffic Impact Study Warranting Criteria .....464

Part. 7-6(D) Traffic Analysis Procedures.....464

Section. 7-6(D)(1) Traffic Scoping Forms.....464

Section. 7-6(D)(2) Traffic Impact Studies .....465

Part. 7-6(E) TIS Report Elements.....466

Section. 7-6(E)(1) Executive Summary .....466

Section. 7-6(E)(2) Introduction .....466

Section. 7-6(E)(3) 4.5.3 Existing Conditions.....467

Section. 7-6(E)(4) Future Traffic Conditions and Analysis Years.....469

Section. 7-6(E)(5) Proposed Site Traffic Characteristics.....470

Section. 7-6(E)(6) Traffic Analysis.....471

Section. 7-6(E)(7) Site Access Requirements.....473

Section. 7-6(E)(8) Summary of Findings .....473

Section. 7-6(E)(9) Recommendations and Mitigation Measures .....473

Section. 7-6(E)(10) Appendix .....475

Part. 7-6(F) NIA- Neighborhood Impact Assessment .....475

Section. 7-6(F)(1) NIA Purpose/Scope.....475

Section. 7-6(F)(2) NIA Minimum Requirements.....475

Article 7-7 Definitions..... 476

**CHAPTER 8 SANITARY SEWER DESIGN CRITERIA ..... 487**

Article 8-2 GOVERNING REGULATIONS..... 488

Article 8-3 AVAILABILITY STATEMENTS ..... 488

Article 8-4 Design Capacity Criteria Section, Development and Development Service..... 489

Article 8-5 Manhole Criteria ..... 490

Article 8-6 Line Criteria ..... 492

Article 8-7 Curvilinear Sewers..... 494

Article 8-8 Service Connections Criteria ..... 495

Part. 8-8(A) Private collection systems and individual service connections .....495

**CHAPTER 9 WATER SYSTEM DESIGN CRITERIA..... 496**

Article 9-2 GOVERNING REGULATIONS..... 497

Article 9-3 AVAILABILITY STATEMENTS ..... 497

Article 9-4 WATER LINE DESIGN CRITERIA..... 497

Part. 9-4(A) General Requirements .....497

Part. 9-4(B) Single-Family and Duplex ..... Developments .....498

Part. 9-4(C) Industrial/Commercial and Multi-Family Developments .....498

Part. 9-4(D) Material Requirements .....498

Part. 9-4(E) Waterline Designations .....498

Part. 9-4(F) Minimum Waterline Depths.....499

Part. 9-4(G) Thrust Restraints.....499

Part. 9-4(H) Water Valve Shut Off Plans.....499

Article 9-5 ALIGNMENT AND EASEMENTS ..... 500

Article 9-6 VALVING..... 502  
Article 9-7 SERVICE LINES AND METERS..... 503  
Article 9-8 PRIVATE DISTRIBUTION SYSTEMS ..... 504  
Article 9-9 FIRE HYDRANT CRITERIA ..... 504  
    Part. 9-9(A) General Information ..... 504  
    Part. 9-9(B) General Fire Hydrant Requirements for Fire Protection..... 505  
    Part. 9-9(C) New Buildings, Building Additions or Building Reconstruction..... 506  
    Part. 9-9(D) Existing Development and building Fire Hydrant Deficiencies ..... 507  
    Part. 9-9(E) Public Fire Hydrant Installation Procedure ..... 507  
Article 9-10 FIRE FLOW REQUIREMENTS..... 508

**CHAPTER 10 SURVEYS AND MONUMENTATION..... 509**

Article 10-1 GOVERNING REGULATIONS ..... 510  
Article 10-2 REGULATED CRITERIA AND APPLICATION..... 510  
    Part. 10-2(A) Monumentation ..... 511  
        Section. 10-2(A)(1) Subdivision Control Monuments ..... 511  
        Section. 10-2(A)(2) Permanent Survey Monuments ..... 511  
        Section. 10-2(A)(3) Bench Marks..... 512  
    Part. 10-2(B) Albuquerque Geodetic Reference ..... 513  
    Part. 10-2(C) Records Requirements..... 513  
Article 10-3 CONSTRUCTION SURVEYS ..... 514

**CHAPTER 11 LANDSCAPE AND IRRIGATION ..... 515**

Article 11-1 Governing Regulations ..... 516  
Article 11-2 GENERAL DESIGN CRITERIA..... 517  
    Part. 11-2(A) General Design Criteria: Medians ..... 517  
    Part. 11-2(B) General Design Criteria: Medians..... 518  
Article 11-3 IRRIGATION DESIGN CRITERIA..... 518  
    Part. 11-3(A) Irrigation Design Criteria: Medians ..... 518  
    Part. 11-3(B) Irrigation Design Criteria: Medians ..... 519  
Article 11-4 PLANTING DESIGN CRITERIA..... 520  
    Part. 11-4(A) Planting Design Criteria: Medians ..... 520  
    Part. 11-4(B) Planting Design Criteria: Medians..... 520  
Article 11-5 REFERENCE ..... 520  
Article 11-6 GREENSPACE INITIATIVE ..... 521  
    Part. 11-6(A) Greenspace Initiative Intent ..... 521  
    Part. 11-6(B) Greenspace Initiative ..... 521

# CHAPTER 1

## OVERVIEW

### CONTENTS

<b>ARTICLE 1-1 THE DEVELOPMENT PROCESS MANUAL (DPM)</b>	
<b>INTRODUCTION .....</b>	<b>2</b>
<b>ARTICLE 1-2 PURPOSE OF THE DPM .....</b>	<b>3</b>
<b>ARTICLE 1-3 RELATIONSHIP TO OTHER REGULATORY DOCUMENTS .....</b>	<b>4</b>
Part. 1-3(A) Integrated development ordinance (IDO) .....	4
Part. 1-3(B) Standard Specifications .....	4
Section. 1-3(B)(1) NEW MEXICO STANDARD SPECIFICATIONS FOR PUBLIC WORKS CONSTRUCTION, CURRENT EDITION .....	4
Part. 1-3(C) Contract Documents for City -Wide Utilities and Cash Paving, current edition.....	4
Part. 1-3(D) Standard Details .....	5
Part. 1-3(E) Reference Lists and Other Applicable Design Manuals and Resources.....	5
Part. 1-3(F) Abbreviations.....	5
<b>ARTICLE 1-4 DPM UPDATE PROCEDURE .....</b>	<b>7</b>
Part. 1-4(A) User Comments.....	7
Part. 1-4(B) Committees Responsible for Review of Administrative Changes .....	7
Section. 1-4(B)(1) DPM Executive Committee.....	7
Section. 1-4(B)(2) DPM Subcommittees .....	8
Part. 1-4(C) Procedure for Changing the Administrative Rules.....	8
Part. 1-4(D) NOTIFICATION OF PROPOSED RULE CHANGES .....	9
Part. 1-4(E) EMERGENCY EFFECTIVE DATE.....	9
Part. 1-4(F) APPEALS .....	10

## **ARTICLE 1-1 THE DEVELOPMENT PROCESS MANUAL (DPM) INTRODUCTION**

The publication of the Development Process Manual (DPM) is in response to a mutual need by both the private and public sectors to coordinate and clarify the complexities of the development process of the City of Albuquerque. The Albuquerque/Bernalillo County Comprehensive Plan and other adopted plans are the foundation of the development process guiding the procedures, design criteria, and standards presented in this document. More detailed regulations are contained in the Integrated Development Ordinance (IDO), other ordinances related to specific issues of development, and City-adopted uniform



building and technical codes. DPM content is informed by the following regulatory documents:

- Adopted City plans, particularly the [\*Albuquerque/Bernalillo County Comprehensive Plan and the Integrated Development Ordinance \(IDO\)\*](#), provide direction for City-initiated development and private development. Plans are available from the Planning Department. They are not part of the DPM.
- Legislation regulating development is published in the compilation of City ordinances, [\*Revised Ordinances of Albuquerque, 1994\*](#) (abbreviated as “R.O.A. 1994”). It is also available online at [\*American Legal Publishing Corporation\*](#), for sale, copying of pages, or reading at the office of the City Clerk. A few Key ordinances are published separately and sold at the City Treasurer’s office. The most important relevant legislative provisions are reflected in the DPM.
- When legislative policies are adopted, the legislative body may mandate or allow administrative staff involved in carrying out its policies to develop more detailed rules and guidelines for policy implementation. The development of detailed rules and guidelines by administrative staff is referred to as Administrative Rule making. These rules are the heart of the DPM. They are not always available elsewhere.

The DPM effort began in February, 1981, with the establishment of a special team of City staff and Albuquerque Urban Advisory Council members. The document has undergone several revisions as the document isn’t intended to remain stagnant, but to evolve as the need for new or updated standards are identified. DPM users – City staff, property owners, developers and their agents, especially planners, architects and engineers – are encouraged to submit suggestions, corrections and proposed modifications in writing, at any time per the procedures outlined in [\*Section Article 1-4 DPM Update Procedure\*](#).

## ARTICLE 1-2 PURPOSE OF THE DPM

The general purpose of the DPM is to carry out the goals and policies of the Albuquerque/Bernalillo County Comprehensive Plan by encouraging high-quality, innovative design; variety in choice of neighborhoods and lifestyles; preservation of natural features and resources; and ensuring the health, safety and welfare of the community.

The DPM delineates the development process from initial land use proposals, through infrastructure construction, to completion of a proposed development. It is intended for use of City staff, property owners, developers and their agents, especially planners, architects and engineers to:

- Coordinate and clarify the development process of the City of Albuquerque.
- Provide the basic criteria necessary to assure acceptable levels of performance and safety for public facilities related to development and to assure adequate monumentation and documentation of land division.
- Give City staff a readily-accessible reference to uniform standards by which to evaluate development submittals, in a consistent and expeditious manner.

*Chapter 2 Development Procedures* of the DPM describes the basic procedures of the development process with an attempt to integrate specific procedures with other related requirements (e.g., infrastructure design procedures with recordable documents criteria) while Chapters 4-12 outline minimum design standards and criteria and presents examples of acceptable methodology for the design of infrastructure improvements required in developments.

Use of the DPM assumes compliance with all legal requirements and the exercise of sound professional judgment by design professionals familiar with development in all its aspects from land division through design and construction of infrastructure to completion. It also emphasizes the professional obligations and responsibilities of City staff and the development community. While the DPM highlights those development activities which occur most frequently, there is no way to adequately address all development proposals or all aspects within all proposals. Unique situations will continue to be handled on a case-by-case basis.

## **ARTICLE 1-3 RELATIONSHIP TO OTHER REGULATORY DOCUMENTS**

The Development Process Manual contains engineering design criteria and standards for the infrastructure system necessary to development. Generally, an abbreviated style of presenting material has been used as this document is not intended to be a text or primer. Users are expected to have knowledge of or access to the fundamental concepts of the respective discipline by which the criteria are to be applied. The criteria presented in this document are to be utilized and applied in conjunction with the following additional documents to accomplish the completed design of facilities:

### **Part. 1-3(A) Integrated development ordinance (IDO)**

This document includes the zoning and subdivision regulations to govern land use and development within the City of Albuquerque and establishes the City's system of planning.

### **Part. 1-3(B) Standard Specifications**

The term "Standard Specifications" refers to both the NM Standard Specifications for Public Works Construction along with the Contract Documents for City-wide Utilities and Cash Paving (see Appendix B)

#### **Section. 1-3(B)(1) NEW MEXICO STANDARD SPECIFICATIONS FOR PUBLIC WORKS CONSTRUCTION, CURRENT EDITION**

This document is the basic construction specification document adopted for use by the City of Albuquerque. It provides both general conditions for construction contracts and technical specifications for materials and installation of infrastructure. It, together with the modifications and supplements thereto published periodically within the Contract Documents for City-Wide Utilities and Cash Paving (see B., following , is referred to as the "Standard Specifications" in the text of this Design Criteria volume. It is available from the American Public Works Association, Specifications Committee, c/o Wilson and Co., Engineers and Architects, P. O. Box 3305, Albuquerque, New Mexico, 87110.

### **Part. 1-3(C) Contract Documents for City-Wide Utilities and Cash Paving, current edition**

This document is a contract document for certain types of infrastructure construction performed within the City and under City auspices. It is important

because it incorporates modifications and supplements to the New Mexico Standard Specifications for Public Works Construction. It is commonly referred to as the “Block-to-Block” Contract. The document is revised and reissued approximately annually. The specification modifications and supplements therein govern development infrastructure as well as City constructed facilities. This document is available from the City Engineer at 600 Second NW, Albuquerque, New Mexico, 87102.

### **Part. 1-3(D) Standard Details**

This document is a compilation of standard designs and details of infrastructure elements prepared by the City Engineer. The Standard Details are to be used normally in the design infrastructure systems.

Standard Details are available as a separate document from the City Engineer or may also be obtained in reduced format bound within the Contract Documents for City Wide Utilities and Cash Paving. Standard Details are normally revised and reissued approximately annually.

### **Part. 1-3(E) Reference Lists and Other Applicable Design Manuals and Resources**

The Standards and guidelines established by this document were drafted based on best practices from national design manuals and standards utilized by similar sized municipalities, many of which are referenced in subsequent chapters on this document. Where external reference documents are in conflict with this DPM, the standards of this DPM shall govern.

### **Part. 1-3(F) Abbreviations**

The following abbreviations or symbols are used in this document:

Reference	Abbreviations
Albuquerque Control Survey	ACS
American Association of State Highway and Transportation Officials	AASHTO
American Institute of Architects	AIA
American National Standards Institute	ANSI
American Society of Landscape Architects	ASLA
American Public Works Association	APWA
American Society of Civil Engineers	ASCE
American Society for Testing and Materials	ASTM
American Water Works Association	AWWA
Average Week Day Traffic	AWDT

Bench Mark	<i>BM</i>
Center to Center	<i>C.C. or C/C</i>
Cast-iron Pipe	<i>Cip</i>
Centerline	<i>C.L. or CL</i>
Concrete	<i>Conc</i>
Department of Municipal Development	<i>City of Albuquerque</i>
Design Review Committee	<i>DRC</i>
Development Review Board	<i>DRB</i>
Elevation	<i>El. or Elev.</i>
Fire Hydrant	<i>FH</i>
Flowline	<i>FL</i>
Federal Highway Administration Department of Transportation	<i>FHWA</i>
Highway Capacity Manual	<i>HCM</i>
Inside Diameter	<i>id</i>
Invert	<i>Inv.</i>
Institute of Traffic Engineers	<i>ITE</i>
Level of Service	<i>LOS</i>
Long Range Major Street Plan	<i>LRMSP</i>
Manual on Uniform Traffic Control Devices	<i>MUTCD</i>
National Geodetic Survey	<i>NGS</i>
New Mexico Statutes Annotated - 1953 Compilation as Amended	<i>NMSA</i>
New Mexico Department of Transportation	<i>NMDOT</i>
Point of Curvature	<i>PC</i>
Property Line	<i>PL</i>
Pounds per Square Inch	<i>psi</i>
Point of Tangency	<i>PT</i>
Public Services Company of New Mexico	<i>PNM</i>
Rate of Flow	<i>Q</i>
Radius	<i>R</i>
Reinforced Concrete Pipe	<i>RCP</i>
Right-of-Way	<i>R/W or R.O.W.</i>
Sanitary	<i>San. or SAS</i>
Storm Drain	<i>SD</i>
Section	<i>Sect.</i>
Specifications	<i>Spec.</i>
Station	<i>Sta.</i>
Traffic Impact Study	<i>TIS</i>
Urban Transportation Planning Policy Board	<i>UTPPB</i>

## **ARTICLE 1-4 DPM UPDATE PROCEDURE**

Establishing and monitoring legislative policy and administrative rules development controls may result from two distinctly different enactment processes. These enactment processes are called Legislative Policy and Administrative Rule-making. The State Legislature enacts statutes. The City Council and County Commission adopt ordinances and resolutions. These are legislative policies which cannot be legally changed by administrative action alone. Only the legislative body adopting the policy may subsequently amend it. However, often when legislative policies are adopted, the legislative body will mandate or allow the public staff involved in carrying out its policies to develop more detailed rules and guidelines for policy implementation. The development of detailed rules and guidelines by public staff is referred to as Administrative Rule-making.

This Development Process Manual (DPM) contains both legislative requirements and administrative rules and procedures affecting development activities in the Albuquerque area. The purpose of this section is to set forth the general procedures by which administrative rules and procedures within the DPM can be changed. Any administrative change that will require a legislative amendment must also follow the amendment procedures set forth in the respective legislation.

### **Part. 1-4(A) User Comments**

The content of the DPM material was prepared jointly by both the private sector and City staff members. The content of the DPM is not intended to remain static; it is expected the cooperative efforts will continue to update content through future revisions.

Users of the DPM are encouraged to note errors, omissions, and conflicts in the content and suggest modifications or topics to be included in future revisions. Any additions, corrections, or clarifications which require immediate action will be issued as addendum or errata sheets to purchasers of the DPM who automatically will be added to the publication list.

The user is encouraged to submit suggestions, corrections, or modifications, in writing, at any time. The procedure for DPM update is outlined in [\*Section Part. 1-4\(C\) Procedure for Changing the Administrative Rules.\*](#)

### **Part. 1-4(B) Committees Responsible for Review of Administrative Changes**

#### **Section. 1-4(B)(1) DPM Executive Committee**

The DPM Executive Committee was established to review and direct changes in the DPM. The DPM Executive Committee consists of 11 individuals from the public and private sectors. Composition of the Executive Committee is as follows:



1. Co-Chairs, Planning Department Director; Municipal Development Department Director
2. Manager or designated representative of the Urban Design and Development Division of the City Planning Department
3. City Engineer, Planning Department
4. City Attorney or designated representative
5. Albuquerque/Bernalillo County Water Utility Authority representative
6. Five members from the private sector who are actively involved in land development either as developers, consultants or planners or represent organizations that are actively involved in land development activities.

### **Section. 1-4(B)(2) DPM Subcommittees**

Proposals to change the DPM may be reviewed by a Subcommittee of the DPM Executive Committee composed of various public and private sector members from professions or companies closely related to various aspects of land development. The Subcommittee is responsible for reviewing and advising the DP Executive Committee on all significant changes to the DPM. The Subcommittee is advisory only and has no authority to override any public agency which is responsible for the enforcement of public policy or is charged with the responsibility of promulgation of new rules, policies, ordinances or procedures.

## **Part. 1-4(C) Procedure for Changing the Administrative Rules**

The proposed change is submitted in letter or memo form to the Administration Office of the Planning Director, 3rd Floor, Plaza Del Sol Building, Albuquerque, New Mexico 87102. The letter is to be accompanied by a brief statement outlining the reason for the proposed change and is to reference the name and address of the firm, organization, agency, or individual proposing the change. In addition, requests should include the DPM text pertaining to the change with single-line strike-through of all material proposed to be deleted, and legible writing, underlined for all new text proposed. Should the proposed change be related to provisions of a City ordinance or resolution, the pertinent section(s) of that ordinance or resolution as enacted shall be referenced in the proposed change.

The request then is reviewed by the DPM Executive Committee. Decisions are based on consent of all members. The Executive Committee determines the merits or validity of the change, and whether further investigation, information or research is needed. If the proposed change requires further study, the Executive Committee will appoint a subcommittee to undertake the work.

Upon completion of the review period, the subcommittee evaluates any comments received for possible rule modification. If the Subcommittee determines that a modification to the proposed rule is appropriate or necessary as a result of comments received, the proposed rule as modified shall go back to the Executive Committee for consideration. Substantial modifications as a result of public review, shall go back to the Executive Committee for final approval.

If the Executive Committee approves the change, notice of the proposed change shall be advertised with all required information at least thirty (30) days prior to its final acceptance date. The purpose of the 30-day notice is to allow for public input. If the Executive Committee rejects the change, written notification shall be given to the requester of the change. The notice shall include a statement outlining the reasons for the rejection.

Once accepted as originally proposed or modified as a result of comments received, the change is official when promulgated by the Mayor and distributed, posted and filed in the Office of the City Clerk.

The final rule changes shall be filed with the City Clerk on or before the effective date. If related to the City's Drainage Ordinance, proposed rule changes shall not take effect sooner than thirty (30) days after final approval by the City Engineer and posting, of notice, or sooner than ninety (90) days from the original distribution of the proposed rule change for comment.

## **Part. 1-4(D) NOTIFICATION OF PROPOSED RULE CHANGES**

Any proposed rule change to the DPM should be published in a newspaper of daily circulation within the City at least thirty days prior to the change becoming effective, unless an emergency effective date applies. In addition, all subscribers to the DPM shall be notified by mail or other method at the address last given to the City. Each such public notice shall contain information identifying who interested parties may contact regarding the proposed change, how comments can be submitted and the substance of the proposed change. Copies of proposed changes shall be available for review in the Planning Department Office, Plaza Del Sol Building, Third Floor.

Once the rule change has been promulgated and filed in the Office of the City Clerk, DPM Subscribers shall be notified of the official amendment. The amendments may be purchased, at the cost of reproduction, in the Planning Department Office. The Planning Department will mail amendments upon request, but the cost of reproduction and postage must be paid prior to mailing.

## **Part. 1-4(E) EMERGENCY EFFECTIVE DATE**

In the case of emergencies, there are two ways that a rule may be changed: For rules not requiring public notice pursuant to adopted City policy, the DP Executive Committee may require emergency implementation of a rule change. The rule can be placed temporarily into effect prior to general public notice by filing a copy of the change clearly marked "Interim Rule" with the City Clerk. However, the rule shall not be final until public notice is provided and update procedures are followed as set forth herein.

In addition, the Mayor may determine in writing that urgent and compelling reasons require emergency modifications of a rule and may adopt such modification and make it effective immediately upon posting and distribution. If such

rule is to be in effect longer than 60 days, public notice shall be given and the opportunity for public comment provided.

## **Part. 1-4(F) APPEALS**

Anyone may appeal a proposed rule change within 15 days of its posting and filing with the City Clerk, or within 15 days of sending notice of final rejection to the proponent of the change. If the proposed rule change is related to implementation of the City's Drainage Ordinance, appeal is to the Technical Standards Committee provided for in Section 15 of the Drainage Ordinance. Appeals for matters other than those related to the City's Drainage Ordinance are to be to the City Council.

Appeal forms may be obtained from the Albuquerque Development and Building Services Permit Center, Garden Level, Plaza Del Sol Building.

# CHAPTER 2

## DEVELOPMENT PROCEDURES

This chapter outlines the development procedures authorized by the City of Albuquerque, detailed requirements for various procedures are covered as follows:

### ARTICLE 2-1 CONTENTS

#### ARTICLE 2-1 DETERMINING THE APPROPRIATE PROCEDURE ..... 9

#### ARTICLE 2-2 SUBDIVISION OF LAND..... 14

Part. 2-2(A) Governing Regulations .....	14
Part. 2-2(B) Standard Subdivision Procedure .....	14
Section. 2-2(B)(1) Applicability .....	14
Section. 2-2(B)(2) Required Application Materials.....	14
Part. 2-2(C) Non-Compliant Parcel Procedure .....	15
Section. 2-2(C)(1) Applicability.....	15
Section. 2-2(C)(2) Procedures .....	15
Part. 2-2(D) Bulk Land Subdivision Variance Criteria .....	16
Section. 2-2(D)(1) Applicability.....	16
Section. 2-2(D)(2) Bulk Land Subdivision Variance Criteria.....	16
Section. 2-2(D)(3) Bulk Land Subdivision Variance Procedure .....	16

#### ARTICLE 2-3 PUBLIC INFRASTRUCTURE IMPROVEMENT PROCEDURES..... 17

Part. 2-3(A) Governing regulations .....	17
Part. 2-3(B) Infrastructure Design Development Procedure .....	18
Section. 2-3(B)(1) Applicability .....	18
Section. 2-3(B)(2) Procedure.....	18
Part. 2-3(C) Construction Agreements (Infrastructure Improvements Agreement - IIA) .....	23
Section. 2-3(C)(1) "Procedure a" .....	23
Section. 2-3(C)(2) "Procedure B" .....	24
Section. 2-3(C)(3) "Procedure C".....	27
Part. 2-3(D) Work Order(s).....	28
Section. 2-3(D)(1) Applicability.....	28
Section. 2-3(D)(2) PROCEDURES .....	28

#### ARTICLE 2-4 PRIVATE INFRASTRUCTURE IMPROVEMENTS..... 39

Part. 2-4(A) Applicability .....	39
Part. 2-4(B) PRIVATE FACILITIES IN PUBLIC RIGHT-OF-WAY .....	40
Part. 2-4(C) Procedural differences.....	40
Section. 2-4(C)(1) PRIVATE INFRASTRUCTURE DESIGN DEVELOPMENT.....	40
Section. 2-4(C)(2) CONSTRUCTION OF PRIVATE INFRASTRUCTURE.....	41

**ARTICLE 2-5 COMMERCIAL, PUBLIC, MULTI-FAMILY BUILDING PERMITS.....42**

Part. 2-5(A) Applicability..... 42  
Part. 2-5(B) Governing Regulations ..... 42  
Part. 2-5(C) Procedure ..... 42  
    Section. 2-5(C)(1) Preliminary Plan Check Services ..... 42  
    Section. 2-5(C)(2) Plan Preparation ..... 43  
    Section. 2-5(C)(3) Application for Plan Check ..... 44  
    Section. 2-5(C)(4) Plan Check ..... 44  
    Section. 2-5(C)(5) Building Permit Issuance..... 44  
    Section. 2-5(C)(6) Construction Inspections ..... 45  
    Section. 2-5(C)(7) Certificate of Occupancy ..... 45

**ARTICLE 2-6 RELATED BUILDING PERMITS ..... 47**

Part. 2-6(A) Demolition Permits..... 51  
    Section. 2-6(A)(1) Applicability..... 51  
    Section. 2-6(A)(2) Procedures..... 51  
Part. 2-6(B) Floodplain Development Permit..... 52  
    Section. 2-6(B)(1) Applicability ..... 52  
    Section. 2-6(B)(2) Procedures..... 52  
Part. 2-6(C) Foundation Only Permits..... 53  
    Section. 2-6(C)(1) Applicability..... 53  
    Section. 2-6(C)(2) Procedures ..... 53  
Part. 2-6(D) Grading Permit and Paving Permit..... 54  
    Section. 2-6(D)(1) Applicability..... 54  
    Section. 2-6(D)(2) Procedure ..... 54  
Part. 2-6(E) Plumbing and Electrical Permits ..... 55  
    Section. 2-6(E)(1) Applicability..... 55  
    Section. 2-6(E)(2) Procedures..... 55  
Part. 2-6(F) Relocation of Existing Buildings Permits ..... 55  
    Section. 2-6(F)(1) Applicability..... 55  
    Section. 2-6(F)(2) Procedures..... 56  
Part. 2-6(G) Sign Permits..... 56  
    Section. 2-6(G)(1) Applicability..... 56  
    Section. 2-6(G)(2) Procedures ..... 57  
Part. 2-6(H) Wall, Fence, and Retaining wall Permits..... 57  
    Section. 2-6(H)(1) Applicability..... 57  
    Section. 2-6(H)(2) Procedures..... 58

**ARTICLE 2-7 OTHER CONSTRUCTION PERMITS..... 59**

Part. 2-7(A) Air Contaminant Sources Registration..... 59  
    Section. 2-7(A)(1) Applicability..... 59  
    Section. 2-7(A)(2) Procedure..... 59  
Part. 2-7(B) Authority-To-Construct Permit ..... 59  
    Section. 2-7(B)(1) Applicability ..... 59  
    Section. 2-7(B)(2) Procedure..... 60  
Part. 2-7(C) Barricade Permit..... 60  
    Section. 2-7(C)(1) Applicability..... 60  
    Section. 2-7(C)(2) Procedure..... 60  
Part. 2-7(D) Blasting Permit..... 61  
    Section. 2-7(D)(1) Applicability..... 61  
    Section. 2-7(D)(2) Procedure ..... 61

Part. 2-7(E) Encroachment Agreement (Approval To Place Private Infrastructure In A Public Easement)..... 61  
     Section. 2-7(E)(1) Applicability.....61  
     Section. 2-7(E)(2) Procedure.....61  
 Part. 2-7(F) Excavation Permit..... 61  
     Section. 2-7(F)(1) Applicability.....61  
     Section. 2-7(F)(2) Procedure.....62  
 Part. 2-7(G) Integrated Development Ordinance Approvals..... 62  
     Section. 2-7(G)(1) Applicability.....62  
     Section. 2-7(G)(2) Procedure.....62  
 Part. 2-7(H) Median Cuts and Left Turn Lane Approval..... 63  
     Section. 2-7(H)(1) Applicability.....63  
     Section. 2-7(H)(2) Procedure.....63  
     Section. 2-7(H)(3) Additional approvals.....63  
 Part. 2-7(I) Oversize, Overweight and/or Over Length Truckloads Permit... 64  
     Section. 2-7(I)(1) Applicability.....64  
     Section. 2-7(I)(2) Procedure.....64  
 Part. 2-7(J) PERMIT SO-19 (PRIVATE STORM DRAIN FACILITIES WITHIN A CITY RIGHT-OF-WAY AND/OR EASEMENT) ..... 64  
     Section. 2-7(J)(1) Applicability.....64  
     Section. 2-7(J)(2) Procedures .....64  
 Part. 2-7(K) Private Use of Fire Hydrants..... 65  
     Section. 2-7(K)(1) Applicability.....65  
     Section. 2-7(K)(2) Procedure.....65  
     Section. 2-7(K)(3) Fire Hydrant Special Use Permit, refer to the [ABCWUA's Water and Sewer Rate Ordinance](#).....66  
 Part. 2-7(L) Public Swimming Pool Operating Permit..... 66  
     Section. 2-7(L)(1) Applicability.....66  
     Section. 2-7(L)(2) Procedure.....66  
 Part. 2-7(M) Revocable Contract (Approval To Place Private Infrastructure In The Public Right-Of-Way) ..... 67  
     Section. 2-7(M)(1) Applicability.....67  
     Section. 2-7(M)(2) Procedure.....67  
 Part. 2-7(N) Sewer Tapping Permit..... 68  
     Section. 2-7(N)(1) Applicability.....68  
     Section. 2-7(N)(2) Procedure.....68  
 Part. 2-7(O) Sidewalk, Drive Pad and Curb and Gutter Permits ..... 68  
     Section. 2-7(O)(1) Applicability.....68  
     Section. 2-7(O)(2) Procedure.....68  
 Part. 2-7(P) Solar Rights Permit..... 69  
     Section. 2-7(P)(1) Applicability.....69  
     Section. 2-7(P)(2) Procedure.....69  
 Part. 2-7(Q) Stormwater Control Permit for Erosion and Sediment Control  
 70  
     Section. 2-7(Q)(1) Applicability.....70  
     Section. 2-7(Q)(2) Procedure.....70  
 Part. 2-7(R) Surface Disturbance Permit..... 70  
     Section. 2-7(R)(1) Applicability.....70  
     Section. 2-7(R)(2) Procedure.....71  
 Part. 2-7(S) Water Meter and Fire Line Application ..... 71  
     Section. 2-7(S)(1) Applicability.....71  
     Section. 2-7(S)(2) Procedure.....71



**ARTICLE 2-8 DRAINAGE AND TRANSPORTATION SUBMITTALS..... 72**

Part. 2-8(A) Drainage and Transportation Submittal Approval Procedures 72  
Part. 2-8(B) Drainage Facilities and Roadway Improvements Construction Agreement and Financial Guarantee..... 73  
Part. 2-8(C) Forms and Certificates..... 73

**ARTICLE 2-9 DPM VARIANCES ..... 74**

Part. 2-9(A) Variance to DPM Standards ..... 74  
    Section. 2-9(A)(1) Applicability ..... 74  
    Section. 2-9(A)(2) Procedure..... 74  
Part. 2-9(B) Sidewalk Variance or Waiver ..... 75  
    Section. 2-9(B)(1) Applicability:..... 75  
Part. 2-9(C) Temporary Sidewalk Deferral ..... 77  
    Section. 2-9(C)(1) Applicability..... 77  
    Section. 2-9(C)(2) Governing Regulations: ..... 77  
    Section. 2-9(C)(3) Procedure..... 77  
    Section. 2-9(C)(4) Stub Street/ Cul-de-Sac Variance..... 78  
    Section. 2-9(C)(5) Vacation Of Right-Of-Way Or Easement..... 79

## ARTICLE 2-1 DETERMINING THE APPROPRIATE PROCEDURE

Many development projects require the completion of various separate but related procedures in order to secure final approval. These procedures are described within the City's Integrated Development Ordinance (IDO) or in this Development Process Manual (DPM). [Table 2-1.1, Summary of Development Procedures](#), outlines the types of development applications authorized within the City of Albuquerque. For each development action, the table indicates what applications/permits are applicable to which actions, in which regulatory document the procedures are located, any required pre-application prerequisites, the needed application materials, and the City review body that will make a decision of the action. This table is intended to guide the user toward the appropriate development processes and the appropriate steps needed to complete them.

TABLE 2.2.1 Summary of Development Procedures

Application / Permit Type	Applicability	Procedures	Prerequisites				Application Materials	Review / Decision Authority				
			Pre-Application Review Team Meeting <sup>1</sup>	Neighborhood Meeting <sup>2</sup>	Pre-Design Conference	Other		City Staff / Zoning Enforcement Officer	Zoning Hearing Examiner	Landmarks & Urban Conservation Commission	Environmental	Development Review Board
<b>LAND USE</b>												
<b>Annexation of Land</b>	Annexation of Land requests are required for the incorporation of any new territory into the domain of the City. The City of Albuquerque cannot annex property without prior permission of the Bernalillo County Board of County Commissioners (BCC), therefore a notice of the decision from the BCC is required. An annexation request must be accompanied simultaneously by a zone map amendment which establishes City zoning on the property.	<a href="#">6-7(E), IDO</a>	X				<a href="#">Application for Annexation</a>	R			R	D
<b>Conditional Use</b>	A special exception to the Unified Development Ordinance is required for Conditional Uses, those uses enumerated as conditional in a zone per the IDO, via approval by the ZHE.	<a href="#">6-6(A), IDO</a>	X				<a href="#">Development Review Application</a>				R	D
<b>Declaratory Ruling or Zoning Certificate</b>	Declaratory Ruling or Zoning Certificate is required to verify the zoning of a property and the allowable uses from the Zoning Enforcement Officer. Upon request, the Zoning Enforcement Officer can issue a declaratory ruling as to the applicability of the IDO to the proposed development or activity.	<a href="#">6-5(B), IDO</a>					<a href="#">ZHE Special Exception Application</a>	R	D			AD
<b>Expansions of Nonconforming Use or Structure</b>	Nonconformity refers to a structure, use, lot, sign or site feature that does not conform with applicable zoning, but that did conform with applicable zoning in effect at the time it was created. A Nonconforming Status Determination is required to review the status of a use or structure that is deemed non-conforming to the regulations of the Integrated Development Ordinance.	<a href="#">6-6(C), IDO</a>	X					R				D AD
<b>Sidewalk Variance</b>	A Sidewalk Variance is required if a proposed sidewalk varies in design from Integrated Development Ordinance standards or the construction of the sidewalk is delayed until the building construction is finished or no sidewalk is planned. These sidewalk exception requests are heard and approved at a DRB hearing.	<a href="#">Part. 2-9(A), DPM</a>		X			<a href="#">Development Review Application</a>	R				D AD
<b>Variance from Development Standards, IDO</b>	A Variance from Development Standards, IDO, is required for a variation from the strict, literal application to the Integrated Development Ordinance.	<a href="#">6-6(L), 6-6(M), 6-6(N), IDO</a>	X	X			<a href="#">ZHE Special Exception Application</a>	R	D			AD
<b>Variance from Technical Standards, DPM</b>	A variance is required for a variation from the strict, literal application of the Integrated Development Ordinance.						<a href="#">Development Review Application</a>	R				D

**NOTE:** "R" = Review and Recommendation "D"= Review and Decision "AD"= Appeal Decision  
 Each application will be required to follow the specific procedures required by the City for that type of application, as set forth in the Integrated Development Ordinance, in this DPM or on the City's website.  
<sup>1</sup> Pre-Application Review Team (PRT) Procedures are located in Section 6-4(B) of the Integrated Development Ordinance  
<sup>2</sup> Neighborhood Meeting Procedures are located in Section 6-4(C) of the Integrated Development Ordinance

TABLE 2.2.1 Summary of Development Procedures

Application / Permit Type	Applicability	Procedures	Prerequisites				Application Materials	Review / Decision Authority						
			Pre-Application Review Team Meeting <sup>1</sup>	Neighborhood Meeting <sup>2</sup>	Pre-Design Conference	Other		City Staff / Zoning Enforcement Officer	Zoning Hearing Examiner	Landmarks & Urban Conservation Commission	Environmental	Development Review Board	City Council	
<b>LAND USE</b>														
<b>Zone Map Amendment</b>	A zone change that exchanges one zone classification for one or more parcels of land requires a Zone Map Amendment. As the purpose of zoning is to group compatible land uses together, zone changes require a written justification statement justifying the change using goals and policies in applicable plans. If the zone change requires a site development plan or an amendment to a Integrated Development Ordinance, additional materials and information may be needed.	<a href="#">6-7(F), IDO</a> <a href="#">6-7(G), IDO</a>	X	X				R			R		D	
<b>SITE DEVELOPMENT</b>														
<b>Construction Agreements</b>	Both public and private infrastructure improvements require a Construction Agreement between the City and the developer that outlines the process by which the construction of the infrastructure will be financed and completed.	<a href="#">Part. 2-3(C), DPM</a>					<a href="#">Agreement to Construct Public Improvements</a>	R/D						
<b>Infrastructure Design Development</b>	Private and public infrastructure improvements and Capital Improvement Projects must be approved by the Development Review Board through an Infrastructure Design Development Process.	<a href="#">Part. 2-3(B), DPM</a>			X		<a href="#">Design Development and Work Order Checklist</a>	R					D	
<b>Impact Fee Assessment</b>	Impact Fees are a charge of assessment imposed by the City on new development in order to generate revenue for funding or recouping the costs of capital improvements rationally related to new development in accordance with applicable law. Impact fees are assessed and collected during the building permit process.	<a href="#">Part. 2-3(B), DPM</a>	X				<a href="#">Fee Schedule</a>	R/D						
<b>Site Plans</b>	A Site Plan that provides detail on how the property is proposed to be developed are required for certain development. Procedures and approval depend upon the type and location of the development as outlined below.													
	Any application for development of : 1. New single- or two-family detached residential developments 2. New multi-family residential development containing 50 or fewer dwelling units in structures other than single- or two-family structures. 3. Conversions of an existing non-residential structure or use to a residential use containing 100 or fewer dwelling units. 4. New civic, institutional, commercial, or industrial development with less than 100,000 square feet of gross floor area. 5. New mixed use development that contains fewer than 75 dwelling units and less than 50,000 square feet of non-residential gross floor area. 6. Expansions of existing multi-family residential, civic, institutional, commercial, industrial, and mixed use properties that increase the number of dwelling units by 25 percent of the total originally approved number of units, or that expand non-residential gross floor area by less than 25 percent of the originally approved gross floor area.	<a href="#">6-6(G), IDO</a>					<a href="#">Development Review Application</a>	R/D					AD	
	Any application for development or redevelopment of a multi-family, civic, institutional, commercial, mixed use, or industrial property that does not qualify for consideration as a Site Plan – Administrative under <a href="#">Section 6-5(G)</a> and is not located in an NR-SU, PD, or PC zone district.	<a href="#">6-6(G), IDO</a>	X	X			<a href="#">Development Review Application</a>	R					D	AD

**NOTE:** "R" = Review and Recommendation "D" = Review and Decision "AD" = Appeal Decision

Each application will be required to follow the specific procedures required by the City for that type of application, as set forth in the Integrated Development Ordinance, in this DPM or on the City's website.

<sup>1</sup> Pre-Application Review Team (PRT) Procedures are located in Section 6-4(B) of the Integrated Development Ordinance

<sup>2</sup> Neighborhood Meeting Procedures are located in Section 6-4(C) of the Integrated Development Ordinance

TABLE 2.2.1 Summary of Development Procedures													
Application / Permit Type	Applicability	Procedures	Prerequisites				Application Materials	Review / Decision Authority					
			Pre-Application Review Team Meeting <sup>1</sup>	Neighborhood Meeting <sup>2</sup>	Pre-Design Conference	Other		City Staff / Zoning Enforcement Officer	Zoning Hearing Examiner	Landmarks & Urban Conservation Commission	Environmental	Development Review Board	City Council
<b>SITE DEVELOPMENT</b>													
<b>EPC</b>	Any application for development or redevelopment of a multi-family, civic, institutional, commercial, mixed use, or industrial property within an NR-SU, PC, or PD zone districts that does not qualify for consideration as a Site Plan - Administrative under <b>Section 5-5.1F of the IDO</b> .	<u>6-6(H), IDO</u>	X	X			<u>Development Review Application</u>	R			D		AD
<b>Subdivision of Land</b>	A request of subdivision is required for the act of subdividing, or a portion of land divided into lots for real-estate development.	<u>6-6(I), IDO</u>					<u>Development Review Application</u>	R				D	AD
<b>Minor</b>	Subdivision actions that divide a tract of land into ten or fewer parcels without significant infrastructure requires a Minor site plan for subdivision.												
<b>Major</b>	Subdivision actions that creates more than ten lots and/or requires significant infrastructure require a major site plan for subdivision. A platting action prepared by a NM licensed surveyor are required for Major subdivision requests.	<u>6-6(J), IDO</u>	X				<u>Development Review Application</u>	R				D	AD
<b>Vacation of Public Easement or Right-of-Way</b>	A Vacation of Public Easement or Right-of-Way is required for the partial or complete closure of the public's right to use a street or public service easement.	<u>6-6(K), IDO</u>		X			<u>Vacation Application</u>	R				D	AD
<b>Work Order</b>	A Work Order refers to the project documentation bearing the City Engineer's authorization to construct infrastructure improvements. The Design Review and Construction (DRC) Section of the Planning Department issues private development construction Work Order for public infrastructure and perform oversight inspections. No construction can be initiated without an approved Work Order.	<u>Part. 2-3(D), DPM</u>						R/D DRC					
<b>BUILDING / CONSTRUCTION</b>													
<b>Certificate of Appropriateness</b>	An historic Certificate of Appropriateness is required for all exterior alterations, building additions, new construction, demolition, erection of fences, and placement of manufactured or pre-built structures in all designated Historic Overlay Zones before any work can begin.	<u>6-5(D), IDO</u>					<u>Development/ Plan Review Application</u>	R		D			AD
<b>Air Contaminant Source Registration</b>	Air Contaminant Source Registration is required for the operation of a commercial or industrial stationary source with actual emissions of more than two thousand pounds of any air contaminant per year or any amount of a hazardous air pollutant.	<u>PART. 2-7(A), DPM</u>	X			X <sup>3</sup>	<u>Certificate of Registration Form</u>	R/D					
<b>Authority to Construct Permit</b>	An Authority to Construct Permit is required for the construction or modification of any commercial or industrial structure which, if it were uncontrolled, would result in an emission of air contaminants greater than ten pounds per hour or twenty-five tons per year (except five tons per year for lead; ten tons per year for hazardous air pollutants).	<u>PART. 2-7(B), DPM</u>	X					R/D					
<b>Barricade Permit</b>	A Barricade Permit is required prior to excavation of any accepted City right-of-way including the setback area or when construction or demolition work interferes with vehicular or pedestrian traffic. Currently, Barricade Permit are not required for work in previously unimproved City streets or rights-of-way; however, the construction zone is required to be barricaded in accordance with the requirements of the Traffic Code.	<u>Part. 2-7(C), DPM</u>	X					R/D					AD
<b>Blasting Permit</b>	A Blasting Permit is required for all blasting work within the City Limits issued by the Albuquerque Police Department. Applicants for a Blasting Permit must present a Certificate of Insurance for \$500,000/1,000,000,/500,000 combined incident liability, structure damage, bodily injury and property damage.	<u>Part. 2-7(D), DPM</u>					<u>Blasting Permit Form</u>	R/D					

**NOTE:** "R" = Review and Recommendation "D"= Review and Decision "AD"= Appeal Decision  
 Each application will be required to follow the specific procedures required by the City for that type of application, as set forth in the Integrated Development Ordinance, in this DPM or on the City's website.  
<sup>1</sup> Pre-Application Review Team (PRT) Procedures are located in Section 6-4(B) of the Integrated Development Ordinance  
<sup>2</sup> Neighborhood Meeting Procedures are located in Section 6-4(C) of the Integrated Development Ordinance

TABLE 2.2.1 Summary of Development Procedures

Application / Permit Type	Applicability	Procedures	Prerequisites				Application Materials	Review / Decision Authority				
			Pre-Application Review Team Meeting <sup>1</sup>	Neighborhood Meeting <sup>2</sup>	Pre-Design Conference	Other		City Staff / Zoning Enforcement Officer	Zoning Hearing Examiner	Landmarks & Urban Conservation Commission	Environmental	Development Review Board
<b>BUILDING / CONSTRUCTION</b>												
<b>Demolition Permit</b>	A Demolition Permit is required for demolition work on any commercial building or residential building containing five or more dwelling units requires an Asbestos Demolition/Renovation Notification to be filed with the Environmental Health Department a minimum of ten working days prior to the start of the demolition. Note: Notification of Demolition or Renovation is also required for residential buildings that are demolished for the purposes of building non-residential structures.	<a href="#">PART. 2-6(A), DPM</a>					<a href="#">Demolition Permit Application</a>	R/D				AD
<b>Elevator Permit</b>	An Elevator Permit is required for the installation of all elevators.	<a href="#">2-6, DPM</a>					<a href="#">Elevator Permit Application</a>	R/D				
<b>Encroachment Contract</b>	The execution of an Encroachment Contract between the City and the property owner is required for the proposed construction of walls, fences and/or footings in the public right-of-way to allow private use of public right-of-way on a conditioned, revocable basis.	<a href="#">Part. 2-7(E), DPM</a>					<a href="#">Real Property Encroachment Agreement</a>	R/D				
<b>Excavation Permit</b>	An Excavation Permit issued by the City Engineer is required for excavation within the public right-of-way. Applicants for Excavation Permits should obtain a Barricade Permit from the Construction Coordination Division prior to application if the excavation work is within an accepted City right-of-way.	<a href="#">Part. 2-7(F), DPM</a>					<a href="#">Excavation Permit Application</a>	R/D				
<b>Fence or Wall Permit</b>	A Fence, Wall, or Sign Permit is required to build a fence, wall or sign, unless the provisions of Integrated Development Ordinance indicate that a permit is not required for that type of fence, wall, or sign.	<a href="#">6-5(C), IDO</a> <a href="#">Part. 2-6(H), DPM</a>					<a href="#">Wall Permit Application</a> <a href="#">Sign Permit Application</a>	R/D				
<b>Fire Repair Permit</b>	A Fire Repair Permit is required for all restoration work following a fire.	<a href="#">Part. 2-5(C), DPM</a>						R/D				
<b>Foundation Only Permit</b>	A Foundation Only Permit is required for the construction of footings, foundation walls and any other construction up to and including a first floor slab upon approval of required plans and application material.	<a href="#">Part. 2-6(C), DPM</a>					<a href="#">Foundation Permit Application</a>	R/D				
<b>Grading, Drainage, or Paving Permit</b>	A Grading Permit is required for all grading of 1.0 acre or more or 500 cubic yards and any grading to be done within or adjacent to a watercourse (defined as a major facility) during the months of July, August or September. Paving an area larger than 1000 square feet requires a Paving Permit. Repaving of existing paved areas in which no grading is planned is excluded. Note: Grading and Paving Permits are not required when the proposed grading and paving are a part of a Building Permit.	<a href="#">5-5.1.D, IDO</a> <a href="#">Part. 2-6(D), DPM</a>					<a href="#">Grading Permit</a>	R/D				
<b>Median cuts and left turn lane approval</b>	Proposed median cuts and left turn lanes require City approval to insure that spacing requirements, the type of development, internal circulation and existing or projected traffic operating conditions are considered. In addition, the location and design of median cuts in streets which are a part of the State Highway System require approval of the State Highway Department.	<a href="#">Part. 2-7(H), DPM</a>						R/D				
<b>Oversize, Overweight and/or over length truckloads permit</b>	The movement or operation of oversize, overweight and/or over length vehicles on City streets requires an oversize, overweight and/or over length truckloads permit issued by the City's Construction Coordination Division. The New Mexico Vehicle Laws, <a href="#">Section 64- 23-13 through 64-23-20</a> , define the dimensions and weight of vehicles which require this permit.	<a href="#">Part. 2-7(I), DPM</a>					<a href="#">Oversize, Overweight and/or Overlength Truckloads Permit Application</a>	R/D				
<b>Plumbing and Electrical Permit</b>	Plumbing and Electrical Permits are required to install, replace, or repair electrical, mechanical, plumbing fixtures or systems.	<a href="#">PART. 2-6(E), DPM</a>					<a href="#">Plumbing Permit Application</a> <a href="#">Electrical Permit Application</a>	R/D				

**NOTE:** "R" = Review and Recommendation "D"= Review and Decision "AD"= Appeal Decision  
 Each application will be required to follow the specific procedures required by the City for that type of application, as set forth in the Integrated Development Ordinance, in this DPM or on the City's website.  
<sup>1</sup> Pre-Application Review Team (PRT) Procedures are located in Section 6-4(B) of the Integrated Development Ordinance  
<sup>2</sup> Neighborhood Meeting Procedures are located in Section 6-4(C) of the Integrated Development Ordinance



TABLE 2.2.1 Summary of Development Procedures

Application / Permit Type	Applicability	Procedures	Prerequisites				Application Materials	Review / Decision Authority					
			Pre-Application Review Team Meeting <sup>1</sup>	Neighborhood Meeting <sup>2</sup>	Pre-Design Conference	Other		City Staff / Zoning Enforcement Officer	Zoning Hearing Examiner	Landmarks & Urban Conservation Commission	Environmental	Development Review Board	City Council
<b>LAND USE</b>													
<b>Private use of fire hydrant permit</b>	Connections to fire hydrants at any location are prohibited without written permit from the Albuquerque Bernalillo County Water Utility Authority (ABCWUA) except for City of Albuquerque street sweepers, street rollers and Fire Department vehicles. All other private and governmental users - federal, state, county, city and military - must have a permit. A Designated Permit allows the permit holder to use any of approximately twenty-nine (29) designated hydrants located within the City and County limits. A Special Permit is required for private use of other fire hydrants not noted above.	<a href="#">Part. 2-7(K), DPM</a>					<a href="#">Designated Permit Application</a> <a href="#">Special Permit Application</a>	R/D					
<b>Public swimming pool operating permit</b>	The design, construction, maintenance, and operation of public swimming pools is regulated and requires Swimming Pool Permit.	<a href="#">Part. 2-7(L), DPM</a>					<a href="#">Pool Operator Certification</a>	R/D					
<b>Public, Commercial &amp; Multi-Family Building Permit</b>	All new construction requires a building permit and may also require other permits for electrical wiring, plumbing, mechanical and so forth. For Residential Development, check with Building and Safety for appropriate procedures.	<a href="#">Article 2-5, DPM</a>						R/D					
<b>Relocation of Existing Building Permit</b>	The relocation of an existing building requires the determination of necessary modifications to meet technical codes, a foundation permit, remodeling permit, and electrical, plumbing and mechanical permits, as appropriate.	<a href="#">PART. 2-6(F) DPM</a>						R/D					
<b>Sewer Tapping Permit</b>	A Sewer Tapping Permit is required to tap into existing sewer lines.	<a href="#">Part. 2-7(N), DPM</a>					<a href="#">Request Letter, ABCWUA</a>	R/D					
<b>Sidewalk, Drive Pad and Curb and Gutter Permit</b>	Any work within the City's City right-of-way requires a permit and stipulates whom can conduct the work.	<a href="#">Part. 2-7(O), DPM</a>						R/D					
<b>Sign Permit</b>	A Sign Permit is required to erect a sign, unless the provisions of Integrated Development Ordinance indicate that a permit is not required for that type of fence, wall, or sign.	<a href="#">6-5(F), IDO</a> <a href="#">PART. 2-6(G), DPM</a>					<a href="#">Wall Permit Application</a> <a href="#">Sign Permit Application</a>	R/D					
<b>Solar Rights Permit</b>	A solar right permit is required to define and regulate the spatial and temporal limits of a property's solar right.	<a href="#">Part. 2-7(P), DPM</a>						R/D					
<b>Surface Disturbance Permit</b>	A Surface Disturbance Permit is required for all jobs that will disturb or remove soil from an area larger than three-quarters (¾) of one acre or placement of soil on an area larger than three-quarters (¾) of one acre.	<a href="#">6-5(H), IDO</a> <a href="#">Part. 2-7(R), DPM</a>					<a href="#">Fugitive Dust Construction</a> <a href="#">Fugitive Dust Programmatic</a>	R/D					
<b>Water Meter and Fire Line Application</b>	A Water Meter and Fire Line Application is required for the installation of the public portion of the water service line, including the meter and box,	<a href="#">Part. 2-7(S), DPM</a>					<a href="#">Application for the Fire Hydrant Meter Permit</a>	R/D					
<b>Wireless Telecommunication Facility Permit</b>	A Wireless Telecommunication Facility Permit or Waiver are required to comply with  Free-Standing Wireless Telecommunications Facilities (WTFs) and Architecturally Integrated Wireless Telecommunications Facilities regulations as outlined in the IDO.												
<b>Permit</b>	The erection of new freestanding or attached wireless telecommunications facilities as primary or accessory uses of land, including collocations of new facilities on existing WTF structures, requires a Wireless Telecommunications Permit.	<a href="#">6-5(K), IDO</a>					<a href="#">WTF application checklist</a> <a href="#">P (6) WTF application requirements</a>	R/D					AD
<b>Wavier</b>	Deviations from the wireless telecommunications regulations applicable to the erection or installation of a Wireless Telecommunications Facility under the IDO must obtain a Wireless Telecommunications Facility Waiver.	<a href="#">6-6(O), IDO</a>					<a href="#">Wireless Telecommunications Facility Wavier Application</a>	R				D	AD

**NOTE:** "R" = Review and Recommendation "D" = Review and Decision "AD" = Appeal Decision  
 Each application will be required to follow the specific procedures required by the City for that type of application, as set forth in the Integrated Development Ordinance, in this DPM or on the City's website.  
<sup>1</sup> Pre-Application Review Team (PRT) Procedures are located in Section 6-4(B) of the Integrated Development Ordinance  
<sup>2</sup> Neighborhood Meeting Procedures are located in Section 6-4(C) of the Integrated Development Ordinance

## ARTICLE 2-2 SUBDIVISION OF LAND

The subdivision of land within the platting and planning jurisdiction of Albuquerque is generally controlled by the [Albuquerque/Bernalillo County Comprehensive Plan](#) and specifically regulated by the Integrated Development Ordinance (IDO). Application materials for the various phases of subdividing and procedures for subdividing non-compliant parcels are found in this section of the DPM.

### Part. 2-2(A) Governing Regulations

Subdivision standards are regulated by the Section 14-16-5-4 of the Integrated Development Ordinance (IDO). The General Procedures in Section 14-16-6-4 and the application specific procedures in Section 14-16-6-6 apply to all subdivision requests. [Section 5](#) of this DPM outlines the procedures for parcels that are deemed non-compliant while [Section. 2-2\(B\)\(2\)](#) outlines the required application materials for all subdivision activities.

### Part. 2-2(B) Standard Subdivision Procedure

#### Section. 2-2(B)(1) Applicability

All subdivisions of land into 2 or more parcels, building sites, tracts, or lots, or when 2 or more platted lots are consolidated into a larger lot for development or redevelopment are governed by the Section 14-16-5-4 of the IDO.

#### Section. 2-2(B)(2) Required Application Materials

##### 2-2(B)(2)(i) [Sketch Plat](#)

1. The applicant shall submit the materials listed on the [Sketch Plat Checklist](#) to Development and Building Services.

##### 2-2(B)(2)(ii) [Preliminary Plat](#)

1. The applicant submits the materials listed on the [Preliminary Plat Checklist](#) to Development and Building Services.
2. If the parcel to be subdivided is a Non-Compliant Applicant Parcel as defined in [Section. 2-2\(C\)\(1\)](#), the proposed location of any easements on the Non-Compliant Applicant Parcel necessary for any overhead or underground utilities serving the Non-Compliant Adjacent Parcel(s), and the proposed location of any easements on the Non-Compliant Applicant Parcel necessary for access to and from the Non-Compliant Adjacent Parcel(s) should be shown on the Preliminary Plat (See [Section. 2-2\(C\)\(2\)](#)).

##### 2-2(B)(2)(iii) [Final Plat](#)

1. The applicant shall submit the materials listed on the Final Plat Checklist to Development and Building Services.



## **Part. 2-2(C) Non-Compliant Parcel Procedure**

### **Section. 2-2(C)(1) Applicability**

Part. 2-2(C) applies to Non-Compliant Parcel(s) which meets one of the following conditions and which is the basis of a subdivision request:

- a. *The parcel was created by metes and bounds description or by plat prior to the effective date of the City of Albuquerque's Subdivision Ordinance, or created after the effective date of the City of Albuquerque's Subdivision Ordinance without complying with the requirements thereof;*
- b. *Shares a boundary with a Non-Compliant Adjacent Parcel; and*
- c. *Was a part of a larger parcel of land that included the Non-Compliant Adjacent Parcel.*

It is the policy of the City of Albuquerque that where a parcel proposed to be subdivided is a Non-Compliant Applicant Parcel, any Non-Compliant Adjacent Parcel be included as a part of the proposed subdivision.

### **Section. 2-2(C)(2) Procedures**

1. If the parcel proposed for subdivision is a Non-Compliant Applicant Parcel, the Planning Division planner should familiarize the subdivider with the Non-Compliant Procedure at the Pre-Application discussion.
2. The applicant/subdivider of a Non-Compliant Applicant Parcel shall demonstrate at or prior to the Development Review Board hearing that the applicant/subdivider has notified the owner of the Non-Compliant Adjacent Parcel by certified mail, return receipt requested, of the subdivider's intention to subdivide the parcel and requesting the participation in the subdivision process by the owner of the Non-Compliant Adjacent Parcel, and that the owner of the Non-Compliant Adjacent Parcel has failed or refused to participate (without compensation from the owner of the Non-Compliant Applicant Parcel).
3. In the event that the Applicant/subdivider has demonstrated compliance with Section 2-2(C)(2).2 above, the Development Review Board shall proceed with the subdivision without the participation of the owner of the Non-Compliant Adjacent Parcel without including the Non-Compliant Adjacent Parcel as part of the platting process and without requiring the signature of the owner of the Non-Compliant Adjacent Parcel on the plat.
4. The proposed location of any easements on the Non-Compliant Applicant Parcel necessary for any overhead or underground utilities serving the Non-Compliant Adjacent Parcel(s), and the proposed location of any easements on the Non-Compliant Applicant Parcel necessary for access to and from the Non-Compliant Adjacent Parcel(s) should be shown on the Preliminary Plat. Any Non-Compliant Adjacent Parcel(s) shall be labeled "Not a Part" on the plat.

## **Part. 2-2(D) Bulk Land Subdivision Variance Criteria**

### **Section. 2-2(D)(1) Applicability**

*Part. 2-2(D)* applies to bulk land subdivision of property that is primarily intended to facilitate transfer to intermediate land holders, not to create parcels available for development without further subdivision approvals, and are requesting a variance from the DRB.

### **Section. 2-2(D)(2) Bulk Land Subdivision Variance Criteria**

Where a Variance is requested based on a bulk land subdivision, the Development Review Board must find the following conditions to apply:

- a. *Parcels zoned for single family and/or townhouse use must be larger than five acres.*
- b. *Parcels zoned for multi-family apartment or non-residential use must be larger than 40 acres.*

### **Section. 2-2(D)(3) Bulk Land Subdivision Variance Procedure**

Bulk land subdivision variance procedures are located in Section 14-16-6-6(L) of the IDO.

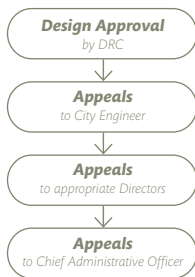
# ARTICLE 2-3 PUBLIC INFRASTRUCTURE IMPROVEMENT PROCEDURES

Article 2-3, outlines the procedures for design development, approval, and construction of Infrastructure Improvements and City Capital Improvement projects. The process is generalized to accommodate both Capital Improvement Projects (CIP) and Private Developer Projects.

## FUNDAMENTALS

Features of approved designs must address requirements established by the Development Review Board (DRB).

Designs must be reviewed and approved by the City Engineer and staff of other City offices concerned with infrastructure and Capital Improvements Projects. Approval of the design is obtained from the DRC; appeal to the City Engineer; appeal to appropriate Group Directors; appeal to Chief Administrative Officer.



The City will not accept maintenance responsibility unless all construction is warranted in accordance with the [Integrated Development Ordinance \(IDO\)](#) requirements and the City of Albuquerque Standard Specifications for Public Works Construction, (Standard Specifications) current edition.

City's final acceptance of a project requires completed construction in accordance with approved plans and specifications along with any approved revisions. It also requires submittal of acceptable, reproducible, As-Built drawings of the work (see [Part. 2-3\(D\), Work Orders](#)), and payment of all outstanding fees and permits. All necessary easements, covenants and licenses must also be completed prior to acceptance. Capital Improvement Projects will follow contract requirements in regards to final acceptance.

In general, infrastructure required for a private development project within public right-of-way shall be shown in the DRC Plans. If an infrastructure list was generated at DRB, DRC Plans shall be generated to show construction of items on the approved infrastructure list. Various types of procedures involving an Agreement between the Private Developer and the City include:

### “Procedure A”:

A procedure by which a developer constructs public infrastructure improvements by a City-approved contractor of the developer’s own choice as part of a site plan or platting action.

### “Procedure B”:

A procedure by which a developer constructs required public and/or private infrastructure improvements shown on an infrastructure list by a City-approved contractor of the developer’s choice; improvements are required as a result of a site plan or platting action which requires either financial guarantee or construction prior to platting or site plan approval.

### “Procedure C”:

A procedure by which the City constructs public infrastructure improvements; these improvements may be wholly funded by the developer(s). Contract administration is by the City. Private funds must be received prior to contracting the work.

### “Procedure C” (Modified):

A procedure by which the City constructs public infrastructure improvements; these improvements may be only partially funded by developer(s). These include deferred items (contributions for sidewalks, traffic signals, intersection improvements, etc.), 50/50 contributions and no adjustments are made after the construction. Contract administration is by the City. Private funds must be received prior to contracting the work.

## Part. 2-3(A) Governing regulations

Plans for infrastructure improvements must be prepared according to the ordinances and policies listed in the [Infrastructure Improvements Governing Regulations Summary](#), found on the City of Albuquerque website. Also follow policies, where applicable, from other government agencies including, but not limited to AMAFCA, EPA, OSHA, NMDOT, and AASHTO.

**PRE-DESIGN PHASE  
(OPTIONAL)**

For complex development projects, it is recommended to consider beginning this phase after the Development Review Board review of the Sketch Plat and submittal of the Conceptual Grading and Drainage Plan. (See the [IDO](#) for subdivision regulation and [Chapter 6](#)

[Drainage, Flood Control and Erosion Control](#))

For less complicated development projects, the pre-design phase may begin after DRB approval of Preliminary Plat or Site Plan approval. Capital Improvements Projects shall be governed by contractual Agreements.

## **Part. 2-3(B) Infrastructure Design Development Procedure**

### **Section. 2-3(B)(1) Applicability**

Part. 2-3(B) outlines the procedures for design development of Infrastructure Improvements and City Capital Improvement projects.

### **Section. 2-3(B)(2) Procedure**

Prior to making a submittal to the DRC, the applicant shall coordinate with the DRC Chair to determine whether the work order requires a full work order, a non-IIA work order, or a ABCWUA mini work order. A full work order shall be needed for any substantial work within City right-of-way. A City non-IIA work order may be allowed for work within City right-of-way which involves very minimal impact to city-owned facilities, such as a few required utility connections on a major street from a new building facility.

Applicants can request special permission from the DRC Chair to submit a project through the non-IIA work order process. However, all projects that have associated infrastructure lists shall require review through the full work order process.

A project may be defined as a ABCWUA mini work order if there are no water main or sewer line extensions involved in the project, and all that is required are utility connections to existing facilities within a street classified as either a major local or residential roadway. A connection that would normally require a tapping permit can be included in the ABCWUA mini work order process. In this case, the applicant shall coordinate with ABCWUA directly and no formal DRC submittal shall be required.

#### **2-3(B)(2)(i) [Pre-Design Conference](#)**

1. In cases when a DRC applicant is unsure of infrastructure requirements or DRC process, the applicant may choose to request a Pre-Design Conference. A Pre-Design Conference allows the developer, Consulting Engineer, DRC members, and other City staff to discuss detailed design requirements, the Consulting Engineer's approach to implementing DRB infrastructure requirements and the subsequent design and review procedures.
2. To schedule a Pre-Design Conference, the applicant submits all application materials indicated on the [Full Work Order or City Non-IIA Work Order Process Checklist](#) to the DRC Coordinator.
3. Upon receiving the application, the DRC Coordinator shall:
  - a. Review application material for completeness. If insufficient, developer is notified of additional requirements.
  - b. Schedule the Pre-Design Conference for DRC meeting.
  - c. Assign the project number, unless previously assigned.
  - d. Start a project file.
4. Complete submittals will be placed on the agenda and a DRC meeting will be held within three (3) to ten (10) working days depending upon project complexity, DRC workload, and schedule availability.

DESIGN AND REVIEW PHASE

2-3(B)(2)(ii) Design Development

1. The Consulting Engineer prepares plans incorporating any required materials into the infrastructure design.
2. Construction Plans and Specifications must be prepared in accordance with current Standard Specifications unless otherwise approved by the DRC.
3. Format and content of plan sets shall follow [Chapter 4 Construction Plan Standards](#).

2-3(B)(2)(iii) Preliminary Design Review (30, 60 or 90% complete plans) by DRC and Other City Offices

1. Applicant shall determine plan completion percentage for preliminary submittal based on complexity of project.
2. The applicant submits all required material listed on the Design Review Committee Submittal Requirements for [Full Work Order](#) or [City Non-IIA Work Order Checklist](#) to the DRC for a preliminary design review.
3. Upon receiving the application, the DRC Coordinator shall:
  - a. *Check for the completeness of submittal and notify applicant of any missing items; hold until submittal is complete or reject submittal, if appropriate.*
  - b. *Update project file.*
  - c. *Schedule a comment review meeting for DRC to present combined comments to the Consulting Engineer.*
  - d. *Distribute the plan sets, transmittal letter and other required material to appropriate city departments for review.*
  - e. *Notify the Consulting Engineer of scheduled comment review meeting.*
4. The DRC Chair shall:
  - a. *Review plans for quality and content. If the submittal is unacceptable, areas of major concern are identified and the submittal is returned to the Consulting Engineer for correction.*
  - b. *Identify items to be distributed with plans to the necessary City Departments and government review agencies, noting any special distribution (e.g., AMAFCA, Parks and Recreation, Traffic Operations, etc.).*
  - c. *Specify review time based on complexity of project and current staff workload, a minimum of three (3) and typically a maximum of fourteen (14) working days between submittal and scheduled meeting.*
5. A DRC Comment Review Meeting shall be conducted as a forum to discuss the concerns submitted from the DRC members and the various review agencies. The DRC's comments will be documented briefly on the meeting minutes, and remaining comments will be documented as mark ups on the plans. Meeting minutes shall then be distributed to all DRC members and the Consulting Engineer.

2-3(B)(2)(iv) Incorporation of Comments and Preparation of Final Plans

1. Following the Preliminary Design Review, the Consulting Engineer must either incorporate the City review comments into the proposed final plans or propose acceptable alternatives.

### 2-3(B)(2)(v) Final Plans (90 to 100% complete plans) and Estimate Sheet of Infrastructure Improvements Review

1. The Consulting Engineer submits the materials listed on the Design Review Committee Submittal Requirements for *Full Work Order Checklist* or the *City Non-IIA Work Order Checklist* to the DRC Coordinator. The complete package of required submittals must be received prior to being scheduled for a DRC meeting.
2. Upon receiving the submittal, the DRC Coordinator shall verify its completeness.
3. If complete, the submittal is reviewed with DRC Chair in order to schedule the DRC meeting.
4. The DRC Coordinator shall then schedule the DRC meeting within three (3) to fourteen (14) working days of receipt of the completed submittal, depending upon project complexity and DRC workload.
5. After the DRC meeting is scheduled, the DRC Coordinator shall:
  - a. *Distribute the plans, estimate, construction plan comments and/or marked-up plans to the DRC members for review, with notice of scheduling for DRC.*
  - b. *Notify the Consulting Engineer of scheduled DRC meeting with final plans.*
  - c. *If applicable, complete the request for Determination of Outstanding Pro-Rata Charges for Water & Sanitary Sewer from the ABCWUA.*
6. The DRC Chair shall:
  - a. *Review final plans for compliance with review comments.*
  - b. *Conduct the DRC meeting as a forum for discussion of final review comments.*
  - c. *Take notes and collect comments made by committee members. Comments should be made in written form, but are usually provided on marked up plans.*
  - d. *Document any remaining concerns and distribute meeting minutes to all DRC members and Consulting Engineer.*
7. The DRC Chair shall verify that any necessary easements are recorded.

### 2-3(B)(2)(vi) Establishment of Pro-Rata

1. If the project included public water and/or sanitary sewer work and it has been determined that pro-rata will be generated, the Developer may complete the *Pro-Rata Statement* requesting establishment of pro-rata. The following process is initiated after the Developer identifies the parcels to be assessed:
  - a. *The Administrative Assistant, Construction Management Division sends the project file, with final payment application that is applicable to the ABCWUA facilities.*
  - b. *The ABCWUA Utility Development Section staff calculates the preliminary pro-rated value of improvements to adjacent parcels of land in accordance with the public water and public sanitary sewer improvement only and the ABCWUA Water and Wastewater System Expansion Ordinance. (Final pro-rata will be determined by the contractor's final invoice.)*

APPROVAL / SIGNATURE  
PHASE

2-3(B)(2)(vii) Preparation of Plans and Estimate for Approval Signatures.

1. ABCWUA approval of construction plans is contingent upon the ABCWUA approved Development Agreement, payment of outstanding pro-rata, and executed availability statement and serviceability letter.
2. The Consulting Engineer shall make any necessary final corrections on document(s).
3. Revised plans bearing Engineer's seal, signature, and date are to be submitted to the DRC Coordinator. The submittal shall include sets of prints if requested by the minutes of the final DRC meeting.
4. The Consulting Engineer uses the Estimate Sheet for Infrastructure Improvements to prepare an estimate of the quantities of materials for the project. The Estimate Sheet of Infrastructure Improvements shall incorporate all public infrastructure to be built as part of the plan set.

2-3(B)(2)(viii) Final Approval of Plans and Estimate

1. Upon receiving the sealed plans, the DRC Coordinator verifies the completeness of submittal.
2. If a Signature Session was required per the DRC's meeting notes, the DRC Coordinator schedules a DRC Signature Session meeting. Signature session occurs three (3) to fourteen (14) working days between submittal and scheduled meeting as the workload permits. If a Signature Meeting was not required the original plans are routed for DRC member's signatures.
3. The DRC Chair verifies that the corrections requested by DRC were incorporated, if applicable.
4. After all signatures are affixed, the Chair shall review the design package for completeness and sign Estimate Sheet of Infrastructure Improvements and original plans. The signed plans and estimate sheet are forwarded to the DRC Coordinator.
5. The Approval is valid for a period of one (1) year, after which resubmittal and approval of any revisions is required prior to Work Order issuance.



**INFRASTRUCTURE DESIGN DEVELOPMENT**

**PRE-DESIGN PHASE**

During this phase, all arrangements required to complete the construction contract between the developer and the contractor, or City and contractor, are identified.

**1 Pre-Design Conference (optional)** are available for applicants whom unsure of infrastructure requirements or the DRC process.

**DESIGN AND REVIEW PHASE**

**2 Design Development.** The Consulting Engineer prepares Construction Plans and Specifications of the infrastructure design.

**3 Preliminary Work Order Submittal.** The applicant submits all required material listed on the Design Review Committee *Full Work Order or City Non-IIA-Work Order Checklist* to the DRC for a preliminary design review.

**4 Preliminary Design Review.** A DRC Comment Review Meeting is conducted as a forum to discuss the project concerns from the DRC members and the various review agencies.

**5 Mark ups are returned to applicant.** The DRC's concerns will be documented as mark ups on the plans, which will be distributed to the Consulting Engineer.

**6 Preparation of Final Plans.** The Consulting Engineer either incorporates the City review comments into the final plans or proposes acceptable alternatives.

**5 Final Plan Submittal.** The DRC's concerns will be documented as mark ups on the plans, which will be distributed to the Consulting Engineer.

**6 Preparation of Final Plans.** The Consulting Engineer either incorporates the City review comments into the final plans or proposes acceptable alternatives. The Consulting Engineer also uses the Estimate Sheet for Infrastructure Improvements to prepare an estimate of the quantities of materials for the project.

**7 Final Plan Submittal.** The Consulting Engineer submits the materials listed on the *Design Review Committee Submittal Requirements for Full Work Order Checklist* or the *City Non-IIA Work Order Checklist* to the DRC Coordinator.

**8 DRC Final Plan Review.** DRC Meeting is held to collect final review comments from all applicable review bodies.

**9 Establishment of Pro-Rata.** If the project included water and/or sanitary sewer work and it has been determined that pro-rata will be generated, the developer completes the Pro-Rata Statement requesting establishment of pro-rata.

**APPROVAL / SIGNATURE PHASE**

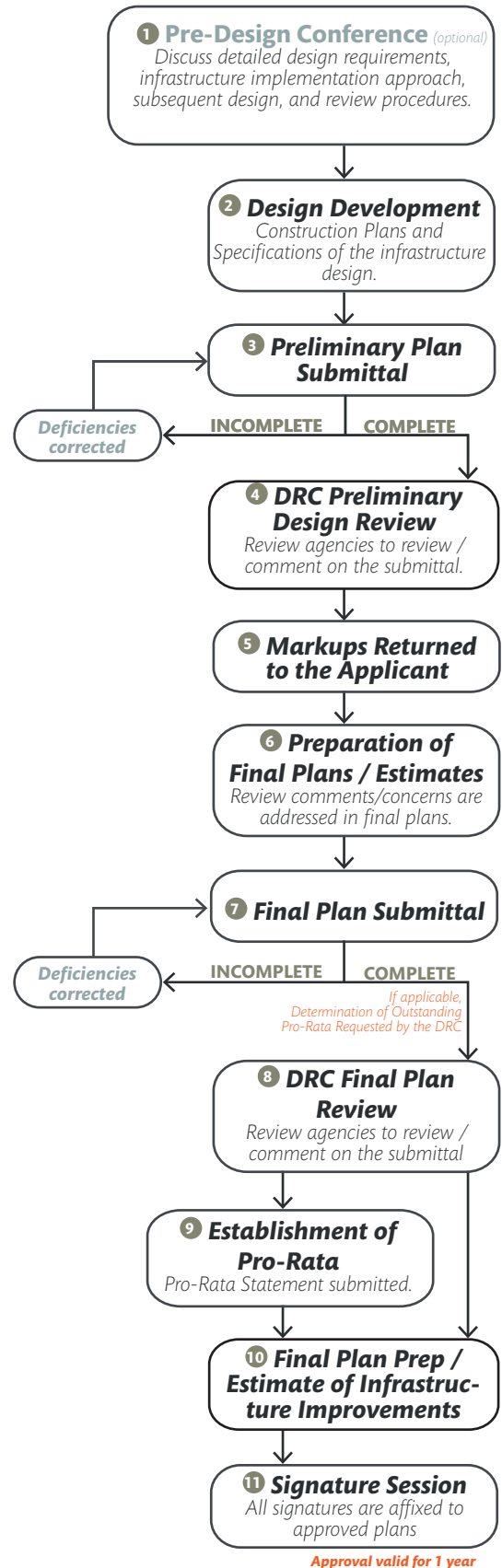
**10 Estimate of Infrastructure Improvements.** The Consulting Engineer makes any necessary final corrections on the plans and the estimate for infrastructure improvements. Revised plans bearing Engineer's seal, signature, and date are submitted to the DRC Coordinator.

**11 Signature Session.** If a Signature Session was required per the DRC's meeting notes, a DRC Signature Session meeting is held to affix all signatures onto the original plans. Otherwise, plans are routed to obtain necessary signatures. Then the DRC Chair reviews and signs the Estimate Sheet of Infrastructure Improvements.

PRE-DESIGN PHASE

DESIGN REVIEW PHASE

APPROVAL PHASE



## **Part. 2-3(C) Construction Agreements (Infrastructure Improvements Agreement - IIA)**

Part. 2-3(C), covers the required Agreement between the City and the developer relating to the process by which the construction of the infrastructure will be financed and completed. Procedures A, B, and C relate directly to standard city forms of agreement for accomplishing improvements.

“Procedure B” is used to construct infrastructure required by the DRB. A developer using a “Procedure B” Agreement for construction of improvements may also elect to have the City construct such improvements via a DMD contract (“Procedure C”). This approach may require completion of both a “Procedure C” and a “Procedure B” Agreement. However, since the developer can usually negotiate lower contract prices than the City receives in the public bid process used in “Procedure C”, it is unlikely that many developers will find this alternative attractive.

Standard deferral forms ([Sidewalk Deferral Agreements](#)) are available on the [City of Albuquerque](#) website. The [Sidewalk Deferral Agreement](#) allows the developer to delay construction of sidewalks within a subdivision until lot development. Construction of deferred sidewalks must be financially assured as provided in the [Integrated Development Ordinance](#). The process outlined for “Procedure B” in this section also applies to Sidewalk Deferral Agreements.

In accordance with City of Albuquerque requirements, the owner of a residential development may elect upon the approval of the City Engineer to choose the [Alternative Method for Construction of Sidewalks](#). In such an event, the owner shall be responsible for construction of the sidewalks, and they shall also submit a nonrefundable payment to the City for 10% of the estimated construction cost of the sidewalks. The funds received would be placed in a separate Capital Implementation Program activity in the Street Maintenance Program. The form for the Alternative Sidewalk is provided on the COA website.

Summaries of steps for processing the various Infrastructure Improvements Agreements are as follows:

### **Section. 2-3(C)(1) “Procedure a”**

#### **2-3(C)(1)(i) [Applicability](#)**

“Procedure A” applies to the construction of public infrastructure on existing right-of-way or easements without subdivision taking place, or it may apply to Site Plan requirements with financial assurance requirements or required infrastructure.

#### **2-3(C)(1)(ii) [Procedures](#)**

This section specifies the document and requirements needed to complete an Agreement to Construct Public Improvements by a City Contract.

1. The developer completes the [Agreement to Construct Public Improvements](#):

- a. The date is to be left blank as it is filled in by the City on the date of final signature.
  - b. The Agreement shall state who will inspect, survey, and test the construction.
  - c. The Agreement is to be signed by the developer and the signature is to be notarized. If the developer is not the owner of the real estate, the developer must submit satisfactory evidence of authority to execute the Infrastructure Agreement and other related documents.
2. The original Agreement shall be submitted to DRC staff, along with Work Order documents. The Work Order document process is outlined in the Work Order procedures [Part. 2-3\(D\)](#).
  3. Upon receiving the Agreement, the DRC staff will review its format and content. If acceptable, the Agreements shall be forwarded to:
    - a. City Legal for review and approval.
    - b. The City Engineer, for signature and notarization.
  4. The DRC Staff records the document at the County Clerk's Office and files the original with the City Clerk.
  5. Copies of Agreement are to be distributed to the City Project file, the Consultant, and the Developer as part of the Work Order documents (see [Part. 2-3\(D\)](#)).
  6. The signed Agreement shall become part of the Work Order document set.

## Section. 2-3(C)(2) "Procedure B"

### 2-3(C)(2)(i) [Applicability](#)

"Procedure B" applies to construction of required public and/or required private infrastructure (new subdivisions after June, 1983).

### 2-3(C)(2)(ii) [Procedures](#)

This section specifies the document and requirements needed to complete an Agreement to Construct Public and/or private infrastructure required by the DRB. Because of the number of details to be addressed, initial submittal of an unsigned draft package for City Staff review and comment is recommended.

#### 2-3(C)(2)(ii)(a) [Agreement Package](#)

1. The Developer completes the [Agreement to Construct Public and/or Private Infrastructure Improvements](#). The Agreement is to be signed and the signature is to be notarized.
2. The original Agreement, along with the DRB approved Infrastructure List is to be submitted to the DRC staff.
3. If a financial guaranty is required, an [Irrevocable Letter of Credit](#), [Escrow Letter](#), [Infrastructure Improvements Bond](#), [Loan Reserve](#), [Cashier's Check](#), or [Municipal Lien](#) are to be submitted to the DRC staff.
4. The financial guaranty shall provide that the City may demand payment from the financial guaranty issuer, commencing on the date of the construction completion deadline, and extending for a period of not less than sixty (60) days thereafter.
5. The financial guaranty must be issued by:
  - a. A federally insured financial institution; or
  - b. A surety licensed to do business in New Mexico; or
  - c. A title company authorized to do business in New Mexico.

6. A financial guarantee amount is calculated as follows:
  - a. *125% of the City's estimated cost of uncompleted required infrastructure plus 10% of the City's estimated cost of the completed work, including N.M. Gross Receipts tax, survey and inspection fees, and testing.*
7. Financial guaranty reductions will be allowed for construction projects in excess of \$150,000.00. Upon completion and Engineer's certification at one-third and two-thirds of the entire work associated with the original financial guaranty, a requested reduction of the financial guaranty may be permitted. All financial guaranty reductions shall be at the sole discretion of the City Engineer. Each reduction will release 90% of the City's estimated cost of the completed and certified work required by the financial guaranty.
8. Upon receipt, the Agreement package shall be screened by the DRC staff to verify that comments and required submittals have been incorporated. If acceptable, the package is forwarded to:
  - a. *City Legal for review and approval.*
  - b. *After Legal Department has reviewed and approved Agreement, the Agreement is to be forwarded to the City Engineer for signature and notarization.*
9. The original Agreement and Claim of Lien, if applicable, shall be recorded with the County Clerk and filed with the City Clerk.
10. Executed copies of Agreement are distributed to the City project file, consultant, and the Developer.
11. The Site Plan and/or Final plat approval will be withheld until the "Procedure B" Agreement is completed AND either a suitable financial guaranty is received by the City OR the required improvements are completed and accepted by the City.
12. If final plat is approved and recorded prior to Work Order issuance, the Developer submits a copy of the recorded plat sheet(s) to the DRC Chair to be substituted for the Preliminary Plat Sheet in the construction drawing set. If construction is to be completed before the recording of the Plat, a copy of the approved Preliminary Plat shall remain in the construction plan set during construction.
13. The signed Agreement shall become a part of the Work Order document set.

### ***2-3(C)(2)(ii)(b) Revisions to Plat, Plans, or Agreement***

1. Any significant revision to the Plat, Plat status, or the DRB Infrastructure Listing after approval of construction plans and estimates, and after filing a "Procedure B" Agreement, will require filing an Amendment. The Amendment form documents the desire by the Developer and the City to have the provisions of the original Agreement apply to the identified revisions, and provides for any necessary adjustment to the financial guaranty.
2. Any such plat and/or plan revisions must be approved by the DRB and/or DRC as appropriate. Minor revisions to the approved infrastructure list may be made on the infrastructure list with the approval of the Developer, the DRC Chairman and the appropriate DRB member(s).
3. Any proposed amendments to a filed "Procedure B" Agreement must be approved by the City Engineer and City Legal. Depending upon the nature and impact of the revision, either an amendment to the original Agreement will be filed or a completely revised Agreement may be filed to supersede the original Agreement.
4. When the Developer amends the Agreement to request Final Plat approval, when Final Plat approval was not previously requested, and a Work

Order has been issued, the Financial Guarantee amount will be calculated as follows:

- a. 125% of the City's estimated cost of uncompleted required infrastructure, plus 10% of the City's estimated cost of the completed work, including N.M. Gross Receipts tax, survey and inspection fees, and testing.

### **2-3(C)(2)(ii)(c) Extension of Time to Complete Required Infrastructure Improvements Agreements**

1. The City's Integrated Development Ordinance and the text of the Standard Agreement to Construct Infrastructure improvements provide that the required improvements shall be completed within two years of execution of the Agreement. Such period may be extended by the DRB. The conditions which indicate it is appropriate to extend the time of completion are as follows:
  - a. When the Required Infrastructure cannot be constructed until completion of publicly-funded improvements necessary to permit construction of the required infrastructure.
  - b. When the required infrastructure will not be usable initially and existing interim improvements are adequate for short term needs.
  - c. When no other development is adversely affected by the continued deferral of public improvements.
  - d. When the street pattern and development are such that only minimal need exists for immediate construction of sidewalks, a sidewalk deferral may be granted by the DRB. This deferral may be granted for a period of up to four (4) years without an extension.
2. The DRB shall not approve extensions unless it makes findings, based upon the evidence presented to it at a public meeting, that:
  - a. The extension would not be injurious to the public safety, health or welfare, or to adjacent property, the neighborhood or the community; and
  - b. The extension will not conflict significantly with the goals and provisions of any City, County, or AMAFCA adopted plan or policy, the Integrated Development Ordinance, or any other City Ordinances; and
  - c. The extension will not hinder future planning, public right-of-way acquisition, or the financing of construction of public infrastructure improvements.
3. An application for an extension beyond the original two year period must be filed at the Planning Division for review by the DRB.
4. Decision upon a completed and filed application for extension approval, for all infrastructure other than temporarily deferred sidewalks, shall be rendered after a public hearing thereon, which public hearing shall be held not later than thirty (30) days after the City has received developer's completed application materials..
  - a. Requests for extensions involving temporarily deferred sidewalks only, will not require a public hearing. Decisions on a completed and filed application for such an extension may be rendered at the next regularly scheduled meeting of the DRB.
5. The DRB shall review the extension request and supplemental material submitted. The DRB may request comments from other City departments, governmental agencies and franchised utilities as may be appropriate.
6. After the public hearing, the DRB Chair shall issue an official notice of the meeting action taken by the DRB.
7. If approved, the Developer submits to following materials to the DRC staff:
  - a. The Extension Agreement,
  - b. The notice of DRB action.





## Part. 2-3(D) Work Order(s)

Part. 2-3(D), covers the requirements for obtaining the City Engineer's authorization to construct infrastructure improvements and are required for the construction of all public infrastructure. Documentation bearing the City Engineer's authorization is required to construct infrastructure improvements.

### Section. 2-3(D)(1) Applicability

Work Orders bearing the City Engineer's authorization are required for the construction of all public infrastructure.

### Section. 2-3(D)(2) PROCEDURES

Section. 2-3(D)(2), specifies the documentation and procedures required for the issuance of a work order.

#### PRE-CONSTRUCTION PHASE FOR PRIVATE DEVELOPMENT

*During this phase, all arrangements required to complete the construction contract between the developer and the contractor, or City and contractor, are identified.*

#### 2-3(D)(2)(i) Contract Documentation

1. The Developer shall complete and submit all materials listed on the Work Order Requirements List to the DRC staff.
  - a. Upon receiving the contract documentation, the DRC staff verifies that the scope of work on the contract is same as shown on DRC approved Estimate Sheet of Infrastructure Improvements and plan set. If correct, the Agreement package is forwarded to City Legal for review and approval.
  - b. When documentation has been approved by the Legal Department, the DRC staff prepares the Work Order Issuance Checklist and calculates amount of engineering fees due.

#### 2-3(D)(2)(ii) Payment of Fees

1. Engineering fees will be calculated based upon services provided by the City, per the approved Agreement.
2. The DRC staff shall contact the developer and/or consultant to submit balance of engineering, recording, restoration, or excavation fees as applicable and to pay any outstanding ABCWUA pro-rata.
3. The Developer pays:
  - a. Any outstanding pro-rata charges to ABCWUA.
  - b. The required amount for engineering and recording, restoration, or excavation fees as applicable to the City, as applicable.

#### 2-3(D)(2)(iii) Preparation of Work Order

1. The DRC Chair confirms that all required easements and permits have been obtained and included with Work Order documents.
2. If accurate, the DRC staff:
  - a. Signs the Estimate Sheet of Infrastructure Improvements indicating that fees have been received and that the contract documentation is complete and the project is ready for issuance of Work Order.
  - b. Forwards the original plans to City Engineer for review and approval.
  - c. Makes the required number of full size, half-size copies of plans, physical and pdf copies of work order package for distribution.



**INFRASTRUCTURE IMPROVEMENTS AGREEMENT**

**SUBMITTAL PHASE**

During this phase, all arrangements required to complete the construction contract between the developer and the contractor, or City and contractor, are identified.

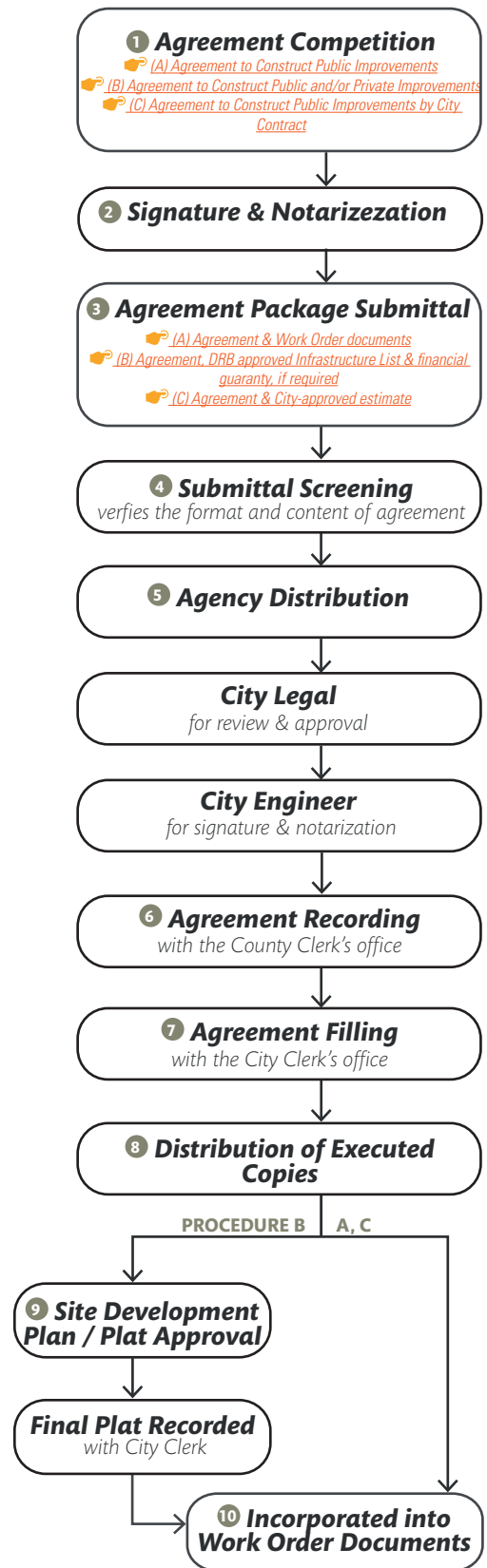
- 1 **Agreement Competition.** The developer completes the Construction Agreement pertaining to the proposed improvements; Agreement to Construct Public Improvements (A), Public and/or Private Infrastructure Improvements (B), or Public Improvements by City Contract (C). The specifics for completing Agreements A,B, or C are outlined in Section 2-4.
- 2 **Signature & Notarization.** The developer signs the agreement and gets the signature notarized.
- 3 **Agreement Package Submittal.** The developer submits the original copy of the agreement and all required supplemental materials to Project Administrator.

**REVIEW / APPROVAL PHASE**

- 4 **Submittal Screening.** The Project Administrator reviews the format and content of the agreement.
- 5 **Agency Distribution.** Once the agreement has been reviewed, the Project Administrator forwards the agreement to City Legal for review and approval and then the City Engineer for review, approval and signature.
- 6 **Agreement Recording.** Once all required signatures are obtained, the Project Administrator will record the agreement at the County Clerk's Office and file the original with the City Clerk.
- 7 **Agreement Filing.** The DRC Staff records the document at the County Clerk's Office and files the original with the City Clerk.
- 8 **Distribution of Executed Copies.** The DRC Staff distributes executed copies of Agreement to the City project file, the Consultant, and the Developer.
- 9 **Site Development Plan / Plat Approval.** Site Development Plan and/or Final plat approval will be withheld until the "Procedure B" agreement is completed AND either a suitable financial guaranty is received by the City OR the required improvements are completed and accepted by the City.
- 10 **Incorporated into Work Order Documents.** The signed Agreement becomes part of the Work Order document set.

SUBMITTAL PHASE

REVIEW / APPROVAL PHASE



- d. Makes any extra prints or copy plans that have been requested by developer or Consulting Engineer (to be billed directly to requester).
3. Upon receipt, the DRC:
  - a. Assigns a Construction Engineer, whom assigns a Construction Inspector, and
  - b. Notifies the contractor to pick up work order package.

### 2-3(D)(2)(iv) [Permit\(s\) Attainment](#)

1. The Contractor obtains all required permits noted on the [Work Order Issuance Checklist](#) and the [Estimate Sheet of Infrastructure Improvements](#). All required permits must be acquired before release of the Work Order by the Construction Management Section.
2. Once the permits are obtained, the DRC Coordinator schedules a pre-construction meeting and distributes the work order package.

### 2-3(D)(2)(v) [Pre-construction Conference](#)

The following two (2) activities may be undertaken in the order the contractor chooses. Both must be accomplished prior to the construction phase.

1. A Pre-Construction Conference is held to discuss the project schedule and any potential problems that may arise.
  - a. *The Consulting Engineer, the Contractor, the Surveyor, the Testing Lab, the Assigned Construction Engineer, the Construction Inspector, and a AB-CWUA (Albuquerque Bernalillo County Water Utility Authority) representative are required to participate in the Pre-Construction Conference.*
  - b. *Other City Departments, the City Engineer, the ABCWUA, any other applicable government agencies, and private utilities representatives may participate as appropriate.*
2. Once the Pre-Construction Conference has occurred the construction phase may begin.

## CONSTRUCTION PHASE

### 2-3(D)(2)(vi) [Surveying/Staking](#)

1. The Contractor requests the Survey/Staking work to be done by the party specified in the Agreement.
  - a. *Survey/Staking arrangements may be arranged prior to the pre-construction conference*
2. After Surveying/Staking is complete, the Surveyor submits the construction staking notes/cut sheets to the party responsible for inspection of the project, as identified in the Agreement.
3. The Inspection Agency specified in the Agreement shall review the construction staking notes/cut sheets for apparent compliance with the approved construction plans. This review is not intended to relieve the surveyor of his responsibility to properly lay out and stake the work shown on the plans.
4. Once the review is completed the Inspection Agency notifies the contractor that the survey notes/cut sheets have been reviewed.
  - a. *If errors or deficiencies are found in the surveyor's submittal, the surveyor is notified by the Inspection Agency to make necessary corrections and the contractor is advised not to begin construction until necessary corrections are made.*



- c. Upon receipt, the DRC Coordinator shall process the revisions for review and approval. All revisions will be distributed to DRC reviewers for acceptance.
  - d. If accepted, the DRC Coordinator notifies the Consulting Engineer that the revised design is approved.
  - e. After revised design is approved, the Developer:
    - i. Submits a copy of [Change Order Form](#), signed by contractor, to the DRC Coordinator;
    - ii. Submits the Consent of Surety (warranty bond) to any increase in contract amount to the DRC; and
    - iii. Pays any additional engineering fees or defers to project close out with concurrence of the DRC Chair.
  - f. The DRC Coordinator secures the approval of the DRC Chair on revised [Estimate Sheet of Infrastructure Improvements](#), including revised permit fees, [Change Order Form](#), and plans. If applicable, any additional fees are collected and the consent of surety is routed to City Legal for review and approval.
  - g. All necessary prints are made and revisions are distributed similar to the [Work Order Distribution](#).
  - h. To follow-up, the Contractor obtains any additional required permits and picks up Work Order revisions from the Construction Management Section.
2. For Capital Improvement Projects (CIPs), greater detail is provided in the Department of Municipal Development's (DMD) document [Change Order Request \(COR\) Pre-Approval Process](#), which process is summarized below:
- a. If project includes federal funding, the normal pre-approval process through the NM Department of Transportation Construction Oversight Engineer should take place prior to submitting COR to DMD.
  - b. Request change order pre-approval by submitting a written request to the DMD's Construction Services Division (CSD) including the City Project Number, project name, the current project estimated cost, reason for the COR, proposed cost for the COR, and the proposed funding information (e.g., activity number). If the project is federally funded, include their approval or disapproval. Include any e-mail correspondence or the future custom pre-approval report with the request.
  - c. Pre-approval may be accomplished initially via e-mail correspondence. This is an interim measure until a custom web-based interface is built to handle the pre-approval requests.
  - d. Once pre-approval is obtained, the Project Manager will provide written approval to the contractor to proceed with the change order.

### 2-3(D)(2)(ix) [Pre-Final Inspection](#)

1. The Inspector, consulting engineer, and the Contractor conduct a pre-final inspection to determine if the work is ready for final inspection.
  - a. If project is ready for final inspection for a capital improvements project, the CSD Construction Engineer notifies all involved parties. For private development projects, the consulting engineer notifies all involved parties.
  - b. Otherwise, if project is not ready for final inspection, the Contractor must complete necessary work prior to scheduling final inspection.

### 2-3(D)(2)(x) [ABCWUA Final Inspection](#)

1. The Inspector completes pre-final inspection (See [Section 2-3\(D\)\(2\)\(ix\)](#)) and recommends final inspection to construction engineer.
2. A final inspection is scheduled with the Contractor, Consulting Engineer, the Developer, all city staff concerned with the project, and other government agencies as applicable.
3. At final inspection, a list of discrepancies (punch list) is prepared by the Consulting Engineer (for private development projects) or CSD (for CIPs) which is given to the Contractor for correction. A copy is sent to the Developer, the Consulting Engineer, and city staff concerned with the project.
4. A markup of as-built plans are required by the final inspection meeting for private development projects.
5. The Contractor shall correct all discrepancies (punch-list items). When the work is complete, the Contractor notifies the Inspector(s) that the work is ready for verification.
6. The Inspector verifies that discrepancies are corrected.
7. The Contractor sends the Inspector final quantities sheet and invoices.

### 2-3(D)(2)(xi) [Completion of As-Built Plans](#)

1. The Engineer of Record is responsible for checking out and correcting original drawings to As-Built conditions
2. As-Built drawings and data must be furnished to the Construction Engineer (private development), or CSD (Capital Improvement Projects) prior to the final project close-out. Criteria for As-Built drawings and Engineer Certification are covered in [Chapter 4 Construction Plan Standards](#).
3. Any approved change orders and/or design revisions shall be reflected on the As-Built drawings.
4. As-Built drawings must be certified by the State of N.M.-licensed Engineer or Surveyor. This certification shall state that project is in substantial compliance with the approved Grading and Drainage Plan.
5. The Engineer or Surveyor shall also declare the change in grade at the property line. Substantial changes in grade may require additional review by the Development Review Board and/or the original approving bodies.
6. As-Built drawings must also bear the Surveyor's Certificate, signed by a N.M.-licensed Surveyor.
7. Upon approval, the Construction Engineer or CSD signs As-Built drawings indicating concurrence with information shown.
  - a. *The as-built drawings are indexed into DMD Maps and Records Image Repository. Then, the process is initiated to update facility maps.*
  - b. *If water and/or sanitary sewer improvements were constructed, a copy of the As-Built drawings (see [Section 2-3\(D\)\(2\)\(xii\)](#) below) are sent to ABCWUA by the Construction Engineer.*

## POST-CONSTRUCTION PHASE

### 2-3(D)(2)(xii) [ACCEPTANCE BY THE ABCWUA](#)

1. ABCWUA shall receive a Certification of Substantial Compliance from the engineer of record and a ABCWUA closeout package for the water and/or sanitary sewer infrastructure.
2. If acceptable to the ABCWUA, the ABCWUA will issue a Letter of Conditional Project Acceptance and will accept and assume ownership and maintenance responsibilities for the facilities and is able to provide service

- to the subject development. It is to be noted that once the ABCWUA accepts the infrastructure, it will be booked as a ABCWUA asset.
3. The ABCWUA's acceptance of the facilities herein is expressly conditioned upon final acceptance of the project by the City of Albuquerque. The ABCWUA's conditional acceptance does not relieve the developer of any obligation or cost that may be required by the City Engineer as a final condition of project approval including, but not limited to, any additional obligation or cost related to sanitary sewer and/or water infrastructure. The contractor's one (1) year warranty period will begin from the date of the City Engineer's final acceptance of the project.
  4. Once the ABCWUA has accepted the infrastructure, the Developer may apply to the ABCWUA's New Services section for installation of water meters.
  5. The New Services Section will schedule an installation of the meters after payment of required fees.

### 2-3(D)(2)(xiii) Certificate of Completion and Acceptance

1. For Capital Improvement Projects – refer to **Section 10.7 Post Construction** of the *Project Manager Handbook* from the Department of Municipal Development.
2. For Private Development Projects, the following is required:
  - a. *The completed package shall be forwarded to the Construction Engineer. For requirements, refer to Work Order Close-out Review Checklist on the City of Albuquerque website.*
  - b. *After receiving the final quantities sheet and invoices from the Contractor, the Inspecting Agency prepares a Final Acceptance Recommendation. If an Infrastructure Improvements Agreement - Public and/or Private (Procedure B) was completed for the project, the following events also occur:*
    - i *If applicable, the documentation shall be accepted by the City Surveyor, and the Hydrology shall review and approve the Drainage Certification and Letter of Map Revision (LOMR).*
  - c. *The DRC shall determine, based upon actual construction cost, if additional engineering fees are required, and verifies with Construction Engineer that project can be accepted.*
  - d. *The Developer pays any required additional engineering fees.*
  - e. *When all fees are paid, the DRC Coordinator forwards the original work order package to the Construction Engineer for recommendation of final acceptance.*
  - f. *The DRC staff processes the Certification of Completion letter, the release of any applicable Agreements, any remaining financial guaranty or liens and forwards them to the City Engineer. The original financial guaranty is returned to the issuing financial institution or agency.*
    - i *If any of the improvements are to be included in a Public Improvement District (PID) or a Tax Increment Development District (TIDD), the City first issues a Letter of Work Order Completion which confirms that the improvements are complete and that the City is willing to accept the improvements after acceptance from the PID or TIDD board. Then the developer conveys the improvements to the PID or TIDD board, which reviews the proposed improvements. If the improvements are accepted by the board, they will notify the City of its acceptance of the improvements. The City then issues a Certification of Completion and Acceptance to the Developer.*

- g. After all signatures are obtained, the Releases are recorded with the County Clerk by the DRC staff with all originals filed with the City Clerk and copies of the documents sent to the developer and Consulting Engineer.*
- h. The Certificate of Completion is sent to all applicable parties.*

### **2-3(D)(2)(xiv) Warranty for Construction**

1. Prior to the expiration of the one year warranty period, a notification of the expiration of the warranty shall be forwarded to all applicable parties.
2. A City inspection of the construction shall take place before the expiration of the warranty period.
3. A punch list of any deficiencies shall be sent to the Contractor for correction prior to the warranty expiration date. If Contractor fails to correct deficiencies, the City reserves the right to call on the Performance and Warranty Bond, the Labor and Material Bond, or other legal recourse as necessary.



**WORK ORDERS**

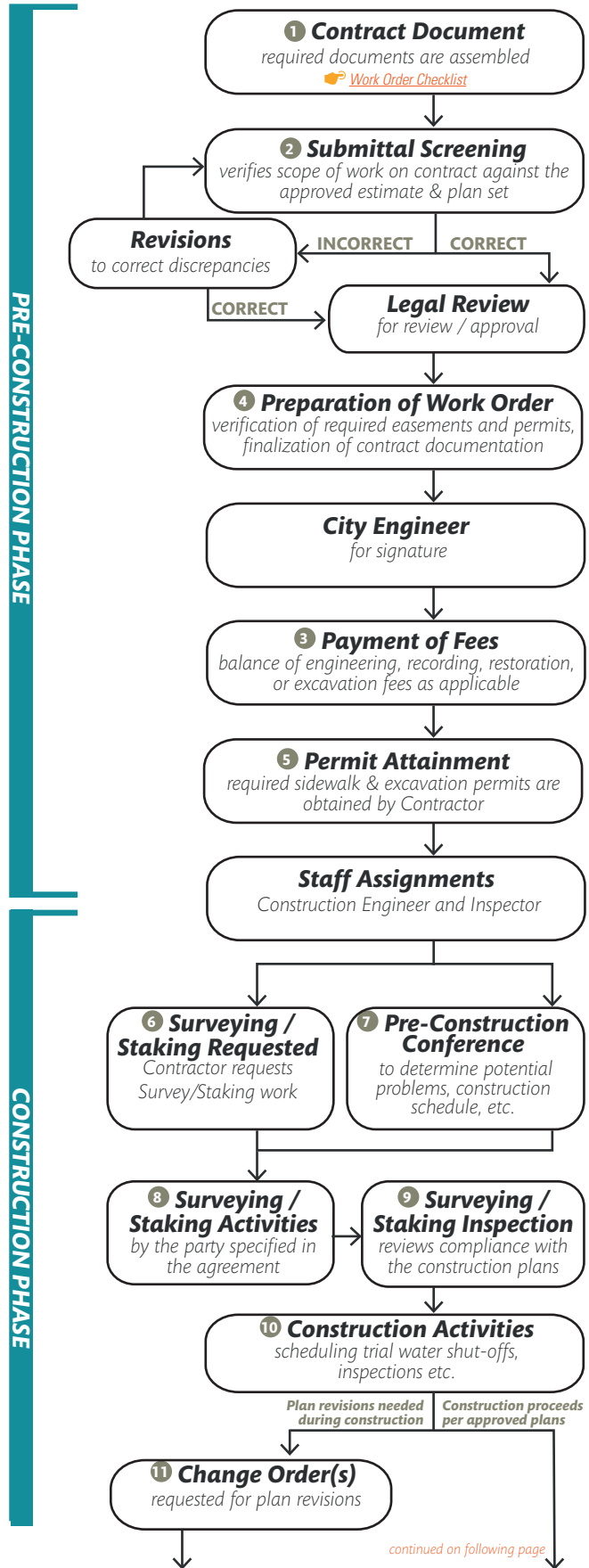
**PRE-CONSTRUCTION PHASE**

In this phase, the number and type of specific permits required for the project will be identified by the Building Official. Separate, appropriate permits must be obtained from the Building Official for each building, structure or building service.

- 1 Contract Document.** The Developer shall complete and submit all materials listed on the [Work Order Checklist](#) to the DRC Staff.
- 2 Submittal Screening.** The DRC Staff verifies that the scope of work on the contract is same as shown on DRC approved Estimate Sheet of Infrastructure Improvements and plan set.
- 3 Payment of Fees.** The Developer pays any outstanding pro-rata charges to ABCWUA and the required amount for engineering and recording, restoration, or excavation fees to the City, as applicable
- 4 Preparation of Work Order.** The DRC confirms that all required easements and permits have been obtained, signs the Estimate Sheet of Infrastructure Improvements indicating that the contract documentation is complete and the project is ready for issuance of Work Order, the packet is forwarded to the to City Engineer for review and approval. Then a Construction Engineer and Construction Inspector are assigned.
- 5 Permit Attainment.** The Contractor obtains all required permits noted on the [Work Order Issuance Checklist](#) and the [Estimate Sheet of Infrastructure Improvements of Infrastructure Improvements](#).
- 6 Surveying / Staking Requested.** The Contractor requests the Survey/Staking work to be done by the party specified in the agreement.
- 7 Pre-Construction Conference** is held to discuss the project schedule and any potential problems that may arise. Once the Pre-Construction Conference has occurred the construction phase may begin.

**CONSTRUCTION PHASE**

- 8 Surveying / Staking Activities.** After Surveying / Staking is complete, the Surveyor submits the construction staking notes/ cut sheets to the party responsible for inspection of the project, as identified in the agreement.
- 9 Surveying / Staking Inspection.** The Inspection Agency specified in the agreement reviews the construction staking notes/cut sheets for apparent compliance with the approved construction plans. If found acceptable, the Contractor is notified that construction operations may proceed.
- 10 Construction Activities.** Construction occurs per the approved plans. Field changes must be approved by the City Engineer, DRC, CSD, and/or the ABCWUA prior to their construction.
- 11 Change Orders.** Plan revisions made after Work Order issuance must be reviewed and approved by city staff, the Developer, the Contractor, and representatives of other government agencies as applicable.



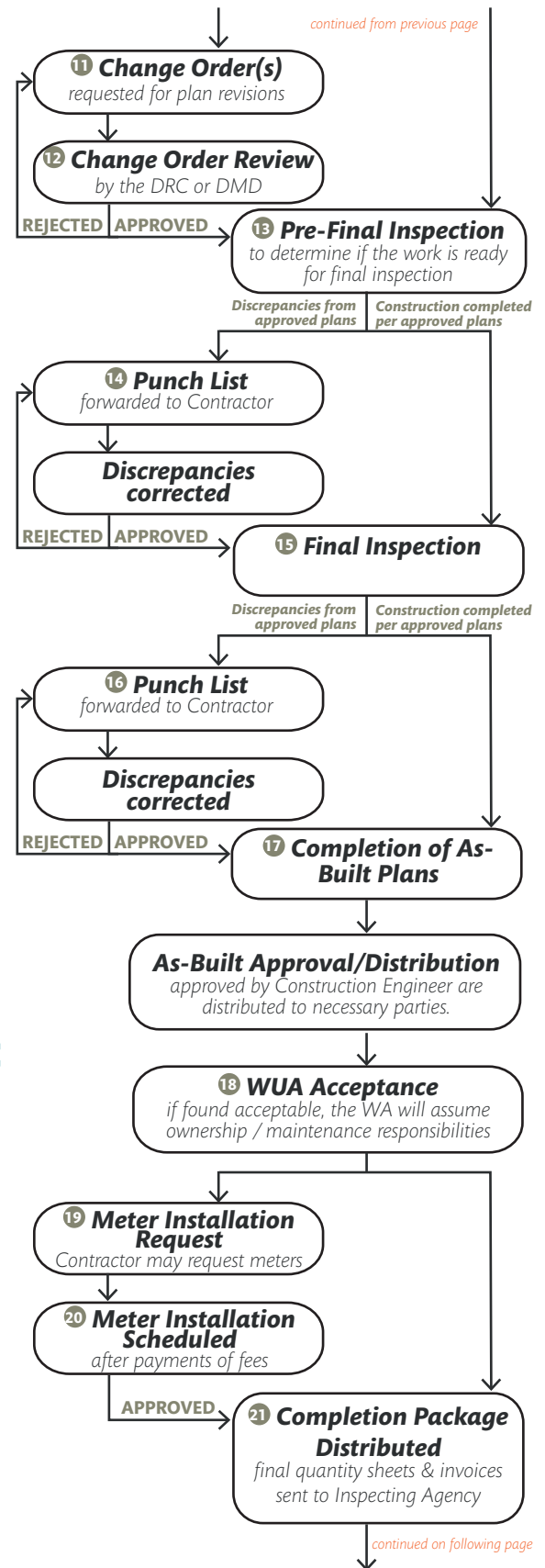
- 11 Change Order(s).** The Consulting Engineer submits the revised drawings indicating the proposed field changes to the DRC or DMD, as applicable.
- 12 Change Order(s) Review.** The City Engineer, DRC, CSD, and WA, or the DMD, will review change order requests and provides written approval to the applicant.
- 13 Pre-Final Inspection.** The Inspector, consulting engineer, and the Contractor conduct a pre-final inspection to determine if the work is ready for final inspection. If project is ready for final inspection all involved parties are notified.
- 14 Punch List.** If project is not ready for final inspection, the Contractor will receive a list of discrepancies that must be completed prior to scheduling final inspection.
- 15 Final Inspection.** A final inspection occurs with the Contractor, Consulting Engineer, the Developer, all city staff concerned with the project, and other government agencies, as applicable to ensure the project was constructed as approved.
- 16 Punch List.** At final inspection, a list of discrepancies (punch list) is prepared by the Consulting Engineer or CSD which is given to the Contractor for correction. The Contractor must correct all discrepancies and notify the Inspector(s) that the work is ready for verification.
- 17 Completion of As-Built Plans.** As-Built drawings and data must be furnished to the Construction Engineer (private development), or CSD (Capital Improvement Projects) prior to the final project close-out. Criteria for As-Built drawings and Engineer Certification are covered in [Chapter 4, Construction Plan Standards](#).

**POST-CONSTRUCTION PHASE**

- 18 ABCWUA Acceptance.** The ABCWUA receives a Certification of Substantial Compliance from the engineer of record and a ABCWUA closeout package for the water and/or sanitary sewer infrastructure. If acceptable to the ABCWUA, the ABCWUA will issue a Letter of Conditional Project Acceptance and will accept and assume ownership and maintenance responsibilities for the facilities.
- 19 Meter Installation Request.** Once the ABCWUA has accepted the infrastructure, the Developer may apply to the ABCWUA's New Services section for installation of water meters.
- 20 Meter Installation.** The New Services Section will schedule an installation of the meters after payment of required fees.
- 21 Completion Package Distributed.** For Capital Improvement Projects – refer to [Section 10.7 Post Construction of the Project Manager Handbook](#). For private development, the completed package shall be forwarded to the Construction Engineer and the Inspection Agency.
- 22 Final Acceptance Recommendation Prepared.** After receiving the final quantities sheet and invoices from the

PRE-DESIGN PHASE

POST-CONSTRUCTION PHASE



Contractor, the Inspecting Agency prepares a Final Acceptance Recommendation.

**23 Payment of Fees.** The DRC shall determine, based upon actual construction cost, if additional engineering fees are required. The Developer pays any required additional engineering fees.

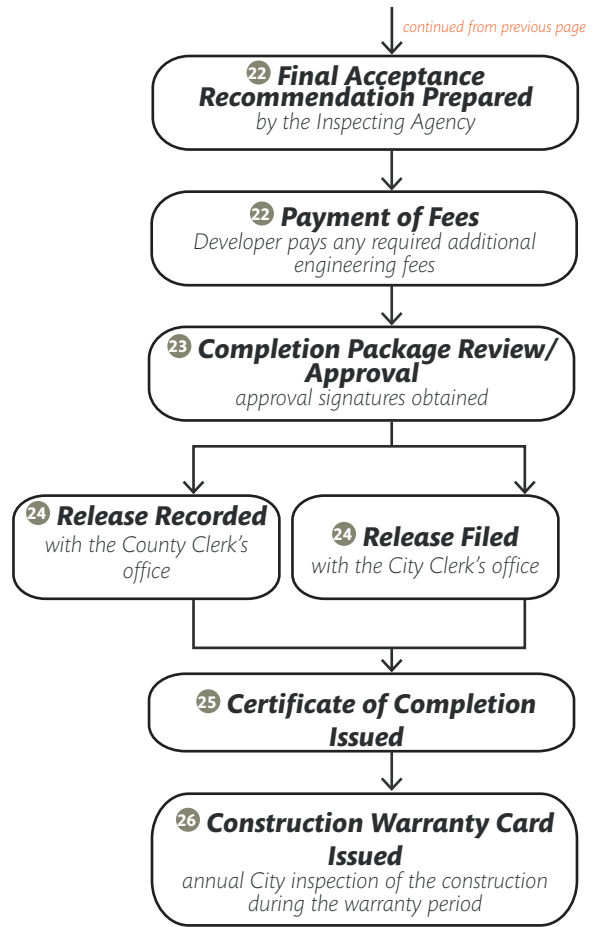
**23 Completion Package Review/Approval.** When all fees are paid, the DRC Coordinator forwards the original work order package to the Construction Engineer for recommendation of final acceptance. The DRC Staff processes the Certification of Completion letter, the release of any applicable Agreements, any remaining financial guaranty or liens and forwards them to the City Engineer. The original financial guaranty is returned to the issuing financial institution or agency. The applicable signatures needed to close out the package are obtained.

**24 Release Recorded/Filed.** After all signatures are obtained, the Releases are recorded with the County Clerk by the DRC Staff with all originals filed with the City Clerk.

**25 Certificate of Completion Issued.** Copies of the Certificate of Completion is sent to all applicable parties.

**26 Construction Warranty Card Issued.** Prior to the expiration of the one year warranty period, a notification of the expiration of the warranty shall be forwarded to all applicable parties. A City inspection of the construction takes place before the expiration of the warranty period and a punch list of any deficiencies shall be sent to the Contractor for correction prior to the warranty expiration date.

**POST-CONSTRUCTION PHASE**



## ARTICLE 2-4 PRIVATE INFRASTRUCTURE IMPROVEMENTS

Article 2-4 outlines the procedures for design development, approval and construction of Private Infrastructure Improvements. Since many of the procedures are the same as those presented in [Article 2-3](#) these procedures are referenced herein, for brevity rather than being duplicated.

### Part. 2-4(A) Applicability

This section applies to private infrastructure improvements located in private ways or in easements and are maintained by private entities, such as Homeowner's Associations. (A common example of such private infrastructure improvements may be a series of private roads within a subdivision.) If public infrastructure improvements are to be located in a private way, an easement must be provided. Public infrastructure improvements in private ways must be designed and constructed according to procedures described in [Article 2-3](#).

Approval to design and construct private infrastructure improvements depends on the determination of the Development Review Board (DRB) (See the [IDO](#)) that private ways can adequately serve all identified transportation, utility and storm drainage requirements. The City requires that the City Traffic Engineer approve the creation of private ways before final approval by the Planning Director. The Traffic Engineer's approval is based on the reasonable likelihood that the street will always function as a local street. The DRB may require easements in private ways for public utilities before granting approval. Prior to plat approval, the DRB will also require the developer to either construct private infrastructure or post a financial guarantee to ensure that all required infrastructure is constructed.

The City of Albuquerque as a rule will not accept private infrastructure improvements for ownership or maintenance. In the event that the owners/maintainers of private facilities decide at a later date that they would like to dedicate those facilities to the City for ownership and maintenance, the terms and conditions of that dedication and the affected facilities will be subject to City staff review and approval. Due to the unusual nature and potentially varied circumstances, a specific procedure does not exist. Items to be considered may include: dedication of right-of-way, compliance with appropriate City standards, a one (1) year warranty from date of acceptance (required by City), reproducible As-Built drawings certified by a N.M. Registered Professional Engineer. Contact the DRC Chair at the Plaza Del Sol Building for further advice.

### GOVERNING REGULATIONS

Governing regulations are those listed on the [Infrastructure Improvements Governing Regulations Summary](#), plus the most recent edition of the [Uniform Plumbing Code](#).

## **Part. 2-4(B) PRIVATE FACILITIES IN PUBLIC RIGHT-OF-WAY**

Privately owned and maintained facilities proposed to be built within public rights-of-way or easements are not covered by this section. An overview of potential occurrences and appropriate procedures defined elsewhere in the DPM follows.

4. PRIVATE DRAINAGE FACILITIES IN PUBLIC RIGHT-OF-WAY (See DPM, [Chapter 6](#), Drainage)  
This process applies to privately owned and maintained drainage outfall facilities.
5. REAL PROPERTY ENCROACHMENT AGREEMENT AND COVENANTS UPON REAL ESTATE (See [Part. 2-7\(E\)](#))  
This process is designed primarily for installation of private facilities or structures such as walls, fences, or car ports on public right-of-way or easements for public infrastructure. Note that similar requirements exist with private utility companies for construction on their easements or right-of-way.
6. AGREEMENT AND COVENANT (Reference not available. Contact City Engineer's Office)  
Such improvements are to be constructed and maintained by the licensee. This license is binding upon the land of the licensee for which the improvements are constructed. The Agreement and Covenant may be amended to suit other improvements or conditions as approved by the City Engineer.

## **Part. 2-4(C) Procedural differences**

### **Section. 2-4(C)(1) PRIVATE INFRASTRUCTURE DESIGN DEVELOPMENT**

1. The developer must engage a New Mexico Registered Professional Engineer to design private infrastructure improvements to ensure that minimum requirements will be met and subsequently constructed. Minimum standards for paving, water, sanitary sewer and storm drainage as described in the Development Process Manual must be adhered to by the consulting engineer. Among the items which must meet requirements are:
  - a. *Street width and turnaround adequacy to accommodate emergency and refuse vehicles*
  - b. *Adequate number and type of water valves, sewer manholes, and water loop lines*
  - c. *Developer's proposal for management of external storm flows coming onto the property and internal flows discharged from the property*
  - d. *Adequate size of water lines to serve an adequate number of fire hydrants for the subdivision or development*
2. Procedures and plan formats for design of private infrastructure improvements are the same as defined in [Article 2-3](#), for public infrastructure improvements, except as follows:

- a. *The Application for Design and Construction of Infrastructure Improvements must be accompanied by a Private Infrastructure Supplement to Application.*
- b. *[Letter of Instruction](#) for Procedure "A" is replaced by Letter of Instruction for Private Infrastructure.*

## **Section. 2-4(C)(2) CONSTRUCTION OF PRIVATE INFRASTRUCTURE**

All private infrastructure improvements must be inspected under the direction of a New Mexico Registered Professional Engineer and certified complete in accordance with approved plans and specifications. Such certification shall also include verification of inspection and approval by Planning Department/Code Administration Division for compliance with applicable building codes (see Uniform Administrative Code for details).

### **2-4(C)(2)(i) [CONSULTING ENGINEER INSPECTION](#)**

1. Construction permits for the work on private property must be obtained from Planning Department.
2. The consulting engineer must verify that the contractor requests and obtains necessary inspections and approvals during the course of the construction.
3. Upon satisfactory completion of the private infrastructure improvements the consulting engineer shall submit to the City Engineer the following:
  - a. *A statement that he/she is currently a Registered Professional Engineer in the State of New Mexico.*
  - b. *Certification that the described improvements were inspected under his/her direction and constructed in accordance with the approved plans and specs.*
  - c. *Final tabulation of quantities with explanation of overruns and underruns (See [Article 2-1](#)).*
  - d. *Material test data.*
  - e. *Reproducible As-Built drawings (may amend approved originals retained by Engineering Design Section).*
  - f. *Certification that the finished grade is in substantial compliance with the approved grading and drainage plans.*
4. Upon review and approval of constructed improvements and certification by consulting engineer, the City Engineer will issue a Certificate of Completion to the developer. The format is similar to Certificate of Completion and Acceptance ([Section 2-4\(B\)\(13\)](#)).
5. Ownership and Maintenance of private infrastructure remains the responsibility of the developer, Homeowners' Association or individual lot owner(s) as indicated on the plat.



## ARTICLE 2-5 COMMERCIAL, PUBLIC, MULTI-FAMILY BUILDING PERMITS

The material in this section applies to the construction process regulated by local ordinances and policies for new public, commercial and multi-family buildings or alterations to those structures.

Building permits relating to single-family, homeowner construction projects can be found through the [Homeowners How-to-guide](#) on the Building Safety Division's website.

### Part. 2-5(A) Applicability

Article 2-5, applies to the proper permitting (e.g., Building Permits) for the construction process of new public, commercial and multi-family buildings. A building permit authorizes a property owner or their designated representative to retain a licensed contractor for construction or alteration of a specific building. The permit implies that plans have been reviewed and approved to ensure that the necessary requirements for the protection of public safety and the proper use of land have been met to the best knowledge of the reviewers. Specific permits and additional steps are required depending on the nature and complexity of the project.

Specific permits and additional steps are required depending on the nature and complexity of the project. The property owner or designated representative must engage the services of a registered architect and/or registered professional engineer licensed to practice in the State of New Mexico to prepare and seal all plans and specifications. The information included in this section is directed to the design professional. The term "applicant" as used in this chapter refers to the owner, the design professional and/or licensed contractor.

### Part. 2-5(B) Governing Regulations

Plans and specifications must be prepared according to the ordinances and policies listed in the [Public, Commercial and Multi-Family Building Permit Governing Regulations Summary](#).

### Part. 2-5(C) Procedure

#### Section. 2-5(C)(1) Preliminary Plan Check Services

1. Preliminary plan check services are available to the design professional for the purpose of reviewing the requirements of the Albuquerque codes and ordinances. Specifically, the consultation will resolve any questions concerning the interpretation and coordination of basic design criteria prior to final plan submittal for plan check.
2. Preliminary plan checks are not mandatory. Applicants who chose to schedule additional plan check services will be charged a minimal service fee.

#### PRE-DESIGN PHASE

*During this phase the architect/engineer must become knowledgeable of the state and local regulations, design criteria, and standards relevant to the specific project. In addition, water and sanitary sewer service availability should be verified and a pre-design meeting should be held with the Design Hydrology Section. Separate, appropriate permits must be obtained from the Building Official for each building, structure or building service. In this phase, the number*



and type of specific permits required for the project will be identified by the Building Official.

All projects require a general building permit and separate electrical, plumbing and mechanical permits. Other permits may include but are not limited to:

- Alteration (Remodel)
- Barricade
- Curb Cut
- Demolition (Removal)
- Flood Hazard Certificate
- Foundation Only
- Repair
- Sign
- Swimming Pool
- Topsoil Disturbance
- Walls, Fences, Retaining Walls

3. The applicant must be prepared with basic code data and not be dependent on the Building Official for this data.

### Section. 2-5(C)(2) Plan Preparation

1. Once the anticipated use and size of any commercial or multi-family building is determined, the applicant, prior to final drawing preparation, should contact one or more of the following agencies for resolution of unclear matters:
  - a. **Zoning Enforcement** to verify that the intended use is allowable in that zone. Discuss the particular applicable requirements for:
    - i Height (including solar access information),
    - ii Setback,
    - iii Landscaping,
    - iv Parking - number of spaces,
    - v Park dedication and development fees,
    - vi Stationary railroad cars,
    - vii Airport zoning (height regulation),
    - viii Conformance with applicable site development and/or landscaping plans or any conditional use/variance approvals,
    - ix Special exceptions,
    - x Overlay zones,
    - xi Plot Plan.
  - b. **Refuse** to identify the necessary requirements for analysis of refuse needs.
    - i Determine necessary number, type, and location of refuse enclosures.
    - ii Determine access needs for collection.
  - c. **Water Resources**<sup>1</sup> to verify water and sanitary sewer services availability.
    - i Obtain availability statement prior to issuance of building permit.
    - ii Determine industrial pre-treatment requirement.
  - d. **Transportation** to determine applicable requirements for the preparation of a traffic site plan (see [Chapter 7 Transportation Design](#)):
    - i The location and number of curb cuts,
    - ii The location of sidewalks,
    - iii Bus stops, turn bays and median cuts,
    - iv Parking layout and circulation,
    - v ADA and PROWAG requirements.
  - e. **Hydrology** to obtain the necessary requirements for the preparation of a Drainage Report and/or Drainage Plan, and grading plan (see [Chapters 2 and 4](#)).
    - i Ascertain location relevant to flood hazard areas.
    - ii The hydrology review process should begin independent of the building permit application and should generally start prior to submittal of building construction plans.
  - f. **Fire Marshal** to determine Fire Code compliance.
    - i Identify access needs for equipment.
    - ii Determine required fire flow and number of hydrants, and required coordination for pressure flow with Public Works, Water Resources.
  - g. **Environmental Health** to determine applicable requirements for:

<sup>1</sup> The City will accept letters of credit, escrow letters and loan reserve letters which meet all other City requirements only if the issuing financial institutions are insured by FSLIC or FDIC. If a developer proposes to submit a financial guarantee letter issued by a non-federally insured financial institution, the proposal must be submitted to, and be approved by the City's Legal Department in advance of the institution issuing the financial guarantee letter.

- i Food sanitation,
- ii Air quality registration and permitting of all stationary sources of air pollution,
- iii Surface disturbance, building renovation and demolition, and
- iv Water testing of pools and other recreational water.

**APPLICATION FOR PLAN CHECK PHASE**

**Section. 2-5(C)(3) Application for Plan Check**

1. Permit application submittals are submitted to the Building Safety Division via the permit counter or electronically via the POSSE system. Required application materials include:
  - a. A completed application form including the information indicated in the UAC Section 110.
  - b. The Plan Check fee which must be paid at time of application.

**Section. 2-5(C)(4) Plan Check**

1. Upon receiving the application, the Building Safety processes the plans:
  - a. A plan location log is established to track the plan check process. Applicant may call for information.
  - b. The plans are forwarded to specialists in the following review agencies<sup>2</sup>:
    - i Zoning Enforcement/Refuse
    - ii Hydrology
    - iii Traffic Engineering
    - iv Environmental Health
    - v Fire Marshall
    - vi Building
    - vii Plumbing and Electrical
  - c. When the plan check process is completed, Building and Safety notifies the applicant's architect or engineer by phone.
  - d. The Applicant is then free to pick up plans at the permit desk.
    - i If plans are correct as submitted, the applicant may apply for a building permit following requirements as outlined in the Building Permit Issuance Phase.
    - ii If plans are incorrect, the applicant must coordinate correction of rejections with the responsible reviewing agency. Satisfactory corrections will be certified for approval by the responsible reviewing agency.
    - iii Any rejection, conflicts or questions of interpretation which cannot be resolved between the applicant and the reviewing agency are first brought to the attention of the Building Official. If the conflicts still cannot be resolved, they may be referred to the appropriate appeal body.

**PERMIT APPROVAL PHASE**

A permit authorizes a property owner or their designated representative to retain a licensed contractor for construction or alteration of a specific building. The permit implies that plans have been reviewed and approved to ensure that the necessary requirements for the protection of public safety and the proper use of land have been met to the best knowledge of the reviewers.

**Section. 2-5(C)(5) Building Permit Issuance**

1. Approved plans are processed by the permit clerk at the building permit counter, Building Safety Division.
2. Upon receipt of the approved plans, Permit clerk begins to issue the building permit:
  - a. The building permit printed.
  - b. The contractor's state license is verified to ensure it is current/valid.
  - c. The Inspection Notice Card which is used to record dates specific inspections are completed is issued.

<sup>2</sup> See the appropriate agency for checklists.

Staff of Building Safety will inform applicant of the procedures for applying for the various required specific permits. The procedures described in this section apply only to the general building permit for new public, commercial and multi-family buildings.

- d. One set of plans is returned to the applicant to be placed at the project site; the second set of plans is filed Building Safety.
3. When plans are received, the contractor:
  - a. Pays the building permit fee.
  - b. Pays the impact fees as required.
  - c. Shows verification of the business registration permit.
  - d. Shows State of New Mexico Gross Receipts Tax No., if applicable.
4. Once building permits are received, construction can begin.

## INSPECTION PHASE

During the construction process, after permits are issued, inspections are required to ensure compliance with approved plans and ordinances. Applicants are notified of required inspections at issuance of the specific permit. Design Hydrology inspections are normally made only upon completion of site construction. Intermediate inspections may be made as required for underground facilities. See UAC for construction inspection requirements.

### Section. 2-5(C)(6) Construction Inspections

1. The following types of inspections are generally always required:
  - a. Building
  - b. Plumbing and Mechanical
  - c. Electrical
2. Other types of inspections which may be required are as follows:
  - a. Zoning
  - b. Transportation
  - c. Environmental Health
  - d. Hydrology
  - e. Fire Prevention
  - f. Specific types of inspections are detailed in the Uniform Administrative Code, Section 305.
3. The contractor is responsible for scheduling interim inspections. For inspections to be completed, the following items must be located at the project site:
  - a. The Inspection Notice Card.
  - b. The approved set of plans.
4. Depending on the results of the inspection, the inspector posts either:
  - a. An approval tag indicating work passes inspection,
  - b. A correction notice indicating code deficiencies which must be corrected before violations are concealed, or
  - c. A stop work notice indicating that work in that particular category must be stopped and corrections made and approved before work can continue.
5. The outcome of the inspections is recorded in the permit file at Building Safety.
6. If corrections are necessary, the contractor is responsible for making the corrections and scheduling a re-inspection.

## CERTIFICATE OF OCCUPANCY PHASE

All new public, commercial and multi-family structures must be issued a Certificate of Occupancy before they can be used or occupied. It is unlawful, and more importantly unsafe, to occupy a public, commercial or multi-family building without the Certificate of Occupancy. All inspections must be passed before issuance.

### Section. 2-5(C)(7) Certificate of Occupancy

1. After all inspections are passed showing compliance with approved plans, the contractor requests a Certificate of Occupancy from Building Safety. To obtain the certificate, the contractor must bring the signed permit card to the certification of occupancy issuance desk.
2. The permit clerk verifies that all inspections have been passed against the records in the permit file.
3. Verification of the required approval allows the Certificate of Occupancy to be issued.
4. The certificate must be posted in a conspicuous place on the building premises.

**COMMERCIAL, PUBLIC, MULTI-FAMILY BUILDING PERMITS**

**PRE-DESIGN PHASE**

In this phase, the number and type of specific permits required for the project will be identified by the Building Official. Separate, appropriate permits must be obtained from the Building Official for each building, structure or building service.

**1 Preliminary Plan Check Services.** are available to the design professional for the purpose of reviewing the requirements of the Albuquerque codes and ordinances.

**APPLICATION FOR PLAN CHECK PHASE**

During this phase, final plans are reviewed by appropriate agencies for compliance with regulations governing the construction process.

**2 Application for Plan Check.** Required application form, plans, and specifications are submitted to Building Safety and the Plan Check fee is paid.

**3 Plan Check Review.** Final plans are reviewed by appropriate agencies for compliance with regulations governing the construction process. Plans must conform to adopted construction codes as well as zoning regulations, energy conservation measures, transportation considerations, drainage policy and others.

**PERMIT APPROVAL**

Building Safety Staff will inform applicant of the procedures for applying for the various required specific permits.

**4 Application for Building Permit.** If plans are correct as submitted, the applicant may apply for a building permit by submitting required materials to the clerk at the building permit desk of the Code Administration Division.

**INSPECTION PHASE**

During the construction process, after permits are issued, inspections are required to ensure compliance with approved plans and ordinances.

**5 Interim Inspections.** The contractor is responsible for calling for interim inspections. Generally, the following types of inspections are always required Building, Plumbing and Electrical, but other types of inspections may be required for Zoning, Environmental Health, Hydrology, Fire Prevention.

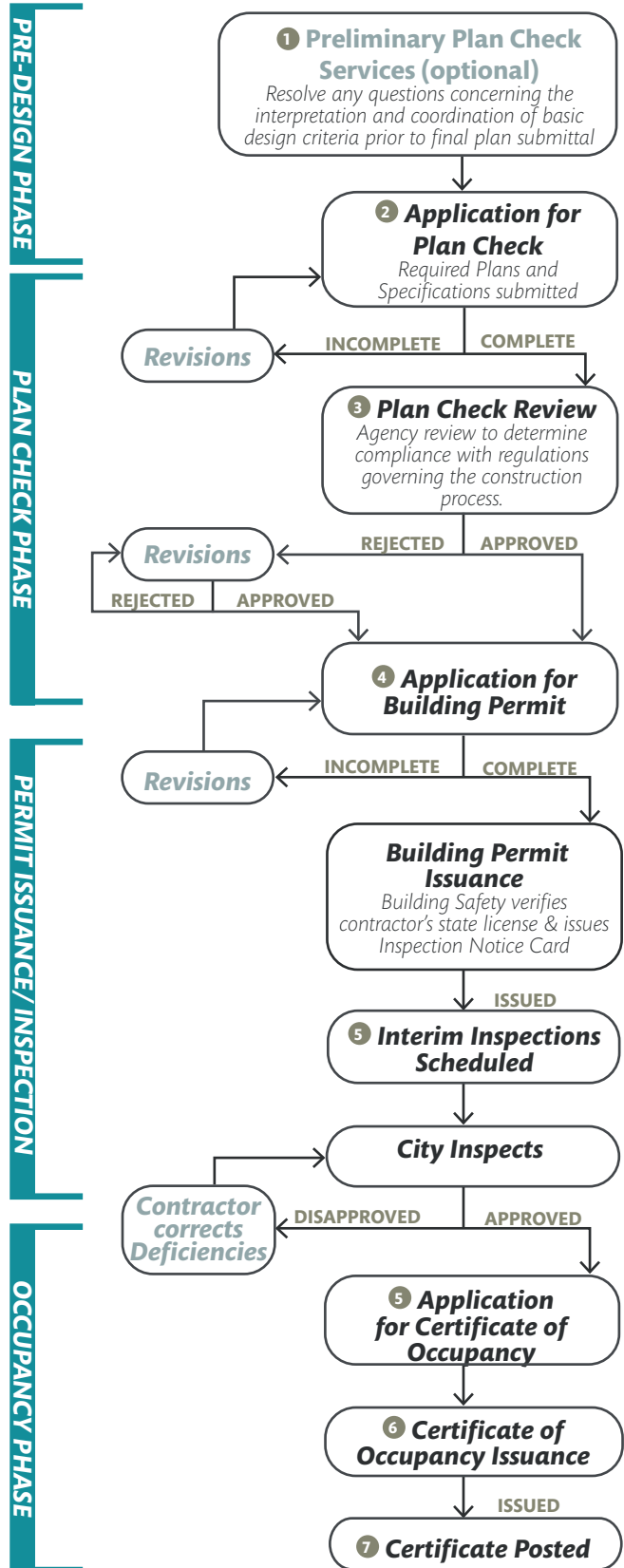
**CERTIFICATE OF OCCUPANCY PHASE**

All new public, commercial and multi-family structures must be issued a Certificate of Occupancy before they can be occupied.

**5 Application for Certificate of Occupancy.** After all inspections are passed showing compliance with approved plans, the contractor requests a Certificate of Occupancy from Building Safety.

**6** If all inspections have passed, a Certificate of Occupancy is issued.

**7** The certificate shall be posted in a conspicuous place on the building premises.



## ARTICLE 2-6 RELATED BUILDING PERMITS

Article 2-6 covers any related building permits which are required for the construction on private property. These permits are distinct from and often required in addition to a building permit. For example, walls, fences and retaining walls which are included on the construction plans for a larger project require a separate permit. [TABLE 2.6.2](#) summarizes related permits that may be required in addition to a building permit. Generally, the application information, plans/specifications, and procedural requirements for related building permits are similar to those described in [Article 2-5](#), with some exceptions which are indicated in the procedural deviation column of [TABLE 2.6.2](#). The sections following the table explain these procedural deviations in further detail.

**TABLE 2.6.2 Summary of Related Building Permits**

Permit Type	Applicability	Procedural Deviations
<b>Demolition</b>	Demolition work may require a permit from Building Safety. Under Albuquerque-Bernalillo County Air Quality Control Board 20.11.20 NMAC, demolition of structures 75,000 cubic feet or larger requires an additional permit from the Environmental Health Department, Air Quality Program to insure that adequate measures are taken to control fugitive dust.  Structures 10,000 sq. ft or larger built or renovated prior to January 1st, 1980 require an approved Erosion and Sediment Control Plan and an approved Stormwater Control Permit for Erosion and Sediment Control from Stormwater Quality.	<a href="#">PART. 2-6(A)</a>
<b>Elevator</b>	Installation of elevators requires a separate permit. Detailed elevator plans must be submitted for plan review prior to permit issuance.	
<b>Fire Repair</b>	All restoration work following a fire requires a permit. Applicant must submit a statement or schedule of all remedial work including structural items. For extensive structural repairs, submit drawings certified by a New Mexico registered architect or engineer, clearly defining proposed remedial work.	
<b>Floodplain Development Permit</b>	All earthmoving, grading, paving, building additions, and new building construction in a Special Flood Hazard Area, SFHA requires a Floodplain Development Permit.	<a href="#">PART. 2-6(B)</a>
<b>Flood Hazard Certification</b>	Compliance with the requirements of the Flood Hazard Ordinance is required of every applicant for subdivision, site development plan and/or building permit approval. Compliance is achieved by either demonstrating that the proposed project does not lie within a designated flood hazard area or by demonstrating adequate flood-proofing as required by the ordinance or by removing the site from a flood hazard area through the FEMA map revisions process.	
<b>Foundation Only</b>	A Foundation Only Permit allows construction of footings, foundation walls and any other construction up to and including a first floor slab upon approval of required plans and application material. A building permit is required before progressing with work beyond the foundation stage. The issuance of a foundation permit does not preclude the possibility that changes might be necessary to meet building code requirements or requirements of any other city ordinance or laws relating to construction.	<a href="#">PART. 2-6(C)</a>

TABLE 2.6.2 Summary of Related Building Permits

Permit Type	Applicability	Procedural Deviations
<b>Grading Permit &amp; Paving Permit</b>	<p>A Grading Permit is required for all grading of 1.0 acre or more or 500 cubic yards and any grading to be done within or adjacent to a watercourse (defined as a major facility) during the months of July, August or September. Paving an area larger than 2000 square feet requires a Paving Permit. Repaving of existing paved areas in which no grading is planned is excluded.</p> <p><i>Note: Grading and Paving Permits are not required when the proposed grading and paving are a part of a Building Permit.</i></p>	<a href="#">PART. 2-6(D)</a>
<b>Notification of Demolition or Renovation</b>	Demolition work on any commercial building or residential building containing five (5) or more dwelling units requires an Asbestos Demolition/Renovation Notification to be filed with the Air Quality staff a minimum of ten (10) working days prior to the start of the demolition. This notification is also required for residential buildings that are demolished for the purposes of building non-residential structures. This notification is separate from the "Surface Disturbance/Demolition" form and is required regardless of whether or not asbestos is present.	
<b>Plumbing &amp; Electrical</b>	All electrical, plumbing and mechanical work requires a permit.	<a href="#">PART. 2-6(D)</a>
<b>Relocation of Existing Buildings</b>	Relocation of existing buildings requires the determination of necessary modifications to meet technical codes, a foundation permit, remodeling permit, and electrical, plumbing and mechanical permits, as appropriate. In addition, the Traffic Code (Subsection 4.67) requires a permit for oversize, overweight and/or overlength truckloads to be issued prior to actual moving of the building.	<a href="#">PART. 2-6(F)</a>
<b>Sign</b>	Most new signs erected in the city require a zoning permit and a building permit. Current zoning regulations detail standards applicable to signs in all zones and defines the types of signs which do and do not require a zoning permit.	<a href="#">PART. 2-6(G)</a>
<b>Swimming Pool</b>	<p>All below ground public or private swimming pools require a permit and separate electrical, plumbing, and mechanical permits. Swimming pool plans will be reviewed by NM Gas Company/PNM and Qwest Corporation to ensure that utility lines are not interfered with and by the Environmental Health Department to ensure that the plans for public swimming pools meet the requirements of the Swimming Pool Ordinance.</p> <p>In addition the Swimming Pool Ordinance requires a permit for the operation of public swimming pools. The procedure for obtaining this permit is found in <a href="#">Part. 2-7(L)</a></p>	
<b>Wall, Fence, and Retaining Walls</b>	A permit is required for retaining walls 24" high or higher and for walls and fences higher than 6 feet. Walls or fences, or their footings proposed to be located in the public right-of-way, require the execution of an Revocable Permit or Encroachment Agreement (See Section 2-7.5).	<a href="#">PART. 2-6(H)</a>



[Article 2-7](#), describes any additional permits for construction within the public right-of-way which may be required in addition to the permits outlined above. These permits are established by legislation other than the Uniform Administrative and Technical Codes and administered by agencies other than Development and Building Services. The permits/approvals included in Section Article 2-7 are outlined in [TABLE 2.6.3](#), but [Article 2-7](#) should be consulted for further details on required procedures for other construction permits.

<b>TABLE 2.6.3 Summary Other Construction Permits</b>		
<b>Permit Type</b>	<b>Applicability</b>	<b>Procedures</b>
<b>Air Contaminant Sources Registration</b>	Air Contaminant Source Registration is required for the operation of a commercial or industrial stationary source with actual emissions of more than two thousand pounds of any air contaminant per year or any amount of a hazardous air pollutant.	<a href="#">PART. 2-7(A)</a>
<b>Authority to Construct Permit</b>	An Authority to Construct Permit is required for the construction or modification of any commercial or industrial structure which, if it were uncontrolled, would result in an emission of air contaminants greater than ten pounds per hour or twenty-five tons per year (except five tons per year for lead; ten tons per year for hazardous air pollutants).	<a href="#">PART. 2-7(B)</a>
<b>Barricade Permit</b>	A Barricade Permit is required prior to excavation of any accepted City right-of-way including the setback area or when construction or demolition work interferes with vehicular or pedestrian traffic. Currently, Barricade Permits are not required for work in previously unimproved City streets or rights-of-way; however, the construction zone is required to be barricaded in accordance with the requirements of the Traffic Code.	<a href="#">PART. 2-7(C)</a>
<b>Blasting Permit</b>	A Blasting Permit is required for all blasting work within the City Limits issued by the Albuquerque Police Department. Applicants for a Blasting Permit must present a Certificate of Insurance for \$500,000/1,000,000/500,000 combined incident liability, structure damage, bodily injury and property damage.	<a href="#">PART. 2-7(D)</a>
<b>Encroachment Agreement</b>	The execution of an Encroachment Agreement between the City and the property owner is required for proposed construction of private walls, footings, fences, or other privately owned infrastructure within a public easement on a conditioned basis.	<a href="#">PART. 2-7(E)</a>
<b>Excavation Permit</b>	Any excavation activity within the public right-of-way requires an Excavation Permit.	<a href="#">PART. 2-7(F)</a>
<b>Integrated Development Approvals</b>	References all development activities that are authorized by the Integrated Development Ordinance (IDO).	<a href="#">PART. 2-7(G)</a>
<b>Median Cut &amp; Left-Turn Lane Approval</b>	Proposed median cuts and left turn lanes require City approval to insure that spacing requirements, the type of development, internal circulation and existing or projected traffic operating conditions are considered. In addition, the location and design of median cuts in streets which are a part of the State Highway System require approval of the New Mexico Department of Transportation.	<a href="#">PART. 2-7(H)</a>
<b>Oversize, Overweight and/or Overlength Truckload Permit</b>	The movement or operation of oversize, overweight and/or over length vehicles on City streets requires an oversize, overweight and/or over length truckloads permit issued by the City's Department of Municipal Development - Construction Coordination. The New Mexico Vehicle Laws, Section 64- 23-13 through 64-23-20, define the dimensions and weight of vehicles which require this permit.	<a href="#">PART. 2-7(I)</a>
<b>Permit SO-19</b>	Construction of a private storm drain facility in a public right of way may be accomplished with an SO-19 Permit when a Work Order is not otherwise required.	<a href="#">PART. 2-7(J)</a>



<b>TABLE 2.6.3 Summary Other Construction Permits</b>		
<b>Permit Type</b>	<b>Applicability</b>	<b>Procedures</b>
<b>Public Use of Fire Hydrants</b>	Connections to fire hydrants at any location are prohibited without written permit from the Albuquerque Bernalillo County Water Utility Authority (ACWUA) except for City of Albuquerque street sweepers, street rollers and Fire Department vehicles. All other private and governmental users - federal, state, county, city and military - must have a permit. A Designated Permit allows the permit holder to use any of approximately twenty-nine (29) designated hydrants located within the City and County limits. A Special Permit is required for private use of other fire hydrants not noted above.	<a href="#"><i>PART. 2-7(K)</i></a>
<b>Public Swimming Pool Operating Permit</b>	The operation and maintenance of public swimming pools requires a Public Swimming Pool Operating Permit. A pre-opening inspection and permission to operate is required on all seasonally operated facilities before the expected opening date.	<a href="#"><i>PART. 2-7(L)</i></a>
<b>Revocable Permit</b>	The execution of a Revocable Permit between the City and the property owner is required for proposed construction of private walls, footings, fences, signage, or any other privately owned infrastructure within public right-of-way on a conditioned revocable basis.	<a href="#"><i>PART. 2-7(M)</i></a>
<b>Sewer Tapping Permit</b>	A Sewer Tapping Permit is required to tap into existing sewer lines.	<a href="#"><i>PART. 2-7(N)</i></a>
<b>Sidewalk, Driveway &amp; Curb &amp; Gutter Permit</b>	Any work within the City's right-of-way requires a permit and stipulates whom can conduct the work.	<a href="#"><i>PART. 2-7(O)</i></a>
<b>Stormwater Control Permit for Erosion and Sediment Control</b>	Projects that disturb one acre or greater, are smaller than one acre, but part of a larger common plan of development or may have other criteria (e.g. steep slopes, contaminated soils, etc.) are required to obtain this permit.	<a href="#"><i>PART. 2-7(Q)</i></a>
<b>Solar Rights Permit</b>	A solar right permit is required to define and regulate the spatial and temporal limits of a property's solar right.	<a href="#"><i>PART. 2-7(P)</i></a>
<b>Surface Disturbance Permit</b>	A Fugitive Dust Construction or Programmatic Permit, as applicable, is required for all activities that will have a surface disturbance of equal to or greater than 3/4 of one acre.	<a href="#"><i>PART. 2-7(R)</i></a>
<b>Water Meter &amp; Fire Line Application</b>	A Water Meter and Fire Line Application is required for the installation of the public portion of the water service line, including the meter and box.	<a href="#"><i>PART. 2-7(S)</i></a>

## Part. 2-6(A) Demolition Permits

### Section. 2-6(A)(1) Applicability

Part. 2-6(A) applies to all demolition work, which requires a permit from Building and Safety Division. Under the Air Pollution Control Regulations, demolition of structures 75,000 cubic feet or larger requires an additional permit from the Environmental Health Department, Air Quality Program to insure that adequate measures are taken to control or prevent airborne particulate matter.

Structures 10,000 sq. ft or larger built or renovated prior to January 1st, 1980 require an approved Erosion and Sediment Control Plan and an approved Stormwater Control Permit for Erosion and Sediment Control from Stormwater Quality.

Demolition permits require the approval of the Building Safety Division, the Traffic Engineering Division, the Environmental Health Department's Air Quality Program, the Fire Department, the Water Utility Authority, the Historic Preservation Division, the Hydrology section, the Stormwater Quality section, and the Zoning Enforcement Division of the Planning Department

### Section. 2-6(A)(2) Procedures

1. The application form is obtained at permit desk, Building and Safety Division.
2. The applicant will need to obtain approval from the agencies indicated on the permit form, including:
  - a. *Code Administration Division and Fire Marshall's Office approvals are obtained at Building and Safety Division.*
  - b. *Traffic Engineering if canopies, fences or rails are required or if pedestrian traffic is to be rerouted. Traffic Engineering requires a site plan showing the locations of canopies, fences or rails and the method of rerouting pedestrian traffic in order to obtain approval.*
  - c. *Environmental Health Department, Air Quality Program for discussion and approval; or if structure is 75,000 cubic feet or larger, apply for Demolition Permit issued by the Environmental Health Department. The procedure is the same as for a surface disturbance permit which is described in Section 2-7.14.*
  - d. *Water Utility Authority for approval of fire hydrant use during demolition. Customer Services Division to arrange for meter for fire hydrant.*
3. Once agency approvals are obtained, the applicants returns the completed permit form to Development and Building Services for permit issuance and payment of fee.
4. The demolition permit issued by Building and Safety Division is effective for 180 days. An extension of 180 days may be granted upon written request.
5. Before beginning any demolition work, the applicant shall ensure all gas and electrical supply systems are disconnected by the New Mexico Gas Company and Public Service Company.

## **Part. 2-6(B) Floodplain Development Permit**

### **Section. 2-6(B)(1) Applicability**

Part 2-6(B) applies to all earthmoving, grading, paving, building additions, and new building construction in a Special Flood Hazard Area, SFHA. Compliance with the requirements of the Flood Hazard Ordinance is required of every applicant for subdivision, site development plan and/or building permit approval. Compliance is achieved by either demonstrating that the proposed project does not lie within a designated flood hazard area or by demonstrating adequate flood-proofing as required by the ordinance or by removing the site from a flood hazard area through the FEMA map revisions process.

### **Section. 2-6(B)(2) Procedures**

#### **2-6(B)(2)(i) Development within Flood Hazard Areas for Building Permits with “No Adverse Impact” and No Storm Drainage Improvements**

1. If any part of the development lies within the SFHA then applicant must submit the following to the hydrology section prior to approval of the Floodplain Development Permit:
  - a. A *Floodplain Development Permit Application*
  - b. A *Grading and Drainage Plan including calculations that demonstrate “No Adverse Impact” to the Base Flood Elevation, BFE. The applicant’s engineer must establish a BFE if one has not already been established by FEMA.*
  - c. A *Drainage and Transportation Information Sheet, DTIS.*
  - d. A draft “Elevation Certificate” is required for any portion of a new building within the SFHA.
  - e. If any portion of a new building is within the SFHA then prior to final approval of building occupancy, a final Elevation Certificate must be submitted to Hydrology with a DTIS.

#### **2-6(B)(2)(ii) Development within Flood Hazard Areas Involving Storm Drainage Improvements and/or Changes to Either BFEs or Floodplain Limits**

1. If any improvements are proposed within the existing Floodway boundary, the applicant must request a Conditional Letter of Map Revision (CLOMR) from FEMA prior to beginning any construction in the Floodway. Construction permits will not be issued for any project that includes work in the Floodway until the CLOMR is issued by FEMA.
2. If any improvements are proposed which modify the existing floodplain limits or base flood elevations, the applicant must provide a Grading and Drainage Plan including calculations that demonstrate no adverse impact to adjacent properties or provide written agreement from adversely impacted adjacent property owners accepting the specific adverse impacts being proposed. The applicant’s engineer must establish a BFE if one has not already been established by FEMA. The Floodplain development Permit and other construction permits will not be issued for any land disturbing activities within the current effective floodplain until the Grading

and Drainage plan has been approved by the City. The applicant has the option of requesting a CLOMR before beginning construction in order to better assure that FEMA will issue a LOMR after the improvements are constructed. The applicant is responsible for obtaining a LOMR removing the floodplain. City will not issue Building Permits for buildings when any portion of the building is in an effective floodplain, so the LOMR must become effective before Building Permits will be issued.

3. A Letter of Map Revision (LOMR) must be obtained from FEMA after construction is complete. When a CLOMR has been issued by FEMA, a portion or all of the SIA and financial guarantees for the improvements may be released prior to the LOMR being issued by FEMA, but the financial guarantee for the LOMR will not be released prior to the effective date of the LOMR. Submittal of a copy of the LOMR from FEMA is required for release of the balance of the financial guarantees and SIA's when issuance is a condition of release.
4. The following floodplain note must be placed on the plat if a LOMR has not been issued by FEMA: "Portions of the subject property lie within a designated area of special Flood Hazard as shown on the National Flood Insurance Program's "Flood Insurance Rate Map. Until such time that a LOMR is issued by FEMA, flood insurance may be required." The floodplains must be shown on the Plat, and the note should include the FIRM number and date.

## **Part. 2-6(C) Foundation Only Permits**

### **Section. 2-6(C)(1) Applicability**

Part. 2-6(C) applies to the construction of footings, foundation walls and any other construction up to and including a first floor slab, which require a Foundation Only Permit. A building permit is required before progressing with work beyond the foundation stage. The issuance of a foundation permit does not preclude the possibility that changes might be necessary to meet building code requirements or requirements of any other city ordinance or laws relating to construction.

### **Section. 2-6(C)(2) Procedures**

1. The applicant completes an application form at the building permit desk, Building Safety Division. Required application materials include:
  - a. *Two (2) sets of foundation plans drawn according to the structural requirements of the New Mexico Building Code and indicating type of construction. (Additional plans must be submitted for approval before plumbing or electrical work is started on building slab.)*
  - b. *A site plan that clearly identifies:*
    - i *The legal description and address - including any recent replats or lot line eliminations not yet recorded on existing zoning maps.*
    - ii *Parking and landscaping areas and setbacks. Actual parking spaces, access and circulation of vehicles and pedestrian, and types of landscaping need not be shown.*
    - iii *Indicate in writing proposed use of building (use must conform to zoning category), and total floor area to be occupied upon completion of building.*
    - iv *Height of building; if over 26' high, an elevation plan is required.*

- c. A Flood Hazard Area Site Plan that indicates:
  - i. If the building is located in a flood hazard area and if so, the flood-proofing measures to be used.
  - ii. The elevation of lowest finished floor above mean sea level.
  - iii. Temporary benchmark(s) on site.
  - iv. An approved drainage scheme or submittal (See [Article 2-3](#)).
2. Foundation plans are reviewed by Code Enforcement Division, Zoning Enforcement Section; Building Safety, Plans Review Section and by the Engineering Division of the Hydrology Section and Transportation Section.
3. If plans are approved, the applicant signs and has notarized the [Foundation Form B-27](#), which should be obtained from Building Safety Division.

## **Part. 2-6(D) Grading Permit and Paving Permit**

### **Section. 2-6(D)(1) Applicability**

Part. 2-6(D) applies to all grading which required a Grading Permit, including:

1. 1 acre or more;
  2. 500 cubic yards; or
  3. any grading to be done within or adjacent to a watercourse (defined as a major facility) during the months of July, August or September
- Paving an area larger than 2000 square feet shall require a Paving Permit. Repaving of existing paved areas in which no grading is planned is excluded.

Grading and Paving Permits are not required when the proposed grading and paving are a part of a Building Permit, but an approved Grading and Drainage plan is also required for a Building Permit.

### **Section. 2-6(D)(2) Procedure**

#### **2-6(D)(2)(i) [Pre-Design Conference](#)**

1. A pre-design conference should be scheduled with one of the Engineers from the Hydrology Section in order to evaluate the specific drainage requirements for the proposed grading and paving.

#### **2-6(D)(2)(ii) [Permit Application](#)**

1. Grading and Paving Permit applications are submitted to Development Review Services. Required application materials include:
  - a. The completed [Drainage and Transportation Information Sheet, DTIS](#)
  - b. Two copies of the required plans for review, including a Drainage Report and/or a Grading and Drainage Plan. See applicable checklist in [Chapter 6, Drainage, Flood Control and Erosion Control](#).
  - c. If parking or pedestrian paths will be striped with a paving permit, a dimensioned striping plan shall be approved by Transportation. See Chapter 7, Transportation Design for parking dimension requirements.
2. A nominal fee will be charged.

### 2-6(D)(2)(iii) [Inspection and Certification](#)

1. When grading or paving is associated with a Building Permit or Work Order, the authorized construction must be inspected for compliance with the approved plan and an Engineer's Certification must be submitted to Hydrology with a DTIS in order to receive either a Certificate of Occupancy or a release of Financial Guarantee.

## **Part. 2-6(E) Plumbing and Electrical Permits<sup>3</sup>**

### **Section. 2-6(E)(1) Applicability**

Part. 2-6(D) applies to all electrical, plumbing and mechanical work, which requires a Plumbing, Mechanical and Electrical Permit.

### **Section. 2-6(E)(2) Procedures**

1. Plumbing, mechanical, and electrical plans may be submitted for approval along with building plans.
2. The contractor or sub-contractor responsible for the specific work in question obtains the permit prior to beginning construction.
3. Electrical, plumbing, and mechanical permits are obtained through one of two methods following Building Safety Division approval of plans for the specific project.
  - a. Prior to beginning the work, the contractor completes an online permit form and submits it to [Building Safety Division's POSSE system](#). If approved, permit is issued electronically, or
  - b. The contractor or sub-contractor applies in person at Building Safety Division. If approved, permit is issued at fee payment.
4. Electrical, plumbing and mechanical permits for work not on approved plans are issued following plan approval by Building Safety. The procedure for obtaining these permits is essentially the same as that required for the building permit.

## **Part. 2-6(F) Relocation of Existing Buildings Permits**

### **Section. 2-6(F)(1) Applicability**

Part. 2-6(F) applies to the relocation of an existing building which requires the determination of necessary modifications to meet technical codes, a foundation permit, remodeling permit, and electrical, plumbing and mechanical permits, as appropriate. In addition, the Traffic Code ([Section 4.67](#)) requires a permit for oversize, overweight and/or overlength truckloads to be issued prior to actual moving of the building.

---

<sup>3</sup> The Water Utility Authority issues a sewer-tapping permit for connections to existing public sewer lines. The procedure for obtaining this permit is found in [Section 2-7.11](#).

## Section. 2-6(F)(2) Procedures

### 2-6(F)(2)(i) [Inspections](#)

1. Any appropriate building inspections are required to occur prior to the relocation of an existing building to determine. The purpose of these inspections is to determine any modifications that may be necessary to meet current mechanical, electrical and structural codes. The applicants contacts the Building Safety Division to scheduler inspections.
2. Any Required modifications found through the inspection shall be documented in an inspection report.

### 2-6(F)(2)(ii) [Foundation Permit](#)

1. The applicant is to submit two sets of drawings and two copies of any inspection report(s) to the Building Safety Division for a foundation permit. The submittal will be composed of:
  - a. *A foundation plan drawn to scale and pertinent foundation wall sections and details at a scale large enough to explain clearly the connection of the existing building to the new foundation.*
2. Plans are to clearly show all existing structural items which will bear on the new foundation and their anchorage.
3. Information provided in the team inspection report will determine whether or not a remodeling permit is necessary.

### 2-6(F)(2)(iii) [Remodeling Permit](#)

1. To receive a remodeling permit, the applicant will need to submit two sets of floor plans and two copies of the team inspection report to Building Safety.
2. Plans are to clearly show the modifications required by the team inspection report. All required modifications should be indicated by key notes on the floor plan that relate to a corresponding note in the titleblock which identifies and explains each numbered modification.

### 2-6(F)(2)(iv) [Oversize, Overweight and/or Overlength Truckloads Permit](#)

1. The applicant must obtain an oversize, overweight, and/or overlength truckload permit from the Traffic Engineering Division. The procedure for obtaining this permit is found in [Section 2-7.8](#).

## Part. 2-6(G) Sign Permits

### Section. 2-6(G)(1) Applicability

Part. 2-6(G) applies to most new signs erected in the city, which require a zoning permit and a building permit. The zoning regulations detail standards applicable to signs in all zones and defines the types of signs which do and do not require a zoning permit. All signs are required to comply with the provisions of current zoning regulations



## Section. 2-6(G)(2) Procedures

1. A zoning permit is required for the following types of new signs:
  - a. All sign faces having an area greater than 40 square feet.
  - b. All signs having a height in excess of eight feet.
  - c. All illuminated signs.
  - d. All signs with moving elements.
  - e. All free-standing and projecting-on-premise signs.
  - f. All portable signs.
  - g. All electronic signs, all changes to an existing sign so that it becomes an electronic sign or to change an existing electronic sign from an electronic message reader board sign to an electronic display panel sign.
  - h. Subdivision identification signs.
2. A building permit is required for the erection of all new signs except:
  - a. Signs less than 6 feet above grade.
  - b. Non-electric signs with an area of two (2) square feet or less.
  - c. Separate electrical permits are required for electric signs.
3. Sign permits can be obtained from the Zoning Section. Applications materials include:
  - a. A completed Application for Sign Permit.
  - b. Plans that describe the location, design and dimensions of the proposed sign.
  - c. A Sign Permit fee, paid at the permit desk, Building and Safety Division.
4. Plans for signs must conform to current zoning regulations and the sign, when finished, must conform to the approved plans.
5. A field inspection could be required prior to plan approval to investigate the proposed sign location and the number of signs existing on a site. Once the sign permit fee is paid, Building and Safety Division inspects the size and location of the sign against the submitted plans.
6. If the inspection determines the sign is in compliance with the plans, Building and Safety Division approves the sign. The permit goes into effect after the approval.
7. Building Permit, if required.
8. To apply for a building permit, structure plans for the sign need to be submitted to the Plans Review Section. If the sign is electrical, electrical plans should also be submitted to the Zoning Section for approval. A separate electrical permit is required.
9. The Permit will be issued when the structural plans are approved.
10. The sign will be inspected by the Inspection Section.
11. After final inspection, the applicant will notify the Zoning Section that the sign is ready for final inspection.

## Part. 2-6(H) Wall, Fence, and Retaining wall Permits

### Section. 2-6(H)(1) Applicability

Part. 2-6(H) applies to retaining walls 24" high or higher and for walls and fences higher than six feet, which require a Wall and Fence Permit. Walls or fences, or their footings proposed to be located in the public right-of-way, require the execution of an Revocable Permit or Encroachment Agreement ([Section 2-6.5](#)). The zoning regulations detail standards applicable to walls and fences in all zones. All walls and fences are required to comply with the provisions of current regulations.

### Section. 2-6(H)(2) Procedures

1. Permit Applications are submitted to Building Safety. Required application materials include:
  - a. *Plot plan.*
  - b. *Two (2) sets of plans showing:*
    - i *Height and location of walls or fences.*
    - ii *Existing and proposed walls or fences.*
2. Raised walls require certification by a New Mexico registered architect or engineer for the existing wall and a certified design for the raised portion.
3. New walls over six feet in height must be certified by a New Mexico registered architect or engineer.
4. Structural drawings are required for block walls.
5. Retaining wall drawings require an architect's or engineer's seal, and structural calculation.
6. If the wall, fence or retaining wall permits are related to a new or existing swimming pool, the barrier is regulated by the Swimming Pool Ordinance and Environmental Health Department.

## **ARTICLE 2-7 OTHER CONSTRUCTION PERMITS**

This section describes those permits integral to the development process which are established by legislation other than the Uniform Administrative and Technical Codes. Many of the permits and approvals are related to construction within the public right-of-way. Various city agencies administer the permits described in this section.

Permits established by the Uniform Administrative Code (Article 7-23 R.O.A. 1994) are detailed in [Section 2-5](#). These permits are related to construction on private property, their governing regulations are outlined in the Governing Regulation for Other Construction Permit Summary.

### **Part. 2-7(A) Air Contaminant Sources Registration**

#### **Section. 2-7(A)(1) Applicability**

Part. 2-7(A) applies to any commercial or industrial stationary source with actual emissions of more than two thousand pounds of any air contaminant per year or any amount of a hazardous air pollutant must be registered with the Environmental Health Department, Air Pollution Division, Air Quality Service Section, 11850 Sunset Gardens Rd. SW, within 180 days after initial start up. The purpose of registration is to provide the department information on sources of air contaminants for internal use and monitoring.

#### **Section. 2-7(A)(2) Procedure**

1. Pre-registration the applicant should discuss the project with staff of Environmental Health Department, Air Pollution Control Division to determine if registration is required.
2. If it is determine that registration is required, the applicant will need to complete the registration form.
3. Pay registration fee.

### **Part. 2-7(B) Authority-To-Construct Permit**

#### **Section. 2-7(B)(1) Applicability**

Part. 2-7(B) applies to the construction or modification of any commercial or industrial structure which, if it were uncontrolled, would result in an emission of air contaminants greater than ten pounds per hour or twenty-five tons per year (except five tons per year for lead; ten tons per year for hazardous air pollutants). An Authority-to-Construct permit is required to review/approve the construction or modification of such structures, this permit is issued by the Environmental Health Department, Air Pollution Control Division, Air Quality Service Section, 11850 Sunset Gardens Rd. SW.

## Section. 2-7(B)(2) Procedure

### 2-7(B)(2)(i) [Pre-Permit Application Review](#)

1. A Pre-Permit Application Review with staff of the Environmental Health Department, Air Pollution Control Division is required to determine if the permit is needed and, if so, to obtain permit forms and allow adequate time for the applicant to obtain of the permit prior to beginning construction.
2. The pre-permit review shall occur prior to completing permit application.
3. To schedule a pre-permit review the applicant needs to complete the Pre-Permit Meeting Request Form and submit it to Environmental Health Department.

### 2-7(B)(2)(ii) [Permit Application](#)

1. After the pre-permit application review has been completed, the applicant can complete the permit application.
  - a. *The information required by the permit application is highly technical and in most cases will require the assistance of a consultant.*
  - b. *A \$500 Permit fee must accompany application.*
2. The Environmental Health Department requires a 30-day review period for applications in order to determine completeness.
3. Once an application is deemed complete, there is a 60 day comment period.
4. Permit shall be issued or denied within 120 days (or 180 days if a public hearing is required) from the date that the application is deemed as complete.

## Part. 2-7(C) Barricade Permit

### Section. 2-7(C)(1) Applicability

Part. 2-7(C) applies to the required barricading of excavation of any accepted City right-of-way including the setback area or when construction or demolition work interferes with vehicular or pedestrian traffic. Barricade permits are required prior to excavation of any accepted City right-of-way, but are not required for work in previously unimproved City streets or rights-of-way; however, the construction zone is required to be barricaded in accordance with the requirements of the Traffic Code. The permit should be obtained from the Construction Coordination Division prior to application for excavation permits or sidewalk, driveway and curb and gutter permits, when appropriate.

### Section. 2-7(C)(2) Procedure

1. The applicant is to complete the [Barricade/Excavation Permit Application](#) and submit it along with a traffic handling plan that indicates detailed methods of handling traffic during construction to the Traffic Engineering Division
2. Once the traffic handling plan is approved, the Permit is issued. No fee is charged.
3. Inspection, as required, is automatic.

## **Part. 2-7(D) Blasting Permit**

### **Section. 2-7(D)(1) Applicability**

Part. 2-7(D) applies to all blasting work within the City Limits, which requires a blasting permit which is issued by the Albuquerque Police Department. Applicants for a blasting permit must present a Certificate of Insurance for \$500,000/1,000,000,/500,000 combined incident liability, structure damage, bodily injury and property damage.

### **Section. 2-7(D)(2) Procedure**

1. *Blasting permit forms* can be obtained from the Albuquerque Police Department Bomb Squad.
2. The applicant must obtain approval and sign off from the Fire Department and the City Engineer's office.
3. "One Call Service System" locates utility lines in the area. The applicant must call and wait forty-eight (48) hours from line spotting before conducting blasting work.
4. The completed blasting permit form is returned to Albuquerque Police Department for final approval and sign off. No fee is charged.

## **Part. 2-7(E) Encroachment Agreement (Approval To Place Private Infrastructure In A Public Easement)**

### **Section. 2-7(E)(1) Applicability**

Part. 2-7(E) applies to the agreement required to place private infrastructure in a public city easement. The agreement for this is similar to that of a revocable permit except that it involves placement of private infrastructure within a public easement.

### **Section. 2-7(E)(2) Procedure**

1. The applicant shall utilize the same procedures as for the Revocable Permit in Part. 2-7(M) with the following two exceptions:
  - a. Replace the Revocable Permit form with the *Encroachment Agreement Form*, which is located on the City of Albuquerque website.
  - b. There are no annual fees or a certificate of liability insurance required for an encroachment agreement.

## **Part. 2-7(F) Excavation Permit**

### **Section. 2-7(F)(1) Applicability**

Part. 2-7(F) applies to any excavation activity within the public right-of-way, for which the City Engineering Division requires a permit. Applicants for excavation permits should obtain a barricade permit from the Department of Municipal Development - Construction Coordination Division prior to application if the excavation work is within an accepted City right-of-way.

## Section. 2-7(F)(2) Procedure

1. In order to perform excavation work, the contractor must meet the following prerequisites:
  - a. *Appropriate State license for excavation work*
  - b. *Field Engineer approval*
  - c. *Post a \$10,000 Excavation Bond*
  - d. *\$10,000 Sidewalk, Drive-Pad, Curb & Gutter Bond*
  - e. *\$15,000 Bond Securing Payment of Permit Fees for the Department of Municipal Development.*
  - f. *Present evidence of \$2,000,000 liability insurance*
2. Applicants can apply for an Excavation Permit at the Construction Coordination Division
3. The permit clerk determines if the contractor is qualified and if his insurance and bonding are up-to-date before issuing permit.
4. If the street has been constructed, reconstructed, or overlaid within the last five years, the permit clerk will calculate the restoration fee as required by the Excavation Ordinance.
5. If the contractor meets the prerequisites, the permit is issued. The applicant pays charges prior to any activity within the public right-of-way.
6. When the excavation is backfilled, the inspector and/or contractor notifies the Construction Coordination Section and/or laboratory that the project is ready for compaction testing.
7. If compaction meets specifications, the Construction Coordination Section and/or laboratory advises the applicant that the street is ready for resurfacing if City is forecasting paving, or notifies the responsible contractor if repaving is to be done by a private contractor.
8. The Construction Services Division is notified when the resurfacing is complete; the permit is then filed for future warranty inspection.
9. All excavation work must be warranted for one (1) year. (Any excavation permit related to a work order needs to be coordinated with DRC and the Construction Department).

## Part. 2-7(G) Integrated Development Ordinance Approvals

### Section. 2-7(G)(1) Applicability

Part. 2-7(G) applies to all development activities that are authorized by the Integrated Development Ordinance (IDO).

### Section. 2-7(G)(2) Procedure

1. Administrative Decision
  - a. *The General Procedures in Section 14-16-6-4 (IDO) and the application specific procedures in Section 14-16-6-5 (IDO) apply to all administrative decisions. The Procedures Summary Table in Section 14-16-6-1 (IDO) indicate what type of notice is required, and which City bodies review and make a decision on the application.*
2. Decisions Requiring a Public Meeting and/or Hearing
  - a. *The General Procedures in Section 14-16-6-4 (IDO) and the application specific procedures in Section 14-16-6-6 (IDO) apply to all decisions requiring a public meeting or hearing. The Procedures Summary Table in Section 14-16-6-1 (IDO) indicate what type of notice is required, and*

which City bodies review and make a decision on the application, and in which cases a public meeting is held or a public hearing is required.

3. Policy Decisions
  - a. The General Procedures in Section 14-16-6-4 and the application specific procedures in Section 14-16-6-7 apply to all policy decisions. The Procedures Summary Table in Section 14-16-6-1 indicate what type of notice is required, and which City bodies review and make a decision on the application.

## **Part. 2-7(H) Median Cuts and Left Turn Lane Approval**

### **Section. 2-7(H)(1) Applicability**

Part. 2-7(H) applies to any proposed median cuts and left turn lanes which require City approval to insure that spacing requirements, the type of development, internal circulation and existing or projected traffic operating conditions are considered. See [Chapter 7, Transportation Design](#) for Median and Turn Lane design requirements.

### **Section. 2-7(H)(2) Procedure**

1. To obtain median cut and left turn lane approval, the applicant submits a written request to the City Engineer. The request shall include:
  - a. The name and address of applicant
  - b. The proposed use of property
  - c. A Traffic Scoping Report (see [Chapter 7, Transportation Design](#))
  - d. A Site plan showing the proposed buildings, parking and driveways
2. If the City Engineer approves the request, a work order must be obtained for construction. Work orders require engineered plans and may be obtained from DRC.
3. Depending on the size of the development, a traffic impact study may be required for a median opening to be created. See the Traffic Impact Study, [Chapter 7, Article 7-6](#) for additional information.
4. The cost of new median cuts and left turn lanes is borne by the applicant.
5. Application and approval of median cut and/or left lane may be included with a Site Plan-DRB submittal.

### **Section. 2-7(H)(3) Additional approvals**

1. Approval by the New Mexico Department of Transportation is required for all median openings along state-owned and maintained roadways. Median openings on NMDOT-owned and maintained facilities must follow NMDOT design criteria
2. Limited access roadways are shown on the MRMPO Inventory of Roadway Access Limitations and carry restrictions related to intersection spacing and driveway access. Limited Access Roadways are typically located on principal arterials or on the interstate/frontage road system. This restriction may apply to the entire roadway length or individual segments. To learn the precise boundaries for Limited Access Roadways contact the Traffic Engineer in the Transportation Division or visit the MRCOG website at <https://www.mrcog-nm.gov/transportation>.



## **Part. 2-7(I) Oversize, Overweight and/or Over Length Truckloads Permit**

### **Section. 2-7(I)(1) Applicability**

Part. 2-7(I) applies to for the movement or operation of oversize, overweight and/or over length vehicles on City streets. The **New Mexico Vehicle Laws, Section 64-23-13 through 64-23-20**, define the dimensions and weight of vehicles which require this permit.

### **Section. 2-7(I)(2) Procedure**

1. The applicant complete the *Oversize, Overweight and/or Over Length Truckloads permit form*.
2. The applicant takes the permit form to the Watch Commander's office at the Albuquerque Police Department to determine if licensed escort service is needed according to the requirements of State Statutes and for sign off.
3. Once the Watch Commander's signature has been obtained, the applicant returns the permit form to the Traffic Engineering Division for signature of the Traffic Engineer or designee.

## **Part. 2-7(J) PERMIT SO-19 (PRIVATE STORM DRAIN FACILITIES WITHIN A CITY RIGHT-OF-WAY AND/OR EASEMENT)**

### **Section. 2-7(J)(1) Applicability**

Part. 2-7(J) applies to circumstances in which a drainage plan developed for a particular property involves either discharge directly into a public facility or across a portion of a public right-of-way to a public facility. Examples include connections to the back of an existing storm inlet or construction of side-walk culverts. When such solutions are employed, the construction within the public right-of-way must meet City standards and the owner of the property is responsible for maintenance of the facility. An SO-19 Permit is required for construction in the public right of way in these situations.

An SO-19 Permit should not be used for a project that also requires a Work Order. The private storm drain facilities should be shown on the Work Order Plans instead.

### **Section. 2-7(J)(2) Procedures**

1. A Grading and Drainage Plan showing the proposed improvement and including the standard SO-19 notes must be submitted to the Hydrology Section with a Drainage and Transportation Information Sheet, DTIS. The G&D Plan must be approved for SO-19 Permit by a letter from Hydrology. Then the contractor must obtain an Excavation and/or Barricading Permit prior to Construction. Instructions for coordinating the work with a City inspector are included in the SO-19 notes. For properties which employ drainage solutions involving the public right-of-way, the required documentation must be accomplished prior to issuance of a building permit.

2. After construction is complete and prior to issuance of a Certificate of Occupancy, an Engineer's Certification must be submitted to the Hydrology Section with a DTIS.

## **Part. 2-7(K) Private Use of Fire Hydrants**

### **Section. 2-7(K)(1) Applicability**

Part. 2-7(K) applies to the private use of fire hydrants. Connections to fire hydrants at any location are prohibited without written permit from the Customer Service Division of the ABCWUA except for City of Albuquerque street sweepers, street rollers and Fire Department vehicles. All other private and governmental users - federal, state, county, city and military - must have a permit.

Two types of permits are issued. A Designated Permit allows the permit holder to use any of any designated hydrants located within the City and County limits. A special use meter is attached to these hydrants and they are painted red.

A Special Permit is required for private use of other fire hydrants not noted above. Fire hydrants located within 300 feet of any apartment house, school or hospital cannot be used.

### **Section. 2-7(K)(2) Procedure**

#### **2-7(K)(2)(i) Designated Permit**

1. To obtain a Designated Permit, the applicant completes the [\*Application for Water Service Form\*](#) and submits it to the Customer Service Division.
2. The application must be approved by the Customer Services Division before any water can be withdrawn by the applicant
3. Upon approval of the application form, the applicant shall pay a deposit fee and is then issued a Designated Permit, Monthly Usage Forms, special key, and permit wrench. The deposit is refundable when the key and hydrant wrench are returned. The Monthly Usage Form is used by the permit holder to record the readings of the meter each time water is withdrawn from the designated hydrant.
4. The designated permit is to be located on the vehicle or on the premises. The permit shows permit number, date, company name, company address and vehicle license number.
5. The applicant is to report the previous month's use of hydrant on the Monthly Usage Form. The form is to be mailed to the Customer Services Division before the 25th day of the succeeding month.
6. All water withdrawn from a designated fire hydrant is charged at the current commodity rate. In addition, permit holders are charged a maintenance fee per month or portion thereof.

**Section. 2-7(K)(3) Fire Hydrant Special Use Permit, refer to the [ABCWUA's Water and Sewer Rate Ordinance](#)**

1. To obtain a Fire Hydrant Special Use Permit, the applicant completes the [Application for Water Service form](#) and the [Special Use Request Form](#). The applicant must state reasons for use of a hydrant meter, the location of the meter, and the length of time the meter is to be used.
2. Upon approval of the application, the Applicant must pay all applicable fees including:
  - a. A *Special Use Connection Fee for each permit issued; and*
  - b. A *meter deposit. The deposit is refundable when the meter is returned to the Water Operations Field Office in excellent condition. Damages will be assessed and deducted from the meter deposit.*
3. Once all applicable fees are paid, the permit holder is issued rules and procedures for hydrant use and a wrench for opening the fire hydrant. The meter(s) are to be obtained from the Customer Services Division Meter Shop.
4. The Special Use Permit(s) shall be located in the permit holder's vehicle or on the premises at all times.
5. The permit holder must record the readings of the meter each time water is withdrawn on the Monthly Usage Form. The form shall be mailed to the Customer Services Division before the 25th day of the succeeding month.
  - a. *Permit holders should check to see that water meters register properly by asking to see the record showing meter reading before and after drawing water. Meters not registering properly should be reported to the Customer Services.*
6. All water withdrawn from a fire hydrant under a special permit is charged at the current commodity rate.
7. In addition to usage fees, the permit holder(s) is charged a monthly maintenance fee of \$32.00 per month or portion thereof.
8. The Customer Service Division may revoke a fire hydrant permit in the event of improper permit identification, or failure to furnish such equipment, permits or Monthly Usage Forms, as specified.

## **Part. 2-7(L) Public Swimming Pool Operating Permit**

### **Section. 2-7(L)(1) Applicability**

Part. 2-7(L) applies to the operation of public swimming pools. Public Swimming Pool Operating Permits must be renewed annually after inspection of the swimming pool.

The Swimming Pool Ordinance establishes the permit and sets design, construction, operation and maintenance requirements. Construction plans are reviewed by the Environmental Health Department representative during the review process for the building permit for swimming pools. Information for obtaining a building permit for a public swimming pool is found in [TABLE 2.6.2](#).

### **Section. 2-7(L)(2) Procedure**

1. Prior to opening a swimming pool for public use, the applicant must call the Environmental Health Department to request an inspection.

2. If the swimming pool meets the construction, operation, and maintenance requirements established by the Swimming Pool Ordinance, an operating permit will be issued.
3. The City assesses an inspection fee for the initial swimming pool permit and an annual inspection fee for renewal of the operating permit, due April 15 of each year.

## **Part. 2-7(M) Revocable Contract (Approval To Place Private Infrastructure In The Public Right-Of-Way)**

### **Section. 2-7(M)(1) Applicability**

Part. 2-7(M) applies to the construction of private walls, footings, fences, signage, or any other privately owned infrastructure in the public right-of-way, which require City approval and the execution of an revocable permit between the City and the property owner to allow private use of public right-of-way on a conditioned, revocable basis. The contract ensures to the public the use of the right-of-way for public purposes as needed, in that the applicant contracts to remove the encroaching structure within a specific time (normally 72 hours) upon notification by the City. The applicant is also responsible for indemnifying the City from any negligent actions by the applicant. The revocable permit must be executed prior to issuance of the building permit for walls, fences or retaining walls to be placed in the public right-of-way.

Walls, fences 3 feet high and higher and retaining walls 18 inches high and higher require a wall permit from the Code Administration Division (See [Part. 2-6\(H\)](#)). Walls and fences which vary in height from the regulations of the Integrated Development Ordinance require Zoning Hearing Examiner approval through a variance per the IDO procedure. (See IDO, Section 6-6(L), 6-6(M), 6-6(N)).

### **Section. 2-7(M)(2) Procedure**

1. The applicant shall complete the [Revocable Permit form](#) and all required application materials to the City Engineer for approval. The following application materials shall become part of the agreement.
  - a. *Exhibit by licensed surveyor indicating:*
    - i *The property address and legal description*
    - ii *The location of existing curbs*
    - iii *Property line locations*
    - iv *The location and width of sidewalks*
    - v *The location, height and width of encroachment*
    - vi *The location of water meters*
    - vii *Square footage of encroachment within public right-of-way*
    - viii *Certificate of Liability Insurance for \$1,000,000 with City of Certificate Holder*
  - b. *The sketch becomes a part of the agreement.*
2. The applicant must obtain approval from the following:
  - a. *The City Engineer*
  - b. *Zoning Enforcement Officer*
  - c. *Traffic Engineer*
  - d. *Code Administration Division*

3. Upon approval, the applicant returns the contract and sketch to the City Engineer for processing and recordation with County Clerk. The applicant shall pay a fee to the City for recordation done with annual fee based on square footage of encroachment.
4. The Applicant shall be advised by phone when processing is complete.
5. The completed agreement shall be recorded with County Clerk and filed with City Clerk.
6. Annual fee for permit is paid every year thereafter.
7. Revocable permit must be renewed every 10 years

## **Part. 2-7(N) Sewer Tapping Permit**

### **Section. 2-7(N)(1) Applicability**

Part. 2-7(N) applies to the required permits for tapping into existing sewer lines. Sewer line construction from the main line connection to the structure are generally authorized under the plumbing permit issued by the Code Administration Division (CAD).

### **Section. 2-7(N)(2) Procedure**

1. Sewer tapping permits are issued only to licensed and bonded contractors.
2. To apply for a Sewer Tapping Permit, the applicant completes the [permit form](#) at the ABCWUA, located in the Plaza Del Sol building, 600 2nd St. NW, Suite 201.
3. Applicants for sewer tapping permits must also obtain a barricade permit (see [Part. 2-7\(C\)](#)) and an excavation permit (see [Part. 2-7\(F\)](#)) prior to tapping.
4. The engineer issuing the permit will provide instructions related to the tapping.
5. The applicant is required to pay a permit fee.
6. A copy of the sewer tapping permit must be presented to the Code Administration Division plumbing inspector located at Plaza Del Sol Building, 600 2nd St., N.W., at the time of line inspection.

## **Part. 2-7(O) Sidewalk, Drive Pad and Curb and Gutter Permits**

### **Section. 2-7(O)(1) Applicability**

Part. 2-7(O) applies to the construction of sidewalks, drive pads or curb and gutter. All curb and gutter work must be performed by a properly licensed contractor. All other work must be performed either by a properly licensed contractor or the homeowner following the procedures outlined. Sidewalks, drive pads and curb and gutter shall be designed and constructed per [Chapter 7 - Transportation Design](#).

### **Section. 2-7(O)(2) Procedure**

1. To construct sidewalks, drive pads or curb and gutter the contractor must meet the following pre-requisites:
  - a. *Appropriate State license for concrete work*
  - b. *City Engineer approval*
  - c. *Post a \$5,000 maintenance bond*

- d. Post a \$1,000 fee bond, if applicant wishes to establish a charge account with the City to be billed for fees on a monthly basis.
      - e. Present evidence of \$5,000,000 liability insurance bond
2. Homeowners constructing sidewalks must meet the following pre-requisites:
  - a. City Engineer approval
  - b. Post a \$500 maintenance bond
  - c. Present evidence of \$10,000 liability insurance (homeowner's policy is sufficient)
3. City Engineer approval is granted through the DRC work order process as described in 2-3 for Major Infrastructure improvements and as follows for minor work.
  - a. Provide a dimensioned Site Plan showing property lines, existing curb and gutter, sidewalk, drive pad, and proposed sidewalk, curb and gutter, and drive pads.
  - b. City Engineer will review and issue approval.
4. Qualified applicants can apply for a permit at Construction Coordination. The permit clerk determines if the contractor is qualified and if insurance and bonding are up-to-date before issuing permit.
  - a. Applicants for these permits should obtain a barricade permit (see [Part. 2-7\(C\)](#)) from the Construction Coordination Division prior to application.
  - b. An excavation permit (see [Part. 2-7\(F\)](#)) is also required and is issued simultaneously with the sidewalk, drive pad, and curb and gutter permit.
5. If the contractor meets the pre-requisites the permit is issued. The Applicant must pay the permit fee.

## **Part. 2-7(P) Solar Rights Permit**

### **Section. 2-7(P)(1) Applicability**

Part. 2-7(P) applies to the permitting process that grants a property owner's right to install solar hot water heating panels or photovoltaic panels and the protections that ensure abutting property owners do not construct improvements or install landscaping that would materially reduce the effectiveness of those solar panels.

### **Section. 2-7(P)(2) Procedure**

1. Application for a solar permit is through the office of the Zoning Hearing Examiner, located in the Development and Building Services Center (DBSC). Solar Permit Procedures are established pursuant to [Part 14-11-7 of ROA 1994](#). This DPM outlines the required submittal materials.
2. To apply, the applicant submits the a [application form](#) and two (2) copies of the following application material to the Development and Building Services Center twenty-two (22) days prior to the scheduled Zoning Hearing Examiner public hearing. An application fee is required.
  - a. Plans of the proposed solar energy system, including:
    - i The type of solar collector and any heat storage and distribution facilities.
    - ii Calculations and sum total as to collection and beneficial use of heat, expressed in BTU's and solar fraction.
  - b. Site Plans showing:





### **Section. 2-7(R)(2) Procedure**

1. The applicant is to discuss the project with a representative of the Environmental Health Department, Air Quality Program to determine need and type of Fugitive Dust Permit and appropriate site specific dust control measures for controlling airborne particulate matter.
2. If a Fugitive Dust Permit is required, the applicant shall complete the appropriate *Fugitive Dust Application form* provide a copy of the site map and payment of fees.
3. The applicant must obtain requisite signatures from the project owner/ operator, permittee and/or responsible person as indicated on the application form. Allow up to 10 business days for application review for surface disturbance of 25 acres or less and 20 business days for surface disturbance of greater than 25 acres.
4. Permission is granted for surface disturbance upon issuance of the Fugitive Dust Permit.

## **Part. 2-7(S) Water Meter and Fire Line Application**

### **Section. 2-7(S)(1) Applicability**

Part. 2-7(S) applies to the new construction of water service and fire lines. Methods of installing the public portion of the water service line, including the meter and box, are discussed in *Chapter 6, Water System Design.*

### **Section. 2-7(S)(2) Procedure**

1. The applicant completes *Application for Water Service Form* obtained at the ABCWUA in the City County Building, 1st floor.
2. A water tap is required for all water service connections that are less than 3".
3. Installation of fire hydrants and/or fire lines shall be installed with a ABCWUA mini work order.
4. The applicant pays the fees required by the ABCWUA. Work order is issued for installation of water meter. Regular billing begins when water meter is installed.

## ARTICLE 2-8 DRAINAGE AND TRANSPORTATION SUBMITTALS

This section presents procedures for making Drainage and Transportation submittals. General criteria established by the City for review of those submittals are also presented.

Guidelines for preparation of Drainage and Traffic Circulation Layout Transportation submittals are presented in DPM [Chapter 6, Part 6-2\(C\)](#) and [Chapter 7, Part 7-3\(C\)](#), respectively. The material and information required for a complete submittal can be determined by referring to the appropriate Chapter.

### Part. 2-8(A) Drainage and Transportation Submittal Approval Procedures

1. The following are procedures and guidelines established by the City Engineer's Office for the review of Drainage and Transportation Submittals.
  - a. *All Submittals and follow-up correspondence should be submitted to the City Engineer's Office. For record keeping purposes a Drainage & Transportation Information Sheet (DTIS) must be provided with the subject transmittal. The latest version can be obtained from Albuquerque Development and Building Services Center website. All submittals required for building permit, preliminary plat, site development plan, sector plan, etc. approvals, must be processed through the City Engineer's Office. Submittals included with E.P.C., DRB and building permit plans will not be reviewed by the City Engineer's Office with the subject application. In order to obtain the review of the City Engineer's Office, each submittal made in support of a specific action shall be submitted separately to the City Engineer's Office for processing and review.*
  - b. *Correspondence related to Drainage and Transportation Submittals must reference the file number assigned by the City Engineer's Office upon submittal (for example, E17D025). This file number shall also be referenced on all re-submittals. The use of the file number facilitates the processing and tracking of submittals and related correspondence.*
  - c. *Upon receipt of a Drainage or Transportation submittal a file number will be assigned and the submittal will be logged in for review. The submittal will be added to a list that identifies its status in the review process.*
  - d. *Drainage and Transportation Submittals that do not include a DTIS, vicinity map, legal description, engineer's seal for Drainage and engineer's or architect's seal for Transportation, date and other major items identified on the appropriate DPM format guideline will not be accepted. If submittal information is incomplete, the applicant will be notified by the City Engineer's Office stating what information is missing. Only after the information is deemed complete will a submittal be accepted for review.*
  - e. *If a submittal is required for a DRB approval, the DRB number (if available) must be included on the DTIS as well as copies of the required infrastructure list (proposed, draft or final), plat and/or site plan. If a submittal is for Certificate of Occupancy, the Building Permit number must be included on the DTIS form and attach a copy of the permit.*
  - f. *It is the policy of the City Engineer's Office to make responses to new submittals, resubmittals, and follow-up correspondence as soon as possible*

but not more than ten working days after a complete submittal has been received by that Office.

- g. All revisions made to a particular submittal must be signed, sealed and dated by the Architect of Record and with revisions clearly noted.
- h. Approved Drainage and Transportation Submittals are in effect for a period of one year from the date of approval. After one year, if no significant development has taken place, a resubmittal will be required and must reflect all changes in conditions and/or City requirements since the date of last approval.
- i. Questions concerning the preceding items should be directed in writing to the City Engineer's Office.

## **Part. 2-8(B) Drainage Facilities and Roadway Improvements Construction Agreement and Financial Guarantee**

Section 9D of the City Drainage Ordinance (Article 7-9 R.O.A. 1994) states that "if the construction of such (drainage) facilities is a condition of plat approval or building permit issuance, then financial guarantees of such construction satisfactory to the City Engineer shall also be provided as a prerequisite." In those instances where financial guarantees are required, the developer enters into an agreement with the City assuring the construction of such facilities. The form of agreement and the nature of acceptable financial guarantee is dependent on the circumstances involved. (See DPM [Chapter 5 Recordable and Development Documents](#) for sample documentation used for such guarantees).

## **Part. 2-8(C) Forms and Certificates**

Current copies of forms and certificates such as the Drainage and Transportation Information Sheet, conference recap sheet, Floodplain development Permit, Elevation Certificate, and other pertinent documents can be obtained from the Albuquerque Development and Building Services Center. Requests for approvals of Site Development Plans and/or Subdivision Plats shall be accompanied by a drainage submittal. The particular nature, location and scope to the proposed development defines the degree of drainage detail. One or more of the following levels of submittal may be required based on the following:

1. Conceptual Grading and Drainage Plan: Required for approval of Site Development Plans greater than five (5) acres and Sector Plans.
2. Drainage Plans: Required for building permits, grading permits, paving permits and site plans less than five (5) acres.
3. Drainage Report: Required for subdivision containing more than ten (10) lots or constituting five (5) acres or more.

## ARTICLE 2-9 DPM VARIANCES

### Part. 2-9(A) Variance to DPM Standards

#### Section. 2-9(A)(1) Applicability

A variance to design standards may be sought in order to cover unusual circumstances or alternative design concepts. Any variance or exception from a standard in the DPM is reviewed by the DRB per IDO section 14-16-6-6(L).

#### Section. 2-9(A)(2) Procedure

See IDO section 14-16-6-6(L)(2) for more detailed procedure requirements.

##### 2-9(A)(2)(i) [Neighborhood Meeting](#)

At the neighborhood meeting, the applicant shall provide information about the proposed project, including but not limited to the scope of uses, approximate square footages for different uses, general site layout, design guidelines, architectural style, conceptual elevations, and conceptual landscaping plans.

##### 2-9(A)(2)(ii) [Application](#)

1. An application form and the appropriate fees can be found on the City website as well as at the Albuquerque Development and Building Services Center. The submittal shall include:
  - a. A scale drawing showing the location of the proposed variance with appropriate dimensions.
  - b. Letter describing, explaining, and justifying the request per the criteria in IDO Section 14-16-6-6(L)(3) and compliance with the DPM.
2. Submit a completed application form and fee. A public hearing by the DRB will be scheduled within 7 days after the date of acceptance of the application and proper public notification per IDO requirements.

##### 2-9(A)(2)(iii) [Development Review Board Public Hearing](#)

1. The public hearing gives the general public and area resident's an opportunity to discuss and speak for or against the request and to elicit additional information which may have a bearing on the request. The applicant or agent must be present at the hearing to speak on behalf of the request and respond to questions.
2. Decision by the DRB may be deferred or continued if additional information or additional public notice is deemed necessary.
3. The DRB's decision on the request may be to approve, approve with conditions, or deny the request.
4. The decision is final unless appealed to the Land Use Hearing Officer (LUHO). See IDO for Appeal Procedures.

## **Part. 2-9(B) Sidewalk Variance or Waiver**

The Sidewalk Ordinance states that “all properties within the City of Albuquerque shall have sidewalk, drivepad, curb ramps, and curb and gutter in accordance with the standards set forth by the Sidewalk Ordinance, unless a variance from these standards is allowed”. In addition, sidewalk design shall be in accordance with the criteria presented in 14-16-5-3(D) of the IDO and Chapter 7 of the Development Process Manual. General sidewalk design criteria promotes mobility, safety and comfort of the pedestrian and allows adequate pedestrian access to abutting property.

### **Section. 2-9(B)(1) Applicability:**

While the City encourages compliance with the standards and design criteria, there are certain circumstances under which a variance from the standards and design criteria is appropriate. The sidewalk variance procedure was established to provide for possible departure from normal standards under specific circumstances and to protect unique characteristics of certain neighborhoods. Any property owner who wishes to install a sidewalk which does not conform to the standards in the Sidewalk Ordinance (6-5, ROA) and the design criteria in the DPM, Chapter 7 must apply for a variance.

While the City encourages compliance with the standards and design criteria, there are certain circumstances under which a variance from the standards and design criteria is appropriate. The sidewalk variance procedure was established to provide for possible departure from normal standards under specific circumstances and to protect unique characteristics of certain neighborhoods. Any property owner who wishes to install a sidewalk which does not conform to the standards in the Sidewalk Ordinance (6-5, ROA) and the design criteria in the DPM, Chapter 7 must apply for a variance.

Exceptions:

A variance to the use of material other than standard material as described in Chapter 7 requires the review and approval of the City Engineer.

### **2-9(B)(1)(i) Governing Regulations:**

#### ***2-9(B)(1)(i)(a) Sidewalk Variance applications are evaluated based on the following criteria and are approved if all of the following is met:***

1. The area is of low-intensity land use to an extent that the normal installation of sidewalks will not contribute to the public welfare, and the absence of a sidewalk will not create a gap in an existing sidewalk system extended to 1 or more sides of the subject property or area.
2. The City's right-of-way is insufficient in width to permit the construction of a sidewalk of standard dimension and placement, but there is sufficient right-of-way to meet minimum ADA or PROWAG guidance.
3. The adjoining sidewalks are non-standard as to width and/or location, and the Variance would enable the new and existing sidewalks to match in width and/or location, or could create a smooth transition between areas of different width and/or character.

**2-9(B)(1)(i)(b) Sidewalk Waiver applications are evaluated if the previous criteria is not met however one or more of the following criteria is also met.**

1. The area or site has been recognized as having historical, archeological, and/or architectural significance by the City of Albuquerque, the State of New Mexico, or the United States of America and in order to maintain such historical, archeological, and/or architectural significance a variance is appropriate.
2. There are pre-existing obstructions that cannot be easily or economically relocated or should not be altered, such as mature trees, grades, fills, water courses, natural topographic features or man-made obstructions.
3. The established neighborhood character or mature landscaping on the site would be damaged to a degree that outweighs the public utility of the normal sidewalk requirement.
4. Creation of a short stub street, cul-de-sac, or local access street with no more than an ADT of 50.

**2-9(B)(1)(ii) Procedure**

**2-9(B)(1)(ii)(a) Neighborhood Meeting**

At the neighborhood meeting, the applicant shall provide information about the proposed project, including but not limited to the scope of uses, approximate square footages for different uses, general site layout, design guidelines, architectural style, conceptual elevations, and conceptual landscaping plans.

**2-9(B)(1)(ii)(b) Application**

1. An application form and the appropriate fees can be found on the City website as well as the Albuquerque Development and Building Services Center.
2. The submittal shall include:
  - a. A scale drawing showing the location of the proposed variance or waiver with appropriate dimensions.
  - b. Letter describing, explaining, and justifying the request per the criteria in IDO Section 14-16-6-6(L)(3) and compliance with the DPM.
3. Submit a completed application form and fee. A public hearing by the DRB will be scheduled within 7 days after the date of acceptance of the application and proper public notification per IDO requirements.

**2-9(B)(1)(ii)(c) Development Review Board Public Hearing**

1. The public hearing gives the general public and area resident's opportunity to discuss and speak for or against the request and to elicit additional information which may have a bearing on the request. The applicant or agent must be present at the hearing to speak on behalf of the request and respond to questions.
2. Decision by the DRB may be deferred or continued if additional information or additional public notice is deemed necessary.
3. The DRB's decision on the request may be to approve, approve with conditions, or deny the request.
4. The decision is final unless appealed to the LUHO. See IDO for Appeal Procedures.

### *2-9(B)(1)(ii)(d) Sidewalk Permit*

1. Approval of a sidewalk variance does not constitute approval of plans for a sidewalk permit. The Letter of Advice must accompany the traffic site plan and/or sidewalk permit application.

## **Part. 2-9(C) Temporary Sidewalk Deferral**

### **Section. 2-9(C)(1) Applicability**

A developer has the option to defer the construction of sidewalks until the end of lot construction within a subdivision. The eventual construction of sidewalks shall be financially assured through the use of an Infrastructure Improvement Agreement (IIA) per DPM section 2-3.

### **Section. 2-9(C)(2) Governing Regulations:**

Sidewalks shall be designed and constructed be in accordance with the criteria presented in 14-16-5-3(D) of the IDO and Chapter 7 of the Development Process Manual.

### **Section. 2-9(C)(3) Procedure**

#### *2-9(C)(3)(i) [Neighborhood Meeting](#)*

At the neighborhood meeting, the applicant shall provide information about the proposed project, including but not limited to the scope of uses, approximate square footages for different uses, general site layout, design guidelines, architectural style, conceptual elevations, and conceptual landscaping plans.

#### *2-9(C)(3)(ii) [Application](#)*

1. An application form and the appropriate fees can be found on the City website as well as the Albuquerque Development and Building Services Center.
2. The submittal shall include a scale drawing showing the location of the deferred sidewalk with appropriate dimensions.
3. Submit a completed application form and fee. A public hearing by the DRB will be scheduled within 7 days after the date of acceptance of the application and proper public notification per IDO requirements.

#### *2-9(C)(3)(iii) [Development Review Board Public Hearing](#)*

1. The public hearing gives the general public and area resident's opportunity to discuss and speak for or against the request and to elicit additional information which may have a bearing on the request. The applicant or agent must be present at the hearing to speak on behalf of the request and respond to questions.
2. Decision by the DRB may be deferred if additional information or additional public notice seems necessary.
3. The DRB's decision on the request may be to approve, approve with conditions, or deny the request.



4. The decision is final unless appealed to the LUHO. See IDO for Appeal Procedures.

## **Section. 2-9(C)(4) Stub Street/ Cul-de-Sac Variance**

### **2-9(C)(4)(i) Applicability:**

The street network in new subdivisions shall be created through block standards in IDO Subsection 14-16-5-4(E) and DPM Chapter 7. Stub streets and cul-de-sacs that terminate the road are prohibited, with the following exceptions:

1. Cul-de-sacs are allowed where necessary to avoid those types of sensitive lands listed in Section 14-16-5-2(C), or where vehicular safety factors make a connection impractical, including but not limited to size or shape or lots, topography, surrounding development patterns, and physical characteristics.
2. Permanent stub streets are allowed only where a connection to an existing street and a future road extension is not possible or feasible. Where allowed, stub streets are limited to 150 feet in length.
3. Mid-block "bubble" cul-de-sacs without throats are allowed.
4. Whenever cul-de-sacs are created, one 20 foot wide pedestrian access/public utility easement shall be provided between the cul-de-sac head or street turnaround and the sidewalk system of the closest adjacent street or walkway, unless the city engineer determines that public access in that location is not practicable due to site or topography constraints.

### **2-9(C)(4)(ii) Governing Regulations:**

Although stub street and cul-de-sac street configurations shall be avoided in layout of new streets, if they are necessary and meet the previous exceptions, they shall be designed per DPM Chapter 7.10 after a variance is granted by DRB.

### **2-9(C)(4)(iii) Procedure**

#### **2-9(C)(4)(iii)(a) Neighborhood Meeting**

At the neighborhood meeting, the applicant shall provide information about the proposed project, including but not limited to the scope of uses, approximate square footages for different uses, general site layout, design guidelines, architectural style, conceptual elevations, and conceptual landscaping plans.

#### **2-9(C)(4)(iii)(b) Application**

1. An application form and the appropriate fees can be found on the City website as well as the Albuquerque Development and Building Services Center.
2. The submittal shall include:
  - a. A scale drawing showing the location of the proposed variance with appropriate dimensions.
  - b. Letter describing, explaining, and justifying the request per the criteria in IDO Section 14-16-6-6(L)(3) and compliance with the DPM.

3. Submit a completed application form and fee. A public hearing by the DRB will be scheduled within 7 days after the date of acceptance of the application and proper public notification per IDO requirements.

#### ***2-9(C)(4)(iii)(c) Development Review Board Public Hearing***

1. The public hearing gives the general public and area resident's opportunity to discuss and speak for or against the request and to elicit additional information which may have a bearing on the request. The applicant or agent must be present at the hearing to speak on behalf of the request and respond to questions.
2. Decision by the DRB may be deferred if additional information or additional public notice seems necessary.
3. The DRB's decision on the request may be to approve, approve with conditions, or deny the request.
4. The decision is final unless appealed to the LUHO. See IDO for Appeal Procedures.

### **Section. 2-9(C)(5) Vacation Of Right-Of-Way Or Easement**

#### ***2-9(C)(5)(i) Applicability:***

This section corresponds to the procedure outlined in the IDO section 14-16-6-6(K). It applies to all applications to vacate a public right-of-way or easement, including but not limited to streets, alleys, and easements that are owned by or under the control of the City, as well as applications to vacate a private way or easements shown on a recorded plat.

#### ***2-9(C)(5)(ii) Governing Regulations:***

Rights of way and Easements may be vacated if all of the following criteria is met:

1. The public welfare is in no way served by retaining the right-of-way or easement
2. There is a net benefit to the public welfare because the development made possible by the vacation is clearly more beneficial to the public welfare than the minor detriment resulting from the vacation
3. There is no convincing evidence that any substantial property right is being abridged against the will of the owner of the right.

#### ***2-9(C)(5)(iii) Procedure***

##### ***2-9(C)(5)(iii)(a) Neighborhood Meeting***

At the neighborhood meeting, the applicant shall provide information about the proposed project, including but not limited to the scope of uses, approximate square footages for different uses, general site layout, design guidelines, architectural style, conceptual elevations, and conceptual landscaping plans.

##### ***2-9(C)(5)(iii)(b) Application***

1. An application form and the appropriate fees can be found on the City website as well as the Albuquerque Development and Building Services Center.

2. The submittal shall include:
  - a. A scale drawing showing the location of the easement or right of way to be vacated.
  - b. A cross section of the right of way (if applicable) showing the existing and proposed right of way lines, pavement, curb, gutter, sidewalk, and landscape buffer.
  - c. Letter describing, explaining, and justifying the request per the criteria in IDO Section 14-16-6-6(K)(3) and compliance with the DPM.
3. Submit a completed application form and fee. A public hearing by the DRB will be scheduled within 30 days after the date of acceptance of the application and proper public notification per IDO requirements.

#### **2-9(C)(5)(iii)(c) Development Review Board Public Hearing**

1. The public hearing gives the general public and area resident's opportunity to discuss and speak for or against the request and to elicit additional information which may have a bearing on the request. The applicant or agent must be present at the hearing to speak on behalf of the request and respond to questions.
2. Decision by the DRB may be deferred if additional information or additional public notice seems necessary.
3. The DRB's decision on the request may be to approve, approve with conditions, or deny the request.
4. Right of way and easements over thresholds listed in IDO section 14-16-6-6(K) shall be referred to City Council for approval.
5. The decision is final unless appealed to the LUHO. See IDO for Appeal Procedures.

#### **2-9(C)(5)(iii)(d) Compliance with Conditions**

1. A normal condition of approval requires the Property Management Division to dispose of all public right-of-way declared surplus through the vacation process. Generally all utility and drainage easements are retained unless otherwise specified in the DRB's action.
2. The applicant must prepare and record a plat which incorporates the vacated right-of-way with adjacent property.
3. All conditions must be met within one (1) year from the date of the original decision.
4. The applicant must notify the Development Services Division in writing that all the conditions have been satisfied and upon verification by the Development Services Division, a Certification of Vacation is prepared.

#### **2-9(C)(5)(iii)(e) Certification of Vacation**

1. Vacations are not in effect until a Certificate of Vacation is recorded. The Development Services Division records this Certification of Vacation with the County Clerk and a copy of the certification is sent to the applicant.

# CHAPTER 3

## IMPACT FEES REGULATIONS

This chapter presents the regulations for establishing impact fees for each land development activity in the City of Albuquerque, details of required information in their implementation and administration are covered as follows:

### ARTICLE 3-12 CONTENTS

<b>ARTICLE 3-1 ADMINISTRATIVE ORGANIZATION AND RESPONSIBILITY .....</b>	<b>84</b>
Part. 3-1(A) Impact Fees Administrator .....	84
Part. 3-1(B) Other Departments .....	85
<b>ARTICLE 3-2 IMPOSITION OF IMPACT FEE .....</b>	<b>85</b>
Part. 3-2(A) Fee Payer .....	85
Part. 3-2(B) Determination and Assessment of the Impact Fee.....	86
Section. 3-2(B)(1) General. ....	86
Section. 3-2(B)(2) Assessment of Fee.....	86
Part. 3-2(C) Collection of Impact Fee .....	86
Section. 3-2(C)(1) General.....	86
Section. 3-2(C)(2) Invalid Payment.....	86
Section. 3-2(C)(3) Credits Prior to Completion.....	87
Part. 3-2(D) Expiration of Building Permits .....	87
Part. 3-2(E) Private Security.....	88
Part. 3-2(F) Private Fire Protection or Rescue.....	88
<b>ARTICLE 3-3 DETERMINATION OF AN IMPACT FEE BASED ON FEE SCHEDULES .....</b>	<b>88</b>
Part. 3-3(A) Payment from Schedule .....	88
Part. 3-3(B) Residential Heated Area .....	89
Part. 3-3(C) Gross Floor Area .....	89
Part. 3-3(D) Mixed Use Development.....	89
Part. 3-3(E) Mixed Use Structures .....	89
Part. 3-3(F) Shell Permit.....	89
Part. 3-3(G) Change of Use .....	90
Part. 3-3(H) Accessory or Auxiliary Uses .....	90
Part. 3-3(I) House Moves and Mobile Home Moves .....	91
Part. 3-3(J) Mobile Home/Recreational Vehicles (RVs) Parks .....	91
Part. 3-3(K) Model Homes .....	91
Part. 3-3(L) Remodeling and Redevelopment.....	91
Part. 3-3(M) Miscellaneous Land Use Types .....	91
<b>ARTICLE 3-4 INDEPENDENT FEE DETERMINATION .....</b>	<b>92</b>
Part. 3-4(A) Option of the Fee payer .....	92
Part. 3-4(B) Notice of Intent by Fee payer.....	92
Part. 3-4(C) Pre-Application Meeting .....	92

Part. 3-4(D) Guidelines..... 92  
 Part. 3-4(E) Sufficiency Determination ..... 93  
 Part. 3-4(F) Determination of Impact Fee ..... 94  
 Part. 3-4(G) Effective Date..... 94  
 Part. 3-4(H) Application for Permit..... 94

**ARTICLE 3-5 COLLECTION AND DEPOSIT OF THE IMPACT FEE ..... 95**  
 Part. 3-5(A) Road (Transportation) Impact Fee..... 95  
     Section. 3-5(A)(1) Service Areas ..... 95  
     Section. 3-5(A)(2) Deposit of the Impact Fee..... 95  
 Part. 3-5(B) Drainage (Stormwater) Impact Fees..... 95  
     Section. 3-5(B)(1) Service Areas..... 95  
     Section. 3-5(B)(2) Deposit of the Impact Fee..... 95  
 Part. 3-5(C) Park, Open Space and/or Trails Impact Fees ..... 95  
     Section. 3-5(C)(1) Service Areas..... 95  
     Section. 3-5(C)(2) Deposit of the Impact Fee ..... 96  
 Part. 3-5(D) Fire and Police Impact Fees..... 96  
     Section. 3-5(D)(1) Service Areas ..... 96  
     Section. 3-5(D)(2) Deposit of the Impact Fee..... 96

**ARTICLE 3-6 USE OF IMPACT FEE FUNDS ..... 97**  
 Part. 3-6(A) Purpose..... 97  
 Part. 3-6(B) System Improvements ..... 97

**ARTICLE 3-7 REFUNDS ..... 98**  
 Part. 3-7(A) Refund for Failure to Construct or Provide Service..... 98  
 Part. 3-7(B) Overpayment ..... 98  
 Part. 3-7(C) Underpayment..... 98

**ARTICLE 3-8 EXEMPTIONS..... 99**  
 Part. 3-8(A) Must Be Claimed by Fee Payers ..... 99  
 Part. 3-8(B) Total Exemptions ..... 99  
 Part. 3-8(C) Exemption Based on Error or Misrepresentation ..... 99

**ARTICLE 3-9 CREDITS ..... 100**  
 Part. 3-9(A) General Conditions..... 100  
 Part. 3-9(B) General Documentation and Procedures..... 100  
     Section. 3-9(B)(1) Amount of Credit Requested ..... 101  
     Section. 3-9(B)(2) Documentation..... 101  
     Section. 3-9(B)(3) Submittals for Construction Credits ..... 101  
     Section. 3-9(B)(4) City Approved Work Order ..... 101  
     Section. 3-9(B)(5) Change Orders..... 102  
     Section. 3-9(B)(6) Acceptance of Construction for Credit ..... 102  
     Section. 3-9(B)(7) Acceptance of Land Dedication for Credit ..... 103  
     Section. 3-9(B)(8) Transferability of Credits. .... 103  
     Section. 3-9(B)(9) Withdrawal of Offer by Applicant..... 104  
     Section. 3-9(B)(10) Value of Credits ..... 104  
 Part. 3-9(C) Excess Credits..... 104

**ARTICLE 3-10 EXEMPTIONS ..... 105**  
 Part. 3-10(A) Affordable Housing..... 105  
     Section. 3-10(A)(1) Ownership Housing..... 105  
     Section. 3-10(A)(2) Rental Housing ..... 106

Part. 3-10(B) Development in Metropolitan Redevelopment Areas..... 107

**ARTICLE 3-11 AMENDMENTS..... 107**

The following Administrative Rules and Procedures shall guide the Impact Fees Administrator in the administration of the City of Albuquerque Development Impact Fee Ordinance Enactment No. 0-2012-034 (hereinafter referred to as the Impact Fee Ordinance,) that became effective on December 5, 2012 (effective date). These Administrative Rules elaborate upon the administrative directions contained in the Impact Fee Ordinance and are intended to be used in conjunction with the Impact Fee Ordinance in their implementation and administration.

The fee schedule table in §14-19-13 and applicable service area maps are provided for use in determining the amount of the impact fee for each land development activity. In construing these Rules, all words, phrases and terms contained here shall have the same meaning as defined in the City of Albuquerque Impact Fee Ordinance, in the New Mexico Development Fee Act (§ 5-8-1 et seq., NMSA 1978) and the City of Albuquerque Integrated Development Ordinance (IDO).

## **ARTICLE 3-1 ADMINISTRATIVE ORGANIZATION AND RESPONSIBILITY**

### **Part. 3-1(A) Impact Fees Administrator**

The Impact Fees Administrator is hereby authorized to interpret and enforce all provisions of these Rules and the appropriate Impact Fee Ordinance of the City of Albuquerque and to carry out the general administration of all impact fees enacted by the City of Albuquerque. The Impact Fees Administrator shall have the responsibility to carry out the following:

2. When no equivalent type of land use is present in either the fee schedule or the City of Albuquerque *Integrated Development Ordinance (IDO)*, or is a previously determined miscellaneous land use, the Impact Fees Administrator shall establish a fee applicable to the most nearly equivalent type of land use on the fee schedule.
3. When requested by the fee payer, the Impact Fees Administrator shall assess and certify the impact fee applicable to a particular development using the procedures described in the applicable Impact Fee Ordinance and in these Administrative Rules. The impact fee assessment certification shall be valid for a period of four (4) years.
  - a. *The Impact Fees Administrator, or his/her designee, shall calculate and assess the impact fee as follows:*
    - i *Determine the applicable service area;*
    - ii *Determine the applicable land use type;*
    - iii *Verify the number of units or the amount of gross floor area (whichever is applicable) in the development; and*
    - iv *For the applicable land use type, multiply the unit by the fee per unit from the fee schedule in the Service Area Maps and Impact Fee Schedules.*
  - b. *If the assessment occurs at the time of subdivision plat or site plan approval, the assessment may be estimated based on the applicable fee schedule and be finalized no later than building permit.*



4. With respect to an independent fee determination (see section 5.), the Impact Fees Administrator shall:
  - a. Conduct a pre-application meeting with the applicant and representatives of appropriate departments of the City;
  - b. Review the independent fee determination study for sufficiency, methodology, technical accuracy and findings; and
  - c. Establish the amount of the impact fee as a result of the independent study based on the procedures described in the applicable Impact Fee Ordinance and in these Administrative Rules.
5. The Impact Fees Administrator has sole authority to determine exemptions from a requirement to pay an impact fee or reduction in the amount of the fee.
6. The Impact Fees Administrator shall determine the availability of and the amount of any refund of an impact fee.
7. The Impact Fees Administrator shall calculate the additional impact fee due in the event of change of use, redevelopment, or modifications of an existing use.
8. The Impact Fees Administrator shall calculate and grant credits for contributions, dedications or improvements that may be used to offset any impact fee otherwise due.
9. The Impact Fees Administrator shall maintain separate interest bearing accounts clearly identifying the payer and category of capital improvements within the service area in which the fee was collected.
10. A notice of impact fee assessment for the site shall be included on the final plat.

### **Part. 3-1(B) Other Departments**

Other departments and offices of the City of Albuquerque shall provide advice, information, or other such services upon the request of the Impact Fees Administrator.

## **ARTICLE 3-2 IMPOSITION OF IMPACT FEE**

### **Part. 3-2(A) Fee Payer**

Any person who, after the effective date of the Impact Fee Ordinance, seeks to engage in a new development by applying to the City of Albuquerque for any of the following permits shall be required to pay an impact fee in the manner and amount set forth in the relevant ordinance and in these Administrative Rules:

1. The issuance or extension of a building permit, or certificate of occupancy in the case of a mobile home.
2. The issuance or extension of a permit that would allow the construction or installation of a structure, including a mobile home.

## **Part. 3-2(B) Determination and Assessment of the Impact Fee**

### **Section. 3-2(B)(1) General.**

The amount of the impact fee shall be determined by the Impact Fees Administrator, who shall receive assistance from other departments when necessary and appropriate. The Impact Fees Administrator shall determine whether the method of fee determination is based on the fee schedule contained in the appropriate Impact Fee Ordinance or by an independent fee determination study. The calculation of exemptions, refunds, and credits, and the determination of the net impact fee due shall also be the responsibility of the Impact Fees Administrator with the assistance of appropriate City of Albuquerque Departments.

### **Section. 3-2(B)(2) Assessment of Fee**

The impact fee shall be assessed as follows:

1. For land that is platted or replatted on or after the effective date, the impact fee shall be preliminarily assessed for new development no later than at the time the subdivision plat is recorded;
2. For land platted or replatted prior to the effective date or for development that occurs on existing lots of record, the impact fee shall be assessed at the time of development approval, plan check or issuance of a building permit.
3. The assessment of an impact fee shall be in writing and shall be valid for a period of four years.

## **Part. 3-2(C) Collection of Impact Fee**

### **Section. 3-2(C)(1) General**

The impact fee shall be collected prior to issuance of a building permit. All payments shall be made in the following manner:

1. Payment by approved credit card, personal or business check, cashier's check, or money order payable to City of Albuquerque;
2. All payments are to be made at offices of the City of Albuquerque, Development and Building Services Division of the Planning Department; and
3. In lieu of monetary payment, up to 100% of an impact fee due may be paid by the use of applicable credits as defined in Section 10.

### **Section. 3-2(C)(2) Invalid Payment**

In the event the payment of an impact fee subsequently proves to be invalid due to insufficient funds, improper execution, or for any other reason, then the following actions shall be taken:

1. The Impact Fees Administrator shall, within thirty (30) days of detection of such a deficiency, notify the fee payer, the contractor, and the property owner by certified mail that:
  - a. An impact fee amount is due by valid payment immediately upon receipt of said notice; and

- b. Permits, inspections or certificates of occupancy will not be issued until the amount is paid and, if not paid within thirty (30) days, the Impact Fees Administrator shall have authority to instruct the City of Albuquerque Building Department to stop all construction on the site until the payment is received.*
2. No further building permits, construction permits, inspections or certificate of use and occupancy (C.O.) shall be issued by the City of Albuquerque until the required impact fee is paid; and
3. The amount due shall be the amount of the impact fee plus the amount charged by the bank for the dishonored payment, plus a service charge as established by City of Albuquerque.

### **Section. 3-2(C)(3) Credits Prior to Completion**

In the event the fee payer has received approval from the Impact Fees Administrator for credits for construction of system improvements and the credits are to be applied before completion of the improvements, the following requirements shall be met:

1. The fee payer shall submit the *Irrevocable Letter of Credit* to the Impact Fees Administrator for an amount equal to 125% of the full amount of the completion cost of the system improvements. The letter of credit shall be payable to the City of Albuquerque and shall be approved by the City Attorney prior to acceptance;
2. The fee payer shall procure a City Work Order for the construction of the creditable improvements; which Work Order shall include:
  - a. A performance and warranty bond shall be issued by a company registered in and licensed to do business in the State of New Mexico, for the purpose of securing faithful performance of the construction and to indemnify the City for any damages associated with failure to satisfactorily perform construction, and shall be effective for one (1) year after the City issues a certificate of completion and acceptance;*
  - b. The performance and warranty bond shall be reviewed and approved by the City Attorney prior to acceptance of the bond by the Impact Fees Administrator; and*
  - c. The performance and warranty bond shall be renewed not later than sixty (60) days prior to the renewal date. In the event of a notice to cancel or of intent not to renew, the Impact Fees Administrator shall be entitled to declare a default and make demand on the full amount of the bond.*

### **Part. 3-2(D) Expiration of Building Permits**

1. If a building permit expires, is revoked, or is voluntarily surrendered and is, therefore, voided and no construction or improvement of land has commenced, then the fee payer shall be entitled to a refund, without interest, of 97% of the impact fee which was paid as a condition for its issuance. The City shall retain 3% of the fee for administrative costs. The fee payer must submit an application for such a refund to the Impact Fees Administrator at least thirty (30) days prior to the expiration of the permit. In the case of an expired permit which was obtained in whole or in part by the use of credits, only that portion not paid by credits may be refunded. The fee payer shall apply to the Impact Fees Administrator to reinstate the credits that were not utilized. Any request to reinstate a credit must be made at the time of reapplication or it shall be deemed waived.

2. If a refund has been received by the fee payer, the fee payer must pay the appropriate impact fee if reapplication is made for a permit. If a permit expires and no refund has been issued, a fee payer will not be required to pay the fee again if reapplication is made for the permit on the same lot, parcel or tract unless the use or size of the structure has changed within the previous four (4) years of the original assessment. In the event the use or size of the structure has changed, the amount due would be the change in the amount of the fee based upon the new structure or use.
3. A credit for previous payment of an impact fee must be requested by the fee payer. Any credit not so requested at the time of reapplication shall be deemed waived by the fee payer.
4. A refund of the impact fee shall not be granted if the permit expires and construction has commenced. In this case, the fee payer will not have to pay the impact fee if reapplication is made for a permit for the same type and size of structure.

### **Part. 3-2(E) Private Security**

No credit will be given against a police impact fee for the provision of private security services or facilities.

### **Part. 3-2(F) Private Fire Protection or Rescue**

No credit will be given against a fire impact fee for the provision of private fire protection or rescue services or facilities.

## **ARTICLE 3-3 DETERMINATION OF AN IMPACT FEE BASED ON FEE SCHEDULES**

### **Part. 3-3(A) Payment from Schedule**

The amount of the impact fee shall be determined from the [Service Area Maps and Impact Fee Schedule](#) and as provided by the Impact Fees Administrator or his/her designee, the City of Albuquerque [Impact Fee Summary Form](#).

If the type of land use is not specified in the fee schedule or the Integrated Development Ordinance (IDO), the Impact Fees Administrator shall apply the fee of the most nearly equivalent type of land use on the fee schedule.

The Impact Fees Administrator shall be guided in the selection of a comparable land use type by the City of Albuquerque/Bernalillo County Comprehensive Plan and the land development regulations of the City of Albuquerque, including but not limited to the Integrated Development Ordinance (IDO).

If a fee payer shall opt not to have the impact fee determined according to the fee schedule, then the fee payer shall prepare and submit an independent fee determination study in accordance with the appropriate Impact Fee Ordinance.

In the event that the sub-classification of a particular use of land into the classification established by the Ordinance is unclear, the North American Industry Classification System, United States, latest edition, shall be used as a guide.

### **Part. 3-3(B) Residential Heated Area**

The amount of the impact fee for residential structures shall be based on the floor area of the structure that is designed to be provided with heat and/or air conditioning and not on gross floor area of the structure.

### **Part. 3-3(C) Gross Floor Area**

The amount of the impact fee for non-residential structures shall be based on the total floor area, including basements, mezzanines and upper floors, if any, expressed in square feet and measured from the outside surface of the outside walls, but excluding enclosed vehicle parking areas.

### **Part. 3-3(D) Mixed Use Development**

If a development includes both residential and non-residential uses, the impact fee is to be assessed for each use based on the fee schedule and the results added together. If the owner can substantiate that the impact of the mixed use project justifies a lower impact fee proportionate to the impact reduction, then the Impact Fees Administrator may consider a proportionate reduction of the impact fee. The Impact Fees Administrator is encouraged to utilize the Shared Parking Reduction Section of the Integrated Development Ordinance (IDO), the ULI Shared Parking Standards, and the ITE Manual for guidance.

### **Part. 3-3(E) Mixed Use Structures**

If a structure includes both residential and non-residential uses, the impact fee is to be assessed for each use individually based on the relevant fee schedule and the results added together. If the owner can substantiate that the impact of the mixed use project justifies a lower impact fee proportionate to the impact reduction, then the Impact Fees Administrator may consider a proportionate reduction of the impact fee. The Impact Fees Administrator is encouraged to utilize the Shared Parking Reduction Section of the Integrated Development Ordinance (IDO), the ULI Shared Parking Standards, and the ITE Manual for guidance.

### **Part. 3-3(F) Shell Permit**

Subject to the following qualifications, an impact fee shall not be assessed for tenant development improvements. Builders will often apply for a building permit to construct the "shell" of a building. Remodeling permits would be is-

sued later to finish construction of the interior of the structure. The impact fee shall be paid prior to the issuance of the building permit for construction of the shell. The amount of the fee should be based on the intended land use as described by the builder. If a builder applies for a “shell” permit and the intended land use is not known, the impact fee shall be assessed based on that land use which generates the greatest impact and is allowed under the existing zoning for the lot or parcel. If it is found during review of the application for a Tenant Improvement Permit that the actual land use differs from the intended land use as described in the application, a determination shall be made as to whether or not an additional impact fee is due based on the procedures for change of use. If so, the additional impact fee shall be paid prior to the issuance of the Tenant Improvement Permit. If it is determined that there has been an over-payment of an impact fee, a refund would become available pursuant to the refund provisions of these Administrative Rules.

If a shell permit is deemed complete prior to the effective date, and left unfinished, an impact fee shall not be assessed at the time of reapplication of a shell permit. Subsequent change of use, redevelopment, or modification of the structure may be subject to an impact fee based on the procedures for change of use.

### **Part. 3-3(G) Change of Use**

In the case of a change of use, redevelopment, or modification of an existing use which requires the issuance of a building permit, the impact fee shall be based upon the net increase in the impact fee for the new use as compared to the previous use. The amount of the impact fee that is due as a result of the change in land use shall be determined at the time the fee payer applies for a building permit. The impact fee shall be paid prior to the issuance of a building permit for construction or remodeling.

Previous land use shall be the lawful land use physically existing on the effective date of the ordinance or the current lawful land use. The fee payer shall furnish all documentation required by the Impact Fees Administrator to determine the previous use.

Should the change of use, redevelopment, or modification result in a net decrease in the impact fee, no refunds or credits for the impact fee previously paid shall be made.

If the change of land use does not require the issuance of a building permit, then there shall be no requirement to pay an impact fee.

### **Part. 3-3(H) Accessory or Auxiliary Uses**

Generally, no impact fee shall be assessed for accessory or auxiliary land uses, such as a clubhouse or tennis court in an apartment complex, unless it can be established by the Impact Fees Administrator that the land use constitutes an independent function. However, structures that meet the definition of a “dwelling” in the City of Albuquerque Building Code are not exempted as accessory or auxiliary uses.

### **Part. 3-3(I) House Moves and Mobile Home Moves**

An impact fee shall be assessed for structures or mobile homes moved from one location to another unless the structure or unit being moved is a replacement of an equivalent use at the new location. If the structure or mobile home moved is replaced by an equivalent use at the old location, no impact fee shall be due for the replacement use.

### **Part. 3-3(J) Mobile Home/Recreational Vehicles (RVs) Parks**

Impact fees for a mobile home park or recreational vehicle park shall be collected at the time of building permit, based on the number of mobile home/RV spaces created.

### **Part. 3-3(K) Model Homes**

Model homes on residentially zoned land shall be charged a residential impact fee. Model homes on non-residentially zoned land shall be charged a non-residential impact fee.

### **Part. 3-3(L) Remodeling and Redevelopment**

When a change of use, redevelopment or modification of an existing commercial use or building requires a building permit, the impact fee shall be calculated based on the pro rata difference between previous use and the proposed use.

Remodeling or additions to single family dwelling units shall not be subject to an impact fee.

### **Part. 3-3(M) Miscellaneous Land Use Types**

The Impact Fees Administrator shall maintain a list of the rulings made of any administrative determination.



## **ARTICLE 3-4 INDEPENDENT FEE DETERMINATION**

### **Part. 3-4(A) Option of the Fee payer**

If a fee payer shall opt not to have an impact fee determined according to the [\*Service Area Maps And Impact Fee Schedules\*](#), then the fee payer shall prepare and submit an independent fee determination in accordance with these Administrative Rules and the appropriate impact fee. Any submission not so made at the time of building permit application shall be deemed waived.

The utilization of this option by the fee payer shall not exempt the applicant from paying the impact fee prior to the issuance of a building permit.

### **Part. 3-4(B) Notice of Intent by Fee payer**

The fee payer shall inform the Impact Fees Administrator of the fee payer's intent to utilize an independent fee determination. The Impact Fees Administrator shall then schedule a pre-application meeting with the applicant.

### **Part. 3-4(C) Pre-Application Meeting**

Before beginning the independent fee determination study, the fee payer or the fee payer's representative shall be given the opportunity to attend a pre-application meeting with the Impact Fees Administrator. The purpose of the pre-application meeting is to discuss the procedures of the independent fee determination study, the methodology to be employed, the standards to be met, and to reduce the meeting to a letter of understanding.

Results, conclusions, and agreements reached at the pre-application meeting regarding methodology, required forms or documentation, or procedures, which shall not constitute a waiver of ordinance provisions, shall be placed in a letter of understanding by the Impact Fees Administrator within fifteen (15) days from the pre-application meeting. A copy of this letter of understanding shall be sent to the applicant. The agreements set out in the letter of understanding will expire in thirty (30) days from receipt unless the applicant acknowledges acceptance of the agreements in writing to the Impact Fees Administrator.

The applicant may waive the pre-application meeting. Any applicant who waives a pre-application meeting has waived his/her right to administratively raise methodological or procedural issues at a subsequent time.

### **Part. 3-4(D) Guidelines**

1. The purpose of the independent fee determination study is to measure the impact of the development in question on the roadway facilities, drainage

- facilities, parks, trails and open space facilities, and fire or police facilities of the City of Albuquerque.
2. An independent fee determination study must address the expected impact of the development over the projected life of the structures on the system improvement. Any claim that the use or occupancy of the structures within the development will be different from normal use or occupancy must be supported by the appropriate zone change or other appropriate documentation that will support the claim.
  3. The independent fee determination study shall follow the methodologies and formats which are agreed upon during the pre-application meeting and be in accord with any documentation or methodology required by these Administrative Rules and the appropriate Impact Fee Ordinance.
  4. The independent fee determination study shall be prepared and presented by qualified professionals in good standing in their respective fields. The methodology shall be consistent with best professional practice and support the central claim of the study. The study shall provide all necessary supporting documentation and information. Failure to adhere to best professional standards is a basis for rejection of the study. The applicant's submission must be certified that the study complies with best professional practices.
  5. The applicant shall submit the independent study to the Impact Fees Administrator.
  6. The applicant shall provide the Impact Fees Administrator with the name, address and telephone number of the property owner, the professional preparing the study, and the applicant.

### **Part. 3-4(E) Sufficiency Determination**

1. The Impact Fees Administrator will review the independent fee determination study for sufficiency, methodology, technical accuracy and findings. The Impact Fees Administrator shall have thirty (30) days to review the study and to inform the applicant, in writing, of any deficiencies or defects in the study, or to find the study complete and acceptable. A notice of acceptance or non-acceptance shall be mailed to the applicant. In the event that the notice is not given within thirty (30) days, the study shall be considered complete and acceptable.
2. Upon receipt of a notice of non-acceptance, the applicant may modify or supplement the study and resubmit a modified study. The Impact Fees Administrator will consider the independent fee determination study to be withdrawn and the letter of understanding expired if the Impact Fees Administrator does not receive a response from the applicant within thirty (30) days of receipt of the above notice.
3. Upon receipt of a response or resubmittal of the study, the Impact Fees Administrator shall have thirty (30) days to review the resubmittal or response and notify the applicant of any defects or deficiencies in the submission. If the Impact Fees Administrator finds deficiencies or defects in a resubmitted study, notice of such deficiencies or defects shall be provided as in paragraph 2. above. If the fee payer disagrees with the findings or decisions of the Impact Fees Administrator, the fee payer may appeal the decision as outlined in the applicable ordinance.

### **Part. 3-4(F) Determination of Impact Fee**

The determination of the amount of the applicable impact fee shall be made by the Impact Fees Administrator based on review of a complete and acceptable independent fee determination study.

### **Part. 3-4(G) Effective Date**

The effective date for an impact fee assessed by an independent fee determination study shall be the date at which the Impact Fees Administrator issues a notice of acceptance for the independent fee determination. The independent fee determination shall be valid for four (4) years.

### **Part. 3-4(H) Application for Permit**

It shall be the responsibility of the fee payer, at the time of application for a building permit, to present the approved independently determined fee as approved by the Impact Fees Administrator.

## **ARTICLE 3-5** COLLECTION AND DEPOSIT OF THE IMPACT FEE

### **Part. 3-5(A) Road (Transportation) Impact Fee**

#### **Section. 3-5(A)(1) Service Areas**

There is one (1) City-wide Road (Transportation) Service Area within the incorporated area of the City of Albuquerque, excluding the Mesa del Sol Development.

#### **Section. 3-5(A)(2) Deposit of the Impact Fee**

All road impact fees collected shall be properly identified by the road impact fee service area and promptly transferred for deposit in the appropriate Road Impact Fee Fund to be held in a separate account until expended or encumbered in accord with these Rules and the Impact Fee Ordinance.

### **Part. 3-5(B) Drainage (Stormwater) Impact Fees**

#### **Section. 3-5(B)(1) Service Areas**

There are five (5) Drainage (Storm water) Service Areas within the incorporated area of the City of Albuquerque, excluding the Mesa del Sol Development.

#### **Section. 3-5(B)(2) Deposit of the Impact Fee**

All drainage impact fees collected shall be properly identified by the drainage impact fee service area and promptly transferred for deposit in the appropriate Drainage Impact Fee Fund to be held in a separate account until expended or encumbered in accord with these Rules and the Impact Fee Ordinance.

### **Part. 3-5(C) Park, Open Space and/or Trails Impact Fees**

#### **Section. 3-5(C)(1) Service Areas**

There are four (4) Park Service Areas, one (1) City-wide Open Space Service Area and one (1) City-wide Trails Service Area within the incorporated area of the City of Albuquerque, excluding the Mesa del Sol Development.

**Section. 3-5(C)(2) Deposit of the Impact Fee**

All park, open space and/or trails impact fees collected shall be properly identified by the park, open space or trails impact fee service area and promptly transferred for deposit in the appropriate Park, Open Space or Trails Impact Fee Fund to be held in a separate account until expended or encumbered in accord with these Rules and the Impact Fee Ordinance.

**Part. 3-5(D) Fire and Police Impact Fees**

**Section. 3-5(D)(1) Service Areas**

There is one (1) City-wide Fire Service Area and one (1) Police City-wide Service Area within the incorporated area of the City of Albuquerque, excluding the Mesa del sol Development.

**Section. 3-5(D)(2) Deposit of the Impact Fee**

All fire and/or police impact fees collected shall be properly identified and promptly transferred for deposit in the appropriate Fire or Police Impact Fee Fund to be held in a separate account until expended or encumbered in accord with these Rules and the Impact Fee Ordinance.

## **ARTICLE 3-6 USE OF IMPACT FEE FUNDS**

### **Part. 3-6(A) Purpose**

Funds collected from Road, Drainage, Fire, Police, Parks, Trails and Open Space impact fees shall be used for the purpose of acquiring and/or making system improvements to Road Facilities, Drainage Facilities, Fire Facilities, Police Facilities, Park Facilities, Trail Facilities and Open Space Facilities under the jurisdiction of the City of Albuquerque, the State of New Mexico, or other political subdivisions, and shall not be used for maintenance or operations.

### **Part. 3-6(B) System Improvements**

1. At least once each fiscal year the Impact Fees Administrator shall present to the City Council a report describing the amount of impact fees collected, encumbered and used, and a proposed Component Capital Improvement Program for system improvements, which assigns funds, including any accrued interest, from the Impact Fee Fund accounts to specific system improvement projects and related expenses. Monies, including any accrued interest, not assigned in any fiscal period shall be retained in the same Impact Fee Fund account until the next fiscal period except as provided by the refund provisions of this rule and the Impact Fee Ordinance.
2. Funds shall be used exclusively for acquisitions, expansions, or capital improvements on the City's Component Capital Improvements Plan and within the Impact Fee Service Area from which the funds were collected.
3. In the event that bonds or similar debt instruments are issued for advanced provision of capital facilities for which impact fees may be expended, the impact fee may be used to pay debt service on such bonds or similar debt instruments to the extent that the facilities provided are of the type described in subparagraphs 1. and 2. above.
4. In the event a developer enters into an agreement with the City to construct, fund or contribute system improvements so that the amount of the credit created by such construction, funding or contribution is in excess of the impact fee otherwise due, the developer shall be reimbursed for such excess construction funding or contribution from impact fees paid by other developments located in the service area which is benefitted by such improvements.
5. Only impact fees collected may be used to provide refunds.
6. Funds shall be considered expended on a first in, first out basis by the date received.

## ARTICLE 3-7 REFUNDS

### Part. 3-7(A) Refund for Failure to Construct or Provide Service

1. The current owner of record of property on which an impact fee has been paid shall be entitled to a refund of the fee if the construction of the improvements for which the fee was paid are not completed and available to provide service within seven (7) years from the date of payment of the impact fee.
2. The current owner shall submit a written request for refund to the Impact Fees Administrator within one (1) year of the date giving rise to the right to claim a refund. Failure to make a written request within one (1) year shall constitute a waiver of the right to receive a refund.
  - a. *The current owner shall provide evidence of ownership in the form of a deed or title report;*
  - b. *The Impact Fees Administrator shall make a written decision on the request for refund within thirty (30) days;*
  - c. *If a refund is due to the current owner of record, the City shall issue a refund payment within thirty (30) days of the written decision;*
  - d. *If the Impact Fees Administrator determines that a refund is not due, the current owner of the property may appeal the decision of the Impact Fees Administrator to the City's Environmental Planning Commission within thirty (30) days of the written decision;*
  - e. *The refund shall bear interest calculated from the date of collection of the impact fee to the date of refund as set forth in Section 56-8-3 NMSA, 1978; and*
  - f. *Refunds shall be made on a first in, first out basis by the date received. Prior to making a refund, the Impact Fees Administrator shall notify all eligible fee payers by certified mail of the opportunity to make application for a refund.*

### Part. 3-7(B) Overpayment

A refund, without interest, will be made if it is determined by the Impact Fees Administrator that an overpayment of an impact fee has occurred. Refunds under this section shall not be made more than one (1) year after overpayment of the impact fee has been determined.

### Part. 3-7(C) Underpayment

In the event the Impact Fees Administrator determines that an underpayment of an impact fee has occurred through error or misrepresentation by the fee payer, the Impact Fees Administrator may revoke inspections or withhold the issuance of any building permit or certificate of occupancy, or shall have the power to sue in law or equity as may be provided by law for relief in civil court to enforce the correct payment of the fee.



## ARTICLE 3-8 EXEMPTIONS

### Part. 3-8(A) Must Be Claimed by Fee Payers

An exemption must be claimed by the fee payer no later than 30 days prior to the time of application for a building permit. Any exemption not so claimed shall be deemed waived by the fee payer. Applicants whose requests for exemptions from an impact fee are rejected may appeal the decision within thirty (30) days of the decision as outlined in the applicable Impact Fee Ordinance.

### Part. 3-8(B) Total Exemptions

1. The following shall be exempted from payment of all impact fees:
  - a. *Alteration of an existing building or use of land where the existing use of the property is not changed and there is no additional enclosed or open area in non-residential structures.*
  - b. *The construction of accessory or auxiliary buildings or structures incidental to a dwelling unit on a residential property.*
  - c. *Replacement of a lawfully permitted building, mobile home, recreational vehicle, trailer or structure with a new unit, building or structure of the same type, use and size, will be exempt from the payment of an impact fee. The permit applicant shall document such replacement.*
  - d. *An amendment to a development approval provided that the amended development approval does not increase the number of service units.*
2. In applying for the above-mentioned exemptions, it shall be the applicant's responsibility to furnish, as required by the Impact Fees Administrator, all materials and information necessary to validate the exemption which may include the following:
  - a. *Current survey of the property by a registered professional licensed surveyor;*
  - b. *Old and new construction plans;*
  - c. *Official certificate of occupancy;*
  - d. *Certified statements from owner stating past and proposed land use;*
  - e. *Utility bills or receipts; and*
  - f. *Property tax records.*

### Part. 3-8(C) Exemption Based on Error or Misrepresentation

Exemptions from payment of an impact fee based on error or misrepresentation by the fee payer shall be subject to the provisions found in Section 8.D. of these Rules.

## ARTICLE 3-9 CREDITS

### Part. 3-9(A) General Conditions

An applicant may obtain credit for the value of a system improvement and/or system study to offset up to 100% of an impact fee otherwise due or to become due, by offering to dedicate land, contribute cash, and/or construct improvements for City CCIP projects. Applicants shall file an [Impact Fee Credit Application](#) with the Impact Fees Administrator. Any application for credit must be made and determined prior to the time of application for a building permit or issuance of a work order. Any claim not so made shall be deemed waived. Excess credits shall only be granted for the same category of system improvement and/or system study and within the same service area for which the impact fee was imposed. The authority to determine credit lies exclusively with the Impact Fees Administrator. In every case impact fee credits, shall be calculated so as to be consistent with Section 5-8-15 NMSA, 1978.

1. Credits may be granted subject to the following conditions:
  - a. *Impact fee credits will not be authorized until they are memorialized in a Development Agreement between the City and the Developer for Impact Fee Credits or as further defined in §14-19-19 (A);*
  - b. *Payments made or construction of system or off-site improvements between July 1, 2005 and December 5, 2012 (effective date), provided the system or off-site improvements are on the City's current CCIP;*
  - c. *Payments made or construction of system improvements after December 5, 2012 (effective date), provided the system improvements are on the City's current CCIP;*
  - d. *Credits shall only be granted for the value of the system improvements as listed on the City's current CCIP, including the value of any system studies;*
  - e. *Credits shall be applied first to offset the impact fee otherwise due for the development project for which the credit was granted; and*
  - f. *Upon approval of the impact fee credit application by the Impact Fees Administrator, the Impact Fees Administrator shall issue a [Certificate of Credit](#) to the applicant.*
2. No credit shall be given for:
  - a. *Private improvements;*
  - b. *Road or trail right-of-way dedication after the effective date of the Ordinance.*
  - c. *System improvements and system studies (as defined by the Impact Fee Ordinance) that are not accepted by the City; and*
  - d. *Construction of improvements or conveyance of land for which consideration has previously been given by a governmental body.*

### Part. 3-9(B) General Documentation and Procedures

An offer to make a payment, construct capital improvements or dedicate land in lieu of paying the impact fee shall be made in an application filed with the Impact Fees Administrator identifying the capital improvement and/or land dedication for which credits are requested. If the City of Albuquerque accepts

such an offer, whether the acceptance is before or after the effective date of the Impact Fee Ordinance, the credit shall be determined and provided in the following manner:

### **Section. 3-9(B)(1) Amount of Credit Requested**

The applicant shall specify the dollar amount of the credit requested. The costs claimed by the applicant as the basis for the credit requested shall be no more than the actual costs or the fair market value as determined by the Impact Fees Administrator.

### **Section. 3-9(B)(2) Documentation**

It is the obligation of the applicant to submit written determination, to the satisfaction of the Impact Fees Administrator that supports the amount of the credit requested and indicates the basis on which the amount requested was calculated.

### **Section. 3-9(B)(3) Submittals for Construction Credits**

Prior to site plan, preliminary plat or Work Order approval, the applicant shall enter into a [\*Development Agreement for Credits\*](#) with the City as a condition for the granting of the credits. The Development Agreement for Credits shall establish:

1. The value of the credits;
2. The method by which the credits shall be valued;
3. A requirement that the improvement be completed to applicable City standards;
4. A construction completion deadline for the improvements;
5. Public liability insurance of at least \$1,000,000 per occurrence for which the City is an additional insured; and
6. A labor and material payment bond and a performance and warranty bond in favor of the City.

### **Section. 3-9(B)(4) City Approved Work Order**

An applicant claiming credit for the construction of eligible system improvements and/or land dedication shall procure a City approved Work Order and provide the following information to the Impact Fees Administrator during development review or prior to application for the issuance of building permits:

#### **3-9(B)(4)(i) Construction of System Improvements**

The credit applicant shall submit a project description in sufficient detail with an engineer's cost estimate prepared by a professional engineer, to allow the Impact Fees Administrator to verify the cost estimates. The engineer's estimate shall include:

1. Construction costs including NM gross receipts tax;
2. Design costs;
3. Land acquisition costs;
4. Testing, survey and inspection costs; and

5. In no case shall the cost for design, engineering, testing, surveying, inspections, and overhead constitute more than 17% of the construction credit granted.

### **3-9(B)(4)(ii) Land Dedication**

A credit applicant requesting credit for land dedication for approved improvements, shall present the following, as applicable and as determined by the Impact Fee Administrator:

1. An approved subdivision plat;
2. A warranty deed to convey title to the appropriate governmental body;
3. A title policy issued by a title insurance company in good standing and authorized to do business in New Mexico;
4. A certified copy of the most recent assessment of the property for tax purposes;
5. A certified statement from the county treasurer certifying that all property taxes are current and paid;
6. A property appraisal prepared by qualified professionals approved by the City. In preparing their reports, appraisers shall value the land prior to any increase in value resulting from the development approval; and
7. Confirmation that the land to be dedicated is included in the City's current CCIP.
8. Phase I Environmental Study.
9. Other documentation as determined by the Impact Fee Administrator, e.g. geotechnical report, ALTA survey, etc.

### **Section. 3-9(B)(5) Change Orders**

No increase in the amount of approved credit will be authorized unless it is determined during actual construction of the agreed-to improvements that change orders are to be made incurring additional expense for items that are necessary and are not shown on the approved plans and estimates previously furnished to the Impact Fees Administrator. It shall be the fee payer's responsibility to obtain prior approval from the Impact Fees Administrator before all such change orders are made. All requests for an increase of the approved credit shall include all documentation required by the Impact Fees Administrator.

### **Section. 3-9(B)(6) Acceptance of Construction for Credit**

Credit against the impact fee otherwise due will not be provided until:

1. The construction is completed and accepted by the City as shown by a certificate of completion and acceptance signed by the City Engineer;
2. As-built record drawings are submitted to the City and certified by a New Mexico registered engineer;
3. A suitable performance, maintenance or warranty bond or irrevocable letter of credit is submitted to and approved by the City Attorney; or
4. In the case of 6.f. below, upon completion of the agreed-to construction improvements and upon acceptance by the appropriate governmental authority pursuant to 6.a. above, the bond may be reduced to an amount and a time period as provided for by the City to cover a maintenance period for the improvements;

5. All design, construction, inspection, testing, bonding and acceptance procedures are in strict compliance with the then-current City ordinances and policies, as they may be applicable; and
6. Credit may be provided before completion of specified improvements if the fee payer posts a financial guaranty for the costs of such construction in the form of an irrevocable letter of credit to be posted with the City in an amount determined by the Impact Fees Administrator equal to 125% of the full cost of construction. In the event of cancellation of the financial guaranty, notice of intent to cancel or not to renew must be given to the Impact Fees Administrator no later than sixty (60) days prior to the renewal date. In such event of a notice to cancel or of intent not to renew, the Impact Fees Administrator shall be entitled to declare a default and collect the full amount of the financial guaranty. The financial guaranty shall be outlined in the *Irrevocable Letter of Credit*.
  - a. *If the construction project will not be completed within two (2) years of the execution date of the Development Agreement for Impact Fee Credits, the amount of the financial guaranty shall be increased by 10% compounded for each year of the life of the financial guaranty. The financial guaranty shall be reviewed and approved by the City Attorney prior to acceptance of the financial guaranty by the City.*
  - b. *In the event that: (1) the City receives notification from the guarantor that the financial guaranty is being canceled before all agreed-to improvements have been completed and accepted by the appropriate governmental body; or (2) the City determines that terms of the agreement for construction as set forth in the financial guaranty are not being complied with, then the City shall, in accordance with the terms of the financial guaranty, make demand on the financial guaranty and collect the full amount of the financial guaranty to be used for completion of the agreed-to improvements and other expenses. If the cost incurred by the City to complete the improvements exceeds the amount received from the financial guaranty, the City shall have the right to sue in law or equity to recover the difference.*

### **Section. 3-9(B)(7) Acceptance of Land Dedication for Credit**

Credits for land dedication shall be granted when the following procedures have been completed and title to land has been delivered and accepted by the appropriate governmental body and recorded in the Bernalillo County Clerk's Office.

1. The delivery to the Impact Fees Administrator of a deed, with sufficient funds to pay all costs of transfer of title, including the recording of a plat if required;
2. The escrow or payment of taxes prorated to the date of closing; and
3. The issuance of a title insurance policy subsequent to recording of the deed and escrow of taxes.

### **Section. 3-9(B)(8) Transferability of Credits.**

Impact fee credits may be transferable from one project or development to another if provided for in the Development Agreement for Impact Fee Credits with the City of Albuquerque.

### **Section. 3-9(B)(9) Withdrawal of Offer by Applicant**

Any person who offers land and/or improvements in exchange for credits may withdraw the offer of dedication at any time prior to the execution of the Development Agreement and pay the full impact fee required by the appropriate Impact Fee Ordinance.

### **Section. 3-9(B)(10) Value of Credits**

The value of credits granted for approved construction will be established by the Impact Fees Administrator and will be based on actual construction costs as defined and approved in the City's Work Order Close-Out Process. Should the developer request credits in advance of the actual construction of the improvements and post a financial guarantee to secure 125% of the estimated value of the credits, the Impact Fees Administrator will review the actual construction costs to ensure the value of the work meets or exceeds credits granted. The Agreement and Financial Guarantee will be released once the work has been accepted by the City and the value of credits has been confirmed by the Impact Fees Administrator. Should the value of the work established through the City's Work Order Close-Out Process exceed the value of the estimated credits granted, the developer may request an increase in credits granted for a project from the Impact Fees Administrator.

Should the value of the work established through the City's Work Order Close-Out Process be less than the value of the estimated credits granted, the Impact Fees Administrator shall, at his option, be able to directly draw from the financial guarantee for the difference in those amounts.

## **Part. 3-9(C) Excess Credits**

1. If the value of the credits exceeds the amount of impact fee otherwise due, the applicant shall be entitled to excess credits and the Impact Fees Administrator shall issue a *Certificate of Excess Credits*. The Certificate of Excess Credits shall state:
  - a. Dollar amount of the excess credits;
  - b. The system improvement category;
  - c. Service area to which the excess credits may be applied;
  - d. Name of the applicant as the original credit holder;
  - e. Description of the Component Capital Improvement Plan Project for which the excess credits were granted; and
  - f. The year(s) in which the excess credits may be applied.
    - i. The Certificate of Excess Credits shall be dated, executed and notarized by the Impact Fees Administrator and the applicant.
2. Excess credits shall only be applied for the same category of system improvements and/or system studies and within the same service area for which the impact fee was imposed.
3. Excess credit and credits shall be freely assignable provided notice to Impact Fees Administrator is provided prior to the assignment, in the *Notice of Assignment of Credits* form.
4. Excess credits shall not accrue interest.
5. The Impact Fees Administrator shall upon request of the excess credit-holder reimburse excess credits on a first in, first out basis. The applicant submits a *Request for Reimbursement of Excess Credits* form to the Impact Fee Administrator. The Impact Fees Administrator shall not be obligated to

provide reimbursement in the event there is no unencumbered account balance in the City's impact fee account for the applicable service category and service area.

6. Excess credits must be used, sold or redeemed within fifteen (15) years after their issuance. Excess credits issued prior to the effective date of the Ordinance shall be permitted to be used, sold or redeemed within fifteen (15) years after the effective date of the Ordinance. Excess credits not used, sold or redeemed within fifteen (15) years of the effective date shall expire.

## ARTICLE 3-10 EXEMPTIONS

### Part. 3-10(A) Affordable Housing

#### Section. 3-10(A)(1) Ownership Housing

1. **Affordable:** On the first working day of each fiscal year, the Department of Family and Community Services, or its successor department, shall issue a determination of housing affordability based on the purchase price of a home. An affordable purchase price will be defined as what is affordable for a hypothetical household of four persons at 80% of Median Family Income (MFI), adjusted for family size as determined by the U.S. Department of Housing and Urban Development, if that household spends 30% of household income on housing costs and assumes a conventional mortgage at the Freddie Mac 30 year mortgage annual percentage rate published in the week prior to July 1.
2. Impact fees shall be waived fully or partially on building permits for new housing units that meet the definition of affordability as defined above.
3. In mixed income projects, 60% of the impact fees will be waived for affordable units that are located outside of the areas where impact fees are waived completely. In determining whether a development qualifies as a mixed-income project under R-04-159, the percentage of units that meet the definition of affordable, after the fee waiver, is at least 20% and not more than 50% of the total number of units in the development and also where at least 50% of the units have a sales price that is above the determination of housing affordability.
4. Finalization of impact fee waivers for affordable housing will be contingent upon an approved certification by the City of Albuquerque that documents the unit was purchased by an income qualified buyer at a price that does not exceed the determination of housing affordability and before closing can provide documentation that the loan is structured in such a way that the buyer is not making monthly payments greater than of their household income. Documentation of purchaser income will be completed by the mortgage lender on forms provided by the City and approved by the Department of Family and Community Services.
5. A deed restriction, or another mechanism for the amount of the waived impact fee, will be placed on the property when the developer can provide an executed purchase agreement for a house price that falls within what has been defined as affordable. Before closing on the property, the mortgage lender will provide documentation to the Department of Family and Community Services that the buyer is at or below 80% of MFI and is not paying more than 30% of their household income on the first mort-



gage. Once the City has reviewed and approved this documentation, the deed restriction or other mechanism will be released five years (5) after the closing date. If the buyer cannot be shown to meet the income guidelines defining affordability, the developer will be responsible for paying the impact fees to the City in order to release the deed restriction or other mechanism.

**Section. 3-10(A)(2) Rental Housing**

1. **Affordable:** On the first working day of each fiscal year, the Department of Family and Community Services or its successor department shall issue a determination of affordability for rental housing calculated on the monthly rental costs for a housing unit occupied by a household at 60% and 80% of MFI adjusted for family size, as determined by the U.S. Department of Housing and Urban Development, paying 30% of monthly income on housing costs. In making this calculation, household size shall be converted to number of bedrooms per rental unit as follows:

<b>Household Size</b>	<b>Bedrooms</b>
1 & 2 Persons	1
3 Persons	2
4 Persons	3
5 Persons	4

2. Impact fees will be waived for rental housing only for those projects developed under an agreement with an agent of local, state, or federal government which requires that a specified number of units be available at affordable rents only to households at or below 60% of MFI for a period of no less than fifteen (15) years. The agreement must specify the income test used to identify renters that qualify for affordable units.
3. Impact fees for mixed income projects in adopted centers and corridors shall be waived completely proportionate to the percentage of units affordable to households at or below 60% of MFI adjusted for household size. For mixed income projects not located in adopted centers and corridors, 60% of impact fees will be waived proportionate to the percentage of units affordable to households at or below 60% of MFI adjusted for household size. To qualify for a waiver of impact fees for a mixed income project, the affordable units (at 60% MFI) must be at least 20% and not more than 40% of all units in the project. In addition, the agreement must specify that at least 30% of the units will be at rents at or above the determination of affordability for households at 80% MFI adjusted for family size.
4. For rental projects that are not part of a mixed-income project, as defined in R-040-159, impact fees will be waived in proportion to the percentage of affordable units that will be reserved for households at or below 30% of MFI adjusted for family size.

## **Part. 3-10(B) Development in Metropolitan Redevelopment Areas**

Full or partial waivers of impact fees shall be provided for nonresidential and residential development within Metropolitan Redevelopment Areas (MRA) that conform to the MRA and applicable MR Plan.

### **ARTICLE 3-11 AMENDMENTS**

All additions or changes to these Administrative Rules shall be subject to review and approval pursuant to the Development Process Manual process as agenda items during the regular meetings of the Development Process Manual Executive Committee. *Copies of these Administrative Rules* as revised and approved by the Mayor shall be made available to all City Staff who administer impact fees and shall be made available to members of the general public, upon request, at designated locations in the City of Albuquerque.

# CHAPTER 4

## CONSTRUCTION PLAN STANDARDS

This chapter presents the standards established for drafting and infrastructure construction plans to be submitted for approval to the City of Albuquerque. Detailed requirements for drafting, original drawing material, organization of plans, details of required information and acceptable methods of presentation are covered as follows:

### ARTICLE 4-7 CONTENTS

<b>ARTICLE 4-1 GENERAL PLAN INFORMATION.....</b>	<b>111</b>
Part. 4-1(A) General Plan Information.....	111
Part. 4-1(B) CAD Software.....	111
Part. 4-1(C) Plan Submittals .....	111
Section. 4-1(C)(1) Project Development Stage (30%, 60%, 95%, 100%) .....	111
Section. 4-1(C)(2) Final Plan Submittal (For City of Albuquerque Projects).....	112
Section. 4-1(C)(3) Plan Revisions.....	112
<b>ARTICLE 4-2 PLAN SHEET ORGANIZATION.....</b>	<b>113</b>
Part. 4-2(A) File Accuracy (units).....	113
Part. 4-2(B) Sheet Sizes.....	113
Part. 4-2(C) Sheet Borders .....	113
Part. 4-2(D) Plan Sheet Assembly.....	113
Part. 4-2(E) Construction Document Arrangement.....	113
<b>ARTICLE 4-3 GRAPHIC STANDARDS .....</b>	<b>114</b>
Part. 4-3(A) Plan Scales .....	114
Part. 4-3(B) Line Weights .....	114
Part. 4-3(C) Line Types/Styles.....	115
Part. 4-3(D) Screening .....	115
Part. 4-3(E) Text Styles and Fonts .....	115
Part. 4-3(F) General Text Placement .....	115
Part. 4-3(G) Drawing Callouts.....	116
Part. 4-3(H) Keyed Notes .....	116
Part. 4-3(I) Bar Scales .....	116
Part. 4-3(J) Dimensioning.....	116
Part. 4-3(K) Legend.....	116
Part. 4-3(L) North Arrow .....	116
<b>ARTICLE 4-4 DRAFTING PRACTICES .....</b>	<b>117</b>
Part. 4-4(A) Drawing Layout.....	117
Section. 4-4(A)(1) Title Blocks.....	117
Section. 4-4(A)(2) View Orientation .....	117
Part. 4-4(B) Required Notation and Topography.....	118
Section. 4-4(B)(1) Coordinate Systems .....	118
Section. 4-4(B)(2) Directional Indicators.....	118

Section. 4-4(B)(3) Benchmarks .....118  
 Section. 4-4(B)(4) Symbols.....119  
 Section. 4-4(B)(5) Right-of-Way.....119  
 Section. 4-4(B)(6) Utilities.....119  
 Section. 4-4(B)(7) Existing Features.....119  
 Part. 4-4(C) Cross Referencing Between Drawings ..... 121  
 Section. 4-4(C)(1) Section and Detail References .....121  
 Section. 4-4(C)(2) Project Phasing, Bid Lots, or Bid Alternatives (For City Projects Only).....121

**ARTICLE 4-5 PLAN SHEET CONTENT ..... 122**

Part. 4-5(A) Title or Cover Sheet..... 122  
 Part. 4-5(B) Index of Sheets/Key Map..... 123  
 Section. 4-5(B)(1) Index of Sheets.....123  
 Section. 4-5(B)(2) Key Map .....123  
 Part. 4-5(C) General Notes/Legend Sheet..... 123  
 Section. 4-5(C)(1) General Notes.....123  
 Section. 4-5(C)(2) Legend .....124  
 Part. 4-5(D) Summary of Quantities Sheet (Applicable to City of Albuquerque Projects Only) ..... 124  
 Part. 4-5(E) Survey Control Sheet..... 124  
 Part. 4-5(F) Horizontal Layout Sheet..... 124  
 Part. 4-5(G) Removals Sheet ..... 125  
 Part. 4-5(H) Plat Sheet..... 125  
 Part. 4-5(I) Approved Grading and Drainage Plan ..... 125  
 Part. 4-5(J) Erosion Control Plan..... 126  
 Part. 4-5(K) Master Street Plan..... 126  
 Part. 4-5(L) Typical Sections Sheet..... 126  
 Part. 4-5(M) Environmental Sheet ..... 127  
 Part. 4-5(N) Roadway Plans ..... 127  
 Section. 4-5(N)(1) Stationing .....127  
 Section. 4-5(N)(2) Horizontal Curve and Line Data for Left and Right Curb ...127  
 Section. 4-5(N)(3) Right-of-Way.....128  
 Section. 4-5(N)(4) Sheet References .....128  
 Section. 4-5(N)(5) Profiles and Grades.....128  
 Section. 4-5(N)(6) Driveway Information/Details .....129  
 Part. 4-5(O) Geometric Details/Special Details ..... 130  
 Section. 4-5(O)(1) Geometric Details.....130  
 Section. 4-5(O)(2) Specific Details .....130  
 Part. 4-5(P) Construction Traffic Control Details (Applicable to City of Albuquerque Projects)..... 130  
 Part. 4-5(Q) Signing and Striping Details/Layout Sheets ..... 131  
 Section. 4-5(Q)(1) General .....131  
 Section. 4-5(Q)(2) Signage .....132  
 Section. 4-5(Q)(3) Striping.....132  
 Section. 4-5(Q)(4) Plan Symbol Coding.....132  
 Part. 4-5(R) Traffic Signalization Details/Design Sheets ..... 133  
 Section. 4-5(R)(1) Traffic Signal General Notes & Legend.....133  
 Section. 4-5(R)(2) Equipment & Incidental items, Interconnect Requirements..133  
 Section. 4-5(R)(3) Traffic Signal Estimated Quantities .....133  
 Section. 4-5(R)(4) Traffic Signal Plan.....134  
 Section. 4-5(R)(5) Street "A" & Street "B" Traffic Signal Cables & Conduits- I...134  
 Section. 4-5(R)(6) Street "A" & Street "B" Traffic Signal Cables & Conduits- II..134

Section. 4-5(R)(7) Traffic Signal Blocks.....134  
Part. 4-5(S) Lighting Details/Design Sheets..... 134  
Part. 4-5(T) Roadway Cross Sections ..... 135  
Part. 4-5(U) Drainage Details ..... 135  
Section. 4-5(U)(1) Utilities .....135  
Section. 4-5(U)(2) Right-of-Way.....136  
Section. 4-5(U)(3) Sheet References.....136  
Section. 4-5(U)(4) Storm Drainage and Profile Drawings .....136  
Section. 4-5(U)(5) Catch Basins and Connector Pipe Information.....137  
Section. 4-5(U)(6) Utility Crossings .....137  
Section. 4-5(U)(7) Stand Alone Drainage Plans.....137  
Section. 4-5(U)(8) Channel Plans.....137  
Section. 4-5(U)(9) Channel Cross Sections .....138  
Part. 4-5(V) Utility Sheets ..... 139  
Section. 4-5(V)(1) Master Utility Plan (Water, Sewer and Storm Drain).....139  
Section. 4-5(V)(2) Water Lines.....139  
Section. 4-5(V)(3) Sanitary Sewer .....141

**ARTICLE 4-6 RECORD DRAWING CRITERIA ..... 143**

Part. 4-6(A) General Criteria ..... 143  
Part. 4-6(B) Digital Record Criteria..... 144

## ARTICLE 4-1 GENERAL PLAN INFORMATION

### Part. 4-1(A) General Plan Information

All final plan sheets shall be sealed and signed by an appropriate New Mexico licensed professional ( e.g. Engineer, Civil, Structural, Electrical, Architect, Landscape Architect etc.), and be provided on 22 inch x 34 inch (ANSI D) reproducible bond sheets. Half size plans (11 inch x 17 inch) shall be true half scale.

Special non-standard details shall be prepared and shown to scale on separate detail sheets as needed per discipline, with appropriate construction notes and quantities as needed.

Removal and installation notes shall be numerically referenced and listed on the right-hand side of each sheet. Notes shall be consistent with the most recent COA CAD standards. All quantities shall be summarized on a separate quantity summary sheet. Work to be done by others shall be called out simply with arrows and labeled "BY OTHERS".

Plans shall generally be prepared in accordance with the latest City of Albuquerque Standard Specifications and Details unless otherwise directed by the City Engineer. As bridge structures are not specifically covered in the City's Standard Specifications and Details, they shall generally be covered by [NMDOT Standard Specifications and Details](#), current edition.

All sample plan types, borders, and symbology shall be obtained from the [City of Albuquerque's website](#).

### Part. 4-1(B) CAD Software

The City of Albuquerque requires that all drawing files be in either Auto CAD 2010 compatible drawing format or Civil 3D. Any field software used in data collection must be fully compatible with one of these Auto CAD formats.

### Part. 4-1(C) Plan Submittals

#### Section. 4-1(C)(1) Project Development Stage (30%, 60%, 95%, 100%)

For City projects, required plan submittals will be outlined at the Project Scoping Meeting. Each plan submittal will include, at a minimum, the following:

1. Construction cost estimate with the appropriate amount of contingency applied based on the submittal being made. (For private development projects, an estimate is only required at 100% submittal).
2. Appropriate number of bound copies of full size and half size plans as requested by DRC for review.

3. Previous redline review plans and any comment summary sheets supplied to the Applicant by the DRC.
4. One CD containing complete current version of scalable .pdf files of the design plans at each plan submittal stage. The .pdf shall contain all plan sheets available for that submittal (i.e. 30%, 60%, 95%, 100%) and an index.

Drawings submitted which do not meet the current City of Albuquerque CAD Standards may be returned for correction and re-submittal. Submittals NOT accompanied by previous City redline reviews will not be accepted. All submittals shall be Quality Assurance/Quality Control checked before each submittal. Submittals that do not address redlines or comments made by the City at a previous submittal, or are below the expected standard of the percentage submittal will be returned without City/DRC review.

The [\*Milestone Submittal Checklist\*](#) can be found on the City of Albuquerque's website (30%, 60%, 95%, 100%, and Final). These checklists only serve as a guideline for expectations and requirements at each design stage.

### **Section. 4-1(C)(2) Final Plan Submittal (For City of Albuquerque Projects)**

Once the appropriate signatures have been obtained on the plans, an electronic digital copy (.pdf) of the Construction drawings shall be provided to the Municipal Development Department, Construction Services Division, and the Maps and Records Section of the Water Authority before construction begins.

### **Section. 4-1(C)(3) Plan Revisions**

Revisions to plans will be made in the "Revisions Block" only after DRC approval and signature by the City Engineer. Any plan changes made prior to DRC general approval signatures are not required to appear in the "Revision Block".

All revisions after the plans are signed for approval by the DRC shall be identified by a triangle with the revision number and the name or initials of the person making the revisions. The triangle, along with the revision number shall be shown in the plan and/or profile view of the sheet along with a revision cloud surrounding the required plan change. The number and date of the revision shall then be recorded in the "Revisions" portion of the sheet border. The title sheet shall list only the sheets on which revisions have been made.

A Revision Block is necessary on the Cover Sheet of all revised plans and must note "Sheet No. \_\_ revised" with the date and must include sheets added, deleted, or sheet numbers changed. A space must also be provided on the Cover Sheet for the City Engineer's approval of all plan revisions. Substantive revisions may require additional signatures as determined by the City Engineer.

Any party who makes revisions must ensure that the contractor, the owner, the Inspection Section (for City projects), and DRC (for private development projects) receive revisions as soon as possible so that construction changes can be noted.

All written corrections on the plan shall be legible in a permanent manner.



## **ARTICLE 4-2 PLAN SHEET ORGANIZATION**

### **Part. 4-2(A) File Accuracy (units)**

Engineering working units shall be as follows:

- i. Master Units = Survey Feet (ft)
- ii. Sub Units = Survey Inches (in) or Decimal Feet (x.xx)

Architectural working units shall be as follows:

- i. Master Units = Feet (ft)
- ii. Sub Units = Inches (in) or Decimal Feet (x.xx.)

### **Part. 4-2(B) Sheet Sizes**

ANSI D size (22" x 34") borders shall be used for all drawings. All drawings shall be set-up to be plotted true half-scale on 11x17/tabloid. Use of non-standard sheets must have prior approval of the City Engineer or City Architect in writing.

### **Part. 4-2(C) Sheet Borders**

The plans shall utilize the approved City of Albuquerque sheet borders for the preparation of the cover sheet, plan and profile sheets, and detail sheets. These files shall be obtained from the [City of Albuquerque's website](#) or the City Project Manager.

### **Part. 4-2(D) Plan Sheet Assembly**

There shall be one sheet file per drawing. Designs (sometimes called "Base files", created in model space) intended to be referenced into sheet drawings, should be kept as separate files. There shall be one title block/border model file per project.

### **Part. 4-2(E) Construction Document Arrangement**

The drawings within the Construction Documents set shall be arranged in the following sequence as shown in the [Milestone Submittal Checklist](#) (for City projects) or the [DRC Checklist](#) (for private development projects).

Drawings within each discipline shall be arranged in sequence following lead discipline. i.e., if a new roadway design is to have utilities installed underneath, the utilities portion of the plan set should follow the same or similar geographical direction and scale as the roadway Plan & Profiles.

## ARTICLE 4-3 GRAPHIC STANDARDS

Unless otherwise specified, the graphic standards shall be as recommended in the COA CAD Standards. The line widths and color requirements for specific features should be followed as outlined in the City of Albuquerque CAD Standards. The following information can also be obtained from the [City of Albuquerque's website](#).

### Part. 4-3(A) Plan Scales

The scales for the various plan sheets can be found in [Article 4-5 PLAN SHEET CONTENT](#), and should be followed unless otherwise approved by the City's Project Manager or City Engineer.

In special circumstances, on a project by project basis, any combination of the following scales may be used with prior approval by the City Project Manager or City Engineer:

Horizontal	Vertical
1"=100' *	1"=10'
1"=50'	1"=5'
1"=40'	1"=4'
1"=20'	1"=2'
1"=10'	1"=1'

### Part. 4-3(B) Line Weights

Line weights must conform to the City of Albuquerque standards shown in the color based pen Line Weight Template, see the file called [COA LineWeights.dwg](#). Line weights and screening are based on color. Plans containing line work which does not reproduce satisfactorily will not be accepted by the Design Review Committee (DRC).

The actual display color associated with a specific AutoCAD element color is defined by the color table, CAD versions of the table can be accessed at the [City of Albuquerque's Website](#). If the user is unable to distinguish between the assigned colors, the screen color table can be modified. However, the line widths used shall be as recommended in these CAD Standards.

Proposed features should be displayed using a line weight of not less than 0.01 but not more than 0.025. Line weight and screening definitions by color are listed, as well as, a visual representation of what each color in the table looks like when displayed.

<sup>1</sup> Horizontal and vertical scale combinations shall not result in an exaggeration greater than 10:1. \*Scales of 1"=100 can be utilized for overall layouts only.

### **Part. 4-3(C) Line Types/Styles**

Only the default, “out-of-the-box” AutoCAD line styles, or the COA CAD Standard supported/furnished line styles shown in the Line Types Template shall be used, see the file called [COA\\_LineTypes.dwg](#). All line types must conform to the standards shown in the template.

Custom line styles developed by the user are not desired. In the event a custom line type/style is needed, approval by the City is needed.

### **Part. 4-3(D) Screening**

Screened colors (half-tone lines) shall be used to depict existing/unchanged features on plan, profiles and sections. Grids on profiles & sections may be screened.

### **Part. 4-3(E) Text Styles and Fonts**

The TrueType (TT) font Arial shall be used for text callouts and dimensions. If symbols such as “+” or “=” are a part of the text, TT Symbols shall be used. TT Lucida Console shall be used for general notes and table/schedule text. All text shall be in upper case unless lower case lettering is needed to define a formula. TT Arial Black shall be used for a filled font.

The file called [COA\\_Text\\_Dim\\_Style.dwg](#) contains the COA standard Dimension style and text styles. Text style applications are defined in the template, lettering must generally conform to these standards.

### **Part. 4-3(F) General Text Placement**

Text shall be placed using text nodes when more than one line of text is placed. Text node justification shall be set so that moving the node will not be required or will be minimal should the text require future editing. For example, general numbered notes shall have upper left justification, elevation labels appearing to the left of a feature shall have bottom right justification, and elevation labels appearing to the right of a feature shall have bottom left justification. Text shall never be placed over other text. Text shall not obscure feature lines, hatching, or patterning. If text is placed in a hatched or patterned area, the hatching/patterning shall be clipped so the text can be clearly read.

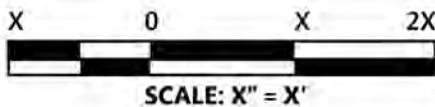
## Part. 4-3(G) Drawing Callouts

Callouts shall be left justified, and whenever possible, they shall be aligned. Callout text shall be placed so that it appears horizontal on the sheet file. Callout leaders shall never cross text, dimension lines, or each other. Placing callout leaders through dimension extension lines shall be avoided whenever possible; however, if this type of placement is necessary, the extension line shall be broken where the leader line passes through it. This shall be accomplished without exploding the dimension. When placing callouts, long lines shall be avoided so each callout remains within the modular area of the detail. If the leader to the multi-line callout is on the right side, the lines of text subsequent to the first line of text should be no longer than the first line of text whenever possible.

## Part. 4-3(H) Keyed Notes

Keyed notes shall be placed on the right hand side of the drawing. Only those notes shown on any one particular sheet should be listed. Key note numbers shall remain the same for each note throughout the drawing set; a master key note list can be referenced near the beginning of each plan type, if desired.

## Part. 4-3(I) Bar Scales



Sheet files shall contain the appropriate bar scale(s). The Graph bar scale shown in Bar Scale Template, is an example of what should be used. The file called [COA\\_BarScale.dwg](#) contains the COA standard scale.

## Part. 4-3(J) Dimensioning

The automatic dimensioning features of AutoCAD shall be used for all dimensioning. Association shall be toggled on. If the extension line is broken to accommodate the placement of a callout leader, the association shall be dropped. Filled arrowheads shall be used as dimension terminators.

## Part. 4-3(K) Legend

Provide a legend identifying the nature of lines and symbols used in drawing the plans. The Legend Template provides acceptable standard symbols. The file, [COA\\_Legend.dwg](#), contains a basic sample legend and can be obtained from the [City of Albuquerque's website](#).



## Part. 4-3(L) North Arrow

The location of the north arrow shall be consistent (or as consistent as possible) within the drawing set, typically located in the upper right hand corner of the drawing or detail. The electronic file of the north arrow can be obtained from the [City of Albuquerque's website](#).

## ARTICLE 4-4 DRAFTING PRACTICES

In general, all features shall be drawn to scale. Prefabricated items for which exact dimensions may vary depending on the manufacturer shall be drawn proportional. Connecting feature/component lines shall connect. When break or match lines are used, feature lines shall be terminated at the break or match line. Match lines connecting two sheets shall match exactly.

All line work within the sheet shall be trimmed back so as not to encroach on the line work for the border.

### Part. 4-4(A) Drawing Layout

#### Section. 4-4(A)(1) Title Blocks

All plan sheets, except for the Cover Sheet, shall have a title block in the lower right-hand corner of the sheet (see [Title Block Template](#) for sample sheet). This title block, included in the City's Auto CAD Standard sheets, shall have the following information clearly displayed:

1. Name of Organization preparing the plans.
2. The contracting Division shall be indicated under the "City of Albuquerque Municipal Development Department " within the title block (City of Albuquerque Projects only).
3. The type of plan depicted on each sheet (for example, "PAVING" or "STORM DRAIN").
4. The Project Description (e.g. Southern Blvd: Eubank Blvd to Juan Tabo Blvd). Project street name descriptions shall generally be labeled from south to north or from west to east. The plan shall normally use the same project description provided in the contract.
5. The City Project Number (e.g. 738001).
6. The individual sheet number.

#### Section. 4-4(A)(2) View Orientation

Drawings views shall generally be oriented so that north points to the top of the sheet or to the right. Street centerline stationing should normally increase from left to right on the sheet. Utilities constructed within and generally parallel to the street right-of-way shall be stationed relative to the street centerline with stations and offsets. The drawing shall include ties to intersecting street centerlines or existing documented property corners or city monuments so that all construction baselines can be easily reestablished, and so that the project can be staked directly from the plans without ambiguity.

Views shall be orientated on the sheet so that plan and profile views are aligned whenever possible. When detailing, details shall appear on the sheet based on their orientation on the feature. For instance, a detail of the top of a wall shall be orientated above a detail of the bottom of the wall. If a detail is taken from a large-scale plan or elevation, the orientation shall remain the same as the view from which the cut was taken. If this is not possible, a note stating the orientation was changed will be added (e.g., VIEW ROTATED 90 DEGREES). When two or more plans of the same structure or the plans of two or more different structures are put on the same drawing, the orientation of all must conform to one another and to their relative positions on the ground.

Orient enlargements, insets, or other detail plan in the same direction as the plan from which it was taken. If impractical to do so, include a north arrow for each enlargement, inset, or detail plan.

Maintain one (1) direction of profile stationing on all profile sheets, even if the north arrow criteria must be violated to do so. The major portion of the street right-of-way along the alignment should be placed horizontally on the plan. Should this be impractical, the plan continuity may be broken and the match lines joined by a leader and the word IDENTICAL. Place a north arrow on each viewport when the orientation of the viewports varies.

If gravity hydraulic systems are to be constructed on a separate alignment from a street right-of-way, they shall be stationed increasing upstream. In combined projects where storm drain plans are combined with street plans, the alignment of the street should be followed where practical to maintain the same orientation.

## **Part. 4-4(B) Required Notation and Topography**

### **Section. 4-4(B)(1) Coordinate Systems**

The specified coordinate system/datum shall be denoted on maps (civil plans). The datum shall comply with the current datum used by COA, see Chapter 10, Surveying and Monumentation. The grid system used shall be described in the general notes and should also be identified in the survey control plan.

### **Section. 4-4(B)(2) Directional Indicators**

The direction of water flow of all waterways will be indicated by the standard flow symbol, pointing in the direction toward which the water moves.

### **Section. 4-4(B)(3) Benchmarks**

Plans shall denote benchmarks as reference points. The following types of benchmarks are required:

1. Base all elevations shown on the plans on City of Albuquerque current datum.
2. Note the location and description of the permanent bench marks used to extend level datum to the project in the designated location on the title block of each plan or plan & profile sheet. Identify bench marks by number, description, brief location, and elevation.
3. Show bench marks which are located within the area covered by the plans on the plan view in the proper location.
4. Designate all temporary bench marks used for control of the project on the plan view stating elevation, location and description. Show the nearest such bench mark on each sheet.
5. All elements in the site development plan will be laid out using geometric processes originating from a bench mark or other identifiable, permanent, physical element to facilitate staking by contractor. Grid layouts with dimensions shall not be used.

### **Section. 4-4(B)(4) Symbols**

All symbols and line work shown in the Topo shall be in accordance with the approved City of Albuquerque legend shown in Section 3 and 4 and drawn initially at a one to one scale. Symbols shall be scaled appropriately to conform to the construction documents drawing scale (i.e. 1"=20' or 1"=40'). In addition, all symbols shall be scaled for use in details or any other applications within the construction documents (i.e. 1"=5' or 1"=10').

### **Section. 4-4(B)(5) Right-of-Way**

All proposed and existing right-of-way and easement limits shall be shown on the plans in accordance with the approved City of Albuquerque legend shown in [Part. 4-3\(K\) Legend](#). Included in the plans shall be all subdivision names, property splits, and names of major businesses, schools, fire stations, private property signs, and other public facilities.

### **Section. 4-4(B)(6) Utilities**

All underground utilities and appurtenances shall be shown. This information will be used to coordinate with the appropriate utility owners within the project limits.

When information is available, the utilities shall be labeled with size and type. All existing storm drain and sanitary sewer manholes and all water valves shall be shown on the plans. Utilities that are abandoned or to be abandoned shall be indicated as well as those to be removed. Any utilities to be constructed prior to the bidding of the project shall be noted on the plans.

All existing and proposed street lights, utility poles, traffic signal poles and appurtenances shall be shown. Materials of existing poles shall be labeled or clearly indicated in the legend. All proposed poles, structures, and appurtenances shall be located by station and offset from the construction baseline.

Any City-owned or Water-Authority-owned utilities or appurtenances requiring relocation shall be included with the work order, including all necessary design and details, as well as dimensioning or stationing. Any existing utilities that are not owned by the City or Water Authority, and that need to be relocated, shall be clearly shown as "To be relocated by others [utility owner]."

### **Section. 4-4(B)(7) Existing Features**

For projects that require modifications to improvements or new improvements within the existing right-of-way the information shown on the plans shall include the following:

1. Record drawings research and sufficient elevations shall be obtained to indicate the direction of surface flow on all intersecting side streets, frontage roads, and paved parking lots. The direction of flow shall be shown by small arrows in the plan view.
2. The topo shall show elevations and cross-section data (Construction Centerline, Gutter Flow Line, Top of Curb, Right-of-way, and Grade Breaks) on side streets and beyond the ends of planned construction for a distance of 300 feet to provide information pertaining to drainage and existing conditions that may influence design. Where appropriate, some or possibly all of



this information may be needed on the plan sheets if tapers are needed, or drainage grading or inlet construction is required.

3. Where certain items such as water valves and sanitary sewer or storm drain manholes are supposed to exist according to plan records, but cannot be found in the field, they shall be labeled "NOT FOUND" or "NF" on the plans.
4. The topo shall show all existing parking curb stops within 10 feet of the proposed right-of-way line. Relocation of existing parking curb stops, and the addition of new safety curbs, where required, shall be shown and called out on the plans.
5. The topo shall show all features such as mailboxes, signs, light posts, walls, fences, gates, retaining walls, railroad ties, stone dividers, etc. All signs within the right-of-way shall be shown on the plans. All subdivision entrance structures and any associated lighting and power connections shall be shown. When these interfere with new construction they shall generally be noted for relocation or reconstruction.
6. All affected driveways and alleys shall be located and profiled. The surface material on each driveway shall be identified in the topographic notes and/or the plan view (e.g. "DIRT", "GRAVEL", "DECOMPOSED GRANITE", "AS-PHALT", or "CONCRETE"). If it will be necessary to reconstruct or re-grade a driveway, the reconstructed driveway connection will normally match existing materials and thickness.
7. Edges of existing driveways shall be depicted on the plan view from the roadway connection to a point at least 10 feet beyond the proposed right-of-way line. At driveways that may require significant alterations beyond the property lines, sufficient elevations beyond the property line shall be taken, and driveway profiles shall be prepared to ensure compliance with City of Albuquerque's standard driveway details.
8. Existing signing and striping, at least 500' beyond the project limits, shall be shown. This will provide information on how the signing and striping will need to be modified with the new improvements. This information should identify conflicting signing and striping that will need to be removed or replaced.
9. For projects that require new right-of-way or modifications to existing improvements directly adjacent to existing right-of-way, the topo shall provide, in addition to the information outlined above, the following information:
  - a. *All topography to at least 10 feet beyond the proposed right-of-way or easements. Standard symbols shall be used where applicable.*
  - b. *All information for canopies, overhead and ground signs, and building overhangs within 10 feet of the proposed right-of-way shall also be shown on the plans. The outline of the street-side face and corners of each building on property abutting the right-of-way shall also be shown on the plan view if any part of the building lies within 10 feet of the proposed right-of-way line.*
  - c. *The floor elevation of each building within 10 feet of the proposed right-of-way shall be shown in the plan view.*
  - d. *All berms and ditches within 10 feet of proposed right-of-way shall be shown in plan view. Toe and crest of berms and top and bottom of ditches shall be shown on the plans with spot elevations at minimum 50-foot intervals showing top of berm and ditch flow line. Flow lines of existing drainage ditches shall be shown in the profiles.*
  - e. *All existing landscape irrigation appurtenances within 10 feet of the proposed right-of-way shall be shown on the plans.*

- f. All signs within, and 10 feet beyond the right-of-way shall be shown on the plans. If signs are electrified, it shall also be noted, along with whether the electrical source is overhead or underground.
- g. All trees and shrubs within 10 feet of the proposed right-of-way and easements shall be shown on the plans. The tree trunk diameter shall be measured one foot above the existing ground. The City will determine the disposition of all trees and shrubs. If slight changes in alignment could be made to save valuable trees or the sidewalk could be realigned, it should be brought to the attention of the City as early as possible.

## **Part. 4-4(C) Cross Referencing Between Drawings**

All Drawings shall be cross-referenced using the Sheet Number located in the block of the border and the name of the plan sheet.

### **Section. 4-4(C)(1) Section and Detail References**

Sections shall be denoted with alpha characters. Details should use numbers for identification. A combination of alpha and numeric characters may be used, provided that the first character of a section is an alpha character and the first character of a detail is numeric. All alpha characters shall be capitalized. When referencing sections/details from another sheet, use characters unique to the drawing set (don't reuse letters/numbers).

### **Section. 4-4(C)(2) Project Phasing, Bid Lots, or Bid Alternatives (For City Projects Only)**

If the project will be broken up into various phases, the boundaries of each phase shall be clearly identified within the plan set. The line type and text that is to be used can be found in the City's standard Legend in Section 3.1. If the project will contain Bid lots or Bid alternatives that need to be a part of the bid phase then these areas shall be clearly identified using the same line style and text as when identifying the phases of a project, see [insert cross-reference].

All plan or plan & profile sheets and site grading plans submitted as part of a project package for DRC approval must be on City standard drawing sheets. All public and private rights-of-way, easements, property lines, and building lines must be shown. Points of connection to existing facilities shall be clearly shown. When the work area extends onto more than one drawing sheet, show match lines to other plan or profile sheets, along with sheet number.

All proposed work shall be dimensioned from right-of-way and property lines, or referenced with stations and offsets to a centerline or construction baseline as described above. All existing utility lines shall be clearly shown and identified, including type, material, size, and ownership. Utilities shall be shown using complex line type (e.g. "G" for gas, "W" for water, "SAS" for sanitary sewer, and "SD" for storm drain. Refer to [insert cross-reference] for standard line types for existing utilities.

## ARTICLE 4-5 PLAN SHEET CONTENT

The drawings are instructions to the contractor. They must be accurate and easily interpreted. Drawings shall be prepared so that they convey the complete meaning intended. A project plan package consists of, but is not limited to, the following sheets and contents collated as follows:

### Part. 4-5(A) Title or Cover Sheet

This page contains project title, vicinity map, zone atlas page, legal description, total square footage of project area, index, "Approved for Construction" signature block, general notes, logo and revision block with approval space. Blanks for separate work order numbers must be provided when applicable. A "special information" block needs to be located on the cover page of plan sets and specifications to accommodate information that may be required for specific projects, e.g. those projects funded or partially funded by state grants need to have the state project number placed on the title sheet/spec cover. The Cover Sheet shall contain the following information:

1. The City's logo, Project name, project limits/description, and COA project number. Center project title (name of subdivision, street, arroyo, area, etc.) within the border.
2. Locate vicinity map in upper right hand corner. Use legible scale for map. Standard Zone Atlas maps may also be used for preparing vicinity maps. Clearly mark the location of the project and ensure all street names surrounding the project are shown.
3. Locate index below PROJECT TITLE.
4. Locate signature block "Approved for Construction, City Engineer" in lower right hand corner and the project number and sheet \_\_\_ of \_\_\_.
5. If the project is being fully or partially funded by State, Federal, or other agency include the agency's logo and funding control number along the right hand side above the signature block.
6. The Consultant's professional engineer seal, placed in the designated area located near the right hand corner of the sheet.
7. The project number, project name, and the percent submittal of the plan set labeled along the right margin outside the border line, so when the plans are rolled up this information can be seen.
8. The appropriate signature lines, for City of Albuquerque and Water Utility Authority, and as applicable, AMAFCA, NMDOT etc.
9. If multiple projects with individual project numbers are to be packaged into one bid set, there shall be a Cover Sheet for each project number, plus a master Cover Sheet listing each project number and description in the set.
10. Bench Mark information shall note the location and description of the permanent bench marks used to extend level datum to the project in the designated location. The Bench Marks shall be identified by number, description, brief location, and elevation. This information shall be shown on each sheet within the plan set in the designated location within the border.
  - a. If temporary bench marks are used for control of the project, this information shall be shown on the survey control sheet, with the elevation, location and description.
11. If the plan is for a project going to public bid, also provide a block for plan set number in the lower right hand corner.

12. Place general notes near the right hand border, or provide them on a separate sheet. Show applicable Standard notes, which are available from the City of Albuquerque's website.
13. A logo may be placed as shown on the standard title page, [Title Page Template](#).
14. Provide a revision block as shown in the [Revision Block Template](#).
15. The Cover Page will be considered as sheet I.

## **Part. 4-5(B) Index of Sheets/Key Map**

The Index of Sheets/Key Map is the second drawing in the plan set. This sheet will provide the sheet index for the plan set as well as a key map to indicate where each sheet falls within the project limits. See the [General Plan Template](#) for sample plan. For simpler projects where only one plan view is needed, the key map may be eliminated and the Index of Sheets placed on the key or cover sheet.

### **Section. 4-5(B)(1) Index of Sheets**

The index of sheets will be shown in a table format made up of multiple columns and rows. The plan sheet name will be listed along the right hand side of the table and the corresponding sheet numbers will be shown along the left hand side of the table.

### **Section. 4-5(B)(2) Key Map**

The Key Map shall legibly show the entire project. The City Zone Atlas maps can be used for the key maps if so desired. The following information shall be indicated on the key map:

1. Project limits and corresponding stationing.
2. Street names for all major cross streets; or minor street names if there are no major cross streets in the vicinity of the project.
3. The portion of each street covered by each plan or profile sheet.
4. A key map legend to denote the paving plan and profile sheet break out.
5. A north arrow.
6. Sufficiently sized to be readable when printed at half-size.

## **Part. 4-5(C) General Notes/Legend Sheet**

The General Notes/Legend Sheet will be the third sheet in the plan set. This sheet shall contain all the general notes pertaining to the project in addition to the standard City of Albuquerque Legend. See [General Notes Template](#) for sample plan.

### **Section. 4-5(C)(1) General Notes**

The Consultant shall use the approved City of Albuquerque General Notes available on the City of Albuquerque website. The Consultant may add special notes as necessary for the specific project. The note additions should be identified under a separate header, "SPECIAL NOTES".

Notes that are not applicable to the project may be deleted at the discretion of the Engineer by striking through the line of text for all submittal leading up to the final submittal. At which time the notes can be removed from the plans for final signature. General notes shall not be used in lieu of supplemental general provisions or supplemental technical specifications.

### **Section. 4-5(C)(2) Legend**

The Consultant shall use City of Albuquerque's approved legend symbols consistently throughout the entire plan set. See [Part. 4-3\(K\) Legend](#) for a sample of the legend.

## **Part. 4-5(D) Summary of Quantities Sheet (Applicable to City of Albuquerque Projects Only)**

Each project shall contain a Summary of Quantities Sheet. This sheet consists of various tables showing the summary of each bid item number, description of each item, unit pertaining to the item, and a total for each item in the project. The Summary of quantities will be divided up into several tables related to the type of work being performed (i.e. roadway, drainage, water, sewer, etc.). See [Summary Quantities Sheet Template](#) for sample plan.

## **Part. 4-5(E) Survey Control Sheet**

All existing survey monuments/control points used to survey the project shall be shown on this sheet. The control point information will be shown as a physical location on a key map as well as in a table format. The identifier for the control point (CP) information shall consist of a letter and number combination (i.e. CP-1), northing and easting information for each point, elevation, and a brief description.

All adjacent streets and properties shall be clearly labeled with the appropriate street names and owner property names. The scale of the drawing should be denoted using the approved City of Albuquerque bar scale. The City's approved north arrow shall also be included on this sheet. See Survey [Control Sheet Template](#) for sample plan.

## **Part. 4-5(F) Horizontal Layout Sheet**

The Horizontal layout sheet should contain the following information: (See [Horizontal Layout Template](#) for a sample Plan)

1. The construction centerline and the bearings and distances along the construction centerline shall be shown.
2. Stationing along the construction centerline shall be shown.
3. North arrow and bar scale shall be shown along with the appropriate street name labels and adjacent property owner names.
4. Survey Control Points may also be shown if desired.

5. On curved sections, construction centerline stationing shall be shown along the centerline of the curve, and not along the tangent lines.
6. Curve data (radius, delta, tangent and curve lengths) shall be shown on same sheet as the curve. This information can be shown either near the curve or summarized in a table on the same sheet.
7. The proposed and existing hardscape features (i.e. curb, gutter, sidewalk) shall be the only line work shown in this sheet. All utilities, contours, signing and striping, etc. shall be turned off.

## **Part. 4-5(G) Removals Sheet**

Removal sheets shall be included in the construction documents when requested by the City. Each project shall be dealt with, on a case by case basis, as to whether removal sheets are necessary and will provide clarity to the plans.

For projects that are in well-established/developed areas of the City removal sheets should be included so that the detail of what is being removed is clear to the contractor.

The removal sheets shall identify the existing improvements that are to be removed or relocated to avoid conflict with the proposed improvements. Items that should be highlighted are the removal of asphalt, curb, sidewalk, striping, sidewalk ramps, driveways, utilities, vegetation/Landscaping, signs, structures, etc.

The scale of the removal sheets shall be chosen to clearly show what is to be removed. Additional details may be needed or incorporated as necessary for clarity. See [Removal Sheet Template](#) for sample plan.

## **Part. 4-5(H) Plat Sheet**

This sheet shall be provided in the plan set with a note indicating "FOR INFORMATION ONLY". See [Chapter 5 Recordable and Development Documents](#), for Plat Standards.

## **Part. 4-5(I) Approved Grading and Drainage Plan**

This drawing, which will be reviewed and approved separately through the process outlined in Section X shall be inserted into the plan set clearly indicated "FOR INFORMATION ONLY". This drawing shall include the following elements:

1. Site layout with existing and proposed contours
2. Elevations at property line corners in residential subdivisions, building pads, ponding area, along street frontage, and curbs and gutters
3. Locations and elevations of existing and proposed drainage courses
4. Locations and elevations of required retaining walls
5. Flow directions of on-site and right-of-way storm flows
6. Size (length, width and depth) of ponding areas

7. Cross slopes on walks, ramps, drives, parking, etc., shall all be indicated with an arrow indicating the direction of surface drainage and include the % of the cross slope.

### **Part. 4-5(J) Erosion Control Plan**

An approved Erosion and Sediment Control (ESC) plan and Stormwater Control Permit for Erosion and Sediment Control (ESC Permit) are required when the earth disturbance is 1.0 acres or greater, or for smaller sites developing on site conditions. See DPM [Chapter 6 Drainage, Flood Control and Erosion Control](#) for site conditions. The earth disturbance area includes disturbed areas of the site plus the Work Order. The approved Erosion and Sediment Control plan shall be included within the plan set. Submit plans and permit applications to the Stormwater Quality Engineer. The ESC Plan and permit are NOT required for projects wherein the owner is an MS4 Permittee (e.g. City of Albuquerque, AMAFCA).

### **Part. 4-5(K) Master Street Plan**

The Master Street Plan should contain the following information:

1. Location of streets with names.
2. Location of valley gutters with crown transitions .
3. Direction of storm runoff flows.
4. Street widths.
5. Accessible ramps - which must comply with prescribed City standards for accessibility.
6. Storm drain inlets.
7. Sidewalk easements and any other roadway easements.
8. Both proposed and deferred sidewalks shall be clearly distinguished.
9. Lot numbers or street addresses.

### **Part. 4-5(L) Typical Sections Sheet**

The typical section shall be shown such that it represents the existing and proposed conditions in one section. The existing conditions within the typical section shall be screened back. See [Typical Sections Template](#) for a sample Plan.

Typical sections shall be shown looking up-station. The station limits that pertain to each typical section shall be shown (i.e. STA XX+XX to STA XX+XX) along with the corresponding roadway name. All improvements and proposed grading to match existing shall be shown. The limits of the proposed and existing/ apparent right-of-way shall be shown, along with the construction centerline.

The appropriate dimensions for lane widths, median widths, sidewalk widths and available right of way should be shown. The existing and proposed pavement cross slopes shall also be indicated on the typical section. Street crown or cross slope and transition areas shall clearly be shown. Type of curb and gutters shall be shown, referencing City-Standard details.

The proposed pavement structural sections for the project shall be shown. The appropriate labels/information for each layer of the pavement section shall be provided.



At least one typical pavement cross section for each proposed street width and pavement type shall be included. Clearly show cross slopes for the entire section. Include adjoining structures in the section to indicate heights of new structure in relation to existing.

### **Part. 4-5(M) Environmental Sheet**

As a typical condition of utilizing Federally Funding, project specific Environmental Commitments are identified within the project's Environmental Document (EIS, EA, CE, etc.). These Environmental Commitments are any agreed-upon commitments to avoid, minimize or compensate for a social, economic or environmental impact. These Environmental Commitments should be included and listed within the Construction Plan set. These Environmental Commitments provide additional guidance, instructions, restrictions, and requirements the project must follow during construction.

### **Part. 4-5(N) Roadway Plans**

In general, most plan/profile layouts shall be shown on standard half plan/half profile sheets using the approved City of Albuquerque borders. In the case where steep grades or wide plan views prohibit plotting on these sheets, separate full plan and full profile sheets may be used. See [Roadway Plan Template](#) for sample Roadway Plans.

#### **Section. 4-5(N)(1) Stationing**

Centerline stationing shall be shown on plan and profile sheets. Stationing shall generally run from west to east, or south to north. Stationing will be at 100 foot increments with tick marks at 50 foot increments. Centerline stationing shall generally begin at Station 10+00 or higher to avoid "negative" stationing. Stationing call outs shall be perpendicular to the alignment stationing for all projects shall correlate with the paving project when feasible.

#### **Section. 4-5(N)(2) Horizontal Curve and Line Data for Left and Right Curb**

The horizontal curve and line data for the left and right curb shall be represented in a table format and be placed on the right hand side of the sheet within the "CONSTRUCTION NOTES" margin or within the plan view area.

The "CURVE AND LINE DATA" shall contain the following information:

<b>TABLE 4.5.6 CURVE AND LINE DATA</b>				
<b>NO</b>	<b>DELTA</b>	<b>TANGENT</b>	<b>ARC LENGTH</b>	<b>RADIUS</b>
<b>C1</b>				
<b>C2</b>				
<b>C3</b>				
<b>L1</b>				
<b>L2</b>				-
<b>C1</b>				-

1. The associated elevations, and begin and end stations, for the curve and line data shall be shown in the profile with appropriate labels used to identify this information (PC and PT).
2. Horizontal curve data must indicate stationing of PC, PT, radius, delta, length of curve and tangent. Detailed street information not adequately shown on the plat must be shown on the plans. The plat must be included in the plan set.
3. Crown and cross slope, if other than standard 2%, must be sufficiently detailed to assure accurate construction. Cross slope transitions must be clearly defined.
4. Use centerline stationing with right and left offsets to face of curb. Station median curbs similarly.
5. Provide stationing to the centerlines and dimensions of proposed driveway entrances.

**Section. 4-5(N)(3) Right-of-Way**

All plan views, horizontal control views, storm drainage plans, etc., shall show the limits of existing and new right-of-way, as well as any needed construction easements.

**Section. 4-5(N)(4) Sheet References**

Sheet number references for match lines and other related plan sheets such as references to storm drain plan sheets, median detail sheets, driveway details, ramp details, connector pipe profile sheets, etc., shall be noted on each individual plan sheet. This can be done in the plan view area or within the construction notes.

**Section. 4-5(N)(5) Profiles and Grades**

1. Separate profiles shall be shown for left curb and gutter (along flow line or gutter lip), construction centerline (crown), and right curb and gutter (along flow line or gutter lip). Elevations and stations at all grade breaks, curb returns, and intersections shall be shown. Street profile grades shall be shown as percentages to 2 decimal places. All grade breaks shall be identified by symbol and profile note.
2. The proposed construction centerline profile shall show the profile of the existing surface at the construction centerline. The proposed curb and gutter profiles shall show the existing surface line at the location of the new curb lines.

3. Vertical curve data must indicate VPC, VPT, VPI, length of curve, percent grade of tangents and K Value, and stationing and elevation of any high and low points.
4. Show existing ground at right-of-way lines if plans are not accompanied by other grading plans showing existing elevations. Curb profiles are to be run through intersections showing projected flowlines. Both curb lines may be shown on single profile, if clear. If clarity cannot be preserved, two profiles (individual curb lines) will be required.
5. Provide top of curb and flowline elevation at returns and valley gutters as shown in the Standard Details.
6. Crown and cross slope, if other than standard, must be sufficiently detailed to assure accurate construction. Transitions must be clearly defined.
7. Show true slopes and lengths of curb lines through horizontal curves.
8. Show curve data including radius, central angle and length along the flowline on all curves including curb returns. The same requirement applies to median curb.
9. The Consultant is responsible for designing the street such that private property drainage is not adversely affected. Sufficient elevations shall be taken and shown on the plans to ensure that the new curb grades will not adversely affect private property drainage. This survey information, its recording on the plans, and its use in setting proper street grades is extremely important. If, in the opinion of the City, this information is not sufficient to properly check the proposed grade, the plans will be returned to the Consultant to provide the required information.

### **Section. 4-5(N)(6) Driveway Information/Details**

Sufficient elevation information shall be obtained to ensure good driveway match to private property. Spot elevations on existing driveways shall be shown on plans where needed to show that the driveway match is adequate and does not violate compliance with City, State, or Federal requirements. The plans shall provide detailed driveway profiles where necessary to clearly how the driveway match shall be made (see [Roadway Plan Template](#) for more information on driveway details). Any driveway reconstruction that may need to occur beyond the right-of-way shall have temporary construction easements in place, with dimensions shown on the plans to cover the additional area required.

If a driveway grade must be changed, and there is a fence with a gate for this driveway, the plan shall determine if the gate/fence must be adjusted to function with the new driveway grade properly. If adjustment is necessary, the plan shall provide the necessary design and notations on the plans.

If requested by the City, the plan shall provide driveway profile worksheets to show how the proposed profile will meet requirements. In some cases, these profiles may be included in the design plans to clearly show a contractor how they are to be built.

Where significant cuts or fills are required to match proposed work to existing adjacent property, the cut or fill lines shall be shown on the plans. These general cuts and fills shall also be shown on the roadway typical sections.

Whenever possible, existing trees, fences or other structures shall be protected from significant cuts or fills. Where these cannot be avoided, the plan shall pro-

vide whatever design or plan notations may be necessary to remove, relocate or reconstruct conflicting items.

## **Part. 4-5(O) Geometric Details/Special Details**

1. Provide detail for all items that are not covered by the City Standard Detail Drawings. This may include standard drawings from other government agencies.
2. If City Standard Detail Drawings are referred to, the drawing number and revision number must be specified on the drawing.

### **Section. 4-5(O)(1) Geometric Details**

Geometric Details should provide the detailed curve and line data information for medians, sidewalk ramps, intersections, driveways, etc. The details shall contain information for slopes, elevations, stations, and offsets.

The driveway details shall provide plan and profile information to ensure that the maximum slope allowed by the City's Design Process Manual (DPM) is not exceeded. Each driveway detail shall be labeled with a center of driveway station and if applicable the property name.

The ramp details shall contain, at a minimum, information for slopes, elevations, line and curve data, stations, and offsets.

All information for curve and line data shall be provided in a table format and referenced by the standard curve and line annotations. See Geometric Details Template for sample plan.

### **Section. 4-5(O)(2) Specific Details**

Special details shall be included where necessary to clarify non-standard features in order to provide the contractor specific information. Such details are not covered by the City of Albuquerque Standard Drawings. This may pertain to such items as utilities, structures, retaining walls, cut off walls, etc. See [Roadway Plan Template](#) for sample plan.

## **Part. 4-5(P) Construction Traffic Control Details (Applicable to City of Albuquerque Projects)**

The traffic control plans are used to show existing site conditions, how bicycle/pedestrian and vehicular traffic will be maintained during construction, and proposed changes to an area. It will be up to the City's Project Manager to decide if Traffic Control Details/Layout Sheets need to be prepared for the project. The Consultant shall coordinate this with the City's Project Manager or DRC Chair for private development.

In the event that traffic control plans are prepared, the plans shall be submitted at 1"=20' unless otherwise approved by the City Project Manager. The only

exception to this scale shall be when the limits of the work may lend itself to be shown at a smaller scale. In this case, 1"=40' is acceptable.

## **Part. 4-5(Q) Signing and Striping Details/ Layout Sheets**

Pavement markings are used to convey traffic control information to the driver. Pavement markings may be used alone or to supplement other traffic control devices, such as signs and traffic signals. Ensure that the appropriate signs and signal controls are used in conjunction with markings where intended. Any markings that are no longer applicable may create confusion and shall be obliterated.

The following information shall be included in all signing and striping plans. The signing and striping shall be in accordance with the latest edition of the Manual of Uniform Traffic Control Devices (MUTCD), US Department of Transportation, and the Federal Highway Administration. See [Signing and Striping Plan Template](#) for sample plan.

The cover sheet for the signing and striping plans shall contain the general notes for signing and striping along with the following note:

**EXISTING CONDITIONS:**

The posted speed limit on \_\_\_\_\_ is \_\_\_\_\_.

The design speed on \_\_\_\_\_ is \_\_\_\_\_.

The plan symbol codes can be found in Appendix G for reference. These plan symbol codes simplify the pavement marking annotation needed to prepare plans. The plan symbols shall be used when preparing City of Albuquerque pavement marking plans.

### **Section. 4-5(Q)(1) General**

Signing and pavement marking design shall be shown in the same plan view. Plan sheets are to be double loaded plan view at a scale of 1" = 40', unless otherwise approved by the City Project Manager. The signing and markings shall use the City of Albuquerque standard plan symbol coding, see [Section. 4-5\(Q\)\(4\)](#).

Entire length of project is to be shown in plan view. "Typical Sections" representative of striping and/or signing will not be accepted.

Signing and pavement marking plans shall include all existing signing and pavement markings for a minimum of 300 feet past the limits of construction and shall include adequate transitions and tapers to maintain traffic at the design speed.

### Section. 4-5(Q)(2) Signage

All signs shall be stationed and referenced to the appropriate MUTCD sign designation with size noted. Stationing shall conform to the roadway construction centerline stationing. All signs shall be shown at a scale that is relative to scale of the drawing (i.e. 1"=40').

Existing signs will be screened back and dashed. Signs will be identified as either to remain, be removed, or be relocated. All existing advance or approach signing applicable to the project shall be field verified. Reference signs on plan sheet including location or station and note status of sign.

### Section. 4-5(Q)(3) Striping

Existing striping shall be fully shown (as screened lines), identified by type and width, and lane widths shall be dimensioned across roadway (i.e. 11', 12', etc.) and the length of all left and right turn lanes (i.e. 100', 160', etc.). All existing and proposed striping on the plans shall be shown graphically as they exist in the field (i.e. 10' stripe/30' gap).

All new striping shall be clearly identified noting color, line type and line width, include beginning and ending stations. Striping to be removed shall be identified on the plans.

All pavement markings (i.e. arrows, crosswalks, stop bars, stripes, etc.), shall be located by station and/or dimension lines. Show all advance traffic signal loops in the pavement (where applicable). This is critical in producing striping plans.

### Section. 4-5(Q)(4) Plan Symbol Coding

The MUTCD categorizes pavement markings as longitudinal or transverse markings. Longitudinal markings include: center lines, lane lines, edge lines, and dotted lines. Transverse marking include: diagonal lines, stop lines, crosswalk lines, arrows, and symbols. The meaning of these longitudinal and transverse markings is denoted by their color, line type, line width, and pavement marking pattern. The following examples outlined in the plan symbol coding that is to be used on the signing and striping plans prepared for the City of Albuquerque.

FIGURE 4.5.1



FIGURE 4.5.2



The plan symbol codes can be found in Traffic Control Plan Template for reference. These plan symbol codes simplify the pavement marking annotation needed to prepare plans. The plan symbols shall be used when preparing City of Albuquerque pavement marking plans

## **Part. 4-5(R) Traffic Signalization Details/ Design Sheets**

The traffic signal plans are used to show the existing signal design, proposed signal design and signal equipment to be removed or retained. All traffic signal plans shall be submitted at 1"=20'. Note that signal faces shall be shown on this plan in addition to the Traffic Timing and Phasing Plan.

The traffic timing and phasing plans should show signal timings, major items required at the intersection, a preferential phase diagram, and the signal faces used. See [Signal Plan Template](#) for Sample Plans.

### **Section. 4-5(R)(1) Traffic Signal General Notes & Legend**

The General Notes/Legend Sheet for Traffic Signal plans shall contain all the general notes pertaining to the signal plans in addition to the approved City of Albuquerque Traffic Signal Legend. See [Signal Plan Template](#) for sample plan.

The Consultant shall use the approved City of Albuquerque General Notes. The Consultant may add special notes as necessary for the specific project. The note additions should be identified under a separate header, "SPECIAL NOTES".

Notes that are not applicable to the project may be deleted at the discretion of the Engineering by striking through the line of text for all submittal leading up to the final submittal, at which time the non-applicable notes will be removed from the plans for final signature.

The City's General Notes can be obtained from the City of Albuquerque's website. The Consultant shall use City of Albuquerque's approved Traffic Signal Legend symbols consistently throughout the entire plan set.

### **Section. 4-5(R)(2) Equipment & Incidental items, Interconnect Requirements**

The Traffic Signal Equipment and Incidental Items, and Interconnect Requirements shall be in accordance with approved equipment and procedures as established by the City of Albuquerque's Traffic Engineering Department. See [Signal Plan Template](#) for Sample Plan.

### **Section. 4-5(R)(3) Traffic Signal Estimated Quantities**

Traffic signal item numbers and description are based on 'City Engineer's Estimated Unit Prices for Contract Items 2009' document by the City of Albuquerque or an updated version of the same. See [Signal Plan Template](#) for Sample Plan.



### **Section. 4-5(R)(4) Traffic Signal Plan**

The Traffic Signal Plan provides information on control cabinet, meter pedestal, service riser, signal poles and equipment's located on signal poles. Utilities, pavement markings, right of way, centerline, and stationing must be shown on this sheet. Pull boxes, conduits & conductors call-outs and requirements shall be shown on the Traffic Signal Cables & Conduits Sheets I and II. In addition, the Consultant shall determine and annotate the height measurements relative to existing power lines of traffic signal/appurtenances to ensure there is sufficient clearance and to avoid conflict during construction. See [Signal Plan Template for Sample Plan](#).

### **Section. 4-5(R)(5) Street "A" & Street "B" Traffic Signal Cables & Conduits- I**

This sheet shall show conduits and conductor requirements. Excel tables (TABLES\_COA SIGNAL STANDARDS.xls) provided in Appendix I may be used as a template. Call-outs for conduits, signal poles, and pull boxes shall be included on this sheet. Pole location instead of signal mast arm shall be shown on this sheet in order to maintain legibility of the sheet. See [Signal Plan Template for Sample Plan](#).

### **Section. 4-5(R)(6) Street "A" & Street "B" Traffic Signal Cables & Conduits- II**

This sheet should show wiring diagrams and requirements to provide sufficient information such that traffic signal wiring is performed by the contractor according to the City of Albuquerque standards. See [Signal Plan Template for Sample Plan](#).

### **Section. 4-5(R)(7) Traffic Signal Blocks**

Typical traffic signal equipments are provided as blocks in the COA SIGNAL BLOCKS.dwg file. Note that not all the equipments are drawn up to the scale to maintain legibility on the plan sheets. See [Signal Plan Template](#) for Sample Plan.

## **Part. 4-5(S) Lighting Details/Design Sheets**

Streetlight plans shall convey information about the type, wattage, and location of streetlights required to be installed with various types of residential, commercial, and industrial development projects. Streetlight plans prepared by the developer's engineer are reviewed by the city to optimize public street illumination for traffic safety purposes, without imposing undue public maintenance and energy costs. A well designed public streetlight system enhances public safety while contributing to community quality of life. See [Lighting Plan Template](#) for Sample Plan.

## **Part. 4-5(T) Roadway Cross Sections**

Street cross sections may be required, if terrain or design problems are encountered.

In some situations, cross sections are helpful for measurement of earthwork volumes in roadway construction. They are profile views of the ground, perpendicular to the centerline or base line, and indicate ground elevations at points of change in the ground slope. Sections should be taken at intervals of 50 ft along the centerline of the roadway. See [Roadway Cross Sections Template](#) for Sample Plan.

The following items shall be shown and annotated on each cross section:

1. Existing Ground Surface (Dashed)
2. Proposed Finished Ground Surface (Continuous)
3. Cross Section Station (at every 50' station)
4. Construction Centerline (Labeled)
5. Existing or proposed Right-of-way (Labeled)
6. Proposed elevation at the centerline
7. Cross slope along the finished grade of the roadway.
8. Elevations and offsets at the top of curb or edge of pavement
9. Slope needed to tie into existing ground (i.e. 4:1, 3:1, etc.)
10. Volume of cut and fill, when required by the City Project Manager

Cross sections may or may not be required for submittal with every project for the City of Albuquerque. The City Project Manager and Consultant will determine if the preparation of cross sections will be beneficial to the project.

## **Part. 4-5(U) Drainage Details**

### **Section. 4-5(U)(1) Utilities**

In plan and profile, existing and proposed underground utilities shall be labeled according to size and type, when feasible. Corresponding alphanumeric labels shall be shown for each utility and depicted in the legend. If the utility is an underground conduit, give all the details such as number of ducts and whether or not the conduit is encased in concrete. Any known utilities to be constructed prior to the project shall be shown and so indicated. Conflicts between existing utilities and proposed construction shall be identified. Utilities that are abandoned or to be abandoned shall be indicated as well as those designated to be relocated or removed.

The engineer shall contact the appropriate utility if any questions arise about types or locations of underground facilities. The minimum vertical clearance between a proposed storm drain and all existing utilities shall be shown in the profile. Above ground utilities such as power poles, light poles, guys and anchors, irrigation structures, utility pedestals, transformers, switching cabinets, gas regulators, waterline back-flow prevention units, etc. shall be called out including size and pad elevation, shown in plan, and stationed relative to the adjacent road construction centerline from the street side face of the utility (e.g. 12+33 R 32').

When below ground appurtenances (utilities, monuments, tanks, valve boxes etc.) depicted on As-Built or "Record" drawings can not be field located, they shall be shown and labeled as "not found".

A pothole table along with the public utility easements (PUE) information shall be shown on each sheet as applicable with x, y, and z elevations.

### **Section. 4-5(U)(2) Right-of-Way**

The plan view of the plan and profile, horizontal control, paving plans, etc shall show and label the limits of existing and new right-of-way, as well as any needed construction easements.

### **Section. 4-5(U)(3) Sheet References**

Sheet number references for match lines and other related plan sheets such as references to paving plan sheets, median detail sheets, driveway details, ramp details, connector pipe profile sheets, etc. shall be noted on each individual plan sheet. This can be done in the plan view area or in the area where the construction notes are located under the heading of "GENERAL NOTES".

### **Section. 4-5(U)(4) Storm Drainage and Profile Drawings**

The appropriate level of detail and information (elevations) should be provided to determine drainage patterns. In addition, information to determine that an adjacent property's existing drainage pattern will not be adversely affected should be included.

A plot of hydraulic grade line profile for storm drain pipe 18 inch or larger shall be provided. The profiles shall be submitted in summary form in plan and profile, intended to highlight the general alignment and hydraulic connectivity of the system herein referred to as the Hydraulic Grade Line Profile Sheet(s). Profile slopes shall be shown in percent to two decimal places.

The following data shall also be included with the storm drain profiles:

1. Horizontal and vertical alignment of the storm drains and storm drain pipe size, material type, length and slope of pipe.
2. Stationing of storm drain line when independent of street stationing must be increasing upstream of flows. If storm drain is depicted on the street plan, presentation may be as for sanitary sewers.
3. Hydraulic gradient, design flow and velocities are required on design review plans
4. The finished street grade over the storm drain pipe
5. The proposed pipe profile
6. Stationing (by angle and distance if necessary), invert elevation of all lines, the type, size, Manholes/Junction structures. Also provide rim and invert elevations at all existing storm drain manholes.
7. Station catch basins at "Point of Measurement" as shown on COA Standard Drawing Details, and tie to street centerline. Also, show type, invert elevations, top-of-curb elevations, grate elevations, type, length, and slope of connection pipe (in percent, to two decimal places).
8. Connector pipe
9. Pipe collars

10. Prefabricated pipe fittings
11. Other drainage appurtenances (headwalls, trash racks, drop inlets, hand rails, pipe supports, etc.).
12. Location of all other utilities crossed

### **Section. 4-5(U)(5) Catch Basins and Connector Pipe Information**

All catch basin structures and connecting piping shall be shown, detailed, and specified in accordance with the following:

1. Catch basins or other drainage structures shall reference the City of Albuquerque standard drawing number; if other structures are used (e.g., NMDOT), details shall be included in the plan set.
2. Gutter, grate, and top-of-curb elevations shall be shown.
3. Catch basins shall be stationed at the "Point of Measurement" shown on the COA standard drawings, and shall be tied to the street centerline.
4. Connector pipe inverts shall be shown at the catch basin and at the connection to the main-line storm drain, as well as any grade breaks.
5. If there are more than two connecting pipes, specify spatial orientation of the connection pipe with respect to the manhole (e.g., NE, NW, S, E).
6. Show the invert elevation at the outlets of all catch basins to the nearest 0.01 foot.
7. Specify pipe size, material, and slope (in percent to two decimal places).
8. Show in profile all utility crossings that may be in conflict with the proposed alignment.

### **Section. 4-5(U)(6) Utility Crossings**

All utilities (existing and proposed) perpendicular to the proposed improvement shall also be shown on the profile sheet. Utilities requiring adjustment to clear conflicts shall be shown and noted on the profile along with their potholed elevations.

Utilities larger than 12-inches in diameter shall be drawn to scale (show the size of the pipe) in the plan view. Utilities 12-inches or smaller in diameter can be drawn as a single line in the plan view.

### **Section. 4-5(U)(7) Stand Alone Drainage Plans**

All the above criteria apply, in addition to where new street paving work joins existing side streets, pavement crown and gutter elevations shall be shown in plan view for a minimum of 100 feet beyond the curb return on the side street. Where new street paving work joins an existing street linearly, existing pavement crown and gutter elevation shall be a minimum of 200 feet beyond the new work to ensure proper drainage and smooth ride for vehicular traffic.

### **Section. 4-5(U)(8) Channel Plans**

The design and layout of channels shall be shown in both plan and profile views to illustrate the horizontal and vertical alignment. The dimensions of the walls, side slopes and bottom shall be included, along with the slope (grade) of the channel and the available right-of-way.

The profile of the channel shall include the following:

1. Horizontal and vertical location of channel, Invert Elevations, slope, top of channel and bottom of berm.
2. All existing and proposed utility information, including type, invert information, top of concrete channel, and berm profiles, etc.
3. Stationing shall be along the centerline, increasing upstream, regardless of north arrow orientation.
4. Transitions along the channel shall be clearly identified and detailed in both plan and profile views.
5. The water surface elevation, design flows, and velocities shall be shown on the plans.
6. Intersection of lateral drainage.
7. Supplement channel design on plan and profile with corresponding cross sections.
8. Clearly detail and tie transitions in both plan and profile.
9. Show the horizontal location of all changes in type of material, cross section, horizontal and/or vertical alignment, of all cutoff walls, inlets to the channel, and all structures designed to change the flow characteristics to the nearest 1.0 ft. of the actual location.
10. Show elevations on the top of the side walls or top of the bank in earth channels and the centerline of the channel for all points as defined in 2.b to the nearest 0.1 ft. of the actual elevation.
11. Revise channel cross sections to show the actual elevation to the accuracy as defined in 2.c at each right-of-way line, at the top of bank or side wall on each side, at the bottom of bank or side wall on each side and at the centerline of the channel.
12. Show the length of the channel between points as defined in 2.b to the nearest 1.0 ft. of the actual length.
13. Show the slope on the centerline of the channel between all changes in vertical alignment to the nearest 0.01 percent (0.0001 ft./ft.).

### **Section. 4-5(U)(9) Channel Cross Sections**

For simple channels, a typical channel section is required that shows the geometry of the channel, along with material types and thicknesses necessary to clearly reflect the design. When complexity or length of project warrants, location-specific cross-sections shall be provided to depict the changing conditions along the length of the project. These specific cross-sections shall be in accordance with the following.

1. All cross sections for work within right-of-way or easements must be drawn to scale showing existing ground and proposed construction. Sections should extend into adjacent properties in order that unusual terrain or existing building data can be analyzed. Draw cross sections so that stations increase from the bottom of the sheet toward the top.
2. Station each section clearly along the centerline increasing upstream.
3. Indicate existing ground profile at each station.
4. Station the beginning and ending points of a project and draw cross sections for both the stations.
5. Show cross sections of streets, alleys, drainage facilities as looking towards the increasing stationing. Show property lines on cross sections and label as north, south, east or west.
6. Show the type of material, bank or side wall slope and dimensions of all channels constructed.
7. Proposed channel configuration at the station.

8. Areas of cut and fill.
9. Quantities of cut and fill between stations as directed by the City Project Manager.
10. Elevations of channel invert and top of channel.
11. Show the project name, stations covered on the cross section sheet and sheet numbers at the bottom right of the cross section sheet.

## **Part. 4-5(V) Utility Sheets**

### **Section. 4-5(V)(1) Master Utility Plan (Water, Sewer and Storm Drain)**

The water and sewer plan and profile sheets shall be prepared in accordance with the Water Authority (ABCWUA) CAD requirements or as directed by the Water Authority. See [Water and Sewer Template](#) for Water and Sewer Plan samples. All other plans shall conform to the Water Authority CAD standards.

1. Location of sewer line.
2. Size of sewer pipe. The type of pipe shall be specified or the plan may contain a note which states: "All sewer lines in this project shall be constructed of DIP, HDPP, HOPE, or PVC unless specified otherwise."
3. Location, type, size and length of service connections (Provide tables for multiple services).
4. Required elevations for manholes (Rims, Invert (in) and Invert (out))
5. Connection points to existing system.
6. Other utilities crossed or to be crossed by proposed line (Show the separation distance.)
7. Location of water line.
8. Size of water pipe. The type of pipe shall be specified or the plan may contain a note which states: "All waterlines in this project shall be constructed of DIP, CCYL or PVC unless specified otherwise."
9. Connection points to existing system.
10. Location of fire hydrants.
11. Pressure zone lines, if applicable.
12. Service locations, pressure reduction valves and air pressure release valves.
13. Location of meter boxes (Provide tables for multiple services).
14. Other utilities crossed or to be crossed (Specify separation when less than 3 ft.).
15. Location of all storm drain structures and pipe sizes.
16. Location of all utility easements and right-of-way lines.
17. Location of lighting, signal poles and other appurtenances.
18. Line widths shall be heavier than surrounding information.
19. Reference sheets for layout.

### **Section. 4-5(V)(2) Water Lines**

Water plans and profile drawings shall be prepared per Water Authority requirements in accordance with the following:

1. Stationing of water lines should correspond to the stationing of the street centerline if the street is new construction under the same contract as the water line. Show horizontal and vertical alignment of water lines. Vertical alignment may be by reference to top of curb. Identify depth of cover from finished grade for all of waterlines. If a public/private Water Authority ease-

- ment is required, the width of the easement shall be shown with a place for the recording information.
2. Show the type of material including class or code and internal diameter of all pipe installed by general note.
  3. Show the curve data or the amount of deflection (ft./ft. of pipe) and the direction of such deflection when the horizontal or vertical alignment of the pipe is changed by deflection of the joints.
  4. Identify the horizontal location (to the nearest 1.0 ft.) all fittings, restrained joints, valves, valve boxes, meter boxes, fire hydrants, and other applicable line features by type, size and possibly elevation, where necessary. Indicate material type and SDR where applicable as well as tracer wire location. All valves, fire hydrants, meter boxes, water manholes, and vaults require spatial coordinates to note their respective locations on the drawings. Coordinates shall be provided in the coordinate system stated in Section 2.C. Valve elevations shall be provided at both the top of the valve box cover, as well as the operating nut. An enlarged detail must be included when multiple fittings and/or valves are installed as a unit or when clarity of the location of the various items listed above cannot be obtained on standard plan and profile views.
  5. For multiple water meters, fire hydrants, water valves, water manholes, and vaults, use tables to show location, stationing, and spatial coordinates (x,y, and z coordinates) to note their respective locations on the drawings. Coordinates shall be provided in the coordinate system stated in Section 2.C. (Provide coordinate tables during plan review stages with space to fill in coordinates, but actual coordinates are not required to be shown until record drawings are submitted.) Where backflow preventors are required, show or note where they will be located.
  6. Show the invert elevation of all fittings, valves and changes in grade of the pipe for lines 16 in. diameter and larger, top of cover elevation for all valve boxes not in paved streets and bottom of flange elevation on all fire hydrants to the nearest 0.1 ft. of the actual elevation.
  7. Show the size and type of joint of all valves installed. For valves 16 in. and larger, show the number of turns required for stop to stop operations. If pressure relief valves or surge valves are installed, show the location of all bypass valves, fittings and/or discharge lines in an enlargement.
  8. Show the location of all anodes installed and all non-galvanic joints.
  9. Locate fire hydrants by station or tie to a centerline or property line with a distance to the hydrant from centerline shown. The elevation at the bottom of the flange must be shown. If an easement is required, the dimensions of the easement shall be shown.
  10. Indicate water pressure zone lines, if applicable.
  11. If the project is to be separated into several construction phases, such as master plan water line and normal distribution system, show the points or lines of separation.
  12. For all non-pressure connections to existing water lines, a water shutoff plan needs to be provided with an area map. Additionally, in the Construction Notes section, there should be a link to the seven (7) day line shutoff request.
  13. If San Juan Chama lines are within ten (10) feet of any proposed waterline construction involved in the excavation, an Administrative order Water Authority permit will be required to work near the San Juan Chama lines. Forms are available on the Water Authority website.



14. Show the tubing diameter and type of material, including class or code, installed in each service connection. General notes stating types of material are acceptable when the same materials are used throughout.
15. Show special fittings in sufficient detail to facilitate the future maintenance or replacement.
16. Show the type of blocking, if blocked, or the type of restraint used for all fittings, joints and valves requiring restraint. If the same type of blocking or restraining is used, general notes will suffice.
17. Show the length of pipe between tees and/or crosses to the nearest 1.0 ft. of the actual length.
18. Show and dimension all valves added to adjacent systems necessary to isolate the new system.

### **Section. 4-5(V)(3) Sanitary Sewer**

Sanitary sewer plans and profile drawings shall be prepared per Water Authority requirements in accordance with the following:

1. Show horizontal and vertical alignment of the sewer line. The sewer will generally be located along the centerline of the street. Also include size, type, length and slope of all pipe installed in sewer mains, service connections and risers as measured between centerlines of manholes.
2. Sanitary sewer lines may be shown by means of reaches giving the distance and slope of the line between centerlines of manhole barrels. For large diameter lines or for special circumstances where invert elevations at face of manhole are critical, additional notation may be required.
3. Show the following information for all sanitary sewer manholes: location of the manhole tied to street centerline stationing (by angle and distance if not on street centerline); invert elevation of all connecting lines; rim elevation, material type and size. Specify invert elevations by showing "invert (in)" and "invert (out)" with a 0.1 foot difference in elevation between inverts, where possible. Show manhole lid/rim elevations. Indicate flowline directions.
4. Show all proposed sanitary sewer service lines. Information required: size, material type, length, invert at property line. When multiple service lines are required, provide an SAS Table showing the pertinent information.
5. All sanitary sewer manholes, cleanouts, and vacuum valve pits require spatial coordinates (x,y, and z coordinates) to be noted for their respective locations on the drawings. Coordinates shall be provided in the coordinate system stated in Section 2.C. (Provide coordinate tables during plan review stages with space to fill in coordinator, but actual coordinates are not required to be shown until record drawings are submitted.) Show location of the manhole tied to street centerline stationing (by angle and distance if not on street centerline). Show manhole lid/rim elevation, invert elevations for all connecting lines within each manhole, and indicate flow directions, For cleanout and vacuum pits, show vertical data of lid or cap as well as invert elevations. Show all proposed sanitary sewer service lines with required information including size, material type, length, and invert at property line.
6. Show the horizontal location of the center of all manhole barrels or junction boxes, the dead end of each sewer main or stub, the end of each service connection and all changes in the type of pipe material used for sewer mains to the nearest 1.0 ft. of the actual location.
7. Show invert elevations of all pipe (inlets and outlets) within each manhole to the nearest 0.1 ft. of the actual elevation when the slope of the pipe

exceeds 1% or to the nearest 0.01 ft. where the slope of the pipe is less than 1%.

8. Show the invert elevation at the end of each service connection to the nearest 0.1 ft. of the actual elevation. This may be accomplished by revision of tables if originally presented in tabular form.
9. Indicate the type and diameter of all manholes and wall type (e.g., precast, block or poured in place) and the dimensions of all junction boxes on the drawings for each manhole or junction box or by general note.
10. Show the rim elevation of all manholes to the nearest 0.1 ft. of the actual elevation.
11. Show the length of pipe between manholes (measured center to center of manholes), the length of all dead end stubs, the height of each riser and the length of each service connection to the nearest 1.0 ft. of the actual length.
12. Show the slope of the pipe between manholes and on dead end stubs by actual slope to the nearest 0.01 percent (0.0001 ft./ft.).
13. When a new manhole is constructed around an existing sewer line, show the distance to the center of the existing adjacent manholes to the nearest 1.0 ft. of the actual distance.
14. Show the curve data, or the amount of deflection (ft./ft. of pipe) and the direction of such deflection when the horizontal or vertical alignment of the pipe is changed by deflection of the joints.

## **ARTICLE 4-6 RECORD DRAWING CRITERIA**

Upon completion of construction, record drawings shall be prepared and submitted for review and approval. They shall reflect all changes from the original, approved construction drawings, including sizes, materials, horizontal locations, and elevations as applicable. The record drawings may be prepared by manually depicting all as-built information on the original construction drawings, or may be prepared electronically with paper copies submitted. Regardless of the method chosen, the original, approved construction drawings shall be used as a basis, with all changes shown so the line work and labeling for the as-built conditions are distinctive and easy to read, as well as legible and fully comprehensible. Each drawing sheet shall be stamped "As-Built" or "Record Drawing," with the date of preparation shown.

The original drawings bearing the original approval signatures must be used in the preparation of the record drawings. If such drawings cannot be revised to produce a clear and legible record, new drawings must be prepared and clearly marked "Redrawn for Record Purposes." Originals must be marked "revised" and submitted with the new drawings. The use of drawings incorporating aerial photographs in the plan view of a plan & profile sheet should be avoided due to the difficulty in obtaining acceptable copies of the microfilmed record drawing.

### **Part. 4-6(A) General Criteria**

The applicable sections of the following criteria govern the type and accuracy of the information required on the record drawings for all construction work which is to be accepted by the City. It is intended that most items for record drawings can be obtained by verification of compliance to design at time of construction and that resurvey should only be required in instances of substantial departure from design.

1. Show the new construction as actually accomplished on each drawing in heavy solid lines in both the plan and profile views.
2. Show the horizontal location, elevation, size, type of material and nature of all discovered underground utilities or obstructions. Facilities existing prior to the project are to be shown in a thin dashed line in both the plan and profile as required to indicate the continuity of the system.
3. The horizontal location information for all facilities within a public right-of-way or easement must be based on centerline stationing and centerline offsets. Sufficient ties to existing property corners or other right-of-way control monuments must be provided to clearly establish the actual location of such facilities.
4. Base all elevations on City of Albuquerque control monuments as shown on the plans.
5. Identify on each plan and/or profile sheet all revisions to the construction which occurred during construction by placing a revision symbol and number at the location on the drawing where the change occurred and by recording all required information in the revision block provided. Identify the limits of all revisions on the drawings.
6. Where the as-built horizontal or vertical location of any facility or portion thereof differs from the location shown on the construction drawing by

more than 10% of the respective scale of the drawing, that portion or portions of such drawing shall be replotted to show the true location on the record drawings. Design lines should remain, where possible, to indicate magnitude and nature of change.

7. Record the information required in the as-built information block after the record drawings have been prepared.

## Part. 4-6(B) Digital Record Criteria

At the end of construction, the signed Record Drawings shall be submitted in .pdf format to the Department of Municipal Development Construction Services Division (DMD/CSD) for roadway projects and the Planning Department's Design Review and Construction Section (DRC) for private development of public infrastructure within the City right-of-way and/or easements. In each case, the following digital record criteria shall be submitted:

1. A single, multiple page, image based, electronic PDF file containing one .pdf sheet for each sheet of the project drawing plan set. To be named (ProjectNumber).pdf.
2. The resolution should be no less than 300 dpi.
3. A Separate CD containing the Projects "Base File". The base file drawing information shall be in CAD (.dwg) and submitted to the City's Project Manager.
4. Each sheet should be oriented as if you are reading the drawings on your desk (Top to bottom, left to right, no rotated images).
5. Each sheet of the single multiple-paged PDF should be numerically ordered according to the plan set.
6. The Title Block "as-built information" block on each sheet shall be fully completed.
7. Each sheet within the plan set shall be stamped/marked in large, red, bold text "RECORD DRAWING". This stamp/text should be placed at or near the bottom right hand corner or the sheet near the title block.
8. The cover sheet shall contain the "RECORD DRAWING CERTIFICATION" along with the engineer's or architect's seal.
9. The "RECORD DRAWING CERTIFICATION" for the construction of infrastructure for the engineer and surveyor shall read as follows:

I, _____, of _____, A LICENSED <small>ENGINEER'S NAME</small> <small>COMPANY NAME</small>
PROFESSIONAL ENGINEER IN THE STATE OF NEW MEXICO, DO HEREBY CERTIFY, TO THE BEST OF MY KNOWLEDGE AND BELIEF, THAT THE INFRASTRUCTURE INSTALLED AS A PART OF THIS PROJECT HAS BEEN INSPECTED BY ME OR BY A QUALIFIED PERSON AND HAS BEEN CONSTRUCTED IN ACCORDANCE WITH THE PLANS AND SPECIFICATIONS APPROVED BY THE CITY ENGINEER AND THAT THE ORIGINAL DESIGN INTENT OF THE APPROVED PLANS HAS BEEN MET, EXCEPT AS NOTED ON THE RECORD DRAWINGS. THIS CERTIFICATION IS BASED ON THE INSPECTIONS CONDUCTED AND AS-BUILT SURVEY PERFORMED BY
_____, ON _____ <small>SURVEYING COMPANY</small> <small>DATE</small>

I, \_\_\_\_\_, A LICENSED NEW MEXICO PROFESSIONAL SURVEYOR NO. \_\_\_\_\_, DO HEREBY CERTIFY THAT THIS AS-BUILT WAS BASED ON AN ACTUAL GROUND SURVEY BY ME OR UNDER MY DIRECT SUPERVISION; THAT THIS AS-BUILT SURVEY WAS PERFORMED IN THE MONTH OF \_\_\_\_\_; THAT IT MEETS ALL REQUIREMENTS LISTED UNDER THE STANDARD DRAWINGS AND STANDARD SPECIFICATIONS FOR SURVEYING ISSUED BY THE ENGINEER OF RECORD AND THAT IT IS TRUE AND CORRECT TO THE BEST OF MY KNOWLEDGE AND BELIEF.

- 10. For City of Albuquerque jobs, the cover sheet shall contain the approval from the DMD/CSD construction engineer of record for the project using the following signature block:

APPROVED AS RECORD DRAWINGS  
DMD/CSD  
CITY CONSTRUCTION ENGINEER  
  
DATE: \_\_\_\_\_

- 11. If the City's DMD/CSD is performing the prime role as the inspection team on the project the following record drawing certification must be used:

I, THE UNDERSIGNED, A REGISTERED PROFESSIONAL ENGINEER IN THE STATE OF NEW MEXICO, DO HEREBY CERTIFY THAT THE INDICATED RECORD DRAWINGS ARE BASED UPON INFORMATION PROVIDED BY THE CONSTRUCTION CONTRACTOR IN THE FORM OF THE REDLINED CONSTRUCTION DRAWING MARKUPS TO THE ORIGINAL DESIGN DRAWINGS. THE TRANSFER OF INFORMATION HEREIN IS TRUE AND CORRECT TO THE BEST OF MY KNOWLEDGE AND BELIEF. HOWEVER, I HAVE NOT VERIFIED THE ACCURACY AND/OR COMPLETENESS OF THE INFORMATION PROVIDED BY THE CONSTRUCTION CONTRACTOR AND SHALL NOT BE RESPONSIBLE FOR ERRORS AND OMISSIONS THAT MAY BE INCORPORATED AS A RESULT OF ERRONEOUS INFORMATION PROVIDED BY OTHERS. ALL INFORMATION INCLUDED VERTICAL AND HORIZONTAL DIMENSIONS SHOULD BE FIELD VERIFIED PRIOR TO USE ON FUTURE PROJECTS.

\_\_\_\_\_  
NAME

\_\_\_\_\_  
DATE

- 12. All drawings in the project set must be clearly marked "Record Drawing." A Registered Professional Engineer must affix his seal and a certification bearing his signature. A Registered Land Surveyor may certify as to position. This certification must state that the drawings have been revised in accordance with information furnished by to reflect the construction as actually accomplished.
- 13. Submit the record drawings and one print of each sheet to the City Engineer for review.

# CHAPTER 5

## RECORDABLE AND DEVELOPMENT DOCUMENTS

This chapter presents detailed specifications for the preparation of significant development related documents, which ultimately are recorded with the County Clerk or filed in the records of the City. Detailed requirements for drafting, drawing material, and the organization of recordable documents are covered as follows:

### CONTENTS

<b>GOVERNING REGULATIONS.....</b>	<b>147</b>
<b>ARTICLE 5-1 GENERAL REQUIREMENTS FOR ALL PLATS .....</b>	<b>147</b>
Part. 5-1(A) Nature and Purpose of Plat .....	148
Part. 5-1(B) Title of Plat.....	148
Part. 5-1(C) Date of Plat.....	148
Part. 5-1(D) Location Map / Zone Atlas Map Number .....	148
Part. 5-1(E) Scale and North Arrow .....	148
Part. 5-1(F) Plat Boundary Lines.....	148
Part. 5-1(G) Tie to Permanent Survey Monuments.....	149
Part. 5-1(H) Existing Easements.....	149
Part. 5-1(I) Existing Public Right-of-Way.....	149
Part. 5-1(J) Total Area of Plat.....	149
Part. 5-1(K) Monument Description and Location .....	149
Part. 5-1(L) Special Flood Hazard Areas.....	150
<b>ARTICLE 5-2 PRELIMINARY PLAT REQUIREMENTS .....</b>	<b>150</b>
Part. 5-2(A) Scale.....	150
Part. 5-2(B) Proposed Monumentation .....	150
Part. 5-2(C) Existing Conditions .....	150
Part. 5-2(D) Proposal Elements .....	151
<b>ARTICLE 5-3 FINAL PLAT DETAILED REQUIREMENTS.....</b>	<b>151</b>
Part. 5-3(A) Scale.....	151
Part. 5-3(B) Monuments .....	151
Section. 5-3(B)(1) Subdivision Control Monuments.....	152
Section. 5-3(B)(2) Permanent Survey Monuments.....	152
Section. 5-3(B)(3) Bench Marks.....	152
Section. 5-3(B)(4) Existing Monumentation.....	152
Part. 5-3(C) Plat Boundary .....	152
Part. 5-3(D) Plat Area .....	153
Part. 5-3(E) Reference to Federal Rectangular System .....	153
Part. 5-3(F) Interior Data.....	153
Part. 5-3(G) Exterior Data .....	154
Part. 5-3(H) Subdivision Data .....	154
Part. 5-3(I) Metes and Bounds Description / Legal Description .....	154

Part. 5-3(J) Consent and Dedication Statements..... 154  
Part. 5-3(K) Certifications ..... 155

**ARTICLE 5-4 GRANT OF DRAINAGE EASEMENT ..... 157**

**ARTICLE 5-5 DRAINAGE COVENANTS..... 157**

**ARTICLE 5-6 GRAPHIC STANDARDS ..... 158**  
Part. 5-6(A) Materials..... 158  
Part. 5-6(B) Drafting Standards..... 158

**ARTICLE 5-7 ACCEPTABLE FORMS OF LANGUAGE..... 159**  
*Section. 5-7(B)(1) Free Consent and Dedication..... 159*  
*Section. 5-7(B)(2) Surveyor's Certification..... 160*  
*Section. 5-7(B)(3) Sample Signature Block for Plats..... 160*



The major and most significant document discussed is the Final Plat as required by the Integrated Development Ordinance (IDO) of the City of Albuquerque. The preparation of a preliminary plat is also discussed in detail since the preliminary plat, when approved by the Development Review Board (DRB), becomes the basis for preparation of the Final Plat.

Examples of appropriate dedication statements on plats and formats for grants of easement by separate instrument for certain purposes, are also included.

## **GOVERNING REGULATIONS**

The Integrated Development Ordinance (IDO) ordinance is the primary regulation governing plat preparation for subdivided land within the jurisdiction of the City of Albuquerque planning and platting authority. Additional requirements related to processing and recording are promulgated by the Bernalillo County Clerk.

### **ARTICLE 5-1 GENERAL REQUIREMENTS FOR ALL PLATS**

“Plat” means, for the purposes of this section, a formal graphic presentation of subdivided land prepared in the manner specified herein and containing required descriptions of subdivided land, acknowledgment by owners of consent to subdivision, dedications, and certification by the plat preparer. This section covers requirements for:

1. Preliminary Plats which are often required as a step toward Final Plat preparation and approval;
2. Plats intended for abbreviated procedure, which are generally Final Plats involving minor subdivisions or minor boundary changes or are for a limited special purpose and which by their nature are appropriate for abbreviated processing; and
3. Final Plats of proposed subdivisions of land submitted for approval to the Development Review Board.

The following are requirements for all plats (detailed requirements for specific types of plats are given in subsequent subsections):

#### **Part. 5-1(A) Nature and Purpose of Plat**

This should be in the form of a brief statement placed in the upper right hand corner on each plat sheet. Examples of appropriate statements are:

1. Subdivision plat for ...
2. Replat of ... (lands being replatted) ... to ... (new name)
3. Amended plat of ...
4. Plat for abbreviated procedure of ...
5. Annexation plat of ...

### **Part. 5-1(B) Title of Plat**

The name of the subdivision or parcel(s) created by the plat should be placed near the upper right hand corner of each plat sheet immediately below the nature and purpose statement and should be the boldest lettering on the sheet.

### **Part. 5-1(C) Date of Plat**

The month and year in which the plat is prepared should be placed immediately below the title of the plat on each sheet.

### **Part. 5-1(D) Location Map / Zone Atlas Map Number**

A reduced scale map showing the relationship of the lands of the plat to principal landmarks and municipal boundaries should be placed in the upper left hand corner of the plat sheet or “first sheet” if a multiple sheet plat. The identification of the Albuquerque Zone Atlas map within which the plat lies must be shown, preferably immediately below or above the location map.

### **Part. 5-1(E) Scale and North Arrow**

Drawing scale must be shown as both equivalent scale and graphic scale, preferably immediately below the north arrow which must be shown in proper orientation with respect to the plat lines on each plat sheet. A north arrow must also be provided to orient the location map.

### **Part. 5-1(F) Plat Boundary Lines**

Plat boundary lines must be shown as the boldest lines on the plat sheet and must be properly oriented and annotated giving the bearings of all lines in degrees, minutes, and seconds and the basis for such bearings. The distances of all lines must be drawn to correct scale and dimensioned in feet correct to hundredths or other functional reference system.

### **Part. 5-1(G) Tie to Permanent Survey Monuments**

Tie to Permanent Survey Monuments from the plat boundary lines must be shown giving monument identification, New Mexico State Plane Coordinates, if applicable, and bearings and distances of courses establishing ties; bearings in degrees, minutes and seconds, and distances in feet and hundredths. (See [Chapter 10, Surveys and Monumentation](#), for detailed information.)

### **Part. 5-1(H) Existing Easements**

Existing easements within, along, or intersecting the plat boundaries must be shown giving correct location, dimensions, and purpose or nature of right of easement. Existing easements which are to remain in the Final Plat should be drawn in light lines or dashed lines and clearly labeled. Easements intended to be abandoned or vacated by Final Plat approval should be shown as ghost lines, easily distinguished from lines for easements to remain, and must be clearly labeled including the intent to abandon or vacate. Vacation of easements will require additional documentation (see [Article 5-3](#) of this chapter).

### **Part. 5-1(I) Existing Public Right-of-Way**

Existing public right-of-way along or intersecting the plat boundary or boundary streets of the plat must be shown giving correct locations and dimensions, purpose or nature, and name, if applicable.

### **Part. 5-1(J) Total Area of Plat**

Total area of plat within the plat boundaries must be shown in acres, rounded as specified for the type of plat being prepared.

### **Part. 5-1(K) Monument Description and Location**

Monument description and location must be shown for all found monuments and for all monuments set or, if a Preliminary Plat, intended to be set within or related to the plat boundary and ties thereto. Monument description must include the registration number of the surveyor who set the monument or the number which appears on found monuments.

### **Part. 5-1(L) Special Flood Hazard Areas**

Flood Hazard Areas shall be shown on the plat and a note shall be added to the plan indicating the Flood Insurance Rate Map number and effective date.

## **ARTICLE 5-2 PRELIMINARY PLAT REQUIREMENTS**

The following requirements for Preliminary Plats are in addition to the general requirements for all plats:

### **Part. 5-2(A) Scale**

1. Must be 1 in. to 100 ft. (1":100') or 1 in. to 50 ft. (1":50') if determined to be appropriate by the DRB.

### **Part. 5-2(B) Proposed Monumentation**

1. Proposed bench mark locations.
2. Proposed Permanent Survey Monument(s) location and method of tie to plat boundary.
3. Proposed subdivision control monuments location and type.

### **Part. 5-2(C) Existing Conditions**

1. Type and width of paving on existing streets intersecting, along, or within 150' of the plat boundary including curb, gutter and sidewalk locations.
2. Existing utilities within and adjacent to plat
  - a. Location and size of:
    - i water wells
    - ii water reservoirs
    - iii water lines
    - iv sanitary sewers
    - v storm drains, channels and other facilities
  - b. Location of:
    - i gas lines
    - ii fire hydrants
    - iii power lines and poles
    - iv telephone lines and poles
    - v street lights
    - vi any other facilities in the right-of-way.
  - c. If not on or immediately adjacent to site, direction to, distance to, and size of:
    - i nearest water lines
    - ii nearest sanitary sewers with invert elevation
3. Ground elevation and site based on mean sea level as established within [Chapter 10, Surveys and Monumentation](#).
  - a. For land having slopes less than 1%
    - i by contour lines at intervals of not more than 1ft. and spot elevations not more than 100 ft. apart at selected locations sufficient to define all breaks in grade and drainage features
  - b. For lands sloping between 1% and 5%
    - i contour lines at intervals not to exceed 2 ft.
  - c. For lands sloping more than 5%
    - i by contour lines at intervals not to exceed 5 ft.
4. Existing property lines to be eliminated
  - a. by light dashed lines clearly annotated to indicate elimination intent

## **Part. 5-2(D) Proposal Elements**

1. Plat boundary gross area in acres to the nearest tenth of an acre.
2. Proposed public right-of-way locations and widths, street widths, street names, and sidewalk locations and widths.
3. Proposed private way locations and widths, street names and widths, and sidewalk locations and widths.
4. Proposed easements of any nature, locations, dimensions, nature or purpose, ownership and any limitations thereto.
5. Proposed block and lot lines with number or letter identification of each block and lot to be created. Lot fronts must be designated on any double fronting residential lots.
6. Proposed ground elevations presented as specified in [Part. 5-2\(C\)](#).
7. Proposed locations of any planned water wells, reservoirs.
8. Any significant topographic features or conditions on-site.
9. Zoning of and adjacent to the site

## **ARTICLE 5-3 FINAL PLAT DETAILED REQUIREMENTS**

The following detailed requirements for Final Plats are in addition to the general requirements for all plats given in [Article 5-1](#).

### **Part. 5-3(A) Scale**

Must be either 1" to 100', or 1" to 50' (1" to 50' preferable, when practical).

### **Part. 5-3(B) Monuments**

All monumentation shall conform to the requirements specified in the Minimum Standards for Surveying in New Mexico, Title 12, Chapter 8, Part 2, NMAC, 17 D through F and shall be set by a New Mexico licensed surveyor or under his/her direct responsible charge.

#### **Section. 5-3(B)(1) Subdivision Control Monuments**

##### **5-3(B)(1)(i) X Exterior Monumentation**

All angle points, points of curvature, and points of tangent along the subdivision perimeter shall be monumented as exterior subdivision control monuments before the City Surveyor signs the final plat.

##### **5-3(B)(1)(ii) X Interior Monumentation**

1. Interim monuments may be required as specified in the Minimum Standards for Surveying in New Mexico 12.8.2.17 D.

2. Permanent. Before city acceptance of subdivision street improvements, permanent interior subdivision control monuments shall be installed.

### **Section. 5-3(B)(2) Permanent Survey Monuments**

All subdivision perimeters shall be referenced by bearing and distance to a minimum of one permanent survey monument approved by the City Surveyor. Two permanent survey monuments shall be referenced for each major subdivision by bearings and distances to at least two points on the subdivision perimeter. The permanent survey monument shall be identified on the plat by reference to AGRS published data, including name, northing, easting, ground to grid factor, convergence angle, New Mexico Coordinate System zone and reference datum.

### **Section. 5-3(B)(3) Bench Marks**

The location, description, elevation based on mean sea level datum per Chapter 10, Surveys and Monumentation and the registration number of the surveyor who set it must be shown on the plat for each bench mark required to be set or used for vertical control in the subdivision. The elevations to be shown for bench marks on the plat must be as approved by the Chief City Surveyor, according to the procedures given in [Chapter 10, Surveys and Monumentation](#).

### **Section. 5-3(B)(4) Existing Monumentation**

All existing monumentation, including found property corners, must be shown on the plat, giving accurate description, location and registration number of surveyor who set the monument, if available.

## **Part. 5-3(C) Plat Boundary**

In addition to the boundary items required by [Section 5.3.6](#), both record and measured distances and bearings must be shown and identified for all courses in the plat boundary on Final Plats.

## **Part. 5-3(D) Plat Area**

The total gross area in acreage or square feet expressed to four decimal places within the plat boundary must be shown on the Final Plat located on the plat as specified in the [Part. 5-1\(F\)](#).

## **Part. 5-3(E) Reference to Federal Rectangular System**

Final Plats must be referenced to the Federal Rectangular System, often referred to as the "sectionalized system," by giving the location of the platted area within the appropriate section, township, range and, if applicable, fraction or aliquot part of a section. If the plat does not lie within an officially sectionalized area, the reference may be given to a projection of the official system and identified

as projected. The description of location should also include the New Mexico Principal Meridian. When projected location descriptions are used and when projection is impractical, the name of the land grant or other body of unsectionalized land in which the plat lies must be identified. The reference to the Federal Rectangular System and, if applicable, the name of the unsectionalized land is to be located on the plat immediately under the title of the plat.

## **Part. 5-3(F) Interior Data**

The following additional data must be shown within the plat boundary of all Final Plats.

1. All existing public rights-of-ways which will remain and those to be created by the plat. Required information includes the following:
  - a. *Names of streets*
  - b. *Right-of-way widths and locations*
  - c. *Right-of-way data including the length, central angle, and radius of all curves in right-of-way lines*
  - d. *Centerline data including the length, central angle, and radius of all curves*
2. All easements, both existing and those to be created by the plat giving the following information:
  - a. *Location and dimensions by bearing and distance;*
  - b. *Purpose; and*
  - c. *Limitations, if any*
3. Any easements intended to be abandoned, identified as “to be abandoned or vacated by this plat”<sup>1</sup>
4. All block and lot lines giving the following information:
  - a. *Location and dimensions of all lot lines by bearing and distance;*
  - b. *Areas of all lots/tracts (gross and net) in acreage or square feet;*
  - c. *Number or letter identification, in progression, for each lot and each block. No lot identification may be duplicated within a single block and no block identification may be duplicated within a plat boundary; and*
  - d. *Lot fronts must be designated for all single-family residential lots abutting more than one street.*
5. Any lots dedicated or reserved for public use must be identified giving location and dimensions by bearing and distance, area in acres or square feet, and the intended purposes. If dedicated by a separate instrument, the document identification and County Clerk recordation information is to be included.

## **Part. 5-3(G) Exterior Data**

The following information concerning elements exterior to the plat boundary must be shown on the Final Plat:

1. Identification of lands adjoining the platted land, giving the identity of recorded subdivision plats, including the County Clerk recordation information, and for other parcels of land, the most appropriate and accurate identification available.

---

<sup>1</sup> *Easements may only be vacated by this means if legal consent of all those holding legal interest in the easement is provided on the Final Plat. If vacated by separate procedure or instrument, the approved document must be identified by title and county clerk recordation identification.*



2. All streets on adjacent lands which intersect the boundary or boundary streets of the plat must be shown giving the location, dimensions of right-of-way and name. Private ways which intersect the plat boundary or boundary streets must be shown similarly.

### **Part. 5-3(H) Subdivision Data**

The following additional general information must be shown on the Final Plat:

1. The total miles of full-width streets and the total miles of half-width streets, as well as the total miles of all streets created by the plat;
2. The total area of right-of-way dedicated
3. The total number of lots and or tracts created by the plat;
4. The case number of the plat as assigned by the City/County Planning Authority; and
5. The date, including at least the month and year, of the survey.

### **Part. 5-3(I) Metes and Bounds Description / Legal Description**

A metes and bounds description, of the exterior boundary of the platted land must be given on the Final Plat, or the caption portion of the description may include reference to the most recent recorded identification of the lands being subdivided or platted and the county recordation information therein. The description is to be located within the central one third of the area of the first sheet of the Final Plat, beginning near the upper margin.

### **Part. 5-3(J) Consent and Dedication Statements**

1. A statement or statements must be on the Final Plat clearly stating that the proposed plat represents the desires of the owners and that all dedications, grants of easements and other public features of the plat are given for public use in perpetuity with the knowledge and free consent of the owners. Separate clauses of such statements may be necessary for specific special purpose features such as drainage easements. Unless otherwise approved by the planning authority, all grants of easements to the City must generally allow use for other purposes (e.g., drainage easements must also allow for installation of underground sanitary sewer and water lines).
2. All lands dedicated for public rights-of-way are to be dedicated in fee simple and the dedication statement must so state.
3. If lands are to be dedicated as parks within or associated with the plat, a separate deed for the dedicated land is required. The dedicated park land must be clearly indicated on the plat, as described herein for public areas, and the county recordation information of the deed for the land must be shown on the plat.
4. If the plat includes any private ways, there must be a statement on the plat establishing the permanent legal character of such private ways, and the statement must be acknowledged by the owners. The statement must

indicate the permanent owners of the rights granted in the private ways. A typical form of such statement might read:

Private ways (streets) shown hereon are hereby granted as permanent access easements to be indivisibly and privately and collectively owned by the owners of the individual properties which the easements serve.

Similar statements must be provided if other ownerships are intended; however, the permanence of access rights to individual properties must be indicated.

If any private way on the plat serves more than one (1) lot and is not to be paved prior to request for plat approval, a bond assuring required paving must be posted with the City. A statement must be placed on the plat indicating the private ways which are covered by such bond, the date by which such paving is required to be installed, and the county recordation information for the documentation of the agreement under which the bond is established.

5. All easements must include beneficiary and maintenance responsibility.
6. All owners' signatures on the plat must be acknowledged in the manner required for acknowledgment of deeds.

## **Part. 5-3(K) Certifications**

The following certifications are required to be on the Final Plat:

1. Certification by the registered land surveyor who performed the surveys for the plat and who prepared the plat certifying the accuracy of the surveys and the plat and that the surveys were either performed by the surveyor or under his supervision and that the plat was prepared by the surveyor or under his supervision. If the plat is prepared from record documents only, the certification should so state.<sup>2</sup>
2. Certification by franchised utilities that respective needs, if reasonable, are met by the plat.
3. Certification by the Water Utility Authority that its requirements have been met.
4. Certification by the Albuquerque Metropolitan Arroyo Flood Control Authority (AMAFCA) that its needs have been met. For lands lying within the City limits of Albuquerque, this certification may be made by the AMAFCA designee on the City Engineer's staff.<sup>3</sup>
5. Either the AMAFCA Executive Engineer or the City Engineer can provide more detailed limits for questionable cases.
6. Certification by the Park Planner that park requirements have been met.
7. Certification by the City Land Surveyor that required monumentation is in place or that satisfactory arrangements for deferred monumentation have

<sup>2</sup> *Plats which do not contain clearly identified ties to permanent survey monuments either by record or existing found monuments will not be accepted.*

<sup>3</sup> *The requirement for AMAFCA approval generally applies only to plats lying east of the north and south diversion channels constructed under AMAFCA auspices and west of the Middle Rio Grande Conservancy District channels on the west side of the Rio Grande.*

- been made, including financial security and that surveys have been found in compliance with design standards.
8. Certification by the City Engineer that water courses, storm drainage provisions, and street names are approved. <sup>4</sup>
  9. Certification by the Property Manager that requirements have been met for change in City of Albuquerque ownership or rights, involving any rights-of-way, grants of easement, or public lands to be altered by the plat
  10. Certification of approval by the Traffic Engineer of street, alley, and sidewalk configuration, right-of-way width, street width, and any private ways.
  11. Certification by the Planning Director of plat approval and of conditional acceptance of all dedications and grants of easement for public use. This certification must be accompanied by a statement on the plat indicating such approval and acceptance. An acceptable form of such statement is shown in subsection 7 of this chapter.
  12. Related certifications may be required in special circumstances as determined by the Development Review Board (DRB) or Environmental Planning Commission (EPC).
  13. If lot lines are changed from existing locations and public infrastructure such as water systems, and sanitary sewer systems are in place prior to the proposed platting, the owners of the lands being replatted or seeking such lot line change must certify acceptance of responsibility for any necessary relocation of water or sanitary sewer services to the lots affected by the lot line change.
  14. Certification by Albuquerque Geographic Information System (AGIS Division in Planning) of approval of digital plat submittal. Digital plat submittals must contain a minimum of the following:
    - a. Data shall be in NAD83 New Mexico State Plan Grid Coordinates or Ground coordinates tied to ACS (Albuquerque Control Survey network) monumentation.
    - b. The submittal shall disclose the coordinate system.
    - c. The content of the digital submittal shall include
      - i A single drawing in model space showing only parcel lines and easement lines.
      - ii Only Final Plat data will be provided.
      - iii Parcel lines shall be in one separate layer.
      - iv Access easement lines and all other easements that are 20 feet wide or greater shall be in a second separate layer.
      - v All other easements shall be in a third separate layer.
    - d. The digital plat submittal shall be accepted in the following formats:
      - i DXF (Drawing Interchange Format in ASCII (American Standard Code for Information Interchange) format.
      - ii Other formats directly compatible with ArcGIS Software (shapefiles or feature class within a file geodatabase) that have attributes defining which features are parcel lines, access easements, or other easements 20 feet wide or greater, and all other easements.
    - e. A PDF (Portable Document Format) or hard copy of all pages of the plat shall accompany the electronic digital plat submittal.
    - f. Files may be transmitted as attachments to e-mail directly to AGIS division staff or brought into the AGIS Division offices with the current acceptable media (disc or USB flash drive).

---

<sup>4</sup> Street names must not contain more than 17 letters and spaces. In order to assure that street names will receive approval, the City Surveyor's office should be contacted to review proposed names for possible conflicts with existing street names.

- g. The assigned Planning Department project number shall be clearly communicated and file names shall follow this standard naming convention <DRB Project#>.file extension (.dxf, .pdf).
- h. The digital plat submittal shall be validated by AGIS as a condition to final sign-off and the validation review will be performed in a timely manner. Upon approval, AGIS staff will notify the applicant and the DRB chair via email.

## ARTICLE 5-4 GRANT OF DRAINAGE EASEMENT

Whenever storm water runoff is directed from a public Right-of-Way or Easement into private property the drainage improvements or natural drainage conveyance system must be contained in a Public Drainage easement whether it is maintained by the private property owner or by the public.

The easement must conform to the requirements of [Article 6-13 Drainage Right-of-Way and Easements](#), and the language in the granting document must conform to standards established by the City Engineer and City Legal Staff. Following are three links to standard language for drainage easements:

1. [Drainage Facilities and/or Detention Areas Maintained by Lot Owner on a Plat](#)
2. [Dedication of Drainage Easements: City Constructs and Maintains on a Plat](#)
3. [Dedication of Drainage Easements: City Constructs and Maintains as a separate instrument](#)

## ARTICLE 5-5 DRAINAGE COVENANTS

Nearly all new developments include drainage improvements that are required by the [Code of Ordinances, Chapter 14 - Zoning, Planning and Building, Article 5-Flood Hazard and Drainage Control](#). In those instances where such drainage features must be perpetually maintained to minimize possible damage to other properties or to public properties, the City may require the developer enter into a covenant assuring maintenance of such facilities. There are three (3) types of covenants which are discussed below.

Covenants run with the land. They generally require the owner of the land to maintain features to City standards and allow the City's entrance upon the property to inspect drainage features for such maintenance as needed. The following is a brief description of the three types of drainage covenants the City may require the developer to enter into:

1. **Private Facility Drainage Covenant** - for a privately owned, privately maintained facility, places maintenance and inspection responsibility on the property owner(s). For example, a cutoff wall to protect property adjacent to an unlined arroyo or a first flush pond.
2. **Drainage Covenant (no public easement)** - for a privately owned, privately maintained facility whose non-function or failure to perform, will cause damage to others. For example, a large detention pond in a shopping center. The maintenance responsibilities lie with the owner. The

City, however, has the right to inspect periodically and to enforce proper maintenance.

3. **Agreement and Covenant** - for a privately maintained facility which is within the City's property (City right-of-way or City easement). The City has the right to inspect and to enforce proper maintenance. If the City right-of-way or City Easement does not already exist before the development then one must be dedicated and/or granted in accordance with the "Final Plat" or "Grant of Drainage Easement" Procedures above. For example, an agreement and Covenant may be required for phased developments that require temporary retention ponds and/or sediment ponds.

## **ARTICLE 5-6 GRAPHIC STANDARDS**

### **Part. 5-6(A) Materials**

1. Preliminary Plats must be drawn on stable reproducible material.
2. Final Plats must be drawn in permanent black ink on stable reproducible, material or produced by other means resulting in a permanent, stable, and reproducible. All signatures must be original; not reproduced. Plat sheet size for single sheet plats shall be 18" x 24".
3. Spliced plat sheets are not acceptable.
4. Adhesive materials may not be used for line work or dimensions and bearings of lines on Final Plats. Stable adhesive materials containing typed data, legends, location maps, north arrows, logos and standard signature/certifications may be used provided that the adhesive material is permanent and fully reproducible. Signatures must be original. Plats assembled with adhesive materials that are not firmly adhered to the plat base sheet will not be considered acceptable. Permanent, stable, reproducible copies of plats assembled with adhesive materials may be accepted provided all signatures on the copy are original.

### **Part. 5-6(B) Drafting Standards**

#### Chapter 4

Construction Plan Standards provides the minimum standards required to achieve satisfactory plat submittals All plats shall comply with the standards outlined in Chapter 4.

## **ARTICLE 5-7 ACCEPTABLE FORMS OF LANGUAGE**

The following are examples of acceptable forms of language for generally required plat elements. The persons preparing the plat and those who are signatory to any aspect of the plat are cautioned that it is their responsibility to assure that the statements they make or certify to on the plat express clearly their desired intent, and that they have the legal right and authority to certify, consent, or dedicate as their signature indicates.

### **Section. 5-7(B)(1) Free Consent and Dedication**

The subdivision hereon described is with the free consent and in accordance with the desires of the undersigned owner(s) and/or proprietor(s) thereof and said owner(s) and/or proprietor(s) do hereby dedicate all streets and public right-of-way shown hereon to the City of Albuquerque (or county of Bernalillo) in fee simple with warranty covenants and do hereby grant all utility easements shown hereon to the public use forever including the rights of ingress and egress (both surface and subsurface). The undersigned owner(s) and/or proprietor(s) also grant to the City of Albuquerque in perpetuity all sanitary sewer, water line, and drainage easements shown hereon including the right to construct, operate, inspect, and maintain sanitary sewers, water lines, and drainage facilities therein. Unless specifically limited elsewhere on this plat, all easements granted to the City of Albuquerque may be used for any or all of the purposes of sanitary sewer, water line, or drainage facility even though only one of these purposes is stated on the easement as drawn on the plat.<sup>5</sup>

The undersigned owner(s) and/or proprietor(s) do hereby freely consent to all the foregoing and do hereby represent that I/we am/are authorized to so act.

Owner/Proprietor name typed or printed

\_\_\_\_\_  
Owner/Proprietor's Signature

\_\_\_\_\_  
Date

If there are other holders of equitable interest in the property being platted or subdivided, the following statement should be added to the consent and dedication material:<sup>6</sup>

<sup>5</sup> Any special easements, private ways, reverter clauses, or other qualifying statements should be inserted in the body of this declaration prior to the concluding statement and signatures. If park land is dedicated, a separate deed is also needed and the county recordation information of such deed should be referenced. If cash in lieu of dedication is provided, the fact must be noted on the plat.

<sup>6</sup> Each owner/proprietor's or interest holder's signature must be acknowledged as required for a deed (i.e., notarized). If the owner(s)/proprietor(s) is a corporation, the signatory on behalf of such corporation must be empowered to bind the corporation in this manner and the signatory's office in the corporation must be shown.

### Section. 5-7(B)(2) Surveyor's Certification<sup>7</sup>

I, \_\_\_\_\_, a registered professional land surveyor under the laws of the State of New Mexico, do hereby certify that this plat was prepared by me or under my supervision, and meets the minimum requirements of monumentation and surveys of the Albuquerque Subdivision of Land Regulations, and that it is true and correct to the best of my knowledge and belief.

\_\_\_\_\_  
John Q. Surveyor  
PLS No. 0000  
New Mexico

\_\_\_\_\_  
Date

### Section. 5-7(B)(3) Sample Signature Block for Plats

**PROJECT NUMBER:** \_\_\_\_\_

Application Number: \_\_\_\_\_

**PLAT APPROVAL**  
*UTILITY APPROVALS:*

\_\_\_\_\_  
PNM Electric Services  
Date

\_\_\_\_\_  
New Mexico Gas Company  
Date

\_\_\_\_\_  
Century Link  
Date

\_\_\_\_\_  
Comcast  
Date

*CITY APPROVALS:*

\_\_\_\_\_  
City Surveyor  
Date

\_\_\_\_\_  
Real Property Division<sup>8(conditional)</sup>  
Date

\_\_\_\_\_  
Environmental Health Department<sup>9(conditional)</sup>  
Date

<sup>7</sup> Title reports, when used, must be current as of the dates of the plat.

<sup>8</sup> CONDITIONAL (include signature line when applicable) - If there is a vacation involved with the plat.

<sup>9</sup> CONDITIONAL (include signature line when applicable) - if the plat involves any known or existing landfill issues



_____ Traffic Engineering, Transportation Division	_____ Date
_____ ABCWUA	_____ Date
_____ Parks and Recreation Department	_____ Date
_____ AMAFCA	_____ Date
_____ City Engineer	_____ Date
_____ DRB Chairperson, Planning Department	_____ Date
_____ City Zoning, Planning Department	_____ Date

# CHAPTER 6

## DRAINAGE, FLOOD CONTROL AND EROSION CONTROL

This chapter presents the standards established for Drainage, Flood Control and Erosion Control within the City of Albuquerque. Detailed requirements to facilitate the planning, design, construction, and operation of both public and private drainage control, flood control, stormwater quality, and erosion control facilities are covered as follows:

### ARTICLE 6-1 CONTENTS

#### ARTICLE 6-1 GOVERNING REGULATIONS ..... 170

#### ARTICLE 6-2 HYDROLOGY..... 171

Part. 6-2(A) Procedure for 40 Acre and Smaller Basins .....	171
Section. 6-2(A)(1) Precipitation Zones .....	171
Section. 6-2(A)(2) Land Treatments .....	175
Section. 6-2(A)(3) Abstractions .....	176
Section. 6-2(A)(4) Excess Precipitation & Volumetric Runoff .....	176
Section. 6-2(A)(5) Peak Discharge Rate for Small Watersheds.....	179
Section. 6-2(A)(6) Use of Rational Method for Watersheds Larger than 40 Acres	180
Section. 6-2(A)(7) Hydrograph for Small Watershed .....	182
Part. 6-2(B) Time of Concentration, Lag Time, and Time to Peak.....	182
Section. 6-2(B)(1) Definitions .....	183
Section. 6-2(B)(2) Computation of Time of Concentration .....	183
Section. 6-2(B)(3) Computation of NRCS Lag Time.....	185
Section. 6-2(B)(4) Computation of Time to Peak .....	185
Section. 6-2(B)(5) Time of Concentration for Steep Slopes and Natural Channels	187
Section. 6-2(B)(6) Channel Routing for Steep Slopes and Natural Channels ....	189
Part. 6-2(C) Procedure for Small and Large Watersheds.....	190
Section. 6-2(C)(1) Computer Program.....	190
Section. 6-2(C)(2) Zones .....	190
Section. 6-2(C)(3) Design Storm.....	190
Part. 6-2(D) Symbols and Bibliography.....	191
Section. 6-2(D)(1) Definitions of Symbols.....	191
Section. 6-2(D)(2) Bibliography.....	193

#### ARTICLE 6-3 SITE DEVELOPMENT..... 196

#### ARTICLE 6-4 GRADING AND EROSION CRITERIA ..... 196

Part. 6-4(A) Slope Criteria .....	196
Part. 6-4(B) Grading near the Property Line .....	196
Part. 6-4(C) Grading In and Adjacent to Major Facilities .....	196
Part. 6-4(D) Grading In and Adjacent to Major Public Open Space.....	197
Part. 6-4(E) Means of Erosion Control.....	197
Part. 6-4(F) Levees and Berms .....	198

Section. 6-4(F)(1) Definitions.....198  
 Section. 6-4(F)(2) Design Criteria.....198  
 Section. 6-4(F)(3) Earthwork for Berms.....199  
 Section. 6-4(F)(4) Certification .....199

**ARTICLE 6-5 VALLEY DRAINAGE CRITERIA ..... 199**

Part. 6-5(A) Single Lot Residential Development and Additions..... 199  
 Part. 6-5(B) Residential Subdivisions ..... 199  
 Part. 6-5(C) Non-Single Family Residential Development and Commercial  
 Properties ..... 200  
 Part. 6-5(D) Flat Grading Scheme for Residential Subdivisions ..... 200

**ARTICLE 6-6 DEVELOPING IN OR ADJACENT TO A FLOOD ZONE.... 201**

Part. 6-6(A) Grading ..... 201  
 Part. 6-6(B) Compensatory Volume..... 201  
 Part. 6-6(C) AO Zone ..... 201  
     Section. 6-6(C)(1) Determination of Base Flood Elevation (BFE) in an AO Zone  
     201  
 Part. 6-6(D) A Zone ..... 202  
 Part. 6-6(E) Floodplain Development Permit..... 202  
 Part. 6-6(F) Letters of Map Change (LOMC)..... 202  
 Part. 6-6(G) Project Requirements..... 202

**ARTICLE 6-7 DOWNSTREAM CAPACITY AND OFFSITE FLOWS..... 203**

Part. 6-7(A) Downstream Capacity ..... 203  
 Part. 6-7(B) Offsite Flows ..... 203  
 Part. 6-7(C) Historic Flow Path through Adjacent Private Property ..... 203

**ARTICLE 6-8 ENGINEERED CHANNELS AND NATURAL ARROYOS.. 204**

Part. 6-8(A) General Hydraulic Criteria..... 204  
 Part. 6-8(B) Sharp Curves ..... 204  
 Part. 6-8(C) Maximum Froude Number ..... 204  
 Part. 6-8(D) Water Surface Profile Calculations..... 204  
     Section. 6-8(D)(1) Determination of Controlling Water Surface Elevation .....205  
     Section. 6-8(D)(2) Direction of Calculation .....205  
     Section. 6-8(D)(3) Head Losses .....205  
     Section. 6-8(D)(4) Channel Inlets .....206  
     Section. 6-8(D)(5) Bank Protection .....209  
     Section. 6-8(D)(6) Piers .....209  
     Section. 6-8(D)(7) Curving Alignments .....209  
     Section. 6-8(D)(8) Freeboard .....211  
 Part. 6-8(E) Channel Design Criteria ..... 212  
     Section. 6-8(E)(1) Unlined Channels .....212  
     Section. 6-8(E)(2) Composite Linings .....213  
     Section. 6-8(E)(3) Maximum Sidewall Slopes .....213  
     Section. 6-8(E)(4) Channel Maintenance and Access Road .....213  
     Section. 6-8(E)(5) Channel Access Ramps .....213  
     Section. 6-8(E)(6) Street Crossings .....214  
     Section. 6-8(E)(7) Subdrainage .....214  
     Section. 6-8(E)(8) Channel bed width.....214  
 Part. 6-8(F) Miscellaneous Hydraulic Calculations..... 214  
     Section. 6-8(F)(1) Hydraulic Jump .....214  
     Section. 6-8(F)(2) Trash Rack Head Loss.....215

Section. 6-8(F)(3) Side Channel Weirs.....216  
 Part. 6-8(G) Channel Treatment Selection Guidelines ..... 216  
     Section. 6-8(G)(1) General .....216  
     Section. 6-8(G)(2) Flood Control .....217  
     Section. 6-8(G)(3) Drainage.....217  
     Section. 6-8(G)(4) Maintenance.....217  
     Section. 6-8(G)(5) Rights-of-Way and Easements .....217  
     Section. 6-8(G)(6) Safety and Fence Requirements.....217  
     Section. 6-8(G)(7) Upstream and Downstream Channel Treatments .....217  
     Section. 6-8(G)(8) Initial Cost and Life Expectancy .....218  
     Section. 6-8(G)(9) Joint Use Possibilities .....218  
     Section. 6-8(G)(10) Sediment Transport and Channel Stability.....218  
     Section. 6-8(G)(11) Channel Stability .....218  
     Section. 6-8(G)(12) Channel Construction Details.....219

**ARTICLE 6-9 STREET HYDRAULICS ..... 221**

Part. 6-9(A) Street Hydraulic Design Criteria..... 221  
 Part. 6-9(B) Option to Drain the Street to the Median ..... 221  
 Part. 6-9(C) Effects of Hydraulic Jump or Superelevation..... 222  
 Part. 6-9(D) Intersection ..... 222  
 Part. 6-9(E) Drainage Design Criteria in Street Design..... 222  
 Part. 6-9(F) Inlet Placement and Design Criteria..... 223  
     Section. 6-9(F)(1) Standard Inlets .....223  
     Section. 6-9(F)(2) Cattle-Guard and Median inlets.....228  
     Section. 6-9(F)(3) Publicly-Maintained Inlets To Be Located Within Street Rights-of-Way.....228  
     Section. 6-9(F)(4) Inlets in a Sump Condition.....229  
 Part. 6-9(G) Inlet Lateral and Connector Pipe Capacity ..... 229  
     Section. 6-9(G)(1) Connector and Lateral Pipe Criteria.....230  
     Section. 6-9(G)(2) Consideration of Existing Drainage Systems During Construction  
     230

**ARTICLE 6-10 CRITERIA FOR HYDRAULIC DESIGN OF CLOSED CONDUITS ..... 231**

Part. 6-10(A) General Hydraulic Criteria..... 231  
 Part. 6-10(B) Hydraulic Grade Line Calculations ..... 231  
     Section. 6-10(B)(1) Determination of Control Water Surface Elevation .....231  
 Part. 6-10(C) Instructions for Hydraulic Calculations ..... 232  
     Section. 6-10(C)(1) Head Losses .....233  
 Part. 6-10(D) Design Requirements for Maintenance and Access ..... 235  
     Section. 6-10(D)(1) Manholes .....235  
     Section. 6-10(D)(2) Pressure Manholes .....236  
     Section. 6-10(D)(3) Special Manholes .....236  
     Section. 6-10(D)(4) Deep Manholes .....236  
     Section. 6-10(D)(5) Bends .....236  
     Section. 6-10(D)(6) Curvilinear Storm Drain.....236  
 Part. 6-10(E) Closed Conduit Pipe Size and Slope ..... 237  
     Section. 6-10(E)(1) Minimum Pipe Size .....237  
     Section. 6-10(E)(2) Minimum Slope .....237  
 Part. 6-10(F) Earthen Channels to Storm Drain Structures ..... 237  
 Part. 6-10(G) Storm Drain Outlets to Public Earthen Arroyos and Ponds.... 237

*Section. 6-10(G)(1) Incorporation of "Urban Storm Drainage Criteria Manual Volume 2" from the Urban Drainage and Flood Control District, Denver, Colorado*  
237

*Section. 6-10(G)(2) Private Storm Drain Outlets to Onsite Basins or Swales*.....253

Part. 6-10(H) Protection and Debris Barriers ..... 253

*Section. 6-10(H)(1) Protection Barriers* .....253

*Section. 6-10(H)(2) Debris Barriers* .....254

*Section. 6-10(H)(3) Debris Basins* .....254

Part. 6-10(I) Closed Conduit Angle of Confluence ..... 254

Part. 6-10(J) Flapgates ..... 255

Part. 6-10(K) Rubber-Gasketed Pipe ..... 255

Part. 6-10(L) Junctions into Existing Storm Drain Main Lines..... 255

Part. 6-10(M) Submittal Requirements..... 255

*Section. 6-10(M)(1) Hydraulic Model*.....255

*Section. 6-10(M)(2) Culverts* .....256

**ARTICLE 6-11 POND REQUIREMENTS ..... 256**

Part. 6-11(A) Design Requirements ..... 256

*Section. 6-11(A)(1) Detention Ponds* .....256

*Section. 6-11(A)(2) Retention Ponds* .....256

*Section. 6-11(A)(3) Surge Ponds*.....257

*Section. 6-11(A)(4) Stormwater Quality Ponds* .....257

Part. 6-11(B) Infiltration Rate ..... 257

Part. 6-11(C) Ponds in Parking Areas..... 258

Part. 6-11(D) Fencing Around Ponds ..... 258

Part. 6-11(E) Private Ponds to be Built to Public Pond Specifications..... 258

Part. 6-11(F) Rock Void Space for Pond Volume ..... 258

Part. 6-11(G) Privately Maintained Ponds with a Public Drainage Easement  
258

Part. 6-11(H) City Maintained Ponds ..... 259

*Section. 6-11(H)(1) Access* .....259

*Section. 6-11(H)(2) Spillways*.....259

*Section. 6-11(H)(3) Outlets*.....259

*Section. 6-11(H)(4) Pond Bottoms*.....259

*Section. 6-11(H)(5) Side Slope and Bottom Treatments* .....259

*Section. 6-11(H)(6) Minimum Pond Size* .....259

*Section. 6-11(H)(7) Fencing*.....260

Part. 6-11(I) Temporary Public Ponds ..... 260

Part. 6-11(J) Pond Evacuation Time..... 260

Part. 6-11(K) Infiltration System Design ..... 260

**ARTICLE 6-12 STORMWATER QUALITY AND LOW IMPACT DEVELOPMENT ..... 261**

Part. 6-12(A) Low Impact Development Strategies..... 262

Part. 6-12(B) Effective Strategies for Stormwater Treatment ..... 262

*Section. 6-12(B)(1) Landscape Category*.....263

*Section. 6-12(B)(2) Paving Category*.....265

*Section. 6-12(B)(3) Elevated Category*.....265

*Section. 6-12(B)(4) Streetscape Category*.....266

*Section. 6-12(B)(5) Flood Control Category*.....266

*Section. 6-12(B)(6) Offsite Mitigation Category*.....266

*Section. 6-12(B)(7) Payment-in-Lieu* .....266

Part. 6-12(C) Variance from On-site Stormwater Quality Volume Requirements  
267

    Section. 6-12(C)(1) Payment-in-Lieu .....268

    Section. 6-12(C)(2) Annual Adjustment of Fee .....268

    Section. 6-12(C)(3) Payment of Fee .....268

Part. 6-12(D) Land Uses that Require Additional Stormwater Controls ..... 271

    Section. 6-12(D)(1) Automotive Repair and Parts Shops .....271

    Section. 6-12(D)(2) Restaurants and Commercial Food Processing .....271

    Section. 6-12(D)(3) Gas Stations/Fueling Facilities .....271

Part. 6-12(E) Post-Construction Maintenance and Responsibilities ..... 271

    Section. 6-12(E)(1) City Post-Construction Inspections .....272

Part. 6-12(F) Construction Site Responsibility By Property Owner ..... 272

Part. 6-12(G) Construction Site Maintenance and Inspections ..... 273

**ARTICLE 6-13 DRAINAGE RIGHT-OF-WAY AND EASEMENTS ..... 284**

Part. 6-13(A) Rights-of-Way ..... 284

Part. 6-13(B) Easements ..... 284

Part. 6-13(C) Configuration ..... 284

    Section. 6-13(C)(1) Surface Facilities .....284

    Section. 6-13(C)(2) Public Underground Facilities .....284

Part. 6-13(D) Drainage Right-of-Way and Public Drainage Easement Access  
285

Part. 6-13(E) Private Storm Drain Improvements Within City Right-of-Way  
and/or Easements ..... 285

**ARTICLE 6-14 DRAINAGE AND STORMWATER QUALITY**

**SUBMITTALS ..... 286**

Part. 6-14(A) Introduction ..... 286

    Section. 6-14(A)(1) Drainage Report .....286

    Section. 6-14(A)(2) Conceptual Grading and Drainage Plan .....286

    Section. 6-14(A)(3) Grading and Drainage Plan .....286

    Section. 6-14(A)(4) Erosion and Sediment Control Plan .....286

    Section. 6-14(A)(5) LOMR, CLOMR and LOMR-F (LOMC) submittals .....286

    Section. 6-14(A)(6) Engineer's Certifications .....287

    Section. 6-14(A)(7) Pad Certification .....287

    Section. 6-14(A)(8) Drainage and Erosion and Sediment Control Submittals for  
Approval Sought .....287

Part. 6-14(B) Drainage Submittal Criteria ..... 288

    Section. 6-14(B)(1) Executive Summary .....289

    Section. 6-14(B)(2) Introduction .....289

    Section. 6-14(B)(3) Project Description .....290

    Section. 6-14(B)(4) Background Documents .....290

    Section. 6-14(B)(5) Existing Conditions .....290

    Section. 6-14(B)(6) Developed Conditions .....292

    Section. 6-14(B)(7) Grading Plan .....293

    Section. 6-14(B)(8) Calculations .....293

    Section. 6-14(B)(9) Conclusion .....293

Part. 6-14(C) Grading Plan Checklist ..... 293

    Section. 6-14(C)(1) General Information .....293

    Section. 6-14(C)(2) Existing Conditions .....294

    Section. 6-14(C)(3) Proposed Conditions .....295

Part. 6-14(D) Erosion and Sediment Control Plan Checklist ..... 296

Part. 6-14(E) Conceptual Grading and Drainage Plan Submittal Criteria ..... 297

Part. 6-14(F) Engineer's Certification for Non-Subdivisions ..... 297

Part. 6-14(G) Engineer's Certification for Subdivisions ..... 298  
 Part. 6-14(H) Required Certification Language ..... 299

**ARTICLE 6-15 MAINTENANCE AND POST-CONSTRUCTION RESPONSIBILITY ..... 300**

Part. 6-15(A) Fenced & Gated Public Facilities ..... 300  
 Part. 6-15(B) Drainage Maintenance Plan ..... 300  
     Section. 6-15(B)(1) Purpose ..... 300  
     Section. 6-15(B)(2) Plan Outline ..... 301  
 Part. 6-15(C) Drainage Maintenance Covenants ..... 301  
     Section. 6-15(C)(1) Applicability ..... 301  
     Section. 6-15(C)(2) Procedures for Covenants ..... 301  
     Section. 6-15(C)(3) Procedures for Plats ..... 302

**ARTICLE 6-16 COMMON EQUATIONS ..... 303**

Part. 6-16(A) Weirs ..... 303  
 Part. 6-16(B) Orifices ..... 303  
 Part. 6-16(C) Manning's Equation and Coefficient ..... 304

**ARTICLE 6-17 HISTORY ..... 305**

**ARTICLE 6-18 REFERENCE ..... 309**

Part. 6-18(A) Hydraulics ..... 309  
     Section. 6-18(A)(1) Weirs and Orifices ..... 309  
     Section. 6-18(A)(2) Closed Conduits ..... 309  
     Section. 6-18(A)(3) Channels ..... 309  
     Section. 6-18(A)(4) Catch Basins ..... 309  
     Section. 6-18(A)(5) Street Hydraulics ..... 310  
     Section. 6-18(A)(6) Berms and Levees ..... 310

**TABLES**

TABLE 6.3.1 Precipitation Zones ..... 172  
 TABLE 6.3.2 Participation for Zones 1-4 ..... 172  
 TABLE 6.3.3 Land Treatments ..... 175  
 TABLE 6.3.4 Percent Treatment D (Impervious) ..... 175  
 TABLE 6.3.5 Initial Abstraction ..... 176  
 TABLE 6.3.6 Infiltration (INF) ..... 176  
 TABLE 6.3.7 8 - 6 Hour Excess, 'E' ..... 177  
 TABLE 6.3.8 Peak Discharge ..... 179  
 TABLE 6.3.9 Coefficient C ..... 180  
 TABLE 6.3.10 Conveyance Factors ..... 184  
 TABLE 6.3.11 LAG EQUATION BASIN FACTORS ..... 185  
 TABLE 6.3.12 Definitions of Symbols ..... 191  
 TABLE 6.9.13 Maximum Sidewall Slopes ..... 213  
 TABLE 6.9.14 Channel Stability Changes ..... 219  
 TABLE 6.13.15 Development Types ..... 263  
 TABLE 6.13.16 Recommended Implementation Matrix ..... 267  
 TABLE 6.13.17 New Development ..... 269  
 TABLE 6.13.18 Redevelopment ..... 270  
 TABLE 6.15.19 Drainage Submittals for Approval Sought ..... 287  
 TABLE 6.17.20 Values of Manning's "n" ..... 304



## FIGURES

FIGURE 6.3.3	Precipitation Zones.....	172
FIGURE 6.3.4	Precipitation and Time .....	177
FIGURE 6.3.5	Time to Peak in Hours.....	182
FIGURE 6.3.6	Depth - Area Curves .....	191
FIGURE 6.5.7	Berm Cross Section .....	198
FIGURE 6.10.8	Grating Capacities for Type "A", "C", and "D".....	225
FIGURE 6.10.9	Grating Capacities for Type Double "C". "D", and "A".....	226
FIGURE 6.10.10	Grating Capacities for Type B.....	227
FIGURE 6.10.11	Optimum Spacing of Catch Basins on a Continuous Grade.....	228
FIGURE 6.11.12	Hydraulic Grade .....	232
<b>FIGURE 6.11.13</b>	<b>Need Title.....</b>	<b>234</b>
FIGURE 6.11.14	Junction Losses.....	234
FIGURE 6.11.15	General Design Dimensions for USBR Type VI Impact Sill Basin .....	239
FIGURE 6.11.16	Basin Width Diagram for USBR Type VI Impact Sill Basin .....	240
FIGURE 6.11.17	Modified Impact Sill Basin for Conduits 18" to 48" in Diameter.....	241
FIGURE 6.11.18	Impact Stiling Basin for Pipes Smaller than 18" in Diameter Upstream of Forebays.....	242
FIGURE 6.11.19	Baffle Chute Pipe Outlet.....	244
FIGURE 6.11.20	Grouted Boulder Rundown.....	246
FIGURE 6.11.21	Upstream and Downstream Views of a Low Tailwater Basin in Douglas County .....	247
FIGURE 6.11.22	Low Tailwater Riprap Basins for Storm Sewer Pipe Outlets (HS-19) .....	249
FIGURE 6.11.23	Concrete Flared End Section with Cutoff Wall for all Pipe Outlets .....	250
FIGURE 6.11.24	Low Tailwater Riprap Basins for Storm Sewer Pipe Outlets - Discharge and Flow Area Relationships for Circular and Rectangular Pipes.....	251
FIGURE 6.11.25	Low Tailwater Riprap Basins for Storm Sewer Pipe Outlets - Brink Depth Horizontal Pipe Outlet .....	251
FIGURE 6.11.26	Low Tailwater Riprap Basins for Storm Sewer Pipe Outlets - Riprap Selection Chart for Low Tailwater Basin at Pipe Outlet ....	252
FIGURE 6.11.27	Unprotected Culvert Outlets Cause Downstream Erosion .....	253
FIGURE 6.12.28	Peak Site Flow.....	257
FIGURE 6.13.29	Depressed Parking Island .....	263
FIGURE 6.13.30	Depressed Parking Island Diagram.....	264
FIGURE 6.13.31	Depressed Bioretention Areas.....	264
FIGURE 6.13.32	Landscape Conveyance-Bioswale.....	264
FIGURE 6.13.33	Porous Pavement with Typical Features .....	265
FIGURE 6.13.34	Planter Boxes Diagram .....	265
FIGURE 6.13.35	Swale Diagram .....	266
FIGURE 6.13.36	City of Albuquerque Annexation Boundary of 1950-1959.....	273
FIGURE 6.13.37	City of Albuquerque Annexation Boundary of 1950-1959 West Area .....	274
FIGURE 6.13.38	City of Albuquerque Annexation Boundary of 1950-1959 West 2 Area .....	274

FIGURE 6.13.39 City of Albuquerque Annexation Boundary of  
1950-1959 West 3 Area ..... 275  
FIGURE 6.13.40 City of Albuquerque Annexation Boundary of  
1950-1959 I40 Area..... 275

The standards, guidelines, and criteria presented herein are provided in order to facilitate the planning, design, construction, and operation of both public and private drainage control, flood control, stormwater quality, and erosion control facilities within the community.

The criteria are not intended as a substitute for good engineering judgment; imagination and ingenuity are encouraged. The thrust of these criteria is toward generalization in order to provide guidance for a large majority of design circumstances, but it must be understood that situations will arise in which these criteria are not appropriate.

The City Engineer or the AMAFCA Executive Engineer, as appropriate, may, in specific cases, require more stringent criteria or allow relaxation of these criteria based on their judgment and sound engineering practice.

The DRB representative from the City Engineer's office acts as the designee of the AMAFCA Executive Engineer except in review of proposals involving major arroyos or platting outside the City Limits where there is no immediately pending proposed annexation.

## **ARTICLE 6-2 GOVERNING REGULATIONS**

The planning, design, construction, and operation of both public and private drainage control, flood control, stormwater quality, and erosion control facilities must be prepared according to the ordinances and policies listed in the [\*Drainage, Flood Control and Erosion Control Governing Regulations Summary\*](#), found on the City of Albuquerque website. Some development plans will involve coordination with and approval by jurisdictions in addition to the City of Albuquerque, because the site drains to, or may impact, property in their jurisdiction, these agencies are also listed on the summary,

## ARTICLE 6-3 HYDROLOGY

AHYMO has been the primary method for hydrology calculations in Albuquerque since the DPM update in 1993, and it continues to be the basis for hydrology calculations. Other methods are allowed only if they agree closely with the AHYMO method. The “Procedures for 40 acres and Smaller Basins” is calibrated to exactly match AHYMO. In 1993, AHYMO replaced a rational method that had been derived from the SCS Curve Number method. One very specific version of the SCS Curve Number method is being allowed with this 2018 update because it agrees closely with AHYMO results.

The methods in the 1993 DPM were based on precipitation data from the NOAA Atlas 2 which has been superseded by NOAA Atlas 14. Atlas 14 Volume 1 Version 1 was published in 2001 Volume 4 in 2006 and the current Version 5 was published in 2011, and more revisions are expected as new data is collected. AHYMO- 93 and AHYMO-97 used the precipitation distributions from Atlas 2 and AHYMO- S4, released in 2009, uses precipitation distribution based on Atlas 14. The methods, graphs, and tables which follow will be used by the City of Albuquerque staff in the review and evaluation of development plans and drainage management plans.

Two basic methods of analysis are presented herein:

- [Part. 6-2\(A\)](#) - describes a simplified procedure for smaller watersheds based on the Rational Method and initial abstraction/uniform infiltration precipitation losses. The procedure is applicable to watersheds up to 40 acres in size, but the procedure may be extended to include larger watersheds with some limitations.
- [Part. 6-2\(C\)](#) - describes two unit hydro graph procedures which are accomplished using computer programs. One method is the AHYMO method and the other method is the SCS Curve Number method. The AHYMO-S4 program is used for the AHYMO method and TR-20 and HEC-HMS are two of the programs that can be used for the SCS CN method and the Atlas 14 precipitation distribution. These procedures are applicable for small and large watersheds.

[Part. 6-2\(B\)](#) describes the computation of time of concentration, lag time, and time to peak which are used in [Part. 6-2\(A\)](#) and [Part. 6-2\(C\)](#).

[Part. 6-2\(D\)](#) contains a tabulated list of definitions of symbols used in this Section of the D.P.M. and a bibliography.

### Part. 6-3(A) Procedure for 40 Acre and Smaller Basins

A simplified procedure for projects with sub-basins smaller than 40 acres has been developed based on initial abstraction/uniform infiltration precipitation losses and Rational Method procedures. For this procedure, Bernalillo County has been divided into four (4) Precipitation Zones.

#### Section. 6-3(A)(1) Precipitation Zones

Albuquerque’s four precipitation zones are indicated in [TABLE 6.2.1](#) and on [FIGURE 6.2.3](#), and the corresponding precipitation values are in Table A-2. When



**TABLE 6.3.2 Participation for Zones 1-4**

Partial Duration		500 year		100 year		10 year		2 year	
		Depth (in)	Intensity in/hr	Depth (in)	Intensity in/hr	Depth (in)	Intensity in/hr	Depth (in)	Intensity in/hr
<b>30</b>	min.	1.780	3.56	1.370	2.74	0.852	1.70	0.525	1.05
<b>60</b>	min.	2.200	2.20	1.690	1.69	1.060	1.06	0.650	0.65
<b>2</b>	min.	2.530	1.27	1.920	0.96	1.190	0.60	0.746	0.37
<b>3</b>	min.	2.760	0.92	2.000	0.67	1.250	0.42	0.800	0.27
<b>6</b>	min.	2.780	0.46	2.170	0.36	1.400	0.23	0.920	0.15
<b>24</b>	min.	3.090	0.13	2.490	0.10	1.680	0.07	1.160	0.05
<b>4</b>	day	3.780	0.04	3.120	0.03	2.190	0.02	1.560	0.02
<b>10</b>	day	4.680	0.02	3.900	0.02	2.760	0.01	1.970	0.01
<b>Zone 2</b>									
<b>5</b>	min.	0.731	8.77	0.565	6.78	0.355	4.26	0.220	2.64
<b>10</b>	min.	1.110	6.66	0.860	5.16	0.540	3.24	0.335	2.01
<b>12</b>	min.	-	6.20	-	4.81	-	3.01	-	1.87
<b>15</b>	min.	1.380	5.52	1.070	4.28	0.669	2.68	0.415	1.66
<b>30</b>	min.	1.860	3.72	1.440	2.88	0.901	1.80	0.559	1.12
<b>60</b>	min.	2.300	2.30	1.780	1.78	1.120	1.12	0.692	0.69
<b>2</b>	min.	2.660	1.33	2.030	1.02	1.260	0.63	0.797	0.40
<b>3</b>	min.	2.730	0.91	2.100	0.70	1.320	0.44	0.844	0.28
<b>6</b>	min.	2.980	0.50	2.290	0.38	1.480	0.25	0.977	0.16
<b>24</b>	min.	3.210	0.13	2.590	0.11	1.760	0.07	1.220	0.05
<b>4</b>	day	3.590	0.04	2.960	0.03	2.070	0.02	1.470	0.02
<b>10</b>	day	4.330	0.02	3.620	0.02	2.560	0.01	1.830	0.01
<b>Zone 3</b>									
<b>5</b>	min.	0.753	9.04	0.584	7.01	0.368	4.42	0.228	2.74
<b>10</b>	min.	1.150	6.90	0.889	5.33	0.560	3.36	0.348	2.09
<b>12</b>	min.	-	6.41	-	4.96	-	3.12	-	1.94

**TABLE 6.3.2 Participation for Zones 1-4**

Partial Duration		500 year		100 year		10 year		2 year	
		Depth (in)	Intensity in/hr	Depth (in)	Intensity in/hr	Depth (in)	Intensity in/hr	Depth (in)	Intensity in/hr
<b>15</b>	min.	1.420	5.68	1.100	4.40	0.693	2.77	0.431	1.72
<b>30</b>	min.	1.910	3.82	1.480	2.96	0.934	1.87	0.580	1.16
<b>60</b>	min.	2.370	2.37	1.840	1.84	1.160	1.16	0.718	0.72
<b>2</b>	min.	2.810	1.41	2.150	1.08	1.340	0.67	0.845	0.42
<b>3</b>	min.	2.890	0.96	2.220	0.74	1.400	0.47	0.895	0.30
<b>6</b>	min.	3.090	0.52	2.430	0.41	1.570	0.26	1.010	0.17
<b>24</b>	min.	3.570	0.15	2.840	0.12	1.900	0.08	1.300	0.05
<b>4</b>	day	4.000	0.04	3.290	0.03	2.290	0.02	1.620	0.02
<b>10</b>	day	4.940	0.02	4.100	0.02	2.890	0.01	2.060	0.01
<b>Zone 4</b>									
<b>5</b>	min.	0.798	9.58	0.624	7.49	0.398	4.78	0.249	2.99
<b>10</b>	min.	1.210	7.26	0.950	5.70	0.606	3.64	0.380	2.28
<b>12</b>	min.	-	6.77	-	5.31	-	3.38	-	2.12
<b>15</b>	min.	1.510	6.04	1.180	4.72	0.751	3.00	0.471	1.88
<b>30</b>	min.	2.030	4.06	1.590	3.18	1.010	2.02	0.634	1.27
<b>60</b>	min.	2.510	2.51	1.960	1.96	1.250	1.25	0.784	0.78
<b>2</b>	min.	3.010	1.51	2.330	1.17	1.470	0.74	0.933	0.47
<b>3</b>	min.	3.120	1.04	2.420	0.81	1.530	0.51	0.991	0.33
<b>6</b>	min.	3.340	0.56	2.640	0.44	1.730	0.29	1.150	0.19
<b>24</b>	min.	4.490	0.19	3.600	0.15	2.400	0.10	1.640	0.07
<b>4</b>	day	5.910	0.06	4.750	0.05	3.200	0.03	2.200	0.02
<b>10</b>	day	7.760	0.03	6.270	0.03	4.260	0.02	2.950	0.01

The principal design storm is the 100-year event defined by the NOAA Atlas 14 Volume 1 Version 5, and subsequent updates. Tables A-2, A-8, and A-9 will be updated when NOAA Atlas 14 precipitation depths are updated. For certain applications (e.g., street drainage, low flow channels and sediment transport) storms of greater frequency than the 100-year storm must be considered and the 500-year storm is used for some floodplains.



### Section. 6-3(A)(2) Land Treatments

All land areas are described by one of four basic land treatments or by a combination of the four land treatments. Land treatments are given in [TABLE 6.2.3](#).

TABLE 6.3.3 Land Treatments	
Treatment	Land Condition
A (CN=77)	Soil uncompacted by human activity with 0 to 10 percent slopes. Native grasses, weeds and shrubs in typical densities with minimal disturbance to grading, ground cover and infiltration capacity.
B (CN=79)	Irrigated lawns, parks and golf courses with 0 to 10 percent slopes. Native grasses, weeds and shrubs, and soil uncompacted by human activity with slopes greater than 10 percent and less than 20 percent.
C (CN=86)	Soil compacted by human activity. Minimal vegetation. Unpaved parking, roads, trails. Most vacant lots. Gravel or rock (desert landscaping). Irrigated lawns and parks with slopes greater than 10 percent. Native grasses, weeds and shrubs, and soil uncompacted by human activity with slopes at 20 percent or greater. Native grass, weed and shrub areas with clay or clay loam soils and other soils of very low permeability as classified by SCS Hydrologic Soil Group D.
D (CN=98)	Impervious areas, pavement and roofs. Ponds, channels and wetlands, even if seasonally dry.

*Most watersheds contain a mix of land treatments. To determine proportional treatments, measure respective subareas. For large developed basins the areal percentages in [TABLE 6.2.4](#)*

TABLE 6.3.4 Percent Treatment D (Impervious)	
Land Use	Percent
Commercial*	90
Single Family Residential N=units/acre, N > 6	$7 \sqrt{(N^2) + (5N)}$
Multiple Unit Residential Detached*	60
Attached*	70

TABLE 6.3.4 Percent Treatment D (Impervious)	
Land Use	Percent
Industrial Light*	70
Heavy*	80
Parks, Cemeteries	7
Playgrounds	13
Schools	50

**TABLE 6.3.4 Percent Treatment D (Impervious)**

Land Use	Percent
Collector & Arterial Streets	90

*\*Includes local streets*

[TABLE 6.2.4](#) does not provide areal percentages for land treatments A, B and C. Use of [TABLE 6.12.16](#) will require additional analysis to determine the appropriate areal percentages of these land treatments.

### Section. 6-3(A)(3) Abstractions

Initial abstraction is the precipitation depth which must be exceeded before direct runoff begins. Initial abstraction may be intercepted by vegetation, retained in surface depressions, or absorbed on the watershed surface. Initial abstractions are shown in [TABLE 6.2.5](#).

**TABLE 6.3.5 Initial Abstraction**

Treatment	Initial Abstraction (inches)
A	0.65
B	0.50
C	0.35
D	0.10

Infiltration is the only significant abstraction after the initial abstraction. After initial abstraction is satisfied, treat infiltration as a constant loss rate as specified in [TABLE 6.2.6](#).

**TABLE 6.3.6 Infiltration (INF)**

Treatment	Loss Rate (inches/hour)
A	1.67
B	1.25
C	0.83
D	0.04*

*\*Treatment D infiltration rate is applicable from 0 to 3 hours; use uniform reduction from 3 to 6 hours, with no infiltration after 6 hours.*

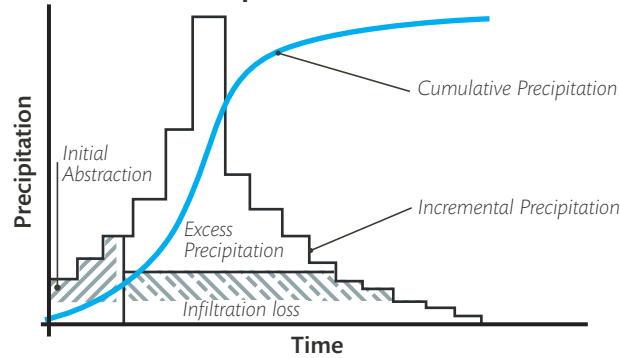
Runoff from a previous event can saturate a channel bed or pond bottom, rendering it minimally pervious for several days. Do not anticipate additional bed losses for design purposes.

### Section. 6-3(A)(4) Excess Precipitation & Volumetric Runoff

Excess precipitation, E, is the depth of precipitation remaining after abstractions are removed. Excess precipitation does not depend on watershed area.

Excess precipitation is determined by subtracting the initial abstraction and infiltration from the design storm hydro graph. [FIGURE 6.2.4](#) illustrates the development of excess precipitation.

**FIGURE 6.3.4 Precipitation and Time**



The 6 hour excess precipitation, E, by zone and treatment is summarized in [TABLE 6.2.7](#).

<b>TABLE 6.3.7 8 - 6 Hour Excess, 'E'</b>				
<b>Zone</b>	<b>Land Treatment</b>			
	<b>A</b>	<b>B</b>	<b>C</b>	<b>D</b>
<b>100 YEAR EXCESS PARTICIPATION, E (IN)</b>				
1	0.55	0.73	0.95	2.24
2	0.62	0.80	1.03	2.33
3	0.67	0.86	1.09	2.58
4	0.76	0.95	1.20	3.34
<b>2 YEAR EXCESS PARTICIPATION, E (IN)</b>				
1	0.00	0.01	0.13	0.92
2	0.00	0.02	0.16	0.98
3	0.00	0.05	0.19	1.05
4	0.00	0.28	0.87	1.39
<b>10 YEAR EXCESS PARTICIPATION, E (IN)</b>				
1	0.11	0.26	0.43	1.43
2	0.15	0.30	0.48	1.51
3	0.18	0.34	0.52	1.64
4	0.25	0.41	0.59	2.15

To determine the volume of runoff:

1. Determine the area in each treatment,  $A_A, A_B, A_C, A_D$
2. Compute the weighted excess precipitation, E

$$\text{EQUATION 7.1 Weighted E} = E_A A_A + E_B A_B + E_C A_C + E_D A_D$$

$$\frac{A_A + A_B + A_C + A_D}{12}$$

3. Multiply the weighted E by the watershed area.

**EQUATION 7.2**  $V_{360}$  (as volume) = weighted E \* (A<sub>A</sub> + A<sub>B</sub> + A<sub>C</sub> + A<sub>D</sub>)

**EXAMPLE 1**

Find the 100-year  $V_{360}$  for 30 acres in zone 1. Eight acres are treatment A, 10 acres are treatment B, 5 acres are treatment C, and 7 acres are treatment D.

**Weighted E** = ((8 \* 0.55) + (10 \* 0.73) + (5 \* 0.95) + (7 \* 2.24)) / 30  
= 1.071 inches

**Volume** = (0.965 \* 30) / 12 = 2.68 acre-ft. =  $V_{360}$

For ponds which hold water for longer than 6 hours, longer duration storms are required to establish runoff volumes. Since the additional precipitation is assumed to occur over a long period, the additional volume is based on the runoff from the impervious areas only.

For 24-hour storms:

**EQUATION 7.3**  $V_{1440} = V_{360} + A_D * (P_{1440} - P_{360}) / 12$  in/ft

For 4-day storms:

**EQUATION 7.4**  $V_{4DAYS} = V_{360} + A_D * (P_{4DAYS} - P_{360}) / 12$  in/ft

For 10-day storms:

**EQUATION 7.5**  $V_{10DAYS} = V_{360} + A_D * (P_{10DAYS} - P_{360}) / 12$  in/ft

**EXAMPLE 2**

Find the 100-year 24-hour and 4-day runoff volume,  $V_{1440}$  and  $V_{4days}$  for the area in [EXAMPLE 1](#).

$V_{360} = 2.68$  acre-feet

$V_{1440} = 2.68 + 7 \text{ ac} * (2.49 - 2.17) / 12 = 2.87$  acre-feet

$V_{4DAYS} = 2.68 + 7 \text{ ac} * (3.12 - 2.17) / 12 = 3.23$  acre-feet

### Section. 6-3(A)(5) Peak Discharge Rate for Small Watersheds

The peak discharge rate is given in Table A-9 for small watersheds, less than or equal to 40 acres, where the time of concentration is assumed to be 12 minutes.

TABLE 6.3.8 Peak Discharge				
Zone	Land Treatment			
	A	B	C	D
<b>100 YEAR PEAK DISCHARGE (CSF/ACRE)</b>				
1	1.54	2.16	2.87	4.12
2	1.71	2.36	3.05	4.34
3	1.84	2.49	3.17	4.49
4	2.09	2.73	3.41	4.78
<b>2 YEAR PEAK DISCHARGE (CSF/ACRE)</b>				
1	0.00	0.02	0.50	1.56
2	0.00	0.08	0.61	1.66
3	0.00	0.15	0.71	1.73
4	0.00	0.28	0.87	1.88
<b>10 YEAR PEAK DISCHARGE (CSF/ACRE)</b>				
1	0.30	0.81	1.46	2.57
2	0.41	0.95	1.59	2.71
3	0.51	1.07	1.69	2.81
4	0.70	1.28	1.89	3.04

To determine the peak rate of discharge,

1. Determine the area in each treatment,  $A_A, A_B, A_C, A_D$
2. Multiply the peak rate for each treatment by the respective areas and sum to compute the total  $Q_p$ .

**EQUATION 7.6** 
$$\text{Total } Q_p = Q_{PA} A_A + Q_{PB} A_B + Q_{PC} A_C + Q_{PD} A_D$$

#### EXAMPLE 3

Find 100-year  $Q_p$  for 14 acres in zone 1. The four land treatments are: 3 acres in treatment A, 5 acres in treatment B, 2 acres in treatment C and 4 acres in treatment D.

$$\text{Total } Q_p = (1.54 * 3) + (2.16 * 5) + (2.87 * 2) + (4.12 * 4) = 37.64 \text{ cfs}$$

Approximately the same results can be achieved by a Rational Method solution. The 0.2-hour (12-minute) peak intensities,  $I$ , are given in [TABLE 6.2.2](#) and Rational Method coefficients,  $C$ , are given in [TABLE 6.2.9](#).

$$\text{EQUATION 7.7 Total } Q_p = (C_A * I * A_A) + (C_B * I * A_B) + (C_C * I * A_C) + (C_D * I * A_D)$$

**TABLE 6.3.9 Coefficient C**

Zone	Land Treatment			
	A	B	C	D
<b>100 YEAR PEAK DISCHARGE (CSF/ACRE)</b>				
1	0.34	0.47	0.63	0.90
2	0.36	0.49	0.63	0.90
3	0.37	0.50	0.64	0.91
4	0.39	0.51	0.64	0.90
<b>2 YEAR PEAK DISCHARGE (CSF/ACRE)</b>				
1	0.00	0.01	0.28	0.89
2	0.00	0.04	0.33	0.89
3	0.00	0.08	0.37	0.89
4	0.00	0.13	0.41	0.89
<b>10 YEAR PEAK DISCHARGE (CSF/ACRE)</b>				
1	0.11	0.28	0.51	0.90
2	0.14	0.32	0.53	0.90
3	0.16	0.34	0.54	0.90
4	0.21	0.38	0.56	0.90

*Note the quote from the [ASCE Manual and Report on Engineering Practice No. 37 \(1969\)](#): The commonly reported Rational C values "are applicable for storms to 5- to 10-yr. frequencies. Less frequent, higher intensity storms will require the use of higher coefficients because infiltration and other losses have a proportionally smaller effect on runoff." Thus higher C's realized under heavy precipitation might be expected.)*

**EXAMPLE 4** Recompute [EXAMPLE 3](#) using the Rational Method.

$$\begin{aligned}
 Q &= C I A \\
 &= (0.27 * 4.02 * 3) + (0.43 * 4.02 * 5) + (0.61 * 4.02 * 2) + (0.93 * 4.02 * 4) \\
 &= 37.13 \text{ cfs}
 \end{aligned}$$

### Section. 6-3(A)(6) Use of Rational Method for Watersheds Larger than 40 Acres

Peak rates of discharge may be computed for watersheds larger than 40 acres by using the Rational Method Coefficients (C's) from [TABLE 6.2.9](#) and modifying the Intensity (in/hr) for a larger time of concentration (t<sub>c</sub>). This method may be used to establish peak flow rates for off-site flow areas when sizing channels, pipes and road crossings. On-site areas should be divided into 40 acre or smaller sub-basins and should not use this procedure. For watersheds larger than 40 acres, the rational method should not be used to establish allowable

historic flow rates since it will tend to give somewhat larger values than those computed by unit hydro graph procedures.

The procedures outlined in [Part. 6-2\(B\)](#) should be used to compute the time of concentration ( $t_c$ ).

Then compute the Intensity (in/hour), using the time of concentration,  $t_c$  and linear interpolation between the intensities given in [TABLE 6.2.2](#) to get the intensity corresponding to the  $t_c$  calculated using the procedures in [Part. 6-2\(B\)](#).

Do not use this formula for  $t_c$  larger than 2.0 hours.

**EXAMPLE 5**

Find  $Q_p$  for a 100-year storm at a 120 acre watershed in zone 3, with a 2600 feet shallow concentrated flow upper subreach at 0.015 ft/ft slope and 1200 feet natural channel lower subreach at 0.02 ft/ft slope. The watershed is 50 percent treatment A, 20 percent treatment B, 10 percent treatment C and 20 percent treatment D.

Compute the time of concentration using [TABLE 6.2.10](#) from [Part. 6-2\(B\)](#) as follows:

With a reach length longer than 2000 feet, use  $K = 3$  for the portion below the first 2000 feet.

Since total reach length (2600 + 1200) is less than 4000 feet use equations b-1 and b-2 from [Part. 6-2\(B\)](#).

$$t_c = \left( \frac{2000}{(10 * 2 * (0.015^{0.5}))} \right) + \left( \frac{600}{(10 * 3 * (0.015^{0.5}))} \right) + \left( \frac{1200}{(10 * 3 * (0.02^{0.5}))} \right) / 60 = 21 \text{ min.}$$

Compute the Intensity,  $I$ , using linear interpolation between the 15 min and 30 min 100 year intensities of 4.40 and 2.96 in/hr from [TABLE 6.2.2](#) as follows:

$$I = 4.40 - [(21-15)/(30-15)] * (4.40-2.96) = 3.82 \text{ inches/hour}$$

Using equation EQUATION 7.7 and the percentage of treatment types:

When:

- $A_A = 120 * 0.50 = 60 \text{ acres}$
- $A_B = 120 * 0.20 = 24 \text{ acres}$
- $A_C = 120 * 0.10 = 12 \text{ acres}$
- $A_D = 120 * 0.20 = 24 \text{ acres}$

$$Q_p = (0.37 * 3.82 * 60) + (0.50 * 3.82 * 24) + (0.64 * 3.82 * 12) + (0.91 * 3.82 * 24) = 243.41 \text{ cfs}$$



### Section. 6-3(A)(7) Hydrograph for Small Watershed

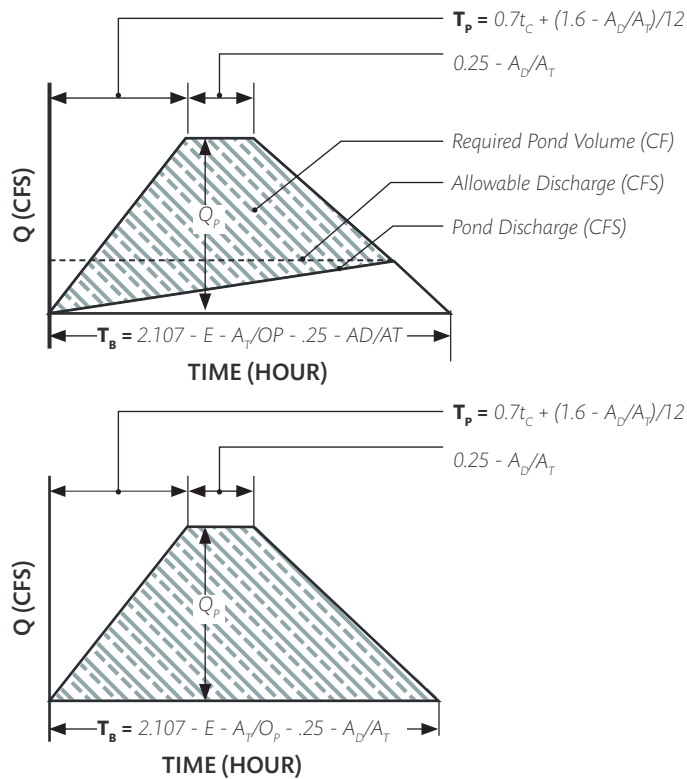
Base time,  $t_b$ , for a small watershed hydrograph is,

$$\text{EQUATION 7.8 } t_b = (2.107 * E * A_T / Q_p) - (0.25 * A_D / A_T)$$

Where  $t_b$  is in hours, E is the excess precipitation in inches (from [TABLE 6.2.7](#)),  $Q_p$  is the peak flow in cfs,  $A_D$  is the area in treatment D, and  $A_T$  is the total area in acres. Using the time of concentration,  $t_c$  (hours), the time to peak in hours is:

$$\text{EQUATION 7.9 } t_p = (0.7 * t_c) + ((1.6 - (A_D / A_T)) / 12)$$

FIGURE 6.3.5 Time to Peak in Hours



### Part. 6-3(B) Time of Concentration, Lag Time, and Time to Peak

There is a delay, after a brief heavy rain over a watershed, before the runoff reaches its maximum. The length of time it takes for runoff from a watershed to reach an analysis point affects the peak runoff rate, with shorter times producing higher peak flow for a constant runoff volume. The velocity at which water can flow through a watershed and the length of flow path are used to determine the time factors. Time of concentration, lag time, and time to peak are three related watershed parameters that are used to determine peak rates of runoff.

### Section. 6-3(B)(1) Definitions

The three time parameters used are defined as follows:

3. **Time of concentration ( $t_c$ )** = time it takes for runoff to travel from the hydraulically most distant part of the watershed basin to the basin outlet or point of analysis
4. **Lag time ( $L_g$ )** = time from the center of unit rainfall excess to the time of the peak flow of the unit runoff hydrograph.
5. **Time to peak ( $t_p$ )** = time from the beginning of unit rainfall excess to the time of the peak flow of the unit runoff hydrograph.

The three time parameters can be computed using the procedures identified in this section. The peak discharge rates and intensity factors identified in and [TABLE 6.2.9](#) were computed using a time of concentration ( $t_c$ ) of 0.2 hour. The procedures in [Part. 6-2\(B\)](#) require the computation of time to peak ( $t_p$ ) as specified herein.

### Section. 6-3(B)(2) Computation of Time of Concentration

Two different equations are used to compute time of concentration ( $t_c$ ) for larger watersheds. For subbasin reach lengths shorter than 4000 feet the SCS Upland Method is used. A transition equation is used for subbasin reach lengths between 4000 and 12000 feet. For subbasin reach lengths longer than 12000 feet, divide the subbasin into smaller subbasins. Use of the USDI Bureau of Reclamation lag time equation is not recommended, instead the subbasins should be routed.

Consideration should be given to splitting large watersheds into smaller subbasins with reach lengths less than 4000 feet. Smaller subbasins will allow more accurate modeling of channels and basin topography, and should provide for greater modeling accuracy.

1. For subbasin reach lengths less than 4000 feet compute time of concentration,  $t_c$  (hours), for the entire (pervious and impervious) watershed by the SCS Upland Method, the sum of the travel times in the subreaches comprising the longest flow path to the watershed outlet.

$$\text{EQUATION 7.10 } t_c = (L_1 / V_1 + L_2 / V_2 + \dots + L_n / V_n) / 3600$$

and,

$$(L_1 + L_2 + \dots + L_n) < 4000 \text{ feet}$$

where:

$t_c$  = time of concentration for the subbasin, in hours. If  $t_c$  is computed to be less than 0.2 hours, use  $t_c = 0.2$  hours.

$L_x$  = the subreach length for the  $n^{\text{th}}$  subreach in feet

$V_n$  = subreach velocity for the  $n^{\text{th}}$  subreach, in feet per second

The subreach velocity  $V_n$  is as determined by the following equation:

$$\text{EQUATION 7.11 } v_n = K (s \cdot 100)^{0.5} = 10K (s)^{0.5}$$

where:

**K** = conveyance factor, per [TABLE 6.2.10](#), unitless

**s** = slope, in feet/feet

**TABLE 6.3.10 Conveyance Factors**

<b>K</b>	<b>Conveyance Condition</b>
0.7	Turf, landscaped areas and undisturbed natural areas (sheet flow* only).
1	Bare or disturbed soil areas and paved areas (sheet flow* only).
2	Shallow concentrated flow (paved or unpaved).
3	Street flow, storm drains less than 48" diameter, natural channels, and that portion of subbasins (without constructed channels) below the upper 2000 feet for subbasins longer than 2000 feet.
4	Constructed channels (for example: riprap, soil cement or concrete lined channels).
7	Storm drains 48" diameter and larger.

\* Sheet flow is flow over plane surfaces, with flow depths up to 0.1 feet. Sheet flow applies only to the upper 400 feet (maximum) of a subbasin.

For composite reaches where the basin slope is not uniform, the composite basin conveyance condition, K, can be computed using the following equation:

**EQUATION 7.12**

$$K = (L / \sqrt{s}) / (L_1 / (K_1 * \sqrt{s})) + (L / \sqrt{s}) / (L_2 / K_2 * \sqrt{s}) + \dots + (L / \sqrt{s}) / (L_n / K_n \sqrt{s})$$

**where:**

$$L = L_1 + L_2 + \dots + L_n$$

**and,**

$$L = L_1 + L_2 + \dots + L_n$$

- For subbasin reach lengths between 4000 and 12000 feet compute the time of concentration,  $t_c$  (hours), for the entire watershed using the following equation:

**EQUATION 7.13**

$$t_c = ((12000 - L) / (72000 * K * s^{0.5})) + ((L - 4000) * K_N * (L_{CA} / L)^{0.33} / (552.2 * s^{0.165}))$$

**where:**

**K** = Conveyance factor from [TABLE 6.2.10](#). For composite reaches, K is computed using the equations for [EQUATION 7.11](#) and [EQUATION 7.12](#).

**L** = distance of longest watercourse, in feet.

**L<sub>CA</sub>** = distance along L from point of concentration to a point opposite centroid of drainage basin, in feet.

**s** = overall slope of L, in foot per foot. For composite reaches s is computed using the equation for [EQUATION 7.11](#).

**K<sub>N</sub>** = a basin factor based on an estimate of the weighted, by stream length, average Manning's n value for the principal watercourses in the drainage basin. For the Albuquerque area, values of K<sub>N</sub> may be estimated from [TABLE 6.2.11](#).

TABLE 6.3.11 LAG EQUATION BASIN FACTORS

$K_N$	Basin Condition
0.042	Mountain Brush and Juniper
0.033	Desert Terrain (Desert Brush)
0.025	Low Density Urban (Minimum improvements to watershed channels)
0.021	Medium Density Urban (Flow in streets, storm sewers and improved channels)
0.016	High Density Urban (Concrete and rip-rap lined channels)

- For subbasin reach length greater than 12000 feet:  
Compute the time of concentration,  $t_C$  (hours), for the entire watershed by first computing the lag time using the USDI Bureau of Reclamation (BR) lag time equation as follows:

**EQUATION 7.14**

$$L_g = 26 * K_N * ((L * L_{CA} / (5280^2 * (s * 5280)^{0.5}))^{0.33})$$

**where:**

$L_g$  = Lag time, in hours

The time of concentration,  $t_c$  (hours), is computed from the lag time,  $L_g$  (hours), by the following equation:

$$EQUATION 7.15 \quad t_c = (4 / 3) * L_g$$

### Section. 6-3(B)(3) Computation of NRCS Lag Time

Note that there are two different definitions of Lag Time:

- The BR method used to determine  $t_c$  for basins longer than 12,000 feet, described above and
- The NRCS method used with the SCS Curve Number method of hydro-graph computation described in [Part. 6-2\(C\)](#) which is calculated as follows:

$$EQUATION 7.16 \quad L_g = 0.6t_c$$

### Section. 6-3(B)(4) Computation of Time to Peak

For the procedures outlined in [Part. 6-2\(C\)](#), the time to peak ( $t_p$ ) is assumed to be a constant ratio of the time of concentration ( $t_c$ ). The following equation is used to compute time to peak:

$$EQUATION 7.17 \quad t_p = (2 / 3) * t_c$$

**EXAMPLE 6**

Find the time of concentration ( $t_c$ ) for a watershed with a 4000 feet desert terrain upper reach (shallow concentrated flow) at 0.015 ft/ft slope and a 3000 feet low density urban lower reach (streets and natural channels) at 0.02 ft/ft slope. The distance to the centroid point is 60% of the total reach length.

$$L = 4000 + 3000 = 7000 \text{ ft}$$

$$L_{CA} / L = 0.60$$

$$s = (0.015 * 4000 + 0.02 * 3000) / 7000 = 0.01714 \text{ foot per foot}$$

$$K_N = (0.033 * 4000 + 0.025 * 3000) / 7000 = 0.030$$

**from**

$$K = (7000 / (0.01714^{0.5})) / ((2000 / (2 * (0.015^{0.5}))) + (2000 / (3 * (0.015^{0.5}))) + (3000 / (3 * (0.02^{0.5})))) = 2.59$$

$$t_c = ((12000 - 7000) / (72000 * 2.59 * 0.01714^{0.5})) + ((7000 - 4000) * 0.030 * 0.60^{0.33} / (552.2 * 0.01714^{0.165})) = 0.2048 + 0.2694 = 0.4742 \text{ hours}$$

**EXAMPLE 7**

Find the time of concentration ( $t_c$ ), lag time ( $L_G$ ) and time to peak ( $t_p$ ) for a watershed with a 8000 feet desert terrain upper reach at 0.015 ft/ft slope and a 6000 feet low density urban lower reach at 0.02 ft/ft slope. The distance to the centroid point is 60% of the total reach length.

$$L = 8000 + 6000 = 14000 \text{ feet}$$

$$L_{CA} = 0.60 * 14000 = 8400 \text{ feet}$$

**use**

$$s = (0.015 * 8000 + 0.02 * 6000) / 14000 = 0.01714 \text{ ft/ft}$$

$$K_N = (0.033 * 8000 + 0.025 * 6000) / 14000 = 0.030$$

**use**

$$L_G = 26 * 0.030 * ((14000 * 8400 / (52802 * (0.01714 * 5280)^{0.5})))^{0.33} = 0.596 \text{ hours}$$

$$t_c = (4/3) * 0.596 = 0.795 \text{ hours}$$

$$t_p = (2/3) * 0.795 = 0.530 \text{ hours}$$

### Section. 6-3(B)(5) Time of Concentration for Steep Slopes and Natural Channels

The procedures used to compute time of concentration ( $t_c$ ) as described in [Section. 6-2\(B\)\(2\)](#) may compute values that are too small to be sustained for natural channel conditions. In natural channels, flows become unstable when a Froude Number of 1.0 is approached. The procedures identified in [Section. 6-2\(B\)\(2\)](#) may compute flow velocities for steep slopes that indicate supercritical flow conditions, even though such supercritical flows cannot be sustained for natural channels.

For steep slopes, natural channels will likely experience chute and pool conditions with a hydraulic jump occurring at the downstream end of chute areas; or will experience a series of cascading flows with very steep drops interspersed with flatter channel sections.

For the purposes of this section, steep slopes are defined as those greater than 0.04 foot per foot. The procedures outlined in this section should not be used for the following conditions:

1. Slopes flatter than 0.04 foot per foot.
2. Channels with irrigated grass, riprap, soil cement, gabion, or concrete lining which cannot be clearly identified as natural or naturalistic.
3. The hydraulic design of channels or channel elements. The purpose this section is to define procedures for hydrologic analysis only. The design of facilities adjacent to or within channels with chute and pool conditions cannot be analyzed with the simplified procedures identified herein. It may be necessary to design such facilities for the supercritical flows of chutes (for sediment transport, local scour, stable material size) and for the hydraulic jump of pool conditions (for maximum water surface elevation and flood protection).

The slope of steep natural watercourses should be adjusted to account for the effective slope that can be sustained. The slope adjustment procedures identified in the Denver - Urban Drainage and Flood Control District (UDFCD) [Urban Storm Drainage Criteria Manual](#) (Figure 4-1, Runoff chapter, 1990) are applicable for the slope adjustment identified herein. In addition, channel conveyance factors (K) should be checked to make sure that appropriate equivalent Froude Numbers are maintained. The UDFCD Figure 4-1 can be approximated by the following equation:

#### EQUATION 7.18

$$s' = 0.052467 + (0.063627 * s) - 0.18197 * e^{(-62.375 * s)}$$

#### where:

$s$  = measured slope (foot per foot)

$s'$  = adjusted slope (foot per foot)

The conveyance factors (K) for the upland method should be checked to make sure that appropriate Froude Numbers are maintained. To accomplish this, it is necessary to estimate the peak flow rate from the watershed. Using estimated conveyance factors (K) from Table B-1 and the procedures outlined in Part A, an estimated peak flow rate for the basin ( $Q_p$ ) can be computed. The following formulas are then used to compute conveyance factor adjustment:

$$\text{EQUATION 7.19 } \mathbf{K}' = 0.302 * s'^{(-0.5)} * Q_p \text{ (0.18)}$$

$$\text{EQUATION 7.20 } \mathbf{K}'' = 0.207 * s'^{(-0.5)} * Q_p \text{ (0.18)}$$

An adjusted conveyance factor (K) is then obtained based on the following:

$$\begin{array}{ll} \text{if } K > K' & \text{then } K = K' \\ \text{if } K' \geq K \geq K'' & \text{then } K = K \text{ (no adjustment)} \\ \text{if } K < K'' & \text{then } K = K'' \end{array}$$

Recompute  $Q_p$  based on the revised conveyance factor (K) using the procedures in [Part. 6-2\(B\)](#) or [Part. 6-2\(C\)](#) as appropriate. If the recomputed  $Q_p$  is within 10 percent of the  $Q_p$  used to compute  $K'$  and  $K''$ , the estimate is sufficiently accurate. If the recomputed  $Q_p$  is more than 10 percent from the  $Q_p$  used to compute  $K'$  and  $K''$ , repeat the process using the revised  $Q_p$ .

The Lag Equation Basin Factors,  $K_N$ , from [TABLE 6.2.11](#) remain applicable when using equations [EQUATION 7.8](#) and [EQUATION 7.9](#) with the adjusted slope computed by the equation shown in [EQUATION 7.12](#).

#### EXAMPLE 8

Compute the time of concentration ( $t_c$ ) for a natural basin having a length of 4,000 feet and a uniform slope of 0.12 foot per foot. The basin is estimated to have a peak flow of 600 cfs using the procedures in [Part. 6-2\(B\)](#).

$$s = 0.12 \text{ foot per foot}$$

$$Q_p = 600 \text{ cfs}$$

Compute the adjusted slope using [EQUATION 7.18](#).

$$\begin{aligned} s' &= 0.052467 + 0.063627 * 0.12 - 0.18197 * (e^{(-62.375 * 0.12)}) \\ &= 0.052764 + 0.007635 - 0.000102 = 0.0603 \text{ ft/ft} \end{aligned}$$

Compute conveyance factors from [TABLE 6.2.10](#) and [EQUATION 7.9](#).

$$K = 4000 / (300 / 0.7 + 1700 / 2.0 + 2000 / 3.0) = 2.056$$

From [EQUATION 7.19](#) and [EQUATION 7.20](#).

$$K' = 0.302 * (.0603)^{(-0.5)} * (600)^{0.18} = 3.89$$

$$K'' = 0.207 * (.0603)^{(-0.5)} * (600)^{0.18} = 2.66$$

Since  $K < K''$  then use  $K = 2.66$

From [EQUATION 7.6](#) and b-2.

$$V = 10 * 2.66 * (0.0603^{0.5}) = 6.53 \text{ ft/sec}$$

$$t_c = (4000 / 6.53) / 3600 = 0.170 \text{ hour (Use 0.200 hour min.)}$$

The  $Q_p$  should then be recomputed using the revised  $t_c$  and the procedures in [Part. 6-2\(A\)](#) or [Part. 6-2\(C\)](#).

### Section. 6-3(B)(6) Channel Routing for Steep Slopes and Natural Channels

The procedures outlined to compute time of concentration for steep natural channels in [Section. 6-2\(B\)\(5\)](#) are also applicable for hydrologic routing of hydrographs through channel segments. The restrictions which limit the procedure only to natural channels with slopes steeper than 0.04 foot per foot are also applicable here. The procedures are not applicable to the hydraulic design of channel structures.

[EQUATION 7.12](#) can be used to obtain an adjusted slope for the channel segment. The Manning's roughness ( $n$ ) for the channel should be checked to make sure that appropriate Froude Numbers are maintained. It is necessary to estimate the peak flow rate ( $Q_p$ ) for the watershed channel segment to perform this check. An analysis without a Manning's roughness adjustment may be used for the initial estimate. The following formula is then used to compute the Manning's roughness adjustment:

$$\text{EQUATION 7.21 } n' = 0.122 * s'^{(0.5)} * Q_p^{(0.06)}$$

An adjusted Manning's roughness ( $n$ ) is then obtained based on the following:

if  $n < n'$  then  $n = n'$

if  $n \geq n'$  then  $n = n$  (no adjustment)

Recompute the  $Q_p$  based on the revised Manning's roughness ( $n$ ). If the recomputed  $Q_p$  is within 30 percent of the  $Q_p$  used to compute  $n'$ , the estimate is sufficiently accurate. If the recomputed  $Q_p$  is more than 30 percent from the  $Q_p$  used to compute  $n'$ , repeat the process using the revised  $Q_p$ .

#### EXAMPLE 9

A channel segment immediately downstream of the basin in [EXAMPLE 8](#) has a slope of 0.08 foot per foot. The channel has an apparent Manning's roughness of 0.035. Compute the equivalent channel slope and Manning's roughness for use in hydrologic routing.

$s = 0.08$  foot per foot

$Q_p = 600$  cfs

$$\begin{aligned} s' &= 0.052467 + 0.063627 * 0.08 - 0.18197 * e^{(-62.375 * 0.08)} \\ &= 0.052467 + 0.005090 - 0.001238 = 0.0563 \text{ ft/ft} \end{aligned}$$

Use **equivalent slope** = 0.0563 ft/ft (from [EQUATION 7.21](#))

$$n' = 0.122 * (0.0563)^{0.5} * (600)^{0.06} = 0.0425$$

Since  $n < n'$ , then use  $n = 0.0425$



## Part. 6-3(C) Procedure for Small and Large Watersheds

A unit hydrograph procedure is used for major drainage area analysis and for sub-basins larger than 40 acres. The [Part. 6-2\(C\)](#) procedure may also be utilized for small watersheds (40 acres or less) in place of the procedures specified in [Part. 6-2\(A\)](#). AHYMO is the primary method of hydrograph computation using losses described in [TABLE 6.2.5](#) and [TABLE 6.2.6](#) for Land Treatments as described in [TABLE 6.2.3](#) and a rainfall distribution with peak intensity 1.5 hours after the beginning of the storm. The SCS Curve Number method is also allowed using Curve Numbers listed in [TABLE 6.2.3](#) with a 24 hour rainfall distribution based on Atlas 14 (smoothing should not be applied to the Atlas 14 data points) with the peak intensity at 12 hours. The unit hydrograph calculation increment is to be 0.01 hours or less for both the AHYMO and the SCS methods.

### Section. 6-3(C)(1) Computer Program

The unit hydrograph calculations must be accomplished using computer programs that are acceptable to the City of Albuquerque. Consult the User's Manual for direction on how to use each program. Program data files must be included with applications to hydrology. A list of acceptable programs is available on the Hydrology web page of the City of Albuquerque along with requirements for procedures to be used and the format of the printout to be contained in the application for each program.

### Section. 6-3(C)(2) Zones

The unit hydrograph procedure should not utilize precipitation zones from [TABLE 6.2.1](#) or [FIGURE 6.2.3](#) of [Part. 6-2\(B\)](#). The precipitation amounts are obtained for a specific location near the center of the watershed being analyzed from the NOAA Atlas 14. The Latitude and Longitude and Elevation of the "Point Precipitation Frequency Estimates and map showing the location of the point should be included in the documentation. Program parameters are obtained based on basin characteristics and precipitation quantities.

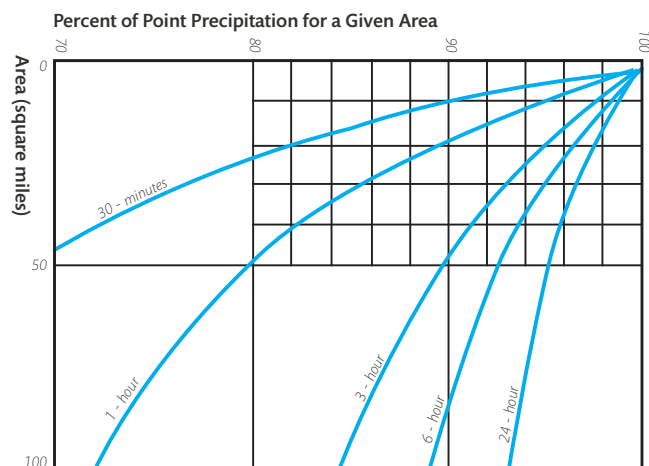
### Section. 6-3(C)(3) Design Storm

The principal design storm for peak flow determination is the 100-year 24-hour event defined by the NOAA Atlas 14, [Precipitation - Frequency Atlas of the United States, Vol. 1 Version 5 Semiarid Southwest](#) or the most current version. Storms of other frequencies or durations are required for design or analysis of volume sensitive facilities, when examining sediment transport, and for complex routing conditions. The following statement from the Federal Emergency Management Agency (FEMA) should be used to provide guidance when selecting storm duration:

*"FEMA's position regarding the duration of rainfall is that the storm must extend for a period long enough to include all rainfall excess when the volume of the runoff hydrograph is an important consideration. This includes conditions when detention storage is involved, when sediment processes are a significant factor, and when combining and routing subbasin hydrographs to obtain watershed runoff."*

When evaluating uncontrolled watersheds larger than five (5) square miles, the precipitation amounts may be reduced by multiplying the precipitation amounts by the "Percent of Point Precipitation" obtained from [FIGURE 6.2.6](#). Uncontrolled watersheds mean those areas not controlled by dams, ponds or partial diversions.

FIGURE 6.3.6 Depth - Area Curves



## Part. 6-3(D) Symbols and Bibliography

### Section. 6-3(D)(1) Definitions of Symbols

When evaluation equations use the following order of precedence: 1) parentheses, 2) functions (i.e., SIN or LOG), 3) power or square root, 4) multiplication or division, 5) addition or subtraction.

TABLE 6.3.12 Definitions of Symbols

Symbol	Definition
$A_A$	area in land treatment A
$A_B$	area in land treatment B
$A_C$	area in land treatment C
$A_D$	area in land treatment D
$A_T$	total area in sub-basin
Ac	Ft acre feet
C	Rational Method coefficient
$C_A$	Rational Method coefficient for treatment A
$C_B$	Rational Method coefficient for treatment B
$C_C$	Rational Method coefficient for treatment C
$C_D$	Rational Method coefficient for treatment D
cfs	cubic feet per second
CN	SCS Curve Number
D	duration in days

**TABLE 6.3.12 Definitions of Symbols**

<b>Symbol</b>	<b>Definition</b>
e	base of natural logarithm system = 2.71828
E	excess precipitation
$E_A$	excess precipitation for treatment A
$E_B$	excess precipitation for treatment B
$E_C$	excess precipitation for treatment C
$E_D$	excess precipitation for treatment D
EA	elevation Adjustment factor for PMP60
Elev	elevation (feet)
Ft	feet
hr	hour
I	Rational Method intensity (inches/hour)
IA	initial abstraction (inches)
INF	infiltration (inches/hour)
K	conveyance factor for SCS Upland Method
k	recession coefficient for HYMO program
$K_N$	basin factor for lag time equation
$K_x$	conveyance factor for watershed subreach
$k/t_{pA}$	k divided by $t_p$ for treatment A
$k/t_{pB}$	k divided by $t_p$ for treatment B
$k/t_{pC}$	k divided by $t_p$ for treatment C
$k/t_{pD}$	k divided by $t_p$ for treatment D
$k/t_{p40}$	k divided by $t_p$ for 40 acres or smaller area
$k/t_{p200}$	k divided by $t_p$ for 200 acres or larger area
L	length of subreach (feet)
$L_{CA}$	distance to centroid of drainage basin (feet)
$L_G$	lag time (hours)
$L_x$	length of watershed subreach
ln	natural logarithm (base e)
$\log_{10}$	base 10 logarithm
mi <sup>2</sup>	square mile(s)
n	Manning's roughness coefficient
$P_{12}$	12-minute precipitation
$P_{60}$	60-minute precipitation at 100-year storm
$P_{60-2}$	60-minute precipitation at 2-year storm
$P_{60-year}$	60-minute precipitation at "year" storm
$P_{360}$	360-minute precipitation at 100-year storm
$P_{360-2}$	360-minute precipitation at 2-year storm
$P_{360-10}$	360-minute precipitation at 10-year storm
$P_{1440}$	1440-minute (24-hr) precipitation, 100-year storm

**TABLE 6.3.12 Definitions of Symbols**

Symbol	Definition
$P_{1440-2}$	1440-minute (24-hr) precipitation at 2-year storm
$P_D$	precipitation for "D"-days duration
$P_{N-100}$	"n"-minute precipitation at 100-year storm
$P_{N-YEAR}$	"n"-minute precipitation at "year" storm
$P_T$	precipitation at any time, t
$Q_p$	peak discharge (cfs)
$Q_{PA}$	peak discharge rate (cfs/acre) for treatment A
$Q_{PB}$	peak discharge rate (cfs/acre) for treatment B
$Q_{PC}$	peak discharge rate (cfs/acre) for treatment C
$Q_{PD}$	peak discharge rate (cfs/acre) for treatment D
s	slope of subreach in foot per foot
t	time in minutes
$t_B$	base time for small watershed hydrograph
$t_C$	time of concentration (hours)
$t_p$	time to peak (hours)
v	velocity of flow in watershed (feet/sec)
$v_x$	velocity of flow in watershed subreach
$V_{360}$	runoff volume for 360-minute storm
$V_{1440}$	runoff volume for 1440-minute storm
$V_{4days}$	runoff volume for 4-day storm
$V_{10days}$	runoff volume for 10-day storm
$y^x$	y to the x power
+	addition operator
-	subtraction operator
*	multiplication operator
/	division operator
$\sqrt{\quad}$	square root operator

### Section. 6-3(D)(2) Bibliography

Alley, W.M. and Smith, P.E., 1982, *Distributed Routing Rainfall-Runoff Model, Version II, Computer Program Documentation, Users Manual*, Open-File Report 82-344, U.S.D.I. Geological Survey, Denver, Colorado, 56 p.

Anderson, C.E., 1992, AHYMO, *Computer Program Users Manual, (AMAFCA Hydrologic Model)*, Albuquerque Metropolitan Arroyo Flood Control Authority, Albuquerque, New Mexico, 44 p.

Anderson, C.E., and Heggen, R.J., 1990, "Evolution of Drainage Criteria, Albuquerque, New Mexico", *Hydraulics/Hydrology of Arid Lands, Proceedings of the International Symposium*, Hydraulics Division, American Society of Civil Engineers, New York, New York, pp. 84-89.

Cudworth, A.G., 1989, *Flood Hydrology Manual*, U.S.D.I. Bureau of Reclamation, Denver, Colorado, 243 p.

Hansen, E.M., Fenn, D.P., Schreiner, L.C., Stodt, R.W., and Miller, J.F., 1988, *Hydrometeorological Report No. 55A, Probable Maximum Precipitation Estimates - United States Between the Continental Divide and the 103rd Meridian*, U.S.D.C. National Oceanic and Atmospheric Administration, Silver Springs, Maryland.

Heggen, R.J., 1987, *Split Ring Infiltration Basic Data Collection and Interpretation*, Report No. PDS 110/210, Bureau of Engineering Research, University of New Mexico, Albuquerque, New Mexico, 28 p.

Huber, W.C., and Dickinson, R.E., 1988, *Storm Water Management Model, Version 4, Users Manual*, Environmental Research Laboratory, U.S. Environmental Protection Agency, Athens, Georgia, 569 p.

James, W.P., 1986, *A & M Watershed Model, Users Manual*, Texas A & M University, College Station, Texas, 281 p.

Geoffrey M. Bonnin, Deborah Martin, Bingzhang Lin, Tye Parzybok, Michael Yekta, David Riley, 2011, NOAA Atlas 14, *Precipitation-Frequency Atlas of the United States, Volume 1 Version 5.0: Semiarid Southwest (Arizona, Southeast California, Nevada, New Mexico, Utah)*, National Oceanic and Atmospheric Administration, Silver Spring, Maryland.

Roesner, L.A., Aldrich, J.A., and Dickinson, R.E., 1988, *Storm Water Management Model, Version 4, Addendum I EXTRAN*, Environmental Research Laboratory, U.S. Environmental Protection Agency, Athens, Georgia, 157 p.

Sabol, G.V., Ward, T.J., and Seiger, A.D., 1982, *Rainfall Infiltration of Selected Soils in the Albuquerque Drainage Area for the Albuquerque Metropolitan Arroyo Flood Control Authority*, Civil Engineering Department, New Mexico State University, Las Cruces, New Mexico, 110 p.

Urban Drainage and Flood Control District, 1969, Update 1990, *Urban Storm Drainage Criteria Manual*, Volume I and II, Denver, Colorado.

U.S. Army Corps of Engineers, 1987, HEC-1, *Flood Hydrograph Package, Users Manual*, Hydrologic Engineering Center, Davis, California, 32 p. plus appendices.

U.S.D.A. Soil Conservation Service, 1969, *National Engineering Handbook, Section 4, Hydrology*, Washington, D.C.

U.S.D.A. Soil Conservation Service, 1983, TR-20 Computer Program for Project Formulation, Hydrology, draft Second Edition, Lanham, Maryland, 302 p.

U.S.D.A. Soil Conservation Service, 1984, TR-48 DAMS2, *Structure Site Analysis Computer Program*, draft, Washington, D.C.

U.S.D.A. Soil Conservation Service, 1986, *TR-55 Urban Hydrology for Small Watersheds*, Second Edition, Washington, D.C.

U.S.D.A Natural Resources Conservation Service, 2010, National Engineering Handbook, Part 630 Hydrology, Chapter 15 Time of Concentration, Washington, D.C.

U.S.D.I. Bureau of Reclamation, 1973, *Design of Small Dams*, Second Edition, Denver, Colorado, 816 p.

U.S.D.I. Bureau of Reclamation, 1987, *Design of Small Dams*, Third Edition, Denver, Colorado, 860 p.

U.S.D.I. Bureau of Reclamation, Flood Section, 1989, *Personal Computer Programs, Estimating Probable Maximum Precipitation and Precipitation Frequency-Duration in the Western United States*, Denver, Colorado, 72 p.

Williams, J.R., 1968, *Runoff Hydrographs from Small Texas Blacklands Watersheds*, ARS-41-143, U.S.D.A. Agricultural Research Service, Riesel, Texas, 24 p.

Williams, J.R., and Hann, R.W., 1973 *HYMO: Problem-Oriented Computer Language for Hydrologic Modeling, Users Manual*, ARS-S-9, U.S.D.A. Agricultural Research Service, Riesel, Texas.

Woolhiser, D.A., Smith, R.E., and Goodrich, D.C., 1990, *KINEROS, A Kinematic Runoff and Erosion Model, Documentation and User Manual*, ARS-77, U.S.D.A. Agricultural Research Service, Tucson, Arizona, 130 p.

## ARTICLE 6-4 SITE DEVELOPMENT

It is beneficial to consider the below listed items when beginning to develop a site:

1. Flood Zone-May affect finished floor elevation, locations of structures and increase permit requirements-[Article 6-6](#)
2. Downstream Capacity-may require onsite ponding - [Article 6-7](#)
3. Offsite flows- in general, are accepted and conveyed through the site - [Article 6-7](#)
4. Applicable approved drainage reports and plans-provides previous approvals for downstream capacity and offsite flows - [Article 6-7](#)
5. Current Topography-accurate depiction of existing conditions
6. Encumbrances-utility corridors and easements may restrict development
7. Water Quality- Design standard volume and construction runoff - [Article 6-12](#)

## ARTICLE 6-5 GRADING AND EROSION CRITERIA

### Part. 6-5(A) Slope Criteria

Earth slopes shall conform to the following criteria:

1. For slopes 3.0 feet high or less, maximum slope should not exceed 2:1 (horizontal to vertical)
2. For slopes greater than 3.0 feet high, maximum slope should not exceed 3:1 (horizontal to vertical) unless stabilized from slope failure through City Engineer approved means. Steeper slopes may be approved subject to a geotechnical recommendation and City Engineer concurrence.
3. All slopes shall be protected from erosion, especially when subjected to upland flows.

### Part. 6-5(B) Grading near the Property Line

Particular attention must be given to grading (either cut or fill) near property lines. Care should be taken to ensure that existing foundations, retaining walls, stable slopes or other structures are not endangered and that the adjacent property is not damaged or its use constrained due to grading at or near the property line.

### Part. 6-5(C) Grading In and Adjacent to Major Facilities

No grading, excavation, or fill may take place in or adjacent to any watercourse defined as a major facility (30 cfs for arroyos and 2 acre-ft for detention basins) without an approved grading and drainage plan.

Construction activities within major facilities shall provide for the safe passage of the 10-year design flow during the months of July, August and September.

### **Part. 6-5(D) Grading In and Adjacent to Major Public Open Space**

1. Width disturbance to slopes and vegetation, and cut and fill, shall be minimized and balanced against the need to provide for bikeways or other amenities within the right-of-way.
2. Materials that blend with the adjacent landscape of the Major Public Open Space in color and texture shall be used. Natural materials are generally preferable to man-made materials.
3. No grading is permitted within Major Public Open Space areas with nine percent or greater slopes except as required for roads, trails, and utilities.
  - a. *Temporary construction barricades, or 20-foot construction setback, are required from Major Public Open Space areas with 9 percent or greater slopes.*
  - b. *If damage due to construction occurs on the Major Public Open Space side of the property line, it shall be mitigated at the expense of the property owner.*
4. Corridors for construction projects shall be located to avoid impacts and destruction of petroglyphs or other archaeological sites and environmentally sensitive areas previously identified.
5. Areas that are damaged or altered shall be restored through replacement of boulders to approximate the original location, angle and surface exposure. Revegetation to approximate original cover with appropriate native or naturalized plants is required within 90 days of project completion.
6. The City shall be responsible for restoring existing damaged areas that lie within Major Public Open Space. The property owner shall be responsible for restoring damaged areas on lands accepted by the City to meet open space requirements; this shall occur prior to title transfer if the land is to be deeded to the City and shall be an ongoing responsibility of the property owner if the land remains private open space.

### **Part. 6-5(E) Means of Erosion Control**

The means of erosion control shall be specified on the grading plan. Steeper slopes require a larger rock. Please refer to the table below for recommended erosion control. Recommendations are for slopes without upland flows:

1. 3:1 to 4:1 - 3/4" or larger rocks
2. 2.5:1 to 3:1 - 1.5" angular rock
3. 2:1 to 2.5:1 - 4" minimum angular hand-placed with no landscape fabric
4. 1.5:1 to 2:1 - 6" or larger angular stone hand placed with no landscape fabric.

Slopes steeper than 1.5:1 may be allowed with a design acceptable to the City Engineer.

For slopes steeper than 5:1 with upland flows, the velocity and flow rate should be considered when designing the erosion protection for the slope.



## Part. 6-5(F) Levees and Berms

### Section. 6-5(F)(1) Definitions

1. **A levee**-FEMA defines a levee as a man-made structure, usually an earth-en embankment, designed and constructed in accordance with sound engineering practices to contain, control or divert the flow of water. Levees in general are used to contain flows from the river or major water course where the grade outside the levee is lower than the 100 year 6-hour water surface elevation.
2. **A berm** is a linear earth structure designed to direct or retain/detain storm water. The height is measured from the uphill side. See the section on Ponds for berms used to retain/ detain stormwater.

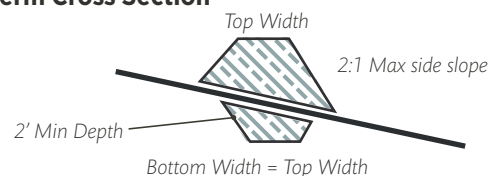
### Section. 6-5(F)(2) Design Criteria

All levees shall be designed to standards published by the Army Corp of Engineers and meet FEMA freeboard requirements. Any berm or levee whose purpose is to divert or convey runoff in a major arroyo (30 cfs or greater) shall be specially designed on a case-by-case basis and shall meet or exceed the guidelines listed herein.

#### 6-5(F)(2)(i) Cross Section

1. The top width should have a minimum width equal to the height of the berm. Construction and maintenance equipment should be considered when considering the top width. The minimum top width is 4 feet.
2. Berms 4 feet and higher must be provided with a structural keyway with bottom width equal to the top width and depth equal to at least half the height, but not less than 2 feet and side slopes not steeper than 2:1 (horizontal to vertical)

FIGURE 6.5.7 Berm Cross Section



3. Unarmored faces of berms must have side slopes not steeper than 3:1 (horizontal to vertical).
4. Safety issues should always be considered when designing slopes.
5. For high velocity
  - a. For velocities 5 fps or greater an engineered means of erosion protection is required for bank protection.
  - b. Erosion protection may be required for velocities less than 5 fps.
  - c. Rip-rap protected side slopes shall not be steeper than 2:1 (horizontal to vertical). Method of rip-rap installation per engineer.
  - d. Concrete faced berms may be used on side slopes greater than 2:1 (horizontal to vertical).

### 6-5(F)(2)(ii) Freeboard

Berms and levees must be provided with freeboard for the 100-year design storm based on the following guidelines:

1. For flow depths less than 2.0 feet; minimum freeboard is 1.0 feet.
2. For flow depths greater than 2.0 feet; minimum freeboard is 2.0 feet

### Section. 6-5(F)(3) **Earthwork for Berms**

All earthen berms and levees shall be constructed of high quality fill material free of debris, organic matter, frozen matter and stones larger than 6 inches in any dimension. The key trench shall be scarified to a depth of 6 inches to ensure bonding with the fill material. Lifts shall not exceed 12 inches of loose material before compaction. The material in each lift shall contain optimum moisture content (-1% to +3%) or per Geotechnical Report and shall be compacted to at least 95% density as determined by ASTM D 1557.

### Section. 6-5(F)(4) **Certification**

All berms 4 feet and higher shall be inspected during construction and certified by a New Mexico Professional Engineer as to their substantial compliance to the approved plans and specifications.

## **ARTICLE 6-6 VALLEY DRAINAGE CRITERIA**

Special considerations are appropriate in the valley due to the flatness of the area and limited storm drain capacity. The valley is defined as the area bounded by: Broadway Blvd/Edith Blvd on the east, the Rio Grande River on the West, and the City limits on the North and South.

### **Part. 6-6(A) Single Lot Residential Development and Additions**

For lots less than one acre, water harvesting on the lot is required. The water harvesting volume goal is to capture a ½ inch of runoff from impervious areas on the site.

1. Roof flows should be directed to the water harvesting area(s).
2. Runoff should not adversely impact adjacent properties.
3. The finished pad elevation is recommended to be a minimum of 18 inches above the edge of pavement or roadway.

### **Part. 6-6(B) Residential Subdivisions**

Property that will be subdivided may require a drainage submittal for DRB approval. The drainage submittal shall categorize the downstream capacity per the following:

1. Discharge from the site will be limited to proven downstream capacity.
2. If the site has limited downstream capacity, the site shall retain the runoff from the 100-yr 6-hour storm on lots or in a subdivision pond.

3. If the site has no downstream capacity, the subdivision shall retain the 100-yr 10-day storm.

### **Part. 6-6(C) Non-Single Family Residential Development and Commercial Properties**

These development types will be subject to the following allowable stormwater discharge rates:

1. 2.75 cfs/acre or
2. The site must retain the first ½" of runoff or the design standard volume as defined in the MS-4 permit, whichever is greater. See [Article 6-12](#).
3. If downstream capacity is known to be more limited, the allowable discharge may be less.

### **Part. 6-6(D) Flat Grading Scheme for Residential Subdivisions**

A flat grading scheme is considered a ponding condition and may be allowed in flat areas such as the Valley region of the City and under the following conditions:

1. There is no outfall or insufficient downstream conveyance for the site.
2. The site must be flat or graded flat.
3. The maximum percent impervious of the lot and the contributing area may not be greater than 45%.
4. Finished pad elevation shall be a minimum of one (1) foot above the 100 year 10-day storm water surface elevation.
5. The flow between the front yard and back yard cannot be obstructed. The storm water must be allowed to equalize to the same level between the front yard and back yard.
6. A permanent perimeter wall or barrier around the development is required to contain the 100 year 10-day storm developed runoff.
7. The high point of all internal streets must be four inches above the 100 year 10-day storm water surface elevation.

## ARTICLE 6-7 DEVELOPING IN OR ADJACENT TO A FLOOD ZONE

The City of Albuquerque participates in the [National Flood Insurance Program \(NFIP\)](#) and therefore development and construction activities in mapped flood zones must follow the requirements of the NFIP and the [Code of Federal Regulations 44 CFR Parts 59, 60, 65 and 70](#).

### Part. 6-7(A) Grading

Grading will not be allowed within a FEMA Special Flood Hazard Area (flood zone) without an approved grading and drainage plan and a Floodplain Development Permit.

A letter of Map Revision will be required when development changes a mapped flood zone. The City Engineer may waive the LOMR requirement for projects involving one acre or less.

### Part. 6-7(B) Compensatory Volume

1. Compensatory volume (AH and AE Zones) is a volume that is provided in the proposed condition that mitigates the displaced volume associated with development. This is most important in AH zones (areas of ponding 1 to 3 feet deep) and ponding AE zones.
2. In an AH or ponding AE Zone the drainage plan is to state the amount of displaced volume in the mapped flood zone and show where this volume is to be accommodated in the proposed condition.

### Part. 6-7(C) AO Zone

When developing adjacent to or in an AO Zone, the cross-sectional area of the flow path is to be preserved. This is to be demonstrated in the drainage plan.

#### Section. 6-7(C)(1) Determination of Base Flood Elevation (BFE) in an AO Zone

If flooding is conveyed by the street, provide the highest top of curb or crown along the property line and add the AO Zone depth (e.g AO 1) to the higher of the two elevations; top of curb or crown.

If the entire property is inundated and the flow is not conveyed by the street, calculate an average grade for the site and add the AO zone depth to the average grade.

If the property is partially inundated and the street does not convey the flow, add the AO Zone depth to the lowest lot elevation.

## **Part. 6-7(D) A Zone**

For developing adjacent or in an unnumbered A Zone, the base flood elevation will be determined by best available data or if no data is available the BFE is 2 feet above the highest adjacent grade.

## **Part. 6-7(E) Floodplain Development Permit**

A *Floodplain Development Permit* is required for any construction in a mapped flood zone as provided by FEMA. This requirement may be waived if the work is minor (e.g. drivepad) and will not result in a change to the water surface elevation or flow path.

## **Part. 6-7(F) Letters of Map Change (LOMC)**

Map changes come in the form of *Letters of Map Revision (LOMR)*, *Letters of Map Amendment (LOMA)*, *Letters of Map Amendment based on Fill (LOMR-F)* and conditional LOMR and LOMR-F (CLOMR, CLOMR-F)

1. A LOMR, if approved by FEMA, will change/remove the mapped flood zone from the Flood Insurance Rate Map (FIRM).
2. A LOMA, if approved by FEMA, will not change the FIRM, but will remove the structure or property from the flood zone for insurance purposes.
3. A LOMR-F, if approved by FEMA, will not change the FIRM, but will remove the structure or property from the flood zone for insurance purposes. If fill was imported to raise the structure above the Base Flood Elevation (BFE), the LOMR-F and not the LOMA is to be submitted to FEMA.
4. A conditional map change (CLOMR, CLOMR-F) is submitted to FEMA prior to grading/building to obtain their approval or receive comments on the proposed project. A conditional map change is always recommended as it shortens the review time upon the completion of the project and minimizes unexpected review responses from FEMA. CLOMR and CLOMR-F's must demonstrate compliance with the Endangered Species Act.

For more information on the above mentioned letters of map change, refer to [FEMA's website](#).

## **Part. 6-7(G) Project Requirements**

1. If the project proposes any grading in a regulated floodway, an approved CLOMR is required prior to beginning grading operations or receiving project approval at the Development Review Board or prior to Building Permit approval.
2. The lowest finished floor elevation is to be a minimum of 1 foot above the Base Flood Elevation (BFE).
3. An elevation certificate is required to be submitted to the Floodplain Administrator and deemed acceptable prior to obtaining a Certificate of Occupancy for the building. It is advised to follow-up with a LOMR-F or LOMA to remove the building from the flood zone.

## **ARTICLE 6-8 DOWNSTREAM CAPACITY AND OFFSITE FLOWS**

Downstream capacity and offsite flows are the most important elements of a successful drainage report/plan. The engineer is expected to research adjacent projects, as-built storm drain construction plans and Drainage Master Plans to correctly identify downstream capacity. See the Valley Drainage Criteria section if the project is in the valley.

Previously approved Drainage Masterplans can be relied upon as long as the basin conditions have not changed.

The engineer is also expected to perform a site visit, review topography and review adjacent drainage reports/plans to accurately identify offsite flows.

### **Part. 6-8(A) Downstream Capacity**

The drainage report/plan shall accurately state allowable downstream capacity. In the case, where the project is a small redevelopment project (less than 0.5 acres) and not in the valley, proposed flows not to exceed historic flows is most likely acceptable. Some small sites may have a history in which proposed flows will have to be less than historic flows.

### **Part. 6-8(B) Offsite Flows**

The drainage report/plan is to show the location and quantify offsite flows. In general, sites are to accept offsite flows and convey them safely to an acceptable outfall. A site may not have to accept offsite flows if a previously approved plan shows the outfall adjacent to the site and flows can be safely conveyed to an acceptable outfall.

### **Part. 6-8(C) Historic Flow Path through Adjacent Private Property**

If the only reasonable outfall for a proposed development is a historic flow path through an adjacent private property, the historic flow characteristics and path must be maintained.

## **ARTICLE 6-9 ENGINEERED CHANNELS AND NATURAL ARROYOS**

### **Part. 6-9(A) General Hydraulic Criteria**

In general, all open channels should be designed with the tops of the walls or levees at or below the adjacent ground to allow for interception of surface flows. If it is unavoidable to construct the channel without creating a pocket, a means of draining the pocket must be provided on the drawings. All local drainage should be completely controlled. External flows must enter the channel at designated locations and through designated inlets unless specifically otherwise authorized by the City Engineer.

### **Part. 6-9(B) Sharp Curves**

In making preliminary layouts for the routing of proposed channels, it is desirable to avoid sharp curvatures, reversed curvatures, and closely-spaced series of curves. If this is unavoidable, the design considerations below must be followed to reduce superelevations and to eliminate initial and compounded wave disturbances.

### **Part. 6-9(C) Maximum Froude Number**

It is generally desirable to design a channel for a Froude number of just under 2.0. In areas within the City of Albuquerque this is not always possible because of steep terrain. If the Froude number exceeds 2.0, any small disturbance to the water surface is amplified in the course of time and the flow tends to proceed as a series of "roll waves". Reference is made to sections below for criteria when designing a channel with a Froude number that exceeds 2.0.

In the design of a channel, if the depth is found to produce a Froude number between 0.7 and 1.3 for any significant length of reach, the shape or slope of the channel should be altered to secure a stable flow condition. All analyses should be performed for the 10-year and 100-year design discharges.

### **Part. 6-9(D) Water Surface Profile Calculations**

Water surface profile calculations must be calculated using the Bernoulli energy equation combined with the momentum equation for analyzing confluences and functions.

### Section. 6-9(D)(1) Determination of Controlling Water Surface Elevation

The following are generally control points for the calculation of the water surface profile:

1. Where the channel slope changes from mild to steep or critical, the depth at the grade break is critical depth.
2. Where the channel slope changes from critical to steep, the depth at the grade break is critical depth.
3. Where a discharging channel or conduit is on a mild slope, the water surface is generally controlled by the outlet.
4. When a channel on a steep slope discharges into a facility that has a water surface depth greater than the normal depth of the channel, calculate pressure plus momentum for normal depth and compare it to the pressure plus momentum for the water surface depth at the outlet according to the equation,  $P_n + M_n \sim P_o + M_o$ .
  - a. If  $P_n + M_n > P_o + M_o$ , this indicates upstream control with a hydraulic jump at the outlet.
  - b. If  $P_n + M_n < P_o + M_o$ , this indicates outlet control with a hydraulic jump probably occurring upstream.
  - c. Where the water surface of the outlet is below the water surface in the channel or conduit, control is upstream and the outflow will have the form of a hydraulic drop.

When there is a series of control points, the one located farthest upstream is used as a starting point for water surface calculation.

### Section. 6-9(D)(2) Direction of Calculation

Calculations proceed upstream when the depth of flow is greater than critical depth and proceed downstream when the depth of flow is less than critical depth.

### Section. 6-9(D)(3) Head Losses

#### 6-9(D)(3)(i) Friction Loss

Friction losses or open channels shall be calculated by an accepted form of the Manning equation. The Manning equation is commonly expressed as follows:

$$\text{EQUATION 7.22 } Q = (1.486/n) A R^{2/3} S_f^{1/2}$$

**where:**

**Q** = Flow rate, in c.f.s.

**n** = Roughness coefficient

**A** = Area of water normal to flow, in ft.<sup>2</sup>

**R** = Hydraulic radius

**S<sub>f</sub>** = Friction slope

when arranged into a more useful form:

$$S_f = (2gn^2/2.21((V^2/2g)/R^{4/3}))$$

the loss of head due to friction throughout the length of reach involved (L) is calculated by:



$$h_f = S_f L$$

Refer to the appendix for values of “n” for different materials and corresponding values of:  $(2gn^2/2.21)$

### 6-9(D)(3)(ii) [Junction Loss](#)

Junction losses will be evaluated by the pressure plus momentum equation and must conform to closed conduit angle of confluence criteria, [Section. 6-2\(B\)\(6\)](#). Refer to [Miscellaneous Hydraulic Calculations](#) later in this section.

## Section. 6-9(D)(4) Channel Inlets

### 6-9(D)(4)(i) [Side Channels](#)

Flow rates of 25% or more of the main channel flow must be introduced to the main channel by a side channel hydraulically similar to the main channel. The centerline radius of the side channel may not be less than the quantity  $(QV/100)$  in feet.

Velocity and depth of the flows in the side channel when introduced into the main channel must be matched to within 1 foot of velocity head and to within 20% of the flow depth for both the 10-year and 100-year design discharges and the four combinations of side inlet and main channel flows which result. Energy and momentum balance type calculations must be provided to support all designs involving side channels.

### 6-9(D)(4)(ii) [Surface Inlets](#)

When the main channel is relatively narrow and when the peak discharge of side inflow is in the range between 3 and 6 percent of the main channel discharge, high waves are usually produced by the side inflow and are reflected downstream for a long distance, thus requiring additional wall height to preclude overtopping of the channel walls. This condition is amplified when the side inflow is at a greater velocity than the main channel. To eliminate these wave disturbances, the Los Angeles District of the Corps of Engineers has developed a side channel spillway inlet. The City or AMAFCA may require this type of structure when outletting into one of their facilities, and its use should be considered for city channels if high waves above the normal water surface cannot be tolerated. See Subsection “f” below titled “Transitions” for the Corp’s procedure and criteria.

Surface-type inlets shall be constructed of concrete having a minimum thickness of 6 inches and shall be reinforced with the same steel as 6” concrete lining. The upstream end of the surface inlet shall be provided with a concrete cutoff wall having a minimum depth of three feet and the downstream end of the inlet shall be connected to the channel lining by an isolation joint. Side slopes of a surface inlet shall be constructed at slopes no greater than 1 vertical to 10 horizontal to allow vehicular passage across the inlet where a service road is required.

Drainage ditches or swales immediately upstream of a surface inlet shall be provided with erosion protection consisting of concrete lining, rock riprap or other non-erosive material.

Surface inlets shall enter the channel at a maximum of 90° to the channel centerline, i.e., they may not point upstream.

### 6-9(D)(4)(iii) Direct Pipe to Channel

Junctions involving direct pipe connection to a channel must conform to the criteria listed in the fifth section of the closed conduit criteria. Additionally, pipe and box culvert inlets to channels shall be isolated by expansion joints. Continuously reinforced channels shall be designed to accommodate any extra stress resulting from these discontinuities. [Paragraph 18\(h\), Corps of Engineers EM 1110-2-1061](#) has additional design criteria.

### 6-9(D)(4)(iii)(a) Transitions

#### 1. Subcritical Flow

- a. For subcritical velocities less than 12 f.p.s., the angle of convergence or divergence between the center line of the channel and the wall must not exceed 12° 30'. The length of the transition (L) is determined from the following equation:

$$\text{EQUATION 7.23 } L \geq 2.5 \Delta B$$

- b. For subcritical velocities equal to or greater than 12 f.p.s., the angle of convergence or divergence between the center line of the channel and the wall must not exceed 5° 45'. The length (L) is determined from the following equation:

$$\text{EQUATION 7.24 } L \geq 5.0 \Delta B$$

- c. Head losses for transitions with converging walls in subcritical flow conditions can be determined by using either the P + M method or the Thompson equation, both of which are shown in [Article 6-9 Street Hydraulics](#). For transitions, both methods are applicable in all cases and will give the same results.

#### 2. Supercritical Flow

##### a. Divergent Walls

- i The angle of divergence between the center line of the channel and the wall must not exceed 5° 45' or  $\tan^{-1}(F/3)$  whichever is smaller. The length of the transition (L) is the longest length determined from the following equations:

$$\text{EQUATION 7.25 } L \geq 5.0 \Delta B$$

$$\text{EQUATION 7.26 } L \geq 1.5 \Delta B * F$$

#### where:

**F** = Upstream Froude number based on depth of flow

**Δ B** = The difference in channel width at the water surface

- b. *Convergent Walls*
  - i *Converging walls should be avoided when designing channels in supercritical flow; however, if this is impractical, the converging transition will be designed to minimize wave action. The walls of the transition should be straight lines.*
- 3. *Transitions Between Channel Treatment Types*
  - a. *Earth Channel to Concrete Lining Transition*
    - i *The mouth of the transition should match the earth channel section as closely as practicable. Wing dikes and/or other structures must be provided to positively direct all flows to the transition entrance.*
    - ii *The upstream end of the concrete lined transition will be provided with a cutoff wall having a depth of 1.5 times the design flow depth, but at least 3.0 feet and extending the full width of the concrete section. Erosion protection directly upstream of the concrete transition consisting of grouted or dumped rock riprap at least 12 feet in length and extending full width of the channel section must be provided. Grouted riprap must be at least 12 inches thick and tied to the concrete lining and cutoff wall. Dumped riprap must be properly sized, graded and projected with gravel filter blankets.*
    - iii *The maximum allowable rate of bottom width transition is 1 to 7.5 maximum. Grout, dumped, or wire-tied material may also be used if approved on a case-by-case basis by the City Engineer. Grouted and wire-tied material require gravel filters as well.*
  - b. *Concrete Lining to Earth Channel Transition*
    - i *The transition from concrete lined channels to earth channels will include an energy dissipator as necessary to release the designed flows to the earth channel at a relatively non-erosive condition.*
    - ii *Since energy dissipator structures are dependent on individual site and hydraulic conditions, detailed criteria for their design is included in the section Criteria for Hydraulic Design of Closed Conduits. Minimum requirements are included herein for the concrete to earth channel transition.*
    - iii *On this basis, the following minimum standards govern the design of concrete to earth channel transitions. The maximum rate of bottom width transitions are:*

Water Velocity	
0 -15 f.p.s	1:10
16 - 30 f.p.s.	1:15
31- 40 f.p.s.	1:20

- iv *The downstream end of the concrete transition structure will be provided with a cutoff wall having a minimum depth of 4 feet and extending the full width of the concrete section.*
- v *Directly downstream of the concrete transition structure erosion protection consisting of rough, exposed surface, grouted rock riprap and extending full width of the channel section shall be provided. The grouted rock riprap should be a minimum of 12 inches thick and tied to concrete structure and the cutoff wall. Grout, dumped, or wire-tied material may also be used if approved on a case-by-case basis by the City Engineer. Grouted and wire-tied material require gravel filters as well. Riprap design criteria is presented in the ninth section.*

### Section. 6-9(D)(5) Bank Protection <sup>1</sup>

All berms and levees expected to convey or divert 30 cfs or more in the event of the 100-year design discharge must be provided with bank protection according to the following guidelines:

1. Bank protection must be provided wherever design velocities exceed 5 feet/sec.
2. Bank protection must be provided on the outside of curves from the beginning of curvature, through the curve and for a distance equal to 5 times the flow velocity in feet downstream from the point of tangency.
3. When required, bank protection must be provided to two feet above the design flow depth plus additional depth as required (e.g. superelevation, waves at confluences, hydraulic jumps, etc.).
4. Bank protection must extend downward on a projection of the bank slope, to a minimum depth equal to 1.5 times the design flow depth, but never less than 3.0 feet. Bank protection for major arroyos shall be accompanied by a City Engineer approved sediment transport analysis.

### Section. 6-9(D)(6) Piers

The effect of piers on open channel design must be considered at bridge crossings and where an open channel or box conduit not flowing full discharges into a length of multi-barreled box. This effect is especially important when flow is supercritical and when transported debris impinges on the piers.

The total pier width includes an added width for design purposes to account for debris. Inasmuch as the debris width to be used in design will vary with each particular situation, the City Engineer will be contacted during the preliminary design stages of a project for a determination of the appropriate width. Streamline piers should be used when heavy debris flow is anticipated. Refer to [Article 6-9 Street Hydraulics](#) for design data regarding streamline piers.

The water surface elevations at the upstream end of the piers is determined by equating pressure plus momentum. The water surface profile within the pier reach is determined by the Bernoulli equation. The water surface elevations at the downstream end of the piers may be determined by applying either the pressure plus momentum equation or the Bernoulli equation.

### Section. 6-9(D)(7) Curving Alignments

#### 6-9(D)(7)(i) [Superelevation](#)

Superelevation is the maximum rise in water surface at the outer wall above the mean depth of flow in an equivalent straight reach, caused by centrifugal force in a curving alignment.

#### 6-9(D)(7)(i)(a) [Rectangular Channels](#)

For subcritical velocity, or for supercritical velocity where a stable transverse slope has been attained by an upstream easement curve, the superelevation (S) can be calculated from the following equation:

<sup>1</sup> Berms, dams, levees, and diversions of certain magnitudes and nature may fall within the jurisdiction of the State Engineer of the State of New Mexico. The design professional is expected to be aware of and comply with regulations promulgated by that jurisdiction.

$$\text{EQUATION 7.27 } S = \frac{V^2 b}{2g r}$$

For supercritical velocity in the absence of an upstream easement curve, the superelevation (S) is given by the following equation:

$$\text{EQUATION 7.28 } S = \frac{V^2 b}{2g r}$$

**where:**

**V** = velocity of the flow cross section, in f.p.s.

**b** = Width of the channel, in ft.

**g** = Acceleration due to gravity

**r** = Radius of channel center line curve, in ft.

**X** = Distance from start of circular curve to point of first S in ft.

**D** = Depth of flow for an equivalent straight reach

**B** = Wave front angle

**where:**

$$X = (\pi b V) / ((12gD)^{0.5})$$

“S” will not be uniform around the bend but will have maximum and minimum zones which persist for a considerable distance into the downstream tangent.

### 6-9(D)(7)(i)(b) Trapezoidal Channels

For subcritical velocity, the superelevation (S) can be calculated from the following equation:

$$\text{EQUATION 7.29 } S = 1.15V^2 (b + 2 z D) / 2 g r$$

**where:**

**z** = cotangent of bank slope

**b** = channel bottom width, in ft.

For supercritical velocity, curving alignments shall have easement curves with a superelevation (S) given by the following equation:

$$\text{EQUATION 7.30 } S = 1.3V^2 (b + 2 z D) / 2 g r$$

### 6-9(D)(7)(i)(c) Unlined Channels

Unlined channels will be considered trapezoidal insofar as superelevation calculations are concerned. However, this does not apply to calculations of stream or channel cross-sectional areas.

### 6-9(D)(7)(ii) Easement Curves

Easement curves are alignment transition curves, employed upstream and downstream of circular curves, when supercritical flow exists in open channels. The purpose of the easement curve is to alter the transverse slope of the water surface and keep the water prism in constant static equilibrium against centrifugal force throughout the entire length of the easement curve and central circular curves, thus achieving minimum heights of superelevation with avoidance of cross-wave disturbances.

Circular easement curves are recommended in lieu of spiral transition curves for each of design and construction. Also very little hydraulic advantage is gained by the use of the spiral. The circular easement curve consists of curved sections upstream and downstream of the main curve having a radius (2R), twice the main curve radius (R).

### **6-9(D)(7)(ii)(a) Conditions Requiring Easement Curves**

1. When the freeboard, above superelevated water surface (as calculated without an easement curve), is less than two feet.
2. In reverse curves or on alignments where curves follow one another closely.
3. For any case where elimination of cross-wave disturbances is required. (If easement curves are not used, additional freeboard downstream of the curve may be necessary).
4. In trapezoidal channels for all cases of supercritical velocity.

### **6-9(D)(7)(ii)(b) Length of Easement Curve**

For rectangular channels, the length of easement curve ( $L_E$ ) is given by the following equation:

$$\text{EQUATION 7.31 } L_E = 2X = 0.32bVD^{0.5}$$

For trapezoidal and associated channel types, the length of easement curve ( $L_E$ ) can be calculated as follows:

$$\text{EQUATION 7.32 } L_E = 0.32 (b + 2zD) VD^{0.5}$$

Refer to the section on superelevation above for the definition of terms.

## **Section. 6-9(D)(8) Freeboard**

Freeboard is the additional wall height applied to a calculated water surface.

### **6-9(D)(8)(i) Rectangular Channels<sup>2</sup>**

1. For flow depths of 1.0 feet or less and average flow velocities less than 35 f.p.s., add 1.0 feet.
2. For flow depths of 1.0 feet or less and average flow velocities greater than 35 f.p.s., add 1.5 feet.
3. For flow depths of greater than 1.0 feet and average flow velocities of less than 35 f.p.s., add 2.0 feet.
4. For flow depths of greater than 1.0 feet and average flow velocities of greater than 35 f.p.s., add 3.0 feet.
5. For supercritical flow where the depth is between DC and 0.80 DC, the wall height must be equal to the sequent depth, but not less than the heights required above. This condition should be avoided.
6. Freeboard requirements for concrete drainage easement channels shall be established by the City Engineer on a case-by-case basis.

---

<sup>2</sup> Not used except with City Engineer approval.

### 6-9(D)(8)(ii) Trapezoidal Channels and Associated Types

Adequate channel freeboard above the designed water surface must be provided and will not be less than determined by the following:

1. For flow rates of less than 100 c.f.s. and average flow velocity of less than 35 f.p.s.:

$$\text{EQUATION 7.33 Freeboard (Feet)} = 1.0 + 0.025Vd^{1/3}$$

2. For flow rates of 100 c.f.s. or greater and average flow velocity of 35 f.p.s. or greater:

$$\text{EQUATION 7.34 Freeboard (Feet)} = 0.7 (2.0 + 0.025Vd^{1/3})$$

Freeboard will be in addition to any superelevation of the water surface, standing waves and/or other water surface disturbances. When the total expected height of disturbances is less than 0.5 feet, disregard their contribution.

Unlined portions of the drainage way may not be considered as freeboard unless specifically approved by the City Engineer.

For supercritical flow where the specific energy is equal to or less than 1.2 of the specific energy at  $D_c$ , the wall height will be equal to the sequent depth, but not less than the heights required above. This condition should be avoided.

### 6-9(D)(8)(iii) Roll Waves

Roll waves, sometimes known as slug flow, are intermittent surges on steep slopes that will occur when the Froude Number (F) is greater than 2.0 and the channel invert slope (S<sub>0</sub>) is greater than the quotient, twelve divided by the Reynolds Number. When they do occur, it is important to know the maximum wave height at all points along the channel so that appropriate wall heights may be determined based on the experimental results of roll waves by Richard R. Brock, the maximum wave height can be estimated.

## **Part. 6-9(E) Channel Design Criteria**

### **Section. 6-9(E)(1) Unlined Channels**

After full consideration has been given to the soil type, velocity of flow, desired life of the channel, economics, availability of materials, maintenance and any other pertinent factors, an unlined earth channel may be approved for use. Generally, its use is acceptable where erosion is not a factor and where mean velocity does not exceed 3 f.p.s. Old and well-seasoned channels will stand higher velocities than new ones; and with other conditions the same, deeper channels will convey water at a higher nonerodible velocity than shallower ones. Additional information is provided in [Article 6-9 Street Hydraulics](#).

Maximum side slopes are determined pursuant to an analysis of soil reports. However, in general, slopes should be 3:1 or flatter.

### Section. 6-9(E)(2) Composite Linings

In case part of the channel cross section is unlined or the linings are composed of different materials, a weighted coefficient must be determined using the roughness factors for the materials.

### Section. 6-9(E)(3) Maximum Sidewall Slopes

The following sidewall slopes are generally the maximum values used for channels on at least one side of the concrete lined channel. The road should be sloped away from the channel, and roadway runoff carried in a controlled manner to the channel.

<b>Lining Material</b>	<b>Maximum Slope</b>
Soil Cement	2:1
Portland Cement Concrete Vertical	2:1 (trapezoidal)
Grouted Rock Rip-Rap	2:1
Dumped Rock Rip-Rap	2:1
Earth Lined	3:1
Grass Lined (sodded)	4:1

### Section. 6-9(E)(4) Channel Maintenance and Access Road

A maintenance and access road having a minimum of 12 feet top width shall be provided on at least one side of improved channels. In some cases the City Engineer may require additional width. Channel maintenance and access roads shall, at a minimum, be surfaced with gravel base course. The thickness of said base course shall be 6 inches west of the Rio Grande, 4 inches east of the Rio Grande.

Turnouts will be provided at no more than ½ mile intervals and turnarounds must be provided at all access road dead ends.

Ingress and egress from public right-of-way and/or easements to the channel maintenance and access road must be provided.

### Section. 6-9(E)(5) Channel Access Ramps

Channel access ramps for vehicular use will be provided as necessary for complete access to the channel throughout its entire length with the maximum length of channel between ramps being one-half mile.

Ramps shall be constructed of 8" thick reinforced concrete and will not have slopes greater than 17% and ramps shall not enter the channel at angles greater than 15o from a line parallel to the channel centerline.

Ramps will be constructed on the same side of the channel as the maintenance and access road. The maintenance and access road shall be offset around the ramp to provide for continuity of the road full length of the channel.



The downhill direction of the ramp should be oriented downstream.

### **Section. 6-9(E)(6) Street Crossings**

Street crossing or other drainage structures over the concrete lined channel should be of the all weather type, i.e., bridges or concrete box culverts. Crossing structures should conform to the channel shape in order that they disturb the flow as little as possible.

It is preferred that the channel section be continuous through crossing structures. However, when this is not practicable, hydraulic disturbance shall be minimized, and crossing structures should be suitably isolated from the channel lining with appropriate joints.

Street crossing structures shall be capable of passing the 100 year frequency design storm flows.

Channel lining transitions at bridges and box culverts should conform to the provisions for transitions hereinafter provided. Drainage structures having a minimum clear height of 8 feet and being of sufficient width to pass maintenance vehicles may result in minimizing the number of required channel access ramps. Unless otherwise specifically authorized by the City Engineer, all crossing structures must have at least 6.0 feet of clear height.

### **Section. 6-9(E)(7) Subdrainage**

Concrete lined channels to be constructed in areas where the ground water table is greater than two feet below the channel invert, weep holes or other subdrainage systems are not required.

Areas where the ground water table is within two feet or less of the channel bottom, there shall be provided, special subdrainage systems as necessary to relieve water pressures from behind the channel lining.

### **Section. 6-9(E)(8) Channel bed width**

The minimum channel (soft or hard bottomed channels) bed width is 10 feet for publicly maintained channels.

## **Part. 6-9(F) Miscellaneous Hydraulic Calculations**

### **Section. 6-9(F)(1) Hydraulic Jump**

#### **6-9(F)(1)(i) Location**

If the water surface from a downstream control is computed until critical depth is reached, and similarly the water surface from an upstream control is computed until critical depth is reached, a hydraulic jump will occur between these

controls and the top of the jump will be located at the point where pressure plus momentum, calculated for upper and lower stages, are equal.

### 6-9(F)(1)(ii) Length

The length of a jump is defined as the distance between the point where roller turbulence begins and water becomes white and foamy due to air entrainment, and the point downstream where no return flow is observable.

1. For rectangular channels, the length of jump (L) for the range of Froude Numbers between two and twenty, based on flow depth, is given by the following equation:

$$\text{EQUATION 7.35 } L = 6.9 (D_2 - D_1)$$

**where:**

$D_1$  and  $D_2$  are the sequent depths.

2. For trapezoidal channels, the length of jump (L) is given by the following equation:

$$\text{EQUATION 7.36 } L = 5D_2(1+4(t_2-t_1/t_1)^{0.5})$$

**where:**

$t_1$  = width of water before jump

$t_2$  = width of water after jump

Side Slope	$L/(D_2-D_1)$
2:1	44.2
1:1	33.5
1/2:1	22.9
Vertical	6.9

### Section. 6-9(F)(2) **Trash Rack Head Loss**

The head loss through a trash rack is commonly determined from the following equation:

$$\text{EQUATION 7.37 } h_{TR} = K_{TR} (V_n/2_g)$$

$$\text{EQUATION 7.38 } K_{TR} = 1.45 - 0.45 (A_n/A_g) - (A_n/A_g)^2$$

**where:**

$K_{TR}$  = Trash rack coefficient

$A_n$  = Net area through bars, in ft.<sup>2</sup>

$A_g$  = Gross area of trash rack and supports (water area without trash rack in place), in ft.<sup>2</sup>

$V_n$  = Average velocity through the rack openings ( $A/A_n$ ), f.p.s.

For maximum head loss, assume that the rack is clogged, thereby reducing the value of  $A_n$  by 50%.

### Section. 6-9(F)(3) Side Channel Weirs:

The City or AMAFCA may require a side channel spillway inlet for drains out-letting into their facilities. The Corps' procedure for designing a side channel spillway is as follows:

1. Set the top of that part of the main channel wall at the location of the proposed spillway about 6 inches above the computed water surface level in the main channel.
2. Determine the length of spillway (L) required to discharge the design inflow of the side inlet by the following equation, in which the maximum value of H is not greater than one and one-half feet.

$$\text{EQUATION 7.39 } L = \frac{Q}{CH^{3/2}}$$

**where:**

**Q** = discharge of side inlet, in c.f.s.

**C** = weir coefficient

**H** = depth of water over the crest of the side inlet in feet

3. Determine the depth of flow in the approach side channel at the upstream end of the spillway.
4. Set the side channel invert elevation at the upstream end of the spillway at an elevation below the spillway crest a distance equal to the water depth as determined in c., above, minus the assumed head on the spillway.
5. Set the side channel invert slope equal to the spillway and the main channel water-surface slopes.
6. By trial, determine the width of the side channel required to maintain a constant depth of flow at several points downstream from the upstream end of the spillway. The discharge at each of these points is assumed to be the difference between the initial discharge less the amount spilled over that part of the spillway as computed by  $CLH^{3/2}$ , in which C is 3.087 and H is equal to the critical depth over the crest (neglecting the velocity of approach).
7. Plot the widths thus determined for the side channel on the channel plan and approximate a straight or curved line through them to locate the point of intersection of this line and the main channel wall.
8. If the length between the assumed point at the upstream end of the spillway and this intersection point is equal to the length determined in 2., above, the angle at the intersection indicates the required convergence for the side channel.
9. From the final layout determine the width and recompute the water surface in the side channel for the final design. The discharge over each portion of the spillway is calculated by using the average head between the two sections considered.

## Part. 6-9(G) Channel Treatment Selection Guidelines

### Section. 6-9(G)(1) General

The selection of a treatment type or of a combination of treatment types for a channel within the Albuquerque area should be based on a rational assessment of the needs of the community as they relate to:

### **Section. 6-9(G)(2) Flood Control**

The magnitude of the flood control requirements and the consequences of a system failure should be considered foremost in the treatment selection process.

### **Section. 6-9(G)(3) Drainage**

The existing and future land uses, the specific on- and off-site drainage treatments, and watershed topography should each be evaluated in terms of their impacts on the channel system. The unmitigated hydrologic effects of urbanization generally include higher peak runoff rates from small frequent storms, more frequent runoff events, cleaner runoff (with respect to sediment), and increased annual runoff volumes.

### **Section. 6-9(G)(4) Maintenance**

The selection of a channel treatment type should include analyses of both short and long term maintenance. While maintenance efforts will vary between treatment types, all facilities should be able to function through one runoff event with no maintenance, through one flood season with very little maintenance and from season to season with regular, but minimal maintenance requirements.

### **Section. 6-9(G)(5) Rights-of-Way and Easements**

The cost of land and the availability of rights-of-way or easements should be considered in the channel treatment selection process. Rights-of-way and easements should be appropriately located, aligned and sized for the particular treatment type. Some treatment types may require significant construction easements, but much smaller permanent rights-of-way or easements. The likelihood of replacement or reconstruction should be considered when channel treatment selection is balanced against the configuration of permanent rights-of-way and easements.

### **Section. 6-9(G)(6) Safety and Fence Requirements**

The selection of a channel treatment type should be based on any special safety considerations dictated by adjacent or nearby land uses. Whenever a required channel treatment is not compatible with adjacent land uses, adequate safety hazard mitigation measures should be incorporated into the design and construction of the facilities. Channels with vertical walls of 30 inches or greater will require a barrier or fence. Minimum fence or barrier height shall be 42 inches.

### **Section. 6-9(G)(7) Upstream and Downstream Channel Treatments**

The treatment selection process for each channel reach should include an analysis of the impacts of existing and planned upstream and downstream treatment types on a proposed treatment type and in turn the effects of the proposed treatment on existing and planned upstream and downstream treatments.

### **Section. 6-9(G)(8) Initial Cost and Life Expectancy**

The initial construction costs of various channel treatment types is, and will always be, one of the most heavily weighted factors in the selection process. However, when viewed on a larger scale, maintenance and replacement costs can be more important to the total costs of providing adequate levels of protection over time, and therefore must be considered in the planning, design and construction of channel treatment measures.

### **Section. 6-9(G)(9) Joint Use Possibilities**

The opportunities for including other uses such as transportation and utility corridors, open space or recreation in the design should be considered when selecting a treatment type and when establishing rights-of-way and easements. The inclusion of any other uses must be self-supporting financially and in no way impair or delay the implementation of the drainage and flood control function of the facilities.

### **Section. 6-9(G)(10) Sediment Transport and Channel Stability**

Moving water has the ability to transport sediment. The amount of sediment per unit of water that can be transported is related to flow depth, velocity, temperature, vertical and horizontal channel alignment, the amount of sediment available, the size and density of the sediment available and many other minor but sometimes important parameters. A channel's stability can be defined in terms of its ability to function properly during flood event without serious aggradation and/or degradation and that its continued operation can be relied upon without extraordinary maintenance and repairs. While channel stability problems are largely associated with earth and flexibly lined channels, concrete lined, supercritical channels are not immune. Any time a downstream channel reach has a lower sediment capacity than some upstream reach, there is a potential for sediment accumulation. The following worksheets can be used to make qualitative determinations with regard to channel stability.

Detailed qualitative analyses must be performed for any design requiring construction in a major arroyo. Methods found in items C.7 and C.8 in the Bibliography at the end of [Section. 6-2\(D\)\(2\)](#) shall be used in sediment transport analyses.

### **Section. 6-9(G)(11) Channel Stability**

A stable earth-lined channel is defined for the purposes of design as one in which neither degradation or aggradation is occurring at such a rate that it causes a continuous and serious maintenance problem. Channel degradation can cause extensive damage to bridges and other crossing structures due to the undermining of their foundations. Channel aggradation, on the other hand, results in reduced channel and crossing structure capacities and, therefore, in increased frequency of flooding.

**TABLE 6.9.14 Channel Stability Changes**

An increase or decrease in:	Will have the following effect in the channel:	
	Increase	Decrease
Flow Rate	Degradation	Aggradation
Flow Velocity	Degradation	Aggradation
Flow Frequency	Degradation	Aggradation
Flow Duration	Degradation	Aggradation
Flow Depth	Degradation	Aggradation
Sediment Reaching the Channel	Aggradation	Degradation
Sediment Particle Size	Aggradation	Degradation
Streambed Material Size	Aggradation	Degradation
Channel Vegetation	Aggradation	Degradation

### Section. 6-9(G)(12) Channel Construction Details

#### 6-9(G)(12)(i) [Earthwork](#)

The following shall be compacted to at least 90% of maximum density as determined by ASTM D-1557 (modified Proctor):

1. The 12 inches of subgrade immediately beneath concrete lining (both channel bottom and side slopes).
2. Top 12 inches of maintenance road. (either as subgrade or finished roadway if unsurfaced).
3. Top 12 inches of earth surface within 10 feet of concrete channel lip. It is particularly important to compact earth immediately adjacent to concrete lip. This area is sometimes overlooked when forms are removed.
4. All fill material.

#### 6-9(G)(12)(ii) [Concrete materials](#)

1. Cement type: IIA or I-IIIA
2. Minimum cement content: 5.5 sacks/c.y.
3. Maximum water-cement ratio: 0.53 (6 gals. per sack)
4. Maximum aggregate size: 1 ½ inches
5. Air content range: 4-7%
6. Maximum slump: 3 inches
7. Minimum compressive strength ( $f_c$ ): 3000 psi at 28 days
8. Class F Flyash meeting the requirements of ASTM C618 shall be proportioned in the mix at a 1:4 ratio of flyash to cement weight.
9. Steel reinforcement shall be grade 60 deformed bars. Wire mesh shall not be used.

#### 6-9(G)(12)(iii) [Concrete Lining](#)

1. Bottom width - 10 feet minimum
2. Side Slopes - 1 vertical to 2 horizontal maximum slope
3. Concrete lining thickness

All concrete lining shall have a minimum thickness of 6 inches. The lining shall be thickened to 7 inches on the channel bottom and lower 18 inches of the side slope. When design velocity exceeds 30 feet per second, the bottom section shall be thickened to 8 inches.

#### **6-9(G)(12)(iv) Concrete Finish**

The surface of the concrete lining shall be provided with a wood float finish. Precautions shall be taken to guard against excessive working or wetting of finish.

#### **6-9(G)(12)(v) Concrete Curing**

All concrete shall be cured by the application of liquid membrane-forming curing compound (white pigmented) immediately upon completion of the concrete finish.

#### **6-9(G)(12)(vi) Steps**

Ladder-type steps shall be installed at locations suitable for rescue operations along the channel but not farther than 700 ft. apart on both sides of the channel. Bottom rung shall be placed approximately 12 inches vertically above channel invert.

#### **6-9(G)(12)(vii) Joints**

1. Insofar as feasible, channels shall be continuously reinforced without transverse joints. However, expansion joints may be installed where new concrete lining is connected to a rigid structure or to existing concrete lining which is not continuously reinforced.
2. The preferred design avoids longitudinal joints. However, if included, longitudinal joints should be on side slope at least one foot vertically above channel invert.
3. All joints shall be designed to prevent differential displacement and shall be watertight.
4. Construction joints are normally appropriate at the end of a day's run, where lining thickness changes, and any time concrete placement stops for more than 45 minutes.

#### **6-9(G)(12)(viii) Reinforcing Steel for Continuously Reinforced Channels**

1. Ratio of longitudinal steel area to concrete area

$$A_{s \text{ long}} / A_{c \text{ long}} > 0.005$$

2. Ratio of transverse steel area to concrete area<sup>3</sup>

$$A_{s \text{ transv.}} / A_{c \text{ transv.}} > 0.0025$$

3. For steel Placement the temperature and shrinkage steel shall be placed so as to be in the top of the middle third of the slab, but at least 3" from the

---

**3** In (1) and (2) above  $A_s$  = crosssectional area of steel in the direction indicated;  $A_c$  = crosssectional area of concrete in the direction indicated. Longitudinal = long.; transverse = transv.

bottom of the slab. Longitudinal steel shall be on top of the transverse steel.

4

## ARTICLE 6-10 STREET HYDRAULICS

A secondary use of the street network is the conveyance of stormwater runoff. This secondary use must always be subsidiary to the primary function of streets which is the safe conveyance of people and vehicles. The goals of street hydraulic design are therefore:

1. To provide an economical means of transporting stormwater runoff.
2. To ensure that the safety and convenience of the public are preserved.
3. To prevent stormwater runoff, once collected by the street system, from leaving the street right-of-way except at specially designated locations.

### Part. 6-10(A) Street Hydraulic Design Criteria

Street hydraulic design criteria are as follows

1. Manning's roughness coefficient is 0.017.
2. The calculated HGL for the 100-year design discharge may not exceed curb height and the calculated EGL shall be contained within the street right-of-way.
3. For a sump condition, the HGL for the 100-year storm may extend to the street right-of-way.
4. For storm events less than or equal to the 10-year design discharge one lane free of flowing or standing water in each traffic direction must be preserved on arterial streets.
5. The product of depth times velocity shall not exceed 6.5 in any location in any street in the event of a 10-year design storm (with velocity calculated as the average velocity measured in feet per second and depth measured at the gutter flowline in feet.)
6. Gutter pan slope should be accommodated in the street cross-section.
7. The street cross section should be shown graphically. T-intersections, radical slope changes and intersections are potential locations for hydraulic jumps when upstream slopes are steeper than critical slope.
8. The assumption of equal flow distribution between gutters on undivided streets and between street sections on divided streets is only valid where its validity can be demonstrated.

### Part. 6-10(B) Option to Drain the Street to the Median

For arterial streets with a median, the street cross-section may be changed to drain the street in the median rather than to the outside edges of the roadway.

---

<sup>4</sup> Inspectors must insure this requirement is not violated by contractors during pouring operations.



## **Part. 6-10(C) Effects of Hydraulic Jump or Superelevation**

When conditions indicate that a hydraulic jump or that the effects of super-elevation will allow runoff to exceed street hydraulic design criteria, provisions must be made for treatment of the problem. The warping of street sections and the construction of deflector walls for these purposes is prohibited unless specifically authorized by the City Engineer.

## **Part. 6-10(D) Intersection**

Intersections and other radical changes in street cross section and slope require special consideration whenever the flow depth/street slope relationship results in flows occurring in the supercritical flow regime. The critical slope line shown on the street rating curves is used to determine on which side of critical depth the flow occurs and if slope or cross section changes will allow the flow to cross through critical depth from supercritical. If flow is likely to cross into the subcritical flow range, the height and length of hydraulic jump must be demonstrated in the drainage report.

## **Part. 6-10(E) Drainage Design Criteria in Street Design.**

1. Nuisance flows will not be conveyed across arterial or collector streets on the surface by valley gutters or other means. Valley gutters conveyance of nuisance flows across major local streets is discouraged. Provisions for storm drainage inlets to meet this requirement must be included at all intersections of major streets (collector or above) as defined by the Long Range Roadway System Plan.
2. The use of quarter point crown (i.e. high point of crown at mid-lane on high side of street) is preferred over the use of full side-hill street configuration to prevent sheet flow across pavement surfaces.
3. Transitional pavement surface approaches to intersections must be designed to contain nuisance flows within gutter lines; valley gutters must be provided to accommodate flows across intersections suitably, parallel to the major traffic carrying street.
4. Arterial, collector and sole access streets to subdivisions may not employ at-grade or dip section crossings of arroyos. Specific criteria for design of these crossings is given in [Chapter 6](#).
5. For undesignated roadways, valley gutters will be required to convey flows across the roadway.
6. Dip or overflow sections will only be permitted on local streets with the approval of the Traffic Engineer and the City Engineer.
  - a. *Dip or overflow sections may only be used where the depth of flow times the velocity of flow over the roadway including sidewalks will not exceed 6.5 for that portion of the 10-year storm runoff crossing over the street. Velocity is to be calculated as the velocity measured in feet per second and the flow depth is to be measured in feet at the upstream edge of the roadway including sidewalk.*

- b. If dip sections are permitted, vertical alignment must satisfy the requirements in [Chapter 7](#) for sight distances considering the design speed of the street in question.

## **Part. 6-10(F) Inlet Placement and Design Criteria**

Inlets should be placed to meet the street flow criteria discussed above. Size and type of inlets should be determined by physical requirements and by grate and flow capacities given in [Plates 22.8 D-1](#) and [22.8 D-2](#), inclusive. Criteria used, if other than those recommended in this section, must be cited and accompanied by appropriate calculations. Inlet spacing should be per [Plate 22.8 D-3](#).

### **Section. 6-10(F)(1) Standard Inlets**

The selection of type, number, and spacing of inlets should be based on Plates 22.8 D-1 through 22.8 D-4 and the following instructions. A bicycle safe grate should be used with "Type A and C inlets".

City standard inlets "Type A, Type B and C" are combination inlets with both curb opening and grates. Inlet "Type D" is a grate only inlet. Inlet gratings tend to accumulate debris and clog. The curb opening both limits debris accumulation and offsets lost capacity due to clogging of the grating. Except for certain valley applications, combination inlets should be used. Due to main line clogging, grating only inlets should be used in valley applications where main line pipe diameters are 24" or less or where quarter full pipe velocities are less than 2.5 f.p.s.

"Type A" inlets should be used for single basin applications and as the first basin in a battery of basins. The "Type A" inlet performs the function of sweeping debris of the street upstream of the grating and minimizing clogging. "Type A" inlets are used with standard 8" curb and gutter. The capacity is shown in Plates 22.8 D-.1

"Type B" inlets are generally placed downstream of and/or in conjunction with "Type A" inlets on streets other than arterials and collectors. This inlet type has potential to collect substantial runoff when the grating is clean. If "Type B" inlets are used alone, without a "Type A" within 150 feet upstream, the capacity shown in Plate 22.8 D-3 should be reduced by 15% due to clogging. "Type B" inlets are used with standard 8" curb and gutter. A bicycle safe grate shall be used with a "Type B" inlet.

"Type C" inlets are generally placed downstream of and/or in conjunction with "Type A" inlets. If "Type C" inlets are used without a "Type A" within 150 feet upstream, the capacity shown in Plates 22.8 D-1 and 22.8 D-2 should be reduced 15% for clogging. "Type C" inlets are used with standard 8" curb and gutter.

"Type D" inlets are generally used on streets with slope greater than 5%, in driveways and in certain valley areas as described above. "Type D" inlets can be used with either standard 8" curb and gutter or with mountable curb. The capacity shown in Plates 22.8 D-1 and 22.8 D-2 should be reduced 15% for clogging.

The number of inlets to be connected in series should not exceed two. If the connection of more than two catch basins in series is unavoidable, consideration should be given to designing a lateral drain.

The capacity of the lateral storm drain is to be considered when placing inlets as the grate capacity may be limited by the lateral storm drain.

If there is a conflict with an existing Type "A" or "C" inlet with a proposed plan the following criteria should apply:

1. The conversions of type A's, or C's to Type D inlets will be permitted if a throated inlet is within 150 feet upstream.
2. If there is not a throated inlet within 150 feet upstream, the conversions of Type A's, or C's to Type D inlets will be permitted if a throated inlet is added within 150 feet upstream.
3. Or the inlet shall be removed and replaced with an inlet outside the conflict zone.
4. The inlet can be removed and replaced with a Type Double-D inlet

The engineer should verify there is adequate clearance for proposed driveways near inlets. If an apparent conflict exists the proposed driveways near inlets should be shown on the grading plan and shall be shown on the DRC construction plans.

If there is a conflict with a Type "B" or cattle guard inlet, the inlet is to be removed and replaced outside the conflict zone.

FIGURE 6.10.8 Grating Capacities for Type "A", "C", and "D"

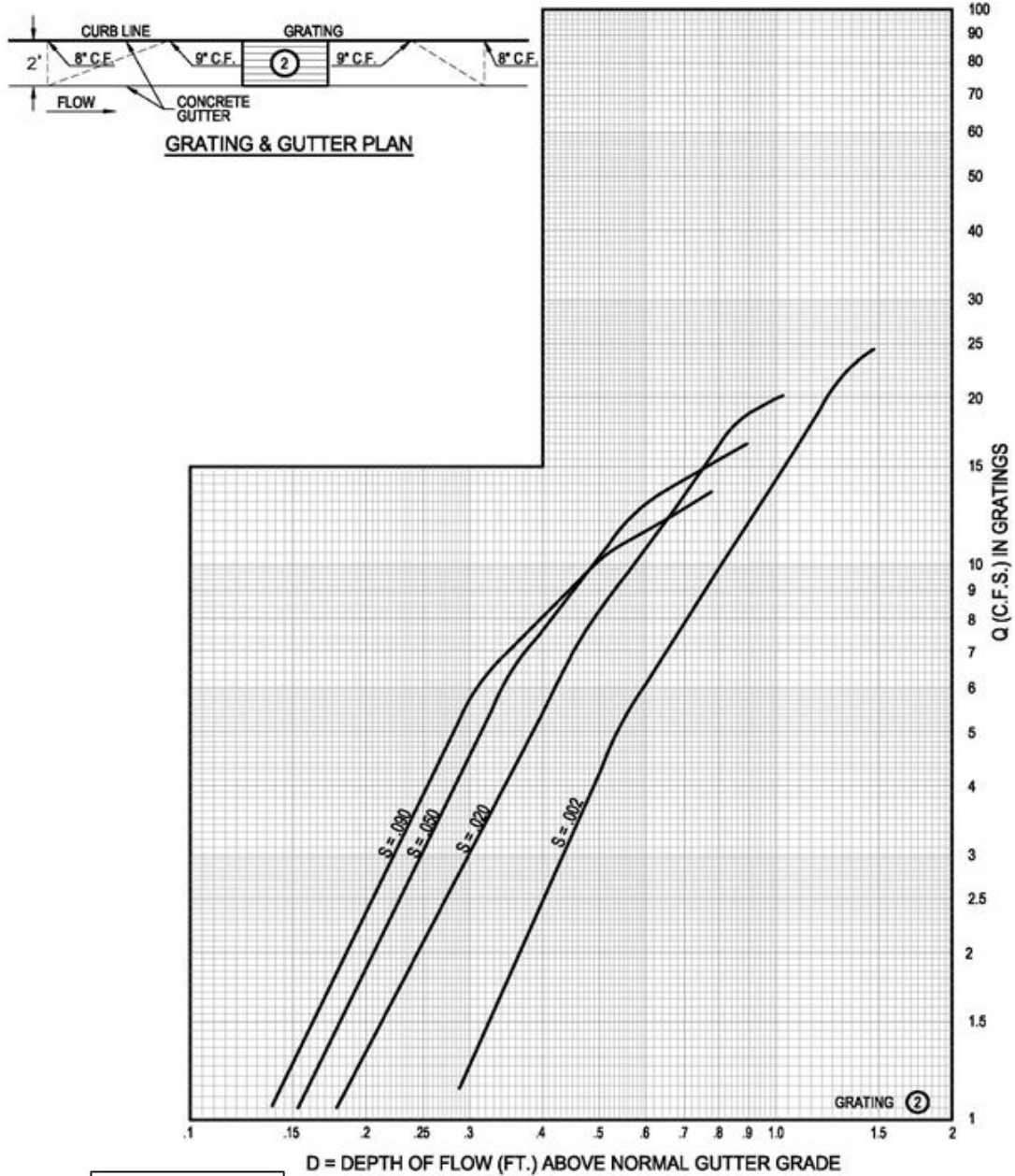


Plate 22.8 D-1

FIGURE 6.10.9 Grating Capacities for Type Double "C", "D", and "A"

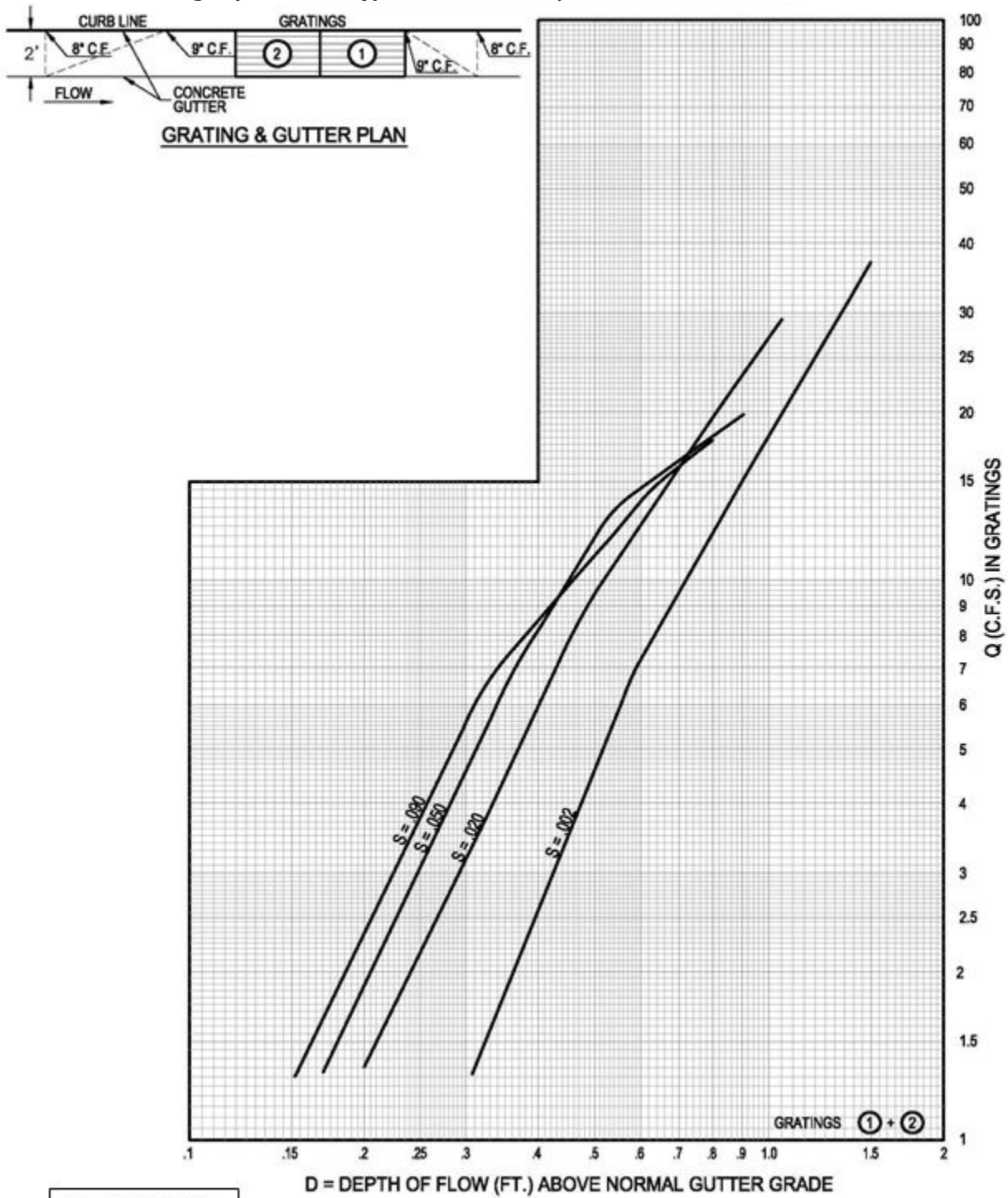
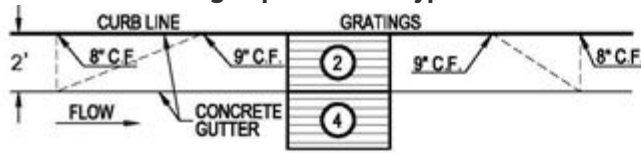


Plate 22.8 D-2



FIGURE 6.10.10 Grating Capacities for Type B



GRATING & GUTTER PLAN

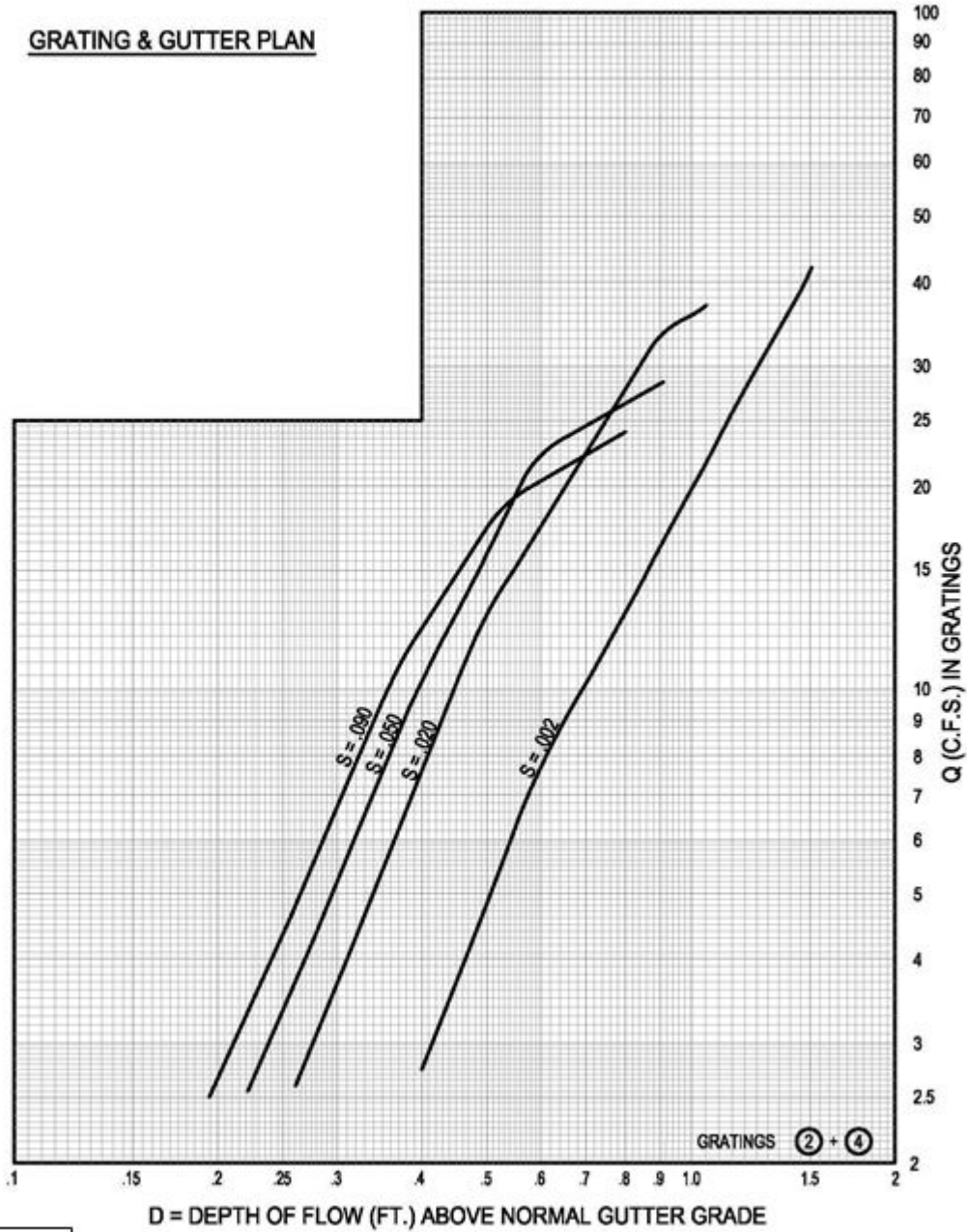


Plate 22.8 D-3

FIGURE 6.10.11 Optimum Spacing of Catch Basins on a Continuous Grade

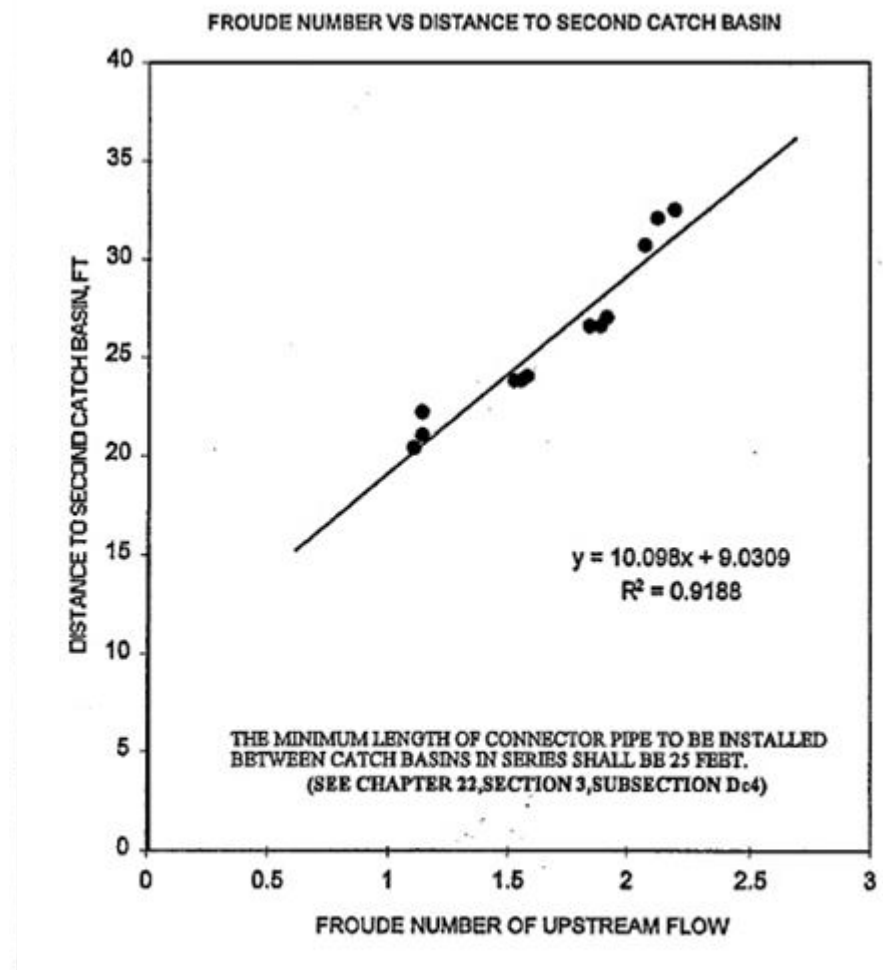


Plate 22.8 D-4

**Section. 6-10(F)(2) Cattle-Guard and Median inlets**

Standard drawings are available for cattle-guard and median inlets. Plates presented earlier in this section were for the capacity of Type A, C and D inlets. The engineer shall provide calculations for capacity when proposing cattle-guard and median inlets. A bicycle safe grate shall be used with a cattle-guard inlet.

**Section. 6-10(F)(3) Publicly-Maintained Inlets To Be Located Within Street Rights-of-Way**

Inlets will be located within street rights-of-way unless otherwise approved by the City Engineer. Inlets located outside of Right-of-way require an easement with beneficiary and maintenance responsibilities defined.

Construction of inlets that will be located outside constructed streets to accommodate future street widenings is discouraged. However, the lateral storm drain stub shall be constructed past the permanent pavement section.

Inlets to be constructed off the paved portion of the roadway but within the street property lines must be made operable by grading the roadway to permit storm water to flow to the inlet. The area around the inlet shall be adequately protected from erosion and sedimentation.

### **Section. 6-10(F)(4) Inlets in a Sump Condition**

Sump designs for should normally be limited to local streets and only those situations where terrain or grading considerations warrant their use. When specifying a sump inlet(s) the designer shall ensure that surrounding properties are protected from the occurrence of inlet and lateral clogging by demonstrating that one of the following emergency backup conditions exist:

1. The design storm peak flow rate will release to either a public R.O.W. or public easement without rising above any adjacent structure pad elevations.
  - a. *When relying on public easements across private property for this option, the easement language creating the encumbrance shall specify that said easement is a Public Drainage Easement and no structural improvements which would interfere with conveyance or storage of water shall be allowed. Any surface modification within the drainage easement will require an encroachment agreement from the City.*
  - b. If the subdivision or street network design does not lend itself to releasing the drainage as stated above, it is acceptable to double the number of sump inlets. The additional inlet(s) are an emergency overflow in case the inlet(s) required to carry the peak flow are clogged.
2. Sufficient storage is available within a combination of public R.O.W., public easement, to hold 100% of the design event volume, without inflicting damage to structures.

## **Part. 6-10(G) Inlet Lateral and Connector Pipe Capacity**

When designing inlets to capture stormwater from the street, the capacity of the lateral (pipe connecting inlet to main line) pipe and the capacity of connector (inlet to inlet) pipes must be determined. Calculations are to be included in the drainage report or plan.

The capacity can be shown with gravity flow using manning's equation or by pressure flow using an acceptable modelling program. The program must meet the following criteria to be accepted:

1. Be able to produce an illustration of the HGL and EGL.
2. Have the ability to include major and minor losses.
3. Meet technical requirements of this chapter.
4. If requested by the City Engineer, the design engineer shall provide a description of how the model meets the requirements of this chapter.



### **Section. 6-10(G)(1) Connector and Lateral Pipe Criteria**

1. The minimum diameter of connector and lateral pipes is 18 inches.
2. The horizontal alignment of lateral and connector pipes must not contain angle points or bends, unless approved by the City Engineer.
3. Lateral connections to the main line are preferred at manholes or junction structures. Exceptions to this criterion must be approved by the City Engineer. Lateral pipes connecting to a main line from both sides of a street (not using a manhole) should be offset 8 feet or more at the main line and require City Engineer approval.
4. The inlet spacing shall be a minimum of 30 feet center of downstream grate to center of upstream grate.
5. Catch basin connector pipes shall outlet at the downstream end of the catch basins, unless prevented by field conditions. Downstream, in this paragraph, refers to the directions of the gutter slope at the catch basin in question.

### **Section. 6-10(G)(2) Consideration of Existing Drainage Systems During Construction**

Existing drainage systems which are not required to carry any portion of the design Q of a proposed system may be designated to be abandoned in place upon completion of the proposed drain. Such existing drainage systems should not be sealed or removed before completion of the proposed system, if needed to carry off storm water during the construction period. It is the designer's responsibility to ascertain the necessity of maintaining existing drainage systems in place.

Existing street or sidewalk culverts may be designated to have the interfering portions removed and the inlets sealed, or the culverts may be kept in operation and connected to the storm drain or to the back of a proposed catch basin. If the culvert is to be connected, a structural detail should be provided. Refer to the City Engineer for instructions.

Existing street or sidewalk culverts that do not interfere with construction should be maintained in place.

If the existing culvert is located in, or its required to drain a sump, the designer should make every effort to avoid removal of the culvert, especially in instances where the capacity of the proposed drain is less than that required for the correct design frequency.

## **ARTICLE 6-11 CRITERIA FOR HYDRAULIC DESIGN OF CLOSED CONDUITS**

### **Part. 6-11(A) General Hydraulic Criteria**

Closed conduit sections (pipe, box or arch sections) will be designed as flowing full and, whenever possible, under pressure except when the following conditions exist:

1. In some areas of high sediment potential, there is a possibility of stoppage occurring in drains. In situations where sediment may be expected, the City Engineer must be consulted for a determination of the appropriate bulking factor.
2. In certain situations, open channel sections upstream of the proposed closed conduit may be adversely affected by backwater.

If the proposed conduit is to be designed for pressure conditions, the hydraulic grade line shall not be higher than the ground or street surface, or encroach on the same in a reach where interception of surface flow is necessary. However, in those reaches where no surface flow will be intercepted, a hydraulic grade line which encroaches on or is slightly higher than the ground or street surface will be acceptable provided that pressure manholes exist or will be constructed.

### **Part. 6-11(B) Hydraulic Grade Line Calculations**

#### **Section. 6-11(B)(1) Determination of Control Water Surface Elevation**

A conduit to be designed for pressure conditions may discharge into one of the following:

1. A body of water such as a detention reservoir
2. A natural watercourse or arroyo
3. An open channel, either improved or unimproved
4. Another closed conduit

The controlling water surface elevation at the point of discharge is commonly referred to as the control and, for pressure flow, is generally located at the downstream end of the conduit. If flow becomes unsealed, the control may be at the first grade break upstream of the point where unsealing occurs or, under certain conditions, may be farther upstream.

Two general types of controls are possible for a conduit on a mild slope, which is a physical requirement for pressure flow in discharging conduits.

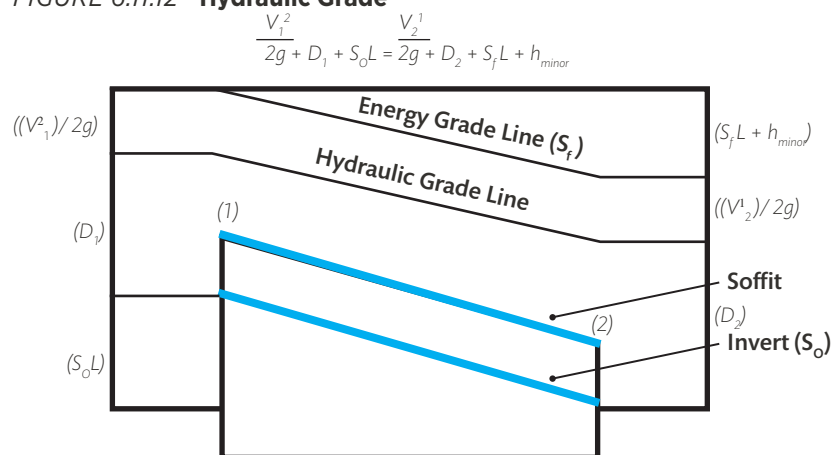
1. Control elevation above the soffit elevation. In such situations, the control must conform to the following criteria:
  - a. *In the case of a conduit discharging into a detention facility, the control is the 10-year water surface reservoir elevation.*

- b. In the case of a conduit discharging into an open channel, the control is the 10-year design water surface elevation of the channel.
  - c. In the case of a conduit discharging into another conduit, the control is the design hydraulic grade line elevation of the outlet conduit immediately upstream of the confluence.
    - i. Whenever case (a) or (b) above is used, the possibility of having flow out of manholes or inlets due to discharge elevations at the 100-year level must be investigated and appropriate steps taken to prevent its occurrence.
2. Control elevation at or below the soffit elevation. The control is the soffit elevation at the point of discharge. This condition may occur in any one of the four situations described above in 2a.

## Part. 6-11(C) Instructions for Hydraulic Calculations

Most procedures for calculating hydraulic grade line profiles are based on the Bernoulli equation. This equation can be expressed as follows:

FIGURE 6.11.12 Hydraulic Grade



**where:**

- D** = Vertical distance from invert to H.G.L.
- S<sub>o</sub>** = Invert slope
- L** = Horizontal projected length of conduit
- S<sub>f</sub>** = Average friction slope between Sections 1 and 2
- V<sub>g</sub>** = Average velocity (g/A)
- h<sub>minor</sub>** = Minor head losses

Minor losses have been included in the Bernoulli equation because of their importance in calculating hydraulic grade line profiles and are assumed to be uniformly distributed in the above figure.

When specific energy (E) is substituted for the quantity (V<sup>2</sup>/2g + D) in the above equation and the result rearranged,

EQUATION 7.40  $L = \frac{E_2 - E_1}{S_o - S_f}$

$$S_o - S_f$$

The above is a simplification of a more complex equation and is convenient for locating the approximate point where pressure flow may become unsealed.

## Section. 6-11(C)(1) Head Losses

### 6-11(C)(1)(i) Friction Loss

Friction losses for closed conduits carrying storm water, including pump station discharge lines, will be calculated from the Manning equation or a derivation thereof. The Manning equation is commonly expressed as follows:

$$\text{EQUATION 7.41 } Q = \frac{1.486 AR^{2/3} S_f^{1/2}}{n}$$

**where:**

**Q** = Discharge, in c.f.s.

**n** = Roughness coefficient

**A** = Area of water normal to flow in ft.<sup>2</sup>

**R** = Hydraulic radius

**S<sub>f</sub>** = Friction slope

when rearranged into a more useful form:

$$S_f = [Q_n / 1.486 AR^{2/3}]^2 = [Q/K]^2$$

**where:**

$$K = \frac{1.486 AR^{2/3}}{n}$$

The loss of head due to friction throughout the length of reach (L) is calculated as follows:

$$h_r = S_f L = [Q/K]^2 L$$

The value of K is dependent upon only two factors: the geometrical shape of the flow cross section as expressed by the quantity (AR<sup>2/3</sup>), and the roughness coefficient (n). The values of n are shown in [Section 16](#).

### 6-11(C)(1)(ii) Transition Loss

Transition losses will be calculated from the equations shown below.

For a Contraction (increasing velocity):

$$\text{EQUATION 7.42 } H_f = K_c / 2 (V_2 - V_1)^2 / 2g$$

For an Expansion (decreasing velocity):

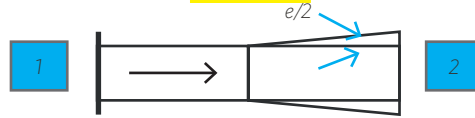
$$\text{EQUATION 7.43 } H_f = K_e (V_2 - V_1)^2 / 2g$$

where:

$$K_e = 3.50(\tan \varnothing/2)^{1.22}$$

These equations are applicable when no change in Q occurs and where the horizontal angle of divergence or convergence ( $\varnothing/2$ ) between the two sections does not exceed 5 degrees 45 minutes.

FIGURE 6.11.13 **Need Title**



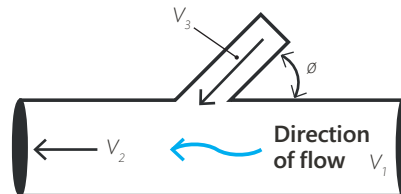
Deviations from the above criteria must be approved by the City Engineer. When such situations occur, the angle of divergence or convergence ( $\varnothing/2$ ) may be greater than 5 degrees 45 minutes. However, when it is increased beyond 5 degrees 45 minutes, the above equation will give results for hf that are too small, and the use of more accurate methods, such as the Gibson method shown, wherein  $K_e = 3.50(\tan \varnothing/2)^{1.22}$ .

### 6-11(C)(1)(iii) Junction Losses

In general, junction losses are calculated by equating pressure plus momentum through the confluences under consideration. This can be done by using either the P + M method or the Thompson equation, both of which are shown in the [Article 6-8](#). Both methods are applicable in all cases for pressure flow and will give the same results.

For the special case of pressure flow with  $A_1 = A_2$  and friction neglected,

FIGURE 6.11.14 **Junction Losses**



### 6-11(C)(1)(iv) Manhole Loss

Manhole losses will be calculated from the equation shown below. Where a change in pipe size and/or change in Q occurs, the head loss will be calculated in accordance with [Article Article 6-7 Downstream Capacity and Offsite Flows](#) and [Article 6-8 Engineered Channels and Natural Arroyos](#), preceding.

EQUATION 7.44  $H_{mh} = 0.05(V^2/2g)$

### 6-11(C)(1)(v) Bend Loss

Bend losses should be included for all closed conduits, those flowing partially full as well as those flowing full. Bend losses will be calculated from the following equation:

EQUATION 7.45  $H_b = K_b(V^2/2g)$

where:

$K_b = 0.20(\theta/90^\circ)^{0.5}$

where:

$\theta$  = central angle of bend in degrees

### 6-11(C)(1)(vi) [Exit Loss](#)

Exit loss is the loss when storm drains daylight into a pond or channel, the loss associated with this condition is:

EQUATION 7.46  $h_{\text{exit}} = 0.25(V^2/2g)$

### 6-11(C)(1)(vii) [Transition to Smaller Pipe Size](#)

As a general rule, storm drains will be designed with sizes increasing in the downstream direction. However, when studies indicate it may be advisable to decrease the size of a downstream section, the conduit may be decreased in size with the approval from the City Engineer.

## **Part. 6-11(D) Design Requirements for Maintenance and Access**

### Section. 6-11(D)(1) **Manholes**

#### 6-11(D)(1)(i) [Spacing](#)

Manholes should be spaced at intervals of approximately 450 feet. Where the proposed conduit is less than 30 inches in diameter and the horizontal alignment has numerous bends or angle points, the manhole spacing should be reduced to approximately 300 feet.

The spacing requirements shown above apply regardless of design velocities. Deviations from the above criteria are subject to City Engineer approval.

#### 6-11(D)(1)(ii) [Location](#)

Manholes should not be located in street intersections, especially when one or more streets are heavily traveled. In situations where the proposed conduit is to be aligned both in easement and in street right-of-way, manholes should be located in street right-of-way, wherever possible.

Manholes should be located as close to changes in grade as feasible when the following conditions exist:

1. When the upstream conduit has a steeper slope than the downstream conduit and the change in grade is greater than 10 percent, sediment tends to deposit at the point where the change in grade occurs.
2. When transitioning to a smaller downstream conduit due to an abruptly steeper slope downstream, sediment tends to accumulate at the point of transition.

3. When the design flow in a pipe flowing full has a velocity of 20 f.p.s. or greater, or is supercritical in a partially full pipe, the total horizontal angle of divergence or convergence between the walls of the manhole and its center line should not exceed 5°45'.

### **Section. 6-11(D)(2) Pressure Manholes**

A pressure manhole shaft and a pressure frame and cover will be installed in a pipe or box storm drain whenever the design water surface is more than 0.2 feet above the ground surface. Pressure manholes should only be used when a non-pressure manhole solution is unavoidable.

### **Section. 6-11(D)(3) Special Manholes**

Special 36-inch diameter manholes or vehicular access structures will be provided when required. The need for access structures will be determined by the City Engineer during the review of preliminary plans.

### **Section. 6-11(D)(4) Deep Manholes**

A manhole shaft safety ledge will be provided in all instances when the manhole shaft is 20 feet or greater in depth. Installation will be in accordance with City Engineer requirements.

### **Section. 6-11(D)(5) Bends**

Field fabricated bends are not allowed. Bends must be pre-manufactured and have access within 3' for pipes smaller than 36" and within 8' for larger pipes. Construction plans must specify the station, offset, elevation, and deflection angle of each bend. Specifications must be included with the drainage calculations submitted to hydrology prior to approval of the work order plans and the specifications must be on the plans. Bends must conform to manufacturer specifications as submitted.

### **Section. 6-11(D)(6) Curvilinear Storm Drain**

Curvilinear storm drains are allowed but should be avoided where possible. Only horizontal curves will be allowed, vertical curves are not allowed. Only one radius may be used between manholes so a manhole must be located at points of reverse curvature and/or compound curvature, but a tangent is allowed on both sides of a curve provided that other manhole spacing criteria is also adhered to. Minimum slopes shall be increased by 10% for curvilinear storm drains and no grade breaks will be allowed between manholes. Pipe and gasket manufacturer specifications clearly identifying pipe length, maximum deflection angle, and minimum radius must be included with the drainage calculations submitted to hydrology prior to approval of the work order plans and must be specified on the plans. Curvilinear storm drains must conform to manufacturer specifications as submitted.

## **Part. 6-11(E) Closed Conduit Pipe Size and Slope**

### **Section. 6-11(E)(1) Minimum Pipe Size**

In cases where the conduit may carry significant amounts of sediment (greater than 8%), the minimum diameter of main line conduit will be 36 inches. In situations where sediment may be expected, the City Engineer will be consulted to determine the applicability of sediment criteria.

### **Section. 6-11(E)(2) Minimum Slope**

Unless otherwise approved by the City Engineer, the minimum slope for main line conduit will be .004 (.40 percent). Minimum flow velocity for the 10-year design flow will be 3 f.p.s.

## **Part. 6-11(F) Earthen Channels to Storm Drain Structures**

An inlet structure will be provided for storm drains located in natural channels. The structure should generally consist of a headwall, wingwalls to protect the adjacent banks from erosion, and a paved inlet apron or rip-rap. The apron slope should be limited to a maximum of 2:1. Wall heights should conform to the height of the water upstream of the inlet, and be adequate to protect both the fill over the drain and the embankments. Headwall and wing-wall fencing and a protection barrier to prevent public entry will be provided.

If trash and debris are prevalent, barriers consisting of vertical 3-inch or 4-inch diameter steel pipe at 24 inches to 36 inches on centers should be embedded in concrete immediately upstream of the inlet apron. Trash rack designs must have City Engineer approval.

## **Part. 6-11(G) Storm Drain Outlets to Public Earthen Arroyos and Ponds**

When a storm drain outlets into an earthen arroyo, an outlet structure will be provided which prevents erosion and property damage. Fencing and a protection barrier will be provided where deemed necessary by the City Engineer.

The outlet structure shall have an end treatment and design that minimizes erosion. The following design criteria was adopted from "[Urban Storm Drainage Criteria Manual Volume 2](#)" from the Urban Drainage and Flood Control District, Denver, Colorado, June 2001, revised April 2008.

### **Section. 6-11(G)(1) Incorporation of "Urban Storm**



## Drainage Criteria Manual Volume 2” from the Urban Drainage and Flood Control District, Denver, Colorado

Energy dissipation or stilling basin structures are required to minimize scour damage caused by high exit velocities and turbulence at conduit outlets. Similarly, culverts nearly always require special consideration at their outlets. Outlet structures can provide a high degree of energy dissipation and are generally effective even with relatively low tailwater control. Rock protection at conduit outlets is appropriate where moderate outlet conditions exist; however, there are many situations where rock basins are impractical. Reinforced concrete outlet structures are suitable for a wide variety of site conditions. In some cases, they are more economical than larger rock basins, particularly when long-term costs are considered.

Any outlet structure must be designed to match the receiving stream conditions. The following steps include an analysis of the probable range of tailwater and bed conditions that can be anticipated including degradation, aggradation, and local scour.

Hydraulic concepts and design criteria are provided in this section for an impact stilling basin and adaptation of a baffle chute to conduit outlets. Use of concrete is often more economical due to structure size or local availability of materials. Initial design selection should include consideration of a conduit outlet structure if any of the following situations exist:

1. high-energy dissipation efficiency is required where hydraulic conditions approach or exceed the limits for alternate designs;
2. low tailwater control is anticipated; or
3. site conditions, such as public use areas, where plunge pools and standing water are unacceptable because of safety and appearance, or at locations where space limitations direct the use of a concrete structure.

Longer conduits with large cross-sectional areas are designed for significant discharges and often with high velocities requiring special hydraulic design at their outlets. Here, dam outlet and spillway terminal structure technology is appropriate (USBR 1987). Type II, III or IV stilling basins, submerged bucket with plunge basin energy dissipators and slotted-grating dissipators can be considered when appropriate to the site conditions. For instance, a plunge basin may have applicability where discharge is to a wet detention or retention pond.

### 6-11(G)(1)(i) [Impact Stilling Basins](#)

Most design standards for an impact stilling basin are based on the USBR Type VI basin, often called “impact dissipator” or conduit “outlet stilling basin”. This basin is a relatively small structure that is very efficient in dissipating energy without the need of tailwater. The original hydraulic design reference by Biechly (1971) is based on model studies. Additional structural design details are provided by Aisenbrey, et al. (1974) and Peterka (1984).

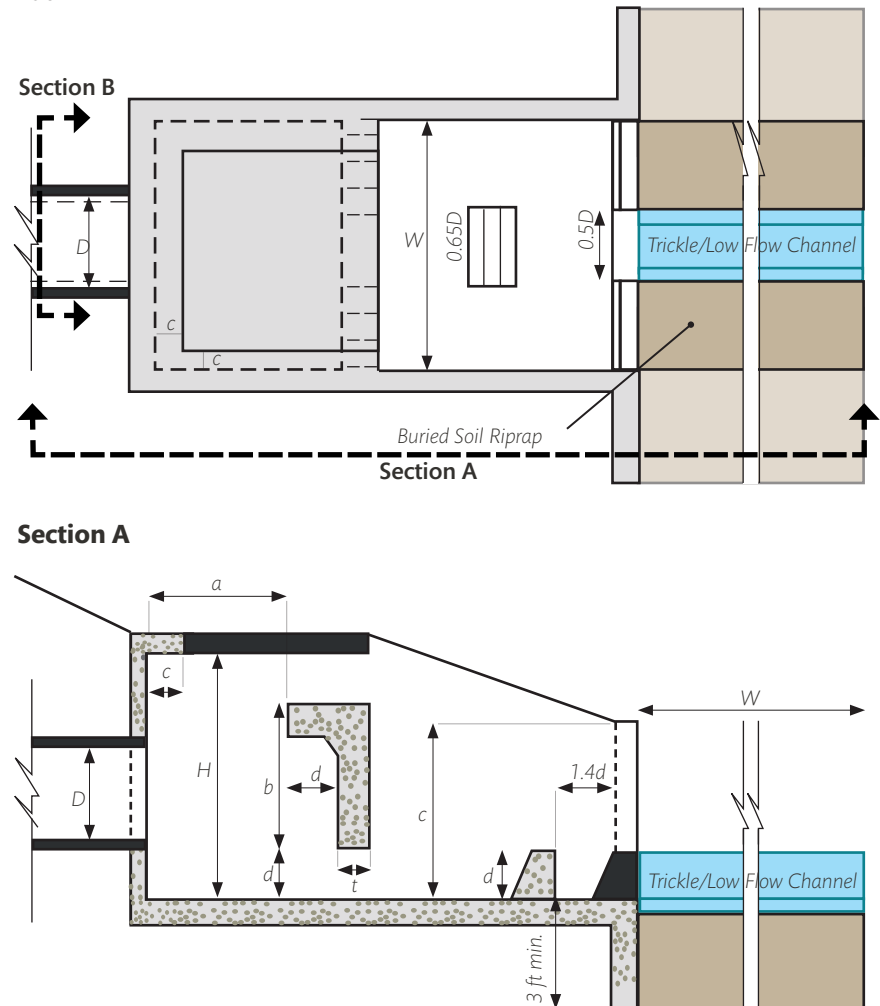
The type VI basin was originally designed to operate continuously at the design flow rate. However, it is applicable for use under the varied flow conditions of stormwater runoff. The use of this outlet basin is limited only by structural and economic considerations.

Energy dissipation is accomplished through the turbulence created by the loss of momentum as flow entering the basin impacts a large overhanging baffle. At high flow, further dissipation is produced as water builds up behind the

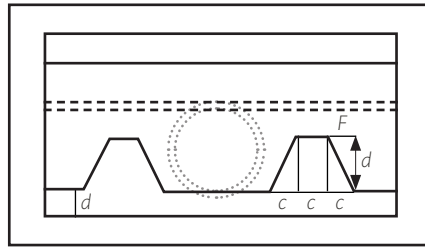
baffle to form a highly turbulent backwater zone. Flow is then redirected under the baffle to the open basin and out to the receiving channel. A check at the basin end reduces exit velocities by breaking up the flow across the basin floor and improves the stilling action at low to moderate flow rates.

The generalized, slightly modified, USBR Type IV Impact Basin design configuration is shown in [FIGURE 6.10.15](#) (Figure HS-14 in USDCM), which consist of an open concrete box attached directly to the conduit outlet.

**FIGURE 6.11.15 General Design Dimensions for USBR Type VI Impact Sill Basin**



**Section B**



**Equations:**

$$W = 2.94 [V/gD]^{0.556}$$

$$V = \text{Velocity, ft/s}$$

$$D = \sqrt{A}$$

$$A = \text{Area flow in sq. ft}$$

$$H = 3/4W$$

$$L = 4/3W$$

$$a = 1/2W$$

$$b = 3/8W$$

$$c = 1/2W$$

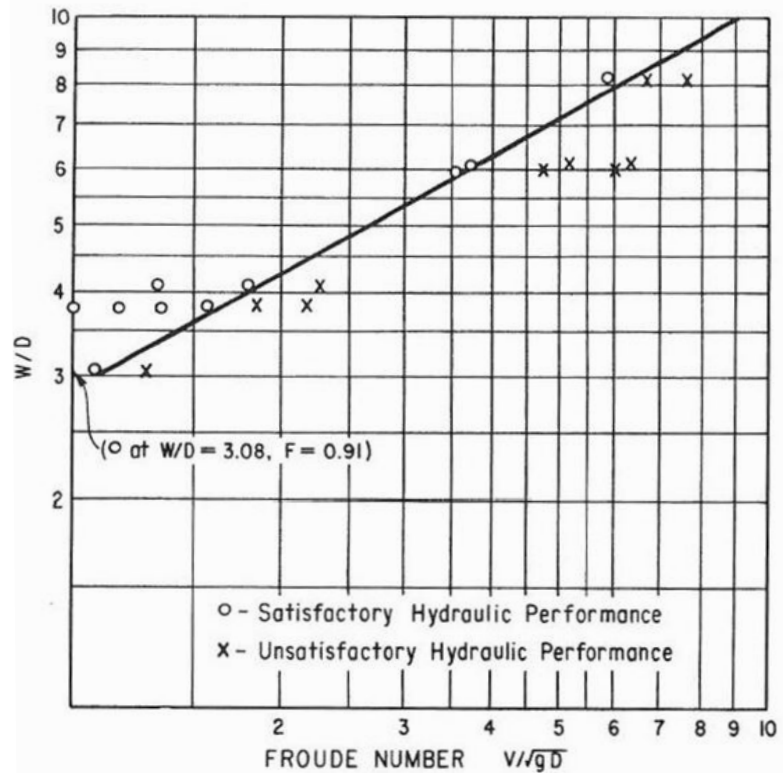
$$t = 1/12W$$

$$d = 1/6W$$

$$f = 1/8W$$

The width, W, is a function of the Froude number and can be determined using [FIGURE 6.10.16](#) (Figure HS-15 in USDCM). The sidewalls are high enough to contain most of the splashing during high flows and slope down to form a transition to the receiving channel. The inlet pipe is vertically aligned with an overhanging L-shaped baffle such that the pipe invert is not lower than the bottom of the baffle. The end check height is equal to the height under the baffle to produce tailwater in the basin. The alternate end transition (at 45 degrees) is recommended for grass-lined channels to reduce the downstream scour potential.

**FIGURE 6.11.16 Basin Width Diagram for USBR Type VI Impact Sill Basin**



"W" is the inside width of the basin.  
 "D" represents the depth of flow entering the basin and is the square root of the flow area at the conduit outlet.  
 "V" is the velocity of the incoming flow.  
 The tailwater depth is uncontrolled.

**NOTE:** Diagram provided by the Urban Drainage and Flood Control District, HS-15.

The impact basin can also be adapted to multiple pipe installations. Such modifications are discussed later in 6-10(G)(1)(i)(b), but it should be noted that modifications to the design may affect the hydraulic performance of the structure. Model testing of designs that vary significantly from the standard is recommended.

**6-11(G)(1)(i)(a) Modified Impact Basins for Smaller Outlets**

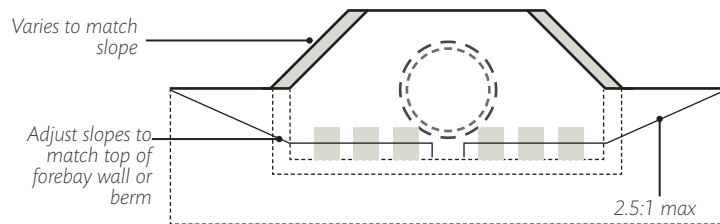
For smaller pipe outlets a modified version of the USBR Type IV Impact Basin is suggested in this Manual. **FIGURE 6.10.17** (Figure HS-16a in USDCM) provides a design layout for circular outlets ranging in size from 18-inches to 48-inches in diameter and **FIGURE 6.10.18** (Figure HS-16b in USDCM) for pipes 18-inches in diameter and smaller. The latter was added for primary use as an outlet energy dissipator upstream of forebays of small extended detention basins, sand filters and other structural best management practices requiring energy dissipation at the end of the pipe delivering water to the BMP facility.

**FIGURE 6.11.17 Modified Impact Sill Basin for Conduits 18" to 48" in Diameter**

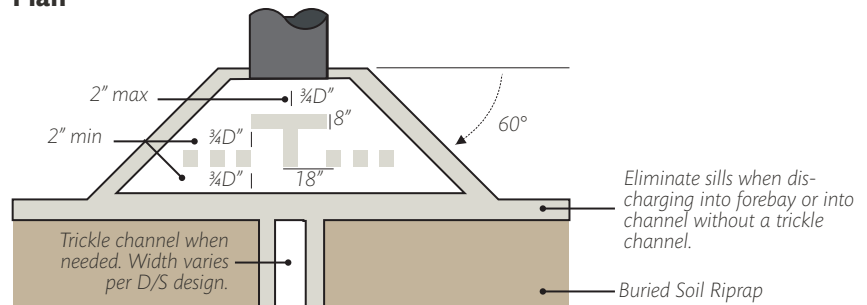
**NOTE:**

1. Design of reinforcing steel is the responsibility of the design engineer. Reinforce to withstand water earth pressures.
2. When discharging into channel and not forebay install Type M buried soil riprap for a distance of 3'D downstream of structure.

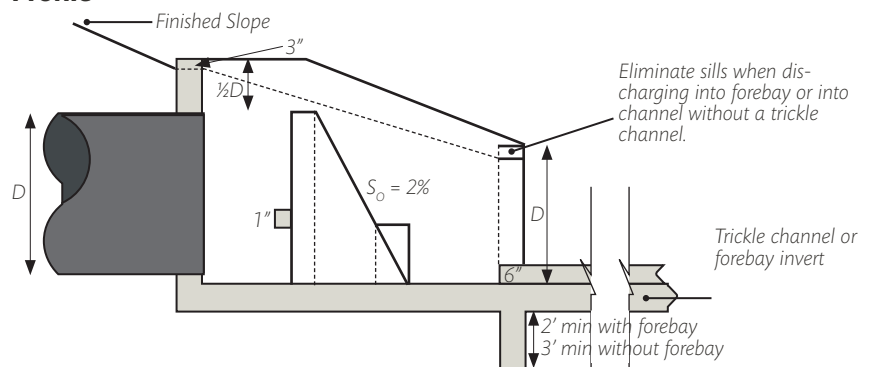
**Elevation**



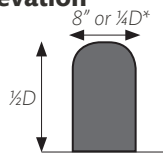
**Plan**



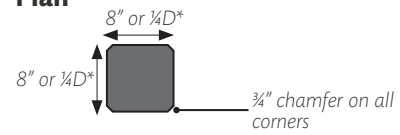
**Profile**



**Baffle Block Geometry**  
**Elevation**

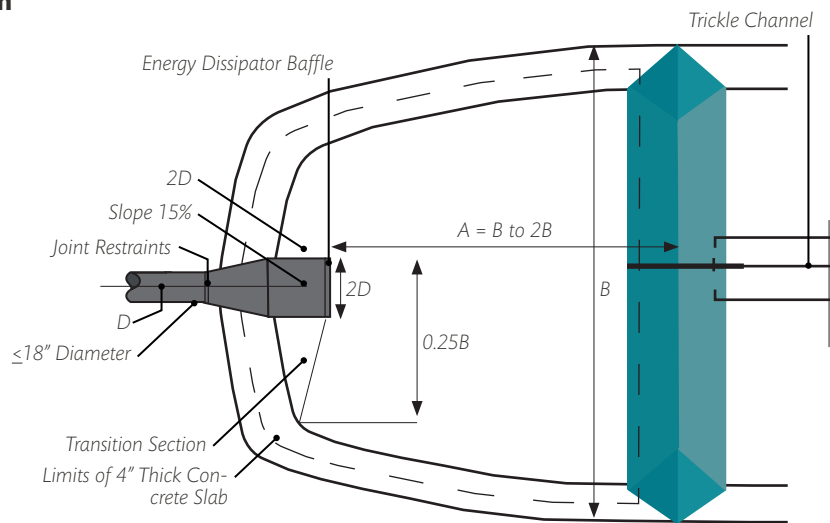


**Plan**

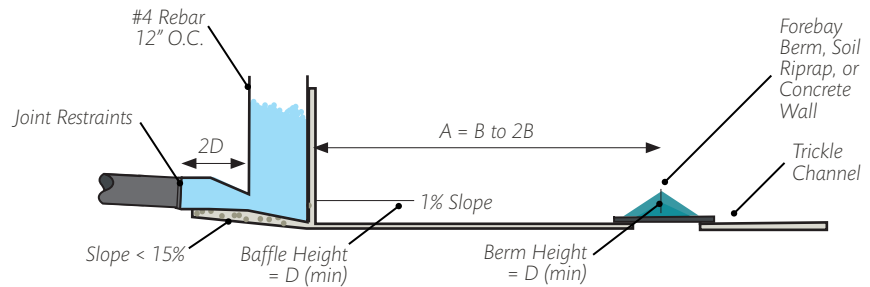


**FIGURE 6.11.18 Impact Stilling Basin for Pipes Smaller than 18" in Diameter Upstream of Forebays**

**Plan**



**Profile**



Unlike the Type IV Impact Basin, the modified basins do not require sizing for flow under normal stormwater discharge velocities recommended for storm sewers in this manual. However, their use is limited to exit velocities of 18 feet per second or less. For larger conduits and higher exit velocities, it is recommended that the standard Type IV Impact Basin be used instead.

**6-11(G)(1)(i)(b) Multiple Conduit Installations**

Where two or more conduits of different sizes outlet in proximity, a composite structure can be constructed to eliminate common walls. This can be somewhat awkward since each basin "cell" must be designed as an individual basin with different height, width, etc. Where possible, a more economical approach

is to combine storm sewers underground, at a manhole or vault, and bring a single combined pipe to the outlet structure.

When using a Type IV impact basin shown in [FIGURE 6.10.15](#) (Figure HS-14 in USDCM) for two side-by-side pipes of the same size, the two pipes may discharge into a single basin. If the basin's design width of each pipe is  $W$ , the combined basin width for two pipes would be  $1.5W$ . When the flow is different for the two conduits, the design width  $W$  is based on the pipe carrying the higher flow. For the modified impact basin shown in [FIGURE 6.10.17](#) (Figure HS-16a in USDCM), add  $1/2D$  space between the pipes and to each outside pipe edge when two pipes discharge into the basin to determine the width of the headwall and extent the width of the impact wall to match the outside edges of the two pipes. The effect of mixing and turbulence of the combined flows in the basin has not been model tested to date.

Remaining structure dimensions are based on the design width of a separate basin  $W$ . If the two pipes have different flow, the combined structure is based on the higher Froude number when designing the Type IV basins. Use of a handrail is suggested around the open basin areas where safety is a concern. Access control screens or grating where necessary are a separate design consideration. A hinged rack is also an alternative.

### **6-11(G)(1)(i)(c) General Design Procedure for Type IV Impact Basin**

1. Determine the design hydraulic cross-sectional area just inside the pipe, at the outlet. Determine the effective flow velocity,  $V$ , at the same location in the pipe. Assume  $D=(A_{sect})^{0.5}$  and compute the Froude number= $V/(gD)^{0.5}$ .
2. The entrance pipe should be turned horizontally at least one pipe diameter equivalent length upstream from the outlet. For pipe slopes greater than 15 degrees, the horizontal length should be a minimum of two pipe diameters.
3. Determine the basin width,  $W$ , by entering the Froude number and effective flow depth into [FIGURE 6.10.16](#) (Figure HS-15 in USDCM). The remaining dimensions are proportional to the basin width according to [FIGURE 6.10.15](#) (Figure HS-14 in USDCM). The basin width should not be oversized since the basin is inherently oversized for less than design flows. Larger basins become less effective as the inflow can pass under the baffle.
4. Structure wall thickness, steel reinforcement, and anchor walls (underneath the flow) should be designed using accepted structural engineering methods. Note that the baffle thickness,  $t_b$ , is a suggested minimum. It is not a hydraulic parameter and is not a substitute for structural analysis. Hydraulic forces on the overhanging baffle may be approximated by determination of the hydraulic jet force at the outlet:

**EQUATION 7.47**  $F_j = 1.94V_{out}Q_{des}$  (force in pounds)

**where:**

$Q_{des}$  = maximum design discharge (cfs)

$V_{out}$  = velocity of the outlet jet (ft/sec)

5. Type "M" rock riprap should be provided in the receiving channel from the end check to a minimum distance equal to the basin width. The depth of

- rock should be equal to the check height or at least 2.0 feet. Rock may be buried to finished grades and planted as desired.
6. The alternate end check and wingwall shown in [FIGURE 6.10.15](#) (Figure HS-14 in USDCM) are recommended for all grass-lined/earthen channel applications to reduce the scour potential below the check wall.
  7. Ideally, the low-flow invert matches the floor invert at the basin end and the main channel elevation is equal to the top of the check. For large basins where the check height,  $d$ , becomes greater than the low-flow depth, dimension  $d$  in [FIGURE 6.10.15](#) (Figure HS-14 in USDCM) may be reduced by no more than one-third. It should not be reduced to less than 2 feet. This implies that a deeper low-flow channel (1.5 to 2.0 feet) will be advantageous for these installations. The alternate when the check height,  $d$ , exceeds the trickle floor depth is that the basin area will not drain completely.
  8. A check section should be constructed directly in front of the low-flow notch to break up bottom flow velocities. The length of this check section should overlap the width of the low flow and its dimension is shown in [FIGURE 6.10.15](#) (Figure HS-14 in USDCM).

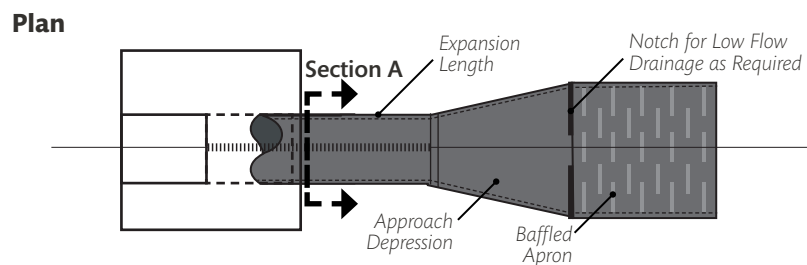
### 6-11(G)(1)(ii) [Pipe Outlet Rundowns](#)

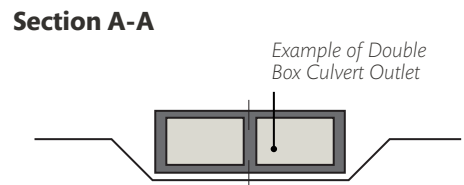
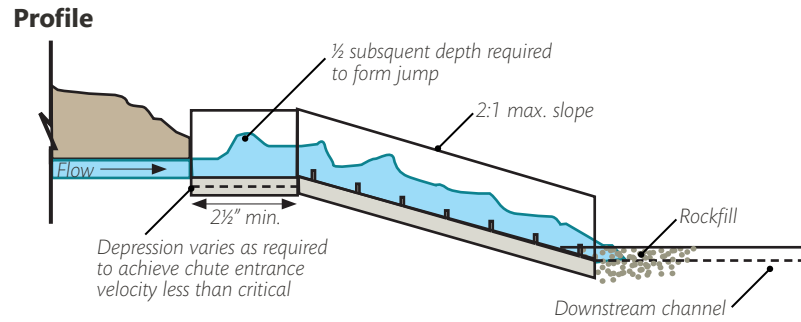
#### 6-11(G)(1)(ii)(a) [Baffle Chute Rundown](#)

The baffle chute developed by the USBR (1958) has also been adapted to use at pipe outlets. This structure is well suited to situations with large conduit outfalls and at outfalls to channels in which some future degradation is anticipated. As mentioned previously, the apron can be extended at a later time to account for channel degradation. This type of structure is only cost effective if a grade drop is necessary below the outfall elevation.

[FIGURE 6.10.19](#) (Figure HS-17 in USDCM) illustrates a general configuration for a baffled outlet application for a double box culvert outlet. In this case, an expansion zone occurs just upstream of the approach depression. The depression depth is designed as required to reduce the flow velocity at the chute entrance. The remaining hydraulic design is the same as for a standard baffle chute using conditions at the crest to establish the design. The same crest modifications are applicable to allow drainage of the approach depression, to reduce the upstream backwater effects of the baffles, and to reduce the problems of debris accumulation and standing water at the upstream row of baffles.

**FIGURE 6.11.19 Baffle Chute Pipe Outlet**





**NOTE:** Section A Possible expansion as required for pipe hydraulics and for unit discharge.

Flow entering the chute should be well distributed laterally across the width of the chute. The velocity should be below critical velocity at the crest of the chute. To insure low velocities at the upstream end, it may be necessary to provide a short energy dissipating pool. The sequent or conjugate depth in the approach basin should be sized to prevent jump sweep-out, but the basin length may be considerably less than a conventional hydraulic jump basin since its primary purpose is only to reduce the average entrance velocity. A basin length of twice the sequent depth will usually provide ample basin length. The end check of the pool may be used as the crest of the chute as shown in [FIGURE 6.10.19](#) (Figure HS-17 in USDCM).

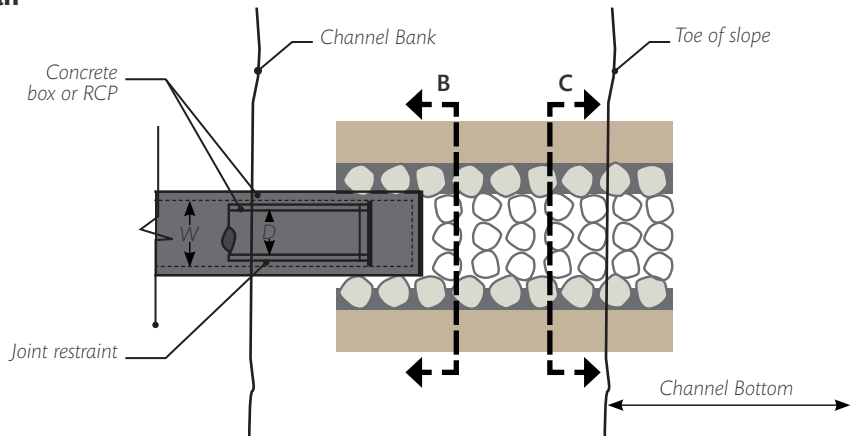
### 6-11(G)(1)(ii)(b) Grouted Boulder Chute Rundown

Another option for rundowns at outlets of larger pipes is to use a grouted boulder rundown illustrated in [FIGURE 6.10.20](#) (Figure HS-18 in USDCM). This type of rundown has been used successfully for several large storm sewers entering the South Platte River. It is critical that the details shown in [FIGURE 6.10.20](#) (Figure HS-18 in USDCM) be strictly followed and the grout and the actual filling of spaces between the boulders with grout closely adhere to the recommendations for grouted boulders.

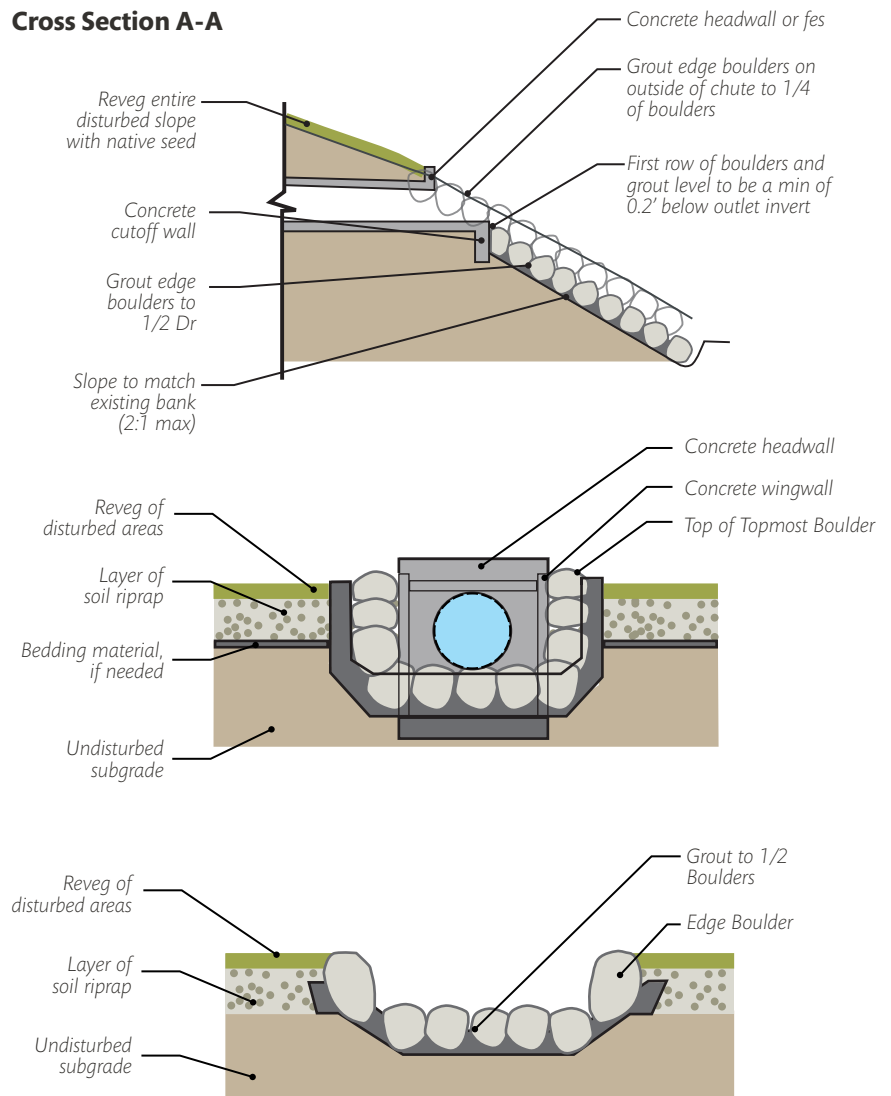
If the exit velocities of the pipe exceeds 12 feet per second, an approach chute for the baffle chute rundown described above should be considered and provided.



**FIGURE 6.11.20 Grouted Boulder Rundown Plan**



**Cross Section A-A**



### 6-11(G)(1)(ii)(c) Low Tailwater Riprap Basins at Pipe Outlets

The design of low tailwater riprap basins for storm sewer pipe outlets and at some culvert outlets is necessary when the receiving or downstream channel may have little or no flow or tailwater at time when the pipe or culvert is in operation. Design criteria are provided in [FIGURE 6.10.23](#) (Figure HS-19a in USDCM) through [FIGURE 6.10.26](#) (Figure HS-20c in USDCM).

By providing a low tailwater basin at the end of a storm sewer conduit or culvert, the kinetic energy of the discharge is dissipated under controlled conditions without causing scour at the channel bottom. [FIGURE 6.10.21](#) (Photograph HS-12 in USDCM) shows a fairly large low tailwater basin.

**FIGURE 6.11.21 Upstream and Downstream Views of a Low Tailwater Basin in Douglas County**

**NOTE:** Photographs provided by the Urban Drainage and Flood Control District.



Low tailwater basin design is described below. Low tailwater is defined as being equal to or less than 1/3 of the height of the storm sewer, that is:

$$\text{EQUATION 7.48 } Y_t \leq D/3 \text{ or } Y_t \leq H/3$$

**where:**

$Y_t$  = tailwater depth at design

$D$  = diameter of circular pipe (ft)

$H$  = height of rectangular pipe (ft)

1. Finding Flow Depth and Velocity of Storm Sewer Outlet Pipe
  - a. The first step in the design of a scour protection basin at the outlet of a storm sewer is to find the depth and velocity of flow at the outlet. Pipe-full flow can be found using Manning's equation. See [Part 6-13\(D\)](#).
  - b. Then the pipe-full velocity can be found using the continuity equation.

$$\text{EQUATION 7.49 } V_{full} = Q_{full} / A_{full}$$

- c. The normal depth of flow,  $d$ , and the velocity in a conduit can be found with the aid of [FIGURE 6.10.24](#) (Figure HS-20a in USDCM) and [FIGURE 6.10.25](#) (Figure HS-20b in USDCM). Using the known design discharge,  $Q$ , and the calculated pipe-full discharge,  $Q_{full}$ , enter [FIGURE 6.10.24](#) (Figure HS-20a in USDCM) with the value of  $Q/Q_{full}$  and find  $d/D$  for a circular pipe or  $d/H$  for a rectangular pipe.
- d. Compare the value of  $d/D$  (or  $d/H$ ) with the one obtained from [FIGURE 6.10.25](#) (Figure HS-20b in USDCM) using the Froude parameter,  $Q/D^{2.5}$  or  $Q/(wH^{1.5})$ .
- e. Choose the smaller of the two ( $d/D$  or  $d/H$ ) ratios to calculate the flow depth at the end of pipe.

EQUATION 7.50  $D=D(d/D)$  or  $d=H(d/H)$

- f. Again, enter [FIGURE 6.10.23](#) (Figure HS-19a in USDCM) using the smaller  $d/D$  (or  $d/H$ ) ratio to find the  $A/A_{full}$  ratio. Then,

EQUATION 7.51  $A=(A/A_{full})A_{full}$

- g. Finally,<sup>5</sup>

EQUATION 7.52  $V=Q/A$

**where:**

$A_{full}$  = cross sectional area of the pipe (ft<sup>2</sup>)

$A$  = area of the design flow in the end of the pipe (ft<sup>2</sup>)

2. Riprap Size

- a. For the design velocity, use [FIGURE 6.10.26](#) (Figure HS-20c in USDCM) to find the size and type of the riprap to use in the scour protection basin downstream of the pipe outlet (e.g. B18, H, M, or L). First calculate the riprap sizing design parameter,  $P_d$ , namely,

EQUATION 7.53  $P_d=(V^2+gd)^{0.5}$

**where:**

$V$  = design flow velocity at pipe outlet (ft/sec)

$g$  - acceleration due to gravity = 32.2 ft/sec<sup>2</sup>

$d$  = design depth of flow at pipe outlet (ft)

- i. When the riprap sizing design parameter indicates conditions that place the design above the Type H riprap line in [FIGURE 6.10.24](#) (Figure HS-20 in USDCM), use B18, or larger, grouted boulders. An alternate to a grouted boulder or loose riprap basin is to use the standard USBR Impact Basin VI or one of its modified versions, described earlier in this Section.

- b. After the riprap size has been selected, the minimum thickness of the riprap layer,  $T$ , in feet, in the basin is set at:

EQUATION 7.54  $T = 1.75D_{50}$

**where:**

$D_{50}$  = the median size of the riprap

Riprap Type	D50- Median Rock Size (inches)
L	9
M	12
H	18
B18	18 (minimum dimension of grouted boulders)

3. Basin Length

- a. The minimum length of the basin,  $L$ , in [FIGURE 6.10.22](#) (Figure HS-20 in USDCM), is defined as being the greater of the following:

<sup>5</sup> See Section 22.16 for definitions of the Manning's equation.

EQUATION 7.55 **For circular pipe:**  $L = 4D$  or  $L = (D)^{0.5}(V/2)$

EQUATION 7.56 **For rectangular pipe:**  $L = 4H$  or  $L = (H)^{0.5}(V/2)$

**where:**

**L** = basin length

**H** = height of rectangular conduit

**V** = design flow velocity at outlet

**D** = diameter of circular conduit

4. Basin Width

- a. The minimum width, *W*, of the basin downstream of the pipes flared end section is set as follows:

EQUATION 7.57 **For circular pipe:**  $W = 4D$

EQUATION 7.58 **For rectangular pipe:**  $W = w+4H$

**where:**

**W** = basin width

**D** = diameter of circular conduit

**w** = width of rectangular conduit

5. Other Design Requirements

- a. All slopes in the pre-shaped riprapped basin are 2H to 1V.  
 b. Provide pipe joint fasteners and a structural concrete cutoff wall at the end of the flared end section for a circular pipe or a headwall with wingwalls and a paved bottom between the walls, both with a cutoff wall that extends down to a depth of:

EQUATION 7.59  $B = D/2 + T$  or  $B = H/2 + T$

**when:**

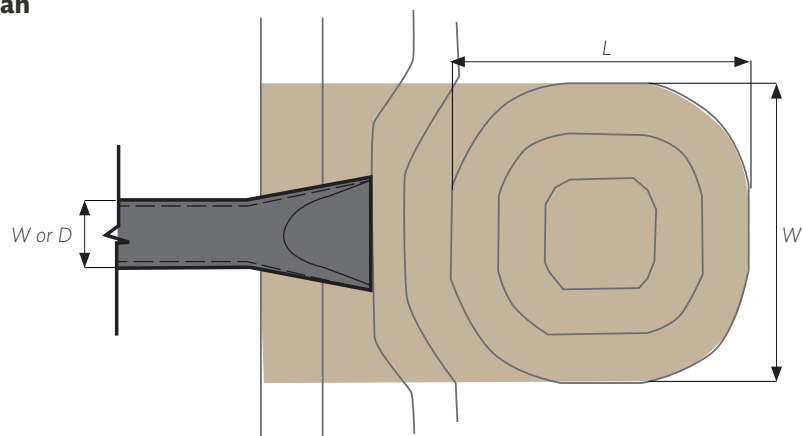
**B** = cutoff wall depth

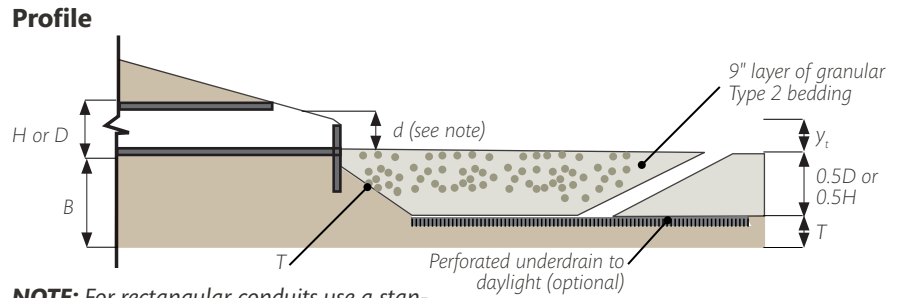
**D** = diameter of circular conduit

**T** =  $1.75D_{50}$

The riprap must be extended up the outlet embankment's slope to the mid-pipe level.

**FIGURE 6.11.22 Low Trailwater Riprap Basins for Storm Sewer Piper Outlets (HS-19) Plan**





**NOTE:** For rectangular conduits use a standard design for a headwall with wingwalls, paved bottom between the wingwalls, with an end cutoff wall extending to a minimum depth equal to  $B$ .

**FIGURE 6.11.23 Concrete Flared End Section with Cutoff Wall for all Pipe Outlets**

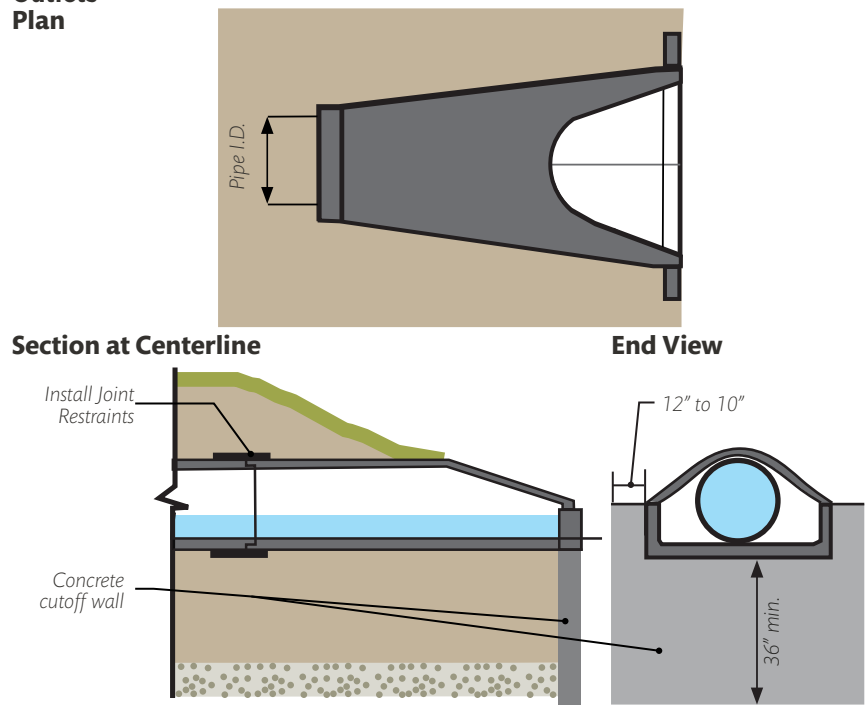


FIGURE 6.11.24 Low Trailwater Riprap Basins for Storm Sewer Pipe Outlets - Discharge and Flow Area Relationships for Circular and Rectangular Pipes

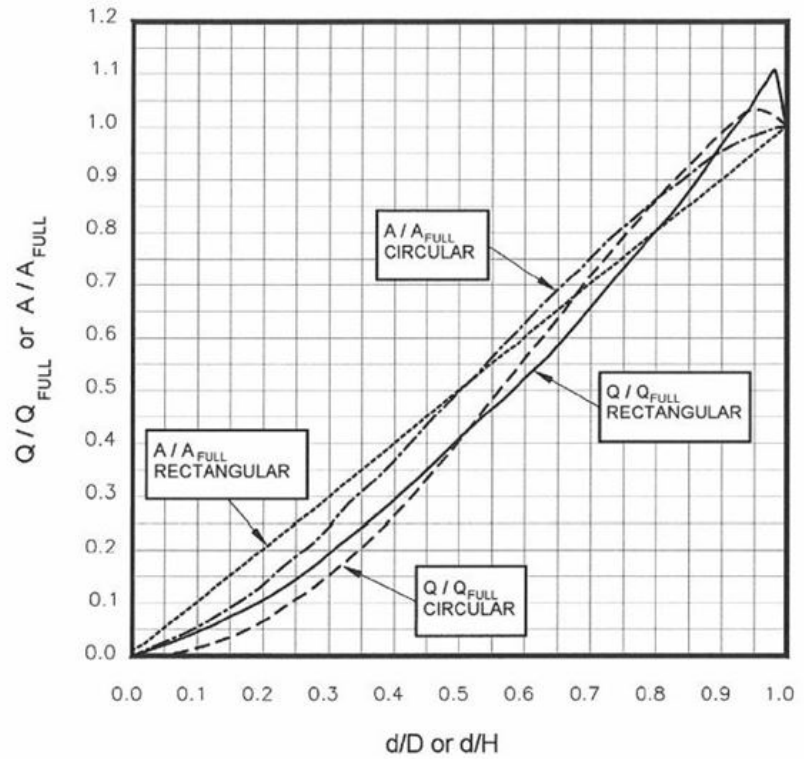


FIGURE 6.11.25 Low Trailwater Riprap Basins for Storm Sewer Pipe Outlets - Brink Depth Horizontal Pipe Outlet

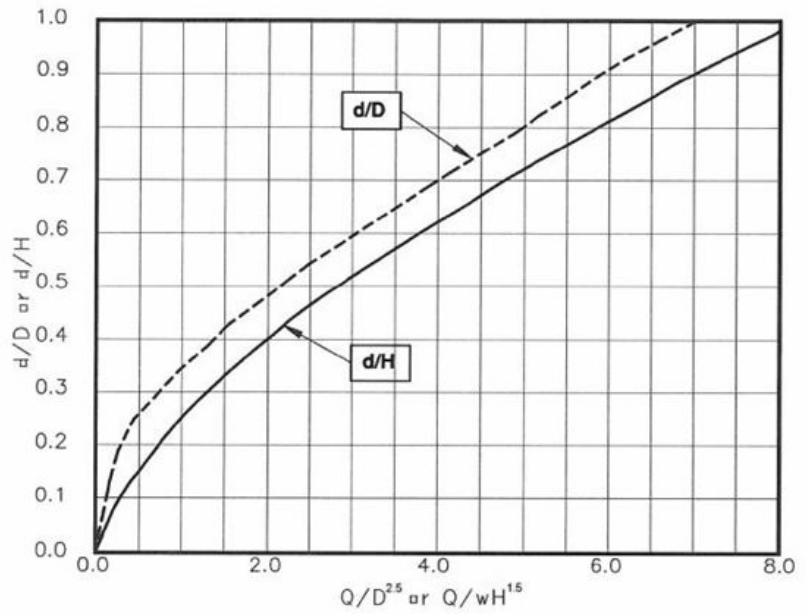
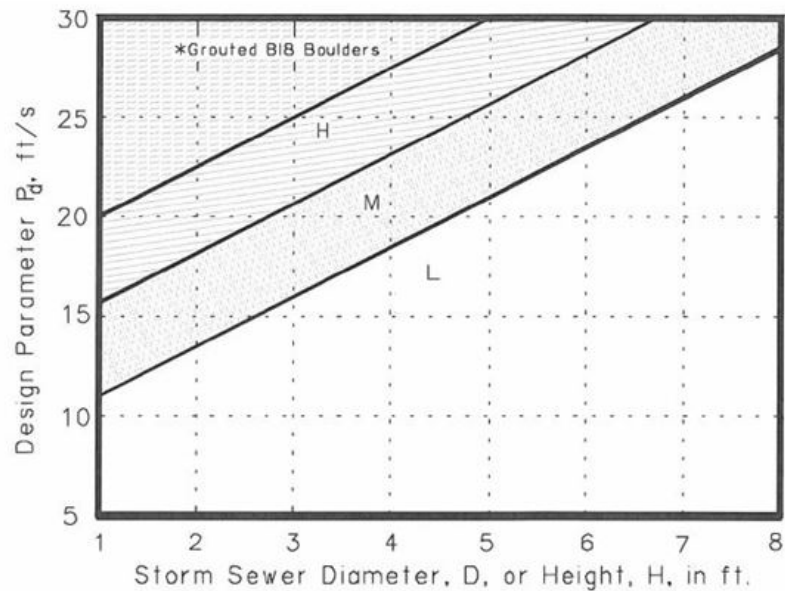


FIGURE 6.11.26 Low Trailwater Riprap Basins for Storm Sewer Pipe Outlets - Riprap Selection Chart for Low Tailwater Basin at Pipe Outlet



### 6-11(G)(1)(iii) [Culvert Outlets](#)

Culvert outlets represent a persistent problem because of concentrated discharges and turbulence that are not fully controlled prior to the flow reaching the standard downstream channel configuration. Too often the designer's efforts are focused on the culvert inlet and its sizing with outlet hydraulics receiving only passing attention. Culvert design is not complete until adequate attention is paid to the outlet hydraulics and proper stilling of the discharge flows.

Culvert outlet energy dissipater and flow spreading may require special structures downstream of the culvert outlet to limit local scour, general stream degradation, and troublesome head cutting. Some of the techniques described earlier in this section may be applied at culvert outlets, as well if the downstream channel and/or tailwater conditions so indicate.

Local scour is typified by a scour hole at the pipe's outlet. High exit velocities cause this, and the effects extend only a limited distance downstream. Coarse material scoured from the hole is deposited immediately downstream, often forming a low bar. Finer material is transported further downstream. The dimensions of the scour hole change due to sedimentation during low flows and the varying erosive effects of storm events. The scour hole is generally deepest during passage of the flow when there is minimal tailwater depth at the outlet and not necessarily when the flow is highest. Methods for predicting scour hole dimensions are found in [HEC No. 14](#) (Corry, et al. 1975) and need to be applied using a range of possible tailwater depth conditions during different design storms or flows.

General storm degradation, or head cutting, is a phenomenon independent of culvert performance. Natural causes produce a lowering of the streambed over



time. The identification of a degrading stream is an essential part of the original site investigation. However, high-energy discharges from a culvert can often cause stream degradation for a limited distance downstream. Both scour and stream degradation can occur simultaneously at a culvert outlet.

Various measures described in HEC No. 14 and listed below need to be considered to protect the downstream channel or stream and control culvert outlet flow. It is beyond the scope of the manual to provide detailed information about all available controls in HEC No. 14, but the City encourages the proper application and design as appropriate for the specific site.

**FIGURE 6.11.27 Unprotected Culvert Outlets Cause Downstream Erosion**



**NOTE:** Photographs provided by the Urban Drainage and Flood Control District.

### **PUBLIC FACILITIES ADDITIONAL EROSION PROTECTION CRITERIA**

The facility is considered Public if it maintained publicly or has a Public Drainage Easement upon it.

1. A filter fabric or gravel is to be used in all cases under the riprap.
2. The velocity leaving the energy dissipator/ erosion protection shall be 5 ft/sec or less unless justified.

### **Section. 6-11(G)(2) Private Storm Drain Outlets to Onsite Basins or Swales**

1. The following criteria is acceptable for privately maintained facilities where the storm drain is less than 18 inches in diameter. For private storm drains 18 inches and greater, refer to the sections for public facilities.
2. Criteria:
  - a. Provide erosion control for velocities 5 ft/sec or greater.
  - b. The pipe invert should be at or close to the invert of the receiving basin or swale.

## **Part. 6-11(H) Protection and Debris Barriers**

### **Section. 6-11(H)(1) Protection Barriers**

A protection barrier is a means of preventing people from entering storm drains. Protection barriers will be provided wherever necessary to prevent



unauthorized access to storm drains. In some cases the barrier may be one of the breakaway type. In other cases the barrier may be a special design. It will be the designer's responsibility to provide a protection barrier appropriate to each situation and to provide details of such on the construction drawings.

### **Section. 6-11(H)(2) Debris Barriers**

A debris barrier or deflector is a means of preventing large debris or trash, such as tree limbs, logs, boulders, weeds, and refuse, from entering a storm drain and possibly plugging the conduit. The debris barrier should have openings wide enough to allow as much small debris as possible to pass through and yet narrow enough to protect the smallest conduit in the system downstream of the barrier.

One type that has been used effectively in the past is the debris rack. This type of debris barrier is usually formed by a line of posts, such as steel pipe filled with concrete or steel rails, across the line of flow to the inlet. It will be the designer's responsibility to provide a debris barrier or deflector appropriate to the situation and acceptable to the City Engineer.

### **Section. 6-11(H)(3) Debris Basins**

Debris basins, check dams and similar structures are a means of preventing mud, boulders and debris held in suspension and carried along by storm runoff from depositing in storm drains. Debris basins constructed upstream of storm drain conduits, usually in arroyos, trap such material before it reaches the conduit. Debris basins must be cleaned out on a regular basis, however, if they are to continue to function effectively. Refer to the City Engineer and State Engineer regarding the criteria to be used in designing these structures.

## **Part. 6-11(I) Closed Conduit Angle of Confluence**

Connector pipe may be joined to main line pipe at angles greater than 45 degrees up to a maximum of 90 degrees provided none of the above conditions exist. Under high velocity and high flow conditions it is preferable for the angle of confluence to be 45 degrees or less.

In general, the angle of confluence between main line and lateral must not exceed 45 degrees and, as an additional requirement, must not exceed 30 degrees under any of the following conditions:

1. Where the peak flow (Q) in the proposed lateral exceeds 10 percent of the main line peak flow.
2. Where the velocity of the peak flow in the proposed lateral is 20 f.p.s. or greater.
3. Where the size of the proposed lateral is 60 inches or greater.
4. Where hydraulic calculations indicate excessive head losses may occur in the main line due to the confluence.

If, in any specific situation, one or more of the above conditions does apply, the angle of confluence for connector pipes may not exceed 30 degrees. Connections must not be made to main line pipe which may create conditions

of adverse flow in the connector pipes without prior approval from the City Engineer.

The above requirements may be waived only if calculations are submitted to the City Engineer showing that the use of a confluence angle larger than 30 degrees will not unduly increase head losses in the main line.

### **Part. 6-11(J) Flapgates**

A flapgate must be installed in all laterals outletting into a main line storm drain whenever the potential water surface level of the main line is higher than the surrounding area drained by the lateral.

The flapgate must be set back from the main line drain so that it will open freely and not interfere with the main line flow. A junction structure will be constructed for this purpose in accordance with City Engineer standards.

### **Part. 6-11(K) Rubber-Gasketed Pipe**

Rubber-gasketed pipe will be used in all storm drain construction unless otherwise approved by the City Engineer.

### **Part. 6-11(L) Junctions into Existing Storm Drain Main Lines**

Junctions will only be permitted on mains storm drain lines that are >42 inches. Junction locations cannot be more than 24' from the downstream manhole. The maximum lateral size is 24". The City Engineer's approval will be required for variances.

### **Part. 6-11(M) Submittal Requirements**

#### **Section. 6-11(M)(1) Hydraulic Model**

1. If a Letter of Map Change is to be submitted to FEMA, the model is to be on the approved FEMA models list at the time of submittal. Approved models are shown on FEMA's website.
2. Electronic hydraulic models must meet the following criteria to be accepted:
  - a. *Be able to produce an illustration of the HGL and EGL.*
  - b. *Have the ability to include major and minor losses.*
  - c. *Meet technical requirements of this chapter.*
  - d. *The engineer shall include a description of how the model meets the requirements of this chapter and should describe how losses were taken into account.*
3. For the purposes of generating an infrastructure list, in lieu of submitting the results of an electronic model, the engineer may submit pipe capacity calculations based on gravity flow using Manning's equation.

4. An electronic model is required to design the storm drain for the construction plans.

### **Section. 6-11(M)(2) Culverts**

1. The City has adopted the [Federal Highway Administration, Hydraulic Design Series Number 5](#), method for culvert design.
2. If a proprietary model is used to design a culvert, the engineer shall include a description of how the model is in compliance with the [FHWA](#) method.

## **ARTICLE 6-12 POND REQUIREMENTS**

### **Part. 6-12(A) Design Requirements**

Some sites may require ponding due to limited downstream capacity. The downstream capacity will be identified in a previously approved drainage plan/report or identified in the drainage submittal. Ponds are of the following types:

#### **Section. 6-12(A)(1) Detention Ponds**

A detention pond has an outfall pipe with an outflow rate less than the inflow rate. All detention ponds must be evacuated in twenty four (24) hours or less, except for the stormwater quality volume. See [Article 6-12](#) for stormwater quality volume. The discharge from some ponds may be more limited by downstream constraints and take longer to evacuate. In these cases, approval of an evacuation time greater than 24 hours is required by the City Engineer. Ponds that take more than six (6) hours to drain will be designed for a design storm equal to or exceeding the evacuation time.

Within a detention pond you can have a water quality pond. The water quality volume is excluded from the evacuation criteria as this volume is to infiltrate.

There are numerous software packages that can be used to calculate the pond volume. The input and output parameters and definitions are to be included with the drainage submittal.

The pond volume can also be calculated manually by discretizing the inflow hydrograph then subtracting the outflow hydrograph.

The minimum outfall size shall be 4 inches in diameter, width or depth. An outlet less than 4 inches in diameter, width or depth may be utilized if accompanied by a maintenance schedule on the City approved drainage submittal. Detention ponds shall have a designated overflow point that indicates the flow direction if the pond overtops.

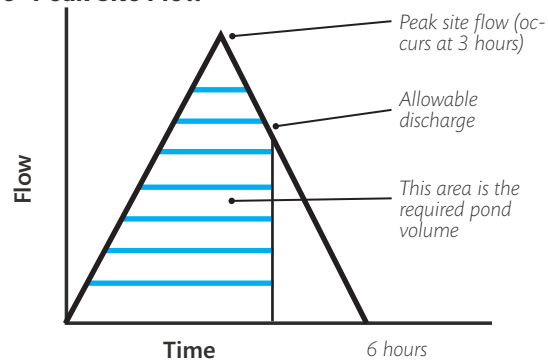
#### **Section. 6-12(A)(2) Retention Ponds**

A retention pond retains stormwater to be infiltrated for the specified design storm. Depending on soil characteristics, the soil on the pond bottom may

have to be amended or an infiltration system designed to evacuate the pond within 96 hours.

1. For sites that do not have an outfall, the pond volume will be based on a 100 year 10-day storm.
2. The retention ponds listed below are for sites that have limited downstream capacity, and should have a detention pond, but a detention pond cannot be designed since the outfall pipe could not daylight. Volumes listed below are in addition to the stormwater quality volume.
  - a. For sites that drain to adjoining private property historically, wherein the adjoining private property does not have an outfall; the pond shall be sized for the 100yr-24hr storm. The adjoining property should not see a change in peak flow or total volume.
  - b. For sites that drain to adjoining private property historically, wherein the adjoining private property has an outfall, the pond shall be sized for half the runoff from the 100yr-24 hour storm. The adjoining property should not see a change in the peak flow.
  - c. For sites that drain to a public facility, but have limited capacity, the pond shall be sized via the graphical method shown below.
3. Retention ponds shall have a designated overflow point that indicates the flow direction if the pond overtops.

FIGURE 6.12.28 Peak Site Flow



### Section. 6-12(A)(3) Surge Ponds

A surge pond functions by ponding the flow in excess of the storm drain capacity. Therefore, lower flows by-pass the pond in the storm drain. Since stormwater quality cannot be addressed in a surge pond, its use is limited to a multi-use facility (e.g. park). Stormwater quality is to be addressed upstream or downstream of the pond prior to discharge to the Rio Grande River.

### Section. 6-12(A)(4) Stormwater Quality Ponds

Water quality ponds are addressed in [Article 6-12](#).

## Part. 6-12(B) Infiltration Rate

If infiltration rate credit is to be used, it must be supported by a Double-ring Infiltrometer test per ASTM D3385 at the proposed pond bottom. The test results are to be certified by a licensed engineer. In lieu of the double-ring Infiltrometer test, the infiltration rate shall not exceed the rates specified in [TABLE 6.2.7](#) per the soil type as described in [TABLE 6.2.3](#) of [Part. 6-2\(A\)](#).

### **Part. 6-12(C) Ponds in Parking Areas**

Unless otherwise approved by the City Engineer, all ponds in parking lots that affect parking areas must be detention ponds and the depth is not to exceed 8" in any portion of the parking space or parking stall.

### **Part. 6-12(D) Fencing Around Ponds**

Fencing or similar barricade that will prevent entry is required for private and public ponds where the water depth is 18 inches or greater unless side slopes are 3:1 (H:V) or flatter and the pond drains in 96 hours or less. Fence or barricade minimum height is to be 42 inches.

### **Part. 6-12(E) Private Ponds to be Built to Public Pond Specifications**

Private ponds (no Public water or Public Drainage Easement) are to be maintained by the property owner or the party specified on the plat or easement document. If the City finds the pond is not being maintained to the specifications in the drainage report/plan, the City may take over maintenance responsibility of the pond.

Since at a later date, maintenance of the pond may be taken over by the City, Private ponds 2.0 ac-ft and larger are required to be built per Public Pond specifications set forth later in this chapter.

The owner or party specified on the plat or easement document may be financially responsible to the City per [§14-5-2-14](#) of the Drainage Control Ordinance.

### **Part. 6-12(F) Rock Void Space for Pond Volume**

For underground storage systems the pore void spaces between the aggregate is available to store water. The allowed volume in the aggregate pore void space is 30%. The aggregate is to be natural or uncrushed and be protected from silt and sediment.

There is no pore space volume allowed for surface installations.

### **Part. 6-12(G) Privately Maintained Ponds with a Public Drainage Easement**

Privately maintained ponds which will detain or retain public water must have a Public Drainage Easement and an Agreement and Covenant and be built to City of Albuquerque standards presented later in this section. Ponds exclusively constructed to meet the requirements of [Article 6-12](#) are excluded.

## **Part. 6-12(H) City Maintained Ponds**

### **Section. 6-12(H)(1) Access**

Access shall be required for all city maintained ponds. Access shall be opposite the outlet if possible with a minimum width of 12 feet. Maximum access slope shall be 10:1 (6:1 if hard surfaced with soil cement or concrete treated base). Standard design tube or pipe gates shall be installed to restrict vehicle access. Gates shall be set back 50 feet from arterial or collector streets so equipment does not have to park in the street.

### **Section. 6-12(H)(2) Spillways**

Emergency spillways shall always be provided, be erosion resistant, and discharge to a public right-of-way, public drainage easement and/or historic flow path. An emergency spillway must safely convey the 100 year design flow entering the pond.

### **Section. 6-12(H)(3) Outlets**

1. Outlet structures shall be gravity flow, whenever feasible, and be located in a corner or accessible edge of the pond. Outlets shall be opposite of the pond access point if possible. Outlet pipe shall be a minimum of 12 inches in diameter with a slope such that when flowing at 1/4 full, velocity is 3 fps or greater.
2. The outlet should be surrounded by a stabilized grade pad appropriately sized for maintenance.
3. The invert of the pond outlet shall be above the required water quality volume as demonstrated in the drainage report. The pond outlet shall also provide a means to remove floatables and debris.

### **Section. 6-12(H)(4) Pond Bottoms**

1. Pond bottoms shall be designed to convey flows from the inlet to a storm water pollution prevention feature (such as a pervious bottom area for infiltration) prior to discharging to the outlet.
2. Ease of maintenance shall be a consideration in all dams/detention basins.

### **Section. 6-12(H)(5) Side Slope and Bottom Treatments**

1. Vegetation will be accepted if seeded per the [\*City of Albuquerque Standard Specifications for Public Works Construction\*](#).
2. Aggregate or riprap may be used as an erosion control mulch for 3:1 and steeper slopes.
3. A geotechnical investigation and report may be required at the discretion of the City Engineer.

### **Section. 6-12(H)(6) Minimum Pond Size**

In order for a pond to be publicly maintained, it must be a minimum of two (2) acre-feet.

### **Section. 6-12(H)(7) Fencing**

1. Ponds 18 inches or greater in depth will require fencing unless side slopes are 3:1 or flatter and the pond drains in 96 hours or less.
2. If fencing is required, the minimum height is 42 inches. All fencing shall conform with the City of Albuquerque Standard Specifications for Public Works Construction.

### **Part. 6-12(I) Temporary Public Ponds**

1. Interim or temporary facilities shall be protected by a Public Drainage Easement and have an Agreement and Covenant for maintenance. These public drainage easements may cover a tract of land larger than that needed for the final permanent facility in lieu of financial guarantees. An agreement and covenant by the developer will be required due to the temporary nature of the facility.
2. Retention pond volume will be based on a 100 year 10-day storm with no percolation credit given for volume reduction.
3. An emergency spillway must be provided that will safely convey the 100 year design flow entering the pond.

### **Part. 6-12(J) Pond Evacuation Time**

All ponds are to be evacuated within 96 hours to comply with State Engineer water rights and to minimize the habitat for mosquitoes.

If soil conditions or bedrock extend the evacuation time to greater than 96 hours, the property owner is to consult with the City Engineer and provide the results of this consultation to the City.

### **Part. 6-12(K) Infiltration System Design**

An infiltration system design should have the width or length dimensions, in plan view, greater than the depth dimension otherwise it is considered an injection well and a permit from the New Mexico Environment Department is required.

The infiltration system design should include a filter material to prevent fine material from entering the system.

## ARTICLE 6-13 STORMWATER QUALITY AND LOW IMPACT DEVELOPMENT

New development and redevelopment sites are required to capture and infiltrate the stormwater quality volume. The stormwater quality volume is the stormwater runoff from small storms and the initial portion of runoff from larger storms. Stormwater quality requirements shall be satisfied either onsite, offsite or by making a payment-in-lieu, (See [Part. 6-12\(D\)](#)). Onsite means on the lot where improvements are to be constructed or if a common plan of development, as demonstrated in the drainage report, a location designed for stormwater management or as otherwise approved by the City Engineer.

New Development is defined as “The process of adding improvements to a parcel of land, such as grading, subdivisions, drainage, access, roadway/street improvements, impervious driving surfacing and utilities. This applies to parcels of lands with little to no previous human-caused disturbances, or otherwise in a natural state.”

Redevelopment is defined as “Improvements made to a parcel of land that was previously developed (see “New Development”).”

The stormwater quality volume for new development sites are required to manage is the runoff from a 0.62 inch storm, which corresponds to the 90th percentile of all storms. The stormwater quality volume for redevelopment sites are required to manage is the runoff from a 0.48 inch storm, which corresponds to the 80th percentile of all storms.

The methodology used in the EPA Report, [Estimating Predevelopment Hydrology in the Middle Rio Grande Watershed](#), New Mexico, TetraTech, April 2014, EPA Publication Number 832-R-14-007, yields runoff values of 0.42 inches for the 90th percentile storm and using the same methodology but generated from HEC-HMS, 0.26 inches for the 80th percentile storm.

Therefore, to calculate the required stormwater quality volume to be captured and infiltrated; multiply the impervious area by 0.42 inches for new development sites and 0.26 inches for redevelopment sites.

Stormwater Control measures shall be designed to manage the stormwater quality volume and control runoff generated by contributing surfaces.

For Single Family Subdivisions, stormwater quality ponds will not be allowed on individual lots. Instead a centralized stormwater quality pond for the entire subdivision must be constructed for the entire impervious areas to include the houses, patios, sidewalks, driveways, and public or private streets or a fee-in-lieu can be paid. Alternatively, to determine the amount of impervious area for Single Family Subdivision can use the following equation:

$$\text{EQUATION 7.60 Impervious percentage} = 7 \cdot \sqrt{(N \cdot N)} = (5 \cdot N)$$

**where:**

**N** = units/acre



For all developments, a combination of on-site/offsite ponding and Payment-in-lieu is allowed. For these cases, a Payment-in-Lieu waiver may be granted for the impervious areas not treated on-site by adequately sized stormwater quality facility.

## **Part. 6-13(A) Low Impact Development Strategies**

This section outlines principles to apply Low Impact Development strategies to effectively design stormwater quality features to treat the stormwater quality volume as part of the development process.

1. **Consider stormwater quality needs early in the design process.** This will provide for stormwater capture and treatment throughout the site rather than “shoe-horning” the facility resulting in a forced, constrained approach.
2. **Take advantage of the entire site when planning for stormwater treatment.** Spreading the runoff over a larger portion of the site can help to avoid less desirable treatment strategies that rely on underground capture and deep basins that can be difficult to maintain.
3. **Reduce runoff.** Drain impervious areas to landscape areas and minimize directly connected impervious areas. Reduce the amount of impervious areas (e.g. use porous pavement or gravel for low-use or emergency access) and select treatment techniques that promote infiltration.
4. **Integrate stormwater quality management and flood control, when practical.** If the site is required to detain runoff for flood control purposes, the facility used for flood control can be modified for stormwater quality by establishing the overflow elevation above the design standard volume.
5. **Landscape stormwater management facilities.** A stormwater management facility can be an attractive addition to the site, rather than just an unimproved dirt area. In addition, landscaping will minimize the potential for erosion and therefore minimize the amount of required maintenance.
6. **Consider surface conveyance** as an alternative to pipes.
7. **Design facilities for easier maintenance.** Fine soils may clog void spaces with time. The designer should consider a capture area for fine soils where stormwater enters the facility that can be easily replaced or maintained.
8. **Amend the soil** to allow for improved infiltration.

## **Part. 6-13(B) Effective Strategies for Stormwater Treatment**

There is a variety of methods to improve stormwater quality. Not all methods are appropriate for all development types. See [TABLE 6.12.15](#) for development types.

TABLE 6.13.15 Development Types				
Development Type	Percentage Landscaping	Percentage Parking/Paving	Building Footprint	Parking
Dense Urban	0-5%	0-5%	90-100%	On-Street Structure
High Density Mixed Use	0-10%	0-15%	80-90%	On-Street Structure and Surface
Commercial/Industrial	5-15%	40-60%	25-50%	Surface
Low Density Mixed Use	10-25%	30-50%	25-60%	Surface
Residential	30-70%	5-20%	30-70%	Surface
Educational/Institutional	15-60%	10-25%	25-60%	Surface
Parks/Open Space	80-95%	5-15%	0-10%	Surface

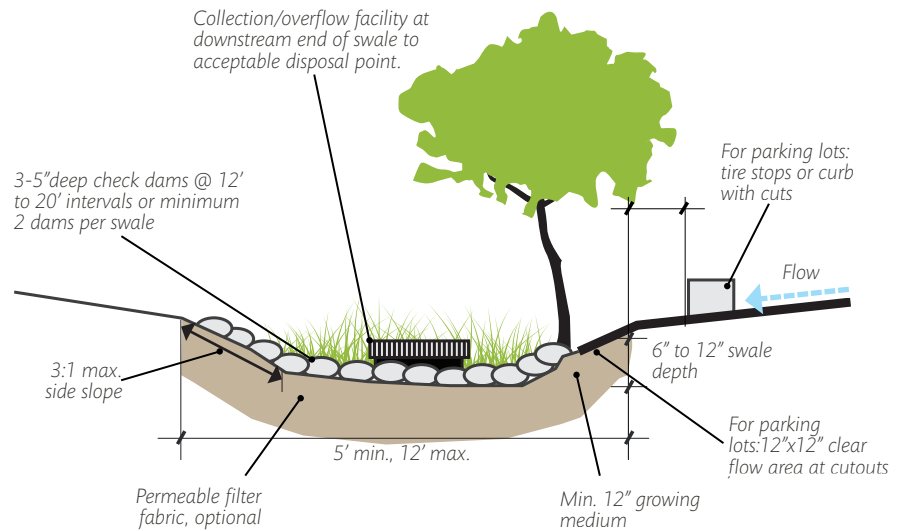
The following methods can be used to improve stormwater quality:

### Section. 6-13(B)(1) Landscape Category

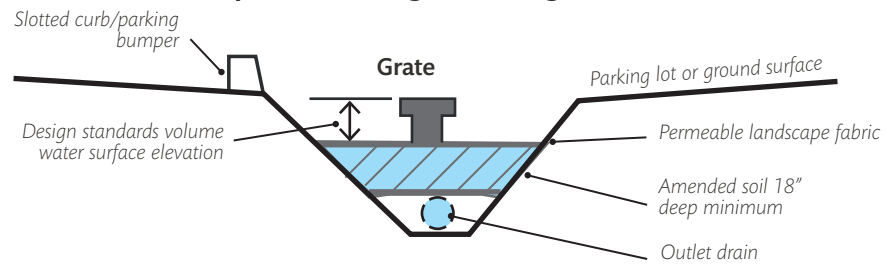
1. Depressed parking islands or planters with curb cut(s)

**NOTE:** If perforated pipe is used, the pipe is to be wrapped in landscape fabric.

FIGURE 6.13.29 Depressed Parking Island

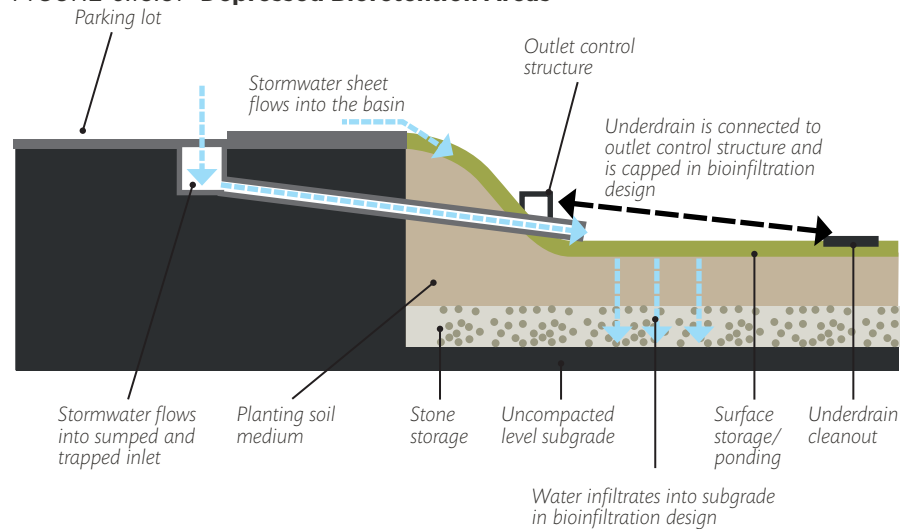


**FIGURE 6.13.30 Depressed Parking Island Diagram**



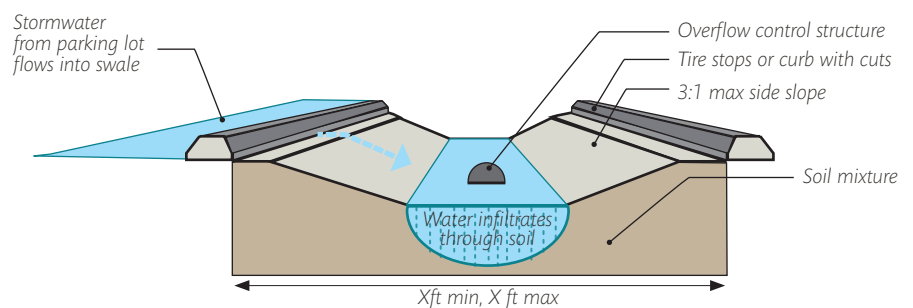
2. Depressed landscape/bioretention areas

**FIGURE 6.13.31 Depressed Bioretention Areas**



3. Landscape Conveyance-Bioswale

**FIGURE 6.13.32 Landscape Conveyance-Bioswale**



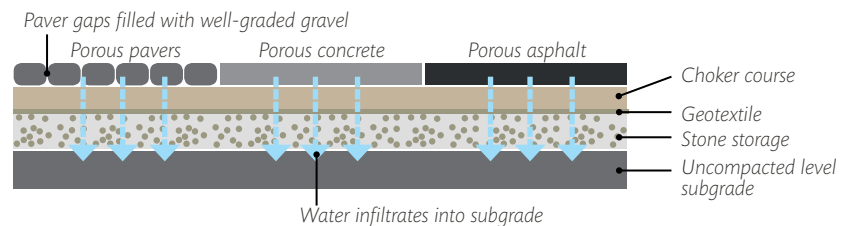
**NOTE:** Plants filter and transpire water while enhancing the parking lot.

4. Infiltration Trench
  - a. An infiltration trench is an effective means of capturing the design standard volume underground in the void space of the media (e.g. sand, rock). Maximum porosity (void space) to be used is 30%. A replaceable filter material (e.g. pea gravel, ) shall be used to prevent the build-up of fine material in the trench.
  - b. The length or width dimension must be greater than the depth dimension so that the trench is not considered an injection well.

### Section. 6-13(B)(2) Paving Category

1. Pervious pavers, concrete or asphalt
2. Open-cell structure with gravel
3. Gravel parking lots
4. Underground cisterns

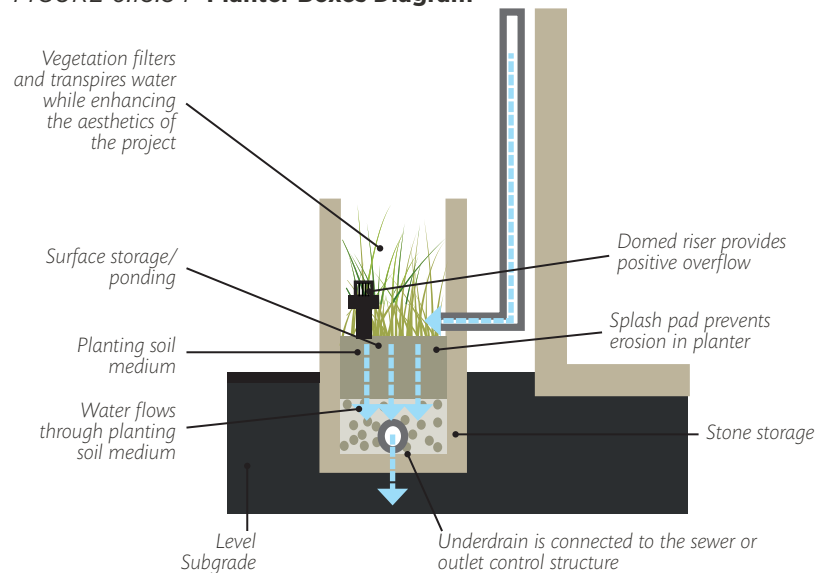
FIGURE 6.13.33 Porous Pavement with Typical Features



### Section. 6-13(B)(3) Elevated Category

1. Planter boxes
2. Cisterns
3. Green/brown roofs

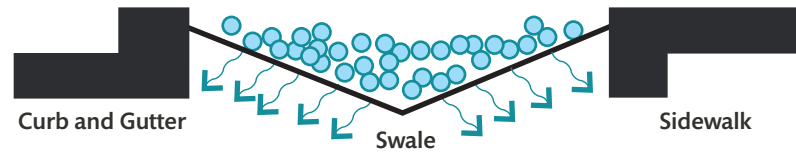
FIGURE 6.13.34 Planter Boxes Diagram



### Section. 6-13(B)(4) Streetscape Category

1. The landscape area between the sidewalk and back of curb is to be depressed and covered in rock to prevent erosion. See [City Of Albuquerque Standard Drawings](#) for construction details.

FIGURE 6.13.35 Swale Diagram



2. Street medians
  - a. On arterial streets, the designer may choose to drain the street into the median. Since this is a change from the City standard drawings, approval from the City Engineer is required. The minimum median width is 8 feet. Check dams will be required in the median on streets with slopes greater than 2.5% to reduce velocity.
  - b. The grate elevation is to be perched to allow the runoff from smaller storms to infiltrate.

### Section. 6-13(B)(5) Flood Control Category

The stormwater quality volume can be incorporated into a flood control facility by elevating the discharge point above the water surface elevation of the stormwater quality volume. In addition to managing the stormwater quality volume, flood control facilities shall remove trash and debris.

### Section. 6-13(B)(6) Offsite Mitigation Category

Constructing stormwater quality improvements outside the project boundaries is only available for projects that qualify for a Variance as discussed in [Part. 6-12\(C\)](#).

### Section. 6-13(B)(7) Payment-in-Lieu

After the alternative Variance criteria discussed later in this chapter is demonstrated, payment-in-lieu may be approved by the City Engineer. See [Part. 6-12\(C\)](#).

All development types are to manage the stormwater quality volume with one or more of the methods listed in [Part. 6-12\(A\)](#). [TABLE 6.12.15](#) shows the development types and which categories of methods are most appropriate.

**TABLE 6.13.16 Recommended Implementation Matrix**

Development Type	Landscape Category	Paving Category	Elevated Category	Streetscape Category	Flood Control Category	Off Site Mitigation Category	Payment-in-Lieu Category
Dense Urban		X	X	X		X	X
High Density Mixed Use	X	X	X	X		X	X
Commercial/Industrial	X	X	X	X	X		
Low Density Mixed Use	X	X		X	X		
Residential	X			X	X		
Educational/Institutional	X	X		X	X		
Parks/Open Space	X	X		X	X		

### **Part. 6-13(C) Variance from On-site Stormwater Quality Volume Requirements**

A waiver from constructing the stormwater quality facility required by this section may be granted when authorized by the City Engineer, on a case-by-case basis. If the City Engineer grants a waiver, a payment-in-lieu will be paid by the applicant as outlined in [Section. 6-12\(C\)\(1\)](#). Requests to waive the on-site stormwater quality facility requirements shall be submitted to Development & Review Services Division for Hydrology Section staff approval.

The requirements for on-site stormwater quality facility may be waived upon written request of the applicant, provided that one or more of the following conditions apply:

- a. *The lot is too small to accommodate management on site while also accommodating the full plan of development.*
- b. *The soil is not stable. This is to be demonstrated by a geotechnical report certified by a licensed Professional engineer in the State of New Mexico.*
- c. *Physical conditions exist where compliance with on-site stormwater quality control leaves insufficient area.*
- d. *Public or private off-site facilities provide an opportunity to effectively accomplish the mitigation requirements of the Drainage Ordinance. This must be shown by as-built construction drawings and an approved drainage report.*
- e. *The Developer constructs a project to replenish regional ground water supplies at an offsite location.*
- f. *A waiver to state water law or acquisition of water rights would be required in order to implement management on site. This volume is currently at 10 acre-feet, therefore capturing less than 10 acre-feet does not require a waiver.*

The project's Professional Engineer must sign the waiver request and a variance application must be submitted to the Development & Review Services Division for Hydrology Section staff approval.

In order to receive a waiver, the applicant must demonstrate to the satisfaction of the Development & Review Services Division for Hydrology Section that the waiver will not lead to the degradation of aquatic ecosystem or habitat condition downstream.

### **Section. 6-13(C)(1) Payment-in-Lieu**

The amount of Payment-In-Lieu is \$6/Cubic Foot for detached single family residential projects and \$8/cubic foot for all other projects. The fee is based on the total impervious area.

Payment-in-lieu is required for the difference between the amount met and total required.

Payment-in-lieu is waived for Metropolitan Redevelopment Areas or within the City of Albuquerque Annexation Boundary of 1950-1959.

Metropolitan Redevelopment Areas are shown on the Advanced Map Viewer, which is an internet based mapping program. The Advanced Map Viewer is located at the URL <https://www.cabq.gov/gis/advanced-map-viewer>.

The City of Albuquerque Annexation Boundary of 1950-1959 areas are shown in [FIGURE 6.12.36](#) through [FIGURE 6.12.40](#) at the end of this section.

An applicant will not have the option to pay a payment-in-lieu of constructing a stormwater quality facility if, in the opinion of the City Engineer, undetained runoff from the development may materially adversely exacerbate an existing problem.

### **Section. 6-13(C)(2) Annual Adjustment of Fee**

The fees shall be adjusted upward on every July 1 by multiplying the rates in effect on the prior July 1 by 100 percent of the percentage increase in the Consumer Price Index (CPI) for the 12-month period ending the preceding April. The fees shall remain the same in the event the CPI indicates a decrease. If the index ceases to be published on a monthly basis, the adjustment shall be based on the CPI for the most recent 12-month period. The CPI to be used shall be the Consumer Price Index – All Urban Consumers as published by the United States Department of Labor for the Albuquerque Metropolitan area.

### **Section. 6-13(C)(3) Payment of Fee**

Payment of the fee shall be made based on the following:

1. Multi-Family Development. Prior to the issuance of a building permit; or
2. Commercial Development. Prior to the issuance of a building permit; or
3. Single Family Subdivision. Prior to recording the final plat.

<b>TABLE 6.13.17 New Development</b>	
<b>Multi-Family and Commercial Minimum Stormwater Quality Fee</b>	
<b>Impervious Surface Area</b>	<b>Fee</b>
Less than 2,000 sq. ft.	\$600.00
2,000 – 4,000 sq. ft.	\$1,200.00
4,000 – 6,000 sq. ft.	\$1,800.00
6,000 – 8,000 sq. ft.	\$2,400.00
8,000 – 10,000 sq. ft.	\$3,000.00
10,000 – 15,000 sq. ft.	\$4,537.50
15,000 – 20,000 sq. ft.	\$6,050.00
20,000 – 25,000 sq. ft.	\$7,562.50
25,000 – 30,000 sq. ft.	\$9,075.00
30,000 – 35,000 sq. ft.	\$10,675.00
35,000 – 40,000 sq. ft.	\$12,200.00
40,000 – 45,000 sq. ft.	\$13,725.00
45,000 – 50,000 sq. ft.	\$15,250.00
50,000 – 55,000 sq. ft.	\$16,912.50
55,000 – 60,000 sq. ft.	\$18,450.00
60,000 – 65,000 sq. ft.	\$19,987.50
65,000 – 70,000 sq. ft.	\$21,525.00
70,000 – 75,000 sq. ft.	\$23,250.00
75,000 – 80,000 sq. ft.	\$24,800.00
80,000 – 85,000 sq. ft.	\$26,350.00
85,000 – 90,000 sq. ft.	\$27,900.00
90,000 – 95,000 sq. ft.	\$29,687.50
95,000 – 100,000 sq. ft.	\$31,250.00
100,000 – 150,000 sq. ft.	\$46,875.00
150,000 – 200,000 sq. ft.	\$63,000.00
200,000 – 250,000 sq. ft.	\$78,750.00
250,000 – 300,000 sq. ft.	\$95,250.00
300,000 – 350,000 sq. ft.	\$111,125.00
350,000 – 400,000 sq. ft.	\$128,000.00
400,000 – 450,000 sq. ft.	\$144,000.00
450,000 – 500,000 sq. ft.	\$161,250.00
500,000 – 550,000 sq. ft.	\$177,375.00
550,000 – 600,000 sq. ft.	\$195,000.00
600,000 – 650,000 sq. ft.	\$211,250.00
650,000 – 700,000 sq. ft.	\$229,250.00
700,000 – 750,000 sq. ft.	\$245,625.00
750,000 – 800,000 sq. ft.	\$264,000.00
800,000 – 850,000 sq. ft.	\$280,500.00
850,000 – 900,000 sq. ft.	\$299,250.00
900,000 – 950,000 sq. ft.	\$315,875.00



**TABLE 6.13.17 New Development**

950,000 – 1,000,000 sq. ft.	\$335,000.00
Greater than 1,000,000 sq. ft.	\$0.335 per sq.ft.

**TABLE 6.13.18 Redevelopment**

**Multi-Family and Commercial Minimum Stormwater Quality Fee**

<b>Impervious Surface Area</b>	<b>Fee</b>
Less than 2,000 sq. ft.	\$400.00
2,000 – 4,000 sq. ft.	\$800.00
4,000 – 6,000 sq. ft.	\$1,200.00
6,000 – 8,000 sq. ft.	\$1,600.00
8,000 – 10,000 sq. ft.	\$2,000.00
10,000 – 15,000 sq. ft.	\$3,037.50
15,000 – 20,000 sq. ft.	\$4,050.00
20,000 – 25,000 sq. ft.	\$5,062.50
25,000 – 30,000 sq. ft.	\$6,075.00
30,000 – 35,000 sq. ft.	\$7,175.00
35,000 – 40,000 sq. ft.	\$8,200.00
40,000 – 45,000 sq. ft.	\$9,225.00
45,000 – 50,000 sq. ft.	\$10,250.00
50,000 – 55,000 sq. ft.	\$11,412.50
55,000 – 60,000 sq. ft.	\$12,450.00
60,000 – 65,000 sq. ft.	\$13,487.50
65,000 – 70,000 sq. ft.	\$14,525.00
70,000 – 75,000 sq. ft.	\$15,750.00
75,000 – 80,000 sq. ft.	\$16,800.00
80,000 – 85,000 sq. ft.	\$17,850.00
85,000 – 90,000 sq. ft.	\$18,900.00
90,000 – 95,000 sq. ft.	\$20,187.50
95,000 – 100,000 sq. ft.	\$21,250.00
100,000 – 150,000 sq. ft.	\$31,875.00
150,000 – 200,000 sq. ft.	\$43,000.00
200,000 – 250,000 sq. ft.	\$53,750.00
250,000 – 300,000 sq. ft.	\$65,250.00
300,000 – 350,000 sq. ft.	\$76,125.00
350,000 – 400,000 sq. ft.	\$88,000.00
400,000 – 450,000 sq. ft.	\$99,000.00
450,000 – 500,000 sq. ft.	\$111,250.00
500,000 – 550,000 sq. ft.	\$122,375.00
550,000 – 600,000 sq. ft.	\$135,000.00
600,000 – 650,000 sq. ft.	\$146,250.00
650,000 – 700,000 sq. ft.	\$159,250.00

**TABLE 6.13.18 Redevelopment**

700,000 – 750,000 sq. ft.	\$170,625.00
750,000 – 800,000 sq. ft.	\$184,000.00
800,000 – 850,000 sq. ft.	\$195,500.00
850,000 – 900,000 sq. ft.	\$209,250.00
900,000 – 950,000 sq. ft.	\$220,875.00
950,000 – 1,000,000 sq. ft.	\$235,000.00
Greater than 1,000,000 sq. ft.	\$0.235 per sq.ft.

## **Part. 6-13(D) Land Uses that Require Additional Stormwater Controls**

### **Section. 6-13(D)(1) Automotive Repair and Parts Shops**

These land uses include shops that repair any portion of a vehicle (e.g. automotive body shops, general automotive repair) and retail automotive parts stores that have parking for customers. The exterior impervious area of these land uses shall drain to a surface stormwater quality facility that will remove pollutants from the stormwater prior to discharge into the street or drainage facility.

### **Section. 6-13(D)(2) Restaurants and Commercial Food Processing**

These land uses shall provide a drain in the trash enclosure that drains to the sanitary sewer after passing through a grease trap.

### **Section. 6-13(D)(3) Gas Stations/Fueling Facilities**

These land uses shall provide treatment for the area at the gas pumps, which is usually the same area as the canopy. The drainage/wash water from this area shall enter an area inlet(s), then be treated by a sand filter or similar prior to discharge into the street or drainage facility.

## **Part. 6-13(E) Post-Construction Maintenance and Responsibilities**

The following Post-Construction Maintenance and Responsibilities shall be performed in perpetuity:

Private Stormwater Facilities shall be maintained and inspected per the City approved drainage submittal by the facilities' (property) owner or responsible party. Stormwater quality facilities shall be identified on the City approved drainage submittal and recorded by standard form Covenant with the County Clerk.

The Covenant is required prior to issuance of Permanent Certificate of occupancy for commercial projects and prior to building permit approval for single

family residential projects as identified on the City approved drainage submittal.

The property owner may choose to document the stormwater quality facility requirements on the plat including benefit and maintenance responsibility language as identified on the City approved drainage submittal.

### **Section. 6-13(E)(1) City Post-Construction Inspections**

The City will conduct post construction site inspections to ensure the stormwater quality features of a site are being maintained in accordance with the approved drainage submittal.

## **Part. 6-13(F) Construction Site Responsibility By Property Owner**

All grading within the City of Albuquerque must be performed in a manner which prevents the movement of significant and damaging amounts of sediment onto adjacent property and public facilities by both water and wind, and minimizes the impacts to stormwater runoff quality.

To conform with EPA stormwater regulations, the property owner and general contractor must file an eNOI with the EPA for sites disturbing 1 acre or more of land, or is part of a larger common plan of development that will disturb greater than one acre of land, 14 days prior to commencing earth disturbing activities.

The property owner is to provide the certified Construction General Permit Electronic Notice of Intent documentation that contains the property owner name and contact information to the City a minimum of 14 days prior to earth disturbance and prior to obtaining Work Order or Building Permit (includes all permits; e.g. wall, foundation, etc...) approval.

If the eNOI is a Low Erosivity Waiver by the contractor, then an Erosion and Sediment Control Permit is to be approved by the City.

In addition, a City issued Erosion and Sediment Control (ESC) is required prior to earth disturbance or construction on projects that disturb less than one acre and are not part of a larger common plan of development of land or the following:

1. The site is identified as having a significant potential for erosion, based on observation or site characteristics including very steep (8% or greater) topography.
2. The site is known to contain contaminated soils.
3. The site is directly adjacent to receiving waters such as directly connected storm drains, directly connected concrete arroyos or the Rio Grande.
4. The site contains a building to be demolished and the building is 10,000 square feet or larger and was built or renovated prior to January 1, 1980.

The ESC Permit is to be approved prior to The City approving a Building Permit(s) or Work Order for the project.

1. The ESC Permit can be issued for earth disturbance and for Building Permit individually or together. The ESC Permit is the responsibility of the property owner.
2. The following approvals are required in advance of City approval of the ESC Permit:
  - a. *Grading and Drainage Plan,*
  - b. *Erosion and Sediment Control Plan*
  - c. *Floodplain Development Permit, if construction activities will occur in a mapped floodplain.*
3. BMPs identified on the ESC plan are to be in place prior to earth disturbance/construction. If the ESC plan is implemented in phases, the BMPs identified for that phase are to be in place prior to earth disturbance/construction for that phase.
4. A permit application is available online or at the City Engineer's office.
5. For sites that are part of a larger common plan of development, the last lot or pad site in the development will not need an ESC Plan if it is less than 0.45 acres.

## **Part. 6-13(G) Construction Site Maintenance and Inspections**

1. Self-inspections by permittee. Sites are to be inspected by the property owner or designee for compliance with the Construction General Permit once every 14 days and after a precipitation event of  $\frac{1}{4}$  inch or greater. Inspection results are to be documented on a report. Reports are to include applicable items from the Construction general Permit.
2. Self-inspection reports are to be provided to the City upon request.
3. The City will conduct inspections of construction sites for compliance with the EPA NPDES Construction General Permit and the Drainage Ordinance.
4. Sites located in priority areas will be inspected by the City more frequently. A site is located in a priority area if the site drains to a Waters of the U.S. without passing through a public detention or retention facility that removes sediment, debris and floatables between and the Rio Grande river.

**FIGURE 6.13.36 City of Albuquerque Annexation Boundary of 1950-1959.**

See later figures for street names and location details.

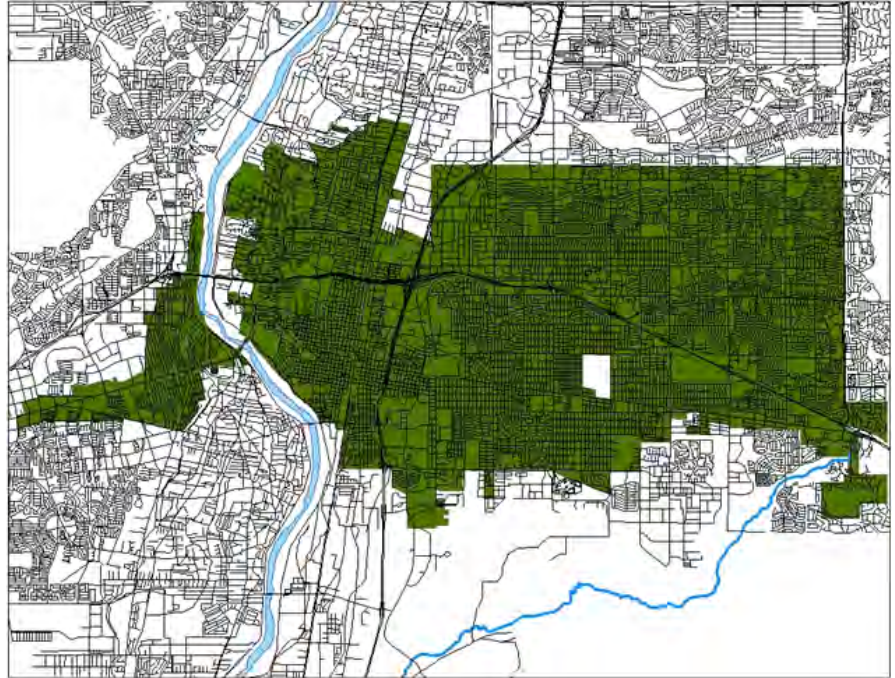


FIGURE 6.13.37 City of Albuquerque Annexation Boundary of 1950-1959 West Area



FIGURE 6.13.38 City of Albuquerque Annexation Boundary of 1950-1959 West 2 Area





FIGURE 6.13.39 City of Albuquerque Annexation Boundary of 1950-1959 West 3 Area

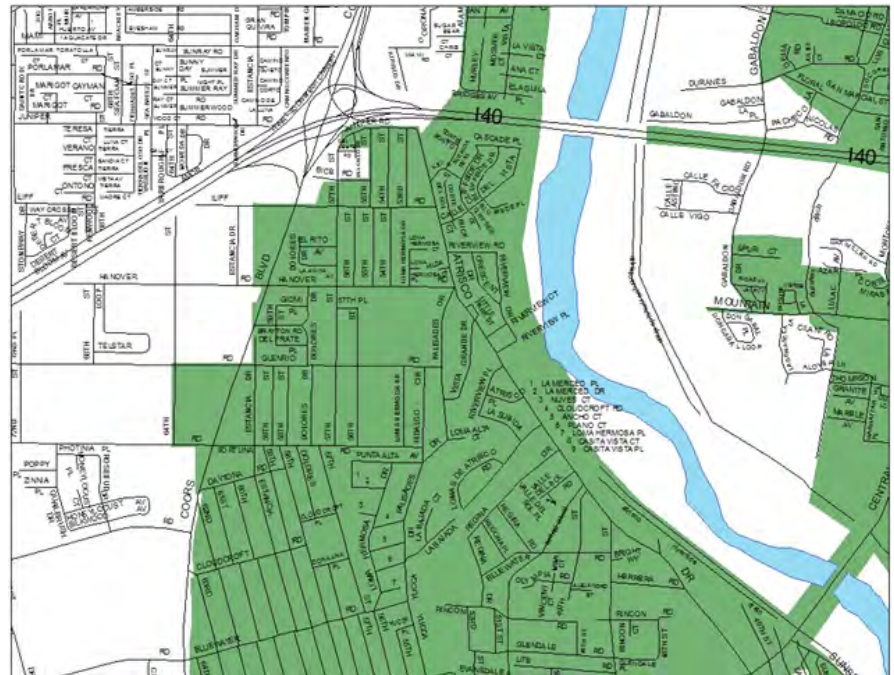


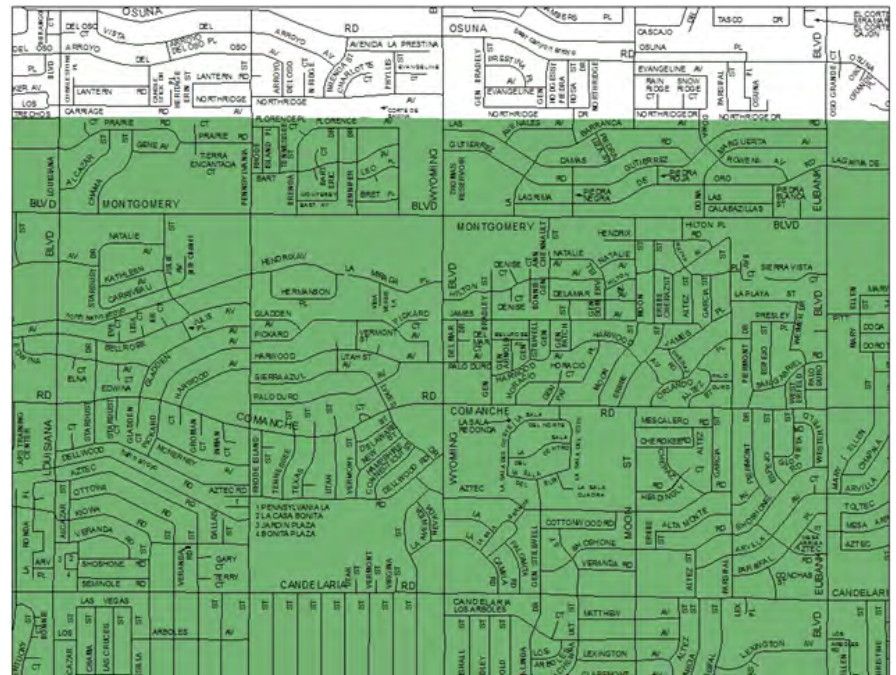
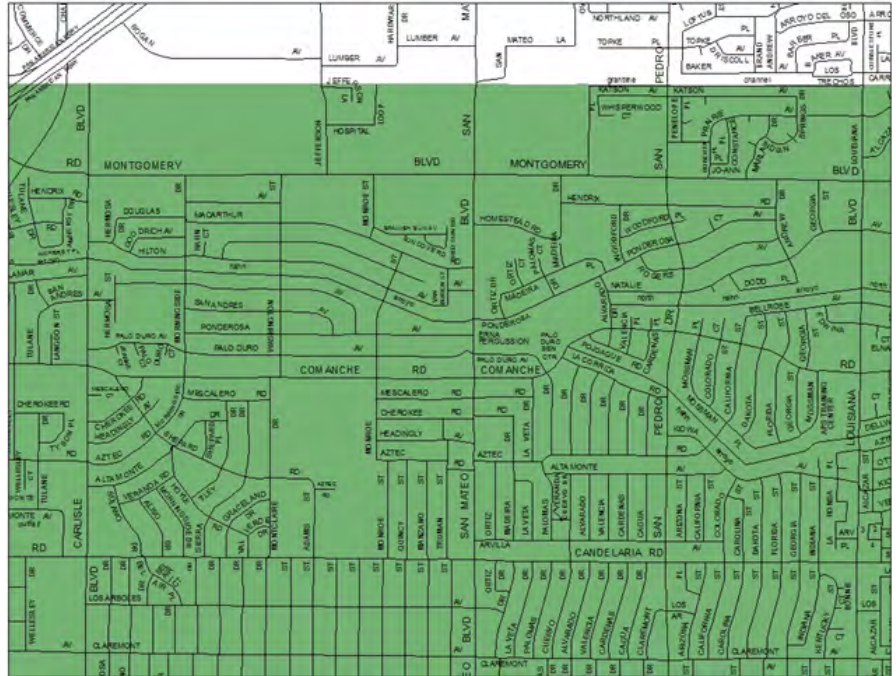
FIGURE 6.13.40 City of Albuquerque Annexation Boundary of 1950-1959 140 Area

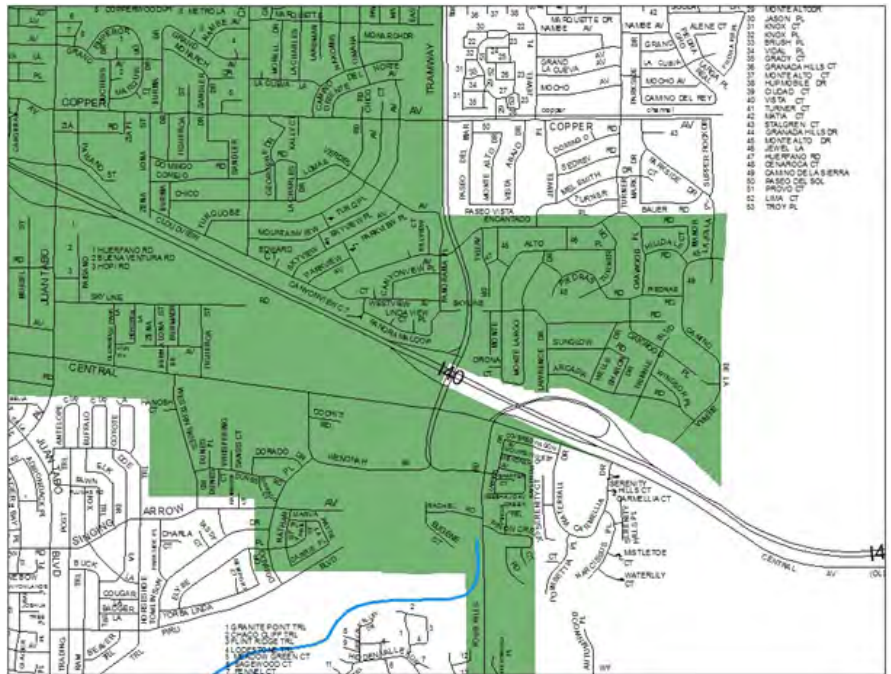
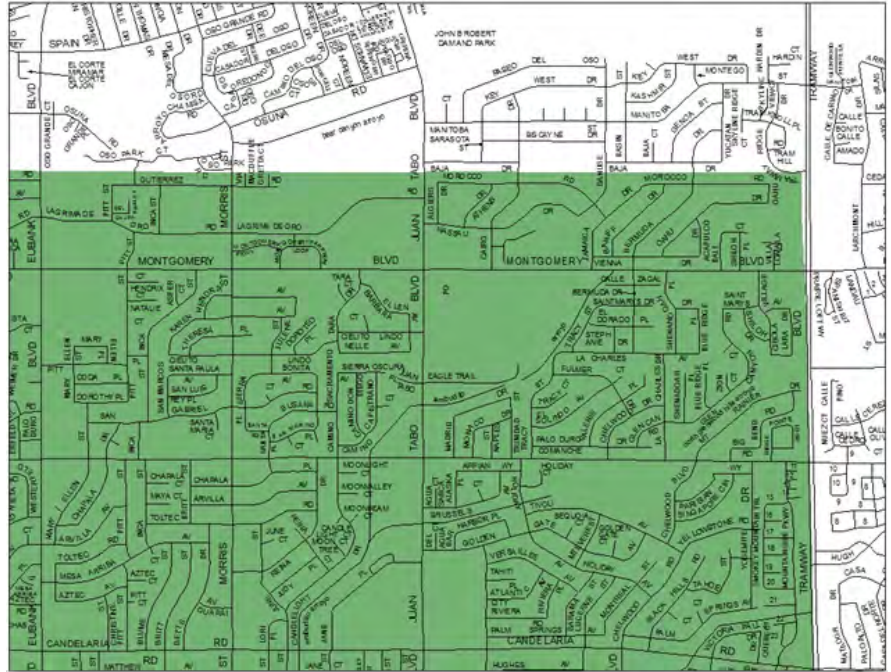




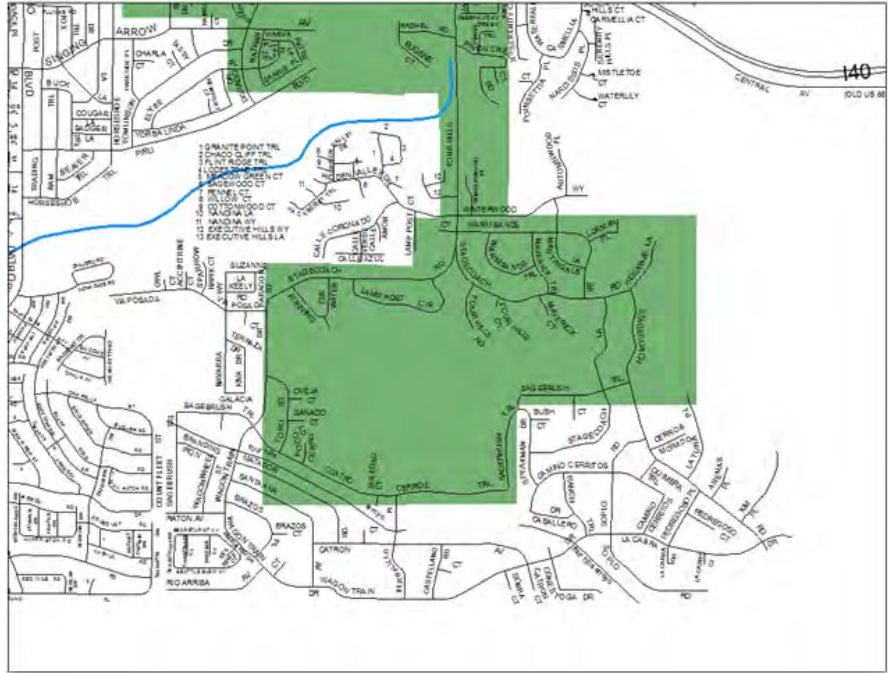


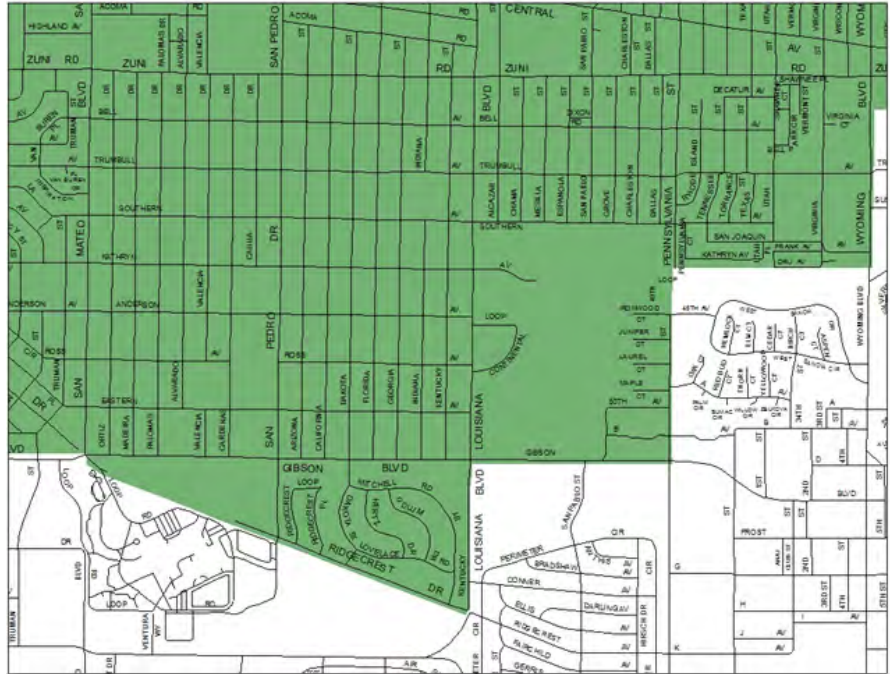




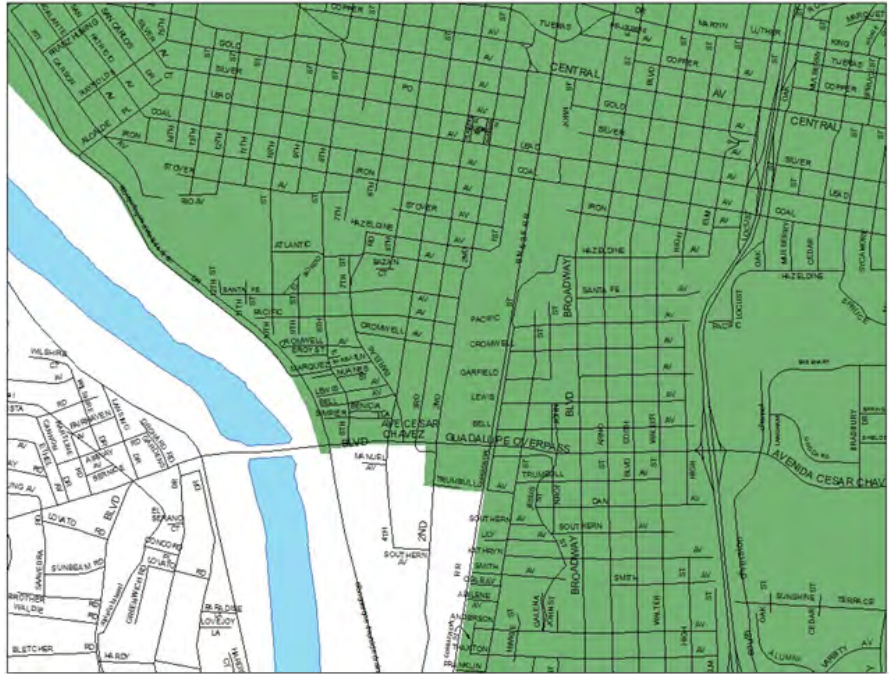














## **ARTICLE 6-14 DRAINAGE RIGHT-OF-WAY AND EASEMENTS**

### **Part. 6-14(A) Rights-of-Way**

Whenever no beneficial use can be derived by an owner from continued retention of that land necessary for permanent drainage, flood control or erosion control facilities or when the facilities involve a major arroyo, the land required for the operation and maintenance of the facilities must be dedicated to AMAFCA or the City. Maintenance responsibility of the facilities must be clearly defined.

### **Part. 6-14(B) Easements**

Easements for drainage, flood control and erosion control facilities are acceptable (except where prohibited in Subsection 22.12.1 above) as long as a clear agreement exists as to other acceptable uses and that no other permanent facilities (e.g. non-drainage facilities) are constructed within them (including masonry fences and retaining walls but excluding pavement) without an agreement between the owner and the City, governing the permitted uses. Maintenance responsibility of the facilities must be clearly defined. Easements can be shown on a plat or be provided by a paper easement. Paper easements are processed through the Design Review and Construction Services section.

### **Part. 6-14(C) Configuration**

Rights-of-way and permanent easements required for drainage, flood control and erosion control facilities will conform to the following criteria:

#### **Section. 6-14(C)(1) Surface Facilities**

The dedicated area should contain the entire facility including any slopes, maintenance roads, turn arounds or other necessary appurtenances. Easement width shall be sufficient to allow for maintenance activities. Public Easements must be a minimum of 10 feet wide

#### **Section. 6-14(C)(2) Public Underground Facilities**

Dedicated areas for Public underground facilities shall not be narrower than 20 feet for any drainage facility and must conform to the following formula, unless otherwise approved by the City Engineer:

**EQUATION 7.61**  $W = 2 \times D_s + \text{pipe diameter or box culvert width} + 4 \text{ feet}$

**where:**

**W** = dedicated width in feet

**D<sub>s</sub>** = depth to bottom of the structure (invert + thickness of the structure)



Outside dimensions must be used for pipe diameter and box culvert width. Other utilities shall not be permitted within the trench prism of the drainage facility.

### **Part. 6-14(D) Drainage Right-of-Way and Public Drainage Easement Access**

All newly constructed surface drainage facilities within a public right-of-way or Public Drainage Easement must be blocked off at both ends to prevent unauthorized vehicular access with City Standard Tube Gate or removable bollards.

### **Part. 6-14(E) Private Storm Drain Improvements Within City Right-of-Way and/or Easements**

Frequently, a drainage plan developed for a particular property involves either discharge directly into a public facility or across a portion of a public right-of-way to a public facility.

Examples include connections to the back of an existing storm inlet, construction of sidewalk culverts or a connection to a storm drain manhole or a channel. When such solutions are employed the construction of private storm drain improvements within the City Right-of-Way must comply with the following requirements:

1. The proposed improvement must be incorporated on the grading and drainage plan. This plan must include the design or City standards to be used and the location of the proposed construction in the City Right-of-Way.
2. An excavation/construction permit will be required before beginning any work within the City's Right-of-Way. An approved copy of the grading and drainage plan must accompany the excavation/construction permit request.
3. All work to be performed within the public Right-of-Way or easement shall be constructed in accordance with City of Albuquerque Standard Specifications for Public Works Construction.
4. Prior to construction, the contractor shall excavate and verify the horizontal and vertical locations of all constructions to identify a conflict. Should a conflict exist, the contractor shall notify the engineer so that the conflict can be resolved with a minimum of delay.
5. Backfill compaction shall be according to City of Albuquerque Standard Specifications for Public Works Construction.
6. The facility is to be inspected and accepted by the City prior to obtaining a Permanent Certificate of Occupancy.
7. Maintenance of these facilities shall be the responsibility of the owner of the property served.
8. Notes 1 through 7 listed above are to be placed on the grading and drainage plan for approval by the Hydrology Section of the Planning Department..

## **ARTICLE 6-15 DRAINAGE AND STORMWATER QUALITY SUBMITTALS**

### **Part. 6-15(A) Introduction**

A drainage and stormwater quality submittal is generally in the form of a Conceptual Grading and Drainage Plan, Drainage Report, Grading and Drainage Plan, Erosion and Sediment Control Plan, LOMR, CLOMR or LOMR-F. The following are definitions of these types of submittals:

#### **Section. 6-15(A)(1) Drainage Report**

A Drainage Report is a comprehensive analysis of the drainage management, flood control, erosion control constraints on and impacts resulting from the proposed platting, development or construction of a particular project.

#### **Section. 6-15(A)(2) Conceptual Grading and Drainage Plan**

The purposes of this plan are to check the compatibility of the proposed development within grading, drainage, floodplain, erosion control and stormwater quality as dictated by onsite physical features as well as adjacent properties, streets, alleys and channels. Unless otherwise approved by the City Engineer, a Conceptual Grading and Drainage Plan is required for EPC and DRB approval, but is lacking detail necessary to be used for construction.

#### **Section. 6-15(A)(3) Grading and Drainage Plan**

A Grading and Drainage Plan is a comparatively short, yet comprehensive, presentation for small, non-complex development submittals. Grading and Drainage Plans address both onsite and offsite drainage management, flood control, erosion control and stormwater quality. An approved Grading and Drainage Plan is required prior to Grading Permit (2-6.5), Paving Permit (2-6.5), SO-19 Permit (2-7.10), Floodplain Development Permit (2-6.2), Building Permit, and Work Order.

#### **Section. 6-15(A)(4) Erosion and Sediment Control Plan**

An Erosion and Sediment Control (ESC) plan provides necessary information to prevent erosion and sediment deposition in city streets and drainage facilities during the construction phase of a project. Necessary information includes erosion and sediment control Best management Practices (BMPs) as well as keyed notes. Typical BMPs include inlet protection, silt fence, mulch socks or wattles, erosion control mats, tackifier and a stabilized construction entrance (track-out pad).

#### **Section. 6-15(A)(5) LOMR, CLOMR and LOMR-F (LOMC) submittals**

Documents that are submitted to FEMA to change a mapped flood zone or remove property or a structure from a flood zone are described in Section 5. A

Floodplain Development Permit (2-6.2) is required prior to development in a Special Flood Hazard Area (SFHA).

**Section. 6-15(A)(6) Engineer’s Certifications**

Engineer’s Certifications are as-built grading plans and/or as-built grading and drainage plans that are required prior to release of financial guarantee for subdivisions and prior to release for Certificate of Occupancy for commercial developments. After all of the grading and drainage construction is complete the engineer certifies that it is complete and is in substantial compliance with the approved plan.

**Section. 6-15(A)(7) Pad Certification**

A Pad Certification is an Engineer’s Certification that can be submitted if a property owner desires to request Building Permit approval in a mass graded subdivision in advance of all infrastructure being completed/accepted or in cases where Hydrology requires verification of the pad elevation prior to Building Permit approval. Examples of this are flood zones and SAD 228. The table below provides a matrix to aid property owners and consultants to determine which form of drainage submittal to submit to the City based upon the approval sought:<sup>6</sup>

**Section. 6-15(A)(8) Drainage and Erosion and Sediment Control Submittals for Approval Sought**

The table below provides a matrix to aid property owners and consultants to determine which form of drainage submittal to submit to the City based upon the approval sought.

**TABLE 6.15.19 Drainage Submittals for Approval Sought**

Approval Sought	Conceptual Grading & Drainage Plan	Drainage Report	Grading & Drainage Plan	Engineer Certification	Erosion & Sediment Control Plan
EPC Site Plan	X				
DRB Site Plan					
For Building Permit	X	X <sup>5</sup>			X <sup>7</sup>
DRB Site Plan for Subdivision	X				
Plat: >10 lots or ≥ 5 acres		X	X		
Plat: <10 lots or ≤ 5 acres		X <sup>1</sup>	X <sup>1</sup>		
Building Permit		X <sup>2</sup>	X <sup>3</sup>		X <sup>7</sup>

**6** An “X” in a box in the table indicates the submittal is required, unless a note as discussed below the table, indicates otherwise.

**TABLE 6.15.19 Drainage Submittals for Approval Sought**

Approval Sought	Conceptual Grading & Drainage Plan	Drainage Report	Grading & Drainage Plan	Engineer Certification	Erosion & Sediment Control Plan
Private Facility Drainage Permit			X	X	
Drainage Master Plan		X			
Work Order Construction Plans		X <sup>5</sup>	X <sup>1</sup>		X <sup>7</sup>
Release of Financial Guarantee/ Final Plat				X <sup>4</sup>	
Construction in a Flood Zone(8)		X <sup>5</sup>	X	X	
Certificate of Occupancy				X <sup>6</sup>	

1. A grading plan or drainage report may not be required to obtain approval. Schedule a pre-design meeting with Hydrology to determine if a drainage submittal is required.
2. Projects 5 acres or larger shall require a drainage report. Smaller projects in complex drainage basins may also require a drainage report.
3. Some single family residential homes not located in a mass-graded subdivision may require a drainage submittal based on topography, Flood Hazard Zone designation, or site conditions.
4. The requirement to submit an engineer’s certification will be noted on the infrastructure list.
5. A drainage report may not be required for non-complex sites. Schedule a pre-design meeting with Hydrology to determine if a drainage report is required.
6. An Engineer’s Certification is required if an approved grading plan was required prior to earth disturbance, except for single family residential homes that are part of a mass graded subdivision.
7. See **Section 11** for the criteria when an Erosion and Sediment Control Plan is required.
8. All projects in a flood zone require a Floodplain Development Permit and most will require a submittal to FEMA.
9. An Engineer’s Certification or Pad Certification is required prior to Building Permit for each single family residential lot for which an approved Grading Plan is required.

### **Part. 6-15(B) Drainage Submittal Criteria**

Each submittal shall include the following information:

1. Project Name
2. Name of Engineering Firm

3. Engineer's Seal (signed and dated)
  4. Completed Drainage Information Sheet
- Information is identified in the outline below: <sup>7</sup>

### **Section. 6-15(B)(1) Executive Summary**

1. Provide a brief yet comprehensive discussion of the following:
  - a. *General project location*
  - b. *Development concept for the site*
  - c. *Drainage concept for the site (include relevant numbers as appropriate)*
  - d. *How offsite flows will be handled*
  - e. *How onsite flows will be handled and discharged*
  - f. *Downstream capacity and how determined*
  - g. *Impacts on or requirements of other jurisdictions*
  - h. *How stormwater quality volume will be managed*
2. Identify all approvals being requested in conjunction with this submittal, such as:
  - a. *Zone Change*
  - b. *Subdivision Plat*
  - c. *Site Plan for Subdivision*
  - d. *Site Development Plan for Building Permit*
  - e. *Building Permit*
  - f. *Private Facility Drainage Permit*
  - g. *Grading Permit*
  - h. *Paving Permit*
  - i. *DPM Design Variance*
  - j. *CLOMR, LOMR or LOMA*

### **Section. 6-15(B)(2) Introduction**

1. Narrative description of project scope
  - a. *Provide more detail than presented in the Executive Summary (combine with Executive Summary for non-complex projects)*
2. Project requirements
  - a. *Discuss and reference required infrastructure and associated infrastructure list*
  - b. *Platting and/or easements*
  - c. *Approvals by and/or coordination with other Agencies and/or entities*
3. Attachments (when applicable)
  - a. *Infrastructure List (draft, preliminary, amended or approved)*
  - b. *Preliminary or Final Plat*
  - c. *Easement Documents*
  - d. *Drainage Covenants*
  - e. *Approval Letters*

---

**7** *The following Outline is intended only as a guide for the preparation of Drainage Submittals. Some items may not be applicable, while other items may require a more in-depth treatment. A Pre-design Conference is recommended for projects where the scope may be difficult to define, the constraints and conditions somewhat unique, or the drainage solution non-traditional.*

*The allowable discharge from a particular project shall be determined based upon available downstream capacity as defined by the Drainage Ordinance. In certain cases, the allowable discharge shall be based upon the value(s) set forth in previously approved and/or adopted Drainage Management Plans, Drainage Plans reports or studies.*

### **Section. 6-15(B)(3) Project Description**

1. Location
  - a. Discuss relationship of the site to the following:
    - i Well known landmarks
    - ii Municipal limits
    - iii City Zone Atlas page and reference
    - iv Other jurisdictional boundaries
    - v Previously approved Drainage Management Plans, Drainage Reports, Plans or studies including watersheds, basins, drainage-ways, etc. as defined therein
  - b. Provide copy of Zone Atlas page, or equivalent, with the site location superimposed
2. Legal Description
  - a. Identify the current legal description(s) of the land which comprises the site
  - b. Identify the proposed legal description(s), when applicable, of the land which comprises the site
  - c. Include a copy of existing and/or proposed platting as an attachment in cases where its inclusion will lend clarity or facilitate the review
3. Flood Hazard Zone
  - a. Identify proximity of site to a designated Flood Hazard Zone
  - b. Provide reference to the above referenced Flood Hazard Zone
  - c. Identify whether or not the site drains to or has an adverse impact upon a designated Flood Hazard Zone
  - d. Include a copy of the relevant FEMA Flood Insurance Rate Map (FIRM) or Flood Boundary and Floodway Map with the site clearly identified along with all affected Flood Zones
  - e. Identify portion of designated Flood Hazard Zone to be revised or amended when CLOMR, LOMR or LOMA approval requested.

### **Section. 6-15(B)(4) Background Documents**

1. Planning History
  - a. Reference and discuss relevant Planning and Zoning actions, plans or studies
  - b. Verify and/or demonstrate compatibility with the above actions, plans and studies
2. Drainage History and Related Documents
  - a. Reference and discuss relevant Drainage Management Plans, Drainage Plans, Reports and Studies
  - b. Reference applicable Hydrology File, PWD (DRC) Project and DRB Project numbers
  - c. Discuss status of above referenced Plans, Reports and Studies
  - d. Describe compatibility with or deviation from the above referenced Plans, Reports and Studies
  - e. Describe the location of site with respect to previously defined watersheds or drainage basins
  - f. Provide copies of pertinent data from above referenced Plans, Reports and/or Studies when applicable

### **Section. 6-15(B)(5) Existing Conditions**

1. Site Investigation
  - a. Describe by text or clearly show graphically the following:
    - i onsite drainage patterns

- ii onsite drainage facilities
  - iii point(s) of discharge
  - iv drainage basin(s) boundaries
  - v offsite drainage facilities
  - vi offsite drainage patterns including offsite flow conditions
  - vii condition and status of adjacent properties (e.g. developed, undeveloped, under construction, etc.)
  - viii condition and status of adjacent right-of-way (e.g. developed, undeveloped, under construction, etc.)
  - ix presence of any other relevant features
2. Site Evaluation
- a. Discuss the significance and impacts of the following:
    - i onsite drainage facilities
    - ii offsite drainage facilities
    - iii point(s) of discharge
    - iv drainage basin(s) boundaries
    - v offsite flow conditions
    - vi proximity to designated flood hazard zone(s)
    - vii presence of any other relevant features or conditions which may impact or be impacted by the development of the property or project
  - b. Form of Analysis
    - i Most situations - most submittals require both qualitative and quantitative analyses
    - ii Unique situations - for some cases, such as infill sites, a qualitative analysis by itself may be appropriate. Examples of appropriate qualitative analysis criteria are
      - (1) a comparison of the runoff generated by the proposed development to that generated by the overall drainage basin with respect to the impacts of the anticipated increase
      - (2) impacts on downstream flood plains
      - (3) potential offsite problems which may or may not be attributed to this development
      - (4) anticipated impact(s) and/or precedent to be set on the development of the remaining infill sites by following the same drainage concept
  - c. Downstream Capacity. Downstream capacity is discussed in Section 6. (The evaluation of downstream capacity shall include, but not be limited to, the following:)
    - i Assumptions
      - (1) fully developed watershed
      - (2) ability to accept and safely convey runoff generated from the 100-year design storm
    - ii Hydraulic capacity
      - (1) channel
      - (2) crossing structure
      - (3) storm inlet and/or entrance conditions
      - (4) storm drain
      - (5) street and/or alley
    - iii Storage capacity
      - (1) Detention pond/reservoir
      - (2) Retention pond
      - (3) Flood zone
    - iv Stability



- (1) Channel/arroyo
- (2) Natural slope
- (3) Cut/fill slope

### **Section. 6-15(B)(6) Developed Conditions**

1. Onsite
  - a. Discuss the following as applicable:
    - i proposed development/construction
    - ii impacts on existing drainage patterns
    - iii impacts on existing drainage basins
    - iv impacts on existing onsite facilities
    - v identification of offsite flow conditions
    - vi compatibility/compliance with previously approved and/or adopted Plans, Reports and Studies
    - vii sediment bulking
    - viii aggradation and/or degradation potential
    - ix impacts on designated flood hazard zones (A Zones only)
    - x required private drainage improvements
    - xi required infrastructure
    - xii required easements
    - xiii phasing and future improvements
    - xiv ownership, operation and maintenance responsibilities
    - xv stormwater quality basins and corresponding facility
  - b. Evaluate and/or quantify the following:
    - i capacity and freeboard of existing onsite facilities
    - ii capacity and freeboard of proposed onsite facilities
    - iii impacts on designated flood hazard zones
    - iv impacts on existing drainage patterns and drainage basin boundaries
    - v impact of offsite flows on the proposed development
    - vi erosion potential and erosion setback requirements
    - vii phased system capacities and ability to function as a stand alone system
    - viii emergency overflow spillway conditions
2. Offsite
  - a. Discuss the following:
    - i impacts on existing drainage basins and/or watersheds
    - ii impacts on existing offsite facilities and downstream capacity
    - iii compatibility/compliance with previously approved and/or adopted Plans, Reports and Studies
    - iv impacts on designated flood hazard zones
    - v required improvements
    - vi required easements
    - vii right-of way dedications
    - viii phasing and future improvements
    - ix ownership, operation and maintenance responsibilities
    - x concurrence and/or approval from affected property owners for offsite grading or construction activities
  - b. Evaluate and/or quantify the following:
    - i capacity of existing offsite facilities
    - ii capacity of proposed offsite facilities
    - iii impacts on downstream designated flood hazard zones
    - iv impacts on downstream drainage basins and/or watersheds

v downstream capacity

### **Section. 6-15(B)(7) Grading Plan**

1. Description
  - a. *Reference the Grading Plan when included as an attachment to the Drainage Submittal*
  - b. *Describe elements of the Plan and how those elements relate to the Existing and Developed Conditions sections of the submittal discussed above*
  - c. *Discuss and reference all other supporting drawings provided in support of the Drainage Submittal*
2. Content
  - a. *Refer to Grading Plan Checklist that follows.*

### **Section. 6-15(B)(8) Calculations**

1. Description
  - a. *Provide narrative description of the calculations performed to support the analyses and evaluations discussed above*
  - b. *Discuss and reference calculations for Existing, Developed and Future hydrology*
  - c. *Discuss and reference hydraulic calculations demonstrating capacity and/or adequacy of existing and proposed facilities*
  - d. *Provide sample calculations, tables, charts, etc. as necessary to support the calculations and results discussed above*
  - e. *Reference computer software, documents, circulars, manuals, etc. used to produce the calculations and results discussed above*

### **Section. 6-15(B)(9) Conclusion**

1. Summary of proposed drainage management strategy
2. Justification of rationale for discharge of developed runoff from site
3. Summary of proposed drainage improvements
4. Identification of DPM design variances being requested
5. Identification of required Drainage Covenants
6. Identification of ownership, operation and maintenance responsibilities

## **Part. 6-15(C) Grading Plan Checklist**

The following checklist is intended only as a guide for preparing a Grading Plan to accompany a drainage report or plan. Some items may not be applicable to your particular project; some items may require more detail. A pre-design conference is recommended to define scope and project specific requirements.

### **Section. 6-15(C)(1) General Information**

1. Professional Engineer's stamp with signature and date.
2. Drafting Standards: (Reference City Standards, DPM V. 2, Chapter 27).
  - a. North Arrow
  - b. Scales - recommended engineer scales:
    - i 1" = 20' for sites less than 5 acres
    - ii 1" = 50' for sites 5 acres or more
  - c. Legend - see D.P.M. Manual, Volume 2, Tables 27.3a - 27.3d for recommended standard symbols

- d. Plan drawings size: 24" x 36"
        - e. Notes defining property line, asphalt paving, sidewalks, planting areas, ponding areas, project limits, and all other areas whose definition would increase clarity
3. Vicinity Map
4. Benchmark - location, description and elevation
  - a. Albuquerque control survey vertical datum
  - b. Permanently marked temporary benchmark on or very near site
5. Flood Hazard Boundary Map (FHBM) or Flood Insurance Rate Map (FIRM)
6. Legal Description

## **Section. 6-15(C)(2) Existing Conditions**

### **6-15(C)(2)(i) On-site**

1. Existing Contours - vertical intervals for contour maps shall not exceed the following:
  - a. One foot intervals for slopes under 1% with sufficient spot elevations at key points to adequately show the site's topography
  - b. Two feet for slopes between 1% and 5%
  - c. Five feet for slopes in excess of 5%
2. Spot elevations adequately showing conditions on-site.
3. Contours and spot elevations extending a minimum of 25' beyond property line.
4. Identification of all existing structures located on-site or on adjacent property extending a minimum of 25' beyond property line with particular attention to retaining and garden walls.
5. Identification of all existing drainage facilities located on-site or on adjacent property.
6. Pertinent elevation(s) of structures and facilities defined in A, B and C above with NGVD 29 designation. NGVD 29 is the vertical system on which ACS monuments are currently based. In the future, ACS monuments should be field converted to NAVD 88 at which time NAVD shall become "equivalent".
7. Indication of all existing easements and rights-of-way on or adjacent to the site with dimensions and purpose shown.
8. Existing City top of curb and flow line elevations with NGVD 29 designation, or equivalent.
9. The location of Special Flood Hazard Area Boundaries from the latest FEMA maps must be overlaid on the existing site map (enlarged to site plan scale), when applicable.
10. The topographic survey must be performed by a professional surveyor in accordance with the "New Mexico Engineering and Surveying Practice Act" as amended and any standards adopted by the State Board of Registration.

### **6-15(C)(2)(ii) Off-site**

1. Contributing Area - delineation of off-site contributing watersheds and/or drainage basins on City of Albuquerque Ortho-Topo Area Maps or equivalent mapping at a preferable scale of 1" = 200' or 1" = 500'. Watershed and Basin designations shall match those used in the hydrology calculations.
2. Existing easements and rights-of-way including ownership and purpose.

## Section. 6-15(C)(3) Proposed Conditions

### 6-15(C)(3)(i) On-site

1. Proposed improvements superimposed onto the existing conditions,
2. Proposed Grades. Proposed grades shall be adequately depicted by contours and/or spot elevations conforming with the following minimum criteria:
  - a. Contours - vertical intervals for contour maps shall not exceed the following:
    - i One foot intervals for slopes under 1% (with supplemental spot elevations as appropriate to adequately illustrate the proposed grading of the site).
    - ii Two feet for slopes between 1% and 5%.
    - iii Five feet for slopes in excess of 5%.
  - b. Spot Elevations - supply spot elevations at the following:
    - i Key points and grade breaks
    - ii Critical locations
    - iii Pad elevations
3. Indication of all proposed easements and rights-of-way on or adjacent to the site with dimensions and purpose identified.
4. City Engineer approved street and/or alley grades when site abuts a dedicated unpaved street or alley. In the event that approved grades are not available, provide preliminary street and/or alley grades.
5. Internal contributory drainage areas, including roof areas, outlined on plan.
6. Flow lines defined by arrows and spot elevations with NGVD 29 designation, or equivalent, as appropriate for clarity.
7. Pond(s) 100 year water surface elevation outlined and indicated on plan.
8. Finish building floor elevation(s) or pad elevation(s) with complete NGVD 29 designation, or equivalent, when applicable.
9. Elevations along property lines including relationship to adjacent top of curb.
10. Details of ponds, inverts, rundowns, curb cuts, water blocks, emergency spillways, retaining walls, pond outlets, safety fences, slopes, and all other significant drainage structures with contours, cross-sections and spot elevations. All cross-sections must be drawn to a standard engineering scale and adequately dimensioned.
11. Phasing,
12. Proposed construction of private storm drain improvements within public right-of-way and/or easement including identification of the public entity having ownership.
13. Proposed contours superimposed over existing contours adequately demonstrating changes in grade especially at the property line
14. Identification of any required offsite grading
15. Specifications for the proposed grading and/or soil compaction

### 6-15(C)(3)(ii) Off-site

1. Definition, location, and configuration of required drainage facilities.
2. Rights-of-way and easements needed to accommodate (A) above.

## Part. 6-15(D) Erosion and Sediment Control Plan Checklist

Use this checklist to prepare an Erosion and Sediment Control (ESC) Plan. There are three types of approvals for an ESC Plan; ESC Permit for grading, ESC Permit for Building Permit, and Work Order Construction plans. A stormwater Quality Information Sheet is to be submitted with each ESC plan submittal.

1. Checklist for ESC plans to obtain an ESC Permit for Grading:
  - a. Site boundary.
  - b. Disturbed area boundary
  - c. Vicinity Map
  - d. New Mexico Professional Engineer stamp and seal.
  - e. Sediment barrier BMPs
  - f. Erosion control BMPs
  - g. Inlet protection
  - h. Stabilized Construction entrance or exit (not located at drainage outfall unless there is no alternative due to site constraints)
  - i. Sediment pond/berm for sites larger than 5 acres or steeper than 8%. The pond is to be sized to function for 1 inch of rainfall or less.
  - j. BMP installation details.
  - k. Stabilization of tie-slopes and areas that will not be hard-scaped or land-scaped within 14 days, excluding building pads.
  - l. If a project is to be phased, show phasing and applicable BMPs/per phase.
2. Checklist for ESC plans to obtain an ESC Permit for Building Permit approval:
  - a. Items listed in section A above.
  - b. Construction Notes:
    - i. When doing work in the City ROW (E.g. sidewalk, drive pads, utilities, etc...) prevent dirt from getting into the street. If dirt is present in the street, the street should be swept daily or prior to a rain event or contractor induced water event (e.g. curb cut, water test).
    - ii. When installing utilities behind the curb, the excavated dirt should not be placed in the street.
    - iii. When cutting the street for utilities include a note that the dirt shall be placed on the uphill side of the street cut and the area swept after the work is complete. A wattle or mulch sock may be placed at the toe of the excavated dirt pile if site constraints do not allow placing the excavated dirt on the uphill side of the street cut.
3. Checklist for ESC plans to be included in Work Order Construction Plans:
  - a. Items listed in section A, above.
  - b. Plan to show longitudinal street slope and street names.
  - c. On streets where the longitudinal slope is steeper than 2.5%, wattles/mulch socks or j-hood silt fence shall be shown in the front yard swale or on the side of the street.
  - d. Applicable notes from Section B.2, above.

## **Part. 6-15(E) Conceptual Grading and Drainage Plan Submittal Criteria**

Conceptual Grading and drainage plans require less information than presented earlier in this section as they are not for construction and their function is to check the compatibility of the proposed development.

The following criteria are minimum requirements for this type of submittal. Downstream capacity and how determined.

1. Offsite flows should be quantified if they are significant (greater than 5 cfs).
2. Flood zone status- If the site is in a flood zone, the engineer is to provide enough information on how the project will meet the requirements of the National flood Insurance Program and the Flood Hazard Control Ordinance.
3. Existing and proposed topography on and adjacent to the site.
4. Provide developed flows and volumes.
5. Provide stormwater quality volume to be managed.
6. Plans are to be stamped and clearly identified "Preliminary - Not For Construction."
7. If Public drainage infrastructure is required, information must be included to allow the City Engineer to evaluate the infrastructure list.

## **Part. 6-15(F) Engineer's Certification for Non-Subdivisions**

Use this checklist when certifying compliance with an approved drainage report or drainage plan for public, commercial and multi-residential buildings requiring a Certificate of Occupancy building permit or grading and paving projects. Engineer must revise the original drawing as approved with the following information which shall serve as minimum criteria for evaluation. This is merely a guide. The level of detail necessary for presentation and verification is a function of the specific plan being evaluated. The engineer's certification must be approved prior to the release of the issuance of a Certificate of Occupancy, or acceptance (by the City) of the completed work.

1. Completed Information Sheet - see Information Sheet.
2. Provide as-built finished floor and/or pad
3. Provide as-built spot elevations on the property line and/or limits of phase development (points of significant grade changes) to demonstrate compliance with the approved drainage report or drainage plan.
4. Provide written acknowledgement of completed construction from the appropriate government agencies for construction within their right-of-ways and/or easements.
5. Outline the as-built drainage basin(s) (including roof areas) supported with sufficient spot elevations and roof drain locations.
6. Provide as-built elevations and dimensions for the following structures:
  - a. Pond(s) (include as-built volume calculations)
  - b. Pipe inlet(s) and outlet(s) (include as-built capacity calculations)
  - c. Rundown(s) (including the required inlet dimensions)
  - d. Spillway(s) (including the required outlet dimensions)
  - e. Channel(s)

- f. Flowlines
  - g. Erosion control and stormwater pollution prevention structure(s)
  - h. Temporary drainage, erosion control and stormwater pollution prevention facilities required for phased development
  - i. Retaining and/or garden wall(s)
  - j. Other features critical to the drainage scheme.
7. Professional Certification
- a. Engineer's stamp dated and signed accompanied with a statement indicating substantial compliance with the approved drainage report and/or deficiencies with recommended corrections.
  - b. The surveying associated with the certification must be performed by a professional engineer and/or surveyor in accordance with the "New Mexico Engineering and Surveying Practice Act" as amended and any standards adopted by the State Board of Registration.

## **Part. 6-15(G) Engineer's Certification for Subdivisions**

Use this checklist when certifying compliance with an approved drainage report or drainage plan for subdivisions when required by the Development Review Board (DRB) for the release of financial guarantees associated with an executed Subdivision Improvement Agreement (SIA). Engineer must revise the DRB approved drawing with the following information, which shall serve as minimum criteria for evaluation. This is merely a guide. The level of detail necessary for presentation and verification is a function of the specific plan being evaluated. The engineer's certification must be approved prior to the release of the SIA and/or financial guarantees.

1. Completed Information Sheet - see [Information Sheet](#).
2. As-Built Information:
  - a. Pad elevations
  - b. Top of Curb Elevations at critical locations
  - c. Property corner elevations at each lot
  - d. Horizontal and vertical data for storm drains (public and private)
  - e. Horizontal and vertical data for retaining walls
3. As-Built Analysis
  - a. Statement and verification that all grades inside the subdivision do not deviate by more than 18" of the DRB approved grades within 50 feet of the subdivision's perimeter.
  - b. Statement and verification of street, storm drain and channel hydraulic capacities.
  - c. Statement and verification of pond capacities.
  - d. Statement of as-built elevation tolerances with respect to the feature being analyzed.
4. Provide written acknowledgement of completed construction from the appropriate government agencies for construction within their right-of-ways and/or easements.
5. Clearly State the origin and Date(s) of As-Built Data
6. Supplemental Information
  - a. Provide details as necessary to illustrate as-built conditions for instances in which the as-constructed work materially deviates from the as approved design.



- b. Provide calculations to demonstrate and/or verify that all deviations satisfy the intent of the approved design.
- 7. Professional Certification
  - a. Engineer's stamp dated and signed accompanied with a statement indicating substantial compliance with the approved drainage report and/or deficiencies with recommended corrections.
  - b. The surveying associated with the certification must be performed by a professional engineer and/or surveyor in accordance with the "New Mexico Engineering and Surveying Practice Act" as amended and any standards adopted by the State Board of Registration.

## **Part. 6-15(H) Required Certification Language**

The following text shall appear on all Engineer Certifications.

DRAINAGE CERTIFICATION

I, \_\_\_\_\_, NMPE \_\_\_\_, OF THE FIRM \_\_\_\_\_, HEREBY CERTIFY THAT THIS PROJECT HAS BEEN GRADED AND WILL DRAIN IN SUBSTANTIAL COMPLIANCE WITH AND IN ACCORDANCE WITH THE DESIGN INTENT OF THE APPROVED PLAN DATED \_\_\_\_\_. THE RECORD INFORMATION EDITED ONTO THE ORIGINAL DESIGN DOCUMENT HAS BEEN OBTAINED BY \_\_\_\_\_, NMPS \_\_\_\_, OF THE FIRM \_\_\_\_\_. I FURTHER CERTIFY THAT I HAVE PERSONALLY VISITED THE PROJECT SITE ON \_\_\_\_\_ AND HAVE DETERMINED BY VISUAL INSPECTION THAT THE SURVEY DATA PROVIDED IS REPRESENTATIVE OF ACTUAL SITE CONDITIONS AND IS TRUE AND CORRECT TO THE BEST OF MY KNOWLEDGE AND BELIEF. THIS CERTIFICATION IS SUBMITTED IN SUPPORT OF A REQUEST FOR \_\_\_\_\_.

(DESCRIBE ANY EXCEPTIONS AND/OR QUALIFICATIONS HERE IN A SEPARATE PARAGRAPH)

(DESCRIBE ANY DEFICIENCIES AND/OR CORRECTIONS REQUIRED HERE IN A SEPARATE PARAGRAPH)

THE RECORD INFORMATION PRESENTED HEREON IS NOT NECESSARILY COMPLETE AND INTENDED ONLY TO VERIFY SUBSTANTIAL COMPLIANCE OF THE GRADING AND DRAINAGE ASPECTS OF THIS PROJECT. THOSE RELYING ON THIS RECORD DOCUMENT ARE ADVISED TO OBTAIN INDEPENDENT VERIFICATION OF ITS ACCURACY BEFORE USING IT FOR ANY OTHER PURPOSE.

\_\_\_\_\_  
XXXXXXXXXXXXXXXXXXXX, NMPE XXXX  
(SEAL)

\_\_\_\_\_  
DATE

## **ARTICLE 6-16 MAINTENANCE AND POST-CONSTRUCTION RESPONSIBILITY**

All drainage control, flood control and erosion control facilities, both public and private, shall be regularly maintained. Accumulations of silt, trash, litter or stagnant water which create a health or safety hazard or which endanger the design function of the facility are not permitted. Excessive growth or accumulation of woody vegetation in channels and on dams and levees shall not be permitted. Active erosion due to wind or water associated with drainage control, flood control and erosion control facilities shall not be permitted. The City of Albuquerque may conduct inspections to ensure compliance with the City's Drainage Ordinance, Stormwater Quality Ordinance and the EPA MS4 Permit.

### **Part. 6-16(A) Fenced & Gated Public Facilities**

All newly constructed drainage facilities within a public right-of-way must be blocked off at both ends to prevent unauthorized vehicular access with City Standard Tube Gate or removable bollards. Fences must also conform to [Section. 6-8\(G\)\(6\)](#) and [Part. 6-11\(D\)](#). Details must be included on the plans unless a specific City Standard Detail is referenced on the plan.

### **Part. 6-16(B) Drainage Maintenance Plan**

Every Grading and Drainage Plan that involves a privately maintained pond or underground stormwater quality facility must have a Drainage Maintenance Plan on the Grading and Drainage Plan and on the exhibit to the Maintenance Covenant if one is required.

#### **Section. 6-16(B)(1) Purpose**

The purpose of the Maintenance Plan is to ensure all those involved in the maintenance and ongoing operation of the private drainage system understand its functionality and maintenance requirements in terms of supporting long-term performance to the design criteria to which it was designed.

In addition, a Maintenance Plan delivered as part of a drainage submission serves the following additional purposes:

1. Confirms that the designer has taken maintenance into account within the design,
2. Provides a guide to the owner/operator as to what the maintenance requirements of the system are and how they can be met,
3. Provides a basis for estimating long term maintenance budgets,
4. A drainage Covenant will be required for any onsite pond, underground stormwater quality feature or privately maintained drainage facility on public property in accordance with [Article 6-15](#).

The Maintenance Plan for the drainage system should be presented and discussed verbally with all those involved in inspecting and maintaining the drainage system.

### **Section. 6-16(B)(2) Plan Outline**

The Maintenance Plan must include:

- a. Identification of responsible parties.
- b. A description of the access to each surface and sub-surface pond or storm-water quality element for maintenance purposes.
- c. A description of the method of safe and sustainable removal and disposal of waste periodically arising from the drainage system.
- d. The maintenance schedule of work - itemizing the tasks to be undertaken and the frequency at which they should be performed so that acceptable long-term performance is achieved
- e. The method of monitoring sediment accumulation, including specific reference to a permanent marker installed in the pond to be used for such measurements.
- f. If infiltration is used to justify a reduction in pond volume then provisions for inspection and maintenance must be specified in order to insure the design infiltration rate is achieved. If the rate is not achieved then the pond volume should be increased to that required without any reduction for infiltration. The volume that the pond has been reduced by infiltration must be stated on the plan so that the pond size can be easily increased if the design infiltration rate is not achieved. The plan should include procedures for checking and documenting the infiltration rate on a regular basis to insure that the accumulation of fine particles in the bottom of the pond does not decrease the infiltration rate to less than the required design rate. The rate must be specified in the maintenance plan, for example, 20" of standing water should infiltrate in 24 hours or less. It should also include provisions for corrective actions such as removing accumulated fine particles from the pond to restore the designed infiltration rate.

## **Part. 6-16(C) Drainage Maintenance Covenants**

### **Section. 6-16(C)(1) Applicability**

Nearly all new developments include drainage improvements that are required by [The Code of Ordinances, Chapter 14 - Zoning, Planning and Building, Article 5-Flood Hazard and Drainage Control](#), with the possible exception of a site that is allowed free discharge and for which stormwater quality requirements are waved. In those instances where such drainage features must be perpetually maintained to minimize possible damage to other properties or to public properties, the City may require the property owner to enter into a covenant or provide a note on the plat assuring maintenance of such facilities.

### **Section. 6-16(C)(2) Procedures for Covenants**

The Hydrology Section of the Planning Department maintains fillable forms available for download for three (3) types of covenants which are discussed below. Covenants run with the land. They generally require the owner of the

land to maintain features to City standards and allow the City's entrance upon the property to inspect drainage features for such maintenance as needed, so the covenant must and be signed by the actual owner of the land with a notary confirmation of the owner's identity.

The blanks on the fillable forms must be filled in and exhibits of the approved facilities must be prepared by a responsible representative of the owner. The signed and notarized original document must be submitted to the Design Review Section of the Planning Department along with a check for the recording fees and a copy of the deed as proof of ownership. City staff will then review the covenant and record the document in the Bernalillo County Records, then e-mail a recorded copy to the applicant.

When the drainage facility is located onsite, Covenants must be recorded prior to Certificate of Occupancy for new commercial Building Permits, and prior to approval of the Grading and/or Paving Permit for commercial projects that do not include a Building Permit. When the facility is located offsite, the Covenant must be recorded prior to approval of any permits, and prior to recording any plats, and prior to issuance of work order for all types of development for which Hydrology Section approval is required. The following is a brief description of the three types of drainage covenants the City may require the developer to provide:

- 1. Private Facility Drainage Covenant** is for a privately owned, privately maintained facility. It places maintenance and inspection responsibility on the property owner(s). For example, a scour protection wall to protect property adjacent to an unlined arroyo or a first flush pond.
- 2. Drainage Covenant (no public easement)** - for a privately owned, privately maintained facility whose non-function or failure to perform, will cause damage to others. For example, a large detention pond in a shopping center. The maintenance responsibilities lie with the owner. The City, however, has the right to inspect periodically and to enforce proper maintenance.
- 3. Agreement and Covenant** - for a privately maintained facility which is within the City's property (City right-of-way or City easement). The City has the right to inspect and to enforce proper maintenance. If the City right-of-way or City Easement does not already exist before the development then one must be dedicated and/or granted in accordance with the "Final Plat" or "Grant of Drainage Easement" Procedures above. For example, an Agreement and Covenant may be required for phased developments that require temporary retention ponds and/or sediment ponds.

### **Section. 6-16(C)(3) Procedures for Plats**

The Hydrology Section of the Planning Department maintains standard language to be placed on plats with provisions for private maintenance of drainage facilities in drainage easements that is available for download. The language must be included on both preliminary and final plats prior to approval by Hydrology, and must be used in lieu of a separate Covenant to identify maintenance responsibilities for onsite facilities wherever possible.

## ARTICLE 6-17 COMMON EQUATIONS

The most commonly used equations in drainage submittals are: weir, orifice and Manning's. They are presented below.

### Part. 6-17(A) Weirs

A weir is a barrier in an open channel, over which water flows. A weir with a sharp upstream corner or edge such that the water springs clear of the crest is a "sharp crested weir". All other weirs are classified as "weirs not sharp crested". Weirs are to be evaluated using the following equation:

$$\text{EQUATION 7.62 } Q = CLH^{3/2}$$

**where:**

**Q** = Discharge in cfs

**C** = Discharge coefficient use 2.7. If a discharge coefficient other than 2.7 is to be used, provide justification in drainage submittal.

**L** = Effective length of crest in feet

**H** = Depth of flow above elevation of crest in feet (approach velocity shall be disregarded in most applications)

Weirs are generally used as measuring and hydraulic control devices. Emergency spillways in which critical depth occurs and overflow-type roadway crossings of channels are the most common applications of weirs. Channel drop structures and certain storm drain inlets may also be analyzed as weirs. Special care must be exercised when selecting weir coefficients in the following cases:

1. Submerged weirs
2. Broad crested weirs
3. Weirs with obstructions (i.e., guardrails, piers, etc.)

### Part. 6-17(B) Orifices

An orifice is a submerged opening with a closed perimeter through which water flows. Orifices are analyzed using the following equation:

$$\text{EQUATION 7.63 } Q = CA (2gh)^{1/2}$$

**when:**

**Q** = Discharge in cfs

**C** = Discharge coefficient use 0.6. If a discharge coefficient other than 0.6 is to be used, provide justification in the drainage submittal.

**A** = Area of opening in square feet

**g** = 32.2 ft/sec<sup>2</sup>

**h** = Depth of water measured from the center of the opening

Approach velocity shall be disregarded in most applications.

Orifices are generally used as measuring and hydraulic control devices. Orifice hydraulics control the function of many "submerged inlet - free outlet" culverts,

primary spillways in detention facilities, manholes in conduit flow, and in storm drain catch basins.

## Part. 6-17(C) Manning’s Equation and Coefficient

Manning’s equation is used to calculate flow, due to gravity, in open channels and conduits. In a conduit, the HGL must be below the soffit. As the Manning’s Roughness Coefficient value increases the velocity decreases and the HGL increases. The equation is presented below:

$$EQUATION 7.64 \quad Q = (1.486AR^{2/3}S^{0.5})/n$$

**where:**

**Q** - Flow Rate in Cubic Feet per Second

**A** - Flow Area

**R** - Hydraulic Radius;  $R=A/P$  where A is the flow area and P is the wetted (flow) perimeter

**S** - Slope

**n** - Manning’s Roughness Coefficient (values to be used in drainage submittals shown below)

**TABLE 6.17.20 Values of Manning’s “n”**

Material	n
Plastic Pipe-Smooth Bore	0.010
Reinforced Concrete Pipe	0.013
Poured Concrete	0.013
No-Joint Cast In Place Concrete Pipe	0.014
Reinforced Concrete Box	0.015
Reinforced Concrete Arch	0.015
Streets	0.017
Flush Grouted Rip-Rap	0.020
Corrugated Metal Pipe	0.025
Grass Lined Channels (Sodded & Irrigated)	0.025
Earth Lined Channels (Smooth)	0.030
Arroyo Channels	0.030
Wire Tied Rip-Rap	0.040
Medium Weight Dumped Riprap	0.045
Grouted Rip-Rap (Exposed Rock)	0.045
Arroyo Overbank	0.045
Jetty Type Rip-Rap ( $D_{50} > 24"$ )	0.050

## ARTICLE 6-18 HISTORY

In August of 2015, two technical subcommittees were convened to update this chapter. One subcommittee was convened to evaluate a new hydrologic model, evaluate hydraulic models and revise the closed conduit and open channel sections of this chapter. The current hydrologic model, AHYMO, was not replaced as the subcommittee decided that further study was required.

Members of this subcommittee are listed below:

**Curtis Cherne, PE, CFM**

Technical Subcommittee Chair

City of Albuquerque

**Daniel Aguirre** Wilson and Company

**Rick Beltramo** Galway Construction

**Alandren Etlantus** Bohannon Huston Incorporated

**Andreas Sanchez** SSAFCA

**Gerhard Schoener** SSAFCA

**Stephen Scissons** Army Corp of Engineers

**Brad Bingham** AMAFCA

**Shahab Biazar** City Engineer

**Brian Patterson** Titan Development

**Rita Harmon** City of Albuquerque

**Charles Easterling** Easterling and Associates

**Kevin Daggett** City of Albuquerque

**Dave Thompson** Thompson Engineering Associates

**Don Briggs** Bernalillo County

**Hugh Floyd** RESPEC

**Pat Stovall** Smith Engineering

**Vince Carrica** Tierra West

The second subcommittee convened to evaluate all other sections of the chapter. The chapter was reorganized for easier use and was structured with the approach to help the development community with site development. Some of the larger changes are:

1. Addition of Floodplain Development
2. Addition of Valley Drainage Criteria
3. Emphasis on Downstream Capacity and Offsite Flows
4. Incorporation of erosion control specifications for pipes outletting into ponds and arroyos from "Urban Storm Drainage Criteria Manual Volume 2" from the Urban Drainage and Flood Control District, Denver, Colorado, June 2001, revised April 2008.
5. Addition of Low Impact Development
6. Removal of Probable Maximum Flood/Precipitation and Dam Design

Members of this subcommittee are listed below:

**Curtis Cherne, PE, CFM**

Technical Subcommittee Chair

City of Albuquerque



<b>Don Briggs</b>	Bernalillo County
<b>Abiel Carrillo</b>	City of Albuquerque
<b>Kevin Daggett</b>	City of Albuquerque
<b>Scott Steffen</b>	Bohannon Huston Incorporated
<b>Ron Hensley</b>	The Group
<b>Diane Hoelzer</b>	Mark Goodwin and Associates
<b>Jeff Mortensen</b>	High Mesa Consulting Group
<b>Graeme Means</b>	High Mesa Consulting Group
<b>Brian Patterson</b>	Titan Development
<b>Kevin Patton</b>	Pulte Homes
<b>David Soule</b>	Rio Grande Engineering
<b>Jeff Wooten</b>	Wooten Engineering
<b>Rita Harmon</b>	City of Albuquerque

The DPM Technical Subcommittee would like to dedicate this revision to Jeff Mortensen P.E., who sadly passed away during the revising of this manual. Jeff was very knowledgeable in all aspects of drainage and he was involved with the creation of Chapter 22 and every revision since its inception.

February 2015, the DPM revision was approved to incorporate requirements from the EPA MS4 Permit for post-construction development and infiltration was acknowledged in the design of ponds.

Section 22.2, Hydrology was first published in March, 1982, as one of the sections in the three-volume Development Process Manual (DPM). The DPM is the result of the effort of a special team of City of Albuquerque staff and Albuquerque Urban Advisory Council members. The Manual was created in response to mutual needs of the private and public sectors in Albuquerque to clarify the development process. The Three volumes of the DPM are: 1 - "Procedures", 2 - "Design Criteria". The Third Volume "Policies and Plans" is obsolete.

A major revision to Section 22.2 was adopted with the approval of a "Notice of Emergency Rule" by the City in January, 1986. This revision deleted a procedure which based rational method "C" coefficients on SCS Hydrologic Soil Group, and adopted Rational Method Coefficients based on textbook and handbook references.

The "D.P.M. Subcommittee on Drainage" was established by the City of Albuquerque in January, 1987. The Subcommittee held its first meeting in February, 1987. The Subcommittee consisted of members from City staff, Albuquerque Metropolitan Arroyo Flood Control Authority (AMAFCA) staff and local engineering consultants, and was organized to update and revise the DPM design criteria for Section 22.2, Hydrology. The Bernalillo County Public Works Department later joined the Subcommittee. In January, 1990 the subcommittee changed its name to the DPM "Drainage Design Criteria Committee" to avoid potential confusion with another committee established by the DPM Steering Group.

The Drainage Design Criteria Committee has met on a regular basis to develop a major update of the hydrology section of the DPM. In 1987, a research study to determine local infiltration factors was conducted by Dr. Richard Heggen at the University of New Mexico to supplement the work of the Committee.

A “draft” of the “Revision of Section 22.2, DPM” was distributed for community review in January, 1990. This document recommended use of initial abstraction and uniform infiltration to complete rainfall loss. It also included a procedure for smaller basins based on the Rational Method, and a procedure for large and small watersheds based on the HYMO computer program.

With the adoption of the Bernalillo County Storm Drainage Ordinance (No. 90-6) the County Engineer was responsible for establishing criteria, procedures and standards for the design of flood control, drainage controls, and erosion control improvements. To fulfill this requirement, Bernalillo County adopted “Interim Drainage Design Criteria for Bernalillo County” (April, 1990). This document incorporated Parts A, B, E and F from the January, 1990 draft of Section 22.2, Hydrology.

In January, 1991, a revision of “Section, 22.2,” was distributed to eight (8) Federal and State agencies, and to 26 local engineering firms. A public “Notice of Review” was published in the Albuquerque Journal and Tribune on February 4, 1991. Following incorporation of review comments, the August, 1991 version of Section 22.2, Hydrology was released for use by the Drainage Design Criteria Committee. This version included the placement of the rainfall peak in this second hour of the design storm. Modifications to the Probable Maximum Flood procedures incorporated a “local storm” and a “general storm.” A “Notice of Second Review” was published in the Albuquerque Journal and Tribune on August 31, 1991. The August, 1991 version has been accepted by the City, County and AMAFCA as an allowable procedure for hydrologic analysis and design of flood control structures.

The January, 1993 version of Section 22.2, Hydrology incorporates comments received since August, 1991. The version includes a procedure to evaluate basin hydrology for steep natural slopes, and some text revisions suggested by the USDA Soil Conservation Service. For most applications, there will be no computational differences between the January, 1993 version and the August, 1991 version. The text has been reformatted into seven (7) separately numbered parts to simplify future revision of the document.

The pages which follow replaced all previous pages in the Hydrology Section of the DPM (Section 22.2, pages 2 through 21). Following a public review and comment period, the revised Section 22.2, Hydrology was approved by the City Engineer and the Mayor. In the City of Albuquerque, the revision became effective on April 7, 1993. Bernalillo County also adopted the revision as the standard for design of flood and drainage control, effective April 7, 1993. The revised Section 22.2, Hydrology is to be regarded as the principal reference for hydrologic design in the City of Albuquerque and Bernalillo County.

The Drainage Design Criteria Committee wish to acknowledge the assistance of the many individuals who reviewed the document. In particular we wish to thank Richard Leonard, Brian Burnett and Dwayne Sheppard for their work on the Committee.

The D.P.M. Drainage Design Criteria Committee:

**Richard J. Heggen, PE, PH, PhD**  
Professor of Civil Engineering  
University of New Mexico

**Howard C Stone, PE**

Water Resources Manager  
Bohannon-Huston Inc.

**Clifford E. Anderson, PE & PS**

Drainage Engineer, AMAFCA

**Charles M. Easterling, PE**

Pres., Easterling & Assoc.

**Robert S. Foglesong, PE & PS**

Surface Water Hydrologist  
Bernalillo County Public Works

**Fred Aguirre, PE**

Hydrologist, PWD  
City of Albuquerque

## ARTICLE 6-19 REFERENCE

The reference section remains unchanged, as the latest revision used committee members' experience. Their years of experience were a valuable resource. Their names are listed in the History section.

### Part. 6-19(A) Hydraulics

#### Section. 6-19(A)(1) Weirs and Orifices

1. King and Brater: Handbook of Hydraulics, McGraw Hill Book Company, Inc., New York, Fifth Edition 1963
2. Merritt: Standard Handbook for Civil Engineers, McGraw Hill Book Company, Inc., New York, 1968
3. Streeter: Fluid Mechanics, McGraw Hill Book Company, Inc., New York, Fifth Edition

#### Section. 6-19(A)(2) Closed Conduits

1. Los Angeles County Flood Control District Design Manual - Hydraulic, P.O. Box 2418 Los Angeles, California 90054 Rev. 1973.

#### Section. 6-19(A)(3) Channels

1. Chow: Open Channel Hydraulics, McGraw Hill Book Company, Inc., New York, 1959
2. U.S. Army Corps of Engineers:- Hydraulic Design of Flood Control Channels EM 1110-2-1601,. Office of the Chief of Engineers, Washington, D.C. 20314, 1970
3. Merritt: Standard Handbook for Civil Engineers, McGraw Hill Book Company, Inc., New York, 1968.
4. Morris and Wiggert: Applied Hydraulics in Engineering, the Ronald Press Company Second Edition, 1972
5. U.S. Department of the Interior, Bureau of Reclamation: Hydraulic Design of Stilling Basins and Energy Dissipaters, U.S. Government Printing Office, Washington, Fourth Printing, Revised 1973
6. U.S.D.A Soil Conservation Service: Planning and Design of Open Channels, Technical Release No. 25, Washington, D.C., October, 1971
7. U.S.D.A Soil Conservation Service:. Sedimentation, National Engineering Handbook, Section 3, Chapter 4, Washington, D.C., 1971
8. Simons, Li and Associates: Design Guidelines and Criteria - Channels and Hydraulic Structures on Sandy Soil, P.O. Box 1816 Ft. Collins, Colorado, 80522, 1981
9. Los Angeles County Flood Control Authority, Design Manual Hydraulic P.O. Box 2418 Los Angeles, California 90054 Rev. 1973.
10. Albuquerque Metropolitan Arroyo Flood Control Authority Draft Design guide for Trapezoidal Concrete Flood Control Channels, Rev. April, 1982.

#### Section. 6-19(A)(4) Catch Basins

1. Los Angeles County Flood Control Authority, Design Manual - Hydraulic P.O. Box 2418 Los Angeles, California 90054 Rev. 1972.

*Section. 6-19(A)(5)* **Street Hydraulics**

1. See Reference Section. 6-18(A)(3) 1
2. See Reference Section. 6-18(A)(3) 4

*Section. 6-19(A)(6)* **Berms and Levees**

1. See Reference Section. 6-18(A)(3) 6
2. See Reference Section. 6-18(A)(3) 7
3. See Reference Section. 6-18(A)(3) 8

# CHAPTER 7

## TRANSPORTATION DESIGN

This chapter presents criteria for the design of street systems and related features to accommodate differing needs. These criteria are intended to assure acceptable levels of comfort, safety, quality and durability in completed designs.

### ARTICLE 7-1 CONTENTS

#### ARTICLE 7-1 INTRODUCTION .....316

#### ARTICLE 7-2 PURPOSE AND SCOPE .....316

Part. 7-2(A) Governing Regulations .....	317
Section. 7-2(A)(1) Albuquerque/Bernalillo County Comprehensive Plan.....	317
Section. 7-2(A)(2) Integrated Development Ordinance (Article 14-16 ROA 1994)	317
Section. 7-2(A)(3) Drainage Ordinance (Part 14-5-2 ROA 1994) .....	317
Section. 7-2(A)(4) Street Tree Ordinance (Article 6-6 ROA 1994).....	317
Section. 7-2(A)(5) Traffic Code (Chapter 8 ROA 1994).....	318
Section. 7-2(A)(6) Streets and Sidewalk Ordinance (Chapter 6-5 ROA 1994) ..	318
Section. 7-2(A)(7) Long Range Transportation System Guide (LRTS) .....	318
Section. 7-2(A)(8) Bikeway & Trails Facility Plan .....	318
Section. 7-2(A)(9) Corridor Studies.....	318
Section. 7-2(A)(10) Reference List and Other Applicable Design Manuals and	
Resources .....	319
Part. 7-2(B) Using the DPM to Determine Roadway Specifications .....	320
Section. 7-2(B)(1) Roadway Evaluation Process.....	320
Section. 7-2(B)(2) Standards versus Guidelines .....	321
Section. 7-2(B)(3) Design Variance.....	321
Section. 7-2(B)(4) Roadway Evaluation.....	321
Section. 7-2(B)(5) Other Design Considerations.....	322
Part. 7-2(C) Street Elements.....	323
Section. 7-2(C)(1) Pedestrian Realm.....	323
Section. 7-2(C)(2) Travel Way.....	324
Section. 7-2(C)(3) Design Speed.....	326
Section. 7-2(C)(4) Street Element Table.....	327

#### ARTICLE 7-3 ROADWAY DESIGN CONTEXT.....329

Part. 7-3(A) Transportation Planning and Policy .....	329
Part. 7-3(B) Regional Transportation Planning.....	330
Section. 7-3(B)(1) Metropolitan Transportation Plan .....	330
Section. 7-3(B)(2) Long Range Transportation Systems Guide.....	332
Section. 7-3(B)(3) Functional Classification .....	334
Section. 7-3(B)(4) Right of Way Ranges.....	337
Part. 7-3(C) City of Albuquerque-Bernalillo County Comprehensive Plan ..	338
Section. 7-3(C)(1) General Purpose .....	338

Section. 7-3(C)(2) Implications for the DPM.....339  
 Section. 7-3(C)(3) Comp Plan Corridors.....339  
 Section. 7-3(C)(4) Comp Plan Centers .....341  
 Section. 7-3(C)(5) Policy Matrices.....343  
 Section. 7-3(C)(6) Other Considerations.....344  
 Part. 7-3(D) City of Albuquerque Complete Streets Ordinance ..... 345  
     Section. 7-3(D)(1) Definition of Complete Streets.....345  
     Section. 7-3(D)(2) Purpose of Ordinance.....345  
     Section. 7-3(D)(3) Street Design and Implementation.....345  
     Section. 7-3(D)(4) Connection between the Complete Streets Ordinance and the  
         DPM.....346  
 Part. 7-3(E) Principles of Network Design and Roadway Connectivity..... 346  
     Section. 7-3(E)(1) Connectivity .....346  
     Section. 7-3(E)(2) Regional Connectivity and Spacing of Major Roads.....347  
     Section. 7-3(E)(3) Neighborhood Connectivity.....348  
     Section. 7-3(E)(4) Intersection Density.....348  
     Section. 7-3(E)(5) Regional Network Considerations.....349

**ARTICLE 7-4 DESIGN STANDARDS..... 350**

Part. 7-4(A) Network Connectivity..... 350  
     Section. 7-4(A)(1) Purpose of Section.....350  
     Section. 7-4(A)(2) Definition of terms.....350  
     Section. 7-4(A)(3) Connectivity.....352  
     Section. 7-4(A)(4) General Network Considerations.....354  
     Section. 7-4(A)(5) Block Lengths.....355  
     Section. 7-4(A)(6) Traffic Signal Spacing.....355  
     Section. 7-4(A)(7) Designated Pedestrian Crossings.....357  
 Part. 7-4(B) Site Access Points..... 361  
     Section. 7-4(B)(1) Definitions.....361  
     Section. 7-4(B)(2) General Guidance and Curb Cut Ordinance.....361  
     Section. 7-4(B)(3) Pedestrian Access.....362  
     Section. 7-4(B)(4) Vehicular Access.....362  
     Section. 7-4(B)(5) Curb Return Design .....365  
     Section. 7-4(B)(6) Access Control.....367  
     Section. 7-4(B)(7) Striping and Signage.....368  
     Section. 7-4(B)(8) Roadways in NMDOT Jurisdiction.....368  
 Part. 7-4(C) Pavement Design..... 368  
     Section. 7-4(C)(1) General Provisions.....368  
     Section. 7-4(C)(2) Subgrade Materials Evaluation.....368  
     Section. 7-4(C)(3) Traffic Factors in Pavement Design.....371  
     Section. 7-4(C)(4) Structural Design of Pavement.....373  
     Section. 7-4(C)(5) Flexible Pavements Design .....375  
     Section. 7-4(C)(6) Portland Cement Concrete Design.....377  
     Section. 7-4(C)(7) Alternative Pavement .....377  
 Part. 7-4(D) Curb and Gutter ..... 378  
     Section. 7-4(D)(1) Public Right of Way Requirements.....378  
     Section. 7-4(D)(2) Private Property Requirements.....378  
 Part. 7-4(E) Pedestrian Facilities..... 378  
     Section. 7-4(E)(1) Public Sidewalks.....379  
     Section. 7-4(E)(2) Pedestrian Walkways.....389  
 Part. 7-4(F) Bikeways and Trails ..... 390  
     Section. 7-4(F)(1) General Provisions .....390  
     Section. 7-4(F)(2) Locations of Future Facilities.....391  
     Section. 7-4(F)(3) Bicycle Lanes .....391



Section. 7-4(F)(4) Bicycle Routes .....	393
Section. 7-4(F)(5) Bicycle Boulevards .....	393
Section. 7-4(F)(6) Paved Trails .....	394
Section. 7-4(F)(7) Trail Alternatives .....	396
Part. 7-4(G) Public Transit .....	396
Section. 7-4(G)(1) General Provisions .....	396
Section. 7-4(G)(2) Pedestrian Connections to Transit Stops .....	397
Section. 7-4(G)(3) Boarding and Alighting Areas .....	397
Section. 7-4(G)(4) Transit Stop Types .....	399
Section. 7-4(G)(5) Roadway Design Considerations for Transit in Mixed Flow Traffic 401	
Section. 7-4(G)(6) Dedicated Transit Infrastructure .....	404
Part. 7-4(H) On-Street Parking .....	405
Section. 7-4(H)(1) General Provisions .....	405
Section. 7-4(H)(2) Design Guidance .....	406
Section. 7-4(H)(3) Maintenance and Parking Agreements .....	409
Section. 7-4(H)(4) Creation of New On-Street Parking During Site Development 410	
Section. 7-4(H)(5) Parklets .....	410
Part. 7-4(I) Geometric Design Criteria .....	412
Section. 7-4(I)(1) General Design Criteria .....	413
Section. 7-4(I)(2) Horizontal Alignment .....	413
Section. 7-4(I)(3) Superelevation .....	413
Section. 7-4(I)(4) Vertical Alignment .....	414
Section. 7-4(I)(5) Sight Distance .....	415
Section. 7-4(I)(6) Intersection Design .....	419
Section. 7-4(I)(7) Median and Turn Lane Design .....	424
Part. 7-4(J) Local Streets .....	432
Section. 7-4(J)(1) Local Street Classifications .....	432
Section. 7-4(J)(2) Local Street Design .....	434
Section. 7-4(J)(3) Stub, Cul-de-Sac, and Loop Street Criteria .....	436
Section. 7-4(J)(4) Emergency Service Access to Local Streets .....	437
Section. 7-4(J)(5) Private Streets .....	438
Section. 7-4(J)(6) Private Ways .....	438
Section. 7-4(J)(7) Entrance and Gate Requirements for Private Ways and Streets 439	
Part. 7-4(K) Off-Street Parking and Site Design .....	439
Section. 7-4(K)(1) General Provisions .....	439
Section. 7-4(K)(2) Bicycle Parking .....	440
Section. 7-4(K)(3) Motorcycle Parking .....	441
Section. 7-4(K)(4) Standard and Small Car Parking .....	441
Section. 7-4(K)(5) ADA Accessible Parking .....	442
Section. 7-4(K)(6) Angled Parking .....	443
Section. 7-4(K)(7) Pavement of Parking Areas .....	444
Section. 7-4(K)(8) Curbing in Parking Areas .....	445
Section. 7-4(K)(9) Grading in Parking Areas .....	445
Section. 7-4(K)(10) Sidewalk Connections .....	445
Section. 7-4(K)(11) Site Access .....	445
Section. 7-4(K)(12) Fire and Emergency Access .....	446
Section. 7-4(K)(13) Solid Waste Access .....	446
Section. 7-4(K)(14) Access Throat Length and Queuing .....	446
Section. 7-4(K)(15) Site Layout and Circulation .....	447
Section. 7-4(K)(16) Parking Islands .....	447
Section. 7-4(K)(17) Service Areas .....	448

Section. 7-4(K)(18) Signage & Striping.....448  
 Section. 7-4(K)(19) Drive-Through Facilities .....448  
 Section. 7-4(K)(20) Layout of Large Parking Areas .....449  
 Section. 7-4(K)(21) Traffic Circulation Layout Requirements .....449  
 Part. 7-4(L) Traffic Calming..... 449  
     Section. 7-4(L)(1) Neighborhood Traffic Calming .....449  
     Section. 7-4(L)(2) Speed Management on Major Roads.....449  
 Part. 7-4(M) Street Lighting..... 451  
     Section. 7-4(M)(1) Roadway Lighting Criteria.....451  
     Section. 7-4(M)(2) New Lighting System Considerations.....453  
     Section. 7-4(M)(3) Distribution Criteria.....453  
     Section. 7-4(M)(4) Correlated Color Temperature (CCT) .....453  
     Section. 7-4(M)(5) Luminaire Criteria.....454  
     Section. 7-4(M)(6) Street Lighting Development Build out Requirements .....455  
 Part. 7-4(N) Traffic Control and Development Requirements..... 456  
     Section. 7-4(N)(1) Traffic Control & Phasing Plan.....456  
     Section. 7-4(N)(2) Traffic Construction and Fees.....456  
 Part. 7-4(O) Naming of Streets ..... 457  
     Section. 7-4(O)(1) Markings.....458  
     Section. 7-4(O)(2) Signage .....458  
     Section. 7-4(O)(3) Traffic Signals.....459  
     Section. 7-4(O)(4) Barricades at Ends of Pavements Signage .....459

**ARTICLE 7-5 TRAFFIC STUDIES..... 460**

Part. 7-5(A) Background and Purpose..... 460  
 Part. 7-5(B) Traffic Scoping Form and Traffic Impact Study ..... 461  
     Section. 7-5(B)(1) Traffic Scoping Form.....461  
     Section. 7-5(B)(2) Traffic Impact Study.....461  
 Part. 7-5(C) Traffic Study Warranting Criteria..... 462  
     Section. 7-5(C)(1) Traffic Scoping Form Warranting Criteria.....463  
     Section. 7-5(C)(2) Traffic Impact Study Warranting Criteria.....464  
 Part. 7-5(D) Traffic Analysis Procedures..... 464  
     Section. 7-5(D)(1) Traffic Scoping Forms .....464  
     Section. 7-5(D)(2) Traffic Impact Studies .....465  
 Part. 7-5(E) TIS Report Elements ..... 466  
     Section. 7-5(E)(1) Executive Summary .....466  
     Section. 7-5(E)(2) Introduction .....466  
     Section. 7-5(E)(3) 4.5.3 Existing Conditions.....467  
     Section. 7-5(E)(4) Future Traffic Conditions and Analysis Years .....469  
     Section. 7-5(E)(5) Proposed Site Traffic Characteristics .....470  
     Section. 7-5(E)(6) Traffic Analysis.....471  
     Section. 7-5(E)(7) Site Access Requirements.....473  
     Section. 7-5(E)(8) Summary of Findings .....473  
     Section. 7-5(E)(9) Recommendations and Mitigation Measures.....473  
     Section. 7-5(E)(10) Appendix.....475  
 Part. 7-5(F) NIA- Neighborhood Impact Assessment..... 475  
     Section. 7-5(F)(1) NIA Purpose/Scope.....475  
     Section. 7-5(F)(2) NIA Minimum Requirements.....475

**ARTICLE 7-6 DEFINITIONS ..... 476**

## ARTICLE 7-2 INTRODUCTION

Transportation in an urban environment is a complex interaction of different modes of travel, trip purposes, and land use contexts. This chapter presents criteria established for use in the design of street systems and related features to accommodate these differing needs. These criteria are intended to ensure acceptable levels of comfort, safety, quality, and durability in completed transportation projects.

The guidance and regulations provided in the transportation chapter of the Development Process Manual (DPM) are intended for use by qualified design professionals familiar with municipal street design. A brief overview of important governing regulations is presented together with references to commonly-accepted design manuals and publications related to the subject. Designers and others using this manual are expected to familiarize themselves fully with the pertinent regulations and the publications cited in the DPM.

The infrastructure standards contained in the DPM are intended to provide public benefits and support the health, welfare, and safety of Albuquerque residents. While the use of minimum design standards typically results in the lowest cost for a project, the use of above minimum design may result in a more effective design with operational benefits and a more economic life cycle cost. The design values in this chapter represent the minimum standard; however, the project designer is encouraged to use values above this minimum.

## ARTICLE 7-3 PURPOSE AND SCOPE

The transportation chapter of the DPM establishes standards and guidance both for private developers during the creation of site development and master plans, and the City of Albuquerque for the design of new roadways or reconstruction and rehabilitation of existing roadways. The purpose of this chapter is to promote consistently sound design of street systems with acceptable performance characteristics, to encourage innovative design, and to assert the need for sound, responsible, professional judgment by the designer.

Standards and guidelines established by this document rely on best practices from national design manuals and standards utilized by similar sized municipalities. This chapter was also developed in coordination with the [Albuquerque-Bernalillo County Comprehensive Plan](#) (Comp Plan) and the [Integrated Development Ordinance](#) (IDO) to ensure that land use and transportation strategies work together within the City of Albuquerque. The linkages between applicable policy and regulatory documents that inform infrastructure standards contained in the transportation chapter are further described in [Article 7-4 Roadway Design Context](#). This chapter also provides step-by-step guidance in the roadway design process to help designers correctly apply DPM standards when designing facilities within the City.

## Part. 7-3(A) Governing Regulations

Following are overviews of important City policy and regulatory documents pertaining to street design. The list is not intended to be exhaustive, and the user is cautioned that these regulations are subject to change at any time. The 2018 update to the DPM ensures that street design standards are consistent with the following ordinances and regulations. Nevertheless, competent designers must maintain familiarity with these and other pertinent regulations as they are updated over time.

### Section. 7-3(A)(1) Albuquerque/Bernalillo County Comprehensive Plan

*The Albuquerque/Bernalillo County Comprehensive Plan* contains a shared community vision for how the City of Albuquerque and Bernalillo County should grow and confront long-term challenges as well as the cultural and environmental features that should be protected in the future. As a policy document, the Comp Plan contains guidance about where growth is appropriate and what form it should take, including Center and Corridor designations and policy matrices. See the Roadway Design Context section for additional information on the relationship between the Comp Plan and the DPM.

### Section. 7-3(A)(2) Integrated Development Ordinance (Article 14-16 ROA 1994)

The *Integrated Development Ordinance* contains regulations relating to access, circulation, and parking on private property; the interface with public right-of-way; and maximum block length and size. The IDO establishes zoning and land use categories which, in turn, govern certain street design parameters.

The Subdivision chapter of the Integrated Development Ordinance includes the following topics which are particularly relevant to street design:

- *Requirements for Traffic Engineer approval of any plat that creates public right-of-way and private access easements.*
- *General right-of-way standards for streets, based upon roadway classification.*
- *Requirements for the provision of and compliance with detailed design criteria and technical standards for construction in the DPM.*

### Section. 7-3(A)(3) Drainage Ordinance (Part 14-5-2 ROA 1994)

The *Drainage Ordinance* establishes requirements governing design of storm runoff facilities as such facilities relate to the street system. The Drainage Ordinance also requires at least one all-weather access to developments.

### Section. 7-3(A)(4) Street Tree Ordinance (Article 6-6 ROA 1994)

The *Street Tree Ordinance* requires the installation of trees along major streets when obtaining building permits or paving parking lots.

### Section. 7-3(A)(5) Traffic Code (Chapter 8 ROA 1994)

The [Traffic Code](#) regulates general traffic control, enforcement of construction signing, and establishes the criteria for clear-sight geometry at intersections.

### Section. 7-3(A)(6) Streets and Sidewalk Ordinance (Chapter 6-5 ROA 1994)

The [Streets and Sidewalk Ordinance](#) contains the following guidance and requirements:

- **Street Names:** Establishes consistent criteria for use in naming City streets and streets within the extraterritorial planning and platting jurisdiction of the City.
- **Future Street Lines:** Provides for establishment of future street lines by the City Council. The Ordinance prohibits the construction of buildings and substantial alterations and additions to existing structures within such designated future street lines and setback areas.
- **Sidewalks:** Establishes the requirement for the construction of sidewalk and curb and gutter for properties, including dimensional, location, and construction regulations for sidewalks.
- **Curb Cuts:** Regulates the location, dimensions, and placement of driveway entrances through curbs to public rights-of-way.
- **Complete Streets:** Provides direction to the City to evaluate all design projects and incorporate all modes of transportation when designing or rehabilitating streets. See the Roadway Design Context section for additional information.

### Section. 7-3(A)(7) Long Range Transportation System Guide (LRTS)

The [Long Range Transportation Systems Guide](#) contains maps depicting the long-range transportation networks through the Albuquerque urban area, as adopted by the Metropolitan Transportation Board (MTB). See [Article 7-4 Roadway Design Context](#) for additional information.

4. Long Range Roadway System
5. The Long Range Roadway System guides the locations and right-of-way set-aside for major streets.
6. Long Range Bikeway System
7. The Long Range Bikeway System depicts the current and future bikeway systems for the region.

### Section. 7-3(A)(8) Bikeway & Trails Facility Plan

The [Bikeways & Trails Facility Plan](#) (BTFP) provides direction for the City of Albuquerque in development of a well-connected, enjoyable, and safe bicycle and trail network. Many of the design guidelines and standards from the BTFP are incorporated into this chapter.

### Section. 7-3(A)(9) Corridor Studies

Corridor studies take place regularly throughout the City, and such studies may influence design of major streets. The City's [Transportation Division](#) of the Department of Municipal Development should be consulted for detailed information.

## Section. 7-3(A)(10) Reference List and Other Applicable Design Manuals and Resources

### 7-3(A)(10)(i) [Roadway Design](#)

1. AASHTO, *A Policy on Geometric Design of Highways and Streets*, 2011 or latest edition
2. *Geometric Design Criteria*
3. AASHTO, *Roadside Design Guide*, 4th edition, 2011, or latest edition
4. Transportation Research Board, *Highway Capacity Manual (HCM)*, 2010 or latest edition
5. Federal Highway Administration (FHWA), *Manual on Uniform Traffic Control Devices (MUTCD)*, 2009 version or latest edition
6. Institute for Transportation Engineers (ITE), *Designing Walkable Urban Thoroughfares*, 2010 version or latest edition
7. National Association of City Transportation Officials (NACTO), *Urban Street Design Guide*, 2016 version or latest edition
8. GREEN BOOK?

### 7-3(A)(10)(ii) [Pavement Design](#)

1. American Association of State Highway and Transportation Officials (AASHTO), *Guide for Design of Pavement Structures, 1993*
2. AASHTO, *Guide for Design of Pavement Structures, Part II*, Rigid Pavement Design and Rigid Pavement, American Association of State Highway and Transportation Officials, 1998 Supplement
3. City of Albuquerque, *Standard Details*, Section 2400

### 7-3(A)(10)(iii) [Pedestrian Facilities](#)

1. U.S. Access Board, *Americans with Disabilities Act Accessibility Guidelines (ADA)*, 2004 edition
2. U.S. Access Board, *Public Rights of Way Accessibility Guide (PROWAG)*, 2013 version.
3. U.S. Access Board, *Americans with Disabilities Act Final Guidelines for Outdoor Developed Areas*, 2013
4. City of Albuquerque, Integrated Development Ordinance (IDO) Section 14-16-5-6(C), *General Landscaping Standards*, 2017
5. City of Albuquerque, IDO, *Street Frontage Landscaping* 14-16-5-6(D)
6. City of Albuquerque, *Street Tree Ordinance* (6-6-2), 2015 or latest revision
7. City of Albuquerque, DPM, Chapter 22, *Low Impact Development (LID)*, 2017 or latest revision

### 7-3(A)(10)(iv) [Bikeways and Trails](#)

1. AASHTO, *Guide for the Development of Bicycle Facilities*, 4th Edition, 2012 version or latest edition
2. NACTO, *Urban Bikeway Design Guide*, Second Edition, or latest edition
3. Federal Highway Administration (FHWA), *Manual on Uniform Traffic Control Devices (MUTCD)*, 2009 version or latest edition
4. City of Albuquerque, City of Albuquerque *Bikeways & Trails Facility Plan (BTFFP)*, 2015 or latest version
5. Mid Region Council of Governments (MRCOG), *Transportation Plan's Long Range Bikeway System (LRBS)*

6. [\*Americans with Disabilities Act Accessibility Guidelines \(ADA\)\*](#), latest edition

### 7-3(A)(10)(v) [Public Transit](#)

1. U.S. Access Board, [\*Americans with Disabilities Act Accessibility Guidelines \(ADA\)\*](#), 2004 edition
2. U.S. Access Board, [\*Public Rights of Way Accessibility Guide \(PROWAG\)\*](#), 2013 version.
3. NACTO, [\*Transit Street Design Guide\*](#), 2016 version
4. AASHTO, [\*Guide for the Geometric Design of Transit Facilities on Highways and Streets\*](#), 2014 version
5. American Public Transportation Association, [\*Designing Bus Rapid Transit Running Ways\*](#), 2010 version
6. TCRP Report 90, [\*Bus Rapid Transit Volume 2: Implementation Guidelines\*](#), 2003

### 7-3(A)(10)(vi) [Off-Street Parking](#)

1. Federal Highway Administration (FHWA), [\*Manual on Uniform Traffic Control Devices \(MUTCD\)\*](#), 2009 version or latest edition
2. City of Albuquerque, [\*Motorcycle parking ordinance\*](#) (O-16-28)
3. City of Albuquerque [\*Traffic Code\*](#)
4. City of San Francisco, [\*San Francisco Parklet Manual\*](#), 2015

### 7-3(A)(10)(vii) [Traffic Calming](#)

1. City of Albuquerque, [\*Neighborhood Traffic Management Program \(NTMP\)\*](#), 2015 or latest edition

## **Part. 7-3(B) Using the DPM to Determine Roadway Specifications**

### **Section. 7-3(B)(1) Roadway Evaluation Process**

Designers should follow a series of steps to determine the appropriate range in right-of-way and street design standards when considering the design of a new roadway or rehabilitation or reconstruction of an existing facility. [TABLE 7.3.21](#) below and the DPM User Guide assist designers and users through the roadway evaluation process to ensure relevant policies and design standards are considered.

Roadway design guidance in the DPM is generally based on three types of considerations:

1. **Comp Plan Corridor** – City-specific designations reflecting the intended urban design and priority modes and street elements for major roadways.
2. **Functional Classification** – designations defined by the Federal Highway Administration regarding the role of the roadway in moving people and goods.
3. **Design Speed** – the actual speed motorists are intended to travel under free-flow traffic conditions. Design speed is a function of roadway geometry. Some technical and geometric standards for roadways vary depending on the design speed rather than the roadway type. General guidance on



design speeds are provided by Comp Plan Corridor type and functional classification in the Street Elements Table. See [Part. 7-3\(C\) Street Elements](#).

Additional information on functional classification and Comp Plan Corridor designations are provided in the Roadway Design Process section.

### Section. 7-3(B)(2) Standards versus Guidelines

The DPM contains a combination of requirements and recommendations for transportation infrastructure. In instances where the term “shall” is utilized, the design information constitutes a standard where implementation is mandatory. If the term “should” is used, the design information constitutes a guideline and designers are encouraged to apply the guidelines to the greatest extent feasible.

### Section. 7-3(B)(3) Design Variance

Where deviations from the DPM are necessary due to topographical, right-of-way, or other constraints, a design variance may be requested from the City Engineer. The variance process is described in [Chapter 2 Development Procedures](#).

### Section. 7-3(B)(4) Roadway Evaluation

[TABLE 7.3.21](#) outlines the process a designer should follow when designing a roadway and choosing necessary roadway elements and suitable dimensions. Standards for desired roadway elements are contained throughout the transportation chapter of the DPM.

<b>TABLE 7.3.21 Roadway Evaluation Process</b>	
<b>Step</b>	<b>Actions Required by Roadway Designer</b>
<b>1. Consult the Long Range Roadway System</b>	<p>Determine functional classification and right-of-way ranges.</p> <p>If the roadway is classified as a principal arterial, determine whether the corridor is a regional principal arterial or a community principal arterial on the Long Range Roadway System (right-of-way needs vary depending on the regional role of the principal arterial).</p> <p>Identify existing right-of-way.</p>
<b>2. Consult the Comprehensive Plan Center and Corridors Network map</b>	<p>Determine relevant <u>land use designation</u>, including whether the corridor passes through transit station areas or identified Comp Plan Centers that have special guidance.</p> <p>Identify the <u>Corridor type</u>. The Corridor designation provides guidance on priorities by travel mode and other design characteristics.</p> <p>Check for references to the roadway on the Long Range Bicycle System, Bikeways and Facilities Trails Plan, MTP Priority Transit Network, and MTP Primary Freight Network.</p>

**TABLE 7.3.21 Roadway Evaluation Process**

Step	Actions Required by Roadway Designer
<b>3. Review the Priority Street Elements Matrix</b>	Determine which modes of transportation and street design elements should be prioritized, depending on the Corridor type and Center designations.
<b>4. Review Existing Conditions</b>	Analysis should determine if changes to the configuration of the roadway are desired. Considerations include: roadway configuration, travel conditions, traffic volume, alternative mode infrastructure and transit service, landscaping and sidewalk width, and medians and turn lanes.
<b>5. Design / Redesign</b>	Complete roadway design to support intended roadway users and surrounding land use context. This may vary along the roadway corridor.

**Section. 7-3(B)(5) Other Design Considerations**

1. ADA/PROWAG
  - a. All new streets shall be constructed in compliance with ADA/PROWAG standards. During reconstruction projects, designers shall make every effort to ensure the street is brought into compliance with ADA/PROWAG. Where PROWAG standards conflict with ADA standards, the ADA standards shall prevail.
2. Design Vehicle
  - a. The design vehicle to be utilized in the roadway design and redesign process shall be an SU-30. Where high levels of heavy truck travel are anticipated, an alternative design vehicle may be utilized with approval by the City Engineer. See the [Section. 7-5\(I\)\(6\)](#) and [Part. 7-5\(B\) Site Access Points](#) for guidance on curb return radii and other design elements where consideration of the design vehicle is required.
3. Level of Service
  - a. Auto Level of Service
    - i. The Comp Plan establishes appropriate level of service (LOS) by location. Per the Comp Plan, auto mobility needs are to be balanced against the needs of other roadway users. Lower levels of service and somewhat higher levels of congestion are acceptable where non-auto travel modes are prioritized, such as along Premium Transit and Main Street Corridors. The acceptable LOS also varies as roadways pass through designated Centers where there are high levels of pedestrian activity. [TABLE 7.3.22](#) contains auto LOS by Center and Corridor type or functional classification.

**TABLE 7.3.22 Auto Level of Service by Corridor and Location**

Functional Classification & Roadway Type	Transit Station Area	Downtown	Urban Center	Activity Center (mixed-use)	Village Center	Employment Center	Outside Activity Center
Premium Transit	E-F	E-F	E-F	E-F	E-F	E-F	E-F

TABLE 7.3.22 Auto Level of Service by Corridor and Location

Functional Classification & Roadway Type	Transit Station Area	Downtown	Urban Center	Activity Center (mixed-use)	Village Center	Employment Center	Outside Activity Center
Major Transit	E	E-F	E	E	D-E	D-E	D-E
Maint Street	E	E	E	E	D-E	D-E	D-E
Commuter	E	E	D-E	D-E	D-E	D-E	D
Other Arterial	E	E	E	D-E	D-E	D-E	D
Minor Arterial	E	E	D-E	D-E	D-E	D	D
Collector	E	D-E	D	D	C-D	C-D	C-D
Main Street	E	E	E	E	E	E	E

**NOTE:** From City of Albuquerque Comprehensive Plan, 2017

4. Multi-modal Level of Service
  - a. Multi-modal LOS analysis is encouraged as part of the roadway redesign process to identify locations where pedestrian and bicycle infrastructure could be improved. The DPM does not require that a certain multi-modal LOS be obtained or that a particular multi-modal LOS tool be utilized. However, design principles that support higher multi-modal LOS are integrated throughout the DPM and the City of Albuquerque design standards.
5. NMDOT Facilities
  - a. NMDOT-owned facilities are not governed by the standards or guidelines contained in the DPM. Coordination with NMDOT is required and standards from the NMDOT Design Manual shall be utilized where a City-led project is undertaken on an NMDOT-owned facility.

## Part. 7-3(C) Street Elements

Modest differences in design ensure that roadways support the surrounding land use context. Therefore, the design of streets in the City of Albuquerque varies depending on the Corridor type and location. This section defines major street elements and provides general guidance on the principles that govern the design and redesign of roadways.

**NOTE:** Right-of-way set-aside is also based on functional class. The right-of-way set-aside does not dictate that the road be designed to meet the dedicated width; the footprint of a roadway may be as narrow as appropriate to meet travel needs.

The street elements are divided into two sections:

1. **Travel Way**, which includes the curb-to-curb area utilized for vehicle and bicycle travel;
2. **Pedestrian Realm**, which includes the landscaping area and pedestrian access route (i.e., sidewalk).

### Section. 7-3(C)(1) Pedestrian Realm

The Pedestrian Realm is the generally elevated area above the Travel Way between the curb and the right-of-way line or the property line of the adjacent

parcel. The Pedestrian Realm elements include the frontage zone, sidewalk, and the landscape/buffer zone.

The scale and design of Pedestrian Realm elements vary depending on the Corridor type and location. In general, wider buffers and sidewalks are desired in areas with high levels of pedestrian activity, including designated Centers and along certain designated Corridors. Detailed guidance can be found in the Pedestrian Facilities section, including the application of the standards listed in [TABLE 7.3.23](#) during reconstruction projects.

### **7-3(C)(1)(i) [Frontage Zone](#)**

The frontage zone constitutes the segment between the sidewalk and the property line, which may be located within the public right-of-way. The presence of frontage zones reduces the likelihood of encroachments, conflicts between vehicular and pedestrian traffic, and of walls or other vertical structures being erected in the clear sight triangle. Frontage zones are most appropriate on roadways classified as collectors or above, and on non-residential local streets. The frontage zone is typically between 1'-2.5' on all roadways classified as collectors and above. See the Local Streets section for additional guidance.

### **7-3(C)(1)(ii) [Sidewalks](#)**

A hard-surfaced walk or raised path and any curb ramps or blended transitions along and generally paralleling the side of the streets for pedestrians. Sidewalks do not include the curb and gutter. For ADA/PROWAG purposes, the sidewalk area is also referred to as the "pedestrian access route," and must be free of obstacles, protruding objects, and vertical obstructions.

### **7-3(C)(1)(iii) [Landscape/Buffer Zone](#)**

The landscape/buffer zone, also referred to as the furnishing zone, constitutes the area between the curb and the sidewalk and provides space for signage, utilities, storm water catchment, landscaping, street furnishings, and driveway aprons. The landscape/buffer zone separates the sidewalk from automobile traffic, and allows for the necessary space at crossings to install ADA/PROWAG accessible ramps at intersections. The top of the curb is included in the landscape/buffer zone, but is not considered part of the sidewalk.

## **Section. 7-3(C)(2) Travel Way**

The Travel Way may include curb and gutter, shoulders, bicycle facilities, transit amenities, on-street parking, travel lanes, medians, and turn lanes. Design guidance within the Travel Way generally depends on the Comp Plan Corridor designation, and whether a roadway segment is located inside or outside of a Comp Plan-designated Center. If roadways have no Comp Plan Corridor designation, guidance is provided by functional classification.

### **7-3(C)(2)(i) [Curb and Gutter](#)**

Curb and Gutter constitute the area along the edge of a street that separates the elements in the Pedestrian Realm from the Travel Way and serves an important role in stormwater management. See [Part. 7-5\(D\) Curb and Gutter](#) for gen-

eral requirements and dimensions. See [Chapter 6](#) for additional considerations, including low-impact development.

The gutter pan is considered as part of the overall roadway width; it may be counted as part of the width of the curbside travel lane or on-street parking space. The gutter pan is not included as part of the width of a bicycle lane.

### **7-3(C)(2)(ii) [Shoulders](#)**

Shoulders are the space between the outside of the driving lane and the curb or roadway edge, and generally serve as a buffer, to provide space for disabled vehicles on high-speed roadways, and to provide space for maintenance and emergency vehicles.

Bicycle lanes may take the place of a shoulder, although buffers between the bicycle lane and the curb may also serve as shoulder space. In rural areas without curb and gutter, the shoulder may be unpaved. The width of the shoulder depends on the location and the available right-of-way.

### **7-3(C)(2)(iii) [Bicycle Facilities](#)**

Bicycle facilities include on-street bicycle lanes, separated multi-use paths, and buffers that provide additional comfort and safety for cyclists. See [Part. 7-5\(F\) Bikeways and Trails](#) for standards related to bicycle facilities, as well as guidance on the appropriate locations for bicycle facilities.

### **7-3(C)(2)(iv) [Transit Amenities](#)**

Dedicated or transit-specific infrastructure may be utilized within the Travel Way depending on the context, and are more appropriate for some corridor types than others. Transit stop amenities are generally located in the Pedestrian Realm. See [Part. 7-5\(G\) Public Transit](#) for further guidance.

### **7-3(C)(2)(v) [On-street Parking](#)**

On-street parking constitutes dedicated areas generally on the edge of the Travel Way and adjacent to the curb for vehicles to park. On-street parking may be parallel or angled, depending on the available right-of-way and the location. See [Part. 7-5\(H\) On-Street Parking](#) for guidance on appropriate locations and dimensions.

### **7-3(C)(2)(vi) [Travel Lanes](#)**

Travel lanes are dedicated areas for vehicle traffic. The design of general purpose travel lanes should be consistent with the intended role of the facility, including the types of vehicle and the needs of all potential users, as well as the surrounding land use context. Bicycle lanes are considered to be travel lanes.

The widths provided in [TABLE 7.3.23](#) are consistent with national standards. Narrow lanes (i.e. the low end of the ranges in [TABLE 7.3.23](#)) can result in lower speeds and reduced crossing distances and are encouraged in locations where a balance of modes is desired, high-speed vehicle travel is less critical, and in areas with high levels of pedestrian activity. Travel lanes narrower than those in-

icated in [TABLE 7.3.23](#) may be considered under highly constrained conditions and require the approval of the City Engineer.

See [Article 7-5 Design Standards](#) for additional guidance on roadway network design principles. See [Part. 7-5\(G\) Public Transit](#) for guidance related to dedicated transit infrastructure and travel lanes where transit operates in mixed flow traffic.

The width of the travel lane is measured from the center of lane striping and the curb face. The gutter pan may be included as part of the width of curbside travel lanes.

### **7-3(C)(2)(vii) [Medians](#)**

Medians are the center portion of the roadway that separates general purpose travel lanes moving in opposite directions. Medians frequently incorporate features to provide safety benefits and improve operations by providing space for turning vehicles. Some form of raised or striped median is desirable on principal and minor arterials, with wider medians required along segments with turn lanes or turn bays.

Center turn lanes may be incorporated as part of a median and interspersed with landscaped median islands. Medians may also serve as pedestrian or bicycle refuges, whether as raised features or through pylons, pavement markings, and signage that distinguish the pedestrian safe zone. See [Section. 7-5\(I\)\(7\)](#) for additional guidance.

### **7-3(C)(2)(viii) [Turn Lanes](#)**

Turn lanes provide dedicated space for vehicles to complete a turning movement without blocking the flow of traffic. They may be continuous in the center of a roadway, combined with medians, or located at intersections. Intersection turn lanes may be on the inside or outside of the road, depending on the turning movement direction. Turn lane width varies depending on the Corridor type, the type of turn lane, and the design speed. See [Section. 7-5\(I\)\(7\)](#) for more information on various design options.

## **Section. 7-3(C)(3) Design Speed**

The design speed by Corridor type and location, as identified in the Comp Plan, is provided in [TABLE 7.3.23](#). The design speed is a function of roadway geometry and reflects the actual speed motorists are intended to travel under free-flow traffic conditions. Standards for the various geometric elements that affect design speed are located throughout the transportation chapter.

The design speeds provided in [TABLE 7.3.23](#) reflect a general approach that slower speeds are more appropriate in locations with high levels of bicycle and pedestrian travel, such as Centers and along certain designated Corridors, as well as collectors and local streets. Higher design speeds are appropriate outside of designated Centers and along roadways where vehicle throughput is most critical. Posted speeds are established only after appropriate examination of the completed street by the Traffic Engineer.

### **Section. 7-3(C)(4) Street Element Table**

[TABLE 7.3.23](#) summarizes design standards for various street elements by location. The table does not indicate whether the street elements are required for a particular roadway and should be used in combination with the Priority Street Element Matrix of the Comp Plan, which provides guidance on roadway elements that should be included on Comp Plan-designated Corridors. For example, sidewalks are required on all roadways in the City of Albuquerque, while the presence of bicycle infrastructure depends on the location and available right-of-way. [TABLE 7.3.23](#) indicates the standard widths when street elements are included.

Achieving standards widths for desired elements may be particularly challenging for roadway reconstruction projects, thus requiring some level of prioritization on individual roadways and consideration of the roles that a series of roads play across the network. For reconstruction projects, the landscape/buffer zone should be provided as space allows.



FIGURE 7.3.41 Street Element Dimensions Along Major Roads

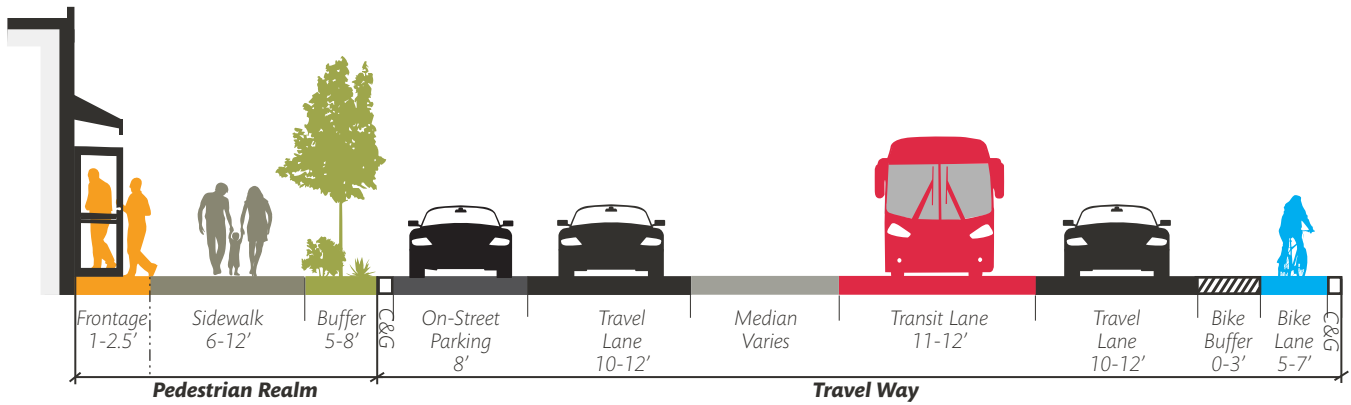


TABLE 7.3.23 Street Element Dimensions

Corridor Type	Location	Design Speed (MPH)	Pedestrian Realm			Travel Way		
			Frontage Zone	Sidewalk Width	Landscape / Buffer Zone	Bike Lane Width*	Bike Buffer	Travel Lane Width**
Premium Transit	Inside Center	30-35	1-2.5'	10-12'	6-8'	6-6.5'	0-3'	10-12'
	Outside Center	35-40	1-2.5'	8-10'	6-8'	6-7'	1.5-3'	10-12'
Major Transit	Inside Center	30-35	1-2.5'	10-12'	6-8'	5-6.5'	0-3'	10-12'
	Outside Center	35-40	N/A	6-10'	6-8'	6-7'	1.5-3'	10-12'
Multi- Modal	Inside Center	30-35	1-2.5'	10-12'	6-8'	5-6.5'	0-3'	10-11'
	Outside Center	35-40	N/A	6-10'	6-8'	6-7'	1.5-3'	10-11'
Commuter	Inside Center	30-35	1-2.5'	10'	6-8'	5-6.5'	1.5-3'	10-12'
	Outside Center	40-50	N/A	6'	6-8'	6-7'	3-5'	10-12'
Main Street	Main Street	25-30	1-2.5'	10-12'	6-8'	5-6.5'	0-3'	10-11'
Other Arterial	Inside Center	30-35	1-2.5'	10'	6-8'	5-6.5'	0-3'	10-11'
	Outside Center	35-40	N/A	6'	5-6'	6-7'	1.5-3'	10-11'
Minor Arterial	Inside Center	30-35	1-2.5'	10'	6-8'	5-6.5'	0-3'	10-11'
	Outside Center	35-40	N/A	6'	5-6'	6-6.5'	1.5-3'	10-11'
Major Collector	Inside Center	25-30	1-2.5'	10'	5-6'	5'	0-3'	10-11'
	Outside Center	30-35	N/A	6'	5-6'	5-6'	0-3'	10-11'
Minor Collector	Inside Center	25-30	1-2.5'	10'	5-6'	5'	0-3'	10-11'
	Outside Center	30-35	N/A	6'	5-6'	5-6'	0-3'	10-11'
Major Local	Inside / Outside Center	18-30	1-2.5' / N/A	5'	5-6'	Shared Lane**		See Local Road Section
Other Locals	Inside / Outside Center	15-25	1-2.5' / N/A	5'	4-6'	N/A	N/A	

\*Not including the gutter pan.

\*\* Dedicated bicycle infrastructure may be appropriate along some Major Local Streets. In these circumstances, use the design characteristics of a minor collector (inside center). See [Part 7-5\(J\) Local Streets](#) for more information.

## ARTICLE 7-4 ROADWAY DESIGN CONTEXT

Planning efforts in the Albuquerque area emphasize the connection between land use and transportation and creating streets that are appropriate for the surrounding context. To support a range of policy and planning objectives, the design standards and guidance contained in the transportation chapter of the DPM are linked to the location of the roadway and the surrounding land use context.

This section clarifies the relationship among

- Long-range regional planning efforts
- City of Albuquerque policies
- Detailed design standards contained in the transportation chapter of the DPM

Designers are encouraged to refer to this section to understand the sources of DPM design standards and the rationale behind design priorities.

### Part. 7-4(A) Transportation Planning and Policy

The DPM represents the most specific planning and design document for the City of Albuquerque and connects the general policies and recommendations of planning documents related to land use and transportation to the actual design and function of City streets. In practice, this document translates the policies and vision to location-specific design standards. The Roadway Design Context section describes these key planning documents and how each planning effort builds upon the layer that preceded it (see [FIGURE 7.4.42](#) and [TABLE 7.4.24](#)).

FIGURE 7.4.42 Transportation and Land Use Planning



The highest level regional planning takes place through the **Metropolitan Transportation Plan (MTP)** and is performed by the Mid-Regional Metropolitan Planning Organization (MRMPO) with the participation of member agencies, including the City of Albuquerque and Bernalillo County. The MTP examines where growth will take place, identifies strategies for meeting future transportation needs, and provides a list of all anticipated transportation

projects in the 20-plus year timeframe of the plan. The scope of the MTP has broadened over time as MRMPO began undertaking scenario planning efforts to understand different ways the region could grow and the resulting impacts on the transportation system. Although the MTP is a regionally-approved document, it relies on local jurisdictions for policy implementation and project development. The most recent MTP includes the **Long Range Transportation Systems (LRTS) Guide**), which provides right-of-way ranges and general design guidance based on the roadway type and the surrounding land use context.

The *Albuquerque-Bernalillo County Comprehensive Plan (Comp Plan)* provides a vision for how growth should occur specifically in the City of Albuquerque and in unincorporated portions of Bernalillo County. The plan emphasizes additional development in designated Centers and Corridors and describes the desired characteristics of these locations. The Comp Plan provides greater detail on Corridor types than the LRTS Guide or MTP, including policy guidance on the form and function of different facilities.

The *Integrated Development Ordinance (IDO)* synthesizes policies and recommendations into guidance on land uses, density, and other characteristics of the built environment, as well as infrastructure requirements for new subdivisions. The IDO is the primary land use implementation tool of the Comp Plan. However, for the policies of the Comp Plan and the regulations of the IDO to be effective in creating places that support multi-modal transportation, they must be complemented by street design standards, such as those contained in the DPM.

<b>TABLE 7.4.24 Planning Document and Relevance for DPM</b>		
<b>Planning Effort</b>	<b>Level</b>	<b>Scope / Relevance</b>
<b>Metropolitan Transportation Plan</b>	Regional	Policy document and long-term project list
<b>Long Range Transportation Systems Guide</b>	Regional	Regional role of corridors; right-of-way ranges
<b>Comprehensive Plan</b>	City / County	Policy document
<b>Integrated Development Ordinance</b>	City	Zoning code and subdivision ordinance
<b>Development Process Manual</b>	Site / Roadway	Street design and site development guidance

## **Part. 7-4(B) Regional Transportation Planning**

### **Section. 7-4(B)(1) Metropolitan Transportation Plan**

#### **7-4(B)(1)(i) General Purpose**

The Metropolitan Transportation Plan (MTP), updated every five years, examines the transportation challenges facing the Albuquerque Metropolitan

Planning Area (AMPA) over the next 20-25 years. The reference document at the time of the adoption of the Comp Plan and the update to the DPM is the Futures 2040 MTP.

The MTP is a product of MRMPO, a regional government planning agency responsible for long-range transportation planning and for the programming of near-term federal transportation dollars in the AMPA. MRMPO is housed within the Mid-Region Council of Governments (MRCOG) and works closely with member agencies, such as the City of Albuquerque, Bernalillo County, and other transportation partners and stakeholders to develop the MTP. The MTP sets priorities for how federal transportation dollars available to the region through the Transportation Improvement Program will be allocated. The plan is also the source of the region's household and employment projections and forecasts how population and employment growth is distributed within the metropolitan area.

The role of MRMPO and the MTP is to identify long-term regional transportation needs and strategies to address those needs, and to incentivize agencies to pursue programs and projects that have the greatest regional benefits. MRMPO is overseen and the MTP must be adopted by the Metropolitan Transportation Board, comprised of elected officials and other representatives from agencies and jurisdictions across the region, including the City of Albuquerque.

#### **7-4(B)(1)(ii)** [Scenario Planning](#)

In addition to a Trend Scenario, the regionally-adopted socioeconomic forecast that projects future development patterns based on existing plans and policies, the 2040 MTP contains a Preferred Scenario, developed collaboratively with agencies from across the AMPA, which demonstrates that encouraging growth in activity centers and along transit corridors has a range of benefits. These include reduced total driving or vehicle miles traveled (VMT), lower levels of congestion due to more efficient use of the transportation network, improved access to services and employment sites, lower transportation-related CO emissions, and a smaller development footprint that reduces the amount of new housing and employment sites at risk due to the impacts of climate change.

#### **7-4(B)(1)(iii)** [Relationship between the MTP and City of Albuquerque Planning Documents](#)

The MTP establishes the general connection between transportation infrastructure and surrounding land use and provides the regional framework under which more specific planning and roadway design efforts take place. The 2040 MTP and the Preferred Scenario are reflected in goals of the Comp Plan that support increased transportation options and higher density and a mix of land uses in targeted locations. The MTP and the Comp Plan share an emphasis on additional development within activity centers and corridors, and designations from the MTP Priority Transit Network are included in the Comp Plan as Premium Transit or Major Transit Corridors. See [Section 7-4\(C\)\(2\)](#) for additional discussion on Comp Plan Corridor designations.

The MTP and the Comp Plan further also share policies and strategies for reducing VMT and managing congestion, including travel demand manage-

ment strategies that increase transportation choice by supporting investments in alternative modes of transportation and reduce the number of peak-period single-occupancy vehicle trips. Implementing MTP-related goals, particularly those related to alternative modes, requires streetscapes that support travel options for all users. The DPM specifically supports City and regional planning objectives through roadway design standards.

## **Section. 7-4(B)(2) Long Range Transportation Systems Guide**

### **7-4(B)(2)(i) [General Purpose](#)**

The LRTS Guide was developed as part of the update to the 2040 MTP and translates Plan recommendations and Complete Streets principles into general street design guidelines. Objectives of the LRTS Guide include supporting regional travel requirements, balancing the needs of all modes, and ensuring street designs are compatible with the built environment. The LRTS Guide replaces the Future Albuquerque Area Bikeways and Streets (FAABS) document, which guided new roadway construction for decades.

### **7-4(B)(2)(ii) [Applications of the LRTS Guide in the DPM](#)**

Though the design guidance in the LRTS Guide is largely superseded for the City of Albuquerque by the standards contained in the DPM, there are several components of the LRTS Guide that apply to roadway design within the City of Albuquerque (See [TABLE 7.4.25](#)). Critical components of the LRTS Guide include:

- *Long-range system maps*
- *Right-of-way requirements for new arterials and collectors*
- *Guidance related to overall network design and connectivity*

**TABLE 7.4.25 Applications of the LRTS Guide in the DPM**

<b>LRTS Guide Component</b>	<b>DPM Integration / Implications</b>	<b>Action Required by Designer</b>
<b>1. Long-range system maps</b>	The system maps identify future roadways and bicycle facilities that must be incorporated into subdivision layout and roadway design.	Refer to Long Range Roadway System and Long Range Bicycle System Map for location of current and future facilities.
<b>2. Right-of-way guidance</b>	The LRTS Guide is the source for right-of-way requirements for all roads classified as collectors or above. Right-of-way requirements for principal arterials vary depending on whether the corridor is designated as a regional or a community principal arterial.	Refer to table <a href="#">TABLE 7.3.23</a> on right-of-way ranges

**TABLE 7.4.25 Applications of the LRTS Guide in the DPM**

<b>3. Network connectivity standards</b>	The DPM provides standards related to block length, traffic signal space, and pedestrian crossing frequency, among other considerations.	Consult <a href="#">Article 7-5 Design Standards</a> for standards related to block length and the spacing of major roads. Additional guidance related to intersection density and network design for large subdivisions can be found in <a href="#">Part 7-5(A) on page 350</a> and the LRTS Guide.
--	--	--

**7-4(B)(2)(iii) [Long Range System Maps](#)**

The Long Range Roadway System (LRRS) is the regional network consisting of all existing and proposed arterial and collector roadways. Facilities may be included in the LRRS regardless of whether funding is currently identified. (Only roads with identified funding are included in the MTP.)

The Long Range Bikeway System (LRBS) contains all existing and proposed bikeway and trail facilities. The LRBS consolidates local bicycle planning efforts completed by jurisdictions across the region.

**7-4(B)(2)(iv) [LRTS Guide and LRRS Roadway Types](#)**

The LRTS Guide provides right-of-way ranges for new roadways by functional classification (see [Section 7-4\(B\)\(3\)](#) for discussion of functional classification and [Section 7-4\(B\)\(4\)](#) for additional information on right-of-way ranges). To ensure that the right-of-way required for new principal arterials supports the surrounding context, the LRRS designates regional and community principal arterials, reflecting the fact that roadways with the same functional classification may serve different purposes. Per the LRTS Guide, different levels of right-of-way should be set-aside depending on the designation as a regional or a community principal arterial. These designations also inform the role and function of the roadway, including whether vehicle throughput is prioritized to improve regional mobility, or whether the infrastructure should support a range of modes and access to local land uses (See [TABLE 7.4.26](#)).

**TABLE 7.4.26 LRRS Roadway Types**

<b>LRRS Roadway Type</b>	<b>Purpose of Designation</b>	<b>Examples</b>
<b>Regional Principal Arterial</b>	Identify facilities where higher speed vehicle travel should be preserved and where access management strategies could be pursued.	Paseo del Norte, Tramway Blvd, Rio Bravo Blvd

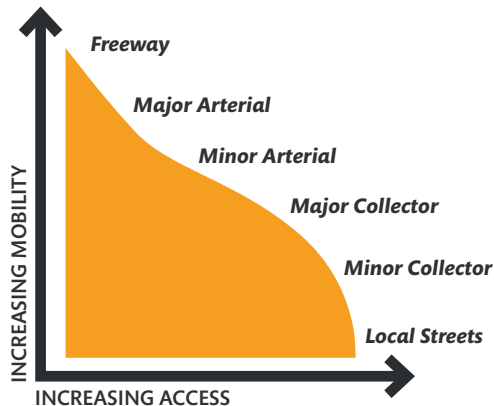
<b>LRRS Roadway Type</b>	<b>Purpose of Designation</b>	<b>Examples</b>
<b>Community Principal Arterial</b>	Ensure that a particular mode is not to be prioritized at the expense of others, and that the corridor is meant to bring people to an area as opposed to through the area (as is the case with regional principal arterials).	Central Ave, Irving Blvd, San Mateo Blvd

### Section. 7-4(B)(3) Functional Classification

#### 7-4(B)(3)(i) [General Purpose and Background](#)

Functional classification is used to identify the role of a roadway in moving people and goods, determine eligibility to receive federal funding, and for system monitoring and prioritizing resource allocation. Many jurisdictions also use functional classification in determining maintenance schedules and operational improvements, such as investments in Intelligent Transportation Systems.

**FIGURE 7.4.43 Access and Functional Class**



A number of factors determine the functional classification of a roadway, including:

- Mileage (the uninterrupted length of the road)
- Traffic volume, including the volume of a facility relative to other routes
- Posted speed and/or observed travel speeds;
- Travel lanes and roadway capacity;
- Existing land use and future development;
- Spacing between routes.

The purposes of a roadway are particularly important in determining functional classification, including whether a facility is meant to serve longer-distance travel needs (i.e. mobility) or provide access to local land uses. Roads that provide more entrance and exit points and serve shorter distance trips are generally



classified as local roads or as collectors, while roads that serve longer-distance trips and connect larger destinations are generally arterial roads. [TABLE 7.4.27](#) defines the typical roadway features by functional classification.

Functional classification within the City of Albuquerque and Bernalillo County were updated in 2015 and are maintained by the New Mexico Department of Transportation. All proposed changes to functional classifications must be proposed and approved through MRMPO before final approval by the NMDOT.

**7-4(B)(3)(ii) [Functional Classification and the DPM](#)**

While national design manuals are generally organized around functional classification, the DPM provides detailed roadway design guidance for arterial roadways based on Comp Plan Corridor designations, where applicable. For collectors and arterials where no Comp Plan Corridor designation is applied, guidance and standards are applied by functional classification or design speed. The DPM also provides standards for local streets that provide direct land access and connections to the higher order streets. Additional guidance is provided where roadways pass through designated Centers. Within a major subdivision, City staff may assign a Comp Plan Corridor designation for new roadways during the master plan review process.

<b>TABLE 7.4.27 Roadway Functional Classification Descriptions (source: FHWA and LRTS Guide)</b>			
	<b>Description</b>	<b>Design Considerations</b>	<b>Bicycle Infrastructure Options</b>
<b>Functional Classification : Principal Arterial</b>	<ul style="list-style-type: none"> <li>- Generally high traffic-volume corridors serving long-distance trips</li> <li>- Serve major destinations and centers and provide critical connections across and within a region</li> <li>- Provide a high degree of mobility for motorists but low levels of land access</li> </ul>	<ul style="list-style-type: none"> <li>- Generally two or three through lanes per direction with a central left turn lane.</li> <li>- Regular transit service is common and premium transit with dedicated lanes may be appropriate.</li> <li>- On-street parking may be considered only in activity centers or urban areas with commercial activity</li> <li>- Due to high speeds and traffic volumes, bikeways should not be included on these roadways if there are existing parallel routes within 1,000 feet</li> <li>- Narrower lanes can be considered in activity centers and locations with high levels of pedestrian activity</li> </ul>	<ul style="list-style-type: none"> <li>- Barrier protected bicycle lane/cycle track within activity centers</li> <li>- Bicycle lane with striped buffer</li> <li>- Parallel roadways within 1,000' in areas with a grid network</li> <li>- Adjacent multi-use paths</li> </ul>

**TABLE 7.4.27 Roadway Functional Classification Descriptions (source: FHWA and LRTS Guide)**

	<b>Description</b>	<b>Design Considerations</b>	<b>Bicycle Infrastructure Options</b>
<b>Functional Classification : Minor Arterial</b>	<ul style="list-style-type: none"> <li>- • Serve trips of moderate length</li> <li>- Connect to and complement principal arterials, provide intra-community connectivity</li> <li>- May carry local bus routes</li> <li>- Provide more land access than principal arterials without penetrating individual neighborhoods.</li> <li>- Generally have fewer lanes, lower speed limits, and lower traffic volumes (6,000-20,000 ADT) than principal arterials</li> </ul>	<ul style="list-style-type: none"> <li>- Generally, two through lanes per direction with a central left turn lane. Transit service is common in mixed-flow on general purpose lanes.</li> <li>- On-street parking may be considered in activity centers or urban areas with commercial activity</li> <li>- Number of lanes should support current or near-term term project traffic volume; excessive capacity should be avoided.</li> <li>- Narrower lanes may be considered in activity centers with high pedestrian volumes</li> </ul>	<ul style="list-style-type: none"> <li>- Bicycle lane</li> <li>- Barrier protected bicycle lane/cycle track in activity centers and/or high traffic areas</li> </ul>
<b>Functional Classification : Major Collector</b>	<ul style="list-style-type: none"> <li>- Gather traffic from local roads and channel then onto the arterial network</li> <li>- Generally serve intra-community travel and provide less mobility and greater land access than arterials</li> <li>- Feature moderate speed limits and traffic volumes (3,000-12,000 ADT)</li> </ul>	<ul style="list-style-type: none"> <li>- Generally, one or two through lanes per direction with a central left turn lane</li> <li>- On-street parking may be considered in activity centers or urban areas with commercial activity</li> <li>- Number of lanes should support current or near-term term project traffic volume; excessive capacity should be avoided.</li> <li>- Narrower lanes may be considered in activity centers or locations with high pedestrian volumes</li> </ul>	<ul style="list-style-type: none"> <li>- Bicycle lane</li> <li>- Sharrows/shared lane where volumes and speeds are low</li> </ul>
<b>Functional Classification : Minor Collector</b>	<ul style="list-style-type: none"> <li>- Offer a high degree of land access and some degree of mobility for motorists</li> <li>- Penetrate residential neighborhoods and distribute trips from local roads to the arterial network</li> <li>- Utilized for short distances and feature lower speeds and traffic volumes (under 6,000 ADT) than major collectors</li> </ul>	<ul style="list-style-type: none"> <li>- Generally one through lane in each direction; may feature center turn lane</li> <li>- On-street parking may be considered in activity centers or urban areas with commercial activity</li> </ul>	<ul style="list-style-type: none"> <li>- Bicycle lane</li> <li>- Sharrows/shared lane where volumes and speeds are low</li> </ul>

**TABLE 7.4.27 Roadway Functional Classification Descriptions (source: FHWA and LRTS Guide)**

	Description	Design Considerations	Bicycle Infrastructure Options
<b>Functional Classification : Local Roads</b>	<ul style="list-style-type: none"> <li>- Provide a high degree of land access, including most roads within residential areas</li> <li>- Support short trips at low speeds.</li> <li>- Bus routes generally do not run on local roads</li> <li>- The DPM identifies three types of local roads - major, normal, and access - with modest design differences</li> </ul>	<ul style="list-style-type: none"> <li>- Narrow roadways, though there should be sufficient width to support emergency vehicle access</li> <li>- On-street parking is generally provided</li> <li>- Major local roads may function in a similar manner to minor collectors and may contain similar design features</li> </ul>	<ul style="list-style-type: none"> <li>- Bicycles generally travel with the flow of traffic</li> </ul>

### Section. 7-4(B)(4) Right of Way Ranges

#### 7-4(B)(4)(i) [General Considerations](#)

The required right-of-way is a starting point for determining the roadway features that can be accommodated and how to balance modes and desired street elements. Right-of-way ranges should not be understood as encouraging the maximum roadway footprint or the inclusion of all possible roadway features. Roads that are especially wide can accommodate many types of roadway needs and uses, but may make conditions uncomfortable for cyclists, pedestrians, and transit users due to the nearby traffic volume or vehicle speeds, and may require pedestrians to cross long distances.

Per the LRTS Guide, the minimum right-of-way should be set-aside to meet the expected needs of the roadway. Right-of-way can be minimized if desired roadway elements, such as bicycle facilities, are incorporated on nearby facilities, or if there is sufficient roadway network density that vehicle travel can be dispersed across many roads and the width of an individual roadway can be limited without compromising auto mobility needs.

#### 7-4(B)(4)(ii) [Major Roads](#)

Right-of-way requirements for all roads classified as arterials or collectors are determined by the LRTS Guide and are provided in [TABLE 7.4.28](#) below. Greater levels of right-of-way are required for roads with higher functional classification; principal arterials have a larger right-of-way envelope than minor arterials, and minor arterials are wider than collectors.

**TABLE 7.4.28 Right-of-Way Ranges for Major Roads**

Roadway Type	Right-of-Way Range
<b>Regional Principal Arterial</b>	106 – 156'
<b>Community Principal Arterial</b>	96 – 130'
<b>Minor Arterial</b>	82 – 124'
<b>Major Collector</b>	62 – 100'
<b>Minor Collector</b>	48 – 84'

7-4(B)(4)(iii) [Local Roads](#)

Right-of-way widths for local roads are provided in [TABLE 7.4.28](#). See [Part. 7-5\(J\) Local Streets](#) for additional information.

**TABLE 7.4.29 Right-of-Way Ranges for Local Roads**

Corridor Type	Location / Subdivision Type	Right-of-Way Width
<b>Access Local</b>	City Wide	44'-46'
<b>Normal Local</b>	Single Family Residential Areas	48'-52'
	All Other Areas	48'-61'
<b>Major Local</b>	Single Family Residential Areas	48'-58'
	All Other Areas	50'-73'

7-4(B)(4)(iv) [Application to Existing Roads](#)

Limited right-of-way on existing facilities may provide constraints on the available options and force designers to make choices and tradeoffs among street elements. Corridor designations are therefore useful in prioritizing how the available right-of-way should be allocated. Additional right-of-way may be considered but is not required for existing roadways if they are below the ranges provided in the DPM.

## Part. 7-4(C) City of Albuquerque-Bernalillo County Comprehensive Plan

### Section. 7-4(C)(1) General Purpose

The Comp Plan is the policy document jointly adopted by the City of Albuquerque and Bernalillo County that describes the community's vision for the future and identifies desired policy outcomes. In practice, the Comp Plan guides discretionary decisions about changes to zoning, development proposals, and public investment decisions. The supporting Integrated Development Ordinance (IDO) is a regulatory document that governs more specific land use considerations, including zoning, subdivision regulations, and site development standards.

Although it is primarily a land use document, the Comp Plan addresses many issues confronting the City of Albuquerque that are inter-related and must be addressed in a coordinated manner. From a transportation perspective, the plan emphasizes increased transportation options, travel demand management strategies to manage congestion, and connectivity for all modes through “networks for vehicles, bicycling, walking, and transit that provide easy and safe access to employment, amenities, and services.” The Comp Plan emphasizes not only investments in public transit and infrastructure for non-auto modes, but a more comprehensive examination of the streetscape.

### **Section. 7-4(C)(2) Implications for the DPM**

The Comp Plan contains tools and policies to encourage complementary land uses and transportation infrastructure. The link between land use and transportation in the Comp Plan is built around the Centers and Corridors framework, which is summarized in the [Comp Plan Vision Map](#). The Centers and Corridors framework “prioritizes infill and growth in more urban areas and discourages growth in more rural and undeveloped areas” and asserts that “creating multi-modal corridors that connect centers within Albuquerque will be an important element of mobility in the future.” For this framework to be successful, Corridors must have the right infrastructure to enable safe travel within Centers, to connect destinations, and support the needs of a range of users. This policy guidance is expanded into design standards throughout Chapter 7 of the DPM.

In addition to design standards by Corridor type, **policy matrices** provide general guidance on street design elements and indicate transportation priorities by location.

### **Section. 7-4(C)(3) Comp Plan Corridors**

While the LRTS Guide regional role designations and the roadway functional classification determine the amount of right-of-way that is allocated, the Comp Plan applies Corridor designations that reflect the different functions that roadways may fulfill and the travel modes that should be incorporated into street design.

The Comp Plan Corridors comprise a network of roadways that collectively meet the travel needs of Albuquerque and Bernalillo County residents. The network approach means that some Corridors prioritize certain modes over others (See [TABLE 7.4.30](#)). For example, Commuter Corridors are facilities that play a critical role in the mobility of single-occupancy vehicles (Commuter Corridors are generally consistent with the Regional Principal Arterials designations on the LRRS). Premium Transit and Major Transit Corridors are roadways where space may be allocated for dedicated travel lanes, while Main Street and Multi-modal Corridors balance the needs of various users.

**TABLE 7.4.30 Relationship among Corridor Types**

Functional Classification	Long Range Roadway System	Comp Plan Designation
Principal Arterial	Regional Principal Arterial / Community Principal Arterial	Premium Transit
		Major Transit
		Multi-Modal
		Commuter
		Main Street
		Other

*Note: Some minor arterials are designated in the Comp Plan; however, there are no LRRS designations for minor arterials and all minor arterials have the same right-of-way requirements. All principal arterials are identified on the LRRS as either a regional or community principal arterial.*

Land use and development patterns are also intended to vary by Corridor type. For example, land uses along Major Transit and Main Street Corridors and around Premium Transit Station Areas should include a mix of uses and pedestrian-oriented design. Commuter Corridors are intended for long-distance trips across town by automobile, including limited-access streets, and development along Commuter Corridors should be more auto-oriented. Where Corridors

**TABLE 7.4.31 Comp Plan Corridor Designations**

Corridor Designation	Description	Examples
<b>Premium Transit</b>	Premium Transit Corridors are intended to feature high-quality, high-capacity, high-frequency public transit (e.g. bus rapid transit). These corridors are planned for mixed-use and transit-oriented development within walking distance from transit stations at strategic locations along the corridor, with adequate transitions to single-family neighborhoods behind the corridor.	Central Ave, University Blvd
<b>Major Transit</b>	Major Transit Corridors are anticipated to be served by high frequency and local transit (e.g. Rapid Ride, local, and commuter buses). These corridors prioritize transit above other modes to ensure a convenient and efficient transit system. Walkability on these corridors is key to providing a safe and attractive pedestrian environment, as well as good access for pedestrians, cyclists, and transit users to goods and services along these Corridors and the Centers they connect.	San Mateo Blvd, Lomas Blvd, Coors Blvd
<b>Main Street</b>	Main Street Corridors are intended to be lively, highly walkable streets lined with local-serving businesses. Main Street Corridors are active areas with buildings usually placed right up to the sidewalk, with parking available on-street and to the sides or behind buildings. Main Street Corridors should be well-served by transit with pedestrian amenities such as street trees, landscaping, and wide sidewalks.	Central Ave, 4th St (north of Downtown), Bridge Blvd (South Valley)

TABLE 7.4.31 Comp Plan Corridor Designations		
Corridor Designation	Description	Examples
<b>Multi-Modal</b>	Multi-modal corridors are intended to encourage the redevelopment of aging, auto-oriented commercial strip development to a more mixed-use, pedestrian-oriented environment that focuses heavily on providing safe, multi-modal transportation options. The development of these corridors will enhance the environment for pedestrians and transit users, while nearby parallel streets (if available) may serve bicycle travel.	Isleta Blvd, Menaul Blvd, Paradise Blvd
<b>Commuter</b>	Commuter Corridors are higher-speed and higher-traffic volume routes for people traveling across town, usually via limited-access roadways. Access controls on these corridors influence the location and mix of land uses and the design of development. Development sites along Commuter Corridors should be buffered from the roadway. Motor vehicles are prioritized on these corridors, though safe conditions for pedestrians may be supported through landscaping, buffers, and medians.	Unser Blvd, Paseo del Norte, Gibson Blvd, Tramway Blvd
<b>Other</b>	Some roadways, including all collectors and the majority of minor arterials, do not have a Comp Plan Corridor designation.  Undesignated corridors do not serve a function that specifically requires any particular mode to be prioritized over others. Per the Complete Streets Ordinance, these corridors require consideration of all users. Design for undesignated corridors should be based on the functional classification.	Juan Tabo Blvd, Academy Blvd

**Note:** Premium Transit Corridor designations function as an overlay on top of a primary Comp Plan Corridor designation. Design standards in the DPM are generally provided for Premium Transit Station Areas, defined as 660' radius around transit facilities. Outside of the Premium Transit Station Areas, the underlying Corridor designation informs roadway design and land use considerations. However, premium transit may require dedicated infrastructure and special design considerations along the length of a corridor.

### Section. 7-4(C)(4) Comp Plan Centers

The design standards contained in the transportation chapter of the DPM often vary depending on whether the site being developed or the roadway passes through a designed Center. Most Centers are areas of relatively intense development characterized by a variety of uses that allow for many different activities. The Comp Plan designates five types of Centers on a spectrum of development density, intensity of land use and activity, and market area size. Consult the Vision Map to determine if a projected is located within a designated Center.



**TABLE 7.4.32 Comp Plan Center Types and Definitions**

Center Type	Description	Examples
Downtown	Albuquerque’s Downtown serves as a regional hub for concentrated job and commercial activity supported by high-density housing and includes a wide variety of land uses. Downtown is intended to have the highest intensity of employment and commercial uses in the region and to offer a high-quality environment for pedestrians. This mixed-use district should include multiple transportation options, street trees, wide sidewalks, and easy-to-use wayfinding signs.	Downtown Albuquerque
Urban Center	Urban Centers are walkable districts that incorporate a mix of employment, service, and residential uses at a density and intensity lower than Downtown but higher than neighborhood-serving Activity Centers. Urban centers are easily accessed by transit and provide opportunities for people to live, work, learn, shop, and play. Urban Centers are intended to become more walkable over time through investments in streetscape amenities, attracting infill development, and locating services closer to nearby residents.	Uptown, Volcano Heights
Activity Center	Activity Centers provide convenient, day-to-day services at a neighborhood scale to serve the surrounding area within a 20-minute walk or a short bike ride. These smaller centers should incorporate pedestrian-friendly design and are appropriate for mixed-use and multi-family housing.	UNM, San Mateo Blvd & Montgomery Blvd, Coors Blvd & Montañó Rd
Employment Center	Employment Centers are intended to remain predominately industrial, business, and retail centers. Employment Centers tend to be auto-oriented and are generally located at major intersections or along highways or major arterials that provide access for trucks and connections for freight. Street design should emphasize efficient movement of vehicles and pedestrian accommodation within business parks.	Journal Center, Kirtland AFB, Albuquerque Sunport
Village Center	Village Centers are located in unincorporated areas of Bernalillo County and are not considered in the DPM. Village Centers include a variety of retail and commercial services.	N/A

### Section. 7-4(C)(5) Policy Matrices

Roadways should contain different features depending on the Corridor type, surrounding land use, and whether a roadway design is being developed for inside or outside a designated Center. The policy matrices contained in the Comp Plan – described below and summarized in [TABLE 7.4.33](#) – provide guidance on how street design and development form should vary depending on the location and context. These matrices should be referenced during the roadway design process. Various aspects of the matrices have been incorporated into the DPM; for example, the acceptable level of service (LOS) determined through a traffic impact study varies depending on the location.

The street design policy matrix indicates desired urban form and roadway characteristics by Corridor type and location. Design considerations include: access management, design speed, peak hour LOS, priority travel mode, transit accommodations, signalized intersections, on-street parking, pedestrian facilities and streetscape improvements, sidewalk width, landscaping and buffers, and bicycle facilities. The matrix differentiates between desired roadway form inside and outside of designated Centers or Premium Transit Station Areas. Many of these characteristics are built into the design standards of the DPM, though the matrices should be considered for additional guidance on the desired urban form and street design context.

The priority street elements matrix takes the street design matrices a step further by providing guidance on which travel modes and street elements to prioritize along designated Corridors. As not all street elements can or should be included along a particular roadway, the matrix provides direction on how to balance and prioritize the available right-of-way with the needs of various users in different locations and contexts.

Two land use development form matrices – one for designated Centers and a second along designated Corridors – identify the desired land use mix and provide guidance on parking and characteristics of the built environment. An important difference by location is the relationship between the buildings and the street, including setbacks and building access.

**TABLE 7.4.33 Comp Plan Matrices – Descriptions and Relevance to DPM**

Matrix	Location	Description	Relevance to DPM
Street Design Policy Matrices – Corridors	Chapter 6: Transportation – Policies by Corridor type (6.1.4-6.1.9)	General guidance on desired roadway character and the types of roadway elements that would ideally be incorporated along each Corridor type. Identifies desired size and scale of roadway elements and accommodations for alternative modes.	Identifies roadway character through guidance related to Corridor type and land use context. The DPM is the source of design specifications.

**TABLE 7.4.33 Comp Plan Matrices – Descriptions and Relevance to DPM**

Matrix	Location	Description	Relevance to DPM
Street Elements Matrix	Chapter 7: Urban Design – Policies on Development Form (7.1.3 – Table 7-5)	Identifies which modes and roadway features should be accommodated within the public right-of-way given the surrounding land use context. The extent of available right-of-way may force designers to make tradeoffs and balance between needs.	Informs desired street elements and provides policy guidance for prioritizing elements within limited right-of-way. The street elements priority matrix should be used in combination with the dimensions outlined in the DPM standards.
Development Form Matrix – Centers	Chapter 7: Urban Design – Policies on Development Form (7.1.3 – Table 7-3)	Identifies general land use mix, characteristics of the built environment, and relationship between buildings and the street within designated Centers. Guidance includes setbacks, building access, parking requirements, and parking location.	Contains considerations related to block length, site access, and desired level of network connectivity.
Development Form Matrix – Corridors	Chapter 7: Urban Design – Policies on Development Form (7.1.3 – Table 7-4)	Identifies general land use mix, characteristics of the built environment, and relationship between buildings and the street along linear Corridors. Guidance includes setbacks, building access, parking requirements, and parking location.	Contains considerations related to block length, site access, and desired level of network connectivity.

**Section. 7-4(C)(6) Other Considerations**

Other designations in the Comp Plan are important to note as they influence the intended form and function of certain areas within the City, but are not generally incorporated into roadway design standards contained in DPM. All Centers and Corridors, with the exception of Commuter Corridors, are considered **Areas of Change**. These locations are intended to be supported by transit service and pedestrian travel opportunities, and contain land use patterns that encourage additional growth, higher levels of density, and more intense levels of development. **Areas of Consistency** are locations where existing land use regulations take precedent and where zoning changes are discouraged. All new development in areas of consistency should be at the scale and intensity of surrounding neighborhoods. Commuter Corridors, which promote auto travel, are areas of consistency.

## **Part. 7-4(D) City of Albuquerque Complete Streets Ordinance**

### **Section. 7-4(D)(1) Definition of Complete Streets**

Per the City of Albuquerque Complete Streets Ordinance, Complete Streets are defined as follows: “roadway(s) with Cross-Sections (including public right of way and public or private easements abutting a public right of way that are designated for a roadway) built at a human scale, designed and operated for equal access by all users, including pedestrians, bicyclists, motorists and transit riders of all ages and abilities, to allow comfortable and convenient street crossings, and pedestrian access to adjacent land uses. Complete Streets components include, but are not limited to, sidewalks, bike lanes, dedicated bus lanes, comfortable and accessible public transportation stops, frequent and comfortable pedestrian crossing opportunities, median pedestrian islands, accessible pedestrian signals, curb extensions and pedestrian bulb-outs, reduced travel lane widths determined by the design speed of the roadway, context-appropriate curb return radii, roundabouts, or other features that accommodate efficient multimodal travel.”

### **Section. 7-4(D)(2) Purpose of Ordinance**

The City of Albuquerque’s Complete Streets Ordinance, passed in 2014, calls for formal consideration of multi-modal roadway elements as part of the street design and re-design process in established areas of the City. The Complete Streets Ordinance follows a similar resolution passed by the Metropolitan Transportation Board of MRMPPO and responds to the fact that “much of Albuquerque’s existing roadway system was built to facilitate access to destinations by personal automobile, resulting in streets that are uninviting and impractical for other users.” In their place, roadways should be designed to be context sensitive and to create multiple transportation options, where practical. To achieve this, roads should balance sufficient vehicle mobility needs with sidewalks, bicycle lanes, transit amenities, traffic calming measures, and convenient pedestrian crossings.

### **Section. 7-4(D)(3) Street Design and Implementation**

The Complete Streets Ordinance requires that roadways be redesigned during “all major projects,” including rehabilitation and reconstruction, to address multi-modal infrastructure that does not meet design standards. The Ordinance specifically applies to arterial and collector roadways located in the City’s “Established Urban Areas” and to corridors “designated a Complete Street by resolution of the City Council of action of the Mayor.” The Ordinance does not apply to basic maintenance projects such as patching, cleaning, or sidewalk repair that do not involve resurfacing, restriping, or reconfiguring the roadway.

Multi-modal infrastructure is to be introduced through traffic calming techniques, narrowing and/or removing general purpose lanes and reallocating space to other users, introducing parallel parking, and by providing buffers between vehicle traffic and pedestrian and bicycle facilities.

### **Section. 7-4(D)(4) Connection between the Complete Streets Ordinance and the DPM**

The DPM incorporates Complete Streets principles and design considerations across the City of Albuquerque to ensure that multi-modal transportation infrastructure and context-sensitive design solutions are contained in all roadway redesign and new construction projects. Complete Streets design principles are most heavily emphasized in the design standards for designated Centers and Corridors and through the policy matrices contained in the Comp Plan.

The DPM User Guide outlines the steps to be followed by city staff or contractors during roadway redesign or new construction projects. The design review process applies to all roads classified as collector or above and requires designers to examine the existing infrastructure and determine whether or not desired street elements are presently available. The User Guide also identifies the relevant planning guidance that should be considered for prioritizing roadway elements, including regional transit and bicycle corridor designations, the Comp Plan Center and Corridor types policy matrix, as well as the modal priorities matrix.

## **Part. 7-4(E) Principles of Network Design and Roadway Connectivity**

The Comp Plan emphasizes that roadway networks be designed in ways that promote transportation options and make destinations as accessible as possible. This section provides additional background on the purpose and intent of network design principles discussed in the LRTS Guide and the Comp Plan and their implications for roadway design. Specific guidance related to connectivity standards is located in [Article 7-5 Design Standards](#) of the DPM.

### **Section. 7-4(E)(1) Connectivity**

Connectivity affects the ability of travelers to efficiently reach their destinations; it is a function of the number of intersections, or intersection density, and the layout of the roadway network. Well-connected networks include numerous intersections, shorter block lengths, and few dead-end roads. Benefits of connectivity include: direct travel routes between destinations, which reduces VMT and improves air quality; dispersing traffic across multiple roadways to reduce congestion, including during traffic incidents; providing better emergency vehicle access; and creating shorter and more direct bicycle and pedestrian routes. Well-connected networks can also help avoid situations where property access falls directly onto arterials.

The LRTS Guide provides general guidance and strategies for improving connectivity and ensuring that transportation networks work for all users. Connectivity strategies include large-scale measures such as the presence of

regional networks by travel mode and establishing standards for intersections per square mile and roadway spacing, as well as smaller-scale strategies such as utilizing access easements and drainage utilities for creating connections, and wall breaks or paths that provide access from residential subdivisions to the external transportation network.

**FIGURE 7.4.44 Pedestrian Access to Cul De Sac Street Example**



The IDO specifies that new subdivisions include neighborhood-level roadway networks that connect to and are integrated with the regional transportation system. In addition to the design of roadways themselves, the best means of ensuring this integration is through standards related to block length and intersection density. Local roads also support the regional network by ensuring adequate access to regional roads, and the layout of local roads is critical to developing highly-connected networks that better support non-motorized travel.

### **Section. 7-4(E)(2) Regional Connectivity and Spacing of Major Roads**

The network of arterial and collector roadways provides connections across the City of Albuquerque and the larger region. These major roads should be spaced at regular intervals as the most efficient roadway networks in urban areas provide nearby parallel streets to allow for flexibility and route options. The regional roadway network layout should emphasize redundancy with many route options. Networks that rely on a few large-scale high-capacity roadways should be avoided as they generally become congested, inhibit pedestrian circulation, and compromise safety.

Per ITE access management guidance, the spacing between arterials should be no more than one mile apart. The network layout and level of connectivity should support the desired development and land use patterns, and the spacing of arterials and collectors should balance traffic flow demands with needs of non-motorized travel modes. Arterials may be spaced as close as one-half mile apart in areas with high levels of pedestrian activity, such as Downtown or an Urban Center. Arterials and collectors should be spaced more closely together in areas within denser networks and shorter block lengths. Larger spacing is more appropriate in rural and residential areas, though the network must provide adequate bicycle and pedestrian connections.

Arterials and collectors should be interspersed to create a system of thoroughfares and parallel facilities that collectively meet the needs of a range of users.

Guidance for the spacing of signalized intersections and designated pedestrian crossings are provided in [Part. 7-5\(E\) Pedestrian Facilities](#)

### Section. 7-4(E)(3) Neighborhood Connectivity

The layout and density of local streets within a neighborhood influences internal circulation patterns as well as access to the external roadway network. Local roads should provide short, direct routes that connect residential neighborhoods with commercial areas, schools, other neighborhoods, and arterials where transit service is most likely to be found.

Bicycle and pedestrian access to the external roadway network should be provided at regular intervals (i.e. no more than ¼-mile apart). If street connections are not feasible or not appropriate for the location, access may be provided via wall breaks. Bicycle routes on neighborhood streets that are parallel to arterials also provide a safe and comfortable alternative to cyclists rather than traveling along on-street bike lanes on arterials.

Cul-de-sacs and stub streets are generally prohibited as they limit the ability to access the regional roadway network. See section 14-16-4-3.3.A.4 of the IDO (Stubs Streets and Cul-de-Sacs) for exceptions. See [Part. 7-5\(J\) Local Streets](#) for additional guidance on discontinuous streets.

### Section. 7-4(E)(4) Intersection Density

Intersection density refers to the number of intersections in the road network for a particular area. Intersection density is a function of block length, road layout, and parcel size, and should be considered during the planning of medium and large-scale developments.

Greater intersection density and shorter block lengths are most appropriate in Comp Plan-designated Centers and Premium Transit Station Areas that promote high levels of pedestrian activity. Intersection density may be lower and block lengths may be longer in residential and industrial areas, or commercial areas and Employment Centers with low levels of pedestrian activity.

Sufficient intersections should be provided within residential neighborhoods to allow for the circulation of pedestrians and cyclists and to permit access to the regional network. [TABLE 7.4.34](#) provides guidance on intersection density, adapted from the LRTS Guide to City of Albuquerque land use designations.

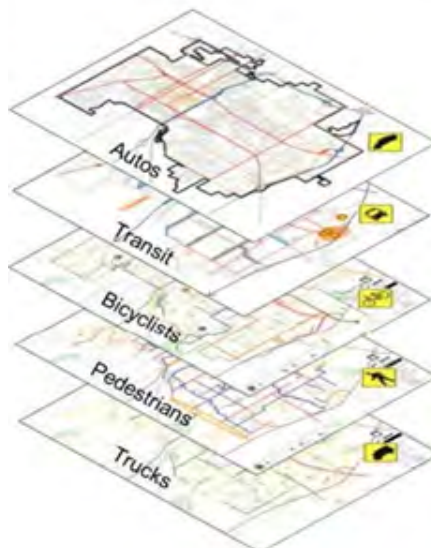
<b>TABLE 7.4.34 Intersection Density by Location, LRTS Guide</b>	
<b>Location</b>	<b>Intersection Density</b>
<b>Downtown</b>	100-200 / sq mi
<b>Urban Center</b>	80-120 / sq mi
<b>Activity Center</b>	60-100 / sq mi
<b>Employment Center</b>	40-100 / sq mi
<b>Residential Areas</b>	30-50 / sq mi
<b>Other Areas</b>	30-50 / sq mi



## Section. 7-4(E)(5) Regional Network Considerations

### 7-4(E)(5)(i) [Layered Roadway Networks](#)

FIGURE 7.4.45 **Layered Networks**



The spacing of arterials and collectors and intersection density standards support layered roadway networks that provide route choice and create opportunities for all modes across the larger system. Each individual roadway does not have to meet the needs of all users if there are accessible facilities on nearby parallel routes. Rather, roadway networks should be created to encourage pedestrian and bicycle travel across the system and to enable freight movement on key corridors. Bicycle facilities may be preferable on nearby parallel roads (either a parallel collector or local road) with lower speeds and traffic volume than principal arterials.

### 7-4(E)(5)(ii) [Limited Access Facilities](#)

MRMPO maintains an inventory of limited access roadways across the AMPA. These roadways are subject to additional guidance with regards to intersection spacing and the intervals between traffic signals. The MRMPO roadway access policies should be consulted for projects located along designated limited access facilities.

## ARTICLE 7-5 DESIGN STANDARDS

### Part. 7-5(A) Network Connectivity

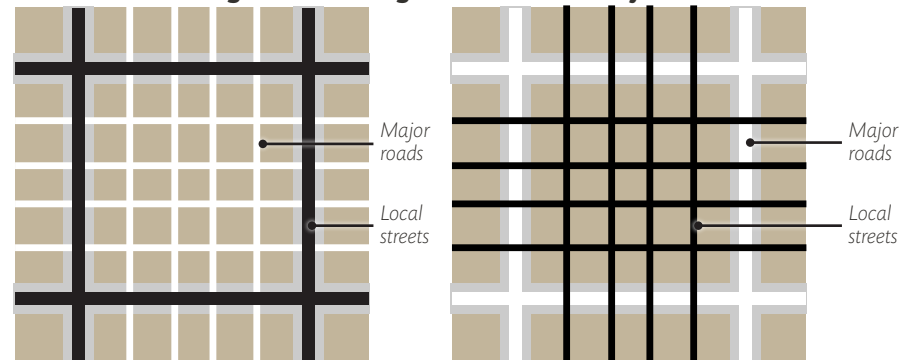
#### Section. 7-5(A)(1) Purpose of Section

This section provides guidance on the spacing of major roads, the general layout of roads, block lengths, pedestrian crossings, and the expectations for integrating road design and site development with the regional transportation system as defined in the Long Range Roadway System Map.

#### Section. 7-5(A)(2) Definition of terms

1. **Regional roadway network** refers to the system of collector and arterial roadways (also referred to as major roads) that provide mobility and access across the city. See [FIGURE 7.5.46](#).
2. **Neighborhood roadway network** refers to the local streets, often in a residential area, that are surrounded by the regional roadway network.

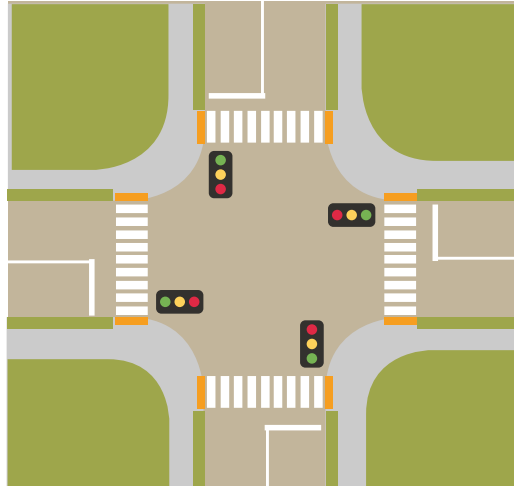
FIGURE 7.5.46 Regional and Neighborhood Roadway Networks



3. **Arterial/collector spacing** refers to the distance between major roads along a corridor. Unless there is a grade separation, intersections of collectors and arterials are controlled by traffic signals.
4. **Block length** refers to length of roadway between two intersections. The intersections at the end of blocks maybe signalized or unsignalized depending on the roadway type.
5. **Designated pedestrian crossing** refers to the location where pedestrians are encouraged to cross a roadway, as indicated by a combination of signal devices, signage, or pavement markings. See [Section. 7-5\(A\)\(7\)](#) for additional information.
6. **Signalized pedestrian crossing** refers to a designated pedestrian crossing in which traffic is forced to stop and the pedestrian is protected via a traffic signal or pedestrian-activated signal device.
7. **Signalized intersection** refers to intersection locations where vehicles are managed through a traffic signal. Pedestrian crossings are typically provided at signalized intersections.
8. **Mid-block crossing** refers to a form of designated pedestrian crossing that is not located at an intersection. Mid-block crossings serve to provide direct access to destinations and to reduce the distances between intersections with designated crossings.

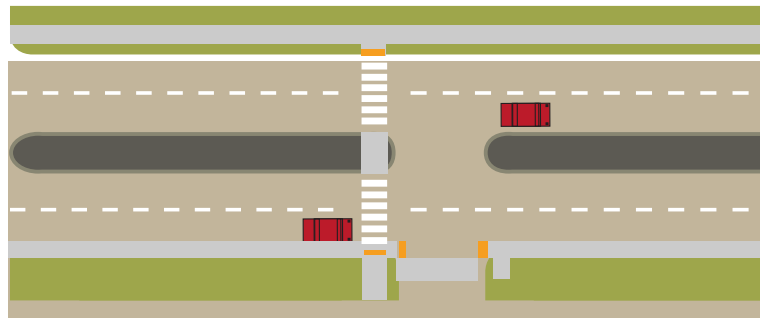
9. **Controlled Pedestrian Crossing** refers to a location where vehicles in all directions are managed with traffic control devices which may facilitate pedestrian crossing. See [FIGURE 7.5.47](#).

**FIGURE 7.5.47 Controlled Pedestrian Crossing Example**



10. **Uncontrolled Pedestrian Crossing** refers to a location where pedestrians may cross a roadway where vehicles are not controlled. Pedestrian crossings with pavement markings and signage are an example of both uncontrolled and designated pedestrian crossing. See [Section. 7-5\(A\)\(7\)](#) for guidance regarding designated pedestrian crossings and [FIGURE 7.5.47](#).

**FIGURE 7.5.48 Uncontrolled Pedestrian Crossing Example**



11. **Designated Pedestrian Crossing** refers to the location where pedestrians are encouraged to cross a roadway, as indicated by a combination of signal devices, signage, or pavement markings. See [Section. 7-5\(A\)\(7\)](#) for additional information.
12. **Signalized Pedestrian Crossing** refers to a designated pedestrian crossing in which traffic is forced to stop and the pedestrian is protected via a traffic signal or pedestrian-activated signal device.
13. **Signalized Intersection** refers to intersection locations where vehicles are managed through a traffic signal. Pedestrian crossings are typically provided at signalized intersections.
14. **Mid-block Crossing** refers to a form of designated pedestrian crossing that is not located at an intersection. Mid-block crossings serve to provide direct access to destinations and to reduce the distances between intersections with designated crossings.

### Section. 7-5(A)(3) Connectivity

Connectivity affects the ability of travelers to efficiently reach their destinations. The following network characteristics standards (see [TABLE 7.5.35](#)) are intended to promote well-connected networks, including numerous intersections, shorter block lengths, and adequate pedestrian crossings. See [Article 7-4 Roadway Design Context](#) for additional discussion.

Location	Arterial / Collector Spacing	Block Length	Signalized Pedestrian Crossing <sup>1</sup>	Designated Pedestrian Crossing <sup>1</sup>
Downtown	1,320-2,640' (¼ to ½-mile)	200-400'	≤660' (⅛-mile)	≤400'
Urban Center	1,320-2,640' (¼ to ½-mile)	300-400'	≤660' (⅛-mile)	≤400'
Activity Center	1,320-2,640' (¼ to ½-mile)	400-600'	≤1,320 (¼-mile)	≤600'
Employment Center	≤2,640' (½-mile)	≤800'	≤2,640' (½-mile)	As appropriate <sup>2</sup>
Village Center	1,320-2,640' (¼ to ½-mile)	400-600'	≤1,320 (¼-mile)	≤600'
Other Areas / Local Streets	≤2,640' (½-mile)	≤600'	≤2,640' (½-mile)	As appropriate <sup>2</sup>
Main Street Corridor	1,320-2,640' (¼ to ½-mile)	300-400'	≤660' (⅛-mile)	≤400'

#### 7-5(A)(3)(i) [Regional Connectivity and the Spacing of Major Roads](#)

1. [TABLE 7.5.35](#) provides the spacing between arterials and collectors (i.e. major roads). This table does not differentiate between principal and minor arterials or major and minor collectors, since the most important consideration from a connectivity perspective are the frequency of major roads.
2. The spacing between arterials should be no more than one mile apart. Arterials may be spaced as close as one-half mile apart in areas with high levels of pedestrian activity, such as Downtown or Urban Centers.
3. Arterials and collectors should be interspersed to create a system of thoroughfares and parallel facilities that collectively meet the needs of a range of users.
4. Arterials and collectors should be spaced more closely together in areas within denser networks and shorter block lengths. Larger spacing is more appropriate in rural and residential areas, though the network must provide adequate bicycle and pedestrian connections.

<sup>1</sup> Indicates the values are recommended and strongly encouraged.

<sup>2</sup> See Section. 7-5(A)(7) and FIGURE 7.5.51.

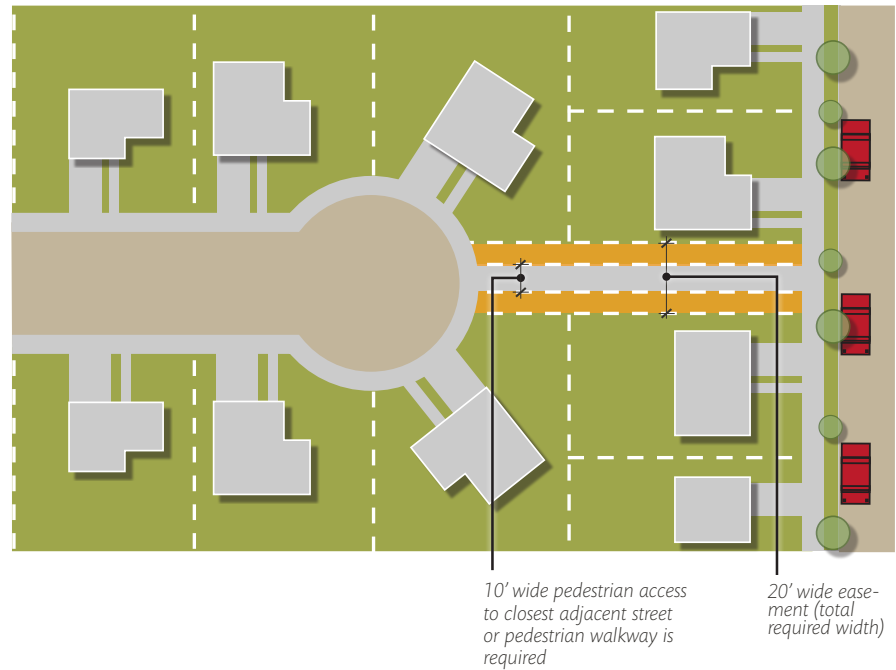
### 7-5(A)(3)(ii) Neighborhood Connectivity

1. Local streets shall provide short, direct routes that connect residential neighborhoods with commercial areas, schools, other neighborhoods, and arterials where transit service is most likely to be found (See [FIGURE 7.5.49](#)).
2. Bicycle and pedestrian access points shall be provided to the regional roadway network or existing bicycle facility at least every ¼-mile. If street connections are not feasible or not appropriate for the location, access may be provided via wall breaks (see [FIGURE 7.5.49](#) and [FIGURE 7.5.50](#)).
3. Cul-de-sacs and stub streets limit the ability to access the regional roadway network. Cul-de-sac and stub streets are prohibited, with the following exceptions:
  - a. Cul-de-sacs are allowed where necessary to avoid those types of sensitive lands listed in [IDO Section 14-16-5-2\(C\)](#), or where vehicular safety factors make a connection impractical, such as, but not limited to size or shape or lots, topography, surrounding development patterns, and physical characteristics.
  - b. Permanent stub streets are allowed only where a connection to an existing street and a future road extension is not possible or feasible. Where allowed, stub streets are limited to 150 feet in length.
  - c. Mid-block “bubble” cul-de-sacs without throats are allowed.
  - d. Whenever cul-de-sac streets are created, one 20-foot wide pedestrian access/public utility easement shall be provided, between the cul-de-sac head or street turnaround and the sidewalk system of the closest adjacent street or pedestrian sidewalk or pathway, unless the city engineer determines that public access in that location is not practicable due to site or topography constraints.
4. See [Part. 7-5\(J\) Local Streets](#) for additional guidance on discontinuous streets and residential access via a single driveway.

FIGURE 7.5.49 Neighborhood Connectivity



FIGURE 7.5.50 Cul-de-Sac with Pedestrian Access



## Section. 7-5(A)(4) General Network Considerations

### 7-5(A)(4)(i) [General Block Layout](#)

Blocks shall follow a square or rectilinear grid system, where feasible. Alignments may vary depending on topography, to protect natural features, to respond to site constraints, or to meet the needs of a particular set of land uses.

### 7-5(A)(4)(ii) [Major Roads and Designated Centers](#)

1. Arterials and collectors shall provide direct connections to designated Centers.
2. Major roads should comprise a network in which a series of parallel facilities collectively meet the needs of all users and provide sufficient capacity within designated Centers. See [Article 7-4 Roadway Design Context](#) for additional discussion.
3. Networks should be designed to ensure delivery trucks are accommodated and may reach their destinations. Accommodations for large delivery trucks (i.e. greater than SU-30) are not required on all roads.
4. Commuter Corridors should pass along the edges rather than through a Comprehensive Plan-designated Center. Where Commuter Corridors pass through or bisect Centers, the road design should transition to a typical section that supports the adjacent land use with slower design speeds and improved access to businesses and residential areas.

### 7-5(A)(4)(iii) [Limited Access Facilities](#)

Consult the [MRCOG roadway access policies](#) for designated limited access facilities. These roadways are subject to additional guidance with regards to drive-ways, intersection spacing and the intervals between traffic signals.

### 7-5(A)(4)(iv) [Right-of-Way Allocation](#)

See [Article 7-4 Roadway Design Context](#) for the required right-of-way allocation by functional classification for new roadways. Per the LRTS Guide, right-of-way values at the low end of the range are most appropriate if there is a high density of parallel facilities. Narrower facilities also reduce barriers for pedestrians and cyclists when crossing the street.

## Section. 7-5(A)(5) **Block Lengths**

### 7-5(A)(5)(i) [General Provisions](#)

1. Block length refers to the distance along a roadway between intersections. Block lengths vary depending on the roadway type and whether the roadway is located in a Comprehensive Plan-designated Center, with shorter block lengths most appropriate in high pedestrian-activity areas.
2. See [TABLE 7.5.36](#) for block lengths by location.
3. The maximum block length for collectors and arterials is 600 feet, except where access limitations are applied.
4. Along limited access facilities, business access or backage roads are strongly encouraged with pedestrian connections to the arterial provided every 600 feet or less.
5. The maximum block length along local streets is 600 feet (see [IDO Section 14-16-5-4\(E\)\(3\)\(b\)](#) for exceptions). See [Part. 7-5\(J\) Local Streets](#) for guidance on cul-de-sacs and stub streets.
6. Mid-block crossings shall be considered and are strongly encouraged for new streets in the following circumstances:
  - a. *Downtown and Urban Centers and along Main Street Corridors where block lengths exceed 400 feet. The mid-block crossing shall be located at the middle of the block to the greatest extent feasible.*
  - b. *Other areas and any new development where block lengths exceed 600 feet. The mid-block crossing shall be located at the middle of the block to the greatest extent feasible.*
7. See the section below on Designated Pedestrian Crossings for more information on crossings at intersections and mid-block locations.

## Section. 7-5(A)(6) **Traffic Signal Spacing**

### 7-5(A)(6)(i) [General Provisions](#)

1. Traffic signals are located at intersections to manage the flow of traffic and allow for safe pedestrian crossing. See [Section. 7-5\(I\)\(6\)](#) for additional information on traffic control devices.
2. Standards for intervals between traffic signals can be found in [TABLE 7.5.36](#). Outside of designated Centers, traffic signal spacing less than ¼-mile is discouraged and requires approval by the City Engineer.

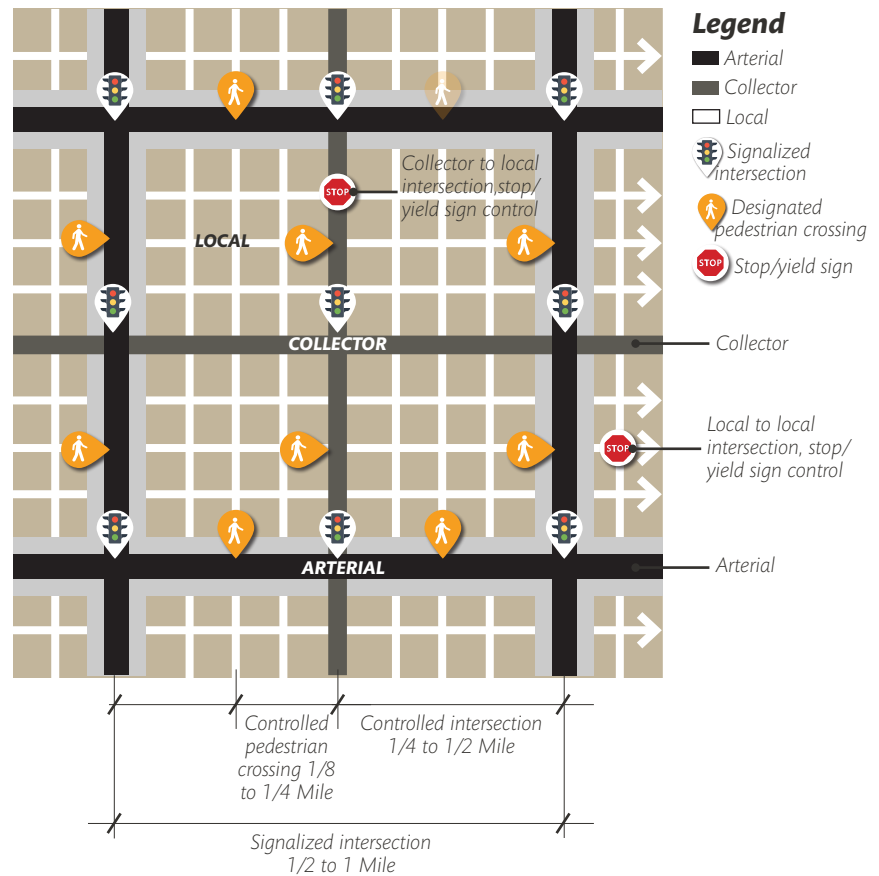


3. Unless the intersection is grade-separated, all intersections between arterial and collector roadways shall be controlled with signalized pedestrian crossings.
4. Intersections where arterials and collectors intersect with local streets may be unsignalized. See [FIGURE 7.5.51](#) for an example of the spacing of traffic signals and pedestrian crossings.
5. Intersections involving two local streets are generally served by stop or yield-sign controls.
6. Along high auto volume roadways, such as Commuter Corridors, signalized intersections should be evenly spaced and at intervals that ensure efficient flow of vehicles (generally ½-mile).
7. The spacing between signals along Major Transit, Multi-modal, and Main Street corridors should be at the low end of the range provided in [TABLE 7.5.36](#), where practical, to ensure greater connectivity and opportunities for pedestrian crossings.
8. Within Comprehensive Plan-designated Centers, signalized intersections may be appropriate at intervals below the distance ranges provided in [TABLE 7.5.36](#).

**TABLE 7.5.36 Recommended Distance between Signalized Intersections by Corridor Type**

Corridor	Distance between Signalized Intersections	Distance between Signalized Pedestrian Crossings
<b>Major Transit</b>	1,320-2,640' (¼ to ½-mile)	1,320 (¼-mile)
<b>Multi-Modal</b>	1,320-2,640' (¼ to ½-mile)	1,320 (¼-mile)
<b>Main Street</b>	1,320 (¼-mile)	660' (1/8-mile)
<b>Commuter</b>	2,640-5,280' (½ to 1-mile)	2,640' (½-mile)
<b>Other Arterial</b>	2,640' (½-mile)	2,640' (½-mile)
<b>Minor Arterial</b>	1,320-2,640' (¼ to ½-mile)	1,320 (¼-mile)
<b>Collector</b>	1,320-2,640' (¼ to ½-mile)	1,320 (¼-mile)

FIGURE 7.5.51 Example Layout - Signalized Intersections & Pedestrian Crossings



## Section. 7-5(A)(7) Designated Pedestrian Crossings

### 7-5(A)(7)(i) Definitions and Appropriateness

1. The locations where pedestrians are encouraged to cross a roadway, as indicated by a combination of signal, signage, or pavement markings. While motorists are required by state law to stop for pedestrians crossing a roadway within a crosswalk, some forms of pedestrian crossings provide a higher level of safety and comfort than others. The type of crossing infrastructure depends on the location, traffic volume, and other considerations (see warranting criteria below in [7-5\(A\)\(7\)\(iii\)\(a\)](#)).
2. Designated pedestrian crossings may be located at unsignalized or signalized intersections, and may be protected via a traffic signal or pedestrian-activated signal device, or unprotected with elements such as flashing beacons, pavement markings, and signage.

### 7-5(A)(7)(ii) Types of Designated Crossings

1. A higher level of safety and comfort for pedestrians are provided by traffic control signals, including pedestrian hybrid beacons that completely stop the flow of traffic through a pedestrian-activated sensor.

2. The crossing types listed in [TABLE 7.5.37](#) below are ordered from higher to lower form of safety and comfort.
3. Multiple measures should be combined at a crossing, such as a marked crosswalk and a pedestrian refuge island.
4. Traffic volume and the number of lanes of traffic that must be crossed should be considered when determining the most appropriate type of designated pedestrian crossing.
5. See the [FIGURE 7.5.52](#) for pedestrian crossing examples and [Part. 7-5\(E\) Pedestrian Facilities](#) for guidance on crosswalk design and pedestrian refuge islands.
6. See the [MUTCD](#) for guidance on signage type and placement and considerations for the installation of hybrid and flashing beacons.

TABLE 7.5.37 Designated Pedestrian Crossing Types		
	<b>Controlled Locations</b>	Traffic control device (signal or stop signs)
		Pedestrian hybrid beacon
	<b>Uncontrolled Locations</b>	Flashing beacon (rapid rectangular flash beacon, in-pavement flashers)
		Pedestrian refuge island
		Signage (in-street, overhead, or sign post)
		Marked crosswalk (no signs or signals)

FIGURE 7.5.52 Pedestrian Crossing Examples



### 7-5(A)(7)(iii) [Frequency of Pedestrian Crossings](#)

#### 7-5(A)(7)(iii)(a) *General Warranting Criteria*

1. Designated pedestrian crossings shall be provided at regular intervals (see [TABLE 7.5.35](#)), with un-signalized crossings available in between signalized crossings as appropriate, and with the frequency of designated pedestrian crossings depending on the location, block length, and the type of corridor. More frequent crossings shall be provided along corridors with high levels of pedestrian activity and within designated Centers.
2. Designated pedestrian crossings should be provided at intersections unless blocks exceed desired lengths, in which case mid-block crossings may be considered.
3. Designated pedestrian crossings should be provided with sufficient frequency to ensure the following:
  - a. The maximum distance between designated crossings in Downtown and Urban Centers and along Main Street Corridors is 400'.
  - b. The maximum distance between designated crossings in Village Centers and Activity Centers is 600'.
  - c. The maximum distance between designated crossings for other areas (including residential neighborhoods) should be 1320' unless there is no

pedestrian activity in the area. Additional crossings may be provided as appropriate.

4. Designated pedestrian crossings should also be provided in the following situations:
  - a. Within 100' of a transit station area and 400' of a transit stop.
  - b. At special generators, including schools, hospitals, recreational sites, event centers, or major shopping/retail sites.
  - c. Areas with identified safety concerns, as demonstrated through a Road Safety Audit, crash rates above the regional average, or the result of other studies or data collection efforts.
5. Designated pedestrian crossings at locations other than those specified by the DPM should be supported by a study or pedestrian count information documenting that a crossing is warranted at the location.
6. Designated pedestrian crossings may be required at the discretion of the City Engineer, and may be omitted with the approval of the City Engineer.
7. Uncontrolled pedestrian crossings should not be provided in high-volume traffic locations or other situations that are not conducive to safe pedestrian travel. See [7-5\(A\)\(7\)\(iii\)\(c\)](#) for additional guidance.

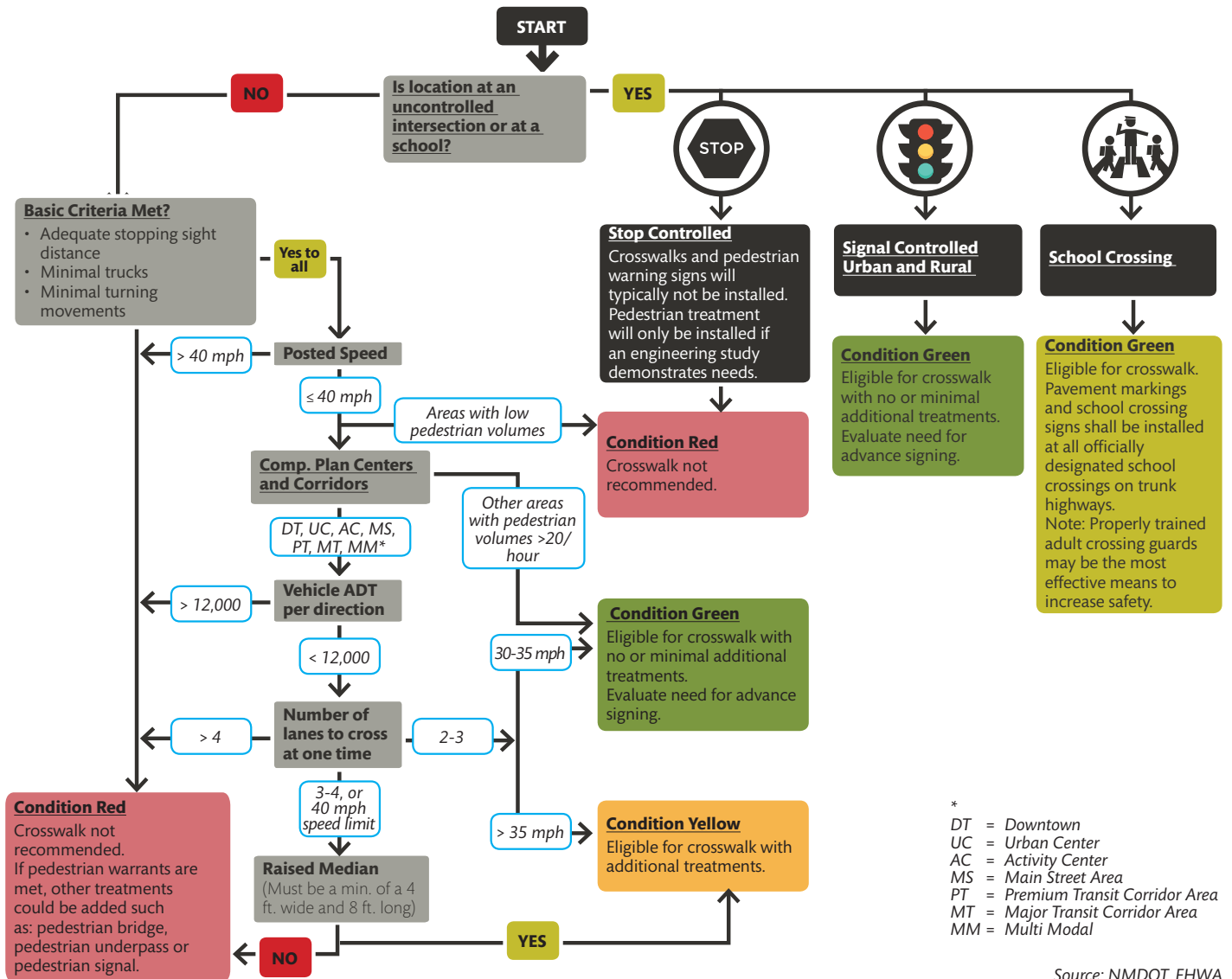
#### **7-5(A)(7)(iii)(b) Signalized Pedestrian Crossings**

1. Signalized pedestrian crossings (e.g., traffic signals or pedestrian hybrid beacons) should be provided in the following situations, also see [TABLE 7.5.35](#):
  - a. All at-grade intersections with a traffic signal.
  - b. Every 660 feet (1/8-mile) or less within Downtown and Urban Centers and along Main Street Corridors.
  - c. Every 1,320 feet (1/4-mile) or less in Activity Centers and Village Centers and along Major Transit and Multi-Modal Corridors.
  - d. Every 2,640 feet (1/2-mile) or less in all other circumstances, unless no pedestrian activity is present or is unlikely to be present in the future.

#### **7-5(A)(7)(iii)(c) Considerations for Unsignalized Pedestrian Crossings**

1. In some cases, including situations:
  - a. without adequate stopping sight distance,
  - b. where traffic volumes exceed 12,000 vehicles per day, and
  - c. where there are more than 3 total general purpose lanes of traffic (and unless there is a median refuge).
    - i. Introducing an unsignalized crossing may make conditions less safe for pedestrians by creating a false sense of security. In these situations, unsignalized pedestrian crossings are generally discouraged. See [FIGURE 7.5.53](#) for decision path to determine the criteria and level of control to install pedestrian crossings.
2. See the [National Cooperative Highway Research Program \(NCHRP\) Report 562 Improving Pedestrian Safety at Unsignalized Crossings](#) and the [FHWA publication Safety Effects of Marked Versus Unmarked Crosswalks at Uncontrolled Intersections](#) for additional guidance on appropriate locations for unsignalized pedestrian crossings.
3. The City Engineer may elect not to approve the installation of an unsignalized pedestrian crossing if the location is not supported by the criteria provided in [FIGURE 7.5.53](#).

FIGURE 7.5.53 Pedestrian Crossing Decision Path



7-5(A)(7)(iii)(d) Consideration of Mid-Block Crossings during Reconstruction Projects

1. Mid-block crossings shall be considered and are strongly encouraged during roadway reconstruction projects in Downtown, Urban Centers, and along Main Street Corridors where existing block lengths exceed 400 feet.
2. Mid-block crossings shall be considered and are strongly encouraged during roadway reconstruction projects where existing block lengths exceed 600 feet and where pedestrians are present, including high pedestrian activity areas such as schools.
3. Mid-block crossings are strongly encouraged where two major pedestrian generators are located on opposite sides of the street and are separated by a collector or arterial roadway, or to provide direct access to a school where no designated crossings are nearby.

4. The spacing of traffic signals must be evaluated during the consideration of mid-block crossings. See the MUTCD for guidance on traffic signal spacing

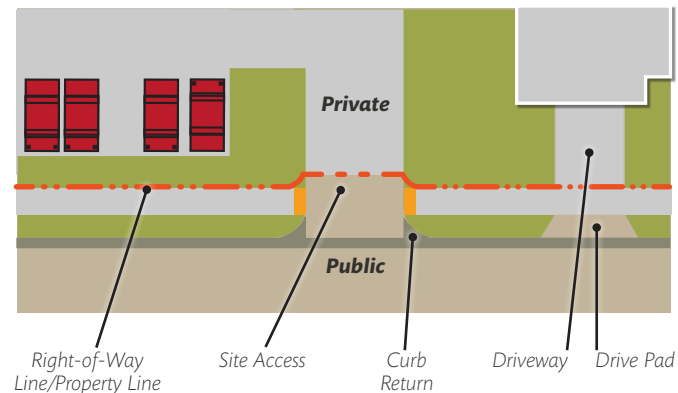
## Part. 7-5(B) Site Access Points

### Section. 7-5(B)(1) Definitions

Curb returns and drivepads provide site access points for residential and commercial properties. See [FIGURE 7.5.54](#)

1. Driveway – An area on private property where vehicles and bikes are operated or allowed to stand.
2. Drivepad – The portion of a driveway in the right of way that connects a street to a commercial or residential driveway which is typically at sidewalk grade.
3. Curb Return – The curved section of curb connecting a street to an intersecting street or driveway, both of which are typically at the street grade.

FIGURE 7.5.54 Site Access Elements



### Section. 7-5(B)(2) General Guidance and Curb Cut Ordinance

1. The frequency of site access points depends on the functional classification of the corridor and whether the roadway is located in a residential or non-residential area.
2. Per the Comp Plan, there should be minimal driveways in high pedestrian activity areas to reduce conflicts between motorists and pedestrians. Closely spaced site access points conflict with safe pedestrian movement by increasing vehicle crossings over sidewalks and by reducing on-street parking.
3. Site access points should be limited along Commuter Corridors and other auto-oriented areas in order to manage access and improve traffic flow.
4. The Curb Cut Ordinance regulates the location, dimensions, and frequency of site access points along the public rights-of-way.
5. Shared Site Access Points: driveways that straddle property lines, or are entirely on one property but are to be used by another property, shall have an access easement. Sufficient area behind the drivepad for the proper operation of the driveway must also be included.
6. Abandoned Site Access Points: per the Curb Cut Ordinance, any abandoned site access points must be replaced with sidewalk, curb, and gutter

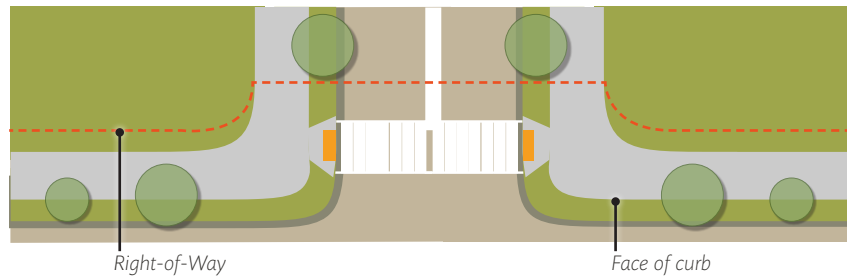
by the property owner. As a part of a public roadway project, after 30 day notice, the City may close abandoned site accesses.

7. The driveway or intersecting road behind a curb return shall be flush with and of the same material as the paved section of the intersecting roadway.
8. Alternate materials for the site access point may be approved by the City Engineer.

**Section. 7-5(B)(3) Pedestrian Access**

1. Pedestrian access is required to all properties in the City of Albuquerque. See [Part. 7-5\(E\) Pedestrian Facilities](#) for requirements and design guidelines.
2. All site access points shall be ADA/PROWAG compliant.
3. The curb ramp and transitions shall be fully located within the public right-of-way or public sidewalk easement.
4. Right-of-way or public roadway easement is required to be dedicated as shown in [FIGURE 7.5.55](#).

**FIGURE 7.5.55 Right-of-Way Dedication**



**Section. 7-5(B)(4) Vehicular Access**

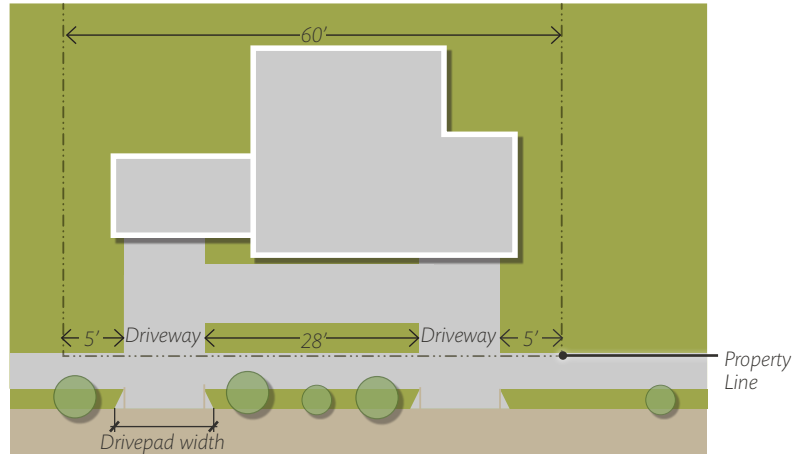
1. All site access points to City of Albuquerque roads shall be approved by the Traffic Engineer.
2. Sites are accessed through drivepads or curb returns. See [Section. 7-5\(B\)\(5\)](#) for locations where curb returns are permitted and the number of site access points allowed per site.
3. Low Density Residential Site Access Points
  - a. Residential drivepads and driveways shall be designed per [TABLE 7.5.38](#). The associated dimensions are also illustrated in [FIGURE 7.5.56](#) through [FIGURE 7.5.57](#).
  - b. The dimensions given in this section are for the width of the driveway at the drivepad / property line.
  - c. Location and dimensions for driveways shall be designed per [FIGURE 7.5.56](#) through [FIGURE 7.5.58](#).
  - d. Site access points shall not be located on major streets (i.e. collector or arterial streets) unless that is the only street available for access to a property.
  - e. For residential properties with two access points, driveways shall be spaced at least 28' apart from each other.

<b>TABLE 7.5.38 Low Density Residential Driveways</b>	
<b>Standards</b>	<b>Dimensions</b>
<b>Driveway width</b>	12-22'
<b>Minimum distance between driveways</b>	28'
<b>Minimum distance from property line</b>	5' 6"



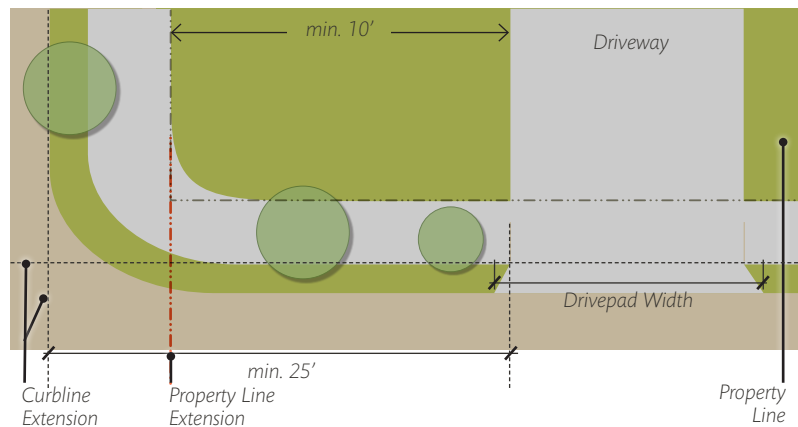
TABLE 7.5.38 Low Density Residential Driveways	
Minimum frontage for two driveways	60'
Shared site access point maximum allowed width	40'

FIGURE 7.5.56 Low Density Residential Driveway Location and Dimensions



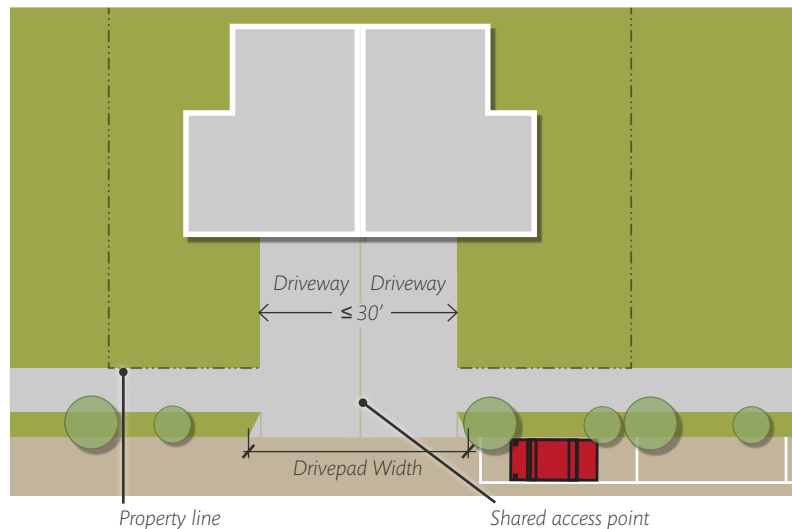
- f. Driveways shall be a minimum 5' from the property line as illustrated in [FIGURE 7.5.56](#) and [TABLE 7.5.38](#) to ensure the drivepad is separated from the property line sufficiently.
- g. The drivepad may be built at the property line if both of the following instances are present:
  - h. The driveway for the adjacent lot is on the far side of the lot,
  - i. The owner presents a letter from the adjacent property owner agreeing to the reduction in separation from drivepad and property line.
- j. Driveways located on corner properties shall be located as shown in [FIGURE 7.5.57](#). The driveway should be 25' from face of the curb-line extension or 10' from the property line extension. Whichever distance is greater from the corner governs.
- k. Driveway width may be increased to 30' if requested to allow access to a three car garage or to park a recreation vehicle or boat.

FIGURE 7.5.57 Driveway Distance From Intersection



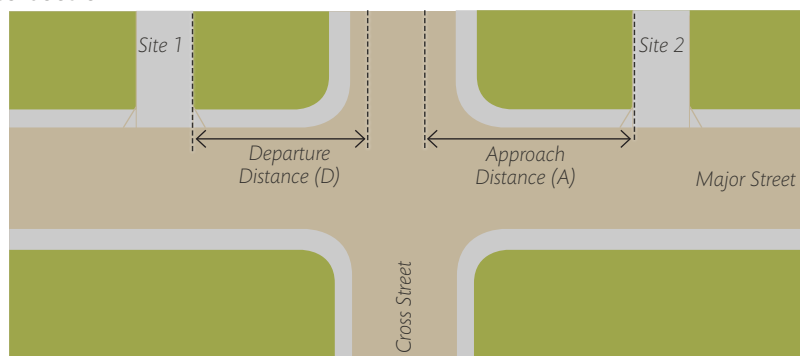
4. Shared Site Access Points
  - a. For small lots (i.e. 40' frontage or less), the site access should be shared by two lots, leaving area for a minimum of one on-street parking space, as illustrated in [FIGURE 7.5.58](#).
  - b. Shared access driveways may be separated beyond the back of the sidewalk.
  - c. The maximum width of the shared access point allowed is 30'.

**FIGURE 7.5.58 Low Density Residential Shared Access Point**



5. Multi Family, Mixed Use, and Non-residential Site Access Points
  - a. Location of site access points should include the following considerations:
    - i. Minimum distance from an intersection (see [Figure 3.2-6](#) and [Table 3.2-2](#)).
    - ii. Maximum number of site access points allowed by corridor type per site (see [Table 3.2-3](#)).
  - b. Site accesses should be evenly spaced in areas where more than one driveway per site is proposed.
  - c. All dimensions are measured from the curb face or driveway edge.
  - d. See the run lane and median design section for additional guidance on the spacing of median openings.

**FIGURE 7.5.59 Commercial Site Access Points and Distance From Intersection**



**TABLE 7.5.39 Low Density Residential Driveways**

Type of Street	Cross-Street Classes					
	Arterial		Collector		Local	
	A	D	A	D	A	D
Principal Arterial	300'	200'	200'	150'	150'	100'
Minor Arterial	200'	150'	150'	100'	100'	100'
Major Collector	150'	150'	100'	100'	75'	75'
Minor Collector	150'	150'	100'	100'	75'	75'
Local (additional distance may be required based upon queuing)	75'	75'	50'	50'	25'	25'

**TABLE 7.5.40 Maximum Number of Commercial Site Access Points per Site**

Type of Street	
Principal Arterials	1-2 access points per 300' frontage
Minor Arterials	1-2 access points per 200' frontage
Collectors	1 access point per 100' frontage

**Section. 7-5(B)(5) Curb Return Design**

**7-5(B)(5)(i) Curb Return Access Guidelines**

1. Curb returns rather than drivepads are recommended on collectors and arterials and may be appropriate under the following circumstances:
  - a. For high volume traffic generators (e.g., over 25 vehicles entering or exiting per hour)
  - b. Development has median access with 25 or more parking spaces
  - c. Developments with 50 or more required parking spaces
2. Curb returns are permitted on Local Streets when a site has more than 50 parking spaces.
3. One-way drives are only permitted where the circulation is self-enforcing (e.g., when angle parking and one way aisles are used to establish the one-way pattern from entrance to exit).
4. The width and radius of the entrance are dependent upon the design vehicle. The design vehicle is generally an SU-30, though a smaller design vehicle is encouraged where feasible. See [Section. 7-5\(1\)\(6\)](#) for additional information.

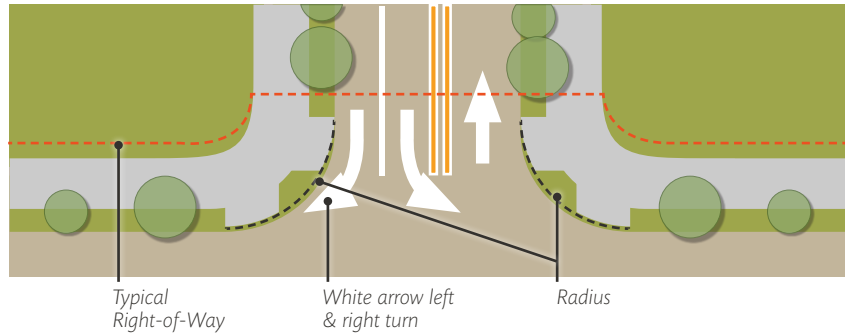
**7-5(B)(5)(ii) Curb Return Access Widths**

1. Widths of site access points shall be per [Table 3.2-4](#).
2. Additional width may be permitted for median. See [Figures 3.2-7 and 3.2-8](#) for typical curb return access layout.
3. Narrower site access points shall be provided in Comp Plan-designated Centers, along Transit, Multi-modal, and Main Street corridors, and locations with high-pedestrian activity levels.

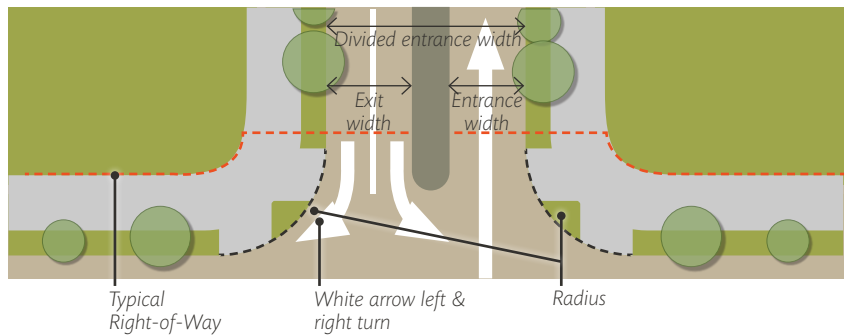
**TABLE 7.5.41 Driveway Widths for Arterial, Collector, and Local Streets**

Entrance	Arterial & Collector	Local Streets
One-Way Drives	20' – 25'	12' – 20'
Two Lane Drives	22' – 30'	22' – 24'
Three Lane Drives	24' – 35'	22' – 30'
Larger Vehicles (WB-40 or larger)	Max 50'	Max 30'

**FIGURE 7.5.60 Curb Return Access Point**



**FIGURE 7.5.61 Divided Entrance Width**



**7-5(B)(5)(iii) Curb Return Access Radii**

1. Curb radii shall be per [TABLE 7.5.42](#).
2. See [Section. 7-5\(I\)\(6\)](#) for additional guidance.
3. Smaller radii shall be provided in Comp Plan-designated Centers, along Transit, Multi-modal, and Main Street corridors, and locations with high-pedestrian activity levels.

**TABLE 7.5.42 Curb Return Radii by Design Vehicle – Single Entrance/Exit Widths**

Design Vehicle	Maximum Radius at Flow Line
Car Only	15'
SU-30 (Single unit truck-30' long wheel base 20' (refuse truck))	25'
WB-40 (Tractor trailer-50' long-wheel base 40')	30'

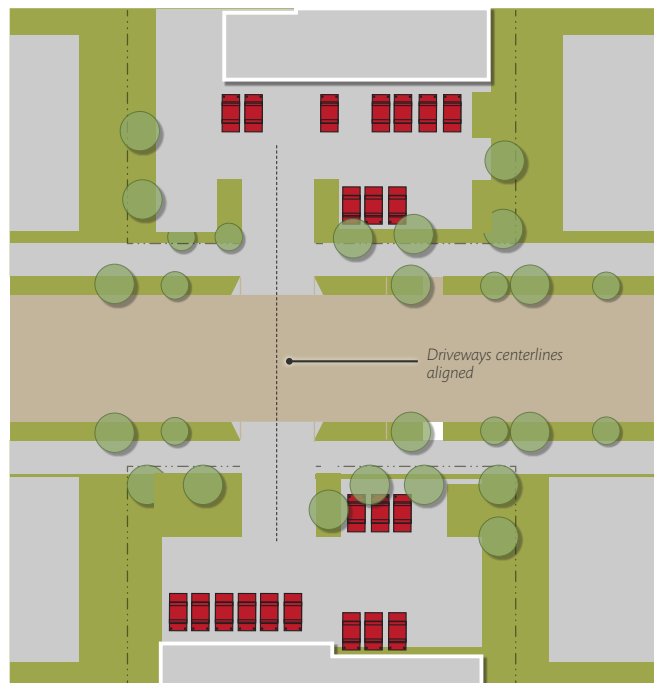
**TABLE 7.5.42 Curb Return Radii by Design Vehicle - Single Entrance/Exit Widths**

WB-50 (Tractor trailer-55' long-wheel base 50' (18 wheeler))	35'
--	-----

**Section. 7-5(B)(6) Access Control**

1. See the [MRCOG](#) inventory of limited access roadways for locations where site access may be limited. Contact the Traffic Engineer in the Transportation Development Division or visit the MRCOG website at for additional information.
2. Limited Access Roadways are typically located on principal arterials or on the interstate/frontage road system. This restriction may apply to the entire roadway length or individual segments.
3. Where drivepads/access points are to be constructed on opposite sides of the street, the centerlines need to be as closely aligned as conditions allow (see [FIGURE 7.5.62](#)). Drivepads/access points do not need to be aligned if they are offset by 50' or more .
4. Where a median opening is desired, access to both sides of the street shall be considered. If development exists on both sides of the street, left turn bays for both directions may need to be constructed. For streets with medians, access points need to be placed such that the centerline of the drivepads/access points are as closely aligned as conditions allow on the median openings.
5. Streets or driveways with median access points shall be placed such that the centerline of the access points are as closely aligned as conditions allow on the median openings.
6. If access points cannot be aligned, it is desirable to have them offset so that potential left turn paths do not cross and [AASHTO Case F Sight Distance](#) is accommodated.

**FIGURE 7.5.62 Non Residential Driveways with Aligned Centerline**



### **Section. 7-5(B)(7) Striping and Signage**

1. Site access points with three or more lanes require striping and arrows to define proper usage by entering and exiting vehicles. See City of Albuquerque [Standard Drawings](#) and the latest [MUTCD](#) for additional information.
2. Appropriate signage needs to be included with the construction of any commercial site access point. This may include one way, exit, entrance, and turn restriction signs.

### **Section. 7-5(B)(8) Roadways in NMDOT Jurisdiction**

A driveway permit from the District 3 office is required for roadways under [NMDOT](#) jurisdiction, in addition to City concurrence. To learn the boundaries for NMDOT roadways, contact the Traffic Engineer.

## **Part. 7-5(C) Pavement Design**

### **Section. 7-5(C)(1) General Provisions**

The sections below provide requirements for the subgrade materials evaluation, traffic analysis, and design of flexible pavements, rigid pavements, and alternative pavements. Either the methods below or the design procedure from the New Mexico Department of Transportation (NMDOT) are acceptable for design of pavements in the City of Albuquerque.

The design method contained herein was developed by the review of various methods which are now, or have been in use by different state transportation departments and/or municipalities within the southwestern United States. These methods were all based on adoption and enhancement of the [1993 Guide for Design of Pavement Structures](#) which was published by the American Association of State Highway and Transportation Officials (AASHTO). These methods were selected due to history of performance and due to the City of Albuquerque being in a specific geographic location where experience can be called upon and certain factors will not change.

Three major overall assumptions which have been made in the development of these design procedures are:

1. That the adequacy of the design will be established by soils and material surveys and laboratory studies.
2. That the design strengths assumed for the subgrade and pavement structure will be achieved through proper construction methods.
3. That an adequate present and projected traffic loading for the analysis period be derived from accurate present and historical data in order to achieve the intended serviceability of the roadway.

### **Section. 7-5(C)(2) Subgrade Materials Evaluation**

#### **7-5(C)(2)(i) [Sampling Methods](#)**

1. The City of Albuquerque has chosen the R-Value test as its means of obtaining a resilient modulus for use in the [AASHTO Guide for Design of Pavement Structures, 1993](#) design equation for flexible pavements.

2. The correlation between R-Value and resilient modulus is presented in [TABLE 7.5.45](#).
3. All soil tests shall be conducted under the supervision of a New Mexico Registered Professional Engineer familiar with soil sampling and testing procedures.
4. The design subgrade soil shall be defined as the upper two feet of the soil under the proposed pavement.

#### **7-5(C)(2)(ii) [Frequency of Testing and Required Elements](#)**

Sampling frequency and techniques for subgrade materials (native and borrowed) shall be as follows:

1. One sample for each type of soil.
2. A minimum of one sample every 300 feet for collector and arterial streets.
3. Two samples per project minimum.
4. One "R" value and proctor sample per each soil condition or three per mile of the poorest soil.
5. At least one and preferably two soil borings should go down to a depth comparable to any potential sewer or water line depth. A moisture determination should be made for each sample.
6. Sampling is to be random and shall not be restricted along any given line, but shall be spread irregularly over the proposed roadway.
7. The depth of sampling shall extend to a minimum depth of 3 feet below proposed subgrade elevation unless rock is encountered.

#### **7-5(C)(2)(iii) [Required Soil Tests](#)**

The following tests shall be performed on soil samples:

1. Sieve Analysis.
2. Plastic Index.
3. Soil correlation/analysis to determine representative soils, on which "R" value tests are to be performed.
4. With approval from the City Engineer, the designer can use [NMDOT Estimated R-value chart](#) based on soil type to supplement actual R-value test results on the subgrade soils encountered. Both the tested and estimated "R" values can be used to determine the design "R" value.
5. "R" value and Proctor density-moisture tests.
6. Stabilization testing if subgrade stabilization is to be considered.
7. Determination of in-situ moisture content.

#### **7-5(C)(2)(iv) [Geotechnical Design Report](#)**

1. Pavement designs for local streets serving residential areas have been standardized and are presented in the [Standard Details, Section 2400](#). These standards are based on an R Value of 50 or greater. Soils investigation as outlined in the Subgrade Materials Evaluation section will be required to determine the nature of subgrade treatment needed to achieve the minimum R Value.
2. A design report shall be submitted for the construction of arterial, collector, or streets located in industrial areas. This report documents the existing pavement section material, thickness, and width and considers the design information regarding the proposed improvements. Any unusual circumstances which could affect design and/or construction should be noted. A



site plan showing boring locations, soil boring logs and soil test results shall be provided.

3. The design “R” value is correlated to the Resilient Modulus (MR) for use in the flexible pavement design nomograph using [TABLE 7.5.43](#).

**TABLE 7.5.43 R-Value and resilient modules (M<sub>r</sub>) correlation\***

R-VALUE	MR	R-VALUE	MR	R-VALUE	MR
0	2176	30	6143	60	17345
1	2252	31	6359	61	17956
2	2331	32	6583	62	18588
3	2414	33	6815	63	19242
4	2499	34	7055	64	19920
5	2586	35	7303	65	20621
6	2678	36	7560	66	21347
7	2772	37	7826	67	22098
8	2869	38	8102	68	22876
9	2970	39	8387	69	23682
10	3075	40	8682	70	24515
11	3183	41	8988	71	25379
12	3295	42	9305	72	26272
13	3411	43	9632	73	27197
14	3531	44	9971	74	28154
15	3656	45	10322	75	29146
16	3784	46	10686	76	30172
17	3918	47	11062	77	31234
18	4056	48	11451	78	32334
19	4198	49	11854	79	33472
20	4346	50	12272	80	34650
21	4499	51	12704	81	35870
22	4658	52	13151	82	37133
23	4822	53	13614	83	38440
24	4991	54	14093	84	39794
25	5167	55	14590	85	41194
26	5349	56	15103	86	42645
27	5537	57	15635	87	44146

**TABLE 7.5.43 R-Value and resilient modules (M<sub>r</sub>) correlation\***

R-VALUE	MR	R-VALUE	MR	R-VALUE	MR
28	5732	58	16185	88 and higher	45700
29	5934	59	16755		

**Section. 7-5(C)(3) Traffic Factors in Pavement Design**

**7-5(C)(3)(i) [Traffic Criteria for Pavement Design](#)**

- The values of Average Daily Traffic (ADT), percent distribution of vehicle types, directional distribution and the growth factor used for the design computations shall be obtained either from the Mid-Region Council of Governments (MRCOG) or through a traffic study conducted by a New Mexico Registered Professional Engineer. The values shall be compared against those in [TABLE 7.5.44](#), and unless the values are based on historical data of more than five years, the greater value shall control.

**TABLE 7.5.44 Traffic Criteria for Pavement Design<sup>1</sup>**

Street Classification	ADT (both directions)	Truck Traffic Percentage				Directional Distribution	Annual Growth Rate
		SUT	STT	MTT	BUS		
Principal Arterial	12,000	3	1	1	*	50%	5%
Minor Arterial	8,500	3	1	1	*	50%	4%
Collector	6,000	3	1	1	*	50%	4%

- On smaller projects, (less than 1000 lineal feet of street construction) where traffic count data is not available and a traffic count study is not warranted, the values in [TABLE 7.5.44](#) may be used, as approved by the City Engineer.
- Pavement shall be designed for 20 years unless approval for an alternate design life is received from the City Engineer.
- Growth Factor is determined from [TABLE 7.5.45](#).

**TABLE 7.5.45 Growth Factor**

Design Period Years	Annual Growth Rate, Percent							
	No Growth	2	4	5	6	7	8	10
1	1	1	1	1	1	1	1	1
2	2	2.02	2.04	2.05	2.06	2.07	2.08	2.1
3	3	3.06	3.12	3.15	3.18	3.21	3.25	3.31
4	4	4.12	4.25	4.31	4.37	4.44	4.51	4.64
5	5	5.2	5.42	5.53	5.64	5.75	5.87	6.11
10	10	10.95	12.01	12.58	13.18	13.82	14.49	15.94

<sup>1</sup> Contact Transit Department (\*) Truck-Single Unit (SUT) Single Trailer (STT) Multi-Trailer (MTT)

TABLE 7.5.45 Growth Factor

Design Period Years	Annual Growth Rate, Percent							
	No Growth	2	4	5	6	7	8	10
15	15	17.29	20.02	21.58	23.28	25.13	27.15	31.77
20	20	24.3	29.78	33.06	36.79	41.00	45.76	57.28
25	25	32.03	41.65	47.73	54.86	63.25	73.11	98.35
30	30	40.57	56.08	66.44	79.06	94.46	113.28	164.49
35	35	49.99	73.65	90.32	111.43	138.24	172.32	271.02

5. The ESAL Vehicle Equivalency Factor (EF) for various vehicle types are as shown in [TABLE 7.5.46](#).

TABLE 7.5.46 ESAL Vehicle Equivalency Factor

Vehicle Type	ESAL Factor
Passenger Car	0.0008
Other 4 wheel vehicle	0.0087
Single Unit Truck	0.1890
Single Trailer Truck	2.3719
Multi-Trailer Truck	2.3187
Bus	0.6808

6. The calculation of the default ESAL (18,000-pound Equivalent Single Axle Load) is as follows:
- $ESAL = AWDT \times 365 \times \text{Growth Factor} (\%SUT \times EF_{SUT} + \%STT \times EF_{STT} + \%MTT \times EF_{MTT} + \%Bus \times EF_{Bus} + \%Auto \times EF_{Auto})$
  - The sum of the different types of vehicles equals 100% and the percentage is entered numerically. For example, 3% is entered as .03.

### 7-5(C)(3)(ii) [Analysis Period](#)

- The analysis period for design shall be 20 years.
- The classification of streets is obtained from the most current [Long Range Roadway System Plan](#).

### 7-5(C)(3)(iii) [Design Lane Traffic Computation](#)

- The following equation will determine the ESAL in the design lane:
  - $ESAL_L = D_d \times D_l \times ESAL$ 
    - $D_d$  = A directional distribution factor, expressed as a percentage, that accounts for the distribution of ESAL units by direction but not less than as shown in [TABLE 7.5.44](#).
    - $D_l$  = A lane distribution factor, expressed as a percentage, that accounts for distribution of traffic when two or more lanes are available in one direction ([TABLE 7.5.47](#)).

\* The table is based on the equation  $\text{Growth Factor} = ((1+r)^n - 1) / r$  where  $r = \text{rate}/100$  and is not 0.

**TABLE 7.5.47 Lane Distribution Factor, DL**

No. of Lanes in Each Direction	Percent ESAL in Design Lane
1	100
2	90
3	70
4	65

7-5(C)(3)(iv) [Example ESAL Calculation](#)

Example for a 4-lane, minor arterial:

$$ESAL = 8,500 \times 365 \times 29.78 [(0.03 \times 0.1890) + (0.01 \times 2.3719) + (0.01 \times 2.3187) + (0.95 \times 0.0008)] = 4,927,844$$

$$ESAL_L = 0.5 \times 0.9 \times 4,927,844 = 2,217,530$$

**Section. 7-5(C)(4) Structural Design of Pavement**

7-5(C)(4)(i) [Minimum Pavement Component Thickness](#)

The following criteria governing minimum pavement component thickness shall apply to all major (arterial and collector) roadways. These criteria, as listed in [TABLE 7.5.48](#) are derived based on engineering judgment and past experience in construction quality control.

**TABLE 7.5.48 Minimum Pavement Component Thickness**

Pavement Component	Minimum Thickness
Asphaltic Concrete (AC)	4 inches
Cement-Treated Base Course (CTB)	4 inches
Bituminous Treated Base Course (BTB)	4 inches
Aggregate Base Course (ABC)	4 inches
Subbase Material	4 inches
Soil Cement	6 inches
Asphalt Emulsion Treated Soil	6 inches

7-5(C)(4)(ii) [Structural Coefficients of Pavement Components](#)

The following coefficients, listed in [TABLE 7.5.49](#), shall be used for the computation of design structural number for each type of component selected:

**TABLE 7.5.49 Structural Coefficients of Pavement Components**

Plant Mix Seal Coat (PMSC)	N/A	0.25
Asphaltic Concrete (AC)	N/A	0.42
Bituminous Treated Base Course (BTB)	N/A	0.25
Cement Treated Base Course (CTB)	N/A	0.20
Aggregate Base Course (ABC)	1.15	0.10
Sub-base Material	1.00	0.06
Asphalt Emulsion Treated Soil	N/A	Tentative
Soil Cement	N/A	Tentative
Lime Stabilization	N/A	Tentative

1. The layer modification factor is applied to the base course layer coefficient to reflect the drainage or permeability characteristics of the selected base course.
2. Drainage coefficients are not applied to the asphaltic concrete layers, nor to the stabilized subgrade layers.
3. The modification factors may be set to other values than those recommended if the designer chooses.
4. The modification factors will range between 1.00 and 1.15 for bases approaching saturation less than 25% of the time, and base permits water removal within one day.
5. Seek guidance from *AASHTO Guide for Design of Pavement Structures, 1993 Part 2, Section 2.4* for circumstances where the conditions stated do not apply.

a. The structural number is calculated using the depth in inches ( $d_i$ ) for each layer as follows:

$$i \text{ SN} = a_1 d_1 + a_2 d_2 m_2 + \dots + a_i d_i m_i$$

### 7-5(C)(4)(iii) Serviceability Index

The serviceability of a pavement is defined as the ability to serve high-volume automobile and truck traffic. In the design equation, the serviceability index enters into the equation as the lowest index that will be tolerated before resurfacing or reconstruction becomes necessary.

A scale with a range of 0 through 5 was established for present serviceability rating, with a value of 5 as the highest index of serviceability and 0 as the lowest. The initial serviceability ( $P_o$ ) rating and terminal serviceability ( $P_t$ ) rating are recommended to be selected as shown in *TABLE 7.5.50*.

**TABLE 7.5.50 Serviceability Rating\***

Street Classification	Initial Serviceability Rating ( $p_o$ )	Standard Normal Deviation ( $P_t$ )
Principal Arterial	4.2	2.5
Minor Arterial	4.2	2.0
Collector	4.2	2.0

\* The table above is made using the 1993 AASHTO method of calculating ESALs (change in PSI =  $P_o - P_t$ ).

### 7-5(C)(4)(iv) [Reliability and Statistics](#)

The 1993 AASHTO method of calculation incorporates reliability and statistics to account for the degree of certainty how designs will perform as expected over the 20 year analysis period. For use in the 1993 AASHTO equation, recommended Reliability and Standard Deviation values are provided in [TABLE 7.5.51](#) for Principal Arterial, Minor Arterial, and Collector Streets:

<b>TABLE 7.5.51 Reliability and Statistical Values</b>			
<b>Street Classification</b>	<b>Reliability Level</b>	<b>Standard Deviation (<math>S_o</math>)</b>	<b>Standard Normal Deviation (<math>Z_R</math>)</b>
<b>Principal Arterial</b>	85%	0.45	-1.037
<b>Minor Arterial</b>	80%	0.40	-0.841
<b>Collector</b>	75%	0.40	-0.674

Alternatively, the standard normal deviation as a function of reliability level may be chosen as from [TABLE 7.5.52](#). It is not recommended to use a design reliability level of greater than 90%.

<b>TABLE 7.5.52 Standard Normal Deviation Values</b>	
<b>Reliability Level</b>	<b>Standard Normal Deviation (<math>Z_R</math>)</b>
<b>50%</b>	-0.000
<b>60%</b>	-0.253
<b>70%</b>	-0.524
<b>75%</b>	-0.674
<b>80%</b>	-0.841
<b>85%</b>	-1.037
<b>90%</b>	-1.282

### 7-5(C)(4)(v) [Economic Factors](#)

The design engineer is encouraged to investigate the use of various combinations of pavement components in order to derive the most economic design applicable to the project characteristics and structural requirements.

## Section. 7-5(C)(5) **Flexible Pavements Design**

### 7-5(C)(5)(i) [Design Procedure](#)

A nomograph from [AASHTO Guide for Design of Pavement Structures, 1993](#) pavement design has been provided to simplify the solution to the mathematical relationship of the Resilient Modulus value, ESAL, and the structural number ([FIGURE 7.5.63](#)). Pavement structural designs shall be submitted in the format as shown on [TABLE 7.5.53](#). The equation for calculation of ESAL (W18) using [AASHTO Guide for Design of Pavement Structures, 1993](#) is shown below:

$$\log_{10} W_{18} = Z_R S_o + 9.36 \log_{10} (SN + 1) - 0.20 + \left[ \frac{\log_{10} [\text{change in PSI} / (4.2 - 1.5)]}{0.40 + [1094 / (SN + 1)^{5.19}]} \right] + 2.32 \log_{10} M_R - 8.07$$

FIGURE 7.5.63 Design Chart Flexible Pavements

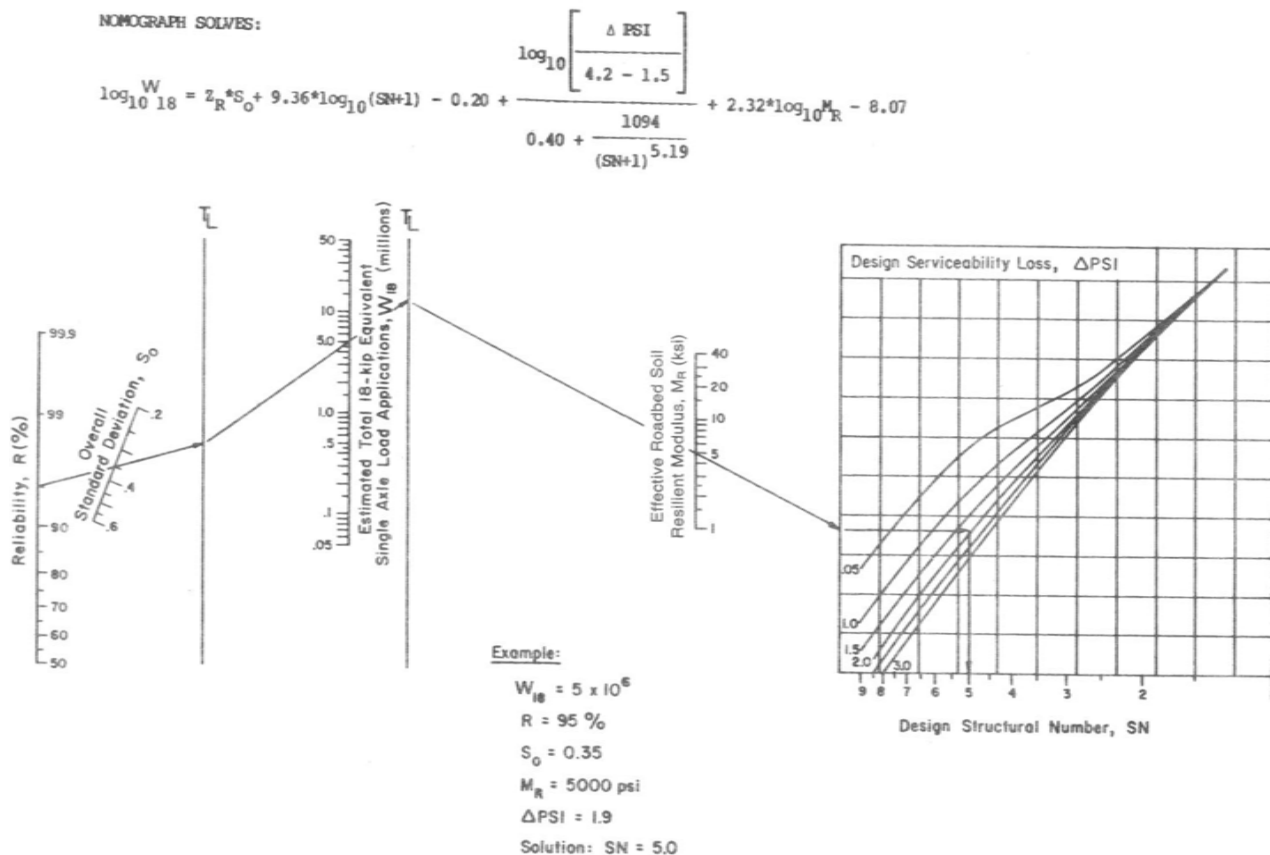


Figure 3.1. Design Chart for Flexible Pavements Based on Using Mean Values for Each Input

TABLE 7.5.53 Structural Design Computation Form

PROJECT NAME: \_\_\_\_\_ STREET: \_\_\_\_\_  
 PROJECT NO: \_\_\_\_\_ FROM: \_\_\_\_\_  
 DESIGN ADL: \_\_\_\_\_ TO: \_\_\_\_\_  
 DESIGN SN: \_\_\_\_\_ COMPUTED BY: \_\_\_\_\_

Alternate	Subbase	CTB	BTB	ABC	AC	PMSC	SN
A	x(0)=	x(.2)=	x(.25)=	x(.1)=	x(.42)=	x(.25)=	
B							
C							
D							
E							
F							

Design SN \_\_\_\_\_



### **Section. 7-5(C)(6) Portland Cement Concrete Design**

The current acceptable method for design of Portland cement concrete pavement is the procedure in the [\*AASHTO Guide for Design of Pavement Structures, 1993\*](#) and the [\*1998 Supplement - Guide for Design of Pavement Structures, Part II\*](#) published by the American Association of State Highway and Transportation Officials, Washington, D.C. As an alternative, the Portland Cement Concrete Pavement (PCCP) design may be determined by use of accepted industry approach and software such as the American Concrete Pavement Association “Street Pave” software or NMDOT procedures.

Concrete pavement joints shall be detailed in the plans. Guidelines for joint layout can be obtained from the [\*American Concrete Pavement Association\*](#).

Design criteria to be used in the structural design of PCCP are as follows:

1. All PCCP shall be fly-ash modified concrete as specified in the Standard Specifications or have other methods of mitigating Aggregate Silica Reaction as approved by the City Engineer.
2. Design of PCCP shall be based on flexural strength value of 600 psi at 28 days as measured by ASTM Method C 78.
3. Stabilized base course values used in conjunction with PCCP designs shall be as indicated below:
  - a. *Portland Cement Stabilized Base – 300 psi compressive strength as measured by ASTM Method D1633.*
  - b. *Asphalt Treated Base – 1000 pound minimum Marshal stability as measured by ASTM Method D1559 (as modified in the [\*Standard Specifications\*](#).)*
4. Reliability shall be 85%.
5. Final Serviceability Index shall be 2.5.

### **Section. 7-5(C)(7) Alternative Pavement**

1. Alternative types of pavement can be used for crosswalks, parking lots, sidewalks, and trails.
2. Where used in the public right of way, approval of proposed design and City's maintenance obligations are required from the City Engineer and the Department of Municipal Development.
3. Alternative materials must have sufficient strength for the projected traffic and require approval of the City Engineer.
4. Crosswalks may be a different material from the remainder of the street.
5. Options for alternative pavement may include but are not limited to:
  - a. *Brick*
  - b. *Pavers*
  - c. *Permeable or Porous Pavement*
  - d. *Stamped Concrete*
  - e. *Gravel*

#### **7-5(C)(7)(i) [Permeable or Porous Pavement](#)**

Requests to use permeable pavement shall include the following items:

1. Geotechnical investigation showing that the subgrade soils have sufficient percolation properties or a design that provides rainwater storage until percolation is achieved.
2. Agreement to maintain the pavement using sweeping, vacuuming or power washing.

3. Product information showing that the pavement meets [American with Disabilities Act \(ADA\)](#) requirements or indicate that a different material is used for ADA accessible parking spaces and accessible route.

## **Part. 7-5(D) Curb and Gutter**

### **Section. 7-5(D)(1) Public Right of Way Requirements**

1. All streets within the City shall have curb and gutter. Exceptions may be granted by the City Engineer in developed areas that predominantly lack curb and gutter and existing right-of-way widths are insufficient to add them.
2. On collectors and above, the standard 8" high barrier-type curb as shown in the [Standard Details](#) must be used as the exterior curb section. Deviation from these standards will require approval of the City Engineer.
3. On local streets, six-inch (6") high barrier-type curb is the standard curb and must be used as the exterior curb section. 8" curb may be used to accommodate drainage requirements.
4. If both traffic and drainage requirements can be met to the satisfaction of the City Engineer, mountable curb types as shown in the [Standard Details](#) may be used on local streets.
5. Mountable curbs may be used in roundabout and/or traffic circle medians.
6. On collectors and above, a 1.5-foot wide gutter pan shall be installed at all curb locations.
7. On local streets, a One-foot (1') wide gutter pan may be installed at all curb locations. Wider gutters may be used to accommodate drainage requirements.
8. The gutter pan is considered as a part of the overall roadway width; it may be included as part of the width of the curbside travel lane and on-street parking space. The gutter pan is not included as a part of the width of a bicycle lane.

### **Section. 7-5(D)(2) Private Property Requirements**

1. Curbs should be used to separate landscaping from parking areas and pedestrian ways in non-single-family residential developments.
2. Curbing or parking blocks should be provided to prevent overhang of parking stalls or circulation of vehicles over sidewalk or right-of-way.
3. A visual barrier needs to be maintained along the public street clearly defining the points of access. Curbs shall be used in conjunction with landscaping as required in the IDO.

## **Part. 7-5(E) Pedestrian Facilities**

The Albuquerque/Bernalillo County Comprehensive Plan emphasizes the provision of a range of safe travel options, including access for pedestrians to all areas of the metropolitan area. As such, all public and private transportation facilities shall include pedestrian appropriate accommodations.

## Section. 7-5(E)(1) Public Sidewalks

### 7-5(E)(1)(i) [General Provisions](#)

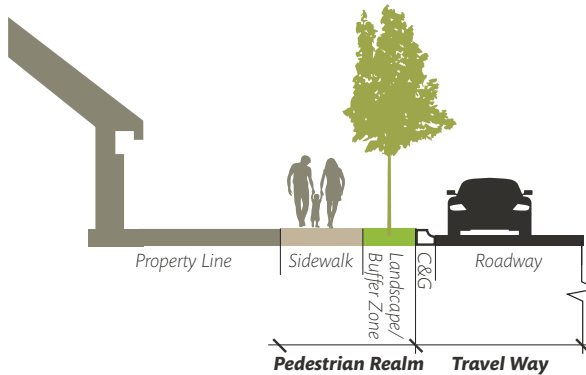
1. All roads in public right-of-way or roadway easements shall include distinct and accessible pedestrian accommodations. Alleyways are exempt from the requirement for separate pedestrian accommodations.
2. All new roadway construction shall include sidewalks and landscape/buffer zones installed on both sides of the street.
3. Roadway reconstruction – defined in this section as any project that includes the construction of new curbs or the horizontal relocation of the curb line – shall include sidewalks and landscape/buffer zones to the greatest extent feasible.
4. Additional right-of-way or easements may be required if any portion of the sidewalk is located outside the existing right-of-way.
5. High pedestrian activity areas are defined as Comp Plan-designated Centers, Main Street Corridors, and Premium Transit station areas, as well as areas surrounding big box stores or clusters of retail activity, school zones, locations where buildings with zero setback are present, and neighborhoods with an average density of 10 units per acre. Multi-modal and Major Transit Corridors may also be considered high pedestrian activity areas depending on the surrounding land uses.
6. See [Chapter 2 Development Procedures](#) of the DPM for general variance procedures.
7. In locations along Comprehensive Plan-designated Corridors with constrained right-of-way the designer should consult the Priority Street Elements Matrix ([Comprehensive Plan Table 7-5](#)) for which elements take precedence.
8. Exceptions to sidewalk and width requirements may be granted in historic neighborhoods, where sidewalks have traditionally not been present, or to match the surrounding character of the residential area. Variances may be granted by the City Engineer within developed areas that predominantly lack sidewalk and where existing right-of-way widths are insufficient to add them.

### 7-5(E)(1)(ii) [Pedestrian Realm Typologies](#)

See [Part. 7-3\(C\) Street Elements](#) for pedestrian realm definitions. Below are the graphic configurations of the pedestrian realm.

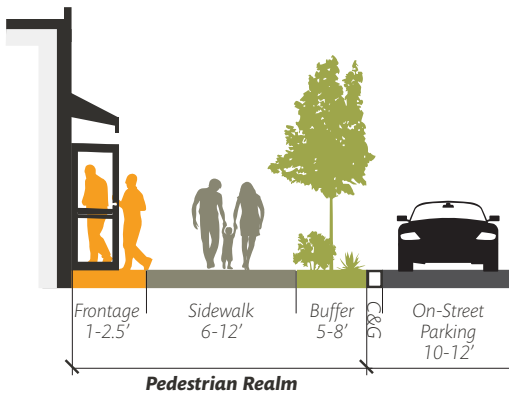
### 7-5(E)(1)(ii)(a) Residential Areas

FIGURE 7.5.64 Residential Area



### 7-5(E)(1)(ii)(b) Mixed Use Areas

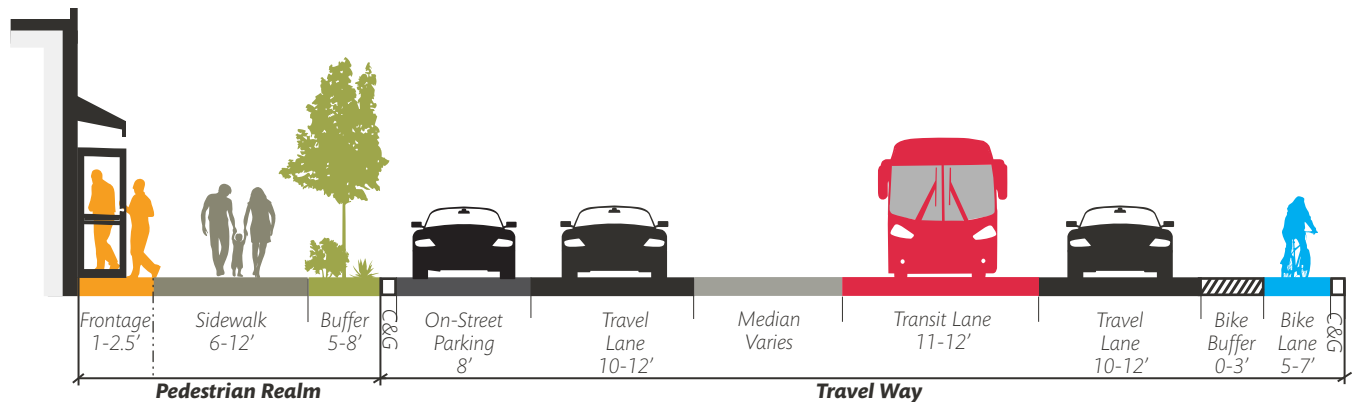
FIGURE 7.5.65 Mixed Use Area



### 7-5(E)(1)(iii) Pedestrian Facility Dimensions

1. See [TABLE 7.5.54](#) for design requirements for pedestrian facilities and other roadway elements by location and functional class. See [Part. 7-5\(J\) Local Streets](#) for additional guidance on pedestrian facilities on local roadways.
2. All sidewalks on new and reconstructed roadways shall provide a minimum 5-foot wide pedestrian access route.
3. Wider sidewalks shall be provided in Plan-designated Centers, along Transit, Multi-modal, and Main Street corridors, and locations with high-pedestrian activity levels per [TABLE 7.5.54](#).
4. If right-of-way is constrained and there is insufficient space for a landscaping buffer, the sidewalk should be widened an additional 2 feet. This extra width is used to provide additional pedestrian circulation and comfort, and to create separation from transit service running in curbside lanes, while also serving the various roles of the landscape/buffer zone.

FIGURE 7.5.66 Street Element Dimensions along Major Roads



**TABLE 7.5.54 Street element dimensions**

Corridor Type	Location	Design Speed (MPH)	Pedestrian Realm			Travel Way		
			Frontage Zone	Sidewalk Width	Landscape / Buffer Zone	Bike Lane Width*	Bike Buffer	Travel Lane Width***
Premium Transit	Inside Center	30-35	1-2.5'	10-12'	6-8'	6-6.5'	0-3'	10-12'
	Outside Center	35-40	1-2.5'	8-10'	6-8'	6-7'	1.5-3'	10-12'
Major Transit	Inside Center	30-35	1-2.5'	10-12'	6-8'	5-6.5'	0-3'	10-12'
	Outside Center	35-40	N/A	6-10'	6-8'	6-7'	1.5-3'	10-12'
Multi- Modal	Inside Center	30-35	1-2.5'	10-12'	6-8'	5-6.5'	0-3'	10-11'
	Outside Center	35-40	N/A	6-10'	6-8'	6-7'	1.5-3'	10-11'
Commuter	Inside Center	30-35	1-2.5'	10'	6-8'	5-6.5'	1.5-3'	10-12'
	Outside Center	40-50	N/A	6'	6-8'	6-7'	3-5'	10-12'
Main Street	Main Street	25-30	1-2.5'	10-12'	6-8'	5-6.5'	0-3'	10-11'
Other Arterial	Inside Center	30-35	1-2.5'	10'	6-8'	5-6.5'	0-3'	10-11'
	Outside Center	35-40	N/A	6'	5-6'	6-7'	1.5-3'	10-11'
Minor Arterial	Inside Center	30-35	1-2.5'	10'	6-8'	5-6.5'	0-3'	10-11'
	Outside Center	35-40	N/A	6'	5-6'	6-6.5'	1.5-3'	10-11'
Major Collector	Inside Center	25-30	1-2.5'	10'	5-6'	5'	0-3'	10-11'
	Outside Center	30-35	N/A	6'	5-6'	5-6'	0-3'	10-11'
Minor Collector	Inside Center	25-30	1-2.5'	10'	5-6'	5'	0-3'	10-11'
	Outside Center	30-35	N/A	6'	5-6'	5-6'	0-3'	10-11'
Major Local	Inside / Outside Center	18-30	1-2.5' / N/A	5'	5-6'	Shared Lane**		See Local Road Section
Other Locals	Inside / Outside Center	15-25	1-2.5' / N/A	5'	4-6'	N/A	N/A	

\* Not including the gutter pan.

\*\* Dedicated bicycle infrastructure may be appropriate along some Major Local roads. In these circumstances, use the design characteristics of a minor collector (inside center). See [Part. 7-5\(J\) Local Streets](#) for more information.

\*\*\* See [Part. 7-5\(G\) Public Transit](#) for additional guidance on travel lane widths for roads with transit service.

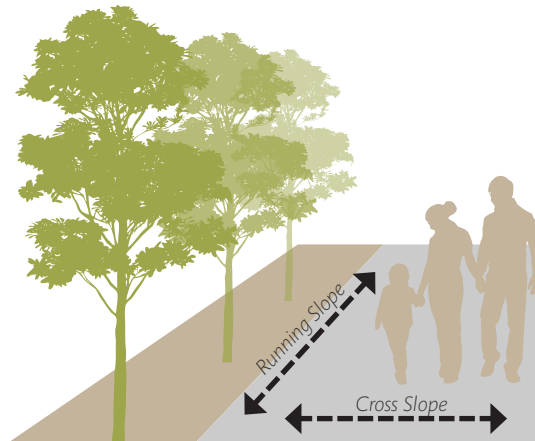
### 7-5(E)(1)(iv) Frontage Zone

1. A frontage zone is not required for development in residential and non-residential zone districts where large front setbacks apply.
2. The frontage zone is encouraged for development in mixed use zones, particularly in areas with setback maximums, with overhead awnings and signs projecting over the sidewalk, and in Downtown, Urban Centers, Premium Transit Corridors, and Main Streets, as designated by the Comprehensive Plan.

### 7-5(E)(1)(v) Sidewalk Design Requirements

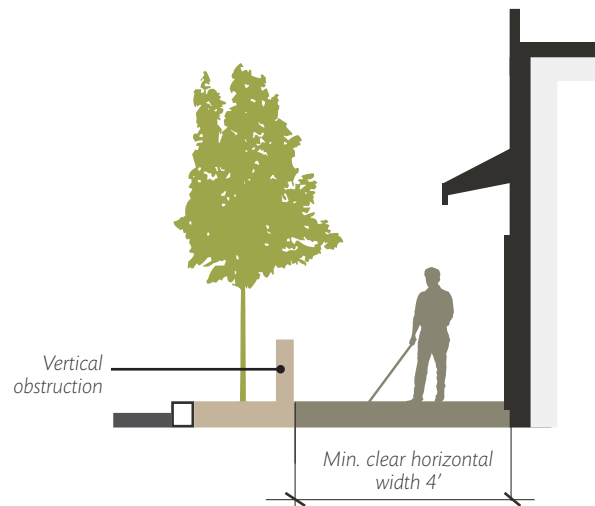
1. Sidewalks and curb ramps are to be a minimum 4" thick Portland cement concrete as shown in the Standard Details. Designs incorporating alternate materials must be approved by the Design Review Committee. The basis for consideration of such approval will be appropriateness, safety, and durability resulting in a useful life expectancy near or equal to that of the standard Portland cement concrete sidewalks.
2. All new sidewalks shall meet or exceed ADA/PROWAG requirements. Reconstruction projects including sidewalks and ramps shall be brought into conformity with ADA/PROWAG standards to the maximum extent possible.
3. Sidewalk cross slopes shall not exceed 2%. To ensure ADA/PROWAG compliance, it is recommended that cross slopes be designed at 1.5% to allow for tolerance in construction. See [FIGURE 7.5.66](#).
4. The sidewalk running slopes shall have a maximum grade of 5% unless the existing grade of the roadway exceeds 5%. In which case the sidewalk may match but not exceed the general grade established by the adjacent roadway or right-of-way easement. See [FIGURE 7.5.66](#).

**FIGURE 7.5.67 Sidewalk Slopes**



5. If it is necessary to locate objects such as mailboxes, hydrants, signposts, etc. within a sidewalk, then the sidewalk shall be widened to provide a minimum pedestrian access route of 4 feet around any part of the obstruction.

FIGURE 7.5.68 Pedestrian Access Route



6. If an object must protrude farther than 4 inches into a pedestrian access route at a height that is greater than 27 inches and less than 80 inches above the sidewalk surface, it must include a warning device that is detectable by a vision-impaired person who navigates with a cane. The minimum 4-foot pedestrian access route must still be provided around the object.

#### 7-5(E)(1)(vi) [Landscape/Buffer Zone Requirements](#)

1. See [TABLE 7.5.54](#) for required landscape/buffer zone widths.
2. Landscape/buffer zones are required for all new development.
3. Landscape/buffer zone surfacing may consist of planting areas or a walkable surface provided that it is visually distinct from the pedestrian access route.
4. It is strongly encouraged to include landscape/buffer zones in road reconstruction projects, especially along higher speed roadways, to improve pedestrian safety and comfort. Due to constrained right-of-way, buffers shall be provided as space permits. Where 2-foot width or less is available for the landscape/buffer zone, the sidewalk may be widened instead of providing the buffer.
5. Landscape/buffer zones are a high priority along corridors where transit operates.
6. In locations where there is insufficient right-of-way for landscape/buffer zone, street trees shall be located in accordance with the Street Tree Ordinance. The minimum pedestrian access route must be maintained at all times where street trees are provided.
7. For minimum planting area size, plant size, spacing, soil condition, installation, irrigation, and other general information applicable to planting in the public right-of-way, see [IDO Section 14-16-5-6\(C\), General Landscaping Standards](#).
8. For information about required street trees, their location, and tree well dimensions, see [IDO Section 14-16-5-6\(D\) Street Frontage and Frontage Landscaping](#) and the [Street Tree Ordinance \(6-6-2\)](#).
9. Landscape/buffer zones shall be designed and used per Low Impact Development (LID) guidelines as outlined in [Chapter 6](#).

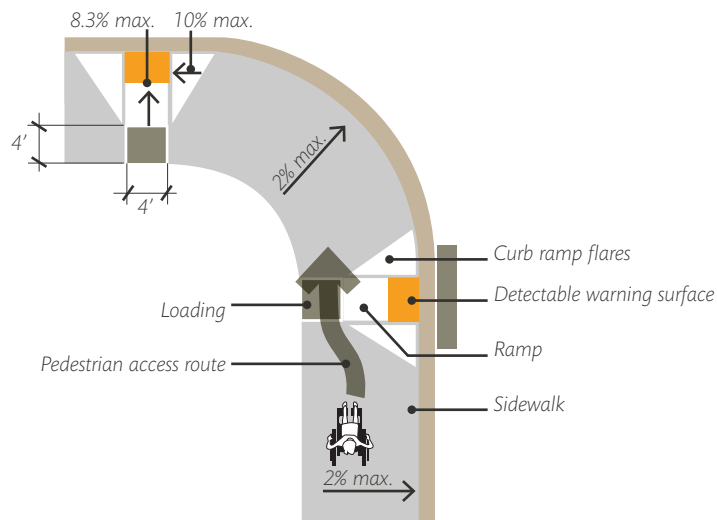


### 7-5(E)(1)(vii) Curb Ramp Requirements

1. All curb ramps shall meet or exceed ADA/PROWAG requirements.
2. Curb ramps are required to provide access between elevated pedestrian facilities and road surfaces at pedestrian crossings. Ramps shall be installed at all intersections unless pedestrian crossing is prohibited. For the purposes of this section, the following definitions apply:
  - a. **Intersection:** The location where two roadways (public or private) intersect.
  - b. **Intersection crosswalk:** The extension of a sidewalk or shoulder across an intersection, whether it is marked or not.
3. Curb ramps are categorized by their design and position relative to the pedestrian facility and roadway. See [FIGURE 7.5.69](#), [FIGURE 7.5.70](#), and [FIGURE 7.5.71](#) below for illustrative examples of common ramps.

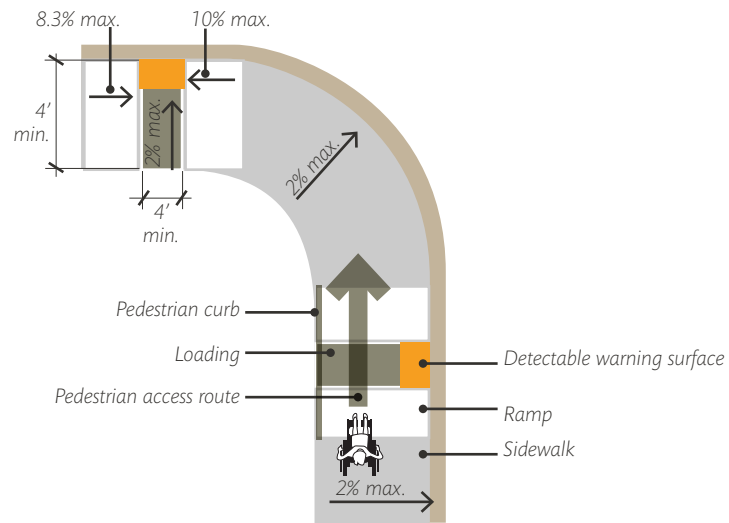
Perpendicular curb ramps shall have a running slope that cuts through or is built up to the gutter grade break at right angles.

**FIGURE 7.5.69 Perpendicular Curb Ramp**



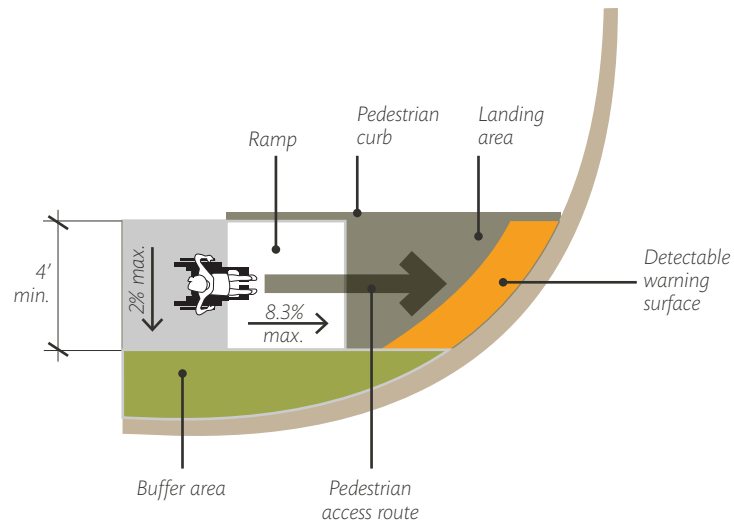
Parallel curb ramps shall have a ramp running slopes that are in-line with the direction of sidewalk travel.

FIGURE 7.5.70 Parallel Curb Ramp



Directional curb ramps shall have a running slope that is in-line with the direction of sidewalk travel.

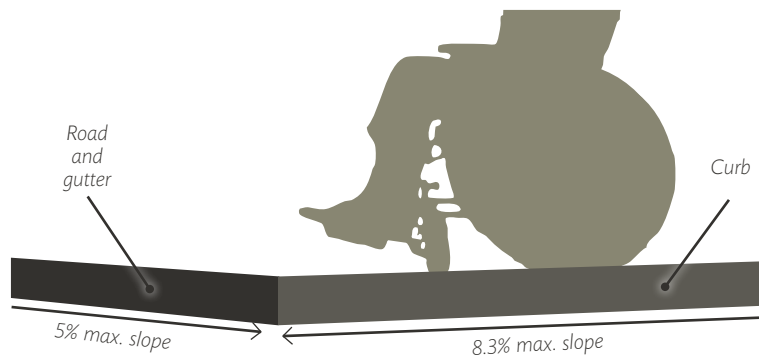
FIGURE 7.5.71 Directional Curb Ramp



4. Curb ramps shall be aligned to fall within the boundaries of crosswalks, marked or unmarked, so that pedestrians who have vision or mobility impairments are not directed outside the crosswalk or into a vehicle travel lane.
5. As much as possible, curb ramps shall be aligned in-line with the direction of pedestrian travel. ADA/PROWAG compliant ramps shall be wholly within the public right-of-way.
6. During reconstruction projects on collector and arterial roadways, parallel or perpendicular curb ramps shall replace diagonal ramps, where feasible. Ramps on the opposing side of the street shall be reconstructed to match newly installed parallel or perpendicular curb ramps.

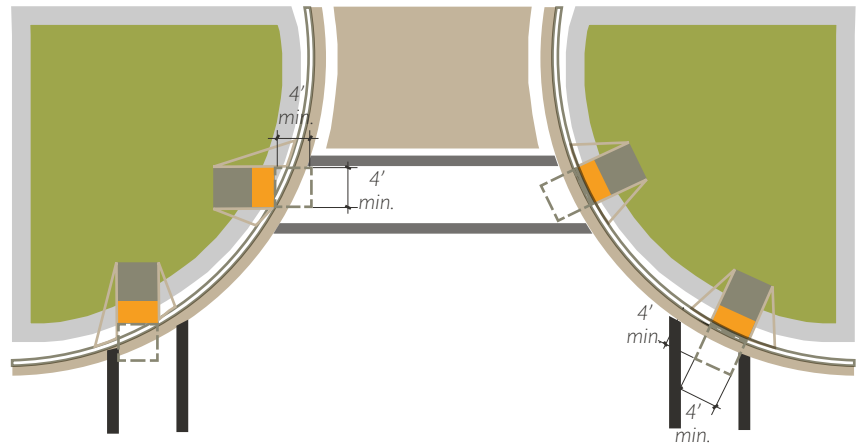
7. Diagonal curb ramps and blended transition ramps are generally discouraged in new construction projects. They may be acceptable at the intersections of major local and normal local roadways. See [Part. 7-5\(J\) Local Streets](#) for more information. All diagonal and blended transition ramps shall be ADA/PROWAG compliant.
8. Ramps for crossings at intersections shall be located as close to the intersection as practicable to make pedestrians more visible to turning vehicles.
9. The running slope of the curb ramp shall not exceed 8.3%. To ensure ADA/PROWAG compliance, it is recommended that the running slope be designed at a maximum of 7.5%. At the discretion of the City Engineer, exceptions may be necessary as part of road reconstruction projects where compliance is not feasible.
10. For connections to steep roadways the ramp does not need to exceed 15 feet in length. Refer to [PROWAG](#) for additional guidance.
11. The change in grade at the bottom of the curb ramp and adjoining road surface is typically 10% and shall not exceed 13.3%. The counter slope of the gutter or road at the-foot of a curb ramp is not to exceed 5.0%. See [FIGURE 7.5.72](#) for the maximum allowed counter slope.

**FIGURE 7.5.72 Curb Ramp Counter Slope**



12. The maximum cross slope of a curb ramp is 2%. To ensure ADA/PROWAG compliance, it is recommended that cross slopes be designed at 1.5%.
13. Ramps shall be as wide as the adjoining sidewalk to the greatest extent feasible. The minimum width of the ramp, excluding side flares, is 4 feet.
14. For parallel ramps, a level landing shall be provided at the bottom the ramp within the pedestrian access route. The landing length and width shall be at least 4 feet. The running and cross slopes of the landing shall not exceed 2%. To ensure ADA/PROWAG compliance, it is recommended that running and cross slope be designed at 1.5%.
15. For perpendicular ramps, a level landing shall be provided at the top the ramp within the pedestrian access route. The landing length and width shall be at least 4 feet. The running and cross slopes of the landing shall not exceed 2%. To ensure ADA/PROWAG compliance, it is recommended that running and cross slope be designed at 1.5%.
16. The running and cross slopes for mid-block crossings may match the grade of the roadway.
17. Beyond the bottom grade break where the ramp meets the roadway, a clear space of 4 feet by 4 feet shall be provided within the width of the pedestrian street crossing (marked or unmarked crosswalk) and wholly outside of the parallel vehicle travel lane.

FIGURE 7.5.73 Curb Ramp Clear Space



18. The maximum slope of the side flares between the curb ramp and the sidewalk is 10%, measured parallel to the gutter.
19. Ramps shall not be obstructed by hydrants, signposts, poles, utilities, or other vertical obstructions. Manhole, water meters, or valve covers may need to be adjusted to match the ramp slope.
20. Surface materials used for curb ramps shall be firm, stable and slip-resistant.
21. Curb ramps shall include a detectable warning surface (DWS), measuring 2 feet in the direction of travel and the full width of the ramp, excluding the flares. The DWS shall be placed at the back of the curb, but is not required to follow a curb radius.
22. DWS are required on all curb ramps located in the public right-of-way. They are required at driveway entrances that are wider than 24'.
23. Detectable warning surfaces shall contrast visually with the adjacent gutter, road or walkway surface, either light-on-dark or dark-on-light.

#### 7-5(E)(1)(viii) [Pedestrian Signal Devices](#)

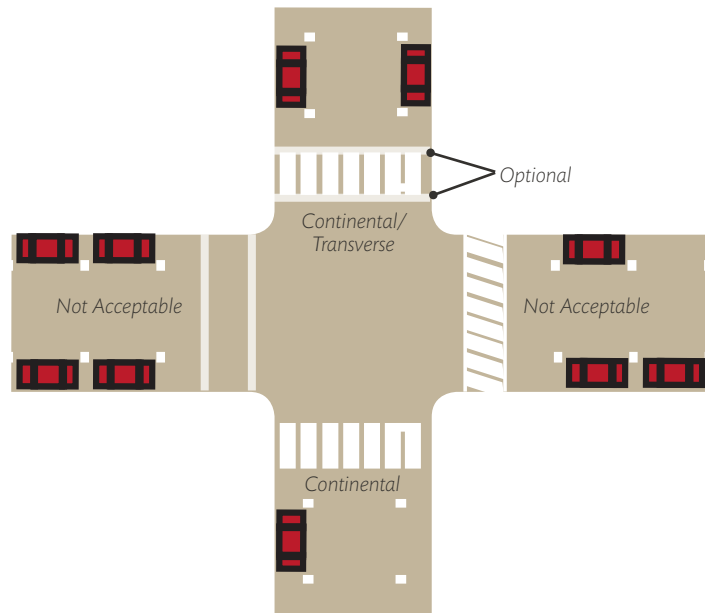
1. In accordance with PROWAG, all new or reconstructed pedestrian signal devices shall be installed to be accessible to pedestrians with vision or mobility impairments. Signal poles shall be located to not obstruct pedestrian movements.
2. Criteria for accessible pedestrian signals are provided in "Accessible Sidewalks and Street Crossings," published by the U.S. Department of Transportation, Federal Highway Administration.

#### 7-5(E)(1)(ix) [Crosswalk Design](#)

1. Crosswalks indicate to pedestrians where to cross a street. For more guidance on the appropriate locations for crosswalks, see [Section 7-5\(A\)\(7\)](#).
2. See [Part 7-5\(C\) Pavement Design](#) for guidance on appropriate materials to be utilized in the crosswalk.
3. The running slope and cross slope shall meet ADA/PROWAG requirements.
4. In Centers, the width of marked crosswalks should be at least 10 feet and should match the width of the sidewalk. In other areas, marked crosswalks should be no less than 6 feet wide.

5. Marked crosswalk lines should extend the full length of the crossing.
6. Curb extensions may be provided at crosswalks to reduce the crossing distance for pedestrians, depending on roadway conditions and appropriate curb return radius. See the [NACTO Urban Street Design Guide](#) or other accepted standards for additional guidance on curb extension design and appropriate situations for implementation.
7. See [FIGURE 7.5.74](#) for acceptable crosswalk marking designs. See the [MUTCD](#) and standard City drawings for guidance on pavement markings.

**FIGURE 7.5.74 Crosswalk Marking**

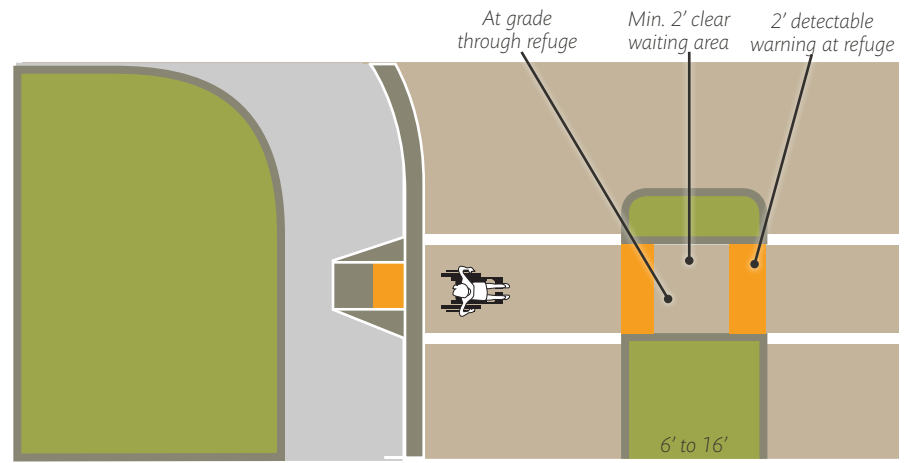


### 7-5(E)(1)(x) [Refuge Islands](#)

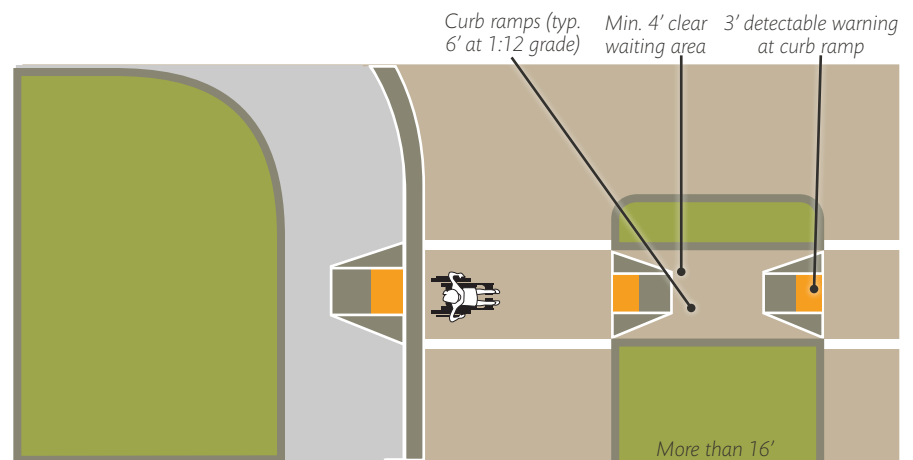
1. Median refuges or pedestrian safety islands (referred hereafter as “refuge islands”) are protected spaces in the center of the roads, and may be located at signalized or unsignalized intersections or at mid-block crossings. At unsignalized crossings median refuges enable bicyclists and pedestrians to safely cross a street halfway.
2. These features may be used in combination with other dedicated crossing elements, including marked crosswalks, signage, flash beacons, HAWK signals, and traffic signals. See the Designated Pedestrian Crossings discussion in [Article 7-5 Design Standards](#) for additional information.
3. Refuge islands are recommended for designated pedestrian crossings under the following circumstances, as right-of-way allows:
  - a. Where pedestrians must cross a total of three lanes or more
  - b. Designated bicycle routes
  - c. High pedestrian and/or bicycle volume crossings
  - d. Roads with speeds above 30 MPH and/or traffic volumes higher than 12,000 ADT that provide impediments to safe crossing movements
4. Refuge islands shall be a minimum of 6 feet wide, with a width of 8-10' preferred. If a minimum 6' wide median cannot be provided without conflicting with a pedestrian access route, the median shall be modified to eliminate the conflict.
5. A detectable warning surface is required for all median refuge islands.

6. Refuge islands should provide a clear 6' level waiting area within the median. Median refuge islands should have clear signage, pavement markings, curbs, and/or raised elements such as plantings or bollards to protect pedestrians waiting in the center of the roadway.
7. See [FIGURE 7.5.75](#) and [FIGURE 7.5.76](#) for examples of refuge islands.
8. Analysis of vehicle access should be considered as the presence of median refuge islands may result in restrictions to vehicle turn movements.
9. See the [NACTO Urban Street Design Guide](#) and the [NACTO Urban Bikeway Design Guide](#), or other acceptable design guidance documents, for additional information on the design and appropriateness of refuge islands.

**FIGURE 7.5.75 Refuge Island – At Grade**



**FIGURE 7.5.76 Refuge Island – Raised Median**



### Section. 7-5(E)(2) Pedestrian Walkways

1. All existing and proposed development shall provide safe, direct, and convenient pedestrian access routes (referred to as a pedestrian walkway) connecting main entrances of buildings, establishments, or uses on a site that allow for public access, with all other such entrances and with available access points. This includes, but is not limited to parking sites, passen-

- ger loading zones, streets, sidewalks, and transit stops. On-site walkways shall also be provided to any abutting public park, trail, Major Open Space, or other civic or institutional use.
2. Per the IDO the following uses are exempt from the above requirement:
    - a. Single- or two-family dwelling units
    - b. Agricultural use
    - c. Open space
    - d. Cemetery
    - e. Wireless Telecommunication Facility
    - f. Off-premise sign
    - g. Minor utilities
    - h. Other uses not containing a principal building on the premise (with the exception of a parking facility)
  3. Pedestrian access on proposed developments shall consist of 6-foot wide accessible, direct, clearly discernible, and ADA/PROWAG-compliant walkway or multi-use path from the public right-of-way to main entrances.
  4. Commercial or multi-family developments requiring 5 or fewer parking spaces shall provide a minimum 4-foot walkway.
  5. Pedestrian walkways between buildings as required in the [IDO Section 5-3\(D\)\(3\). On-site Pedestrian Connections](#) shall have a minimum width of 5 feet.
  6. Pedestrian walkways located on private property shall be constructed of concrete, asphalt, or other firm, stable, and slip-resistant material as approved by the City Engineer.
  7. Pedestrian walkways that connect to the public rights-of-way shall be physically separated from vehicular surface areas, except where required to cross a drive aisle; such crossings shall be perpendicular wherever practicable.
  8. Private walkways shall be required in areas served by any street. Private walkways shall provide general pedestrian access within the development served and shall connect with all public sidewalks, public streets, parks, and open space. Each block, or each building in the case of multi-unit living, shall be served by a connection to the pedestrian access system.
  9. Private access that connects to the public roadway system and that are designed for travel speeds of 10 MPH or below may allow for pedestrians, bicyclists, and /or vehicles to share the same right-of-way, rather than providing discrete space for each user as approved by the City Engineer.

## **Part. 7-5(F) Bikeways and Trails**

### **Section. 7-5(F)(1) General Provisions**

1. Guidance for the development of bikeways is rapidly evolving with new designs being explored, tested, and incorporated into national guidance. This section builds upon guidance provided by national design manuals and identifies locally-preferred standards and procedures.
2. For additional detail and guidance, refer to the latest version of the following guides: the [AASHTO Guide for the Development of Bicycle Facilities](#), the [NACTO Urban Bikeway Design Guide](#), the [Manual on Uniform Traffic Control Devices \(MUTCD\)](#), and the [City of Albuquerque Bikeways & Trails Facility Plan \(BTFFP\)](#).
3. See NACTO or AASHTO for guidance on pavement markings intended to improve the visibility of bicycle lanes, striping of lanes and buffers, includ-



ing use of dashed lines to mark driveway access points, traffic merging areas, and transit stops.

4. See the MUTCD for standards related to bike lane symbols, pavement markings, and signage.
5. High bicycle-activity areas include facilities approaching and within a Comprehensive Plan designated Centers, premium transit station areas, and schools. Other high activity areas include neighborhoods with an average residential density of 10 units per acre or more.

### **Section. 7-5(F)(2) Locations of Future Facilities**

1. The location of future bikeways and trails is shown on both the [Metropolitan Transportation Plan's Long Range Bikeway System \(LRBS\)](#) and the BTFP. These future system maps show the facilities necessary to provide an integrated bikeway and trail network. The most recently updated future system map, either in the BTFP or the LRBS, shall be used to require planned bikeways and trails as part of new development.
2. New bicycle infrastructure should be considered as part of all reconstruction and new roadway projects.
3. In locations not identified on the LRBS or BTFP maps, bikeways and/or trails may be required if they connect or close a gap in the existing system.

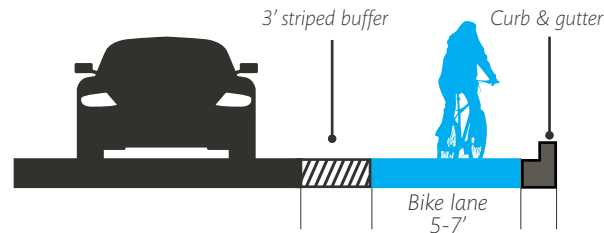
### **Section. 7-5(F)(3) Bicycle Lanes**

#### **7-5(F)(3)(i) [Definition and Appropriateness](#)**

1. A bicycle lane is a lane on the roadway that has been designated by striping and pavement markings for preferential or exclusive use by bicyclists.
2. Bicycle buffers are the physical space that separates bicyclists from motorists. Buffers may consist of pavement markings or some form of vertical separation. See [7-5\(F\)\(3\)\(iii\)](#) for additional guidance on separated bicycle lanes with vertical barriers. See the [NACTO Urban Bikeway Design Guide](#) for guidance on bicycle buffer design options.
3. Bicycle buffers are appropriate on streets with higher speeds and traffic volumes, and/or as right-of-way allows.
4. Bicycle lanes are not required on local streets with speeds of 25 mph or less, low traffic volumes, narrow right-of-way, or that provide access to single-family residences; on these streets cyclists should share lanes with vehicle travel. Common treatments to facilitate shared lanes include signage, pavement markings, and bike route and bicycle boulevard designations.
5. Bicycle lanes should be provided on all new collector roadways and evaluated on all new arterial roadways.
6. The addition of bicycle lanes as part of restriping, resurfacing, and rehabilitation projects on existing arterial and collector roadways must be evaluated, after reviewing network connectivity, and in accordance with the [City Complete Streets Ordinance](#).
7. Consult the [Priority Street Element Matrix](#) of the Comprehensive Plan for level of appropriateness of bicycle lanes and buffers on Comprehensive Plan-designated Corridors.
8. Bicycle lanes may be implemented on existing roadways by reducing automobile travel lane and median widths, reducing the number of travel lanes, and/or reconsidering the need for parking. If reconstructed bike lanes

cannot meet the requirements of this section, the bicycle lanes should be installed to meet minimum national guidance recommendations.

FIGURE 7.5.77 Bike Lane



### 7-5(F)(3)(ii) [Design Considerations](#)

1. Bicycle lane and buffer widths are provided in [TABLE 7.5.54](#). Wider bicycle lanes and/or striped buffers are desirable on higher speed roadways (i.e. 35 MPH or greater). Following the Comprehensive Plan's Priority Street Element Matrix, wider widths for bike lanes and bike buffers should be included on corridors where bike lanes are a priority.
2. Bike lanes narrower than those shown in [TABLE 7.5.54](#) may be considered where bike lanes are desirable but available right-of-way is insufficient. In constrained right-of-way situations, the widths of bicycle lanes, general purpose travel lanes, and medians shall meet minimum national guidance recommendations.
3. Bicycle lane is measured from the centerline of the painted edgeline to the edge of asphalt pavement. Lane width does not include the gutter pan.
4. Bicycle lanes shall be constructed or reconstructed level and flush with roadside gutter pans with no more than 5/8-inch vertical difference.
5. Bicycle lanes shall be constructed to avoid hazardous conditions that might force awkward or unsafe bicycle movements. Storm drainage and other utilities shall be designed and located to minimize impact.
6. Improvements to intersections with bicycle lanes, shall include bicycle-sensitive signal actuation where feasible. See [NACTO Urban Bikeway Design Guide](#) for marking detection area and detection operations.
7. The dropping of bicycle lanes at intersections is strongly discouraged. Where feasible, roadway designs shall incorporate bicycle treatments at intersections to reduce conflicts between cyclists and motorists. Options include bike boxes, intersection crossing markings, median refuge islands, dashed lines at the entrance to right turn lanes, and the use of sharrows for shared bicycle lane and right turn only lanes. See [NACTO Urban Bikeway Design Guide](#), or other approved design manual, for additional guidance.
8. Where on-street parallel parking is present and bicycle lanes are located to the left of automobile parking, a minimum combined width of 13 feet is required, with a recommended 7-foot-wide parallel parking stall and a 6-foot-wide bike lane. The gutter pan may be included in the parking stall width.
9. Vertical delineators at intersections should be considered in situations where the bike lane is used as a turning bay for vehicles.

### 7-5(F)(3)(iii) [Separated Bicycle Lane Design](#)

1. Separated bicycle lanes, also called protected bicycle lanes or cycle tracks, include some form of vertical element to separate the bicycle lane from

- automobile travel lanes. The vertical element may include tubular markers, moveable planters, raised curb, or vehicle parking.
2. Separated bicycle lanes may be located at the street level, raised to an intermediate level between the roadway and the sidewalk, or at the same level as the sidewalks.
  3. Separated bicycle lanes at the sidewalk level should have some form of buffer or visual means of differentiating between the bicycle lane and the sidewalk. See the [NACTO Urban Bikeway Design Guide](#) for additional information on raised bicycle lanes at intermediate levels.
  4. Separated bicycle lanes are most appropriate along roadways with higher travel speeds and for connections between and within Comprehensive Plan-designated Centers.
  5. General recommended separated bicycle lane dimensions involve a 6.5-foot lane and a 3-foot buffer. The ranges provided in [TABLE 7.5.54](#) allow sufficient flexibility for striped buffered bicycle lanes or cycle tracks to be implemented within the recommended dimensions.
  6. Two-way cycle tracks are discouraged. See [NACTO Urban Bikeway Design Guide](#) for separated bicycle lane/cycle track design guidance.

### **Section. 7-5(F)(4) Bicycle Routes**

1. Bicycle routes are designated roadways in which cyclists share roadway space with motorists. There is no designated infrastructure, though bicycle routes should have appropriate directional and informational signing.
2. Bicycle routes are most appropriate on low-volume (i.e. below 3,000 average daily traffic), low-speed roadways (i.e. posted speeds of 25 MPH or below). Bicycle routes may feature some traffic calming elements, and may be marked with sharrow.
3. Bicycle route designations may be an appropriate option for existing roadways with constrained rights-of-way and where existing bicycle lanes do not meet the minimum design standards. This option is only appropriate on roads with low average travel speeds and preferably with low traffic volumes.
4. The sign "Bicycles May Use Full Lane," or alternate as approved by the City Engineer, is the preferred signage to indicate shared-lane facilities. Sharrow lane markings also improve the visibility of cyclists on a shared roadway.
5. See [NACTO Urban Bikeway Design Guide](#) and [AASHTO Guide for the Development of Bicycle Facilities](#) for further guidance including guidance on wayfinding and shared lane markings.

### **Section. 7-5(F)(5) Bicycle Boulevards**

1. Bicycle boulevards are enhanced bicycle routes designed to encourage the through-movement of bicycles while maintaining local access for motor vehicle travel.
2. Bicycle boulevards are most appropriate on low-volume (i.e. below 3,000 vehicles per day), low-speed roadways (i.e. posted speed of 25 MPH or below) with direct access to destinations. Ideally they should be at least two miles long. Bicycle boulevards may be parallel to roadways with bicycle lanes to provide lower-stress alternative routes.
3. Traffic calming devices are used to control motor vehicle speeds and discourage through-vehicle trips. These devices may include diverters, speed humps, traffic circles, or planters that allow through-access by bicycles only. See [Part. 7-5\(L\) Traffic Calming](#) for additional information.

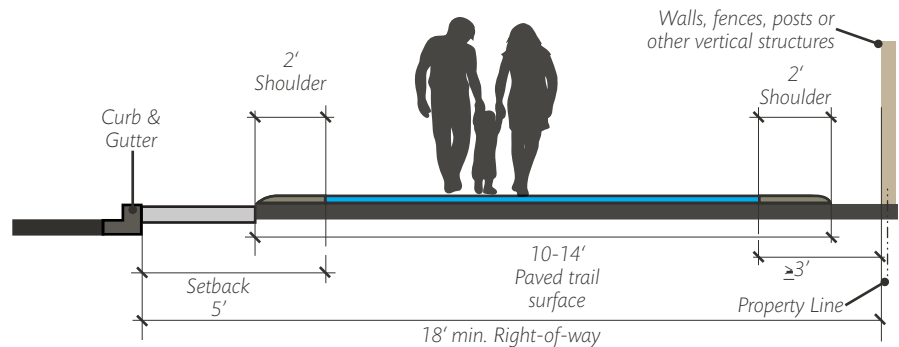
4. If an existing roadway is designated as a bicycle boulevard, signal timing and stop control should be evaluated to prioritize bicycle movements.
5. See the BTFP Design Guidelines Section 7(C)(6), Bicycle Boulevards for more detail and design guidance for Bicycle Boulevards.

### Section. 7-5(F)(6) Paved Trails

#### 7-5(F)(6)(i) Definition and Appropriateness

1. Paved trails, also called multi-use trails or shared-use paths, are facilities that are dedicated for pedestrians and cyclists and are designed for use by people of all abilities for transportation and recreational purposes.
2. Trails are physically separated from vehicular traffic and are either within the roadway right-of-way or within an easement.
3. Consult the *BTFP* and the *LRBS* for future trail locations.

FIGURE 7.5.78 Paved Trail



#### 7-5(F)(6)(ii) Design Standards

1. The minimum trail width shall be 10 feet excluding shoulders. The preferred trail width is 12 feet, with 14 feet desired for high-use areas and long distance routes, as defined in the LRBS.
2. Trails less than 10 feet wide need an exception by the City Engineer and shall require a separate legal "Trail Maintenance Agreement".
3. The minimum amount of space required for a trail along a roadway is 18 feet. This allows for 5 feet setback from curb, 10 feet trail width, and 3 feet from property line. The setbacks from the curb and the property line may include the shoulders (see *FIGURE 7.5.78*).
4. Whenever possible, easements for trails shall be configured so that a clear field of view for the trail user is provided from each end of the trail.
5. A minimum 2-foot shoulder adjacent to both sides of the trail is required to be constructed of compacted base course, subgrade, or crusher fines, with cross-slopes of no more than 2%.
6. A minimum 3-foot buffer is required between the private property line or any vertical structures and the trail, which may include the compacted shoulder.
7. Trail cross slope shall not exceed 2% unless approved by the City Engineer. To ensure ADA/PROWAG compliance, it is recommended that cross-slopes be designed for a maximum of 1.5% to allow for tolerance in construction.

Trail design should carefully consider compound slopes when there is both a cross slope and running slope. See [Part. 7-5\(E\) Pedestrian Facilities](#) for slope definitions and requirements.

8. Follow [AASHTO Guide for the Development of Bicycle Facilities](#) for protection requirements for trails next to steep slopes.
9. Permeable pavement may be utilized to address drainage and storm water run-off issues with approval by the City Engineer. Different pavement materials or colors may also be used to fit in with the natural context in locations near major public open spaces.

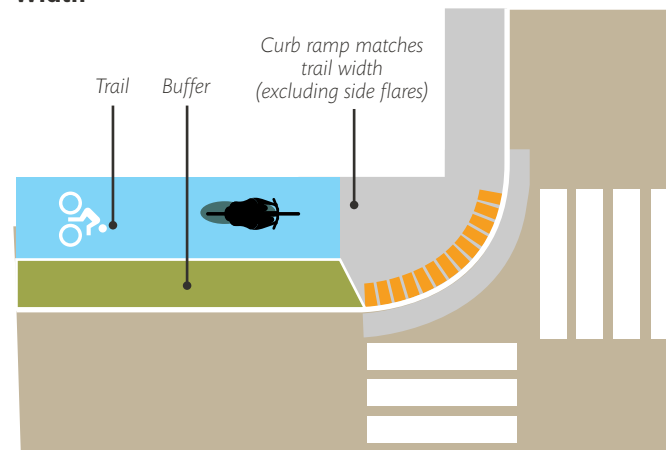
### 7-5(F)(6)(iii) [Trail Running Slope](#)

1. To the greatest extent feasible the trail running slope shall have a maximum grade of 5%. In constrained conditions, the trail may match but not exceed the general grade established by the adjacent roadway or right-of-way easement.
2. Landings and rest areas shall be provided on extended grades to allow users to stop and rest, particularly for steep trails and high-use trails. The landings should be located outside the trail through lanes. See [PROWAG](#) for guidance on the frequency of landing areas.
3. Advance warning signs shall be used to identify trail locations with slopes that greatly exceed ADA guidelines, due to the slope of the road or other unavoidable topographic constraints.

### 7-5(F)(6)(iv) [Curb Ramps](#)

1. Curb Ramps are required to provide access between elevated trails and road surfaces. See the Curb Ramp Requirements element of [Part. 7-5\(E\) Pedestrian Facilities](#) for additional guidance.
2. For trails, ramp width should match the trail width, excluding side flares ([FIGURE 7.5.79](#)). At no point should the access way or ramp be narrower than 10 feet at intersections where a trail is present. Ramps should be free of vertical obstructions.
3. Access ramps shall have a maximum running slope of 8.3%.
4. A slip ramp may be used to connect an on-street bike facility to an off-street bike facility.

**FIGURE 7.5.79 Blended Transition Ramp with Matching Trail and Ramp Width**



### 7-5(F)(6)(v) [Equestrian Accommodations](#)

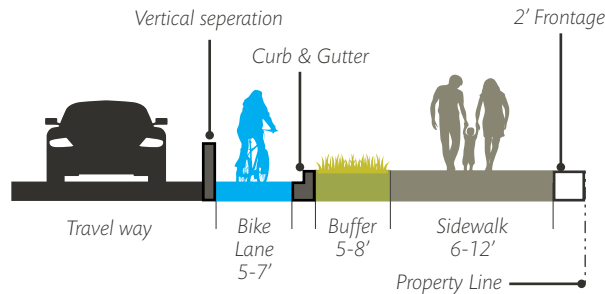
Follow the [BTFP](#) guidance for equestrian accommodations for trail and bridge design where there is known equestrian use and facilities near Open Space.

### Section. 7-5(F)(7) Trail Alternatives

Where future trails and bicycle lanes are shown in combination on the BTFP or LRBS, two alternative designs may be pursued, with approval of the City Engineer.

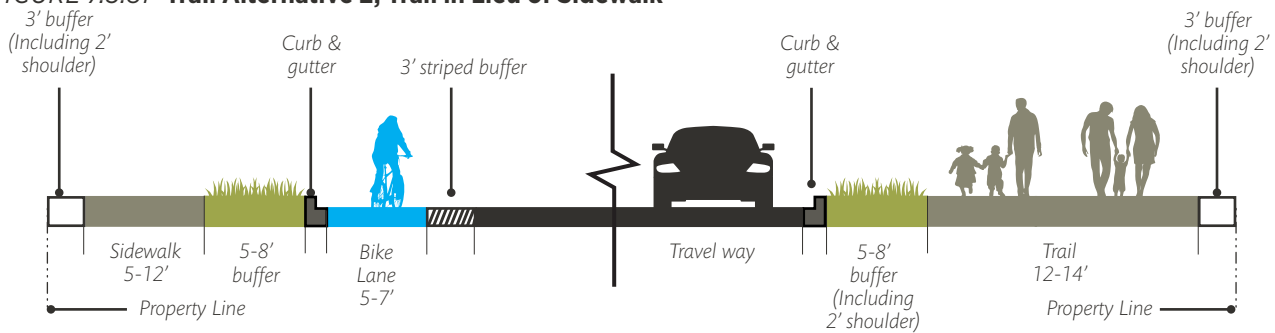
1. A sidewalk combined with one-way separated bike lanes. Sidewalk design for this alternative shall follow requirements specified in [Part. 7-5\(E\) Pedestrian Facilities](#). The one-way separated bikeway shall follow the [NACTO Urban Bikeway Design Guide](#), in conjunction with other national guidance.

FIGURE 7.5.80 Trail Alternative 1, Vertical Separation



2. A trail may be constructed in lieu of a sidewalk on one side of the street, with a sidewalk on the opposite side of the street (see [FIGURE 7.5.80](#)). The trail must meet recommended trail width dimensions (10-14 feet) and recommended landscape buffer from [TABLE 7.5.54](#).

FIGURE 7.5.81 Trail Alternative 2, Trail in Lieu of Sidewalk



## Part. 7-5(G) Public Transit

### Section. 7-5(G)(1) General Provisions

1. The provisions of this section describe appropriate transit stop facilities by location and the layout of stop area features. Other considerations in this section include roadway design issues that should be addressed during

- reconstruction projects, as well as guidance for dedicated transit infrastructure.
2. Site development applications and City roadway projects may be reviewed by ABQ RIDE and/or Rio Metro Regional Transit District (RTD) for the provision of transit stop amenities, where applicable. Contributions to transit stop amenities may be asked of a site developer as a mitigation measure. See the [Scoping Report](#) and [Article 7-6 Traffic Studies](#) on mitigation measures for additional guidance.
  3. Guidance for this section is derived from the sources listed below. Updated versions of these documents or equivalent sources may be utilized with the approval of the City Engineer and the affected transit provider.
    - a. [U.S. Access Board's draft Public Rights of Way Accessibility Guide \(PROW-AG, 2013 version\)](#).
    - b. [NACTO Transit Street Design Guide \(2016 version\)](#)
    - c. [AASHTO Guide for the Geometric Design of Transit Facilities on Highways and Streets \(2014 version\)](#)
    - d. [American Public Transportation Association Designing Bus Rapid Transit Running Ways, 2010](#)
    - e. [TCRP Report 90 Bus Rapid Transit Volume 2: Implementation Guidelines, 2003](#)

### **Section. 7-5(G)(2) Pedestrian Connections to Transit Stops**

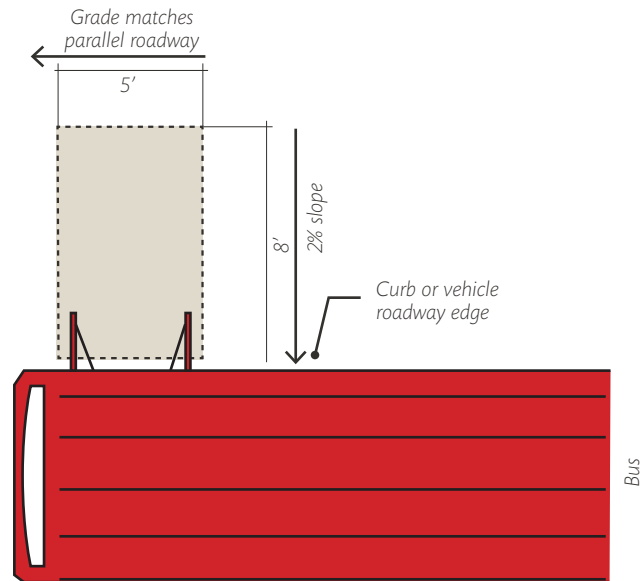
1. Per [IDO Section 14-16-5-3\(D\)\(3\)\(b\)](#), all non-residential, mixed use, and multi-family developments adjacent to transit stops, stations, and park and ride facilities must provide pedestrian connections.
2. See [Article 7-5 Design Standards](#) for additional guidance on pedestrian crossings.
3. Per the [Priority Street Elements Matrix](#) of the Comprehensive Plan, sidewalks wider than the minimum standards shown in [Table 1-1](#) are a high priority along Premium Transit and Major Transit corridors.

### **Section. 7-5(G)(3) Boarding and Alighting Areas**

1. At least one boarding area shall be provided at each stop or station. At high-volume stops a similar area should be provided for the rear door(s) as well.
2. The boarding and alighting area shall be a clear space that is at least 5 feet wide in the direction parallel to the roadway and 8 feet wide in the direction perpendicular to the roadway (see [FIGURE 7.5.82](#)).

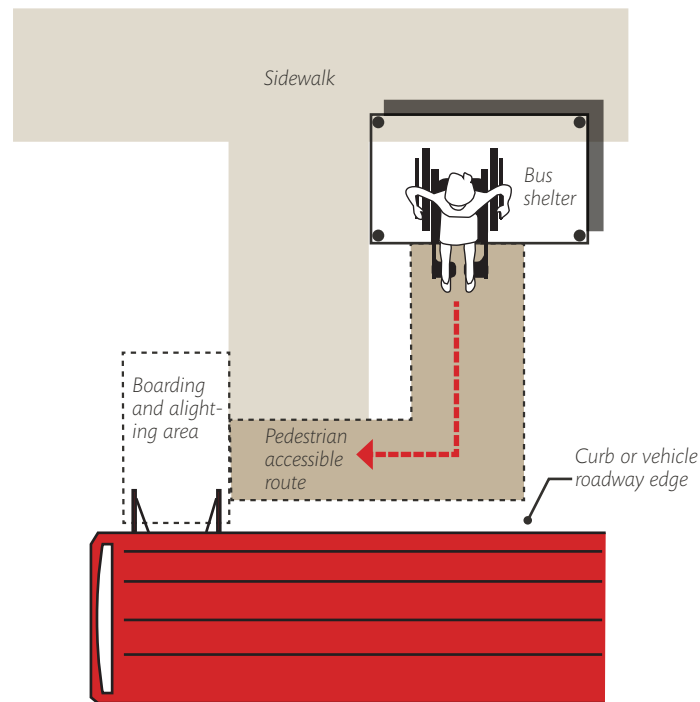


FIGURE 7.5.82 Transit Boarding and Alighting



3. The slope of the boarding and alighting area shall match the roadway grade in the direction parallel to the roadway. The grade perpendicular to the roadway shall be no more than 2%.
4. The boarding and alighting area must be firm, stable, and slip-resistant.
5. The boarding and alighting area shall be connected to sidewalks, private pedestrian walkways, existing bus shelters, and roads by an ADA/PROWAG-compliant pedestrian access route (see [FIGURE 7.5.83](#)).

FIGURE 7.5.83 ADA/PROWAG-Compliant Pedestrian Access Route



6. All curbside bus stops shall be designed to accommodate at least one bus serving the boarding and alighting area. The length of the bus queueing space depends on the type of vehicle(s) expected to serve the route. If there are multiple routes and thus multiple buses serving the stop, the queueing space should be extended accordingly. Potential transit service expansion and future routes should also be considered.

### **Section. 7-5(G)(4) Transit Stop Types**

The following contains guidance on transit stop types and desired amenities by location. It is expected that transit stops be integrated into the pedestrian realm. Additional right-of-way or easements may be required to implement desired amenities along existing roadways.

See [Part. 7-5\(E\) Pedestrian Facilities](#) for additional guidance on sidewalk widths. Per the Access and Connectivity chapter of the [IDO Section 14-16-5-3](#), there shall be pedestrian connections from adjacent developments to transit stops and stations.

#### **7-5(G)(4)(i) [Basic Transit Stop](#)**

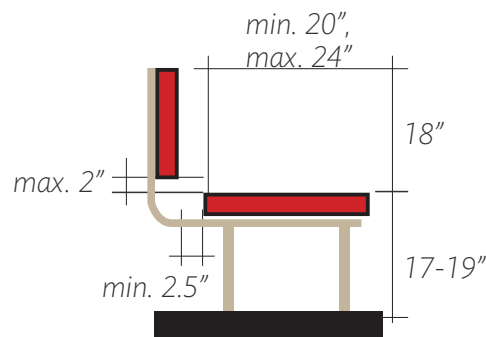
1. A basic transit stop consists of an accessible boarding and alighting area with easily identifiable signage indicating the location of the stop. Basic transit stops are most commonly associated with bus transit.
2. Basic stops are the minimum required transit stop infrastructure and are generally acceptable at locations where there are no more than two buses per weekday peak hour arriving at the stop. Basic transit stops do not feature benches or shelters.
3. Transit stops should be located near marked or protected pedestrian crossings, where possible.
  - a. A minimum of 10 feet of distance should be provided ahead of the transit vehicle at near-side stops.
  - b. At least 10 feet of distance should be provided behind the vehicle to the crosswalk at far-side stops, with a distance of 35 to 50 feet preferable.

#### **7-5(G)(4)(ii) [Transit Stop with Bench](#)**

1. A bench should be provided at transit stops on Major Transit corridors, locations where there are at least two buses per hour in the peak period arriving at the stop, or where considered appropriate by ABQ RIDE and/or the Rio Metro RTD.
2. The bench must be located so that it does not block the clear sidewalk width, preferably with the sidewalk routed between the bench and the curb.
3. The front of the bench should not be placed closer than 4 feet from the back of the curb, or 6 feet from the back of the curb when a travel lane exists immediately adjacent to the curb.
4. Benches should be oriented toward the street or the direction of the approaching transit vehicle.
5. The bench site area should include pedestrian access route connections (minimum 4 feet wide) to the sidewalk and the boarding and alighting area.
6. The bench site should include a level 30" by 48" maneuvering space adjacent to the bench that is firm, stable, and slip-resistant.

7. ADA/PROWAG-compliant bench design requirements are shown in [FIGURE 7.5.84](#) and listed below:
  - a. Seat length: 42 inches minimum
  - b. Seat height: 17-19 inches
  - c. Seat depth: 20 inches minimum, 24 inches maximum
  - d. Seat back, top: 18 inches minimum above the seat
  - e. Seat back bottom: 2.0 inches maximum above the seat
  - f. Separation between the seating surface and the seat back should be a minimum of 2.5 inches.
  - g. The wall of a shelter may serve as the seat back.

**FIGURE 7.5.84 ADA/PROWAG- Compliant Bench Design Requirements**



### 7-5(G)(4)(iii) [Transit Stop with Shelter](#)

1. A shelter should be provided, where feasible, at the following transit stop locations:
  - a. Along Major Transit corridors
  - b. Locations where there are at least three total buses per hour in the peak hour
  - c. Within Comprehensive Plan-designated Centers
  - d. Where considered appropriate by ABQ RIDE and/or the Rio Metro RTD
2. The shelter must be located so that it does not block the clear sidewalk width.
3. Shelters should not be placed closer than 4 feet from the leading edge of the roof of the shelter to the face of the curb. Where feasible 6 feet is desired.
4. Shelters shall be oriented toward the street or the direction of the approaching transit vehicle.
5. The shelter site area shall include ADA-compliant pedestrian access route connections (minimum 4 feet wide) to the sidewalk and to the boarding and alighting area.
6. Shelters should include space to rest, such as a bench or leaning rail.
7. Shelters shall have a minimum clear floor space of 4 feet by 4 feet for wheelchair users. The clear space shall be located under the shelter roof adjacent to any seating areas and not in front of or behind the seating area.
8. Any protruding objects in the shelter shall comply with ADA requirements.
9. The shelter must be located so that it does not block the clear sight distance requirements in [Section. 7-5\(I\)\(5\)](#).

### 7-5(G)(4)(iv) [Transit Station](#)

1. Usually associated with a premium service such as Bus Rapid Transit, transit stations are distinguished from transit stops by having level-boarding platforms and passenger amenities such as ticket vending machines and real-time transit information, as well as common transit stop amenities such as seating, shelters, and/or leaning rails.
2. Transit stations are most appropriate along Premium Transit corridors.
3. Transit stations may be located curbside or in the median. If a station is located in the median, marked or protected pedestrian crossings must be provided to the sidewalks on either side of the street.
4. Pedestrian crossings shall be provided directly to or within 100' of the transit station. See [Article 7-5 Design Standards](#) for additional guidance on pedestrian crossings.
5. See [NACTO Transit Street Design Guide](#) or other documents considered appropriate by ABQ RIDE and/or Rio Metro RTD for guidance on transit station design.

### 7-5(G)(4)(v) [Park and Ride Facilities](#)

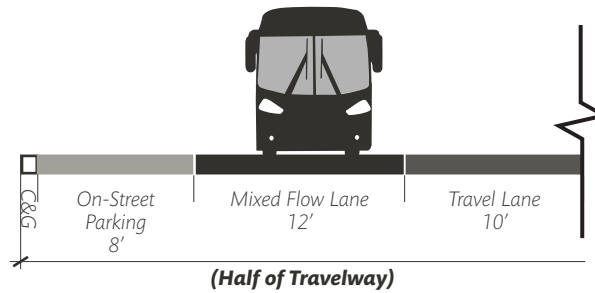
1. Parking lots or formal station facilities that allow commuters and other transit users to leave their vehicles and transfer to public transit vehicles. Park and ride facilities generally serve as transfer facilities for multiple routes. Park and rides should include space for picking up and dropping off passengers, bicycle racks, traveler information, shelters, and other station amenities.
2. Design for park and ride facilities is based on the available parcel or lot size and should follow general site development standards outlined in the DPM, including on-site circulation requirements and guidelines for pedestrian access from surrounding roads to boarding and alighting areas.
3. See [Part. 7-5\(B\) Site Access Points](#) for guidance on vehicle access to park and ride facilities.
4. Pedestrian access should be provided from developments at sites adjacent to park and ride facilities.

## **Section. 7-5(G)(5) Roadway Design Considerations for Transit in Mixed Flow Traffic**

### 7-5(G)(5)(i) [Travel Lanes](#)

1. Where transit operates in mixed flow traffic – generally the outside lane – widths at the higher end of the ranges provided in [TABLE 7.5.54](#) in the Street Elements section may be appropriate. Narrow lanes (i.e., at the low end of the range provided in Table 1-1 in the Street Elements section) may be provided for other lanes along the same corridor where transit does not operate).
2. Where transit operates adjacent to on-street parking, 12' travel lanes and 8' wide on-street parking spaces are preferred, though narrower widths may be considered under constrained circumstances (see [FIGURE 7.5.85](#)).
3. The buffer/landscape zone also serves to separate transit vehicles from pedestrians, utilities, and other elements in the Pedestrian Realm. See [Part. 7-5\(E\) Pedestrian Facilities](#) for additional guidance on sidewalk dimensions and buffers along the corridors where transit operates.

FIGURE 7.5.85 Travel Lane



### 7-5(G)(5)(ii) [Bus Turnouts and Bus Bays](#)

1. Additional right-of-way may be required for bus turnouts and bus bays on arterial and collector streets at locations determined by the City Engineer. The width of the additional right-of-way will be whatever is necessary to provide 10' from face of the curb along the bus bay, plus the additional area for a shelter. The length of the bus bay depends on the length of the vehicle(s) serving the route.
2. Dedication of right-of-way for transit amenities (e.g., bus bay, shelter, and sidewalk) may be required as a condition of approval for site plans. An easement for these purposes is satisfactory provided platting is not otherwise occurring on the property. Bus bay design must provide for conveyance of nuisance drainage flow by valley gutter or other approved means.
3. Bus turnouts consist of a dedicated zone on the side of a roadway for passenger boarding and alighting that prevents travel lanes from being blocked when buses stop to pick up and drop off passengers (See [FIGURE 7.5.86](#)).
4. Bus turnouts may be utilized where sufficient space exists on the side of the road to allow a transit vehicle to fully exit the travel lane. Bus turnouts require zones for deceleration, stopping, and accelerating to ensure transit vehicles can safely enter and exit the turnout, and may require the restriction of on-street parking to provide acceleration and deceleration zones.
5. Bus bays are similar to bus turnouts in that they provide a dedicated space for passenger boarding and alighting at the side of a road. In contrast to turnouts, bus bays have a protected zone with entrance and exit tapers. Bus bays require setbacks to enable the transit vehicle to completely exit the travel lane (see [FIGURE 7.5.87](#)).
6. Bus bays are most appropriate along corridors where the speed limit is 40 MPH or greater, or locations where maintaining efficient vehicle throughput is a high priority. Bus bays may be suitable in other situations.
7. Required locations for bus bays shall be determined by ABQ RIDE and/or the Rio Metro RTD and the City Engineer.
8. See the City Standard Drawings for bus bay dimensions.

FIGURE 7.5.86 Bus Turnout

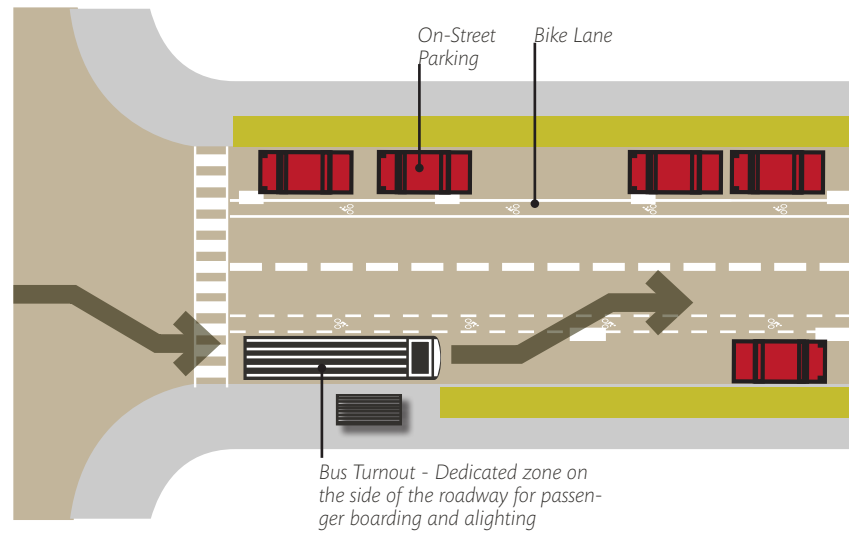
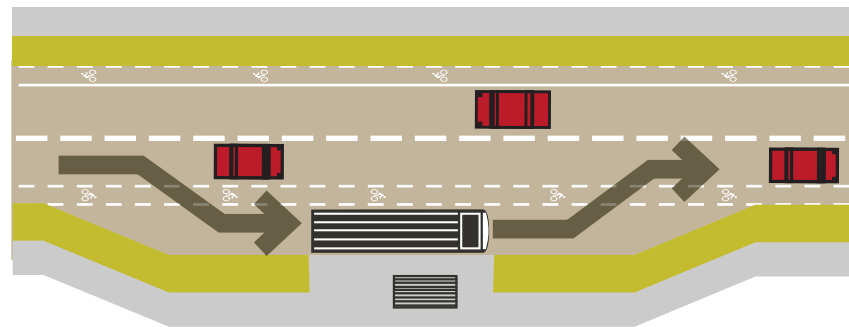


FIGURE 7.5.87 Bus Bay



### 7-5(G)(5)(iii) [Pavement Design](#)

1. A more durable pavement design (e.g. concrete) may be desirable for transit lanes, loading areas, station areas, and stops along Premium Transit and Major Transit corridors with high frequency of bus service (i.e. at least 4 buses per hour).
2. Specific pavement design and thickness should be considered based on factors such as expected vehicle traffic and subgrade conditions.
3. Typical gross bus weights including vehicle and passengers are 40,000 lbs. for standard buses and 60,000 lbs. for articulated buses.

### 7-5(G)(5)(iv) [Transit Conflicts with Bicycles](#)

1. Parallel networks in which bicycle facilities are provided on a nearby street are an appropriate means of minimizing conflicts.
2. Where transit service operates in mixed-flow traffic and coincides with on-street bicycle lanes, signage and pavement markings should be provided to improve awareness for cyclists and bus drivers. Preferred treatments include dashed lines along bicycle lanes at the entrance to the bus stop area.

3. Rerouting of bicycle lanes and boarding islands that direct bicyclists behind a transit stop may be employed in areas with sufficient right-of-way and high levels of conflict. See [NACTO's Transit Street Design Guide](#) for information on boarding islands and other treatments to alleviate conflicts between bicyclists and transit vehicles.

### **Section. 7-5(G)(6) Dedicated Transit Infrastructure**

1. Dedicated transit infrastructure refers to the portion of the road or right-of-way allocated exclusively for transit vehicles and associated improvements. This design approach reduces traffic delays and conflicts and improves transit travel time reliability.
2. Dedicated transit infrastructure may take the form of a separate lane or transit guideway and may be located curbside or in the median.
3. Dedicated transit lanes may be shared use under limited contexts, such as for emergency response, providing business access along a curbside lane, or through time-of-day restrictions.
4. Signage and pavement markings are necessary where physical separations between dedicated transit infrastructure and general purpose travel lanes do not exist.
5. Dedicated transit infrastructure is most appropriate along Premium Transit and Major Transit corridors.
6. See the [NACTO Transit Design Guide](#) or other documents considered appropriate by ABQ RIDE and/or Rio Metro RTD for additional guidance on dedicated transit infrastructure.
7. See the [MUTCD](#) for guidance on lane striping and pavement markings required for dedicated transit infrastructure.

#### **7-5(G)(6)(i) [Curbside Transit Lanes](#)**

1. Dedicated curbside bus transit lanes should be 10-12' in width not including the gutter pan, with 11' width preferred. Narrower lanes are most appropriate when operating speeds are 25 MPH or below, or where right-of-way is severely constricted.
2. Lane widths at stop locations may be reduced to 10'.
3. Curbside lanes may be separated by concrete barrier or rumble strip depending on the roadway design speed and available right-of-way.
4. If right-of-way is constrained and no landscape buffer currently exists, a minimum 2-4' separation, including the gutter, should be provided between the sidewalk and the curbside transit lane.
5. Curbside transit lanes may be used for business access or right turns. Alternatively, right turns may be restricted to signalized turning movements.

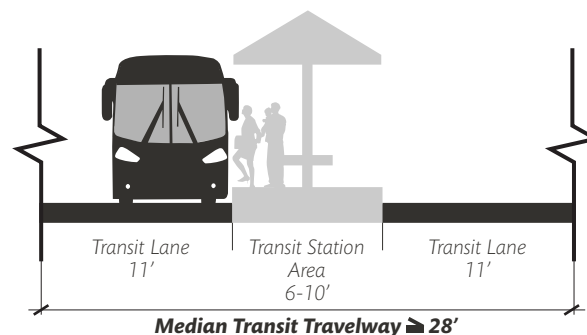
#### **7-5(G)(6)(ii) [Median Transit Lanes](#)**

1. Median transit lanes should be 11-13', with a recommended width of 12'. The lane width may be reduced if there are guideways or tracks to steer transit travel.
2. Median transit lanes and center platform stations require a minimum of 28' for the boarding and alighting area and dedicated lanes on both sides (see [FIGURE 7.5.88](#)).
3. Some form of separation, such as a raised curb or rumble strips, is desirable between the transit lane and adjacent general purpose lanes.



- Roadway designs must accommodate left turns at regular intervals through dedicated turn lanes and protected signals.

FIGURE 7.5.88 Median Transit Lanes and Center Platform Station



### 7-5(G)(6)(iii) [Queue Jump Facilities](#)

- Queue-jumps are short transit-only facilities at intersections that are combined with signal prioritization to allow for buses to enter traffic flow ahead of general purpose travel lanes. Queue jump facilities can be applied in the curbside travel lane where stops are located adjacent to signalized intersections or in a short-length special bus-only travel lane.
- Queue jump facilities may require additional right-of-way at intersections or the reallocation of a dedicated right-turn lane. Curbside queue jump facilities require right turns to be made from the nearest inside travel lane.
- Queue jump facilities are most appropriate along Major Transit and Premium Transit corridors.
- See the [NACTO Transit Design Guide](#) or other documents considered appropriate by ABQ RIDE and/or Rio Metro RTD for guidance on the design of queue jump facilities.

## Part. 7-5(H) On-Street Parking

### Section. 7-5(H)(1) General Provisions

Space within the Travel Way may be allocated to meet the parking needs of adjacent businesses and land uses. On-street parking also provides a buffer between pedestrians and moving traffic, reduces the need for off-street parking, and can serve as a speed management technique. On-street parking is generally located alongside the curb.

#### 7-5(H)(1)(i) [Appropriateness of On-Street Parking](#)

- On-street parking is generally permitted on local streets unless prohibited or restricted by street signage.
- On collectors and above, on-street parking is most appropriate within designated Centers, along Main Street Corridors, and near other high pedestrian-activity areas. See the Priority Street Element Matrix ([Comprehensive Plan, Table 7-5](#)) for the level of appropriateness for different Comprehensive Plan-designated Corridors.
- On-street parking is generally prohibited outside of designated Centers and Main Streets where posted vehicle speeds exceed 30 MPH and traffic

volume is greater than 10,000 vehicles per day except at the discretion of the City Engineer.

4. Outside of designated Centers, along Main Street Corridors, and other high pedestrian-activity areas, the City of Albuquerque in its sole discretion may consider on-street parking along arterial roadways in limited circumstances. Areas that may be considered include Metropolitan Redevelopment Areas and other locations that support economic development.
5. Consideration of on-street parking may require studies of parallel routes, operating speeds, traffic volume, drainage concerns, sight lines, and available right-of-way.

#### **7-5(H)(1)(ii) Types of On-Street Parking**

On-street parking options includes reverse angle parking (also referred to as back-in angle parking), parallel, and head-in angle parking.

##### **7-5(H)(1)(ii)(a) Reverse Angle Parking**

1. Per the Comprehensive Plan, reverse angle parking is the preferred arrangement for on-street parking, where right-of-way permits. Reverse angle parking offers the clearest sightlines for motorists to see approaching cyclists and other vehicles.
2. Where practical and where sufficient right-of-way exists, reverse angle parking should be used on bicycle routes, bicycle boulevards, and roadways with bicycle lanes.
3. Reverse angle parking is most appropriate on low-speed (25 MPH or less) and low-volume roadways.

##### **7-5(H)(1)(ii)(b) Parallel Parking**

1. Parallel on-street parking is a desirable option in locations with limited right-of-way and higher volume streets.
2. Parallel parking shall be prohibited on streets with speed limits above 35 MPH.

##### **7-5(H)(1)(ii)(c) Head-in Angle Parking**

1. Head in angle parking is the least preferred option, but is most appropriate on roadways with speeds below 35 mph and without bike facilities.

#### **7-5(H)(1)(iii) ADA/PROWAG Accessible On-Street Parking**

See [Section. 7-5\(K\)\(5\)](#) for ADA/PROWAG parking space dimensions. ADA/PROWAG accessible parallel on-street parking may be placed only where sufficient right-of-way exists for the loading/unloading area.

### **Section. 7-5(H)(2) Design Guidance**

#### **7-5(H)(2)(i) General Provisions**

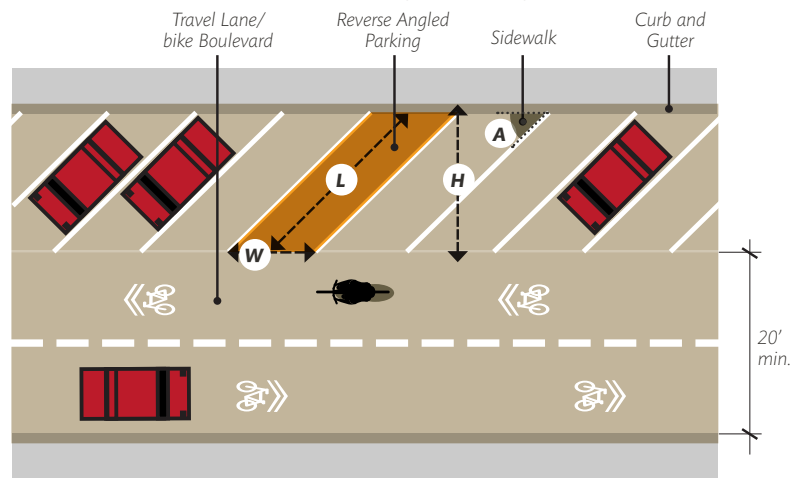
1. The type of on-street parking treatment depends on the location, roadway conditions (e.g., vehicle travel speeds and traffic volume), corridor designation or functional classification, and available right-of-way.
2. On-street parking may be combined with curb extensions to reduce pedestrian crossing distance, to create additional space in the landscape/buffer zone, or to improve access to transit stops.

3. Adequate clear sight triangles must be provided for all on-street parking spaces.

### 7-5(H)(2)(ii) [Reverse Angle Parking Design Guidance](#)

1. Sufficient right-of-way is required to ensure 20' of clear roadway width located between the end of the parking stall and the face of curb or the parking stall on the opposite side of the street. See [FIGURE 7.5.89](#).
2. Signage demonstrating the appropriate technique is strongly recommended for reverse angle parking.
3. The preferred angle for reverse angle parking is 60°.
4. The stall width should accommodate a minimum 8.5' wide and 18' long vehicle space. See [FIGURE 7.5.89](#) and [TABLE 7.5.55](#) for dimensions of angled parking.
5. Parking barriers and/or extended shy zones in the landscape/buffer zone are desirable to ensure vehicles with long rear overhangs do not reduce pedestrian access route or strike streetside elements.

**FIGURE 7.5.89 Dimensions for Angle Parking**



**TABLE 7.5.55 Dimensions for Angle Parking**

Angle (A)	Stall Length (L)	Stall Width (W)	Stall Depth (H)
45°	26.5'	12'	18.7'
60°	22.9'	9.8'	11.5'
75°	20.3'	8.8'	19.6'

### 7-5(H)(2)(iii) [Parallel Parking Design Guidance](#)

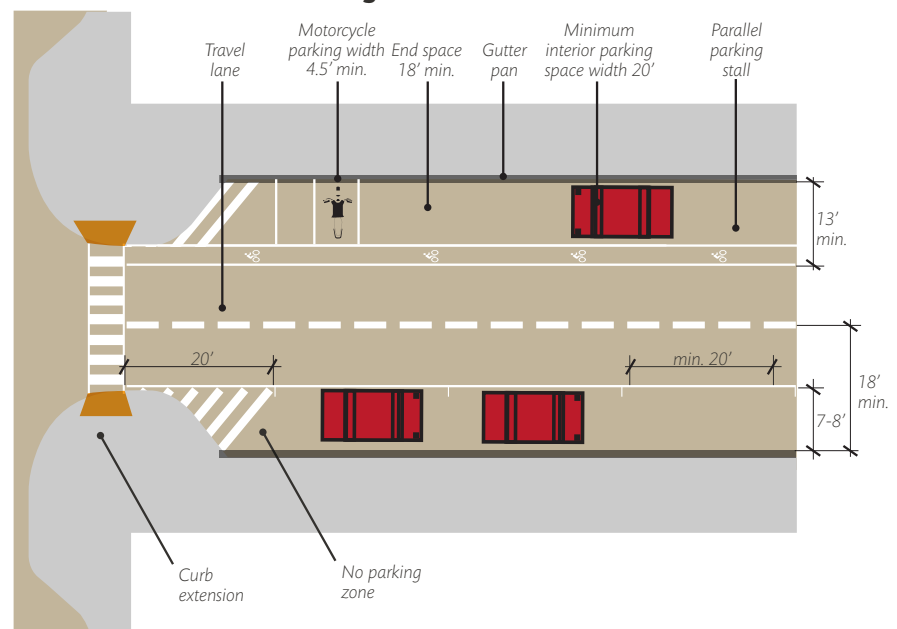
1. The width of on-street parallel parking stalls is 7-8.5', with wider stalls preferred on commercial streets with higher levels of parking turnover and on streets with speeds greater than 25 MPH. See [TABLE 7.5.56](#).

**TABLE 7.5.56 Minimum Parallel Parking Stall Width by Speed Limit**

Speed Limit	Stall Width
25 MPH	7'
30-35 MPH	8'

- The gutter pan may be used as part of the stall width.
- Where parallel on-street parking is adjacent to a bicycle lane (and there is insufficient space for reverse angle parking), the minimum combined width for the bike lane and the parallel parking stall is 13' (with a recommended 7'-wide parallel parking stall and a 6'-wide bike lane).
- The combined width of a parallel on-street parking stall and the adjacent travel lane should be a minimum of 18'.
- A 1.5' shy zone space or offset shall be provided between the curb edge and any vertical elements in the landscape/buffer zone.
- Individual stalls may be marked to increase the parking capacity. The minimum stall length for interior spaces shall be 20', and all end spaces shall be a minimum 18' long. See [FIGURE 7.5.90](#).
- Per [MUTCD](#), there shall be a 20' long space between the crosswalk or pedestrian crossing and the nearest on-street parking space. A curb extension may be used within that 20' area.

**FIGURE 7.5.90 Parallel Parking Dimensions**



**7-5(H)(2)(iv) [Head-in Angle Parking Design Guidance](#)**

- See [TABLE 7.5.55](#) for preferred dimensions on angle parking.
- See the [ITE Designing Walkable Urban Thoroughfares](#) or other manual approved by the City Engineer for additional guidance on head-in angle parking.

### 7-5(H)(2)(v) [On-Street Bicycle and Motorcycle Parking](#)

1. Excess space between the end parking space nearest to the intersection and the no-parking zone may be striped for on-street motorcycle parking or bicycle parking (See [FIGURE 7.5.90](#)).
2. On-street parking for motorcycles and bicycles may be used in lieu of a parking stall at the discretion of the City Engineer.
3. On-street motorcycle parking stalls should have a minimum width of 4.5 feet.
4. Per the motorcycle parking ordinance ([O-16-28](#)) and the [City Traffic Code](#), in areas where on-street parking is regulated by parking meters, at least three on-street parking spaces shall be designated as free motorcycle, moped, or motor scooter parking for every three contiguous blocks of metered on-street parking. This provision does not apply if it would require the removal of any regular on-street metered parking space.
5. Bicycle parking should be in the form of a corral or other vertical feature that clearly demarcates the space as intended for bicyclists only. Corrals are most appropriate at street corners. See [FIGURE 7.5.91](#) for examples.

**FIGURE 7.5.91 Bicycle Parking Corral Examples**



### Section. 7-5(H)(3) **Maintenance and Parking Agreements**

#### 7-5(H)(3)(i) [Publicly Maintained On-Street Parking](#)

If the City elects to create on-street parking in the public right-of-way, the City will maintain the parking including the routine sweeping, debris removal, snow removal, ice removal, and any necessary re-striping and repaving

#### 7-5(H)(3)(ii) [Private Parking Agreements](#)

1. If an applicant develops or redevelops on-street parking in the public right-of-way for its exclusive use, then the applicant shall enter into a parking agreement with the City. The parking agreement shall require the applicant to pay an annual fee to the City for the right to post signs permitting private, exclusive parking, and will require the applicant to construct and maintain the parking spaces, including the routine sweeping, debris removal, snow removal, ice removal, and any necessary re-striping. Under

- the parking agreement, the City may repave the parking spaces when repaving the adjacent roadway.
2. If the applicant develops or redevelops on-street parking in the public right-of-way for public, non-exclusive use, then the applicant will enter into a parking agreement with the City. The parking agreement will not require the payment of an annual fee, but will require the applicant to construct and maintain the parking spaces, including the routine sweeping, debris removal, snow removal, ice removal, and any necessary re-striping. Under the parking agreement, the City may repave the parking spaces when repaving the adjacent roadway.
  3. If the construction of on-street parking is shared by the City and an applicant, the parties shall enter into a parking agreement concerning the maintenance responsibilities of each party and the collection and payment of any fees.

### **Section. 7-5(H)(4) Creation of New On-Street Parking During Site Development**

#### **7-5(H)(4)(i) [Procedures](#)**

1. The addition of on-street parking to support a site development may be permitted as described in [7-5\(H\)\(1\)\(i\)](#). A pre-design meeting with the City Engineer to review the conceptual layout is required.
2. For approval of new on-street parking to support a site development, the following criteria must be met:
  - a. *The parking and adjacent sidewalk must be within City of Albuquerque right-of-way or public easement.*
  - b. *Public notification must be given to owners/tenants who are within 200 feet of the proposed parking area.*
  - c. *The posted speed must be less than 35 miles per hour.*
  - d. *A work order must be obtained for initial construction. Work orders require engineered plans. Barricading and excavation permits will be required for the work order and for any maintenance.*
3. Meeting the above criteria does not guarantee approval if there is a significant safety issue that would be created by allowing on-street parking. If approval is granted by the City of Albuquerque, this approval does not grant vested rights for on-street parking. The City of Albuquerque retains the right, at its discretion, to remove on-street parking and the applicant shall agree to waive any claim of damage if on-street parking is removed. The standard criteria for on-street parking credits, pursuant to [IDO Section 14-16-5-5\(C\)\(4\)\(e\), Parking & Loading](#) shall apply.

### **Section. 7-5(H)(5) Parklets**

#### **7-5(H)(5)(i) [Definition and Appropriateness](#)**

1. Parklets, also locally referred to as parquitos, are small public areas or commercial spaces supporting an adjacent business in which a curbside parking space is replaced with a seating area or gathering space that encourages additional activity along a street. Parklets may span one or more on-street parking spaces (or the equivalent curbside space).

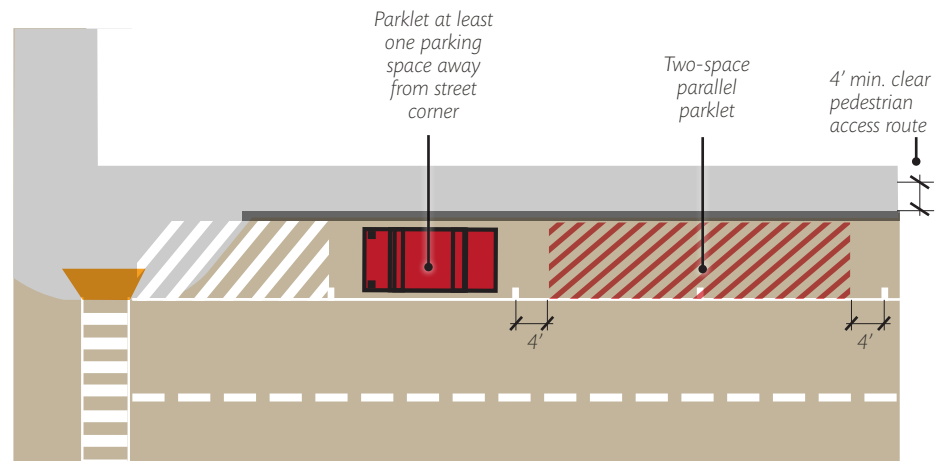
2. Parklets are generally the result of an agreement between the City and the business or property owner that is converting the parking space for commercial purposes. Coordination with the Parking Division is required, including agreement over fees associated with lost parking revenue.
3. Parklets require approval by the City Engineer and a revocable permit or other agreement to convert a public parking space for commercial use.
4. The City reserves the right to reject a parklet if it will interfere with upcoming street improvements, affects drainage, or creates challenges for street maintenance.
5. Construction and maintenance is the responsibility of the developer.
6. Parklets are most appropriate on streets with speed limits of 25 mph or less, and may be considered on streets with speed limits over 25 mph on a case-by-case basis.
7. Parklets may be sited along the curb on streets where on-street parking spaces exist, or sufficient space for on-street parking is available.

### **7-5(H)(5)(ii) Design Guidance**

1. The width of the parklet must not be greater than the designated on-street parking spaces. See [FIGURE 7.5.91](#).
2. Parklets may not be constructed over access points for utilities such as manhole covers, storm drain inlets, or in front of fire hydrants.
3. Parklets shall not be located at street corners and shall be located a minimum 20 ft from the edge of the on-street parking zone.
4. A minimum buffer of 4' is required between the edge of the parklet and the adjacent parking space(s).
5. A minimum 2' buffer is required between the edge of the parklet and any active driveway(s).
6. All parklets must comply with the ADA/PROWAG and be accessible to all users. Parklets are generally not permitted on streets with a grade greater than 5%, unless the parklet provides safe access for all users.
7. The parklet shall be flush against the curb or connected via an ADA/PROWAG accessible ramp.
8. A vertical separation from the adjacent roadway is required. The separation shall be located adjacent to the roadway as well as on the end on the parklet.
9. Where a parklet is located next to a bicycle lane, there must be a minimum 5' of space from the edge of the parklet to the nearest general purpose travel lane.
10. All parklets shall accommodate street drainage.
11. All parklet designs shall be approved by the City Engineer and should reference the [San Francisco Parklet Manual \(2015\)](#) or approved alternative for additional considerations.



FIGURE 7.5.92 Parklet Location and Examples



## Part. 7-5(I) Geometric Design Criteria

The criteria presented within this section are major controlling factors in the design of streets. Designers shall carefully apply these criteria to individual design circumstances. Suitable transitional elements must be provided between changes in geometric configuration, pavement, curb, and drainage carrying aspects of the ultimate street design.

The following criteria are discussed in this section:

1. General Design Criteria
2. Horizontal Alignment
3. Superelevation
4. Vertical Alignment
5. Sight Distance
6. Intersection Design
7. Medians and Turn Lane Design

The standards contained in the DPM are intended to provide direction in the design of transportation facilities. While most of the design parameters that should be used are provided in the following pages, unusual conditions may occur in some projects.

Where additional guidance and explanation is needed, the designer should refer to the current version of publications from the following sources:

1. American Association of State Highway and Transportation Officials (AASHTO)
2. Institute of Transportation Engineers (ITE)
3. National Association of City Transportation Officials (NACTO)

Specific publications that may be referenced in the design process include:

1. [Roadside Design Guide](#), AASHTO
2. [Highway Capacity Manual](#) (HCM), Transportation Research Board
3. [Manual on Uniform Traffic Control Devices](#) (MUTCD), Federal Highway Administration

**NOTE:** many of the tables contained in the Geometric Design Criteria section of the DPM are taken from the 6th edition (2011) of the AASHTO publication, "A Policy on Geometric Design of Highways and Streets" (referred to as the AASHTO Green Book). Equivalent tables from updated versions of the AASHTO Green Book should be referenced when they become available.

4. *Public Right of Way Access Guide* (PROWAG)

**Section. 7-5(1)(1) General Design Criteria**

Streets shall be designed to avoid long straight segments on residential streets and abrupt, inconsistent changes in either horizontal or vertical alignment. Balance is necessary to avoid hazardous situations and help meet driver expectations.

The fundamental approach to street design is to first identify the design speed for the facility; see Table TABLE 7.5.54 Street Element Dimensions. The nominal vehicle type must also be considered. The design is accomplished by selecting the appropriate characteristics to accommodate the design vehicle at the design speed in a safe and efficient manner.

**Section. 7-5(1)(2) Horizontal Alignment**

Normal crown is generally preferred in urban streets to promote control of drainage and nuisance stormwater flows. This preference will lead to the use of longer radius horizontal curves in most major street circumstances.

*TABLE 7.5.57* provides the minimum centerline radius for a normal road with a 2% crown or 2% cross-slope maximum. Roads with superelevation, cross-slopes greater than 2%, and with design speeds greater than 45 mph refer to the *AASHTO Green Book* (latest edition).

<b>TABLE 7.5.57 Minimum Centerline Radius for a Normal Road</b>	
<b>Design Speed (mph)</b>	<b>Radius* (ft)</b>
15	50
20	107**
25	198**
30	333
35	510
40	762
45	1039

**Section. 7-5(1)(3) Superelevation**

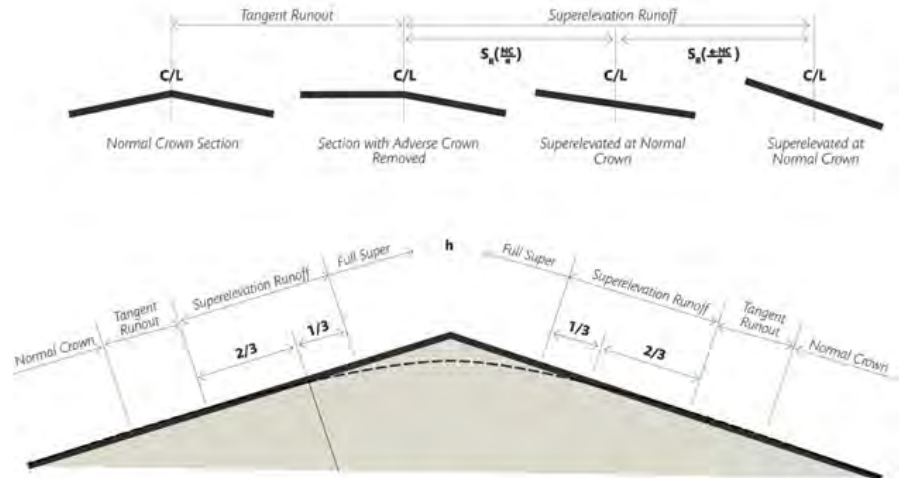
The use of superelevation (i.e., outside edge of pavement higher than inside edge) should be limited in an urban setting due to the lower speeds of the roadways. Superelevation shall not be used on local streets. Refer to the current *AASHTO A Policy on Geometric Design of Highways and Streets*, latest edition, for guidance on superelevation rates.

The use of superelevation requires the careful design of transitions leading to/from normal crown sections to/from superelevated sections. Designs involving

\* From AASHTO 2011 TABLE 3-13b. Minimum Radii and Superelevation for Low-Speed Urban Streets  
 \*\* A local residential street with 90° or near 90° turns may be designed with a minimum centerline radius of 75' with the approval of the Traffic Engineer.

such transitions should show sufficient detail to demonstrate that drainage is being accommodated (i.e. no low points) and to provide sufficient information for adequate construction staking to ensure the desired result. Vertical profile lines for all curblines as well as detailed superelevation run-out plans shall be provided for superelevation design. See [FIGURE 7.5.93](#) for a visual representation of a superelevation runout plan.

**FIGURE 7.5.93 Example Superelevation Runout Plan**



### Section. 7-5(1)(4) Vertical Alignment

Long, flat gradients are undesirable because of poor drainage characteristics. The minimum desirable gradient consistent with acceptable drainage is 0.5 percent and, as such, should be observed as a general design principle. Long, steep gradients are also undesirable since they are difficult for heavier vehicles to negotiate at desirable traffic speeds. See [Chapter 6](#) for additional street hydraulic requirements.

Vertical curve criteria stated in [TABLE 7.5.58](#) is from the [2011 AASHTO Green Book](#). In the application of these criteria, the designer will be expected to apply sound engineering judgment in combining vertical geometry with horizontal geometry. Extreme vertical undulation is not acceptable. Vertical changes in grade occurring simultaneously with horizontal alignment changes must be carefully considered to preserve the required sight distance consistent with the design speed of the street. Horizontal curvature should not be introduced at or near the top or bottom of a crest or sag vertical curve. Intersection sight distances must be maintained in all designs. Intersections on vertical curves should be placed at the crest where visibility in both directions can be maintained.

The values for  $K$  shown in the following tables for Crest and Sag Vertical Curves are to be used in determining the minimum length of vertical curve required by the use of the relationship

**EQUATION 7.65**  $L = K \cdot A$

**where:**

**L** = Length of vertical curve in feet

**A** = Algebraic difference in grades expressed in percent

**K** = Design value indicative of rate of curvature

Lengths of vertical curves longer than the minimums resulting from the use of K values shown should be used wherever possible; however, K should not exceed 167' when curb and gutter is used.

If grade changes without vertical curves are used, as allowed in the following table, a minimum of 50' must be maintained between the vertical point of intersections.

**TABLE 7.5.58 Design Controls for Vertical Curves\***

	Design Speed (MPH)	Minimum Length Vertical Curve (FEET)	K Value For Crest Stopping Sight Distance	K Value For Sag Stopping Sight Distance	Maximum Grade Change Allowed Without Vertical Curve - %	Maximum Grade Allowed %
<b>Arterials/ Collectors</b>	50	150	84	96	0.4	6
	45	135	61	79	0.4	7
	40	135	44	64	0.4	7
	35	100	29	49	0.7	8
<b>Major Local</b>	30	100	19	37	0.8	8
<b>Local Residential</b>	25	75	12	26	1	8
<b>Local Residential: Access Streets, Cul-de-Sacs, Alleys</b>	20	60	7	17	1	12
<b>Local Leg of T Intersection</b>	15	45	3	10	1	12
<b>Local Industrial / Commercial</b>	30	90	19	37	1	8

**Section. 7-5(l)(5) Sight Distance**

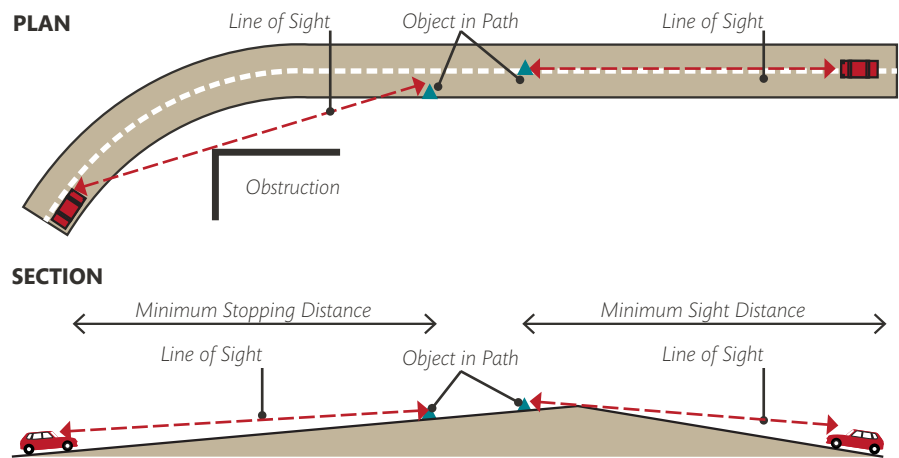
**7-5(l)(5)(i) [General Provision](#)**

1. Roadways, intersections, site entrances, and driveways need to have sufficient visibility to allow motorists to easily travel and enter or exit safely, as well as protect pedestrians and bicyclists.
2. Visibility must be maintained in accordance with the current AASHTO guidelines for roadway design intersection visibility. The information below is based on the 2011, 6th Edition of *A Policy on Geometric Design of Highways and Streets*.
3. Depending on specific site conditions, adjustments to sight distances may be required. These factors may include, but are not limited to, side street approach grades greater than 3%, median widths of the crossing street, or skewed intersections. Waivers may also be granted in Downtown, Urban Centers, and Mixed Use Zones.

### 7-5(I)(5)(ii) [Stopping Sight Distance](#)

1. Stopping Sight distance is the length of roadway visible to the driver. The minimum sight distance available on the roadway should be sufficiently long to enable a vehicle traveling at or near the design speed to stop or change lanes before reaching a stationary object in its path.
2. The method of measuring stopping sight distance along a roadway is illustrated in [FIGURE 7.5.94](#).
3. Minimum stopping sight distances, as shown in , shall be provided in both the horizontal and vertical planes for planned roadways as related to assumed driver's eye height and position.
4. Adequate sight distance shall be provided at all driveway access points.
5. Where there are sight obstructions (such as walls, cut slopes, buildings, or other hazards) on the inside of curves, changes in roadway alignment may be required to obtain adequate stopping sight distance if the sight obstruction cannot be removed.

**FIGURE 7.5.94 Stopping Sight Distance**



**TABLE 7.5.59 Minimum Stopping Sight Distance**

Design Speed (mph)	Upgrades			Flat	Downgrades		
	9%	6%	3%		0%	-3%	-6%
25	140	145	150	155	160	165	175
30	180	185	200	200	205	215	230
35	225	230	240	250	260	275	290
40	270	280	290	305	315	335	355
45	320	330	345	360	380	400	430
50	375	390	405	425	450	475	510

### 7-5(I)(5)(iii) [Intersection Sight Distance](#)

1. Intersections should be planned and located to provide as much sight distance as possible. A basic requirement for all controlled intersections is that drivers must be able to see the control device well in advance of per-

- forming the required action. Stopping sight distance on all approaches is needed at an all-way stop. Obstruction-free sight triangles shall be provided for both left and right turns.
2. Intersections of local streets with major streets classified as collector or above shall not be located at or near horizontal curves without special evaluation of intersection sight distance. The location of an intersection on the “inside” of a horizontal curve is a situation that will typically result in intersection visibility problems. The location of any property lines, fences, or other obstructions will need to be evaluated to ensure that the minimum sight distance is maintained. See [Figure 9-15 Intersection Sight Triangles in, A Policy on Geometric Design of Highways and Streets, 2011 AASHTO](#), or later edition.
  3. Adjustments to the intersection sight distance must be made for side street approach grades greater than 3%, skewed intersections, and other types of roadway geometry in accordance with [Section 9.5.3 Intersection Control of the AASHTO guidelines \(2011\)](#) or latest addition.
  4. At any intersection of two roadways, a sight triangle shall be provided for an unobstructed path of sight. The sight distance triangle can be defined by connecting a point that is along the minor street’s edge of pavement and 15 feet from the edge of pavement of the major street, with a point that is distance (L) along the major street’s edge of pavement as shown in [FIGURE 7.5.95](#).
  5. [TABLE 7.5.60](#) summarizes the required sight distance (L) along the major road for a stopped vehicle on the minor street to cross the major street. If a roadway is divided with a median width of 20 feet or more for passenger vehicle crossings or 40 feet or more for truck crossings, the required sight distance may be based on a two-stop crossing and consideration given to the width of each one-way section at a time.

**FIGURE 7.5.95 Intersection Sight Distance**

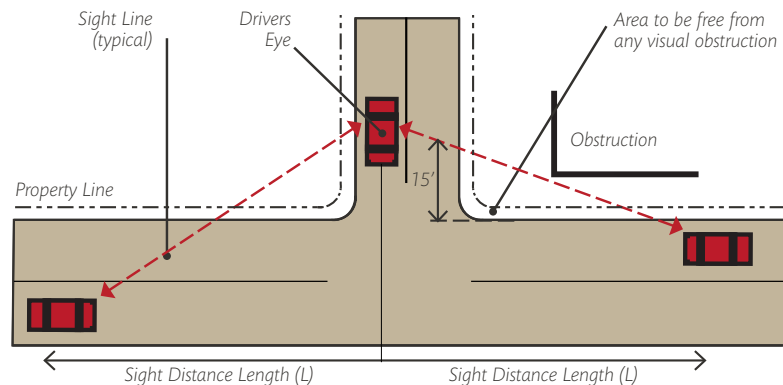
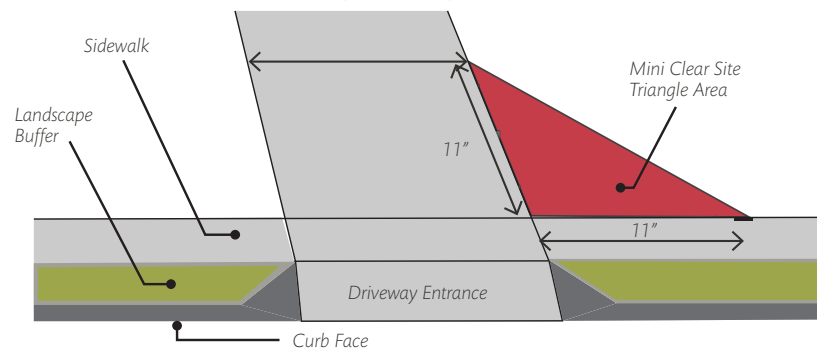


TABLE 7.5.60 Minimum Intersection Sight Distance						
Speed Limit (mph)	Minimum Intersection Sight Distance (ft)					
	2 Lane Undivided		3 Lane Undivided or 2 Lane Divided w/ 12' Median		4 Lane Undivided	
	Left Turn	Right Turn	Left Turn	Right Turn	Left Turn	Right Turn
20	230	200	240	200	250	200
25	280	240	300	240	320	240
30	340	290	360	290	380	290
35	390	340	420	340	440	340
40	450	390	480	390	500	390
45	500	430	530	430	570	430
50	560	480	590	480	630	480

7-5(I)(5)(iv) [Mini Clear Sight Triangle](#)

Driveways need to maintain the mini sight triangle as shown in [FIGURE 7.5.96](#). This triangle starts at the sidewalk and measures 11 feet on a side.

FIGURE 7.5.96 Mini Clear Sight Triangle



7-5(I)(5)(v) [Visibility for Site Entrances and Driveways](#)

Site entrances and driveways shall be designed to preserve the clear sight triangle free of visual obstruction as described in [7-5\(I\)\(5\)\(iii\)](#) and [7-5\(I\)\(5\)\(iv\)](#) above.

7-5(I)(5)(vi) [Sight Distance Note](#)

The following note is required in all site plans: Landscaping, signage, walls, fences, trees, and shrubbery between three (3') and eight feet (8') tall (as measured from the gutter pan) are not allowed within the clear sight triangle.

7-5(I)(5)(vii) [Objects Permitted in the Clear Sight Triangle](#)

Objects, that may be located in the sight triangle, include, but are not limited to, hydrants, utility poles, utility junction boxes, and traffic control devices provided these objects are located to minimize visual obstruction. Objects under eight inches (8") wide may be allowed.



## Section. 7-5(l)(6) Intersection Design

### 7-5(l)(6)(i) [Intersection Traffic Control Typologies](#)

#### 7-5(l)(6)(i)(a) [General Provisions](#)

1. Traffic control is applied at all locations where two or more roads intersect to manage the movement of multiple users and directions of traffic. The traffic control technique depends on the traffic volume, Corridor type, and functional class of the roadways, with greater control required on higher speed and higher use facilities.
2. All traffic control devices should be designed in accordance with the standards and specifications as published in the most recent version of the [Manual on Uniform Traffic Control Devices \(MUTCD\)](#) and the current [City of Albuquerque Standard Drawings](#).

#### 7-5(l)(6)(i)(b) [Signalized Intersections](#)

1. A signal warrant analysis is required before a new traffic signal is added. See [Article 7-6 Traffic Studies](#) for further guidance.
2. Traffic signals may be removed and/or converted to a stop sign-controlled intersection if a signal warrant analysis is conducted and determines that a signalized intersection is unnecessary.
3. See [Article 7-5 Design Standards](#) for guidance on the spacing of signalized intersections and guidance related to signalized pedestrian crossings.
4. Where a development will cause traffic that warrants a signal, the developer will be financially responsible for all or a portion of the signal installation at the discretion of the City Engineer.

#### 7-5(l)(6)(i)(c) [Unsignalized Intersections](#)

1. An unsignalized intersection is an at-grade intersection in which the flow of traffic is not controlled by a traffic signal. Unsignalized intersections may be STOP-sign controlled, YIELD sign-controlled, or uncontrolled.
2. Unsignalized intersections are appropriate for locations where the vehicle and/or pedestrian volumes do not meet the thresholds set forth for new signals in the MUTCD.
3. The typical unsignalized intersection control shall be two-way stop control, which provides stop control on the secondary intersection approaches (i.e. side-street) and free flow on the primary street.
4. All-way stop control may be provided at intersections where traffic volumes or other conditions are consistent with the warrants set forth in the current edition of the MUTCD.
5. YIELD sign-controls may be placed as part of the entrance to a traffic circle, roundabout, channelized right turn, or at the intersection approach of a minor road.
6. Uncontrolled intersections (i.e. intersections without any signage or traffic control) are generally discouraged and are only appropriate at the intersection of two local streets.

#### 7-5(l)(6)(i)(d) [Neighborhood Traffic Circles](#)

1. Traffic circles are small raised islands placed in intersections around which traffic circulates. Traffic circles are intended to manage speeds in neighborhood settings by impeding through movements and forcing drivers to travel at slower speeds through intersections.

2. Yield signs may be used as traffic control at the approaches of the traffic circle.
3. Traffic circles are most appropriate at intersections on local and major local streets where large vehicle traffic is not a major concern but speeds, volumes, and safety are recorded problems. See [Part. 7-5\(L\) Traffic Calming](#) and the [City of Albuquerque Neighborhood Traffic Management Program \(NTMP\)](#) for additional guidance.

#### **7-5(I)(6)(i)(e) Roundabouts**

1. Roundabouts are a form of intersection control in which motorists (and cyclists) travel counter-clockwise around a center island and yield at entry points to traffic already circulating the roundabout.
2. A roundabout may be constructed at intersection locations along collectors and arterials where it may be desired in order to enhance intersection capacity, reduce vehicle speeds along a corridor, reduce the incidences of severe crashes, address irregular intersection geometry, or enhance intersection aesthetics. Roundabout design and bicycle and pedestrian accommodations shall be designed in accordance with the criteria set forth in the most recent version of the [FHWA manual, Roundabouts: An Informational Guide](#), or a more recent comparable document acceptable to the City Engineer.
3. Care should be taken in order to ensure roundabouts are not located in close proximity to adjacent stop or signal controlled intersections where long queues may back up into the roundabout.
4. Additional right-of-way may be required for the construction of roundabouts. The purchase of right-of-way shall be considered as part of the design cost for roundabouts proposed along existing facilities.
5. See the current [MUTCD](#) for guidance on signage and pavement markings for bicyclists and pedestrians at roundabouts. Per the MUTCD, bicycle lanes are not permitted in roundabouts.
6. See [NACTO](#), [AASHTO](#), or other approved design guides for pedestrian and bicycle design considerations through roundabouts.

#### **7-5(I)(6)(ii) Intersection Design Considerations**

##### **7-5(I)(6)(ii)(a) Angle of Intersection**

1. Streets shall be designed to intersect at right angles.
2. If an angled intersection is unavoidable the acute angles at intersections for all new streets shall be 80 degrees or greater. Consult the [AASHTO Green Book](#) for additional guidance on the effects of skewed intersections, including changes to the sight triangle and curb radii.
3. Intersections at less than 80 degrees require permission from the City Engineer.
4. See [Section. 7-5\(I\)\(7\)](#) for direction on spacing of intersections.

##### **7-5(I)(6)(ii)(b) Spacing of Intersections**

See [Article 7-5 Design Standards](#) for guidance on the spacing of signalized and unsignalized intersections along arterial roadways.

##### **7-5(I)(6)(ii)(c) Intersection Grading**

1. Intersections must be graded to provide characteristics consistent with the design speed of the through street. Projected curb flowline profiles through the intersection will be required for design review of intersections

involving arterial and collector streets. Alignment of arterial streets through intersections must be continuous without breaks in grade and meet the criterion for vertical curvature in [Table 3.9-2](#). Grades within the intersection need to be flat enough to minimize problems with turning vehicles and to keep stopping distances reasonable. Grades should also be steep enough to ensure that proper drainage occurs. Grades should be between 0.5% minimum and 3% maximum.

2. Minor leg approach tangent gradients to intersections should not exceed 4% from the projected curb flowline of the through street. Deviations from this standard will require approval by the City Engineer.
3. Street crowns should be reduced through intersections to promote driver comfort. See [Chapter 6](#) for guidance on drainage requirements at intersections.
4. Grades intended to serve as drainage water blocks may only be designed on minor approach legs of intersections. Design of water blocks shall be per DPM [Chapter 6](#) and grading and drainage plan.
5. The designer should specifically investigate intersection design to assure that design flows will not overtop curbs resulting in damage outside the right-of-way. Drop inlets should be located away from curb access ramps. Curb returns should be designed to avoid ponding.
6. Intersections should be located so as to avoid roadway segments that are highly superelevated. Intersection grading for superelevated roadways needs to take into account the issues of grade compatibility, cross-over crown, etc. to insure that the intersection will operate properly.

#### **7-5(I)(6)(ii)(d) Intersection Sight Distance**

Intersections should be designed to ensure that drivers have an unobstructed view as they approach or depart an intersection. Standards related to intersection sight distance can be found in [Section. 7-5\(I\)\(5\)](#)

#### **7-5(I)(6)(ii)(e) Bicycle and Pedestrian Accommodations**

1. See [Part. 7-5\(F\) Bikeways and Trails](#) for additional considerations related to bicycle travel at intersections.
2. See [Part. 7-5\(E\) Pedestrian Facilities](#) for guidance on sidewalks, curb ramp design, and intersection pavement markings and crosswalk design.

#### **7-5(I)(6)(ii)(f) Intersection Turn Lanes**

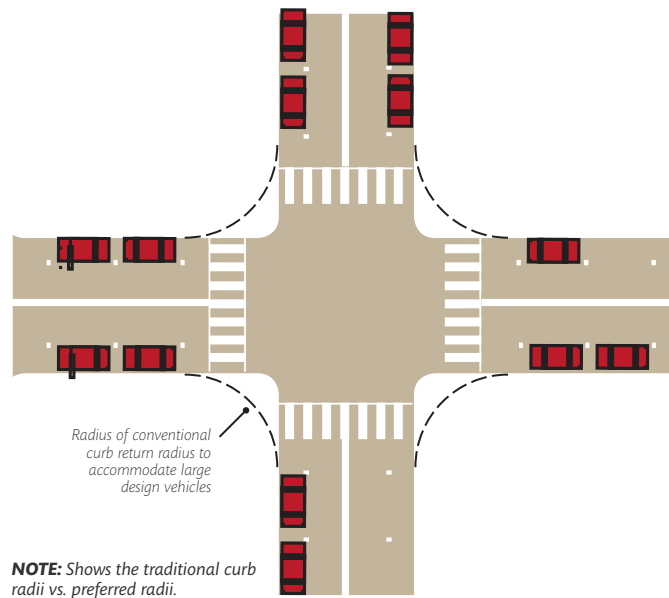
See [Section. 7-5\(I\)\(7\)](#) for guidance on turn lane design at intersections.

#### **7-5(I)(6)(iii) Curb Return Radii**

##### **7-5(I)(6)(iii)(a) Definition**

Curb returns are the curved corner formed by the intersection of two streets. Curb returns guide motor vehicle during turning movements, and are important for delineating pedestrian zones at intersections.

FIGURE 7.5.97 Standard Curb Return Radii Diagram



### 7-5(I)(6)(iii)(b) Design Considerations

1. See [TABLE 7.5.61](#) for recommended ranges for curb return radii.
2. Important factors for determining the size of curb return radii are the Corridor type and the location (i.e. inside or outside of a Center), and should be designed to ensure safe movement for all roadway users.
3. Desired curb return radii are provided in [TABLE 7.5.61](#) and are organized by Corridor type. The intersections of Corridors that carry higher traffic volumes at greater speeds generally have larger curb return radii. Turning radii of design vehicles should be checked during design. It is assumed that trucks and buses may need to swing wide to make right turns, but the design should discourage this movement where feasible. It is also assumed that large vehicles will turn into the middle or far lane if more than one lane is available.
4. Curb return radii are provided as ranges to ensure some flexibility, though the size of curb return radii should be minimized where possible. Smaller radii reduce vehicle speeds and reduce pedestrian crossing distance, and are particularly desirable in Centers and Premium Transit Station Areas, and along Multi-modal, Main Street, and Major Transit Corridors as defined in the Comprehensive Plan.
5. The design vehicle is generally an SU-30, though a smaller design vehicle is encouraged where feasible.
6. Curb return radii may be 15' or below within all designated Centers, regardless of Corridor types. If a 15' radius may not be achieved in Centers or along desired Corridors, the curb return radii shall be the low value provided in [TABLE 7.5.61](#).

7. The design standards for curb return radii reflect that local streets may serve commercial and industrial purposes, in which case larger radii may be required to support delivery vehicles and other large trucks.
8. Larger radii are appropriate in locations where large vehicles, including buses and delivery trucks, make regular turning movements.

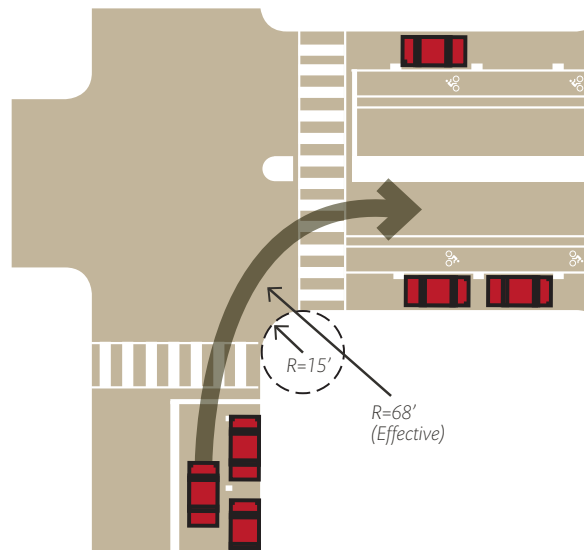
**TABLE 7.5.61 Curb Return Radii Table**

From/To	Commuter	Major Transit	Multi Modal	Main Street	Other Arterial	Minor Arterial	Collector	Local Commercial	Local Residential
Commuter	30-35'	25-30'	25-30'	25-30'	25-30'	25-30'	25-30'	25-30'	25-30'
Major Transit	25-30'	25-30'	20-25'	20-25'	20-25'	20-25'	20-25'	20-25'	20-25'
Multi Modal	25-30'	20-25'	20-25'	20-25'	20-25'	20-25'	20-25'	20-25'	20-25'
Main Street	25-30'	20-25'	20-25'	15-20'	20-25'	20-25'	15-20'	15-20'	15-20'
Other Arterial	25-30'	20-25'	20-25'	20-25'	25-30'	20-25'	20-25'	20-25'	20-25'
Minor Arterial	25-30'	20-25'	20-25'	20-25'	20-25'	20-25'	20-25'	20-25'	20-25'
Collector	25-30'	20-25'	20-25'	15-20'	20-25'	20-25'	15-20'	15-20'	15-20'
Local Commercial	25-30'	20-25'	20-25'	15-20'	20-25'	20-25'	15-20'	15-20'	10-15'
Local Residential	25-30'	20-25'	20-25'	15-20'	20-25'	20-25'	15-20'	10-15'	10-15'

**7-5(I)(6)(iii)(c) Effective Curb Radius**

The presence of bicycle lanes, bicycle buffers, and/or on-street parking can increase the “effective” radius, which takes into account the available space for a turning movement, rather than just the curb return itself. Curb returns may be designed according to the effective curb radius rather than the actual curb radius.

**FIGURE 7.5.98 Effective Curb Return Radii Diagram**



**7-5(I)(6)(iii)(d) Curb Extensions**

1. Where on-street parking lanes are provided, curb extensions may be considered for reducing the effective crosswalk width for pedestrians.

2. Curb return radii may be adjusted to allow sidewalk curb extensions for street crosswalk areas at intersections with local residential streets.

#### **7-5(I)(6)(iii)(e) Freight Accommodations**

1. Curb return radii may be increased along corridors with high levels of freight travel, or if one or more of the streets in question is impacted by a major freight traffic generator. In these cases, the curb return radii should correspond to a larger design vehicle.
2. For roundabouts, designers may consider incorporating mountable curbs, truck aprons, or other features that avoid the need for larger radii.

#### **7-5(I)(6)(iii)(f) Channelized Right Turn Lanes**

1. Channelized right turn lanes accommodate high levels of turning movements and encourage turning movements at higher speeds. Channelized right turns may be acceptable in locations with limited pedestrian activity and in locations where efficient traffic flow is particularly desirable, such as a Commuter Corridor. Channelized right turn lanes should not be a standard design feature in high-pedestrian activity areas.
2. If such a turn lane is considered necessary, the designer should consult an accepted national design manual, including [\*ITE Designing Walkable Urban Thoroughfares\*](#), and the City Engineer.
3. See [\*Section. 7-5\(I\)\(7\)\*](#) for additional guidance regarding restricted turning movements.

### **Section. 7-5(I)(7) Median and Turn Lane Design**

#### **7-5(I)(7)(i) Medians**

##### **7-5(I)(7)(i)(a) Definition and Appropriateness**

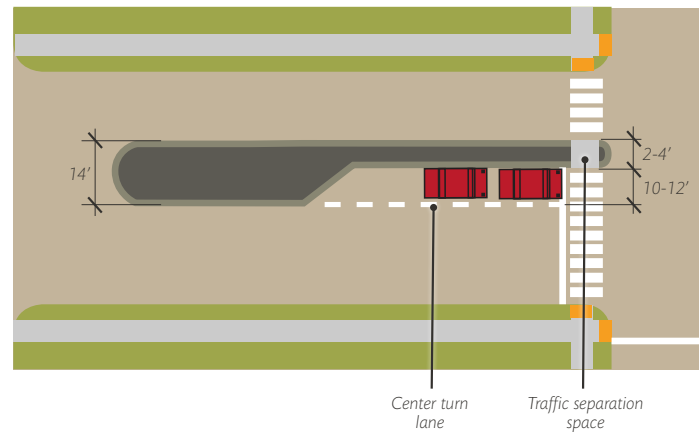
1. Medians are the center portion of the roadway that separates general purpose travel lanes moving in opposite directions. Medians frequently incorporate features to improve safety and operations by providing space for turning vehicles.
2. Center turn lanes may be incorporated as part of a median and interspersed with median islands. Medians may also serve as pedestrian or bicycle refuges, whether as raised features or through physical barriers, pavement markings, and signage that distinguishes the pedestrian safe zone as part of a designated crossing. Options for medians and center turn lanes include:
  - a. *Two-way left-turn lanes (TWTL)*
  - b. *Raised medians with intersection turn bays*
  - c. *Median refuges for pedestrians and cyclists*
  - d. *Raised landscaped medians*
3. Some form of raised or striped median is strongly preferred on principal and minor arterials, with wider medians required along segments with turn bays.
4. Median landscaping and pedestrian refuges are desirable in high-pedestrian activity areas and as space allows.

##### **7-5(I)(7)(i)(b) Design Considerations**

1. Median widths are measured from curb face to curb face or center of pavement stripe to center of pavement stripe.

2. Median refuges shall be a minimum 6' in width, with a preferred width of 8'-10'. See [Part. 7-5\(E\) Pedestrian Facilities](#) for more information on median refuge islands. See [Article 7-5 Design Standards](#) for guidance on pedestrian crossing locations.
3. For collector and arterial roadways where the median also serves as center turn lane space, the median turn lane width should be 10'-12', with wider turn lanes appropriate on higher speed roadways (i.e., above 35 MPH) and with an additional 2'-4' space separating traffic as indicated in [FIGURE 7.5.99](#).
4. Narrow medians (i.e., less than 6') are most appropriate for restricting turning movements and separating opposing traffic, and may be utilized for some landscaping purposes.
5. Medians should be a minimum of 6' for the placement of traffic signals.
6. Trees generally require a minimum 6' median. Placement and maintenance of street trees as part of median landscaping should ensure adequate clear zone and sight distance. See the current [AASHTO Roadside Design Guide](#) for clear zone recommendations, [7-5\(I\)\(5\)\(iv\)](#) for sight distance requirements, and [Chapter 11](#) for additional guidance on landscaping requirements.
7. See [Part. 7-5\(G\) Public Transit](#) for guidance on median-running transit infrastructure.
8. Raised medians may require drainage infrastructure, including a curb and gutter pan and drop inlet. See [Chapter 6](#) for drainage requirements.

**FIGURE 7.5.99 Median with Center Turn Lane**



### 7-5(I)(7)(ii) [Median Openings](#)

#### 7-5(I)(7)(ii)(a) [Definitions and Appropriateness](#)

1. Median openings, or median cuts, are an unobstructed section of a raised median that allow for left turns. Raised medians generally improve safety and traffic operations but reduce site access.
2. The frequency of median openings depends on the corridor type and the surrounding land use context.
3. Medians and access limitations shall be consistent with all restrictions contained in the [MRCOG inventory of roadway access limitations](#).

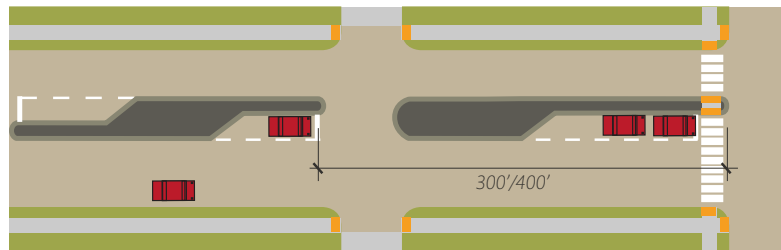
#### 7-5(I)(7)(ii)(b) [Spacing and Access Control](#)

1. See [Part. 7-5\(B\) Site Access Points](#) for guidance related to the spacing of curb cuts and driveway frequency.



2. Median openings shall follow guidance from [Article 7-5 Design Standards](#) and [Section. 7-5\(l\)\(6\)](#).
3. Where a median opening is desired, access to both sides of the street shall be considered. If development exists on both sides of the street, left-turn bays for both directions may need to be constructed.
4. Where an access point exists on the opposite side of the street, the center-line of the new access points shall be as closely aligned as conditions allow.
5. If access points cannot be aligned, it is desirable to have them offset so potential left turn paths do not cross and [AASHTO Case F Sight Distance](#) is accommodated.
6. The minimum distance between the ends of adjacent median openings is 300' on local streets and collectors and 400' on minor arterials and principal arterials, with greater distances preferred on Commuter Corridors and other roadways where vehicle throughput is highly prioritized, as determined by the City Engineer. See [FIGURE 7.5.100](#).

**FIGURE 7.5.100 Median Opening Spacing**



7. Only one road or driveway on each side of the roadway shall be served by the median opening. Where a property line falls within the median opening area, a common drive serving both properties shall be utilized.
8. A median opening will not be created or approved automatically because it meets the spacing requirements. The type of development, internal circulation and traffic operating conditions (existing or projected) on the street shall also be considered.
9. Consolidation of median openings should be considered during roadway reconstruction projects.

#### **7-5(l)(7)(ii)(c) Design Considerations**

1. Approval by the New Mexico Department of Transportation is required for all median openings along state-owned and maintained roadways.
2. The construction of appropriate left-turn lanes must be included with any new median opening. The length of the turn bay approaching the median opening shall allow for anticipated queueing needs.
3. See [7-5\(l\)\(7\)\(iii\)](#) for Turn Lane Design guidelines.
4. All median opening designs must address drainage needs.

#### **7-5(l)(7)(ii)(d) Median Opening Requests**

1. Median cuts require approval by the City Engineer.
2. A work order shall be obtained for construction. Work orders require engineered plans and may be obtained from DRC. Construction is the responsibility of the applicant.

- Depending on the size of the development, a traffic scoping report or traffic impact study may be required for a median opening to be created. See the [Article 7-6 Traffic Studies](#) for additional information.

### 7-5(I)(7)(iii) [Turn Lanes](#)

#### 7-5(I)(7)(iii)(a) [Definition and General Provisions](#)

- Separate turn lanes expedite the movement of through traffic, increase roadway capacity, permit the controlled movement of turning traffic, and promote the safety of all traffic.
- Turn lanes for right and left turns into a driveway or street may be necessary for safety and capacity reasons, where roadway speeds and traffic volumes are high, or if there are substantial turning volumes.

#### 7-5(I)(7)(iii)(b) [Turn Lane Warrants](#)

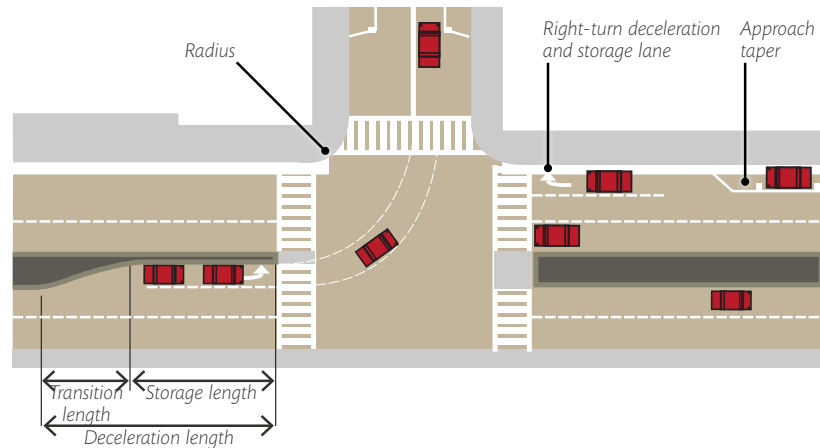
- A turn lane or a taper is required on streets where the Turn Lane Warrants ([TABLE 7.5.62](#)) are exceeded in the AM or PM peak. At locations that do not exceed the criteria, the City Engineer may still require a turn lane or taper to address known safety concerns.
- The City may require additional turn lanes and tapers or other improvements when it believes that the absence of such improvement will create an unsafe condition.
- Left-Turn lanes shall be required if a driveways/access points utilizing a median opening is constructed. The turn lane shall provide for both the storage and deceleration of turning vehicles, where feasible.
- Additional right-of-way for turn lanes, deceleration lanes, or tapers may need to be dedicated as determined by the City Engineer.

<b>Left Turn</b>		<b>Right Turn</b>	
<b>Design Speed</b>	<b>Turning Volume per Hour</b>	<b>Design Speed</b>	<b>Turning Volume per Hour</b>
<b>25</b>	50	25	60
<b>30-40</b>	40	30-40	50
<b>45</b>	30	45	45

#### 7-5(I)(7)(iii)(c) [Turn Lane Design](#)

- Design elements, which make up a turn lane, are shown in [FIGURE 7.5.101](#).

FIGURE 7.5.101 Turn Lane Design Elements

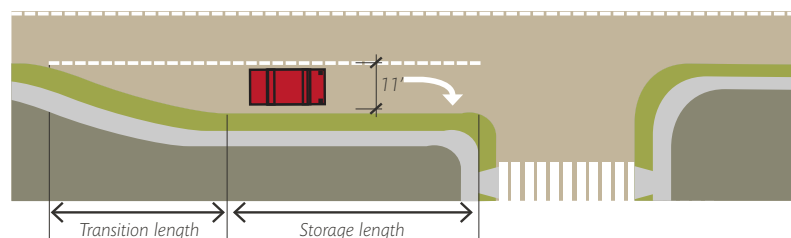


2. The design of turn lanes are based primarily on the following:
  - a. The length required for safe deceleration at which drivers will turn into the driveway or side street after traversing the deceleration lane.
  - b. The amount of vehicular storage that will be required.
3. The total length of the turn lane and taper should accommodate storage requirements plus deceleration and taper. If this is not feasible, the criteria below should be followed:
  - a. Include the transition length in the deceleration length requirement.
  - b. Assume that vehicles slow down to 10 mph below the roadway speed limit before entering the auxiliary lane and calculate deceleration needs based on this speed.
  - c. Calculate deceleration to a turning speed of 15 mph rather than a full stop (more applicable to right turns).
  - d. If none of the above is feasible, the lanes should accommodate the 95th percentile queue length.
4. Turn lanes should be 11 feet in width; however, the lane width may be adjusted to be compatible with the adjacent roadway lane width. In no event shall the turn lane width be less than ten feet.

**7-5(I)(7)(iii)(d) Right-Turn Lane Design**

See [FIGURE 7.5.102](#) for right-turn lane design elements and [TABLE 7.5.63](#) for the minimum lane length and turn lane transition requirements.

FIGURE 7.5.102 Right-Turn Lane Design Elements



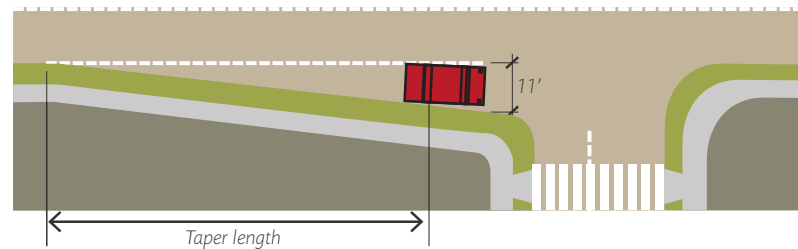
Design Speed of Roadway	Minimum Storage Length	Lane Transition Length
< 35	240'	150'-150' Reverse Curve
35 - 40	240' - 350'	300'-150' Reverse Curve
45 - 50	350' - 405'	600'-300' Reverse Curve

The required lane length values assume the roadway is on a two percent or less vertical grade. Longer deceleration lengths may be required on downgrades greater than two percent. Required lane length assume a 15 mph speed differential.

**7-5(I)(7)(iii)(e) Right Taper Design**

1. The use of tapers in lieu of dedicated right-turn lanes is strongly discouraged and requires approval of the City Engineer.
2. See [FIGURE 7.5.103](#) for right-turn lane design elements and [TABLE 7.5.64](#) for the minimum lane length and turn lane taper requirements.

**FIGURE 7.5.103 Right Taper Design Elements**



Design Speed of Roadway (MPH)	Required Taper
30 - 40	8:1 Taper
45 - 50	15:1 Taper

**7-5(I)(7)(iii)(f) Left-Turn Lane Design**

1. Where traffic is to be controlled by a traffic signal, the turn lane should be of sufficient length to store the turning vehicles and clear the equivalent lane volume of all other traffic on the approach, where feasible.
2. This length is necessary to ensure that full use of the separate turn lane will be achieved and that the queue of the other vehicles on the approach will not block vehicles from the turn lane.
3. See [TABLE 7.5.65](#) for the minimum left-turn lane transition length requirements.

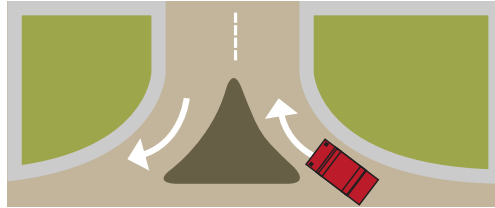
**TABLE 7.5.65 Minimum Left-Turn Lane Transition Length**

Design Speed of Roadway (MPH)	Lane Transition
< 35	150'-150' Reverse Curve
35 - 40	300'-150' Reverse Curve
45 - 50	600'-300' Reverse Curve

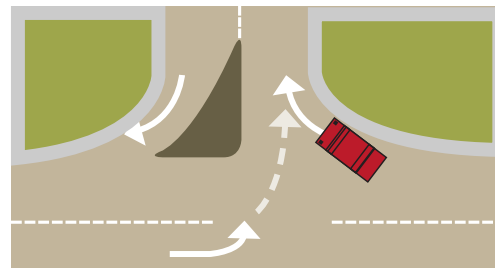
**7-5(l)(7)(iv) [Restricted Turning Movements](#)**

Restricted right and/or left turn movements may be required based upon factors such as one way roadways or the necessary restriction of movements at a drive at the discretion of the City Engineer. See [FIGURE 7.5.104](#) through [FIGURE 7.5.109](#) for illustrative examples of restricted turning movements.

**FIGURE 7.5.104 Right-In / Right-Out**



**FIGURE 7.5.105 Right-In / Right-Out and Left-In**



**FIGURE 7.5.106 Right-In / Right-Out and Left-Out**

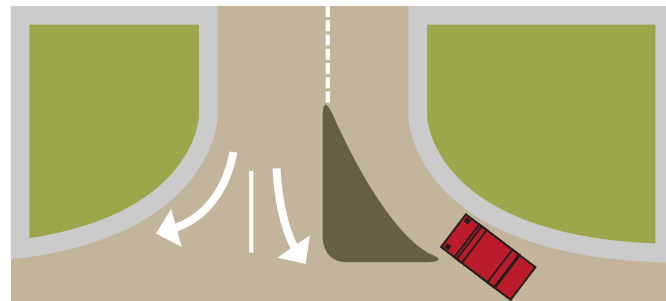


FIGURE 7.5.107 Restricted Median - Left-In Only

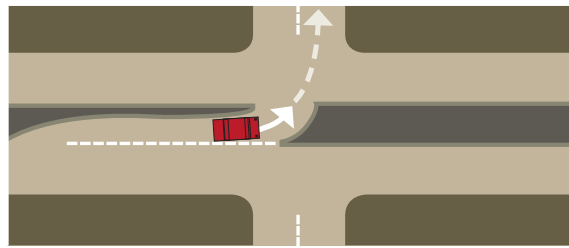


FIGURE 7.5.108 Restricted Median - Left-In and Left-Out on One Side

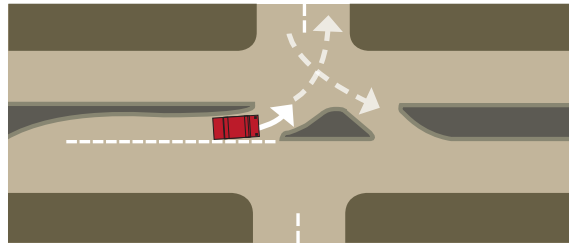
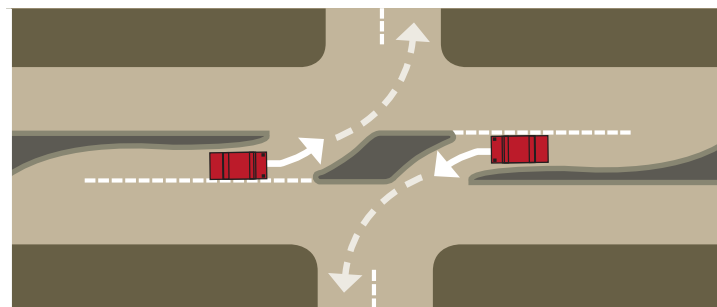


FIGURE 7.5.109 Restricted Median - Left-In Both Sides

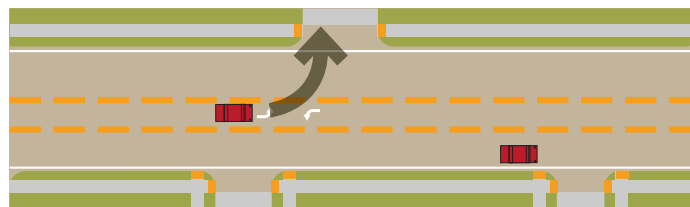


### 7-5(I)(7)(v) [Two Way Left-Turn Lanes](#)

#### 7-5(I)(7)(v)(a) *Definition and Appropriateness*

1. Two-way left-turn lanes (TWLTL) are continuous center lanes that allow motorists traveling in both directions to pull out of through lanes and into a shared lane for left turns. TWLTL offer spatial separation between opposing lanes of traffic and provide additional roadway capacity without adding general purpose lanes in each direction.

FIGURE 7.5.110 Two Way Left Turn Lane



2. TWLTL are most appropriate in locations with a high degree of land access, including a high intersection density and a large number of driveways, and

where turning movements and business access on both sides of the street are desired.

3. TWLTL are also appropriate where mid-block entrances are too close together to create dedicated turn lanes or turn bays.
4. Locations with few driveways or intersections are better served by medians and dedicated turn lanes.
5. TWLTL are particularly appropriate for preserving roadway capacity in the application of a road diet where a four or six-lane roadway is converted to a two or four-lane facility with a continuous center turn lane. TWLTL are not appropriate for locations with traffic volumes above 30,000 vehicles per day.

#### **7-5(I)(7)(v)(b) Design Considerations**

1. The width of TWLTL shall be 12'-14' as measured from the middle of the striping on either side of the turn lane.
2. TWLTL can create impediments for pedestrians as they add to crossing distance and may be incompatible with median refuge islands at mid-block crossings.
3. There should be no more than two through lanes in each direction adjacent to a TWLTL.
4. TWLTL can lead to conflicting left-turn paths if driveways are poorly spaced and located. This situation may require having raised medians in these areas to define left turn pockets and, or right-in right-out restrictions.

## **Part. 7-5(J) Local Streets**

This section provides guidance regarding the classification and design of local streets, private streets, stub streets, cul-de-sac, and single access to subdivisions. Local streets shall be designed to discourage high-speed driving and to support walking.

### **Section. 7-5(J)(1) Local Street Classifications**

1. **Access Local** – Access Local streets are loop streets, cul-de-sacs, and short segments that provide connections to other streets. Access Locals are not continuous for more than 1 or 2 blocks. Anticipated average daily traffic (ADT) for an Access Local street are 250 vehicles per day or less.
2. **Normal Local** – Normal Local streets direct traffic to Major Local streets or may connect directly to collectors and arterials. Streets with anticipated ADT from 250 to 1000 vehicles per day are classified as Normal Local streets.
3. **Major Local** – A Major Local street conveys traffic from other local streets to collector or arterial streets. The intent of Major Local streets is that sufficient space is available for two vehicles to travel unimpeded in opposite directions at the same time. Streets with an anticipated ADT of 1000 or greater are classified as Major Local streets.



FIGURE 7.5.111 Local Street Classification

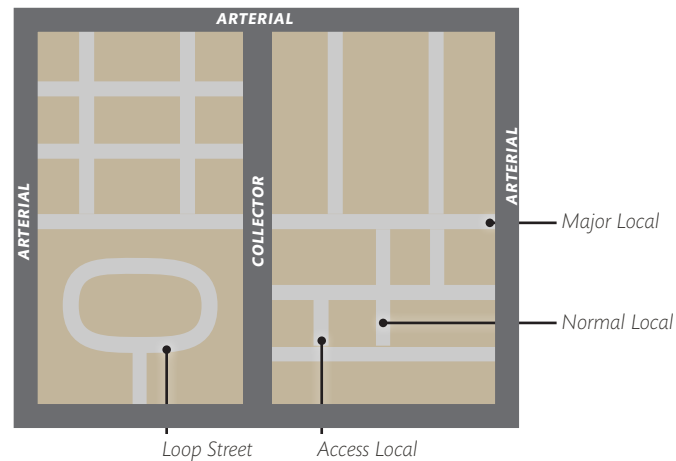


TABLE 7.5.66 Average Weekday Traffic Parameters for Local Streets

Street Type	Average Daily Traffic (ADT)
Access Local	Less than 250
Normal Local	250 ADT 1000
Major Local	Greater than 1000

7-5(J)(1)(i) [Trip Generation for Local Street Classification](#)

A trip generation and distribution exhibit is required to classify new local streets. The traffic volumes are to be determined based upon trip generation characteristics and the anticipated distribution of trips. See [TABLE 7.5.67](#) for the assumed ADT generated on local streets. Additional information regarding trip generation and traffic studies are located in the traffic calming section.

TABLE 7.5.67 Average Daily Traffic Generation for Local Streets

Type of Development	ADT per Unit
Single Family	10
Apartment/ Townhouse	6
Non-Residential or Mixed Use	Consult current ITE Trip Generation Manual

## Section. 7-5(J)(2) Local Street Design

### 7-5(J)(2)(i) [Local Street Layout](#)

1. Local Street connectivity shall be consistent with standards in [Article 7-5 Design Standards](#) and the [Metropolitan Transportation Plan Long Range Transportation System \(LRTS\) Guide](#).
2. Block lengths shall be designed as required in [Article 7-5 Design Standards](#).
3. Block lengths of local streets in residential areas shall be no longer than 600 feet.

### 7-5(J)(2)(ii) [Local Street Design Characteristics](#)

1. See [TABLE 7.5.68](#) for street design requirements for local streets.
2. Pavement widths for streets adjacent to schools, within 150 feet of arterial or collector streets, and adjacent to large neighborhood parks should be designed to the larger end of the range of the “All Other Areas” categories.
3. Three vehicle lanes may be provided as needed within 150 feet of intersections with collector or arterial streets, with two lanes for vehicles exiting and one lane for vehicles entering the Major Local street.
4. Right-of-way width requirements for extensions of existing roadways may be adjusted by the City Engineer if necessary to match existing right-of-way on the same street or to conform to drainage and/or landscaping requirements.
5. Bicycles may share the roadway on local streets. For additional information about bicycle lanes and bicycle routes, see [Part. 7-5\(F\) Bikeways and Trails](#).
6. On-street parking is generally permitted on local streets, though on-street parking areas do not have to be designated (i.e. pavement markings, and signage), and additional right-of-way and pavement width are not required.
7. Bicycle lanes and designated on-street parking are discouraged on Access Local and Normal Local streets.
8. Additional road elements that may be added to the cross section for Major Local streets, depending on the context and location, include additional turning lanes, medians, bicycle lanes, designated on-street parking, and additional planting areas to accommodate large trees.
9. Intersections involving two local streets are generally served by stop or yield-sign controls or neighborhood traffic circles.
10. See the following sections for additional guidance on street element design:
  - a. [Part. 7-5\(E\) Pedestrian Facilities](#) for guidance related to Pedestrian Facilities
  - b. [Part. 7-5\(F\) Bikeways and Trails](#) for Bicycle Facilities
  - c. [Part. 7-5\(H\) On-Street Parking](#) for On-street Parking
  - d. [Section. 7-5\(I\)\(6\)](#) for Intersection Design
  - e. [Section. 7-5\(I\)\(7\)](#) for Medians and Turn Lane Design

TABLE 7.5.68 Local Street Design Standards									
Corridor Type	Location	Design Speed (MPH)	Required Elements					Optional Elements	
			ROW Width (Min.)	Frontage Zone	Sidewalk Width	Landscape / Buffer Zone	Roadway Width (From curb face to curb face)	Designated Parking (Min.)	Median (Min.)
Access Local	City Wide	15-25	44'-46'	0	5'	4'	26'-28'	N/A	N/A
Normal Local	Single Family Residential Areas	18-25	48'-52'	0	5'	5'	28'-32'	N/A	N/A
	All Other Areas	18-25	48'-61'	1-2.5'	5'	5'	26'-36'	N/A	N/A
Major Local	Single Family Residential Areas	18-25	48'-58'	0	5'	5'	28'-38'	8'	4'-14'
	All Other Areas	18-30	50'-73'	1-2.5'	5'	5-6'	28'-46'	8'	4'-14'

FIGURE 7.5.112 Typical Access Local and Normal Local Street Cross Section

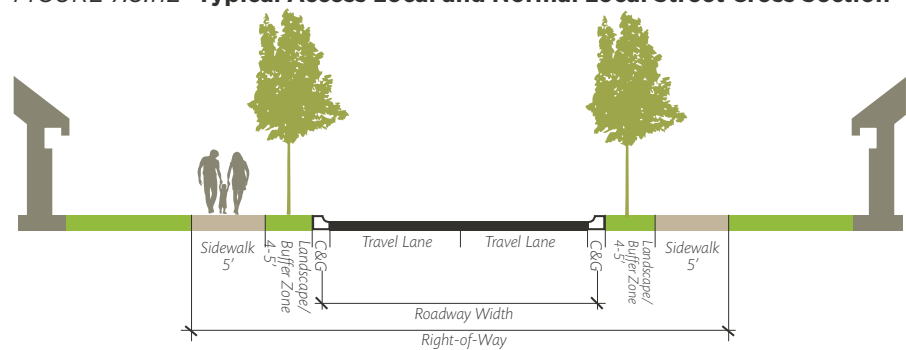


FIGURE 7.5.113 Major Local Street Cross Section with Designated Parking

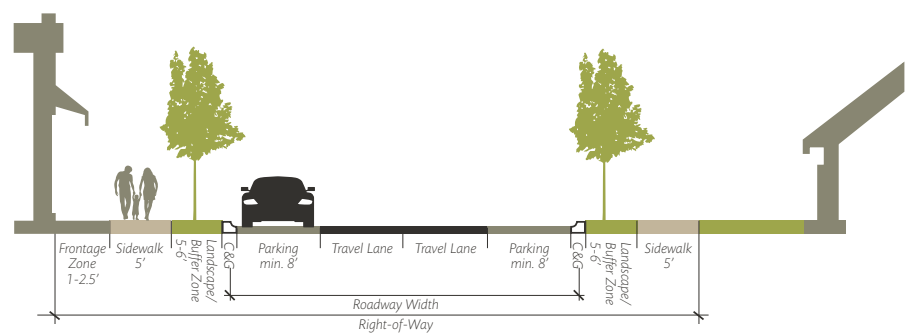
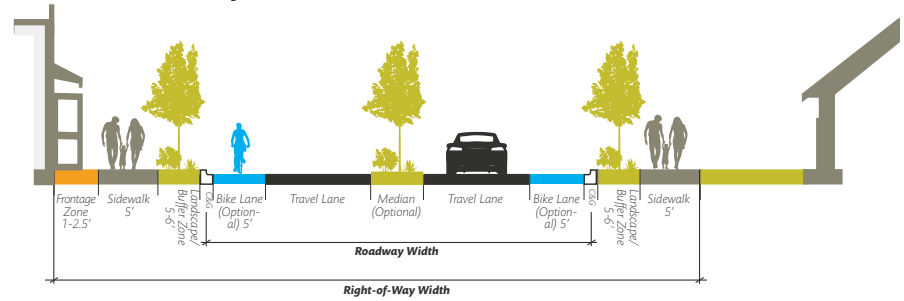


FIGURE 7.5.114 Major Local Street Cross Section with Bike Lanes



**Section. 7-5(J)(3) Stub, Cul-de-Sac, and Loop Street Criteria**

**7-5(J)(3)(i) Stub Streets**

1. Stub streets are the extension of a street past an intersection where a turnaround is not required. The maximum length is 150' measured from the centerline of the intersecting street to the end of the stub street.
2. See additional requirements in [IDO Section 5-3\(E\)\(1\)\(d\) Stub Streets and Cul-de-Sacs](#).
3. Stub streets shall follow design guidance for Access Local streets.

**7-5(J)(3)(ii) Cul-De-Sac and Hammer Head Streets**

1. Cul-de-sac and hammerhead streets are short streets intersecting another street at one end and terminating at the other end with a vehicular turnaround. [FIGURE 7.5.115](#) and [FIGURE 7.5.116](#) show typical dimensions.
2. See the [IDO Section 5-3\(E\)\(1\)\(d\)](#) and [Article 7-5 Design Standards](#) for appropriate locations and restrictions.
3. Cul-de-sacs and hammer head streets shall follow design guidance for Access Local streets.
4. The maximum length permitted in a hammerhead or cul-de-sac street is as shown in [TABLE 7.5.69](#) and is measured from the centerline of the intersecting street to the center of the turnaround.

**TABLE 7.5.69 Maximum Cul-De-Sac Length**

Min. F-F Street Width*	Max. Cul-de-Sac Length (ft.)
20'	≤ 500
26'	≤ 600

\* Roadway width is measured from face of curb to face of curb.

FIGURE 7.5.115 Cul-De-Sac Dimensions

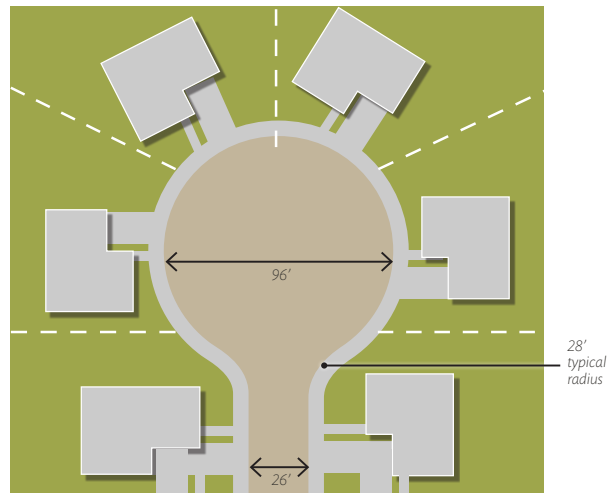
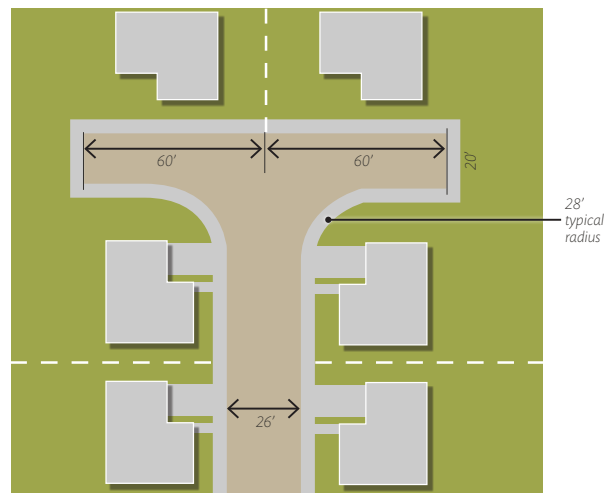


FIGURE 7.5.116 Hammerhead Dimensions



7-5(J)(3)(iii) [Loop Streets](#)

1. Loop streets shall have a maximum length of 1320', measured along a centerline, and shall be designated an Access Local street as described in [TABLE 7.5.68](#).
2. Loop streets shall be designed to prevent excessive speeds and have straight sections no longer than 600 feet.

**Section. 7-5(J)(4) Emergency Service Access to Local Streets**

1. Fire access roads shall be designed per the City of Albuquerque Fire Code.
2. The maximum number of dwelling units in a single or double family residential subdivision which can be served by a single point of access is 30.

3. Where a single access is combined with a strategically-located emergency access, the maximum number of units to be served is 100.
4. Projects that contain over 100 units must provide 2 non-emergency access points.
5. An emergency access shall have the following minimum criteria:
  - a. Width 20' with 28' radii at intersections with streets
  - b. Improved low maintenance surface (i.e. asphalt, concrete, or other approved driving surface capable of supporting 75,000 lbs.)
  - c. Breakaway gate for closure during non-emergency times

**Section. 7-5(J)(5) Private Streets**

1. All private streets providing access to eight (8) or more dwelling units shall be built per City of Albuquerque Standard Specifications, Standard Drawings, and DPM requirements for local streets. Any deviation must be approved by the City Engineer.
2. The use of private streets in the design of exclusive access to lots is limited by the following requirements:
  - a. The length, width, and permanent character of the private street must be suitably and legally defined by the plat establishing the lots being served. The lots served must abut or front the proposed private street.
  - b. The City Engineer shall determine that the proposed private street will always function as a street classified as Local Street and designed per [Section. 7-5\(J\)\(1\)](#) and that a public right-of-way would not better serve public purposes.
  - c. Easements for public utilities may be required.
  - d. Private streets shall be created by legal instrument that ensures future maintenance and operation as a private street.

**Section. 7-5(J)(6) Private Ways**

1. Private ways may be built for small subdivisions with eight (8) or less dwelling units.
2. Private ways shall be created by legal instrument that ensures future maintenance and operation as a private way. This may be done on a subdivision plat.
3. Private ways may be built per City of Albuquerque DPM, [Standard Specifications](#), and [Standard Drawings](#).
4. Private ways may be constructed of gravel or pavement.
5. The initial 25 feet behind the sidewalk on the intersecting street shall be paved, at a minimum, with 2 inches of asphalt on compacted subgrade as shown in the [Standard Drawings](#).
6. Table 3.10-5 shows the minimum design standards for Private Ways.
7. Table 3.10-6 shows the required access easement radii for right angle turn in the easement as well as the connection to the public street.

<b>TABLE 7.5.70 Private Way Design Standards</b>			
<b>Dwelling Units with Direct Access</b>	<b>Access Easement Width (Min)</b>	<b>Road Improvements (Minimum)</b>	<b>Pedestrian Improvements (Minimum)</b>
1	15'	15'	N/A
2 - 3	22'	22'	N/A

**TABLE 7.5.70 Private Way Design Standards**

Dwelling Units with Direct Access	Access Easement Width (Min)	Road Improvements (Minimum)	Pedestrian Improvements (Minimum)
4 - 8 (One Side Frontage)	29'	24'	One 5' Sidewalk
4 - 8 (Two Side Frontage)	34'	24'	Two 5' Sidewalks

**TABLE 7.5.71 Easement Radii for Private Access Easements**

Easement Width	Right Angle Turn within Easement	Connection to Public Street	Design Speed
15-22'	28' Inside Edge Easement Radius	None	15mph
29'-34'	50' Centerline Radius	20'	20mph

**Section. 7-5(J)(7) Entrance and Gate Requirements for Private Ways and Streets**

1. All gated communities must include a turnaround for visitors at the gate so that the vehicle does not stand or back into the public right-of-way.
2. Where a single gate is provided the minimum width shall be 20 feet. Divided streets shall provide a minimum 12 feet gate width.
3. Additional entrance and gate requirements may be required by the Fire Marshal.

**Part. 7-5(K) Off-Street Parking and Site Design**

This section provides guidance on site design and off-street parking layout. The overall site design shall accommodate all modes of transportation including automobiles, pedestrians, bicyclists, and motorcyclists. To facilitate efficient parking operations, the designer shall also consider the interface of the site with adjacent development areas.

**Section. 7-5(K)(1) General Provisions**

1. All sites and off-street parking areas shall be designed to comply with ADA/PROWAG standards.
2. The number of off-street, vehicle, bicycle and motorcycle parking spaces shall be provided as established in the [IDO Section 14-16-5-5, Parking and Loading](#).
3. Site design shall comply with design requirements and landscape buffers established by the [IDO Part 14-16-5, Dimensional Standards](#).
4. Parking and site layout shall be designed such that vehicles do not back into the public right-of-way, except single-family dwellings may back into local streets.

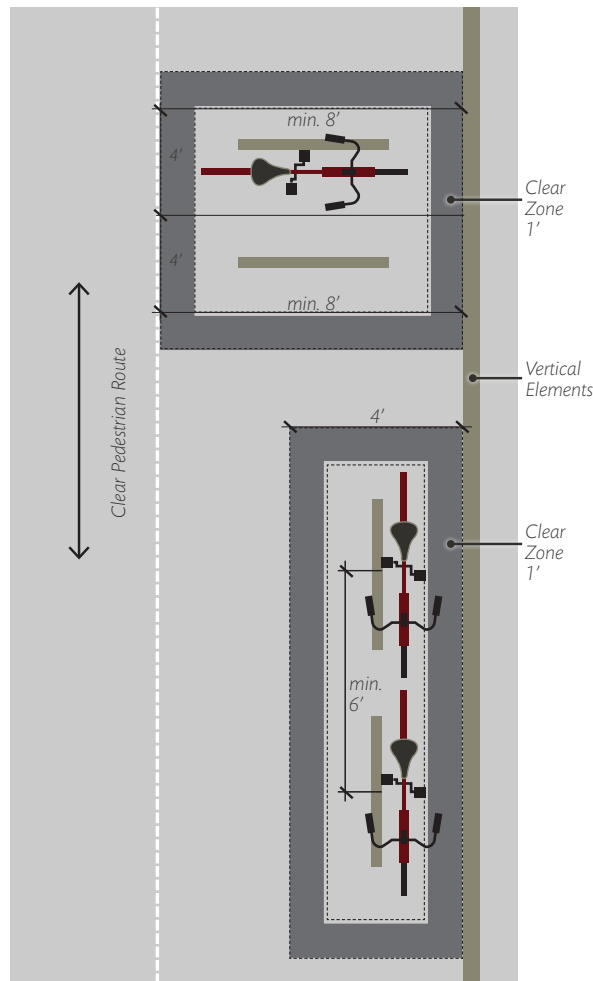


## Section. 7-5(K)(2) Bicycle Parking

Off-street bicycle parking location, layout and rack options vary widely. The following guidelines shall be considered when placing and designing bicycle parking areas and choosing rack options. Alternative rack design, placement, or installation methods not meeting the guidelines below may be considered and are reviewed on a case-by-case basis by the City Engineer.

1. All bicycle racks shall be designed according to the following guidelines:
  - a. The rack shall be a minimum 30 inches tall and 18 inches wide.
  - b. The bicycle frame shall be supported horizontally at two or more places. Comb/toaster racks are not allowed.
  - c. The rack shall be designed to support the bicycle in an upright position. See the [IDO Section 14-16-5-5\(E\)](#) for additional information.
  - d. The rack allows varying bicycle frame sizes and styles to be attached.
  - e. The user is not required to lift the bicycle onto the bicycle rack.
  - f. Each bicycle parking space is accessible without moving another bicycle.
2. Bicycle parking spaces shall be located in a well-lit area, visible from and, where feasible, located within 50 feet of the primary pedestrian entrance it serves. Bicycle rack placement shall meet the following placement requirements (also see [FIGURE 7.5.117](#) for direction on bicycle stall layout):
  - a. Bicycle parking shall be separated from vehicle parking areas and drive-ways by a barrier, such as a curb, rail, or bollard, or be located to minimize the possibility of vehicles striking parked bicycles.
  - b. Bicycle racks shall be placed in a designated area and shall not infringe upon the width of the required clear pedestrian access route (See [Part. 7-5\(E\) Pedestrian Facilities](#)).
  - c. Bicycle racks shall not be placed directly in front of entrances or in locations that impede pedestrian flow.
3. Bicycle racks shall be sturdy and anchored to a concrete pad.
4. A 1-foot clear zone around the bicycle parking stall shall be provided.
5. Bicycle parking spaces shall be at least 6 feet long and 2 feet wide.

FIGURE 7.5.117 Bicycle Parking Stall Layout Options



### Section. 7-5(K)(3) Motorcycle Parking

1. Motorcycle parking shall be a minimum 4 feet wide and 8 feet long (see [TABLE 7.5.72](#) and [FIGURE 7.5.118](#)).
2. Motorcycle parking spaces shall be located in a well-lit area that is visible from the primary building entrance on the site.
3. Motorcycle spaces shall be designated with a posted upright sign, either free standing or wall mounted. Each sign shall be no smaller than 12 by 18 inches and shall have its lower edge no less than 4 feet above grade.

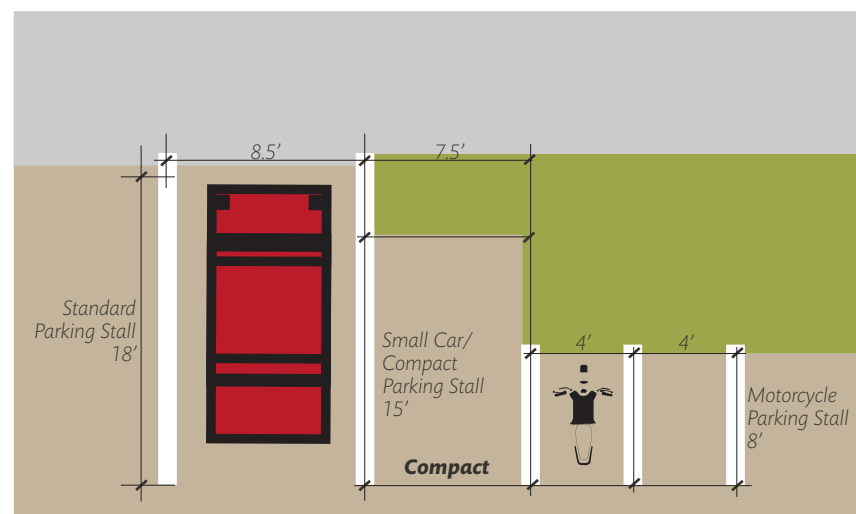
### Section. 7-5(K)(4) Standard and Small Car Parking

1. See [TABLE 7.5.72](#) and [FIGURE 7.5.118](#) for minimum parking stall dimensions.
2. Standard parking stalls shall be a minimum 8.5 feet wide and 18 feet long.
3. If the premises contains more than 20 spaces, one fourth of the spaces may be for small cars with dimensions of a minimum 7.5 feet wide and 15 feet long.
4. Compact parking spaces shall be identified by the words "**COMPACT**" on the pavement of each space.

5. Vehicles may overhang walkways and landscape areas as long as the overhang does not negatively impact the proposed landscape or reduce the required pedestrian access route to less than 4 feet wide.
6. The maximum overhang of parking spaces are 2 feet for standard parking spaces and 1.5 feet for small car spaces.
7. Vehicles shall not overhang public right-of-way or access ramps.
8. Parking spaces shall not cross over lot lines.
9. All parking spaces must be clearly identified through use of parking blocks, stripes, or other acceptable means.

Type of Parking	Min. Width	Min. Length	Max. Overhang
<b>Standard</b>	8.5'	18'	2'
<b>Small Car/ Compact</b>	7.5'	15'	1.5'
<b>Motorcycle</b>	4'	8'	N/A
<b>ADA Accessible</b>	8.5'	18'	2' Not acceptable at access ramps.

**FIGURE 7.5.118 Parking Stall Dimensions**

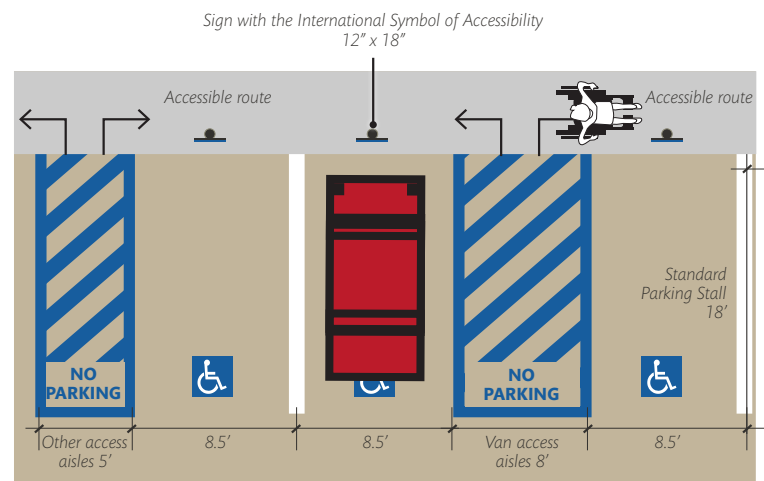


**Section. 7-5(K)(5) ADA Accessible Parking**

1. ADA accessible parking shall be a minimum 8.5 feet wide and 18 feet long (see [TABLE 7.5.72](#) and [FIGURE 7.5.119](#)).
2. Accessible parking spaces shall be located closest to the building entrances and dispersed among the various types of parking facilities and uses.
3. All accessible parking spaces shall include an access aisle.
4. Van access aisles shall be a minimum 8 feet wide; all others shall be a minimum 5 feet wide.
5. Access aisles shall not overlap the vehicular way.
6. Two parking spaces shall be permitted to share a common access aisle.
7. Each access aisle must adjoin a pedestrian access route.
8. Angled van parking spaces shall have access aisles located on the passenger side of the parking spaces.

9. The accessible route cannot be located at the rear of the parking stall or adjacent to a vehicle route.
10. Access aisles shall have blue, diagonal striping and shall have the words "NO PARKING" in capital letters, each of which shall be at least one-foot high and at least two inches wide, placed at the rear of the parking space so as to be close to where an adjacent vehicle's rear tires would be placed.
11. Accessible parking spaces shall have a clearly visible, blue, International Symbol of Accessibility painted on the pavement within the rear of the space.
12. A 12 by 18 inch sign with the International Symbol of Accessibility shall be provided at the head of each ADA accessible parking space. The sign must have the required language per [66-7-352.4C NMSA 1978](#) "Violators Are Subject to a Fine and/or Towing."
13. Where the total number of parking spaces provided is four or less, the International Symbol of Accessibility pavement marking is not required in the required accessible parking space.

**FIGURE 7.5.119 ADA Accessible Parking Stall and Access Aisle Dimensions**



### Section. 7-5(K)(6) Angled Parking

1. Angled parking stalls should accommodate a minimum 8.5' wide and 18' long vehicle space. See [FIGURE 7.5.120](#) and [TABLE 7.5.73](#) and for additional information on layout options and dimensions.
2. Parking barriers and/or extended shy zones are desirable to ensure vehicles with long rear overhangs do not intrude into the required clear pedestrian access route.

FIGURE 7.5.120 Dimensions for Angle Parking

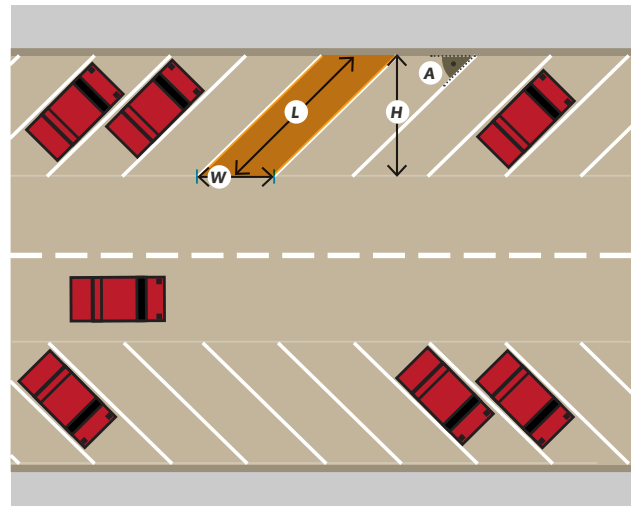


TABLE 7.5.73 Dimensions for Standard Angle Parking

Angle (A)	Stall Length (L)	Stall Width (W)	Stall Depth (H)	Drive Aisle (D)
30°	32.7'	17'	16.4'	11'
45°	26.5'	12'	18.7'	11'
60°	22.9'	9.8'	19.8'	15'
75°	20.3'	8.8'	19.6'	22'
90°	18'	8.5'	18'	24'

TABLE 7.5.55 Dimensions for Compact Angle Parking

Angle (A)	Stall Length (L)	Stall Width (W)	Stall Depth (H)	Drive Aisle (D)
30°	28.0'	15'	14.0'	11'
45°	22.5'	10.6'	15.9'	11'
60°	19.3'	8.7'	16.7'	15'
75°	17'	7.8'	16.4'	22'
90°	15'	7.5'	15'	24'

### Section. 7-5(K)(7) Pavement of Parking Areas

Parking areas shall be paved per the following standards:

1. Pavement shall be maintained level and serviceable.
2. Where a site has four (4) or more off-street parking spaces which require access off of an alley, the full width of the alley shall be paved from the parking access drive to a street, per the *City Standard Drawings*.
3. Designated accessible parking spaces and pedestrian pathways must be paved with a minimum 2-inch asphalt pavement over a 4-inch compacted subgrade or equivalent per City of Albuquerque standards to ensure compliance with federal guidelines.
4. For additional requirements and information of acceptable pavement materials see *Part. 7-5(C) Pavement Design*.

### Section. 7-5(K)(8) Curbing in Parking Areas

1. Curbing should be installed to delineate landscape, parking, and pedestrian ways and identify points of access.
2. Parking areas shall have barriers to prevent vehicles from extending over public sidewalk, public right-of-way, or abutting lots.
3. For additional requirements see [Part. 7-5\(D\) Curb and Gutter](#).

### Section. 7-5(K)(9) Grading in Parking Areas

1. The maximum grades in parking areas should not exceed 8%.
2. For major circulation aisles and adjacent to major pedestrian entrances, the grade shall be 5% or less.
3. ADA accessible parking spaces, access aisles, and access routes shall not exceed 2% in any direction.
4. Curb ramps shall not extend into the ADA accessible parking access aisles.

### Section. 7-5(K)(10) Sidewalk Connections

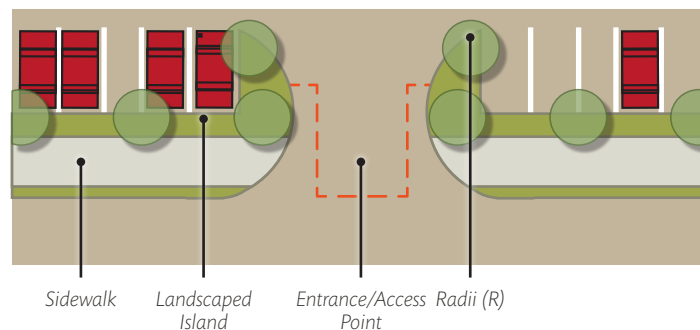
A separate pedestrian access route, referred to as a private walkway, shall be included connecting the public sidewalk to the buildings within the development. For additional requirements, see [Part. 7-5\(E\) Pedestrian Facilities](#) and [IDO Section 5-3\(D\)\(3\) On-site Pedestrian Connections](#).

### Section. 7-5(K)(11) Site Access

Parking lot access shall be designed to reduce conflicts with pedestrians and vehicular traffic and allow efficient ingress and egress of a parking area. See [Part. 7-5\(B\) Site Access Points](#) for additional site access requirements.

1. Adequate turning radii and queuing areas shall be maintained to provide continuous flow of traffic.
2. The design of the site access point should not impede pedestrian circulation and should facilitate efficient movement of pedestrians across the site access area.
3. Landscaped islands at the site access point may be provided to create a buffer and allow an adequate turning area.
4. At the site access point, a 15-foot radii should be used where only cars are to be accommodated.

FIGURE 7.5.121 Site Access Design



**Section. 7-5(K)(12) Fire and Emergency Access**

Provision for access by fire and emergency vehicles shall be in accordance with the Fire Code.

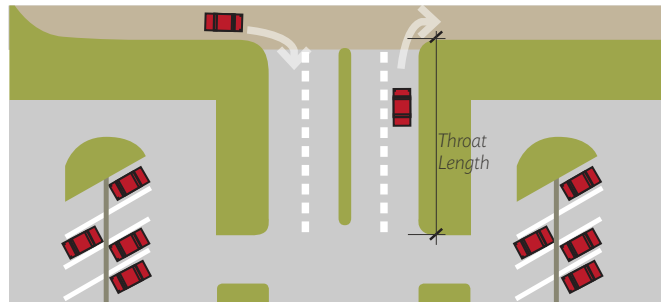
**Section. 7-5(K)(13) Solid Waste Access**

Refuse vehicle maneuvering shall be contained on-site. The refuse vehicle shall not back into the public right of way.

**Section. 7-5(K)(14) Access Throat Length and Queuing**

1. For all new development projects, queuing needs and the number of lanes for site access shall be evaluated.
2. The location of any access aisle shall preserve the queuing area for peak traffic generation periods.
3. [TABLE 7.5.74](#) shall be used to determine the access point throat lengths necessary to make adequate provisions for queuing.
4. For those land uses which are not represented, comparable lengths should be established based on traffic generation characteristics contained in the [ITE publication Trip Generation](#).

**FIGURE 7.5.122 Throat Length**

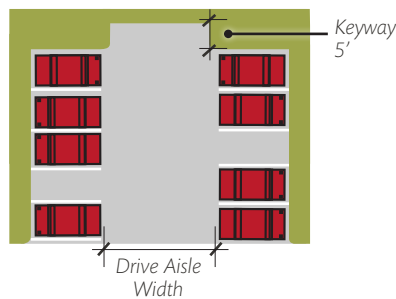


<b>TABLE 7.5.74 Minimum Throat Length</b>			
<b>Land Use</b>	<b>Size of development (ft<sup>2</sup>)</b>	<b>Collector (ft)</b>	<b>Arterial (ft)</b>
<b>Light &amp; Heavy Industrial</b>	<100,000	25	50
	100,000-500,000	50	100
	>500,000	100	150
<b>Commercial Development</b>	>200k	25	50
	100k-200k	50	75
	50k-100k	75	100
	<50k	100	125
<b>Multifamily (units)</b>	<100	25	50
	100-200	50	75
	>200	75	100

### Section. 7-5(K)(15) Site Layout and Circulation

1. Parking areas must provide internal circulation with a logical pattern that the driver can easily understand and follow.
2. The parking lot area should allow efficient movement of vehicles, bicyclists, and pedestrians.
3. Circulation shall be designed to avoid conflicts between vehicular, bicycle, and pedestrian traffic.
4. The parking layout should provide continuous flow of traffic through the lot.
5. Where a large number of compact parking spaces are utilized, these spaces should be spread throughout the parking area instead of being clustered in one area.
6. A 5 ft. keyway is required for dead-end parking aisles (see [FIGURE 7.5.123](#)).

**FIGURE 7.5.123 Keyway in Parking Area**



7. The minimum drive aisle dimensions are shown in [TABLE 7.5.75](#)

<b>TABLE 7.5.75 Minimum Drive Aisle Width</b>	
<b>Drive Type</b>	<b>Minimum Drive Aisle Width</b>
Two Way Traffic	22'
Main Circulation Road	24'
Fire Lane* Fire Marshall may require additional width adjacent to tall buildings	20'

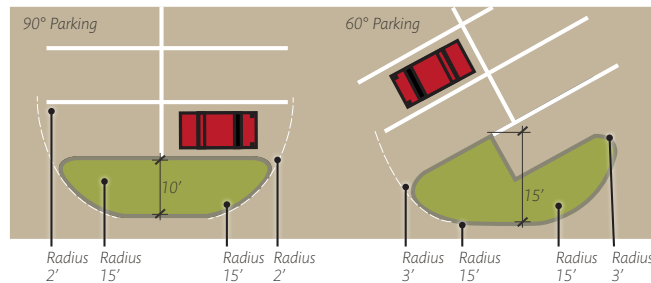
8. See additional requirements in [IDO Section 5-5\(F\) Parking Location and Design](#).

### Section. 7-5(K)(16) Parking Islands

1. In parking areas of 50 spaces or more, the ends of parking aisles shall be defined by parking islands. These islands define the parking stalls and provide adequate radii for vehicle turns and visibility.
2. Where the design vehicle is a passenger car, the radius should be 15 feet (see [FIGURE 7.5.124](#)).
3. Where the aisles will function for deliveries by larger trucks, refuse, and/or fire vehicles, a 25' radius or larger should be used.



FIGURE 7.5.124 Parking Islands



### Section. 7-5(K)(17) Service Areas

1. Service areas and service vehicle circulation requirements shall be accommodated in the site layout.
2. Site layout shall consider the circulation, backing, and storage requirements of the expected design vehicle.
3. Truck ramps, refuse/compactors, and similar facilities should be separated from the circulation aisles.
4. Visibility for parking and drive aisles shall be maintained in service areas.
5. Service vehicles shall not back into or from the public right of way

### Section. 7-5(K)(18) Signage & Striping

1. Adequate signing and striping shall be incorporated into the design of the parking area to convey to the motorist the proper use of the facility.
2. All one-way drives shall have "One Way" and "Do Not Enter" signage and pavement markings.

### Section. 7-5(K)(19) Drive-Through Facilities

1. Drive-through facilities shall be designed in accordance with requirements established by the [IDO Section 14-16-5-5\(I\)](#).
2. Drive-through queuing characteristics shall be accommodated in the site design.
3. Queuing of drive-through facilities should not interfere with either the access to the site, parking and circulation aisles, or the public right-of-way.
4. Each stacking space in the queuing lane shall be 20 feet long.
5. Minimum queuing lane widths are 12 feet minimum with a 25-foot minimum radius (inside edge) for all turns. A 15-foot radius may be used with an increase in lane width to 14 feet.
6. Uses not specified in the [IDO 14-16-5-5\(I\)](#) shall feature the queue lengths associated with a similar use, as approved by the City Engineer.

### Section. 7-5(K)(20) **Layout of Large Parking Areas**

1. In large developments, with more than 400 parking spaces, a 24-foot wide circulation roadway shall be established to accommodate two-way traffic and emergency vehicles, and to facilitate loading and unloading activities.
2. No parked vehicles shall back into the circulation roadway.
3. The maximum drive aisle length is 400 feet, with 300 feet desired, to discourage excessive vehicular speeds. Design which introduces curves and/or breaks in the parking lot pattern should be used to help control speeds.

### Section. 7-5(K)(21) **Traffic Circulation Layout Requirements**

1. The TCL site plans are required for commercial and institutional buildings, multi-family residential buildings, and commercial additions of 500 square feet or more. Information about TCL submittal requirements can be obtained from the [City website](#).
2. The traffic circulation layout must be stamped, signed, and dated by an engineer or architect licensed in the state of New Mexico.

## **Part. 7-5(L) Traffic Calming**

### Section. 7-5(L)(1) **Neighborhood Traffic Calming**

The Department of Municipal Development operates the City of Albuquerque [Neighborhood Traffic Management Program \(NTMP\)](#). The purpose of the program is to address speeding and cut-through traffic on local residential streets using a set of traffic-calming tools. These include physical tools, such as lane narrowing, turn restrictions, curb bulb-outs, and speed dips, as well as non-physical tools like radar speed signs and targeted enforcement. Further information about available strategies can be found in the Traffic Calming Toolkit, <http://www.cabq.gov/traffic>

Application process, warrants, and the procedure for implementing traffic calming requests can be found in the [Neighborhood Traffic Management Program \(NTMP\): A summary of Traffic Calming Policy and Neighborhood Traffic Management Strategies](#), <http://www.cabq.gov/traffic/>.

Some traffic calming tools (speed humps, bulb-outs, lane narrowing, etc.) will reduce the hydraulic capacity of streets and may cause flows to exceed curb height. A hydraulic analysis of street flows may be required by the city hydrologist prior to construction.

### Section. 7-5(L)(2) **Speed Management on Major Roads**

Traffic calming, or speed management techniques, may be considered on collectors and arterial roadways depending on the location, the desired function of the roadway, roadway geometry including considerations such as sight distance, and/or observed traffic characteristics. Speed management on major roads should be implemented in a targeted manner since collectors and arterials also play a role in regional mobility and must balance the needs of all users. Any improvements shall consider Level of Service as well as the Modal Priority

Matrix as contained in the Comprehensive Plan, and is subject to approval from the City Engineer.

### 7-5(L)(2)(i) Definition

Speed management involves elements along a roadway that physically narrow the road and improve visual awareness among motorists. These techniques are intended to discourage high speed travel in locations with high levels of pedestrian activity. Beyond reduced speed and improved safety, benefits include additional space in the pedestrian realm for utilities, street furniture, and other amenities.

### 7-5(L)(2)(ii) Appropriate locations

Though some speed management techniques, such as signal coordination and lane width reductions, can be introduced in most contexts, the introduction of certain speed management techniques depends on the location and context. In general, speed management techniques may be introduced in the following situations:

1. Within Comprehensive Plan-designated Centers
2. Near pedestrian generators, such as schools and retail centers
3. Along bicycle routes and bicycle boulevards
4. Along other Major Transit, Multi-modal, and Main Street corridors as appropriate

### 7-5(L)(2)(iii) Speed Management Toolkit

Provided below are general speed management techniques that may be appropriate along collector and arterial roadways. Speed management measures are most effective when used in combination, and must be accompanied by appropriate signage.

1. **Intersection geometry improvements** – Physical changes that narrow a roadway to encourage slower vehicle speeds and reduce the crossing distance for cyclists and pedestrians. Examples include curb extensions and median refuge islands. See the [NACTO Urban Street Design Guide](#) for curb extension concepts.
2. **Median refuge islands** - Technique used to narrow roads, provide visual prompts to motorists, and allow for shorter pedestrian crossings. See the Pedestrian Facilities section for guidance on median refuge islands and the application of curb extensions at intersections.
3. **Road diets** – A range of techniques to encourage slower travel speeds and create space for other users. Concepts are divided into two categories:
  - a. **Road reconfiguration** – *Redesign of roadways to produce narrower and fewer travel lanes and increase the space within the right-of-way allocated for bicyclists and/or pedestrians. Redesigns may include other features to reduce travel speeds, including on-street parking, signage, and street trees or landscaping. Road reconfigurations may be achieved through restriping and reallocation of roadway space or as part of a reconstruction project.*
  - b. **Restriping and narrowing of travel lanes** – *Approach that maintains the same number of travel lanes, but narrows general purpose lanes to create space to add or widen bike lanes, insert marked buffers, and/or widen sidewalks. Travel lanes may be reduced to 10-11' and protected turn lanes to 10'.*

4. **Traffic signal timing** – Technique that sets signals for a target speed and requires moderate travel speeds for drivers to hit each traffic light in succession.
5. **Signage and radar speed signs** – Use of signage and technology to improve awareness and provide motorists feedback on their travel speeds.
6. **Roundabouts** – Intersection design in which all movements are one-way. Roundabouts can reduce crash severity while decreasing overall delay. See the [Traffic Control Devices](#) element of the Intersection Design section for information on traffic circles and roundabouts.
7. **Vertical elements** – Design elements that cause motorists to slow down through deflection techniques such as chicanes or road narrowing medians, or vertical speed control elements such as speed humps, speed cushions, and speed tables (which may be applicable to streets outside of neighborhood contexts).

## Part. 7-5(M) Street Lighting

### Section. 7-5(M)(1) Roadway Lighting Criteria

#### 7-5(M)(1)(i) [Definition of Terms](#)

1. **LED** – Light Emitting Diode, a light source shown to have lower energy consumption and longer lifetime than incandescent light sources.
2. **IESNA** – Illuminating Engineering Society of North America
3. **IESNA RP-8** – IESNA provides recommended roadway design criteria in its document called [Recommended Practice 8, Roadway Lighting \(RP-8\)](#)
4. **LM-80-08** – IESNA Approved Method for Measuring Lumen Maintenance of LED Light Sources
5. **NEMA** – National Electrical Manufacturers Association
6. **Average Maintained Illuminance** – represents the output of the lamp and luminaire, after being reduced by maintenance factors (e.g., light loss depreciation and dirt depreciation); expressed in average-foot-candles (ft-cd or lux) for the pavement area.
7. **Light Loss Depreciation** – is defined as the decline in the light lumen that occurs as a lamp is operated over time.
8. **Luminaire Dirt Depreciation** – the process of dirt accumulating on luminaires, decreasing the total output of light and lowering the overall efficiency of the system
9. **Correlated Color Temperature (CCT)** – characteristic of visible light describing the color a light emits comparable to that of the light source.

#### 7-5(M)(1)(ii) [General Provisions](#)

1. The City of Albuquerque adheres to [IESNA RP-8](#) guidelines for roadway illuminance, uniformity ratios, and veiling luminance ratios. Also see [IDO Section 5-8, Outdoor Lighting](#) for more guidelines.
2. Low power LED lights shall be installed on all streets.
3. All streets shall be illuminated to Illumination Engineering Society (IES) standards. Street lights shall be located at all intersections, on cul-de-sac streets over 200' in lengths, at right angle turns, and at mid-block locations where block lengths exceed 500'.

4. Street Light electrical infrastructure wiring shall be aluminum with the standard aluminum label permanently affixed to the exterior of the street light pole above the electrical service hand-hole.
5. All street light poles shall be steel, aluminum, or other City approved and UL listed materials.
6. New wood and fiberglass poles are prohibited to be used for City assets.
7. [TABLE 7.5.76](#) shows the minimum average illuminance to be maintained in the City of Albuquerque.

<b>TABLE 7.5.76 Minimum Average Maintained Illuminance. <math>E_h</math></b>			
Pavement Classification	R1	R2 or R3	R4
$E_h$ (ft-cd)	1.4	2.0	1.8

*R1 = portland-cement concrete  
 R2 = asphalt, aggregate consists of minimum 60% gravel passing 3/8-in sieve  
 R3 = asphalt, rough texture (typical highway)  
 R4 = asphalt, smooth texture*

<b>TABLE 7.5.77 Minimum Average Maintained Illuminance</b>	
Pavement Classification	$E_h$ (ft-cd)
Portland-cement concrete	1.4'
Asphalt (aggregate minimum 60% gravel passing 3/8-in sieve) asphalt (rough texture-typical highway)	2.0
Asphalt (smooth texture)	1.8

9. [TABLE 7.5.77](#) lists the recommended ranges for the average maintained illuminance levels for various roadway classifications as defined by COA. The table is derived for all types of road surface classification.

<b>TABLE 7.5.78 Illuminance Method - Recommended Values</b>						
Roadway & Pedestrian Conflict Area		Pavement Classification (Minimum Maintained Average Values)			Uniformity Ratio	Veiling Luminance Ratio
Road	Conflict Area	R1 lux/ftc	R2 & R3 lux/ftc	R4 lux/ftc	$E_{avg} / E_{min}$	$L_{v,max} / L_{avg}$
Commuter Corridor	High	12.0/1.2	17.0/1.7	15.0/1.5	3.0	0.3
	Medium	9.0 / 0.9	13.0/1.3	11.0/1.1	3.0	0.3
	Low	6.0 / 0.6	9.0 / 0.9	8.0 / 0.8	3.0	0.3
Major Transit	High	8.0 / 0.8	12.0/1.2	10.0/1.0	4.0	0.4
	Medium	6.0 / 0.6	9.0 / 0.9	8.0 / 0.8	4.0	0.4
	Low	4.0 / 0.4	6.0 / 0.6	5.0 / 0.5	4.0	0.4
Local	High	6.0 / 0.6	9.0 / 0.9	8.0 / 0.8	6.0	0.4
	Medium	5.0 / 0.5	7.0 / 0.7	6.0 / 0.6	6.0	0.4
	Low	3.0 / 0.3	4.0 / 0.4	4.0 / 0.4	6.0	0.4

10. These illuminance guidelines are subject to the spacing to mounting height ratio.
11. The target spacing to mounting height (S/MH) ratio for highway, arterial, and collector streets is 3:5.

12. For local streets and alleys, pole heights and spacing will often be insufficient to achieve IES recommended illuminance levels without violating uniformity and veiling recommendations. The intent of these pole locations is to alert drivers to upcoming intersections and provide a source of orientation.

### **Section. 7-5(M)(2) New Lighting System Considerations**

1. Pole configurations and luminaires should be selected to distribute light in accordance with [ANSI/IES](#) recommendations for the most current Roadway and Street Lighting standards. See also the Department of Energy (DOE) [Model Specification for LED Roadway Luminaires](#) (MSSLC).
2. Luminaire mounting height (MH) should vary in proportion with road width (RW).
  - a. As a default, the RW/MH ratio may vary between 1.0 and 2.75. In these scenarios, with a unilateral pole configuration, the S/MH ratio must be  $\leq 5$ .
  - b. Higher RW/MH Ratios will need shorter S/MH Ratios, between 3 to 5. Different solutions are possible depending on luminaire photometric distribution types, arm lengths, over hang, and luminaire tilt.
  - c. Software calculations using IES files, lighting depreciation factors (LLF) to verify maintained lighting levels, and appropriate roadway reflectance values for luminance may be required for verification.

### **Section. 7-5(M)(3) Distribution Criteria**

#### **7-5(M)(3)(i) [Vertical Light Distribution](#)**

1. For residential areas, mixed-use and commercial areas, all luminaires must have a full cutoff luminaire light distribution with zero candelas (intensity) at an angle of 90 degrees or above, or a Cutoff luminaire light distribution where the candela per 1,000 lumens does not exceed 25 (2.5%) at an angle of 90 degrees or above.
2. By establishing the standards for lighting fixtures in residential, intermediate, and commercial areas, rear obtrusive light can be minimized.

#### **7-5(M)(3)(ii) [Lateral Light Distribution](#)**

1. LED luminaire manufacturers generally offer light distributions based on NEMA distribution types ranging from Type I to Type VII.
2. Roadway luminaires typically fall between Type II -Type V.
3. The selected optic type will depend on the specific configuration that the luminaire is deployed in.
4. Relevant variables include road width, pole spacing, and mounting height.
5. Light distributions for the same optic type may also vary from manufacturer to manufacturer.

### **Section. 7-5(M)(4) Correlated Color Temperature (CCT)**

1. A hierarchy of CCTs corresponding to roadway type and usage may provide benefits to citizens and tourists alike through improved wayfinding and ambience.
2. In general, lower traffic areas such as residential neighborhoods should receive warmer white (lower kelvin) luminaires, whereas higher traffic

areas (major roads, highways) should receive cooler white (higher kelvin) luminaires.

3. Exceptions may be made for specific locations, such as Historic Old Town or Hunning Highland.
4. Lower color temperatures should be given preference in order to comply with American Medical Association (AMA) and International Dark-Sky Association (IDA) recommendations.
5. CCT's above 4000K shall be avoided.
6. The CCT hierarchies listed below shall be deployed for similar visual perception goals:

Local/Residential	Collector/ Major Transit	Commuter Corridor
3000K	3500K	4000K

7. LED technologies and CCT availabilities and efficacies are routinely evolving. These standards should be revised in accordance with industry best practice.

### Section. 7-5(M)(5) **Luminaire Criteria**

Luminaires shall satisfy all system design criteria listed above. In addition, all luminaires should meet or exceed the following luminaire level criteria.

#### 7-5(M)(5)(i) Performance Criteria

1. Efficacy (lumens/Watt): > 90 lm/W
2. Color Rendering Index (CRI): > 65
3. Lumen Maintenance (L70): L70 > 50,000 hours as supported by [LM80](#) and [TM-21](#) documentation.
4. CCT: As specified in [ANSI C78.377](#)

**NOTE:** Adapted from ANSI C78.377.

Manufacture Rated Nominal CCT (K)	Allowable IES LM-79 Chromaticity Values	
	Measured CCT (K)	Measured Duv
3000	2870 to 3220	-0.006 to 0.006
3500	3220 to 3710	-0.005 to 0.007
4000	3710 to 4260	-0.005 to 0.007

#### 7-5(M)(5)(ii) Controls Criteria

1. Luminaire shall be fully prewired and shall incorporate an [ANSI C136.41](#) compliant 7-pin receptacle.
2. If a dimmable LED driver is specified, its 0-10V or DALI control wires shall be connected to the receptacle pads as specified in [ANSI C136.41](#); connection of the two remaining pads shall be by Supplier, as directed by Owner.

#### 7-5(M)(5)(iii) Identification Criteria

1. Luminaire shall have an external label per [ANSI C136.15](#).
2. Luminaire shall have an internal label per [ANSI C136.22](#)



#### 7-5(M)(5)(iv) Interference and Power Quality Criteria

1. Luminaire shall comply with [FCC 47 CFR part 15 interference criteria for Class A](#) (non-residential) digital devices.
2. (For residential areas) [FCC 47 CFR part 15 interference criteria for Class B](#) shall be required. Reference FCC 47 CFR 15.105.
3. Luminaire shall comply with section 5.2.5 (luminaires rated for outdoor use) of [ANSI C82.77](#) at full input power and across specified voltage range.

#### 7-5(M)(5)(v) Electrical Safety Testing Criteria

1. Luminaire shall be listed for wet locations by a U.S. Occupational Safety Health Administration (OSHA) Nationally Recognized Testing Laboratory (NRTL).
2. Luminaire shall have locality-appropriate governing mark and certification.
3. Luminaire shall meet the performance requirements specified in [ANSI C136.2](#) for dielectric withstand, using the DC test level and configuration.

#### 7-5(M)(5)(vi) Electrical Immunity Criteria

1. Luminaire shall meet the performance requirements specified in [ANSI C136.2](#) for electrical immunity.
2. Manufacturer shall indicate on submittal form whether failure of the electrical immunity system can possibly result in disconnect of power to luminaire.

#### 7-5(M)(5)(vii) Painted or Finished Surfaces Exposed to the Environment

1. Shall exceed a rating of six per ASTM D1654 after 1000 hours of testing per ASTM B117.
2. The coating shall exhibit no greater than 30% reduction of gloss per ASTM D523, after 500 hours of QUV testing at ASTM G154 Cycle 6.

### **Section. 7-5(M)(6) Street Lighting Development Build out Requirements**

1. In new subdivisions, the developer is required to adhere to the National Electrical Code (NEC) and the International Building Code (IBC) when designing streetlight infrastructure associated with the new development. This includes wiring, voltage drop method and circuit sizing.
2. The Developer shall install a PNM Metered Service for all street lighting to allow full measurement of all electrical usage for street lighting luminaires.
3. NEMA 3R -Electrical service disconnecting equipment shall be required to provide life safety to all future maintenance associated with the streetlight infrastructure.
4. Design load calculations shall be required along with permitting and code inspections on all new subdivision developments.
5. In new subdivisions, the developer submits a copy of the plat with required street lighting marked to Planning's Traffic Engineer.
6. Once approved by Traffic Engineer will then forwarded the street light installation plat to Public Service Company of New Mexico (PNM) for design of the street lighting system.



7. The Developer installs the street lights and in conjunction works with PNM on the installation of electrical service to the subdivision.
8. The Developer is responsible for charges PNM accesses on customer built / sales agreement contracts to energize subdivision."
9. In new subdivisions, the Developer is required to submit a (1) hard copy and (1) electronic copy of the final as-built plat (city owned street light facilities only) with required street lighting, junction boxes, termination points and wire sizing to Planning's Traffic Engineer.
10. The Developer will be required to submit a (1) hard copy and (1) electronic copy of the final as built plat of all facilities installed on behalf of PNM (including existing easements noted).
11. The Developer is fully responsible for the construction of the streetlight infrastructure as well as all coordination required with PNM for a completed project.
12. Street Light electrical infrastructure wiring shall be aluminum with the standard aluminum label permanently affixed to the exterior of the street light pole above the electrical service hand-hole.
13. All street light poles shall be metal, aluminum, or other approved UL listed materials. Wood poles are prohibited to be used for City assets.
14. The Developer shall follow PNM Electric Service Guide in the design and installation of all electrical power for all street light installations. [www.pnm.com/esq](http://www.pnm.com/esq)

## **Part. 7-5(N) Traffic Control and Development Requirements**

### **Section. 7-5(N)(1) Traffic Control & Phasing Plan**

1. A critical element to maintaining safe conditions during street construction activities includes traffic control plans and phasing of construction activities. All construction activities shall address these elements through a plan which will identify the phasing of construction activities and the necessary traffic control devices in accordance with the latest edition of the Manual on Uniform Traffic Control Devices.
2. Roadway projects often impede drastically on the pedestrian, bicycle and transit routes. Provisions shall be included in all traffic control and phasing plans for reasonable and continuous access to these modes of traffic.
3. The right-of-way for a street typically accommodates many different underground and overhead utilities. The designer of a construction project needs to coordinate design activities with the other users of the right-of-way including existing and future utilities. The traffic control and phasing plans need to incorporate provisions for these other users.
4. Construction activities within the right-of-way require an excavation permit. Prior to the issuance of the permit, plans must be submitted with appropriate approvals which define the construction activities, appropriate traffic control measure, and evidence of notification through the One Call System.

### **Section. 7-5(N)(2) Traffic Construction and Fees**

1. The Construction Coordination Section of the Department of Municipal Development is responsible for coordinating most activities conducted

- in the public right-of-way, including issuance of barricade and excavation permits, inspection of all barricaded sites etc.
2. During large City construction projects, special events, and during the holiday season, construction moratoriums are instituted to ensure safe and efficient road conditions for the traveling public. See the Construction Coordination Section for additional information.
  3. Restoration fees are required on any street which has been newly constructed or has received major reconstruction or maintenance within the past five years.

## **Part. 7-5(O) Naming of Streets**

1. The naming of streets within the City of Albuquerque and within its extra-territorial planning and platting jurisdiction shall follow the [Street Names Ordinance 6-5-1](#). The policy applies to all streets which normally provide primary access to abutting property, whether by public right-of-way or by private way.
2. The City Engineer shall approve every new or changed name of a street within its planning and platting jurisdiction.
3. Where a street is or clearly will be both within and outside of the City of Albuquerque, the City shall confer with other local governments and seek a mutually satisfactory name.

### **7-5(O)(2)(i) [Method of Naming](#)**

The following methods and requirements shall be used to name all streets in the City of Albuquerque.

1. By plat dedicating public right-of-way for an unnamed local or collector street, or by the continuation of a named principal or minor arterial; or
2. By the adoption of a surveyed street line with name pursuant to the [Future Street Line Ordinance 6-5-3 ROA 1994](#); or
3. By adoption of a resolution by the City Council concerning the name of a specific principal or minor arterial street.

### **7-5(O)(2)(ii) [Street Designations](#)**

1. New or the continuation of a principal and minor arterial as defined by LRTS shall be designated "Boulevard".
2. Local and collector streets which run essentially North-South shall be designated "Street" or "Drive".
3. Local and collector streets which run essentially East-West shall be designated "Road" or "Avenue".
4. Local street cul-de-sacs may be designated "Court" or "Place", depending on the length of the cul-de-sac. ("Place" to be used for cul-de-sacs at or near maximum length).
5. Circular turn-arounds having less than six (6) lots may not require a street name.
6. An additional street name may be required where the change in direction of the street is greater than 90 degrees in order to comply with the Street Addressing Ordinance.
7. In places where the appropriate street designation is not clear, the City Engineer shall determine the designation.

### 7-5(O)(2)(iii) Street Names

1. The name of a new street should be the name of an existing, nearby street which is essentially in line with it, unless the City Engineer finds that such name continuation would not be helpful to motorists searching for an address.
2. If this does not apply, new streets shall be named per the following policies:
  - a. *Grouping of names with similar content, such as: cities, trees, names, etc., is desirable.*
  - b. *Alphabetical sequences of street names, such as: Arizona St., California St., Carolina St., etc., is desirable.*
  - c. *Names with double meaning, or names difficult to spell or pronounce are usually undesirable.*
  - d. *Names already in use for streets in another area and not essentially in line with the new street are unacceptable.*
  - e. *Names of over 13 letters and spaces are unacceptable. (Street designations such as Blvd., Dr. and quadrant designations such as NE are not counted in the 13 allowed letters).*

### 7-5(O)(2)(iv) Procedure

1. To change the name of an existing street, a request is filed with the City Surveyor as the designee of the City Engineer,
2. For new streets the developer will apply for and submit to the City Surveyor, a preliminary plat for review and approval. The City Surveyor will accept the developer's proposal for street names which are consistent with the Street Name Ordinance, and the previous guidelines. The City Engineer reserves the right to name streets where the City Engineer finds that developer's name or designation is not consistent with City Policies and/or the public welfare.
3. Appeal of the City Engineer's decision is to the Environmental Planning Commission (EPC). The Planning Commission decision may be appealed to the City Council.

### **Section. 7-5(O)(1) Markings**

1. Street markings in accordance with the MUTCD and current City of Albuquerque standard drawings and specifications shall be included in the construction of new streets.
2. The layout of these markings need to be shown in the plans and included in the work to be performed by the contractor.

### **Section. 7-5(O)(2) Signage**

1. Signs shall be installed in accordance with MUTCD and current City of Albuquerque standard drawings and specifications in the construction of new subdivisions.
2. For new construction, the layout of these signs need to be shown in the plans and included in the work performed by the Contractor.
3. All signs are installed by the developer at the Developer's expense.
4. The developer of a subdivision pays a street name sign fee for each intersection at the time of application as set forth in the Subdivision of Land Regulations, IDO Section 14-16-5-4.

### Section. 7-5(O)(3) Traffic Signals

1. See [Section. 7-5\(I\)\(6\)](#) and [Part. 7-5\(L\) Traffic Calming](#) for design guidelines and signal warranting information. The determination of appropriateness and location of traffic signals shall be at the discretion of the City Engineer.
2. The latest edition of the [MUTCD](#) and current [City of Albuquerque](#) standard drawings and specifications shall be used to define the design of these elements. Where traffic signals may be warranted at a future date, the installation of a portion of the future signal elements including foundations, needs to be included in the construction of the streets.
3. Where signalization is not likely in the near future, only the underground conduit and pull boxes need to be constructed.

### Section. 7-5(O)(4) Barricades at Ends of Pavements Signage

1. A Type III barricade (per [MUTCD](#)) will be required at the end of any street pavement within or at the limits of a project regardless of the class of street involved or how soon additional pavement will be placed beyond the current project limits.
2. The only exception will be where the Traffic Engineer determines that the unpaved portion of the street beyond the project limits has been and will continue to be open to and used by through traffic.
3. The installation of the barricade must be shown on the plans and included as a part of the street improvements.

## ARTICLE 7-6 TRAFFIC STUDIES

### Part. 7-6(A) Background and Purpose

The City of Albuquerque requires that traffic impacts be considered as part of the development review process. There are two types of traffic analyses that may be required:

1. Traffic scoping form (TSF), which includes a basic overview of roadway and transportation conditions.
2. Traffic impact study (TIS), which requires an in-depth examination of the potential impacts of new development on nearby roadways.

The purpose of each document is to assess the changes to the transportation system resulting from a proposed development and to identify transportation improvements (i.e. mitigation measures) to be provided by the site developer to address the impacts of additional traffic associated with the development. This section clarifies the purpose and need of a TSF and a TIS, discusses when such analyses are required, as well as the expected structure and contents of a TIS report.

Traffic scoping forms and TISs vary in complexity based on the scale, location, and type of development, and are ultimately intended to ensure that new developments can be accommodated and integrated within the City's transportation system. Design solutions and mitigation measures should be appropriate for the situation, financially reasonable, and balance the needs for site access, through traffic, and the safety of all travelers.

Where a TIS is required, the City Traffic Engineer shall work with the project developer on the scope and parameters of the TIS and to review the findings of the report.

Traffic scoping forms and traffic impact studies play an important role in identifying appropriate motor-vehicle related improvements, but those strategies must be complementary with other roadway needs. The Albuquerque-Bernalillo County Comprehensive Plan establishes transportation policies and priorities that vary based on land development forms and the desired transportation infrastructure for the location. In particular, there are several types of Comp Plan-designated Centers and Corridors where accommodating transit, bicycle, and pedestrian travel must be considered alongside vehicle throughput. (See [Article 7-4 Roadway Design Context](#) of the DPM for additional information on Centers and Corridors). Considering the site context is important as not all locations should be treated equally and not all roads should serve the primary function of moving large volumes of cars long distances. Accordingly, acceptable levels of service (LOS), the typical measure of roadway performance in a TIS, may vary depending on the location, and the same standards cannot be applied equally in all situations.

## **Part. 7-6(B) Traffic Scoping Form and Traffic Impact Study**

### **Section. 7-6(B)(1) Traffic Scoping Form**

The first step in the evaluation of potential roadway impacts of a new development is a traffic scoping form. All development projects and sites that involve construction of greater than 5,000 SF of commercial space or generate traffic above basic thresholds require a traffic scoping form (See [Part. 7-6\(C\) Traffic Study Warranting Criteria](#)). The information provided in the TSF has two purposes:

1. To allow the Traffic Engineer to identify reasonable modifications that can be made to site plans that support the function of the transportation system and ensure safe and efficient access to and from the site to the adjacent roadway.
2. To determine if the site's impacts will meet the thresholds requiring a TIS. See [Part. 7-6\(C\) Traffic Study Warranting Criteria](#).

The traffic scoping form contains information regarding the proposed development, including description of the project uses and expected number of daily visitors. A TSF must be included alongside the site plan as part of an EPC, DRB or building permit application.

The applicant must submit an estimated number of daily trips generated by the site, as well as during the AM and PM Peak if known; assumptions will be made by the Traffic Engineer if such information is not provided. Depending on the location or magnitude of impacts a full TIS may be required; otherwise only a TSF is required. The traffic scoping form should be completed by the applicant and does not require the certification of a licensed engineer. The TSF shall be submitted before a building permit is issued.

City of Albuquerque staff will review the TSF and estimated trip generation levels to determine if further actions by the developer are required, including a TIS. Based on the findings of the traffic scoping form, the Traffic Engineer may require mitigation measures for roadway improvements or investments in transit, bicycle, or pedestrian infrastructure.

The City of Albuquerque Traffic Scoping Form can be found on the City of Albuquerque website at the following link: [Traffic Scoping Form](#)

### **Section. 7-6(B)(2) Traffic Impact Study**

Where weekday levels of traffic are expected to exceed certain thresholds, a TIS shall be required (see [TABLE 7.5.70](#) and [Part. 7-6\(C\) Traffic Study Warranting Criteria](#)). Unlike a traffic scoping form, where the requirements include a basic assessment of existing conditions, the expectations for a TIS are much greater. In particular, the TIS must consider the LOS for roadway segments affected by the proposed development. In addition to the impacts of the proposed development, potential mitigation measures on travel patterns in the project "influence area" should be evaluated. If the scale of the project is large enough, a traffic impact study may require analysis utilizing socioeconomic forecasts and should

consider travel demand model results from the most recent approved dataset from the Mid-Region Council of Governments (MRCOG).

A traffic impact study includes:

1. Review of existing conditions
2. Proposed site characteristics, including land uses and projected phasing of the development
3. Vehicle trips generated by the development site
4. Traffic analysis of affected intersections and roadways as a result of planned development
5. Site access requirements
6. Summary of findings
7. Mitigation measures

The TIS must be completed by a New Mexico licensed Professional Engineer, preferably with a PTOE certification and experience in preparing Traffic Impact Studies. A TIS shall be considered valid for three years from the date of approval by the Traffic Engineer.

An update to the trip generation analysis may be required if there is a change in the development or land use from the approved TIS.

Upon approval by the Traffic Engineer, an update to the trip generation analysis may also be utilized in lieu of a new TIS if more than three years have passed since the approval of the original TIS and no significant changes to the site or surrounding area have taken place.

See [Part. 7-6\(E\) TIS Report Elements](#) below for the full set of requirements for a TIS.

## **Part. 7-6(C) Traffic Study Warranting Criteria**

Warranting criteria are used to determine if a traffic scoping form or a TIS is required as part of the following development activities:

1. Rezoning  
Building permit for new building or change of use resulting in traffic above the levels in [TABLE 7.6.80](#)
2. Site plan
3. Subdivision
4. Area master plan

A TIS is generally required based upon the scale of the project and expected levels of traffic generation. [TABLE 7.6.80](#) indicates the conditions that warrant a TSF or TIS by location. In all instances where "TIS" is indicated in the table, a traffic scoping form must first be completed by the applicant and reviewed by the Traffic Engineer before a TIS should begin. The trip generation levels indicated in [TABLE 7.6.80](#) are based on site characteristics provided by the developer and reviewed by the Traffic Engineer. Volume-to-capacity (V/C) levels are calculated by the Mid-Region Council of Governments Congestion Management Process and based on current roadway conditions. This data is available

for all collector and arterials roadways in the City of Albuquerque through the *Transportation Analysis & Querying Application* (TAQA) tool.

Projects may be exempt from a TIS depending on their location or if the impacts are below certain thresholds. Regardless of the expected trip generation rates, large development projects are exempt from a TIS if the site is located Downtown, in a Comp Plan-designated Urban Center, or within 660' of a Premium Transit Station, as defined by the Comp Plan. The locations exempt from a TIS are marked by high degrees of non-auto travel, lower parking requirements, and are typically zoned for mixed-use development, which reduces trip generation levels.

**TABLE 7.6.80 Traffic Analysis Requirements by Location**

	10-100 AM or PM peak hour trips	10-100 AM or PM peak hour trips	Greater than 100 peak hour trips; Existing V/C < 0.5	Greater than 100 peak hour trips; Existing V/C > 0.5
<b>Center</b>	<b>Premium Transit Station</b>	TSF	TSF	TSF
	<b>Downtown</b>	TSF	TSF	TSF
	<b>Urban Center</b>	TSF	TSF	TSF
	<b>Activity Center</b>	TSF	TSF	TIS
	<b>Employment Center</b>	TSF	TSF	TIS
<b>Corridor</b>	<b>Major Transit</b>	TSF	TSF	TIS
	<b>Multi-Modal</b>	TSF	TSF	TIS
	<b>Commuter</b>	TSF	TIS	TIS
	<b>Other / No Designation</b>	TSF	TIS	TIS
	<b>Main Street</b>	TSF	TSF	TSF

**Section. 7-6(C)(1) Traffic Scoping Form Warranting Criteria**

A traffic scoping form is required for the following projects or sites:

1. Project/site generates 10 total trips during the AM or PM peak hour
2. Project/site contains more than 10 residential units
3. Projects/sites where uses have not yet been identified
4. Project/sites with a drive thru lane (e.g. fast food restaurant)
5. Project/sites with gas station and/or convenience center
6. Project/site contains a non-residential use of more than 5,000 ft<sup>2</sup>
7. Tenant improvement application generating additional 10 total trips during the AM or PM peak hour



A TSF may also be required or waived at the discretion of the Traffic Engineer. The Traffic Engineer will review the results of the traffic scoping form and make a determination if a TIS is required.

Generally, a traffic scoping form *only* – and not a TIS – is required under the following circumstances:

**NOTE:** A TIS is required along Commuter Corridors and “other” (i.e. non-designated) corridors regardless of current link-level congestion.

1. All projects that result in less than 100 AM or PM peak hour trips
2. All projects located Downtown, within a Comp Plan-designated Urban Center, or within 660’ of a Premium Transit station
3. Along Main Street Corridors
4. If a project generates more than 100 weekday AM or PM peak hour trips and is located along a roadway where the existing AM or PM peak hour volume-to-capacity (V/C) ratios are below an average of 0.5.

If the Traffic Engineer determines that a roadway abutting a project site is fully constructed and auto-oriented mitigation measures are impractical or unlikely to improve vehicle LOS, a traffic scoping form only may be required instead of a TIS. In these circumstances, the project may still be subject to non-auto oriented mitigation measures as determined by the Traffic Engineer, such as improved sidewalks, transit amenities, etc. See [Section. 7-6\(E\)\(8\)](#) for more information on potential mitigation measures.

### **Section. 7-6(C)(2) Traffic Impact Study Warranting Criteria**

A TIS may be required depending on the results of the traffic scoping form.

A TIS is warranted under the following conditions:

1. If a project generates more than 100 AM or PM peak hour trips per day and is located along Commuter corridors and non-designated or “other” corridors.
2. If a project results in more than 100 AM or PM peak hour trips per day and is located along designated Corridors or within designated Center and where the AM or PM peak hour volume-to-capacity ratios already exceed 0.5. Exceptions include Downtown, designated Urban Centers, Premium Transit station areas, and Main Street Corridors.

## **Part. 7-6(D) Traffic Analysis Procedures**

### **Section. 7-6(D)(1) Traffic Scoping Forms**

A traffic scoping form contains an initial analysis performed by the site developer and reviewed by the Traffic Engineer to consider general impacts associated with the site. The following items are required in a traffic scoping form:

1. Development information, including proposed land use and site activities
2. Facility type(s), including square footage and number of residential and/or commercial units
3. Traffic considerations, including estimated number of daily trips to the site (i.e. trip generation)

4. Presence and general condition of pedestrian and bicycle facilities within and across the study area
5. Preliminary site plan (include building size in square feet)
6. Other items as requested by the Traffic Engineer
7. The Traffic Engineer will review the traffic scoping form to determine if a full TIS is required. Additional considerations in the determination of whether a TSF is sufficient or if a TIS is required include:
8. Location in Comp Plan-designated Center or along designated Corridor
9. Daily traffic volume and peak hour link volume-to-capacity ratios (most current existing – available via the TAQA tool)
10. Presence of transit, bicycle, and pedestrian infrastructure

### **Section. 7-6(D)(2) Traffic Impact Studies**

#### **7-6(D)(2)(i) [Draft TIS Scoping Letter](#)**

If a TIS is deemed necessary, the site developer must prepare a draft TIS scoping letter that proposes the parameters for the TIS and identifies a study area. Potential parameters in the scoping letter may include:

1. Study area limits
2. Single or multi-phases of development
3. Site trip generation assumptions, including pass-by and internal capture trips
4. Adjacent developments
5. Other growth estimates
6. Build-out phases/horizon year
7. Capacity analysis/LOS analysis
8. Multi-modal considerations
9. Crash/safety considerations
10. Other planned or programmed roadway improvements
11. Other planned developments with background traffic
12. Neighborhood concerns
13. Applicable codes and public policies

#### **7-6(D)(2)(ii) [TIS Scoping Meeting](#)**

Traffic Engineer will review the TIS scoping letter and schedule a TIS scoping meeting with the site developer and affected agencies to confirm the parameters of the TIS. Data collection needs will be defined at this time. Vehicular and non-motorized traffic counts may be required for intersections within the study area, or as directed by the Traffic Engineer. All additional topics and the agreed upon TIS parameters shall be summarized in a final TIS scoping letter. This document shall be included in the appendix of the TIS.

#### **7-6(D)(2)(iii) [TIS Report Preparation and Review](#)**

The site developer will collect traffic data and prepare a TIS according to the agreed upon parameters. The developer will prepare the TIS with the elements as listed in 4.5 and begin identification of and traffic, transit or pedestrian mitigation measures. The City will review the TIS and provide comments as needed.

### 7-6(D)(2)(iv) [Mitigation Measures](#)

Mitigation measures should be proposed in the draft TIS as a way to moderate traffic generated by the development. Recommendations shall follow [Section 7-6\(E\)\(9\)](#) and consider a complete streets solution. The City and the developer will come to an agreement on the extent and nature of mitigation measures and those measures will be included in the final TIS.

#### **Steps in TIS Report Preparation and Review (in order):**

- a. Traffic Scoping Form (4.4.1) by developer
- b. Review of TSF by City Traffic Engineer (Follow steps c-j if a TIS is required)
- c. Draft TIS scoping letter submittal by developer
- d. City review of TIS scoping letter
- e. TIS Scoping meeting to confirm TIS parameters
- f. TIS report preparation and submittal by developer
- g. Review of draft TIS report by City staff. Staff comments provided.
- h. Identification and agreement of mitigation measures (additional meeting for negotiation may be required)
- i. Submit final report
- j. City approval of TIS

#### **TIS Report Elements**

1. Executive Summary
2. Introduction
3. Existing Conditions
4. Proposed Site Traffic Characteristics
5. Future Traffic Conditions and Analysis Years
6. Traffic Analysis
7. Site Access Requirements
8. Summary of Findings
9. Recommendations and Mitigation Measures
10. Appendix

## **Part. 7-6(E) TIS Report Elements**

The TIS shall include the following elements. Revision of requirements may be requested on a case by case basis at the TIS scoping meeting.

### **Section. 7-6(E)(1) Executive Summary**

The Executive Summary should include the following items:

1. Site location and study area
2. Development description and timeframe for completion
3. Summary of findings
4. Recommendations and mitigation measures

### **Section. 7-6(E)(2) Introduction**

#### **7-6(E)(2)(i) [Study Purpose](#)**

A general statement describing the intent of the report, and the reason it is being submitted (e.g., in support of a site plan, subdivision, etc.).

#### **7-6(E)(2)(ii) [Study Procedures](#)**

- a. *Information sources* - Applicant must provide documentation of their sources for trip generation and other factors related to expected travel demand within the influence area(s).

- b. Scope - The influence area encompasses the roadway elements that are assumed to be impacted by the proposed development. The influence area must be confirmed by the Traffic Engineer in the initial scoping meeting with the study preparer. The scope should consider the timeframe for site development.
- c. Level of Service (LOS) - The desired LOS for signalized intersections varies depending on the location, with lower levels of service and higher levels of congestion acceptable in Comp Plan-designated Centers and along certain Corridors as generally identified in Comp Plan Policies 6.1.4 through 6.1.9. This approach acknowledges that vehicle throughput and reduced auto delay is not the only objective in many situations. See [TABLE 7.6.81](#) for acceptable LOS by location and corridor type. [TABLE 7.6.82](#) provides acceptable LOS along Main Street Corridors.

Outside of designated Centers, the standard level of service for most arterials shall be LOS D where the roadway is controlled by traffic control devices (i.e., signalized or stop controlled intersections). For intersections, this applies to the average for each approach; however, the LOS for all approaches and movements must be reported in the TIS.

**TABLE 7.6.81 Table 4.5-1: Desired Level of Service by Location and Corridor Type**

Functional Classification & Roadway Type	Activity Center Type						
	Transit Station Area	Downtown	Urban Center	Activity Center	Village Center	Employment Center	Outside Activity Center
Premium Transit	E-F	E-F	E-F	E-F	E-F	E-F	E-F
Major Transit	E	E-F	E	E	D-E	D-E	D-E
Multi Modal	E	E	E	E	D-E	D-E	D-E
Commuter	E	E	D-E	D-E	D-E	D-E	D
Other Arterial	E	E	E	D-E	D-E	D-E	D
Minor Arterial	E	E	D-E	D-E	D-E	D	D
Collector	E	D-E	D	D	C-D	C-D	C-D

**TABLE 7.6.82 Table 4.5-2: Level of Service for Main Street Corridors**

Main Street	
Level of Service	E
Design Speed	25-30
Priority Travel Mode	Pedestrian

### Section. 7-6(E)(3) 4.5.3 Existing Conditions

The description of existing conditions should refer to data that is no more than three years-old. This information should include the following:

### 7-6(E)(3)(i) [General Area Characteristics](#)

1. Location within the City of Albuquerque (vicinity map)
2. General land use development adjacent to and at the site
3. Existing zoning at the site and for adjacent lands
4. Site plan including existing and proposed access locations
5. Other planned and approved developments, including description of the location and type of other planned and approved developments in the influence area (City will provide required information)

### 7-6(E)(3)(ii) [Area Street Network](#)

A detailed description of the street network in the influence area, including major roadways, and all information necessary for capacity analysis.

### 7-6(E)(3)(iii) [Existing Traffic Volumes](#)

The TIS may utilize data from the MRCOG Traffic Counts Program for link-level data for all arterials and collectors in the influence area (see the [TAQA tool](#)). An applicant should collect their own data if conditions have changed since the most recent count or if there is reason to believe the available counts are inaccurate.

For intersections where existing traffic counts and/or turning movement counts are not available, the applicant may be required to collect traffic counts data. The duration of the traffic counts and location of turning movement counts will be determined in consultation with the Traffic Engineer during the TIS scoping meeting. As the peak hours are the primary interest in the TIS, the turning movement counts can generally be limited to a 4-hour turning movement count, with two (2) hours in the AM peak period and two (2) hours in the PM peak period. Longer count times may be required by the Traffic Engineer if the existing intersection is known or expected to warrant a traffic signal; additional traffic volume data may also be requested to evaluate the need for traffic signalization.

### 7-6(E)(3)(iv) [Existing Levels of Service](#)

A description of the existing LOS for the study intersections using the latest version of a traffic analysis software approved by the Traffic Engineer.

### 7-6(E)(3)(v) [Existing Transit Service](#)

A description of the existing services, including frequency and span of weekday service, regional destinations served by adjacent transit service, as well as transit service amenities and bus stops in the project influence area. All proposed transit services in the influence area should be described.

### **7-6(E)(3)(vi) [Bicycle and Pedestrian Considerations](#)**

A description of the type and quality of pedestrian and bicycle infrastructure, including pedestrian access to transit stops. Gaps in the bicycle and pedestrian network in the influence area must be identified. Bicycle and pedestrian counts are required for sites or projects located in high pedestrian or bicycle activity areas (See section 23-3.5), and may be requested by the Traffic Engineer as part of vehicle counts data collection efforts.

### **7-6(E)(3)(vii) [Safety Evaluation/Crash Data](#)**

An evaluation of crashes over the 3-5 most recent years for which data is available and other safety considerations may be required.

## **Section. 7-6(E)(4) Future Traffic Conditions and Analysis Years**

### **7-6(E)(4)(i) [Project Implementation Year](#)**

Traffic forecasts shall be developed for the year the development is expected to be completed. Phased analysis may be required depending on the size and scale of the project, or as directed by City staff. Large projects with regional impacts may require that additional phases of development be evaluated, including horizon year analysis. Traffic volumes must account for three conditions: Site traffic, Growth in through traffic, other planned development.

### **7-6(E)(4)(ii) [Site Traffic –](#)**

The sum total of traffic attributable to the site development in the implementation year. The site traffic, or build traffic, plus the background traffic represents the total traffic on the study area roadway system.

### **7-6(E)(4)(iii) [Growth in Through Traffic –](#)**

Through traffic can be estimated using growth factors based on the most recent ten years of historical volume data. The use of growth factors is most appropriate for development periods of five years or less.

Growth rates should be based on a 10-year historical growth derived from the MRCOG Traffic Flow Maps. The minimum annual growth rate to be used is 0.5%. Growth rates should be defined in the TIS scoping letter and reviewed with respect to reasonableness in comparison to roadway capacity limitations and the long-range traffic forecast from the MRCOG regional travel demand model. Growth rates may also consider recent developments and their impacts on traffic volume patterns in the study area.

### **7-6(E)(4)(iv) [Other Planned Development](#)**

Other off-site development which is to occur prior to the project implementation year must be accounted for, and the traffic associated with this development must be included in the analysis. Where previous impact studies have been produced, the City will provide relevant data to the applicant.

The sum of the existing traffic, growth in through traffic, and the traffic generated by off-site development in the study area represents the background traffic for the implementation year analysis.

#### **7-6(E)(4)(v) Consideration of Programmed Roadway Improvements**

Transportation system improvements in the influence area that are programmed or committed to occur during the forecast period should be included in the analysis. The study should cite all projects in the influence area included in the City's Capital Improvement Program and the region's Transportation Improvement Program (facilitated by MRCOG).

### **Section. 7-6(E)(5) Proposed Site Traffic Characteristics**

#### **7-6(E)(5)(i) Site Development Characteristics**

The development characteristics must include the following:

1. An estimate of implementation phasing of the proposed development, to include the location and estimated year of occupancy of each phase
2. The specific type of land use to be implemented in each project phase; for example, gas station, hotel, residential dwelling units, etc., and the size and of type of proposed development (e.g., square feet of commercial space, number of dwelling units, etc.). The land use type and intensity should be expressed in the same terms as indicated in the ITE Trip Generation Manual for a given land use type.
3. Proposed access locations for each project phase, indicated on a drawing of the roadway network and showing intersections of interest, as defined in the scoping letter, and proximity to existing or proposed signalized intersections on the adjacent roadway system.

#### **7-6(E)(5)(ii) Trip Generation**

Provide a table showing the trips generated for the proposed development, and other planned developments in the influence area. Data for other planned developments may be provided by the City, including previous impact studies, as appropriate. The source of trip generation rates shall be from the current edition of *ITE Trip Generation Manual* or other resources sponsored by the **ITE Transportation Planning Council**. Assumptions regarding the types of trips (e.g. pass-by, diverted link, primary, etc.) must be clearly stated, and discussed with City staff at the scoping meeting. The influence area varies depending on the size of the development.

Other trip generation rates that represent local or site-specific conditions (e.g. mixed-use trip generation rates) may be used as prescribed by the Traffic Engineer, or as suggested by the study preparer and agreed to by the Traffic Engineer. In the latter case, however, the burden of justifying the validity and use of trip rates other than those in the ITE manual is on the study preparer.

### **7-6(E)(5)(iii) Other Trip Generation Considerations**

1. Pass-by Traffic and Internal Capture

In the TIS scoping letter, the applicant will identify the amount of any pass-by or internal capture trips that will be used in the traffic analysis.

- a. *Pass-by refers to the existing trips along a route that may visit the site*
- b. *Internal capture is the result of mixed-use activity in which one trip to the site results in visits to multiple businesses, or if there are trips to the new development that are generated within the site, such as in a development with a residential component. See ITE Trip Generation Manual for additional guidance.*

These assumptions shall be reviewed by the City, with Traffic Engineer approval documented in the response to the scoping letter or other formal written communication.

2. Transit

For sites in designated Centers or along Premium Transit and Major Transit Corridors, a percentage of trips to the site may be assumed to be completed via transit. This rate should be consistent with transit mode share data for the region or the corridor, if available, or based on a national study or reference manual.

### **7-6(E)(5)(iv) Trip Distribution**

Trip distribution shall be the percentage of traffic travelling a specific route to or from the site that passes through the intersections of study determined in the TIA scoping letter. The trip distribution informs the traffic assignment discussed below. This distribution is to be determined using the most recently-approved socioeconomic forecast from the MRCOG and will be based upon appropriate radii or distribution areas around the site, depending on the type of development. Land uses that serve regional markets should consider potential trips generated from a larger radius. The study area(s) and trip distribution methodology must be approved by the Traffic Engineer at the scoping meeting.

### **7-6(E)(5)(v) Traffic Assignment**

The number of trips entering and exiting the study site. These assignments will generally be required for both the morning and evening peak hour conditions. Assignment to specific movements and intersections will use logical routing onto the major street system and intersections of study. All trips shall be assigned to the access points, and all primary trips shall be assigned to the off-site intersections that will be evaluated within the study area. Pass-by trips should only be assigned to the site access points and internal capture trips should not be assigned to an access.

## **Section. 7-6(E)(6) Traffic Analysis**

### **7-6(E)(6)(i) Intersection and Roadway Analyses**

1. Identify intersections and roadways to be studied (includes all site access points).



2. Identify existing signal timing patterns for signalized intersections (to be provided by the Traffic Engineer).
3. Calculate intersection LOS and link-level volume-to-capacity ratios for the AM and PM peak periods under the following conditions:
  - a. Existing traffic (link-level data available through the MRCOG TAQA tool)
  - b. Project implementation year (includes other planned developments)
    - i. Baseline scenario, without proposed development (background traffic only)
    - ii. Build scenario, with proposed development (background plus site traffic)
4. The analysis of existing, or other warranted, signalized intersections shall be based on the operational/design procedures in the Highway Capacity Manual (HCM) or equivalent document as approved by the Traffic Engineer for the project implementation year.
5. Analysis of unsignalized locations, including major access driveways shall be based on the methodology contained in the HCM, or an alternative approach approved by the Traffic Engineer.
6. Assumptions regarding vehicle queuing, peak hour factors, heavy vehicle percentages, arrival types, right-turns-on-red, etc. may be included in the TIS report as needed.

#### **7-6(E)(6)(ii) Identify Alternative Intersection and Roadway Designs**

Alternative configurations shall be proposed for each intersection and roadway which fails to maintain the standard levels of service in the implementation year when considering either of the following conditions:

1. Background traffic only
2. Background plus site traffic

General description of roadway and intersection improvements are required for the implementation year, as deemed appropriate by the Traffic Engineer. The Traffic Engineer may waive this requirement if additional capacity is not feasible.

#### **7-6(E)(6)(iii) Evaluate Alternative Intersection and Roadway Designs**

The link-level capacity and intersection LOS of each of the alternative intersection and roadway designs shall be determined using the operational/design procedures of the most current HCM for the implementation year. Intersection analysis may be performed for the horizon year using the planning or operational methods of the most current HCM, or as deemed appropriate by the Traffic Engineer.

#### **7-6(E)(6)(iv) Perform Signalization and Stop Sign Warrant Analyses**

All locations meeting signal and stop sign warrants based on traffic volume in the implementation year should be identified. If an intersection is found to meet signal warrants based on the criteria contained in the Manual on Uniform Traffic Control Devices (MUTCD) in the project implementation year, a signal-

ized intersection operational analysis shall be performed using the procedures contained in the HCM. Recommendations for signal installation should be made as signal warrants are met. Upon review of the recommendations contained in the TIS, the Traffic Engineer will make a determination of whether the signal should be installed and/or provisions made for future signal installation. This determination shall be included in the final copy of the TIS.

### **Section. 7-6(E)(7) Site Access Requirements**

A description of the improvements needed to meet design and operational standards both on and off site. Required contents include the following:

1. Site Access and Circulation Plan
2. Roadway improvements
  - a. On-site
  - b. Off-site
  - c. Implementation phasing
3. Transportation System Management actions
4. Site design features such as turning lanes, median cuts, queuing requirements and site circulation, including driveway signalization and visibility.

### **Section. 7-6(E)(8) Summary of Findings**

A summary of the major implications of the proposed site development, including potential changes in LOS and other transportation conditions. Other considerations in this section may include discussion of illumination, traffic control alternatives, and observed deficiencies that are not identified through the analyses.

### **Section. 7-6(E)(9) Recommendations and Mitigation Measures**

Actions required to ensure that the roadway(s) affected by the project meet design and operations standards and to provide appropriate accommodations for bicyclists and pedestrians in the project area. Recommendations and mitigation measures should respond to the summary findings from the TIS.

Mitigation measures may be related to roadway improvements, including intersection improvements or changes to the roadway configuration, as well as infrastructure for alternative travel modes (i.e. transit, bicycle, or pedestrian improvements). Appropriate mitigation measures depend on the location and the desired infrastructure improvements in the project location. See the [Comp Plan Urban Design chapter \(7.A.6.2\)](#) and [Article 7-4 Roadway Design Context](#) of the DPM for additional information.

Multi-modal level of service analysis should be used as a diagnostic tool when identifying alternative mode mitigation measures and for evaluating the potential impacts of roadway-oriented mitigation measures in high bicycle and/or pedestrian activity areas.

#### **7-6(E)(9)(i) [Roadway Mitigation Measures](#)**

Mitigation measures may be requested following the completion of the traffic scoping form and a TIS, and must be proposed as part of a TIS if the impacts

of project cause the roadway LOS to exceed the standards prescribed for the project location.

The Traffic Engineer may determine that auto-oriented mitigation measures are not required because the roadway is fully constructed, no additional right-of-way is available, or if no measures are practical because the LOS cannot be substantially improved. In such cases alternative mode mitigation measures may be required.

Roadway mitigation measures may include, but are not limited to, the following:

1. Access management – closure of access points as part of a new development on a fully built-out street
2. Geometric improvements – turn lanes and other auxiliary lanes
3. Street restriping – additional travel lanes within existing right-of-way or reallocation of lane widths
4. Street widening and other physical improvements – additional travel lanes or other capacity expansion techniques; these measures must be demonstrated to be physically feasible
5. Traffic signal operations improvements – upgraded signals, signalization of un-signalized intersection, signal optimization, etc.
6. Transit capacity improvements – contributions toward expanded transit service

### **7-6(E)(9)(ii) Alternative Mode Mitigation Measures**

The goal of non-motorized mitigation measures is to reduce the demand for trips by single-occupancy vehicles and to increase opportunities for travel by alternative modes.

Mitigation measures may be related to the desired infrastructure improvements for the corridor type. Improvements to sidewalks and the pedestrian realm, transit amenities, and bicycle infrastructure may be requested as a mitigation measure in lieu of a roadway improvement.

Alternative mode mitigation measures are most appropriate along the corridor fronting the site or at adjacent intersections in Comp Plan-designated Centers, Premium Transit station areas, and along Major Transit, Multi-modal, and Main Street corridors.

Multi-modal accommodations are required in all circumstances for the frontage to the site and public right-of-way within the development. These accommodations may include:

- *Bicycle infrastructure – bike lanes, bicycle buffers, bike paint*
- *Connect sidewalk to curb for transit landing area*
- *Mid-block pedestrian crossings / HAWK signals*
- *On-site bicycle racks*
- *On-street parking*
- *Pedestrian connection from site to transit stop*
- *Restriping plan with narrower traffic lanes*
- *Street trees/landscape buffers*
- *Transit station amenities (e.g., but stop bench or shelter)*
- *Widen sidewalks/bring sidewalks into PROWAG/ADA compliance*

Transportation demand management strategies may be proposed to offset or reduce trip generation through carpool or ridesharing programs, contributions to transit service, on-site facilities for bicyclists, among other options.

### **Section. 7-6(E)(10) Appendix**

1. Maps and Supporting Graphics
2. Support Data for Analyses
3. Capacity Analysis Worksheets
4. Traffic scoping form
5. TIS scoping letter

## **Part. 7-6(F) NIA- Neighborhood Impact Assessment**

The Curb cut ordinance requires the preparation of a Neighborhood Impact Assessment (NIA), for all public, private or charter schools requesting access to City of Albuquerque streets.

- *Charter school* – A public school established under the authority of §§ 22-8B-1 to 22-8B-17.1 NMSA 1978.
- *Private school* – A school established, conducted and primarily supported by a non-governmental entity in which instruction is offered by one or more teachers and is discernible as a building or group of buildings generally recognized as an elementary, middle, junior high or high school or any combination of those.
- *Public school* – As defined at § 22-1-2 NMSA 1978 a part of a public school district that is a single attendance center in which instruction is offered by one or more teachers and is discernible as a building or group of buildings generally recognized as either an elementary, middle, junior high or high school or any combination of those and includes a charter school.

### **Section. 7-6(F)(1) NIA Purpose/Scope**

A NIA is a process to evaluate the overall effects that may result from the approval of curb-cut applications to allow access to public rights-of-way from public, private or charter schools, and to identify methods to mitigate such impacts to a reasonable level.

1. The permit applicant shall schedule an NIA scoping meeting for the NIA following the procedures as listed in [Section. 7-6\(D\)\(2\)](#)
2. The traffic engineer will determine at the NIA scoping meeting whether a Site Traffic Assessment (STA) or a Traffic Impact Study (TIS) is required.
3. Site Traffic Assessment (STA) – Analysis of site access (driveways), the need for turn lanes in advance of the site and impacts on signals downstream and upstream of the site. A STA is a lower level of analysis than a Traffic Impact Study.

### **Section. 7-6(F)(2) NIA Minimum Requirements**

1. A description of the project;
2. The baseline community data that identifies existing conditions with respect to adjacent land uses, traffic patterns, traffic turning movements and volumes, nearby multimodal transportation options, area pedestrian

- movements, and any other relevant information as determined at the time of scoping;
3. An analysis of the neighborhood impacts, if any, including but not limited to:
    - a. *impacts on pedestrian and bicycle circulation, and pedestrian and bicycle routes;*
    - b. *potential automobile and pedestrian conflict points;*
    - c. *potential noise and air quality impacts resulting from stacking of idling vehicles or vehicle circulation;*
    - d. *consistency with existing or planned transit routes and stops;*
    - e. *other potential impacts as determined by the Planning Director, City Engineer or designees;*
  4. If required a Traffic Impact Study (TIS) as described in section 23-4.5.
  5. A Site Traffic Assessment (STA), shall be conducted by a Professional Engineer licensed in the State of New Mexico with Traffic Engineering experience. The STA shall include an appendix with support data for analysis and capacity analysis and shall be signed and sealed in compliance with city standards by the engineer that prepared the report. At minimum and as more fully defined at the time of NIA scoping, it shall address:
    - a. *The impact that motorists arriving and departing from the school site will generate on traffic operations in the general vicinity;*
    - b. *The site's total capacity for student enrollment;*
    - c. *Anticipated student enrollment;*
    - d. *Scope of required analysis;*
    - e. *Need for a student drop off and pick-up queuing lane; and*
  6. An evaluation of reasonable alternatives, if any, and their anticipated effectiveness in mitigating potential impacts. The NIA shall include a justification by the applicant for the selection of a particular alternative or why no other reasonable alternatives existed.

## **ARTICLE 7-7** DEFINITIONS

A

Access Local Street	Access Local streets are loop streets, cul-de-sacs, and short segments that provide connections to other streets. Access Locals are not continuous for more than 1 or 2 blocks. Anticipated average daily traffic (ADT) for an Access Local street are 250 vehicles per day or less.
Activity Center	Activity Centers provide convenient, day-to-day services at a neighborhood scale to serve the surrounding area within a 20-minute walk or a short bike ride.
ADA Accessible Parking	An area on street or in a private property delineating a vehicular parking spot that is accessible to all, including those with physical disabilities.
Angled Parking	An area on street or in a private property delineating a vehicular parking spot at an angle from the curb or access aisle.

Arterial/Col-	The distance between major roads along a corridor.
Average Daily Traffic (ADT)	The average 24 hour volume of vehicles, being the total volume during a stated period divided by the number of days in that period. Normally, this would be periodic daily traffic volumes over several days, adjusted for days of the week or seasons of the year.
B	
Basic Transit Stop	Consists of an accessible boarding and alighting area with easily identifiable signage indicating the location of the stop.
Bicycle Boulevard	Enhanced bicycle routes designed to encourage the through-movement of bicycles while maintaining local access for motor vehicle travel.
Bicycle Buffer	The physical space that separates bicyclists from motorists.
Bicycle Facilities	Facilities including on-street bicycle lanes, separated multi-use paths, and buffers that provide additional comfort and safety for cyclists
Bicycle Lane	A lane on the roadway that has been designated by striping and pavement markings for preferential and exclusive use by bicyclists.
Bicycle Parking	An area on street or in a private property delineating a bicycle parking spot with a bicycle rack.
Bicycle Route	Designated roadways in which cyclists share roadway space with motorists.
Block length	The length of roadway between two intersections.
Bus Bays	A dedicated zone on the side of a roadway for passenger boarding and alighting that prevents travel lanes from being blocked when buses stop to pick up and drop off passengers. Bus bays have a protected zone with entrance and exit tapers.
Bus Turnouts	A dedicated zone on the side of a roadway for passenger boarding and alighting that prevents travel lanes from being blocked when buses stop to pick up and drop off passengers.
C	
Channelized Right Turn Lanes	An intersection type that provides for free-flow or nearly free-flow right turn movements usually with the use of curb islands.

Charter	A public school established under the authority of §§ 22-8B-
Community Principal Arterial	An arterial street designed to ensure that a particular mode is not to be prioritized at the expense of others, and that the corridor is meant to bring people to an area as opposed to through the area (as is the case with regional principal arterials).
Commuter Corridor	A higher-speed and higher-traffic volume route for people traveling across town, usually via limited-access roadways.
Comp Plan Corridors	A network of roadways that collectively meet the travel needs of Albuquerque and Bernalillo County residents
Comp Plan Centers	Areas of relatively intense development characterized by a variety of uses that allow for many different activities.
Complete Streets	Roadway(s) with Cross-Sections built at a human scale, designed and operated for equal access by all users, including pedestrians, bicyclists, motorists and transit riders of all ages and abilities, to allow comfortable and convenient street crossings, and pedestrian access to adjacent land uses.
Controlled Pedestrian Crossing	A location where vehicles are managed with traffic control devices which may facilitate pedestrian crossing.
Corral	A pen or enclosure for use in bicycle or motorcycle parking.
Cross Slope	The slope measured perpendicular to the direction of travel.
Cul-De-Sac	Short streets intersecting another street at one end and terminating at the other end with a vehicular turnaround.
Curb and Gutter	The area along the edge of a street that separates the elements in the Pedestrian Realm from the Travel Way and serves an important role in stormwater management.
Curb extensions	A traffic calming measure, primarily used to extend the sidewalk, and to reduce the crossing distance for pedestrians.
Curb Radius	The curvature along the curb line.
Curb Ramp	Provides access between elevated pedestrian facilities and road surfaces at pedestrian crossings.
Curb Ramp Counter Slope	The change in grade at the bottom of the curb ramp and adjoining road surface.
Curb Return	The curved section of curb connecting a street to an intersecting street or driveway.

Dedicated Transit Infrastructure	The portion of the road or right-of-way allocated exclusively for transit vehicles and associated improvements.
Design Speed	The speed motorists are intended to travel under free-flow traffic conditions.
Design Vehicle	The least maneuverable vehicle that routinely uses a street or a facility.
Designated Pedestrian Crossing	The location where pedestrians are encouraged to cross a roadway, as indicated by a combination of signal devices, signage, or pavement markings.
Detectable Warning Surface (DWS)	also Truncated Domes, Distinctive surface pattern of domes detectable by cane or underfoot that alert people with vision impairments of their approach to street crossings and hazardous drop-offs such as elevated transit loading area.
Diagonal Curb Ramps	A curb ramp located at the corner of an intersection which directs the user to the center of the intersection.
Directional Curb Ramps	A curb ramp with a running slope that is in-line with the direction of sidewalk travel.
Downtown	Albuquerque's Downtown serves as a regional hub for concentrated job and commercial activity supported by high-density housing and includes a wide variety of land uses.
Drivepad	The portion of a driveway in the right of way that connects a street to a commercial or residential driveway.
Driveway	An area on private property where vehicles and bikes are operated or allowed to stand.
E	
Effective Curb Radius	The curvature vehicles follow when turning at an intersection.
Employment Center	Employment Centers are intended to remain predominately industrial, business, and retail centers.
F	
Frontage Zone	The segment between the sidewalk and the property line, which may be located within the public right-of-way.



Hammer Head Streets	Short streets intersecting another street at one end and terminating at the other end with a vehicular turnaround.
High Bicycle Activity Areas	Facilities approaching and within a Comp Plan designated Centers, premium transit station areas, and schools. Other high activity areas include neighborhoods with an average residential density of 10 units per acre or more.
High Pedestrian Activity Areas	Comp Plan-designated Centers, Main Street Corridors, and Premium Transit station areas, as well as areas surrounding big box stores or clusters of retail activity, school zones, locations where buildings with zero setback are present, and neighborhoods with an average density of 10 units per acre. Multi-modal and Major Transit Corridors may also be considered high pedestrian activity areas depending on the surrounding land uses.
High Volume Traffic Generators	A site with over 25 vehicles entering or exiting per hour.
I	
Intersection	The location where two roadways (public or private) intersect.
Intersection Crosswalk	The pedestrian path across an intersection, whether it is marked or not.
Intersection Sight Distance	The distance required for drivers to be able to see a control device well in advance of performing a required action.
K	
Keyway	An area at the end of dead-end parking aisles for the maneuverability of vehicles.
L	
Landscape/ Buffer Zone	An area between the curb and the sidewalk that provides space for signage, utilities, storm water catchment, landscaping, street furnishings, and driveway aprons.
Level of Service (LOS)	A qualitative measure used to relate the quality of motor vehicle traffic service. LOS is used to analyze roadways and intersections by categorizing traffic flow and assigning quality levels of traffic based on performance measure like vehicle delay, speed, density, congestion, etc.

Long Range Bikeway Sys-	The regional network consisting of all existing and proposed bikeway and trail facilities.
Long Range Roadway System (LRRS)	The regional network consisting of all existing and proposed arterial and collector roadways.
Low Density Residential	Single family, mobile home, duplex, and town home developments.
M	
Main Street	Main Street Corridors are intended to be lively, highly walkable streets lined with local-serving businesses.
Major Local Street	Conveys traffic from other local streets to collector or arterial streets. The intent of Major Local streets is that sufficient space is available for two vehicles to travel unimpeded in opposite directions at the same time. Streets with an anticipated ADT of 1000 vehicles per day or greater are classified as Major Local streets.
Major Roads	Roads classified as arterials or collectors.
Major Transit	Major Transit Corridors are anticipated to be served by high frequency and local transit (e.g. Rapid Ride, local, and commuter buses).
Medians	The center portion of the roadway that separates general purpose travel lanes moving in opposite directions.
Mid-block Crossing	A form of designated pedestrian crossing that is not located at an intersection.
Mini Clear Sight Triangle	A triangular area at all drivepads that should be clear of visual obstruction.
Mitigation Measures	Infrastructure that helps to moderate the effect of traffic generated by a development.
Motorcycle Parking	An area on street or in a private property with a sign delineating a motorcycle parking spot.
Multi-Modal	Multi-modal corridors are intended to encourage the redevelopment of aging, auto-oriented commercial strip development to a more mixed-use, pedestrian-oriented environment that focuses heavily on providing safe, multi-modal transportation options.

Neighborhood Roadway Network	The local streets, often in a residential area, that are surrounded by the regional roadway network.
Neighborhood Traffic Circles	Small raised islands placed in intersections around which traffic circulates.
Normal Local Streets	Streets that direct traffic to Major Local streets or may connect directly to collectors and arterials. Streets with anticipated ADT from 250 to 1000 vehicles per day are classified as Normal Local streets.
O	
On-street Parking	Dedicated areas generally on the edge of the Travel Way and adjacent to the curb for vehicles to park.
P	
Parallel Curb Ramps	Curb ramp with running slopes that are in-line with the direction of sidewalk travel.
Parallel Parking	A vehicular parking area parallel to the road, in line with other parked vehicles
Park and Ride Facilities	Parking lots or formal station facilities that allow commuters and other transit users to leave their vehicles and transfer to public transit vehicles
Parking Islands	The ends of parking aisles that define parking stalls and provide adequate radii for vehicle turns and visibility.
Parklet	Also parquitos, Small public areas or commercial spaces supporting an adjacent business in which a curbside parking space is replaced with a seating area or gathering space that encourages additional activity along a street.
Paved Trails	also multi-use trails or shared-use trails, Are facilities that are dedicated for pedestrians and cyclists and are designed for use by people of all abilities for transportation and recreational purposes.
Pedestrian Access Route	An accessible corridor for pedestrian use within the pedestrian realm of the public right-of-way. The PAR is the path that provides continuous connection from the public right-of-way to building or property entry points, parking areas, public transportation, and/or other destinations. This route should be firm, stable, and slip-resistant and should comply with maximum cross slope requirements. The PAR should be at least four feet wide.

Pedestrian An area which includes the landscaping area and pedestrian

Permeable Pavement A paving material that allows for infiltration of fluids.

Perpendicular Curb Ramps A curb ramp that has a running slope that cuts through or is built up to the gutter grade break at right angles.

Premium Transit Premium Transit Corridors are intended to feature high-quality, high-capacity, high-frequency public transit (e.g. bus rapid transit).

Private school A school established, conducted and primarily supported by a non-governmental entity in which instruction is offered by one or more teachers and is discernible as a building or group of buildings generally recognized as an elementary, middle, junior high or high school or any combination of those

Private Street A street that is privately owned providing access to eight (8) or more dwelling units.

Private Ways A street that is privately owned providing access to small subdivisions with eight (8) or less dwelling units.

Public School As defined at § 22-1-2 NMSA 1978 a part of a public school district that is a single attendance center in which instruction is offered by one or more teachers and is discernible as a building or group of buildings generally recognized as either an elementary, middle, junior high or high school or any combination of those and includes a charter school.

## Q

Queue Jump Facilities Short transit-only facilities at intersections that are combined with signal prioritization to allow for buses to enter traffic flow ahead of general purpose travel lanes.

Queuing A line of vehicles waiting as in a drive through facility.

## R

Refuge Islands Median refuges or pedestrian safety islands (referred hereafter as “refuge islands”) are protected spaces in the center of the roads, and may be located at signalized or unsignalized intersections or at mid-block crossings.

Regional Principal Arterial Facilities where higher speed vehicle travel should be preserved and where access management strategies could be pursued.

Regional Roadway Net-	The system of collector and arterial roadways (also referred to as major roads) that provide mobility and access across
Reverse Angle Parking	also back-in angle parking, A parking configuration intended to improve the safety of on-street parking on bicycle routes.
Right-of-way	That area of land deeded, reserved or dedicated by plat or otherwise acquired by any unit of government for the purposes of movement of vehicles, bicycles, pedestrian traffic, and/or for conveyance of public utility services and drainage.
Road Diet	A range of techniques to encourage slower travel speeds and create space for pedestrian, bicycle, and transit users.
Roadway Re-construction	Projects that include the construction of new curbs or the horizontal relocation of the curb line.
Roundabouts	A form of intersection control in which motorists (and cyclists) travel counter-clockwise around a center island and yield at entry points to traffic.
Running Slope	The slope measured parallel to the direction of travel.
S	
Separated Bicycle Lanes	also protected bicycle lanes or cycle tracks, Include some form of vertical element to separate the bicycle lane from automobile travel lanes.
Sharrow	A shared bicycle lane marking placed in the travel lane to indicate where vehicles and bicycles share a travel lane.
Shoulder	The space between the outside of the driving lane and the curb or roadway edge, and generally serve as a buffer, to provide space for disabled vehicles on high-speed roadways, and to provide space for maintenance and emergency vehicles
Sidewalks	A hard-surfaced walk or raised path and any curb ramps or blended transitions along and generally paralleling the side of the streets for pedestrians.
Signalized Intersection	Intersection locations where vehicles are managed through a traffic signal.
Signalized Pedestrian Crossing	A designated pedestrian crossing in which traffic is forced to stop and the pedestrian is protected via a traffic signal or pedestrian-activated signal device.

Slip Ramp	A curb ramp used to connect an on-street bike facility to an
Stopping Sight Distance	The length of roadway visible to the driver and sufficiently long enough to enable a vehicle traveling at or near the design speed to stop or change lanes before reaching a stationary object in its path.
Stub Street	The extension of a street past an intersection where a turn-around is not required.
<u>Superelevation</u>	<u>Vertical design of roadways where the outside edge of pavement is higher than the inside edge.</u>
T	
Traffic calming Devices	also speed management techniques, used to control motor vehicle speeds and discourage through-vehicle trips.
Traffic Impact Study (TIS)	An in-depth examination of the potential traffic impacts of new development on nearby roadways.
Traffic Scoping Form (TSF)	An overview of roadway and transportation conditions at proposed development.
Transit Station	Usually associated with a premium service such as Bus Rapid Transit, transit stations are distinguished from transit stops by having level-boarding platforms and passenger amenities such as ticket vending machines and real-time transit information, as well as common transit stop amenities such as seating, shelters, and/or leaning rails.
Travel Lane	Dedicated area for vehicle traffic.
Travel Way	Area which includes the curb-to-curb area utilized for vehicle and bicycle travel.
Trip Generation Analysis	Analysis of the vehicular trips generated for a proposed development.
Turn Lane	A dedicated space for vehicles to complete a turning movement without blocking the flow of traffic.
Two-Way Left-Turn Lane (TWTL)	A continuous center lane that allows motorists traveling in both directions to pull out of through lanes and into a shared lane for left turns.

U

Uncontrolled Pedestrian	A location where pedestrians may cross a roadway where vehicles are not controlled.
Unsignalized Intersections	An at-grade intersection in which the flow of traffic is not controlled by a traffic signal. Unsignalized intersections may be STOP-sign controlled, YIELD sign-controlled, or uncontrolled.
Urban Center	Urban Centers are walkable districts that incorporate a mix of employment, service, and residential uses at a density and intensity lower than Downtown but higher than neighborhood-serving Activity Centers.
W	
Walkways	A passage or path for walking located on private property, which often connects the sidewalk to a building entrance or connects between different buildings on a site.

# CHAPTER 8

## SANITARY SEWER DESIGN CRITERIA

This chapter presents the criteria, standards and regulations related to the design of sanitary sewer systems for general development service. It does not cover the criteria necessary for design of major interceptor sewers, lift stations, or treatment facilities. The material is directed to the competent design professional and is not intended to be a detailed design handbook. Criteria and standards presented are those determined to be the minimum acceptable values necessary to result in system designs having satisfactory functional characteristics, durability and operational suitability. It is expected that the designer will strive for the best design to suit the circumstances involved, and that designs will reflect sound professional judgment at all times. Detailed requirements for various procedures to facilitate the sanitary sewer system are covered as follows:

### **ARTICLE 8-1** CONTENTS

<b>ARTICLE 8-1 GOVERNING REGULATIONS.....</b>	<b>488</b>
<b>ARTICLE 8-2 AVAILABILITY STATEMENTS .....</b>	<b>488</b>
<b>ARTICLE 8-3 DESIGN CAPACITY CRITERIA SECTION, DEVELOPMENT AND DEVELOPMENT SERVICE .....</b>	<b>489</b>
<b>ARTICLE 8-4 MANHOLE CRITERIA .....</b>	<b>490</b>
<b>ARTICLE 8-5 LINE CRITERIA .....</b>	<b>492</b>
<b>ARTICLE 8-6 CURVILINEAR SEWERS.....</b>	<b>494</b>
<b>ARTICLE 8-7 SERVICE CONNECTIONS CRITERIA .....</b>	<b>495</b>
Part. 8-7(A) Private collection systems and individual service connections	495



## ARTICLE 8-2 GOVERNING REGULATIONS

Ordinances and policies related to the design and operation of public water systems are listed in the [Public Water Systems Governing Regulations Summary](#), found on the City of Albuquerque website.

## ARTICLE 8-3 AVAILABILITY STATEMENTS

A [Water and Sanitary Sewer Availability Statement](#) issued by the Albuquerque Bernalillo County Water Utility Authority (Water Authority) /Utility Development Section within the past 12 months is required for any proposed development, subdivision plat, or site plan within or outside of the Service Area . Availability Statements will identify the water and sanitary sewer infrastructure needs (public/private; on/off site) to provide a proposed development with services and fire protection. In addition, any time constraints for development plans, or other requirements to receive services, will be identified in the Statement.

A request for an Availability Statement should be made as early as possible in the planning of a project to allow sufficient time for response and to enable the developer to include the necessary water and sanitary sewer infrastructure in the project plans. Requests for Availability Statements should include the following information:

1. The precise location of the proposed development, with a marked Zone Atlas map or legal description of the property.
2. The type of development proposed, such as single family residential, shopping center, office, etc., with a proposed schedule of development or phasing, if applicable.
3. The scope or size of the project and utility demands, if known (e.g. the number of units in a residential project, number of beds in a nursing facility, square footage for a shopping center or industrial development, etc.).
4. A copy of the Instantaneous Fire Flow Requirements from the Fire Marshal's Office. If a private sprinkler system is to be installed, state the flow requirements for that system, as well.
5. Any other information pertinent to project planning.

Requests for Availability Statements on Water and Sewer Service should be requested on the Water Authority's public website at: [www.abcwua.org](http://www.abcwua.org)

In cases of complicated or very large development proposals, additional study time may be required to prepare an Availability Statement. In such cases, the requester shall be notified of the extra time needed and advised of the status of the statement.

Where a proposed project is not sufficiently defined to provide all of the information required for an Availability Statement, the developer may request a [Serviceability Letter](#) in an effort to identify the water and sewer utilities nearest to the property and to ascertain the general feasibility of the project. However, in no case shall a Serviceability Letter replace the need for an Availability Statement.

No water or sanitary sewer service accounts shall be sold to any development project prior to issuance of a Water and Sanitary Sewer Availability Statement for that specific project. No property may develop or take service in such a manner that leaves adjacent un-served properties without means to obtain service. In accordance with the Water and Sewer Expansion Policies, line extensions are required to cover all frontage of the property requesting service

unless all adjacent properties have other means of being served. Unless modified for a specific project, specifications for pipe and other construction materials and specifications for construction will be as required in the current [City of Albuquerque Standard Specifications for Public Works Construction](#) and [Standard Details](#). Ordinances, policies and procedures related to the design and operation of sanitary sewer systems include the following:

## **ARTICLE 8-4 DESIGN CAPACITY CRITERIA SECTION, DEVELOPMENT AND DEVELOPMENT SERVICE**

1. Off-site flows will be typically determined by the Planning Department/Utility Development.
2. In areas with a mix of residential, commercial, industrial, etc., roughly representative of the city as a whole, the population of the contributing area is determined and the design flows are calculated as follows:
  - a. *Average Flow* =  $75 \times \text{Population} / 106$ , in MGD
  - b. *Peak Flow* =  $2.5 \times (\text{Avg.}) .8875$ , in MGD
  - c. *Design Flow* =  $1.2 \times \text{Peak}$ , in MGD
    - i Where  $cfs = \text{MGD} \times 1.547$
3. Population loadings are assumed to be:
  - a. *2.4 persons per DU for apartments, townhouses and mobile homes*
  - b. *2.4 persons per DU for R-1 single-family homes*
    - i Where  $DU = \text{Dwelling Unit}$
4. In primarily non-residential areas, design flows are determined by other methods as may be appropriate with the approval of the Water Authority. Contact the Water Authority for the latest values for water demand and sanitary sewer flows for various land used categories.
5. Design is for full pipe flow at the design flow.
6. Manning's Formula is to be used for determination of pipe flow velocities and capacities using a value for Manning's "n" = 0.013.
  - a. *Peak velocity = Velocity at peak flow conditions*
  - b. *Average velocity = Velocity at average flow conditions*

## ARTICLE 8-5 MANHOLE CRITERIA

1. Manholes must generally be located on the centerline of street right-of-way or of street width if the street is not concentric with the right-of-way. Manholes for straight lines in curved streets may be located as much as 5' off from centerline of street or right-of-way; however, required clearances from other utilities must be maintained. The offset of such manholes is to be dimensioned from center of manhole barrel to the centerline of the street or right-of-way. In narrow, curving, residential streets, greater than 5' offset may be appropriate to maintain separation from other utilities. Avoid locating manholes in the "wheel path" on arterial and collector roadways, and keep them out of "Parking" lanes and spaces. Manhole locations that conflict with centerline monumentation required for subdivisions, should be shifted, when practical, to eliminate the conflict. Manholes will not be allowed outside of public right-of-way within residential areas except in private streets or within multifamily housing with public easements. All manholes must be accessible by sewer maintenance truck. Manhole locations in residential rear or side yards are not acceptable.
2. Standard minimum manhole depth is 6.0', measured from rim to invert. Manhole depths greater than 20 feet shall be avoided.
3. The required inside diameter for a manhole is determined as follows:
  - a. Minimum inside diameter is 4.0'.
  - b. A minimum 9" wide shelf must be provided on each side of each main line within the manhole.
  - c. Where the main flow changes direction at a manhole, the manhole must be large enough so that the centerline radius of a curvature of the flow invert will be larger than the pipe diameter.

Minimum manhole diameters required for direction changes will be as follows:

Pipe ID	0°	5°	45°	50°	75°	80°	85°	90°
21"	4'	4'	4'	4'	4'	4'	4'	4'
24"	4'	4'	4'	4'	4'	4'	4'	6'
27"	4'	4'	4'	4'	4'	4'	6'	6'
30"	4'	4'	4'	4'	4'	6'	6'	6'
36"	6'	6'	6'	6'	-	-	-	-
42"	6'	6'	6'	-	-	-	-	-

4. Flow will not be permitted to change horizontal flow direction by more than 90 degrees in a manhole. Under the following conditions, the maximum horizontal change in flow direction permitted will be 50 degrees although special design considerations will be made where the situation warrants:
  - a. All lines larger than 36".
  - b. Any lines with a design flow greater than 3.0 MGD and a design velocity of 5.0 fps or greater.
  - c. Any junction of two flows, each with design flow greater than 3.0 MGD, where one line has a design pipe velocity of 5.0 fps or greater.

5. Invert elevations will be called out for each inlet and outlet at a manhole.
6. Drops across manholes will be provided as follows:
  - a. Where the main flow does not change direction at the manhole, the design will provide:
    - i A slope across the manhole at least equal to the average of the slopes of the incoming and outgoing lines.
    - ii The minimum drop will be 0.10' for lines 36" and smaller.
  - b. Where the main flow changes direction at the manhole, the design will maintain the average of the slopes of the incoming and outgoing lines and compensate for the loss of velocity head caused by the turn.
    - i The slope component will be equal to the average of the slopes of the incoming and outgoing lines times the diameter of the manhole.
    - ii

The velocity head component will be determined by the following formula:

$$\text{EQUATION 7.66 } h_b = K_b \frac{V^2}{2g}$$

where:

$h_b$  = required drop to compensate for loss of velocity head (ft).

$K_b$  = bend coefficient, use 0.4 for 90° turn, 0.32 for 45° turn and linear proportioning for other deflection angles (dimensionless).

$V$  = design velocity of incoming line based on design flow, ft/sec.

$g$  = 32.17 ft/sec<sup>2</sup>.

- iii The total drop required through the manhole will be the sum of the slope component and velocity head component.
    - iv The minimum drop through a manhole will be 0.10'.
  - c. Where flows converge at a manhole, the inverts should be designed to produce a smooth water surface at design flow with no backwater conditions in any of the incoming lines. Excessive drops which cause turbulence are to be avoided.
  - d. The use of drop connections to manholes (drop manholes) will be allowed when approved by the Water Authority and in conformance to Standard Details.
7. Drop manholes and other manholes with high potential of sulfide gas generation must be designed with corrosion resistant interior walls, when required by the Water Authority.
  8. The maximum distance allowed between manholes is:
    - a. 8" to 21" mains - 450' maximum
    - b. 24" & larger - 500' maximum for average velocities of 3.0 fps or less
  9. When an interim line extension is to be built for a distance less than the reasonable spacing for a manhole installation, the Utility Development representative to Development Review Committee (DRC) may allow installation of a plug. The design drawings for such installation must provide a design to the next anticipated, upstream manhole location, with line and manhole beyond the temporary clean out depicted as "Future."
  10. Manhole steps will not be allowed in new manhole construction.

## ARTICLE 8-6 LINE CRITERIA

1. Sanitary sewer materials must comply with the requirements set forth in the *City of Albuquerque Standard Specifications for Public Works Construction* and *the Standard Details*, latest edition.
2. Minimum line size allowed: 8" inside diameter.
3. The minimum slope considered necessary in non-curved lines shall provide a minimum design velocity of 2.2 ft/sec. Greater slopes than minimum are desirable and are to be provided where possible. Maximum slopes should never result in super critical flow.
4. Sections of line that are flat relative to the upstream line are to be avoided. As much as possible, continuous flow velocity and capacity will be provided. The energy gradient should slope generally parallel to the slope of the invert with no abrupt changes nor slopes opposite to the direction of flow.
5. Line depth should be sufficient to provide gravity service to property contiguous to the line. Additional depth may be required to provide for service. Generally, house services shall be a minimum of 4' below the top of curb at the property line as measured from the top of curb to the invert of the services.
6. Low pressure force mains shall not be allowed unless approved by the Water Authority. As determined by the Water Authority, variances may be given in some instances for minimum slopes and manhole depths to allow for a gravity system in lieu of a low pressure for main system.
7. The main lines are to be located within public right-of-way except as noted in *Article 8-5.7a* and are to be aligned in accordance with the *Primary Utility Locations, Figures 1-5*. Where the Primary Utility Locations do not apply, the following criteria apply:
  - a. *The New Mexico Environment Department policy on the proximity of water and sewer lines, with City amendments as follows:*
    - i *Sewer lines should be laid at least 10 feet horizontally from any existing or proposed water main. In situations where it is not feasible to maintain a 10 foot separation, the distance may be reduced on a case-by-case basis, if supported by information from the Design Engineer. The water main must be in a separate trench or on an undisturbed earth shelf located on one side of the sewer line and at an elevation such that the bottom of the water main is at least 18 inches above the top of the sewer line.*
    - ii *Sewer lines crossing water mains should be laid to provide a minimum vertical separation of 18 inches between the outside of the water main and the outside of the sewer line. This separation should be maintained where the water main is either above or below the sewer line. The crossing should be arranged so that the sewer line joints will be equidistant and as far as possible from the water main (~10 feet).*
    - iii *When it is impractical to obtain proper horizontal and vertical separation, the sewer line should be designed and constructed of pressure rated (125 psi), plastic pipe, and should be pressure tested similar to a water line to assure water tightness. When pressure rated pipe is required for a sewer crossing, it shall be installed the entire distance between the adjacent manholes.*
  - b. *Main lines must be located so that they can be maintained without disturbing any sidewalk, curb, gutter or any other utility. The required trench must be totally within the paved roadway or utility easement.*



## **ARTICLE 8-7 CURVILINEAR SEWERS**

Straight line sewers shall be utilized as much as possible. Straight line systems are often possible with no increase in the number of manholes by allowing the line to vary a maximum of 5' to the inside or outside of the centerline, depending on the location of the water line and of other utilities.

Curvilinear sewers are permitted, in accordance with the following criteria:

1. The pipe length to be used, deflection angle, joint length and offset, and radius of curvature must be stated on the plans.
2. Manholes must not be placed within 5' of the beginning and the end of street centerline curves, to allow for street centerline monumentation.
3. The minimum radius of curvature will be as follows:

<b>Pipe Type</b>	<b>Pipe Diameter</b>	<b>Joint Length (NOM)</b>	<b>Minimum Radius</b>
<b>DIP</b>	8" - 12"	18'	300'
<b>PVC</b>	8"	20'	275'
<b>PVC</b>	10"	20'	330'
<b>PVC</b>	12"	20'	400'
<b>VCP</b>	8" - 12"	4'	130'
<b>VCP</b>	8" - 12"	6'	200'

4. The maximum distance between manholes on a curvilinear sewer is 300'.
5. The slope of the curvilinear sewer must be at least 5% greater than the upstream straight line sewer. Additionally, the minimum slope criteria for curvilinear sewers is shown below:

<b>Sewer I.D.</b>	<b>Slope</b>
<b>8"</b>	0.0066
<b>10"</b>	0.0030
<b>12"</b>	0.0024
<b>15"</b>	0.0018

## ARTICLE 8-8 SERVICE CONNECTIONS CRITERIA

### Part. 8-8(A) Private collection systems and individual service connections

1. Service connections must be made to the main line except at the end of cul-de-sacs where connection to a manhole is permitted in the manner shown in the Standard Detail Drawings.
2. Service connections to a manhole are to be made with the invert of the service at the elevation of the top of the main line.
3. Service connections to mains will be constructed as follows:

Service Size	Main Size	Connection Method
4"	8"	Insert manufactured TEE/WYE
4"	8"	Core drill main and install saddle
6"	8"	Insert manufactured TEE/WYE
6"	8"	Install manhole
6"	10" and greater	Insert manufactured TEE/WYE
6"	10" and greater	Core drill main and install saddle
8"	8" and greater	Install manhole

4. Drop connections at manholes shall be constructed as shown on Standard Details.
5. Service connections shall not be made to lines with peak design flow capacity greater than 3.0 MGD or with diameter greater than or equal to 15 inches.
6. All service connections shall be made such that the service is perpendicular or radial to the sewer main.
7. All service connections shall have a minimum slope of 1/4" per foot toward the main within the public right-of-way and shall have a minimum depth of 4' below the top of curb elevation from the finished surface projected to the property line measured to the pipe invert.



# CHAPTER 9

## WATER SYSTEM DESIGN CRITERIA

This chapter presents the criteria, standards and regulations related to the design of water distribution systems for general development service. It does not cover the criteria necessary for design of major transmission lines, wells, pumping facilities, or reservoirs. The material is directed to the competent design professional and is not intended to be a detailed design handbook. Criteria and standards presented are those determined to be the minimum acceptable values necessary to result in system designs having satisfactory functional characteristics, durability and operational suitability. It is expected that the designer will strive for the best design to suit the circumstances involved, and that designs will reflect sound professional judgment always. Detailed requirements for various procedures to facilitate the public water system are covered as follows:

### **ARTICLE 9-1 CONTENTS**

<b>ARTICLE 9-1 GOVERNING REGULATIONS .....</b>	<b>497</b>
<b>ARTICLE 9-2 AVAILABILITY STATEMENTS .....</b>	<b>497</b>
<b>ARTICLE 9-3 WATER LINE DESIGN CRITERIA.....</b>	<b>497</b>
Part. 9-3(A) General Requirements.....	497
Part. 9-3(B) Single-Family and Duplex Developments.....	498
Part. 9-3(C) Industrial/Commercial and Multi-Family Developments .....	498
Part. 9-3(D) Material Requirements .....	498
Part. 9-3(E) Waterline Designations .....	498
Part. 9-3(F) Minimum Waterline Depths.....	499
Part. 9-3(G) Thrust Restraints.....	499
Part. 9-3(H) Water Valve Shut Off Plans.....	499
<b>ARTICLE 9-4 ALIGNMENT AND EASEMENTS .....</b>	<b>500</b>
<b>ARTICLE 9-5 VALVING .....</b>	<b>502</b>
<b>ARTICLE 9-6 SERVICE LINES AND METERS.....</b>	<b>503</b>
<b>ARTICLE 9-7 PRIVATE DISTRIBUTION SYSTEMS.....</b>	<b>504</b>
<b>ARTICLE 9-8 FIRE HYDRANT CRITERIA.....</b>	<b>504</b>
Part. 9-8(A) General Information.....	504
Part. 9-8(B) General Fire Hydrant Requirements for Fire Protection .....	505
Part. 9-8(C) New Buildings, Building Additions or Building Reconstruction	506
Part. 9-8(D) Existing Development and building Fire Hydrant Deficiencies	507

Part. 9-8(E) Public Fire Hydrant Installation Procedure ..... 507

**ARTICLE 9-9 FIRE FLOW REQUIREMENTS..... 508**

## **ARTICLE 9-2 GOVERNING REGULATIONS**

Ordinances and policies related to the design and operation of public water systems are listed in the [Public Water Systems Governing Regulations Summary](#), found on the City of Albuquerque website.

## **ARTICLE 9-3 AVAILABILITY STATEMENTS**

A [Water and Sanitary Sewer Availability Statement](#) (Availability Statement) issued by the Albuquerque Bernalillo County Water Utility Authority (Water Authority) /Utility Development Section within the past 12 months is required for any proposed development, subdivision plat, or site plan within or outside of the Service Area . Availability Statements will identify the water and sanitary sewer infrastructure needs (public/private; on/off site) to provide a proposed development with services and fire protection. In addition, any time constraints for development plans, or other requirements to receive services, will be identified in the Statement. A request for an Availability Statement should be made as early as possible in the planning of a project to allow sufficient time for response and to enable the developer to include the necessary water and sanitary sewer infrastructure in the project plans.

Detailed procedures and submittal requirements for requesting a water and sewer Serviceability Letter or Availability Statement are provided in [Section 8-4 of Chapter 8](#).

## **ARTICLE 9-4 WATER LINE DESIGN CRITERIA**

### **Part. 9-4(A) General Requirements**

1. The sizing and routing of Master Plan lines must be coordinated with and approved by the Water Authority/Utility Development Section. Specific requirements for providing water (and sewer) service to any parcel or development will be specifically defined in a "Water and Sewer Service Availability Statement" from the Water Authority . The procedure for obtaining an Availability Statement is outlined in [Chapter 2, Part. 2-3\(B\) Infrastructure Design Development Procedure](#).
2. Pressure zone boundaries must be considered in the design of all systems.

3. A distribution line must be provided for all streets except in local residential streets where no lots front the street.
4. Location of lines must be according to Primary Utility Locations, [Chapter 24, Figures 24.1 - 24.5](#). Deviations will require approval of the Water Authority.
5. All lines must be looped. No dead ends will be allowed, except those as approved by the Water Authority.
6. No property may develop or take service in such a manner that leaves adjacent outlying undeveloped or developed un-serviced properties without means to obtain service. Line extensions are required to cover all frontage of the property requesting service unless all adjacent properties have other means of being served.
7. Taps to concrete cylinder pipes are prohibited.
8. For new construction, 14-inch water line size is prohibited.

### **Part. 9-4(B) Single-Family and Duplex Developments**

Sizing requirements are as follows:

1. Typical 6" minimum.
2. A minimum 8" line is required where the system's 6" lines are not interconnected to an 8" at intervals of 1200' or less.
3. Minimum 6" line to any fire hydrant.
4. May allow 4" line into cul-de-sac with a maximum of eight (8) units if there are no fire hydrants on the line.
5. Fire protection may require larger sizing. Determination is made by the Water Authority. (See [Article 9-9](#) for additional information.)

### **Part. 9-4(C) Industrial/Commercial and Multi-Family Developments**

Sizing requirements are as follows:

1. Typical 8" minimum.
2. Fire protection may require larger sizing. Determination is made by the Water Authority. (see [Article 9-9](#))

### **Part. 9-4(D) Material Requirements**

Materials must be in accordance with the current [City of Albuquerque Standard Specifications](#) and [the Standard Details](#).

### **Part. 9-4(E) Waterline Designations**

Designations relate to the function intended for the lines, as described below:

1. Transmission lines are generally lines conveying water from pumping facilities to reservoirs or lines conveying water directly between pumping

- facilities or directly between reservoirs. Such lines generally may not be tapped for any purpose without specific Water Authority approval.
2. Master Plan lines are generally major network distribution lines. They are termed Master Plan because they are designated as specific elements of facilities Master Plans. These lines provide service to local distribution lines and generally may not be tapped for individual service without specific Water Authority approval.
  3. Distribution lines are generally lines providing local distribution of water and from which individual user service taps are made. Distribution lines stem from Master Plan lines or from other local distribution lines. Both Master Plan and distribution lines are sometimes referred to as “main lines” or “mains.”
  4. Service lines are lines providing service from the local distribution line directly to the individual user’s meter.
  5. Collector or Well Collector lines are lines that gather water directly from wells and convey to pumping or other facilities. These lines shall not be tapped for any purpose.

### **Part. 9-4(F) Minimum Waterline Depths**

Depth to the top of waterlines shall be as follows:

1. Transmission lines shall have 4’ minimum cover from top of grade to top of water line.
2. Distribution lines shall have 3’ minimum cover from top of grade to top of water line.
3. Channel and ditch crossing depths and details must be reviewed and approved by City Hydrology Division, Middle Rio Grande Conservancy District (MRGCD) and/or the Albuquerque Metropolitan Area Flood Control Authority (AMAFCA), depending upon jurisdiction for the affected waterway.

### **Part. 9-4(G) Thrust Restraints**

Thrust restraint design shall conform to the following:

1. Water line tees, bends, valves and fittings must be restrained against thrust forces to prevent movement or failure of the water line.
2. Thrust restraint shall be in accordance with the [\*City of Albuquerque Standard Specifications for Public Works Construction\*](#). The designer is responsible for providing, on the construction drawings, an adequate restraining system design for the water line, including minimum length of restrained pipe required in each direction.

### **Part. 9-4(H) Water Valve Shut Off Plans**

1. Construction plans that specify modifying or adding to, the public water system must include a water valve shut off plan, if a shut off is needed to complete the work. Prior to submittal of the proposed shut-off plan, the designer shall field verify the existence and accessibility of the valves involved in the plan and request a trial water shut-off by the Water Authority.
2. At a minimum, the shut off plan will include the following:

- a. Schematic showing valve numbers and locations, water line sizes and types, and streets in the shut off area.
- b. Valve numbers of all valves that must be closed to accomplish the shut off plan.
- c. The following notes:
  - i “ The request for a water shut-off or turn-on for a main designated as a Distribution Line must be submitted at least seven (7) working days before the date of the actual shut-off or turn-on.
  - ii The request for a water shut-off or turn-on for a main designated as a Transmission Line, Master Plan Line, Collector, or Well Collector Line must be submitted at least fourteen (14) working days before the date of the actual shut-off or turn-on.
  - iii The request for a water shut-off or turn-on for a San Juan Chama designated transmission line or any other water line in the vicinity of San Juan Chama lines will be required to follow the procedures stated in the Water Authority Administrative Instruction No. 9 and must be submitted at least thirty (30) working days before the date of the actual shut-off or turn-on.
  - iv The Contractor shall complete the appropriate Water Authority Electronic Shut-off Request form for all shut-off requests and submit all required design documentation. Only authorized personnel designated by the Water Authority are permitted to operate public water system valves.”
3. The shut off plan must be submitted as part of the construction plan set during the design review process.

## **ARTICLE 9-5 ALIGNMENT AND EASEMENTS**

1. The main lines are to be located within public right-of-way, except as noted below, and aligned in accordance with the Primary Utility Locations [Chapter 8, Section 8-5](#). Water lines must be located so that they can be maintained without disturbing any sidewalk, curb, gutter, structure, or any other utility. For lines within streets, the construction trench is required to be contained totally within the paved roadway.
2. If circumstances require location of water lines in other than the location established by the Primary Utility Locations, approval of both the Water Authority and the utilities normally expected to occupy the revised location must be obtained.
  - a. Main lines may be located outside public right-of-way only with prior approval of the Water Authority and only within appropriate easements.
3. If not in public right-of-way, the distribution line must be located as follows:
  - a. In a gravel or paved, permanent access easement, including an easement for the water line, or
  - b. In a planned, landscaped area with access suitable for maintenance equipment and within an appropriate easement. Trees shall not be planted within 10' of the centerline of the water line.
  - c. If a or b of this subsection above are impossible because of prior platting, the location will be handled as a special case.
  - d. In private streets, Primary Utility Locations apply where possible.
4. Easement Requirements and Restrictions:

- a. A permanent easement must be granted for the exclusive use of water and sanitary sewer, unless shared use with other utilities is coordinated and approved in advance by the Water Authority . A minimum width easement of 20' is required for a single utility and 25' for water and sewer both within the same easement. Appropriate forms of easement language may be obtained from the Water Authority.
  - b. A public water and/or sanitary sewer easement granted across private land cannot be split by a lot line. The easement must be contained entirely within a single lot.
  - c. The following structures and obstructions are prohibited within Water Authority water / sewer easements:
    - i Buildings
    - ii Walls and fences that run parallel to, and are contained within, the easement
    - iii Trees
    - iv Curb, gutter, and/or sidewalks that run parallel to, and are contained within, the easement
    - v Any other structure that would be damaged or destroyed if the utility lines needed to be exposed for maintenance or repair.
5. Where the Primary Utility Locations do not apply, lines shall be in accordance with the New Mexico Environment Department policy on the proximity of water and sewer lines with amendments as follows:
- a. Sewer lines should be laid at least 10 feet horizontally from any existing or proposed water main. In situations where it is not feasible to maintain a 10 foot separation, the distance may be reduced on a case-by-case basis, if supported by information by the Design Engineer. The water main must be in a separate trench or on an undisturbed earth shelf located on one side of the sewer line and at an elevation such that the bottom of the water main is at least 18 inches above the top of the sewer line.
  - b. Sewer lines crossing water mains should be laid to provide a minimum vertical separation of 18 inches between the outside of the water main and the outside of the sewer line. This separation should be maintained where the water main is either above or below the sewer line. The crossing should be arranged so that the sewer line joints will be equidistant and as far as possible from the water main (~10 feet).
  - c. When it is impractical to obtain proper horizontal and vertical separation, the sewer line should be designed and constructed of pressure rated (125 psi) pipe, and should be pressure tested like a water line to assure water tightness. When pressure rated pipe is required for a sewer crossing, it shall be installed the entire distance between the adjacent manholes.
  - d. If local constraints dictate that the water line must be installed near existing sanitary sewer facilities, use concrete/clean fill encasement in accordance with NMED requirements.
6. The minimum radius of water line curvature is:

**TABLE 9.5.88 Minimum Curvature Radius**

Pipe Type	Pipe Diameter	Joint Length (NOM)	Minimum Radius
DIP	4" - 12"	20'	300'
PVC	4"	20'	135'
PVC	6"	20'	190'

Pipe Type	Pipe Diameter	Joint Length (NOM)	Minimum Radius
PVC	8"	20'	250'
VCP	10"	20'	310'
VCP	12"	20'	370'

## ARTICLE 9-6 VALVING

The design of valving within the water system shall conform to the following criteria:

1. Valve Spacing
  - a. 2600' maximum between in-line valves for Master Plan lines 16" and larger.
  - b. 1200' maximum between in-line valves for lines 14" and smaller.
2. Branch Intersections
  - a. Near the intersection of a branch line connection to a Master Plan line, the branch line must be valved. Near the intersection of non-master plan main lines, all lines but one (1) must be valved.
3. Fire Hydrants
  - a. Fire hydrant legs must be valved.
4. System valving
  - a. The system valving must be arranged so that lines may be shut down with a minimum number of valves and affecting the minimum service area. Valving of the ultimate system looping must be such that no break will disrupt service beyond the next valve location. System valving design should assure that only the immediate area where the break occurs will suffer disruption of water supply and that only one (1) hydrant will be placed out of service.
5. Valve location:
  - a. Standard location for valves is at the PC/PT of the curb return.
  - b. Valves for pressure connections of branches to existing water lines at intersections will be dismantled/removed and buried.
  - c. Do not locate valves under parking spaces.
  - d. Do not locate valves within intersections.
6. Unmetered fire lines
  - a. Unmetered fire lines must be valved for Water Authority use within the public right-of-way and a separate private valve located on private property at the property line for use by the owner. Please refer to the [COA Standard Detail](#).
7. Valve Types
  - a. Valves 12" and smaller must be gate valves.
  - b. Valves 14" and larger must be butterfly valves.
8. Valve Sizing
  - a. All valves shall be the same size as the main lines.
9. Air Relief Valves
  - a. No air relief valves or air relief hydrants are required on lines 8" or smaller where there are services on the line.
  - b. On Master Plan lines and distribution lines greater than 8", sizing and location of air relief hydrants and valves must be coordinated with the Water Authority.

10. Pressure Reducing Valve (PRV) Stations
  - a. *The Water Authority determines the need for pressure reducing valve stations and their locations. The size of the PRV shall be coordinated with the Water Authority. Station design will generally be in conformance with the [Standard Details](#).*

## **ARTICLE 9-7 SERVICE LINES AND METERS**

The following criteria is provided for service lines/meters designs:

1. The metered service line is public through connection with the outlet of the meter or meter setter.
2. Sizing of the service line and meter is the responsibility of the requestor or his agent. The Water Authority will, upon request, provide information relative to the flow characteristics of the various available metered sizes. Every meter shall be supplied by its own service line. Any meters larger than 5/8" × 3/4" shall require supporting calculations.
3. The public portion of the service line including the meter and box may be installed by a New Mexico licensed and bonded contractor.
4. The design of the entire service line installation must follow the [Standard Details](#) for the desired size of meter and line combination. The water mains and service lines must be completed, including flushing and disinfection, and accepted formally in writing before the Water Authority will install meters. In addition, the entire subdivision included in the Construction Agreement must be formally accepted in writing by the Water Authority before the Water Authority will install a meter. Upon completion and acceptance of the project, the Water Authority will install the meter after formal application and payment of all appropriate charges.
5. Typically meters 2" and smaller are located within the public right-of-way, behind the street curb as shown in the [Standard Details](#).
6. Meters 3" and larger require a permanent easement on the landowner's property.
  - a. *The easement locations and sizes will be determined on an individual basis to suit the circumstances.*
  - b. *The easement must be outside areas occupied or possibly occupied in the future by underground or above ground utility systems or street fixtures.*
  - c. *The landowner must provide the Water Authority with three (3) copies of the recorded easement, legal description and certificate of survey before installation begins.*
7. Mains equal to and larger than 16" shall not to be tapped for service.
8. Meters for any installation may only be installed by the Water Authority after formal application and payment of all appropriate charges.



## ARTICLE 9-8 PRIVATE DISTRIBUTION SYSTEMS

The following guidelines and requirements apply to private distribution design:

1. For metered service, the private line is that portion past the meter yoke/ copper setter.
2. For unmetered service, the private line begins at the property line.
3. Design, construction and inspection of private distribution systems are coordinated through the Code Administration Division, Planning Department, according to current plumbing codes.
4. Private lines will be inspected by the Code Administration Division within the city limits and by the State Mechanical Board outside the city limits.
5. Private systems must not “loop,” that is, connect the same line to the public system at more than one point. When both private domestic distribution systems and fire protection lines are approved for the same developments, the fire protection system may be independent from the private domestic system connection.
  - a. Backflow prevention from private systems is required in accordance with the [\*Cross-Connection Prevention and Control Ordinance\*](#) as adopted by the Water Authority .
  - b. The unmetered fire line is typically public within the street right- of-way up to the public valve . After the public valve the line is considered private.
6. Backflow prevention must be provided as follows:
  - a. Backflow prevention devices are required to prevent cross-connections to the municipal water system or within premises.
  - b. Requirements for cross-connection prevention are outlined in the [\*Cross-Connection Prevention and Control Ordinance\*](#). The ordinance should be referred to for specific cross-connection prevention requirements.
  - c. At a minimum, cross-connection prevention is required in the following instances:
    - i At the service connection to any premise which is non-residential.
    - ii At the service connection to any premise which has an auxiliary water supply or private well.
    - iii At the service connection to any premise on which contaminants or pollutants are handled in such a fashion as to permit their backflow into the consumer’s water system.
    - iv At the service connection to any premise where it is physically or economically infeasible to find and eliminate or control all actual or potential cross connections.

## ARTICLE 9-9 FIRE HYDRANT CRITERIA

### Part. 9-9(A) General Information

1. Albuquerque Fire and Rescue (AFR) experience, National Fire Codes, Fire Insurance Regulations (Insurance Services Office) and Water Authority standards provide the hydrant criteria which is used to determine required protection.

2. Albuquerque’s fire prevention policies are a joint effort of the Water Authority, City Planning Department, and AFR Fire Marshal’s Office. These policies are required to:
  - a. *Attain appropriate fire protection of life and property.*
  - b. *Achieve orderly development of the fire hydrant protection system.*
  - c. *Set forth guidelines and rules for development of a fire hydrant system.*
3. Fire hydrants shall be on mains when water lines are extended, according to spacing criteria that varies according to proposed land use adjacent to the water line. These hydrants may have to be supplemented with additional hydrants when actual development takes place.
  - a. *Cases also exist where water lines have been extended through undeveloped areas or unplatted land, and hydrants were not installed at the time of water line extension. Necessary hydrants must be installed at the time of adjacent development.*
4. Fire hydrants shall be located within public right-of-way where possible. The type, layout and size of development may dictate location of fire hydrants on private property.
5. Each development must be analyzed for fire hydrant needs. Fire hydrant requirements vary with the size and layout of the buildings, building design and construction materials, and access from and proximity to the public right-of-way.
6. Where private developments require fire hydrants on private property, which benefit no other development, such hydrants shall be privately owned and maintained. Private fire hydrants are typically installed on unmetered, private fire line connections to the Water Authority’s main line. A monthly charge is assessed for private fire lines, per the Water and Sewer Rate Ordinance.

## **Part. 9-9(B) General Fire Hydrant Requirements for Fire Protection**

1. Definitions:
  - a. **Residential:** *Single family, duplexes, triplexes, and mobile homes..*
  - b. **Commercial:** *All buildings not defined above as residential.*
2. Hydrant Spacing Requirements

<b>TABLE 9.9.89 Hydrant Spacing Requirements</b>	
<b>Development Areas</b>	<b>Street Measurement, Bonnet to Bonnet</b>
<b>Residential<sup>1</sup></b>	950’ maximum between hydrants
<b>Commercial</b>	Hydrant spacing for commercial developments shall be as required by <i>IFC Appendix C</i>

**TABLE 9.9.90 Hydrant Spacing Requirements**

<sup>1</sup> *In residential areas and mobile home parks, there shall be one (1) hydrant at each street intersection with intermediate hydrants so that no one home is more than 500’ (as the fire equipment travels) from a hydrant.*

New and Existing Individual Buildings	Distance <sup>2</sup>
Residential	500'
Commercial	Hydrant spacing for commercial developments shall be as required by <a href="#">IFC Appendix C</a>

3. All Required Fire Hydrants
  - a. See [Section Part. 9-8\(C\).3](#)

## Part. 9-9(C) New Buildings, Building Additions or Building Reconstruction

This portion of the policies applies to buildings for which a City building permit is required, including new construction, additional construction, or reconstruction.

1. The AFR Fire Marshal's Office shall review development plans at or prior to the time of building plan review. The AFR shall determine the development's fire protection requirements and verify conformity with adopted City codes and criteria for fire flow quantity, and number of hydrants, location and spacing.
  - a. Development plans shall include new development, building additions and/or redevelopment.
  - b. Once fire hydrant protection requirement(s) are established in writing by the AFR Fire Marshal's Office (via [Fire Hydrant and Instantaneous Fire Flow Requirements](#) form), the Water Authority will check these requirements against the ability of the water system to provide these requirements.
  - c. If the water system can meet the requirements, then the hydrant(s) may be designed and constructed per the appropriate chapter in DPM Volume 1 (either [Public Infrastructure Improvements, Chapter 5](#) or [Private Infrastructure Improvements, Chapter 6](#)).
  - d. If the water system cannot meet the requirements, then analysis will be made by the Water Authority to determine what is necessary to rectify the situation, including developer's responsibilities if water system improvements are necessary.
2. Hydrants shall be installed in accordance with the [Standard Specifications, Standard Details](#), and policies, and shall be available for use prior to the beginning of development building construction.
3. Hydrants and fire sprinkler lines shall be installed at the developer's expense, including:
  - a. Extension of Water Authority-owned water lines in accordance with the existing Water Authority [Water and Sewer System Extension and Expansion Policies](#).
  - b. Addition of public fire hydrants to existing water lines.
  - c. Construction of private fire lines and private, on-site hydrants.
  - d. All costs of incidental items (e.g., removal and replacement of existing improvements).

<sup>2</sup> Distance is measured as the fire equipment travels from the fire hydrant to the structure. All distances given are maximums.

## **Part. 9-9(D) Existing Development and building Fire Hydrant Deficiencies**

1. The City and Water Authority shall determine deficiencies in fire hydrant protection located in public right-of-way.
2. Where existing development poses a danger to life and property due to fire hydrant deficiencies existing on private property, the AFR may require deficiency correction. The cost of this type of fire hydrant protection shall be borne by the property owner.

## **Part. 9-9(E) Public Fire Hydrant Installation Procedure**

The following procedure has been established to expedite the installation of fire hydrants required because of a subdivision or a service request and to insure proper record keeping.

This procedure eliminates the need for a design by a licensed professional engineer, the processing of a SIA, and the need for a formal DRC and Work Order Process. It is intended for use only when no other construction of public infrastructure is required and the Water Authority determines that the normal design, review, and Work Order Process is not required.

1. The owner or contractor must submit plans using the standard forms to the Water Authority for review and approval. Forms may be obtained at Development and Building Services, Plaza del Sol, 600 2nd St. NW. Plans must include: Zone Atlas page number, legal description, and location of fire hydrant(s) relative to nearest property corner or street centerline intersection. Submitter must provide:
  - a. One set of original mylar forms.
  - b. 4 copies of the original forms.
  - c. Engineering fee established for each fire hydrant or fire line.
  - d. Names and phone numbers of the project Contractor, Designer/Engineer, and Owner.
  - e. Shut-Off Plan.
2. The DRC Master Scheduler shall assign a project number to the proposed installation.
3. Upon receipt of the Engineering Fee and approval of the proposed installation, the Water Authority will forward the approved plan to the Construction Division for review and to assign a city inspector to the project.
4. The Construction Division will forward a copy of the approved plan to the owner or owner's contractor. Prior to construction, the contractor must obtain the necessary permits from the City, County and/or Village. A copy of the approved design must accompany the request for a permit. The contractor must be properly licensed and bonded to do work on the Water Authority's water system.
5. Any soil compaction, asphalt, concrete, or any material testing required by the standard specifications shall be done by the contractor at no expense to the City or Water Authority.
6. Upon construction of the fire hydrant the contractor will obtain the Water Authority Inspector's approval of the construction. The Inspector will sign

- the original which will then be forwarded to the Maps and Records Division for As-Built processing.
7. The Construction Engineer will provide the Water Authority and DRC Master Scheduler written certification that the construction has been completed and accepted.
  8. If the construction does not pass inspection and a revised design is required, then steps 2. through 6. must be reinstated. No plat will be signed or meters released until the Water Authority has accepted the construction.

## **ARTICLE 9-10 FIRE FLOW REQUIREMENTS**

1. The procedure for determining required fire flow shall be as prescribed in [\*Appendix B of the IFC.\*](#)
2. All required fire hydrants shall provide proper fire flow (minimum of 1000 gpm at minimum 20 p.s.i. residual pressure from the 4-1/2 " outlet).
3. Public fire hydrants shall be attached to Water Authority-owned water lines, which are paid for by the developers in accordance with Water Authority Water and Sewer System Extension and Expansion Policies. These hydrants are maintained by the Water Authority .
4. Private fire lines, with fire hydrants located on private property, are paid for by the property owner and are maintained by the property owner. A monthly fee is charged for private connections, per the Water and Sewer Rate Ordinance.
5. The property owner is also responsible for the cost of additional hydrants required because of new development, additional development, or redevelopment. In the event of additional development or redevelopment, the existing development is also included in the fire hydrant protection analysis, and deficiencies for both existing and new development are required to be corrected.

# CHAPTER 10

## SURVEYS AND MONUMENTATION

This chapter relates the minimum criteria, standards and acceptable procedures for establishing survey monumentation required by the Subdivision Ordinance for use by qualified, registered professionals as follows:

### **ARTICLE 10-4** CONTENTS

#### **ARTICLE 10-1 GOVERNING REGULATIONS ..... 510**

#### **ARTICLE 10-2 REGULATED CRITERIA AND APPLICATION ..... 510**

Part. 10-2(A) Monumentation.....	511
Section. 10-2(A)(1) Subdivision Control Monuments.....	511
Section. 10-2(A)(2) Permanent Survey Monuments.....	511
Section. 10-2(A)(3) Bench Marks.....	512
Part. 10-2(B) Albuquerque Geodetic Reference.....	513
Part. 10-2(C) Records Requirements.....	513

#### **ARTICLE 10-3 CONSTRUCTION SURVEYS ..... 514**

Professional judgment and responsibility are essential in the application of this material and the execution of all survey work. The degree of accuracy in the performance of survey work must be consistent with the nature and importance of the survey. Where these instructions are in conflict with the current Minimum Standards for Surveying in New Mexico, in effect at the time of the performance of the survey, the Minimum Standards for Surveying in New Mexico will govern.

The City Engineer, through the City Land Surveyor, is responsible for subdivision monumentation, the interrelationship of City control monumentation with other agencies (National Geodetic Survey, NOAA, etc.), and the recordation and perpetuation of records and monumentation for the City's Albuquerque Geodetic Reference System (AGRS). Acceptability of deferred subdivision monumentation is also his/her responsibility.

All subdivision surveys are referenced to the AGRSA network in the City of Albuquerque. The system is published online at <http://www.cabq.gov/gis/map-views/geodetic-control-and-artgn>. This publication depicts all City control monuments and data.

In general, any New Mexico Registered Professional Land Surveyor can perform most of the survey requirements for the development process; however, certain portions must be performed under the City Land Surveyor's approval and specifications.

Detailed requirements to facilitate the planning, design, construction and operation of both public and private drainage control, flood control, stormwater quality and erosion control facilities are covered as follows:

## **ARTICLE 10-1 GOVERNING REGULATIONS**

Subdivision Ordinance (Article 7-11 R.O.A. 1994). This ordinance contains the major regulations governing monumentation and surveys for subdivisions in Albuquerque. Survey, design, and construction professionals should be thoroughly familiar with the survey and monumentation requirements of this ordinance.

## **ARTICLE 10-2 REGULATED CRITERIA AND APPLICATION**

This section presents pertinent criteria and standards from the Subdivision Ordinance and appropriate design standards and application procedures established by the City Land Surveyor.

## Part. 10-2(A) Monumentation

### Section. 10-2(A)(1) Subdivision Control Monuments

6. All corners, angle points and points of curvature along the subdivision perimeter, points of curves or intersection on centerline or street rights-of-way, and intermediate points at right-of-way intersections with property lines of City property such as parks or open space, must be monumented as subdivision control monuments. In lieu of permanent subdivision control monuments, centerline monumentation may be established as permanent survey monuments with prior approval by the City Land Surveyor. A minimum of two (2) subdivision control monuments must be inter-visible and a tie to a third Permanent Survey or subdivision control monument must be assured. The surveyor setting the monumentation will be required to submit a subdivision plat of survey, notes, drawings, or other reproducible documentation of each point set for permanent files and publication. Acceptable formats are available from Albuquerque Development and Building Services Center. (DBSC)
7. Subdivision control monuments must meet the New Mexico Minimum Standards for Surveying in New Mexico in effect at the time the survey is being performed.
8. Monuments must be set flush with the earth or within 0.2 feet above and must bear a cap or permanent tag identifying the registration number of the surveyor setting the monument.
9. Subdivision control monuments shall be set only under the supervision of a Professional Land Surveyor registered in the State of New Mexico.
10. Subdivision control monuments must be set in conformance with the standards and specifications in accordance with the New Mexico Minimum Standards for Surveying in New Mexico in effect at the time the survey is being performed.

*NOTE: The developer may submit a centerline monumentation plan for approval by the City Land Surveyor. If acceptable, the monuments must be included in the street design package and will be constructed with the street improvements and will be inspected for acceptance by the City along with other street improvements at the time of final inspection.*

### Section. 10-2(A)(2) Permanent Survey Monuments

1. No point within the subdivision shall be more than one-quarter mile from a permanent survey monument, and at least two corners or points on or near the perimeter of the subdivision traverse, must be tied or monumented with Permanent Survey Monuments as approved by the City Land Surveyor. These points or monuments must be tied by Grid Bearing in the New Mexico State Plane Coordinate System (Central Zone) based on the current datum as approved by the City Land Surveyor and ground distance to the AGRS network. The location of Permanent Survey Monuments showing ties to the AGRS network together with the New Mexico State Plane Coordinates, the mapping angle, and ground to grid factor at the point or for the centroid of the parcel of the subdivided land, and the elevation related to the North American Vertical Datum (NAVD) based on the current datum as approved by the City Land Surveyor, if established, shall be shown on the final plat for which the survey is made.
2. Permanent Survey Monuments must be brass or aluminum caps set in an acceptable base. Caps shall bear the registration number of the surveyor establishing the point and identifying letters or numbers approved by the City Land Surveyor and year the monument was established. This information must be stamped permanently into the cap and must be shown on the final plat for which the survey is performed.



3. Upon the request of the City Land Surveyor, a narrative covering the equipment and procedures used along with copies of all field notes, calculations, reductions, closures and State Plane Coordinate calculations shall be submitted to the City Land Surveyor at least ten (10) days prior to submission of a final plat for review and approval. Monument information must be submitted on standard forms available from the City Land Surveyor, or on forms which are identical in format to Figures 26.5 and 26.6. Similar information, upon the request of the City Land Surveyor, shall also be submitted for any found property corners or other monuments which substantially affect the representation of evidence used for property locations.
4. Permanent Survey Monuments shall be considered properly positioned and represented only after the City Land Surveyor has approved all survey procedures, calculations, and verified conformance to standards and specifications as outlined in the New Mexico Minimum Standards for Surveying in New Mexico in effect at the time the surveying is being performed. If found to be deficient, the Land Surveyor submitting the final plat and documentation may be required to perform additional work to bring monumentation into conformance, regardless whether the final plat is recorded or not.
5. For points to be included in the AGRS, tentative point identifiers may be established by the Land Surveyor; however, only the City Land Surveyor will assign permanent point identification.
6. Permanent Survey Monuments shall be considered to have a zero positional error when controlling subdivision control monuments within the property.

**Section. 10-2(A)(3) Bench Marks**

1. Upon the request of the City Land Surveyor, at least one bench mark, located as approved by the City Land Surveyor, must be placed within each subdivision. Bench marks may be coincident with Permanent Survey Monuments, subdivision control monuments, or AGRS control monuments. Upon the request of the City Land Surveyor, more than one bench mark may be required within the perimeters of parcels or subdivisions in excess of ten (10) acres in size. Such additional bench marks will be at positions other than Permanent Survey Monuments.
2. Elevations of bench marks must be based on the current vertical datum as approved by the City Land Surveyor and as established by the U.S. Coast and Geodetic Survey, now National Geodetic Survey (NGS), and must be tied to the AGRS network.
3. Level closures, running forward and backward between fixed elevations or loop closures, must be of Third Order accuracy or better as defined in Table 26.2. Loop closures are discouraged and are only used when it is not feasible to use two separate bench marks.

<b>TABLE 10.2.91 Accuracy Standards For Level Closures 1</b>			
	<b>First Order ORDER</b>	<b>Second Order</b>	<b>Third Order</b>
<b>Metric Units</b>	4mm Sq. Rt. K	8.4mm Sq. Rt. K	12mm Sq. Rt. K
<b>English Units</b>	0.017 ft. Sq. Rt. M	0.035 ft. Sq. Rt. M	0.05 ft. Sq. Rt. M

**1** *r*Where K is the distance in kilometers; M is the distance in miles of the total level route; run-

4. Level notes and calculations must be submitted to the City Land Surveyor prior to approval of the elevation to be published for the bench mark. The City Land Surveyor will review the submitted material and determine whether the elevation is satisfactory for publication within five (5) working days after receipt of submittal.
5. Bench marks must be brass or aluminum caps as specified for Permanent Survey Monuments; set as required for the Permanent Survey Monuments. They must be identified by permanent stamping on the brass or aluminum cap as required by the City Land Surveyor.
6. All bench marks established must be shown on the final plat for which the survey was made, accurately identified as to location and character.

### **Part. 10-2(B) Albuquerque Geodetic Reference**

Complete information on existing AGRSCS network monumentation is available from the City Land Surveyor online at <http://www.cabq.gov/gis/map-views/geodetic-control-and-artgn>. in the form of the City of Albuquerque Survey Monuments book. The City Land Surveyor will provide information on any Permanent Survey Monument of the AGRSCS network within one (1) mile of the subdivision upon request. Should the City Land Surveyor be unable to provide such information within three (3) weeks after requested, the plat data may be referred to a substitute system approved by the City Land Surveyor.

### **Part. 10-2(C) Records Requirements**

Land Survey Monument Record, a form available from Albuquerque Development and Building Services Center must be filled out and submitted to the City for all found property corners used in establishing survey control, all property corners found but of questionable position and not used for survey control, and for all set corners (excluding interior subdivision lot corners) which positionally determines the perimeters of land ownership, Middle Rio Grande Conservancy District Tracts, public right-of-way and Bureau of Land Management sectionalized positions thereby establishing a continuous history of existing property corners. Any corners not so described must be fully described on the plat.

---

*ning forward and back between fixed elevations or along a level loop.*

## **ARTICLE 10-3 CONSTRUCTION SURVEYS**

The physical staking for the contractor's work in the construction phase of any project is the responsibility of the developer on a privately financed project. Either the developer or the City, depending on the agreement with the City Engineer, may be responsible on projects which involve City master planned facilities.

The Registered Professional Land Surveyor certifying the plat for a project must provide Permanent Survey Monuments for at least two (2) critical points on the boundary; one or more permanent elevation control bench marks and the required subdivision control monuments.

1. It is the responsibility of the Registered Professional Surveyor performing construction staking (establishing grades and positions for improvements) to confer with the design engineer whose seal and statement appear on the approved construction plans prior to such staking activities.
2. The Registered Professional Surveyor performing construction staking is also responsible for conferring with the Registered Professional Surveyor who certified the plat, prior to construction staking.
3. The Registered Professional Surveyor performing construction staking must satisfy himself as to the accuracy of subdivision controls and to the intent of the construction plans, as they relate to positions and elevations prior to the commencement of work.
4. The developer must reasonably assure himself that the person(s) intending to provide construction staking have an understanding of the intent of the plans, conditions of control monuments and that construction surveying will be under the supervision of a Registered Professional Land Surveyor.
5. The contractor is responsible for protecting and maintaining all plat and monumentation controls set by the Registered Professional Land Surveyor. In the event of inadvertent destruction or alteration, the contractor must immediately notify the Registered Professional Land Surveyor and the City Land Surveyor.

# CHAPTER 11

## LANDSCAPE AND IRRIGATION

This chapter presents the standards established for landscape and irrigation within the City of Albuquerque Right-Of-Way. Detailed requirements are covered as follows:

### **ARTICLE 11-7 CONTENTS**

<b>ARTICLE 11-1 GOVERNING REGULATIONS .....</b>	<b>516</b>
<b>ARTICLE 11-2 GENERAL DESIGN CRITERIA .....</b>	<b>517</b>
Part. 11-2(A) General Design Criteria: Medians .....	517
Part. 11-2(B) General Design Criteria: Medians .....	518
<b>ARTICLE 11-3 IRRIGATION DESIGN CRITERIA.....</b>	<b>518</b>
Part. 11-3(A) Irrigation Design Criteria: Medians .....	518
Part. 11-3(B) Irrigation Design Criteria: Medians.....	519
<b>ARTICLE 11-4 PLANTING DESIGN CRITERIA .....</b>	<b>520</b>
Part. 11-4(A) Planting Design Criteria: Medians .....	520
Part. 11-4(B) Planting Design Criteria: Medians.....	520
<b>ARTICLE 11-5 REFERENCE.....</b>	<b>520</b>
<b>ARTICLE 11-6 GREENSPACE INITIATIVE .....</b>	<b>521</b>
Part. 11-6(A) Greenspace Initiative Intent.....	521
Part. 11-6(B) Greenspace Initiative .....	521

## ARTICLE 11-1 GOVERNING REGULATIONS

Following are overviews of several of the most important City regulatory documents pertaining to landscape design in the Public Right-of-Way. The list is not intended to be exhaustive, and the user is cautioned that these regulations are subject to change at any time. The designer must maintain a constant familiarity with these and other pertinent regulations as they evolve.

Refer to Chapter 23 of the DPM for American Association of State Highway and Transportation Officials requirements.

1. [Comprehensive City Zoning Code \(Article 14-16 R.O.A. 1994\)](#)
  - a. This document contains important regulations relating to landscape requirements, obstructions of sight distances within the right-of-way, and proximity of landscape elements to the traveled way.
2. [Landscape Ordinance \(Article 7-14-40 R.O. 1974\)](#)
  - a. This Ordinance includes, among other requirements, the requirement for the installation of landscaping to provide a visually attractive streetscape.
3. [Street Tree Ordinance \(Article 6-6 R.O.A. 1994\)](#)
  - a. This Ordinance requires the installation of trees along major streets.
4. [Regulations for Street Tree Planting \(EPC Resolution, adopted February 10, 1983\)](#)
  - a. These regulations are companion to the Street Tree Ordinance and govern plantings encouraged or required by the Ordinance.
5. [Water Conservation Landscaping and Water Waste Ordinance \(Article 6-1 R.O.A. 2015\) and the Albuquerque Bernalillo County Water Utility Authority \(Section 4\)](#)
  - a. This Ordinance requires the implementation of water conservation measures to reduce water use and reduce water waste.
6. [City of Albuquerque Standard Specifications for Public Works Construction](#)
  - a. The current addition is to include updates and the Standard Details.
7. [Greenspace Initiative](#)
  - a. The Greenspace Initiative's intent is to encourage long term sustainable landscaping within the public right-of-way. The maintenance of public right-of-way landscape, which meets the Greenspace Initiative, DPM, and City of Albuquerque Department's requirements, shall be assumed by the City's department responsible for maintenance after a two (2) year maintenance period. The DPM Chapter 28, Section 6, outlines requirements of the Greenspace Initiative.

## ARTICLE 11-2 GENERAL DESIGN CRITERIA

### Part. 11-2(A) General Design Criteria: Medians

Landscaping within the Public Right-of-Way shall meet the criteria cited in this chapter of the DPM, or as approved by the [City of Albuquerque](#) department responsible for maintenance.

Medians are defined as public right-of-way areas that provide a separation of traffic.

The City of Albuquerque, City Engineer or designee reserves the right to inspect irrigation and landscaping improvements within the Public Right-of-Way.

A 4" depth of gravel mulch shall be installed throughout the landscape areas with minimum four ounce, needle punched polypropylene weed barrier fabric under or as approved by the City of Albuquerque department responsible for maintenance. Fabric ends shall be overlapped 3". Edges of fabric shall be turned down 6". Top of landscape mulch shall be 1" below top of adjacent curb and/or sidewalk. Gravel shall be a 'warm tone' color (brown or brownish-red) or as approved by Department responsible for maintenance. Sizes of gravel may vary.

Boulders shall be 12 CF to 18 CF moss rock, or as approved by Department responsible for maintenance, buried min. 6" below bottom of gravel mulch.

Height of boulders shall not exceed the following:

1. Within six feet of back of Curb: maximum 8" height above top of curb
2. Six to twelve feet from back of curb: maximum 16" height above top of curb
3. Over twelve feet from back of curb: maximum 24" height above top of curb

The above height restrictions also apply to decorative landscape walls within the right of way.

No turf grass shall be permitted within the right-of-way.

A swale shall be provided continuously along the length of median to retain water within the landscape areas. Soil at back of curb shall remain undisturbed for a minimum width of 1'-0". Maximum slope on the sides of the swale shall be 10% gradient. Maximum depth of swale shall be nine inches below top of curb. Where there is an existing utility structure (manhole, pull box, etc.) within the area of a swale, it is acceptable to feather the grade at the swale to ensure that top of mulch is flush with top of utility structure. Gradient on feathered grade shall not exceed 1:5.

## **Part. 11-2(B) General Design Criteria: Medians**

In addition to the design criteria described in [Part. 11-4\(A\)](#), landscape within medians shall be in accordance with the following:

A parking area dedicated for maintenance vehicles shall be provided adjacent to the irrigation controller. Parking area shall be 23' length, 12' width with 12' wide flares on each side. Parking area shall be integrally colored concrete (beige-tone), 6" thick.

The parking areas on medians with a width of less than 12' shall be defined by the City's Department responsible for maintenance.

Median noses shall be paved with colored concrete (beige or tan tone) with a broom finish and troweled edges at joints and perimeter.

Medians less than 6' wide shall be paved with colored concrete (beige or tan tone) with a broom finish and troweled at joints and perimeter.

## **ARTICLE 11-3 IRRIGATION DESIGN CRITERIA**

### **Part. 11-3(A) Irrigation Design Criteria: Medians**

An automatic irrigation system shall be provided for the landscape improvements.

Automatic control valves shall be Rain Bird PEB plastic body automatic valve or as approved by the City of Albuquerque Department responsible for maintenance.

All valves shall be installed in valve boxes per City Standard Drawings.

Valve boxes shall be located so edge of valve box is minimum two feet from the edge of the mature spread of a shrub and minimum six feet from the edge of a tree root ball.

Valve boxes and lids shall be tan color.

A minimum of 36 inches shall be provided between adjacent valve boxes.

Irrigation system shall be a bubbler system. Drip and/or spray irrigation is not acceptable. Bubblers shall be as follows:

1. Tree: 3 each 1.0 GPM bubblers (See note below regarding bubblers at trees.)
2. Vertical Shrub: 2 each 0.5 GPM bubblers
3. Shrub: 1 each 0.5 GPM bubbler

4. Yucca and other very low water-use shrubs: 1 each 0.25 bubbler

Bubblers shall be located three feet from the center of the tree trunk, triangulated around the root ball. Where a tree is located on a slope, two of the bubblers shall be located on the high side of the tree. (Note: If a landscaped area is too narrow to triangulate three bubblers around the root ball, two bubblers shall be installed, one on each side of the root ball. Where a tree is located on a slope, the two bubblers shall be located on the high side of the tree.) Bubblers shall be located 12" to 18" from the center of the shrub. Where a shrub is located on a slope, bubblers shall be located on the high side of the shrub.

Where there are significant changes in elevation, in-line check valves shall be installed on lateral lines as required to evenly distribute low head drainage.

An air relief valve shall be installed at each high point on the main line.

### **Part. 11-3(B) Irrigation Design Criteria: Medians**

In addition to the design criteria described in Section 3.1, irrigation within medians shall be in accordance with the following:

The irrigation system shall be independent of other properties and shall have dedicated utilities. Irrigation system shall connect to a public water system non-potable line if available and if reliably charged.

Irrigation system shall have a cross connection device, installed and located in accordance with City and Water Authority standards.

Backflow preventer enclosure shall be a 'Hot Rok' or equal insulated enclosure, with heat tape and electrical power, hinged lid, clasp for lock and L-shaped metal clasp reinforcement. Backflow preventer and enclosure shall be installed in accordance with City Standard Drawings.

Irrigation controller shall be in accordance with current City standards and as approved by the City of Albuquerque Department responsible for maintenance.

Irrigation controller shall be installed in a UL rated enclosure per [City standards](#) or as approved by the City of Albuquerque Department responsible for maintenance. Enclosure shall be powder coated, color tan. Enclosure shall be mounted on a 6" thick slab of concrete with 4" wide lip on all sides, sloped away from the controller enclosure.

A master valve and flow sensor shall be provided per City standards and installed per [City Standard Drawings](#). Communication wire for the flow sensor shall be black communication cable (with internal control wire and ground) dedicated to the flow sensor.

Electric service shall be provided to the irrigation controller and backflow preventer or as approved by Department responsible for maintenance.



The irrigation controller, backflow preventer and related equipment shall be located adjacent to the designated maintenance parking pad on the side of oncoming traffic.

Main line and lateral lines shall be located a minimum of five feet away from trunks of trees.

One bubbler shall be installed at each grounding rod at the irrigation controller.

## **ARTICLE 11-4 PLANTING DESIGN CRITERIA**

### **Part. 11-4(A) Planting Design Criteria: Medians**

1. Trees shall be minimum 2" caliper, installed per City Standard Drawings.
2. Shrubs shall be minimum 1 gallon, installed per City Standard Drawings.
3. Minimum distance between mature spread of shrubs shall be 2'-0"
4. Minimum distance between a tree and the edge of a manhole collar shall be 8'-0"

### **Part. 11-4(B) Planting Design Criteria: Medians**

1. Planting within medians shall be in accordance with the following:
  - a. *All median landscapes shall be pursuant to the current prototype design templates and master plant list, as maintained by the City of Albuquerque Department of Municipal Development (COA DMD). The templates and plant list are subject to change at any time. The designer must verify the current design templates and plant list with COA DMD and must maintain a familiarity with these and other pertinent regulations as they evolve. The plant list is not intended to be exhaustive. Other species may be used, if approved by the City of Albuquerque Department responsible for maintenance.*
  - b. *Trees shall be set back minimum 6'-0" from back of Curb.*
  - c. *A minimum two foot clear zone (area free of mature spread of shrubs and other improvements) shall be provided at back of curb.*

## **ARTICLE 11-5 REFERENCE**

Any questions regarding Chapter 28 are to be directed to the City of Albuquerque Department of Municipal Development, CIP Official.

## **ARTICLE 11-6 GREENSPACE INITIATIVE**

### **Part. 11-6(A) Greenspace Initiative Intent**

The Greenspace Initiative's intent is to encourage long term sustainable landscaping within the public right-of-way, and assist in the reduction of climatic and environmental challenges by building with nature. The components of the Greenspace Initiative include stormwater management, climate adaptation, improved economic development, reduction in heat stress, biodiversity, increased air quality, reduced energy use, cleaner water, and increased quality of life. Green infrastructure also serves to provide an ecological framework for social, economic and environmental health of the surroundings.

### **Part. 11-6(B) Greenspace Initiative**

The City of Albuquerque Department responsible for maintenance will assume maintenance of public right-of-way landscape, in which it meets DPM and Department responsible for maintenance requirements, is approved as part of the City of Albuquerque Department responsible for maintenance's Greenspace Initiative, and is maintained to City Standards by the responsible party for a period of two (2) years from the date of completion. The landscape shall be subject to City inspections. Deficiency documented by the City Engineer or designated inspector shall be corrected by the responsible party within thirty (30) days of receipt of written "Notice of Noncompliance". On the conclusion of the two (2) year maintenance period the responsible party shall schedule a final turnover inspection with the City of Albuquerque Department responsible for maintenance. Upon the Department responsible for maintenance's verification that the landscape meets requirements, utilities are current, and the expiration of the two (2) year maintenance period, the Department responsible for maintenance will issue of a "Letter of Acceptance" acknowledging the City's receipt of utilities and maintenance responsibilities.

The Department responsible for maintenance and DPM Executive Committee may provide exceptions to the DPM Greenspace landscaping requirements within the Public Right-of-Way to meet other requirements, and or needs

deemed by the Department responsible for maintenance to be integral component of the development.