

# **FAULT FINDING, MAINTENANCE AND DIAGNOSTIC SKILLS**



## General Principles of Fault Finding

In this section we look at the general principles of fault finding through the application of diagnostic reporting. These principles apply in all disciplines regardless of whether they are civil, electrical, mechanical etc.

### Principles of Systematic Fault Diagnosis

Diagnosis of faults requires a logical and disciplined approach. Frequently, past experience or detailed knowledge will help. Also an intuitive approach can be used but must be accompanied by a deductive technique. Faults can be classified as:

- Positive fault – sustained fault
- Intermittent fault – irregular, harder to find

### Tools for the Job

Your standard of work is related to the quality and completeness of the tools available to you. Traditionally this has been:

- Trade skill
- Knowledge of plant
- Problem solving ability

Today your ability to diagnose and repair faults largely depends on levels of documentation and test results.

### Documentation

Documentation should be:

- Aimed at the level of the maintenance
- Structured in a standard format
- Logical, precise and factual – no irrelevant material

### Test Facilities

Facilities for testing equipment are often limited. However it is desirable that plant users specify (when able to) what is required to make the system maintainable by means of diagnostic methods. Plant manufacturers will often build test points into the system. To do so later becomes very expensive. Built in test facilities are generally for first line maintenance staff, such as lamps, pressure gauges, multi meters etc.

### The Logical Diagnostic Process

Experience shows, paradoxically, that the faster a maintainer acts to identify a fault the more likely that he/she:

- fails to find it
- disguises it
- makes it worse

The first golden rule of fault diagnosis therefore is:

**STOP AND THINK**

Consider the problem then collect and evaluate the facts. The fundamental steps in the logical diagnostic process for all type of equipment are:

- |                          |                          |
|--------------------------|--------------------------|
| (1) Symptom analysis     | (2) Equipment Inspection |
| (3) Fault stage location | (4) Circuit checks       |
| (5) Repair or replace    | (6) Perform test         |

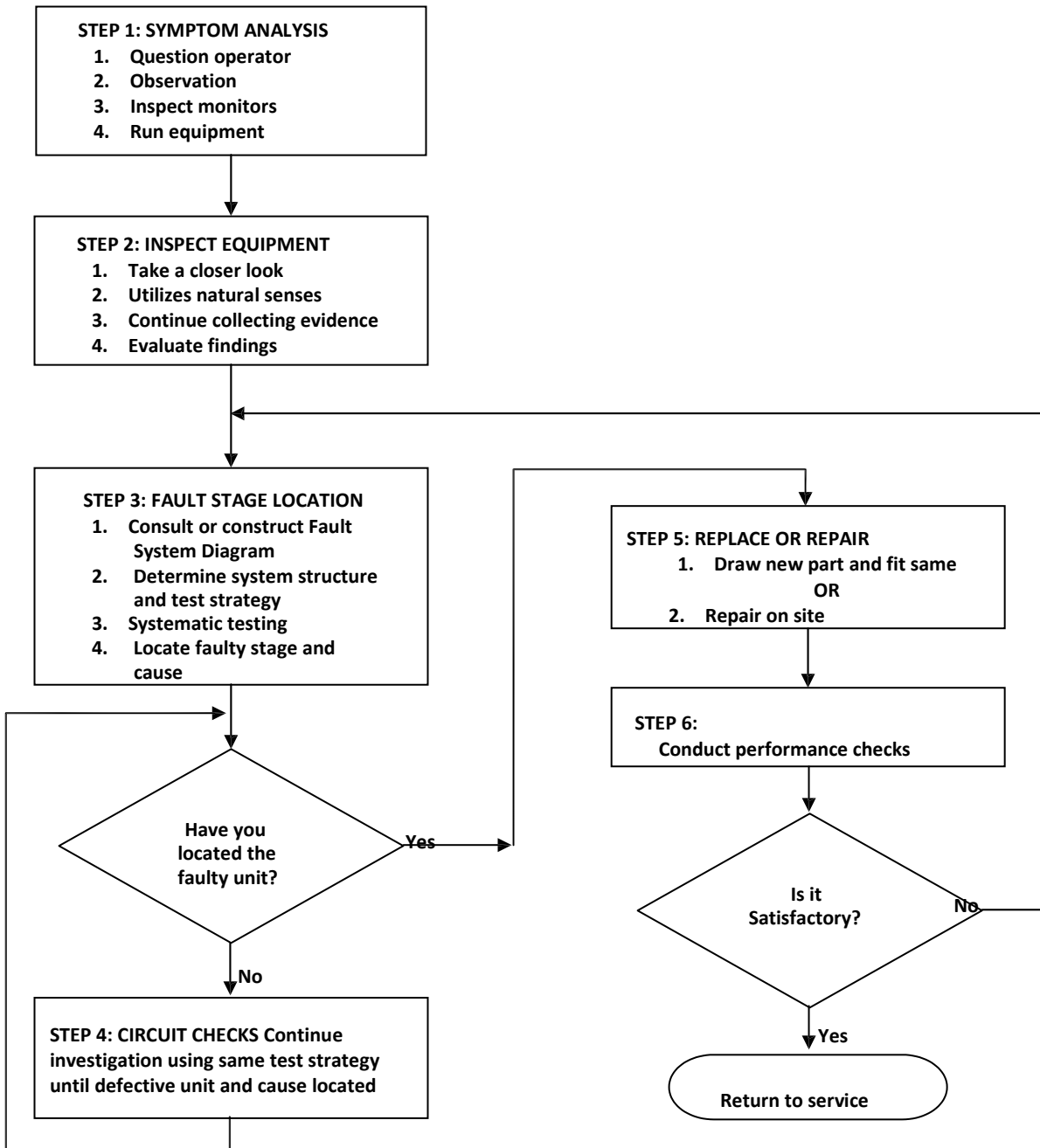

Figure 1. Diagnostic process flow chart

# Electrical Safety

Electrical Troubleshooting can be hazardous. Ensure you take the proper precautions. Electricity has long been recognized as a serious workplace hazard, exposing employees to electric shock, electrocution, burns, fires and explosions.

## Troubleshooting Regulations

There are numerous regulations, which have been developed to keep the worker safe while on the job. These regulations, which are typically developed by government and other regulatory bodies, can vary from region to region depending on the jurisdiction and even from company to company. Be sure you are familiar with the regulations that apply to you some of the things these regulations may address are:

- What distance you must maintain from live electrical apparatus. This distance is dependent on the voltage level and training.
- What type of safety equipment must be worn when performing certain troubleshooting tasks?
- What type of test equipment must be used and under what conditions.
- What special work procedures are required to perform various tasks?
- What training is needed to perform various tasks? For example, a person with specific training is allowed to be closer to live electrical apparatus than an untrained person.

## Troubleshooting Hazards

Troubleshooting can introduce many new safety concerns especially when inspecting equipment that is energized. Testing often requires the troubleshooter to temporarily connect test instruments to “live” terminals, which may involve opening enclosures or cabinets that normally are locked or bolted closed to protect workers. This introduces two main hazards:

1. **Shock Hazard.** If you were to contact live equipment with your body or a tool you are holding the current flowing through your body could cause severe injury, burns, and even death.
2. **Flash Hazard.** If you are in the vicinity of equipment that fails and causes an electric arc, the flash, heat and shrapnel caused by the arc can also be life threatening.

## 1. Shock Hazard

### *What causes shocks?*

Electricity travels in closed circuits, normally through a conductor, but sometimes a person’s body an efficient conductor of electricity mistakenly becomes part of the electric circuit. This can cause an electrical shock. Shocks occur when a person’s body completes the current path with:

- both wires of an electric circuit;
- one wire of an energized circuit and the ground;
- A metal part that accidentally becomes energized due, for example, to a break in its insulation.

When a person receives a shock, electricity flows between parts of the body or through the body to a ground or the earth.

### **What effect do shocks have on the body?**

An electric shock can result in anything from a slight tingling sensation to immediate cardiac arrest.

The severity depends on the following:

- the amount of current flowing through the body,
- the current’s path through the body,
- the length of time the body remains in the circuit, and
- the frequency of the current

The following table shows the general relationship between the amount of current received and the reaction when current flows from the hand to the foot for just 1 second.

### **Physiological Effects of Current on the Body**

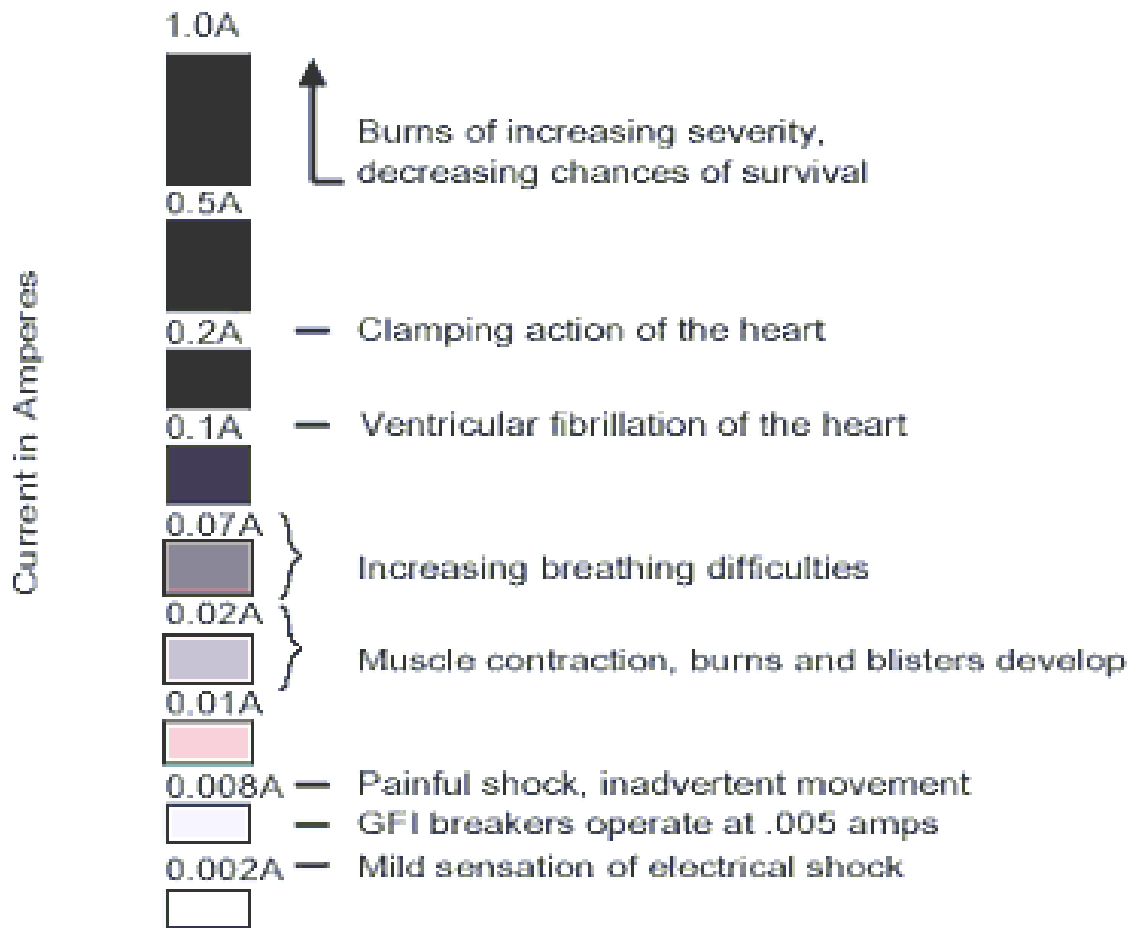

## Protecting Against Shock Hazards

Electrical equipment is generally designed to minimize electrical hazards. This is normally done through:

- The use of guards and barriers,
- Grounding of equipment cases
- Use of proper insulation
- Installation of protective electrical devices

However, the hazards cannot be totally eliminated. You may have to replace equipment, open an enclosure or even perform tests on live equipment.

In order to protect you from these hazards, safe work practices have been developed. Some examples are:

- de energizing electric equipment before inspection or repair,
- keeping electric tools properly maintained,
- exercising caution when working near energized lines And
- Using appropriate protective equipment.

Following safe work practices is an important way that you can protect yourself from electrical hazards.

### Lockout/Tag out

One work practice that is extremely important to the trouble-shooter because of the testing and repair work performed is Lockout/Tag out. Here is what OSHA says about Lockout/Tag out.

Proper lockout/tag out procedures protect you from the dangers of the accidental or unexpected start-up of electrical equipment and are required for general industry by OSHA (Occupational Safety and Health Authority) Standard 1910.333, Selection and Use of Work Practices. Requirements for construction applications are in 29 CFR 1926.417, Lockout and Tagging of Circuits. These procedures ensure that electrical equipment is de energized before it is repaired or inspected to protect you against electrocution or shock.

The first step before beginning any inspection or repair job is to turn the current off at the switch box and padlock the switch in the OFF position. This applies even on so-called low-voltage circuits. Securely tagging

the switch or controls of the machine or equipment being locked out of service clarifies to everyone in the area which equipment or circuits are being inspected or repaired.



Only qualified electricians who have been trained in safe lockout procedures should maintain electrical equipment. No two of the locks used should match, and each key should fit just one lock. In addition, one individual lock and key should be issued to each maintenance worker authorized to lock out and tag the equipment. All employees who repair a given piece of equipment should lock out its switch with an individual lock. Only authorized workers should be permitted to remove it.

## 2. Flash Hazards

If you are familiar with electric arc welding, then you are aware that the small arc created by the welding equipment can generate enough heat to melt metal as well as generate enough UV rays to burn your skin. In the case when electrical equipment fails causing an electrical arc, the energy released during the arcing can be many, many times greater than the welding arc and can cause severe flash burns. The burns fall into one of three categories:

- **First Degree:** the outer skin layer is damaged, it is painful, but since the growth areas are not damaged, the skin is quickly regrown and no scarring is left.
- **Second Degree:** the outer skin layer is severely damaged and blistering usually occurs. Healing is much longer as it occurs from the deeper sweat glands and hair follicle areas. Scarring is often the result.
- **Third Degree:** complete destruction of the skin and growth areas. If the burn is small healing may occur from the sides, however skin grafting is usually required.

### Protecting Against Flash Hazards

Hard hats, safety glasses, gloves and work boots with electrical insulation rating give the worker protection during normal work, however in the event of circuit or switchgear failure resulting in a thermal arc being created, much greater protection is required.

The following is some general information on protecting against flash hazards. Be sure to **review the appropriate legislation and your company policies** before attempting to work near live electrical apparatus.

- **Flash Protection Clothing**

Clothing can be made from many different materials. These materials have an **Arc Thermal Performance Exposure Value (ATPV)** associated with them which is defined as the amount of heat energy that the fabric will handle deflect or absorb. Some of these materials offer better protection against the heat caused from an arc than others.

#### Here are some examples

- Synthetic material like nylon, rayon or polyester should never be worn when working on or near energized electrical equipment because it is flammable and has a tendency to melt and stick to skin when exposed to high temperatures.
- Cotton blends with synthetic material should not be worn near electrical equipment for the same reasons.
- Pure cotton provides a minimum barrier to arc temperatures, but can ignite quickly. It does

burn and fall away rather than stick to the skin.

- Materials like cotton or cotton blends treated with a flame retardant chemical provide a minimum level of flame resistance. Some chemical treatment degrades with repetitive laundering.

In general, all clothing including undergarments should be 100% cotton. Flame resistant clothing should then be worn over this when working on or near energized electrical equipment. When combined in layers, the fabrics gain significant rating from the air space between them, and multiple layers have much higher ratings than the sum of the individual ratings.

### • Safety Glasses

For normal work clear lenses are adequate, however for flash protection like that required for live work, troubleshooting, switching and applying or removing grounds, then flash rated eye protection is required. In some cases full face protection is required.

### • Other PPE (Personal Protection Equipment)

Other specialized personal protective equipment may be required when performing work where a flash hazard is present. Some examples are: fire resistant hard hat liner, leather gloves, hearing protection and leather work shoes.

### • Identifying Shock and Flash Hazards

Before working on or even opening an electrical enclosure you should know what the hazards are and how to protect against them. Some regulations are now requiring that all enclosures are labelled with the level of protection required and distanced to maintain when working on or near equipment contained in an enclosure. An example is shown here.

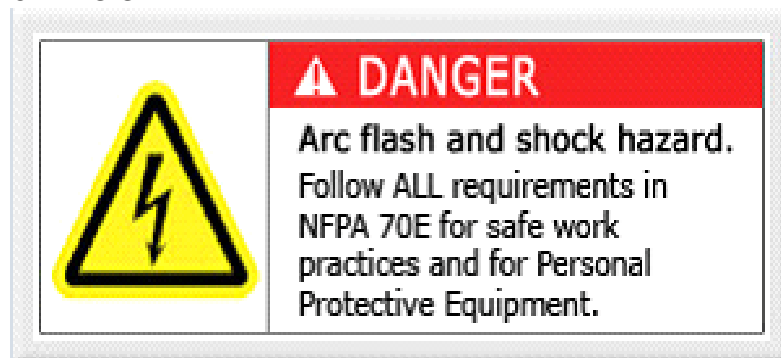

Some types of labelling also show the following information:

- Flash Hazard Boundary
- Cal/cm<sup>2</sup> Flash Hazard at 18 inches
- PPE level (what type of personal protective equipment is required)
- Approach Boundaries to Live Parts for Shock Protection.

### A Final Note:

Here are some tips to help you safely troubleshoot electrical equipment:

- Be informed, be aware of the Hazards, Make sure you know and understand all the rules and regulations that apply to the work you are doing. These can be governmental regulations or policies and procedures produced by your company.
- Follow all safety rules and procedures, these are designed to protect you. Don't take short cuts.
- Use the troubleshooting simulator in this program to practice your troubleshooting skills in a safe environment.
- Wear all required personal protective equipment, In the event of equipment failure or accidental contact, your personal protective equipment may save your life.

## Fault finding procedures

Having established the symptoms of a fault it is then necessary to conduct tests to confirm the symptoms and to attempt to determine the location of the fault within the equipment. A sound knowledge of the technical concepts and the operation of the system may assist in locating the fault but sometimes the testing will be extensive and an overall procedure should be adopted.

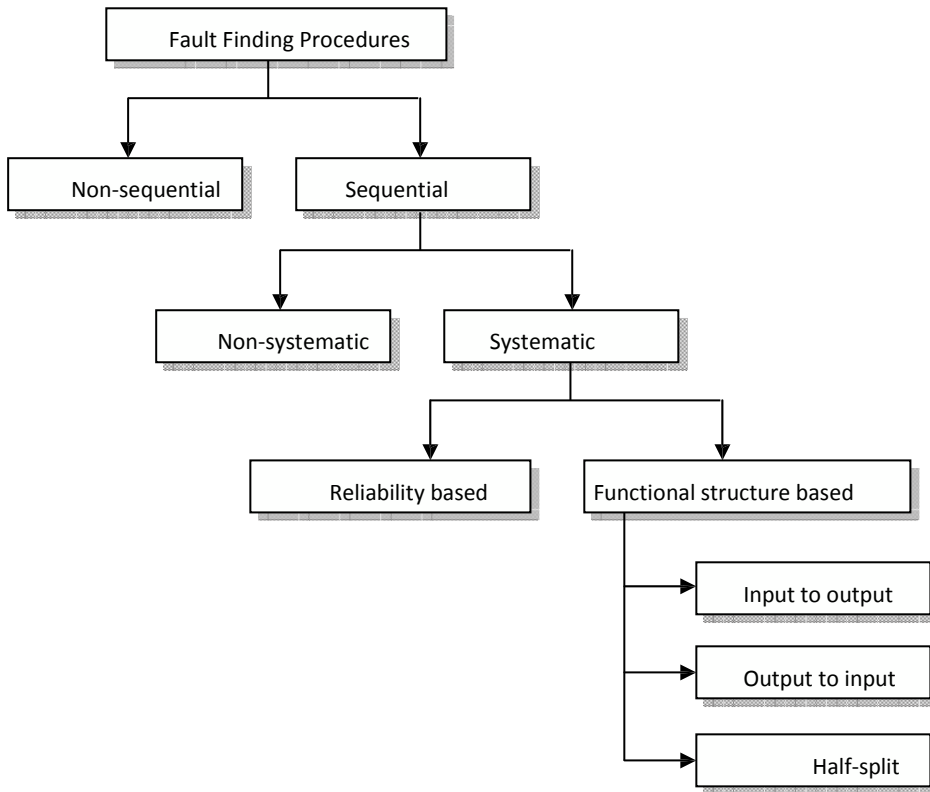

Figure 8. Fault finding procedures

## Basic Testing Techniques

### The Multimeter

Once you have determined the most probably cause of a fault, you must either prove it to be the problem or not. This can sometimes be done by careful inspection but in many cases the fault will be such that you cannot identify the problem component by observation and analysis alone.

Here, test instruments can be used to help narrow the problem area and identify the problem component.



### General Meter Rules

There are many types of test instruments used for troubleshooting. Some are specialized instruments designed to measure various behaviors of specific Equipment. There are other types of test instruments such as multimeters which are more general in nature and can be used for most electrical measurement. A typical multimeter can measure AC and DC Voltages, Resistance and Current.

Before you use a meter to make a test you should know what the meter will read if the circuit is operating normally. You should make your prediction of the reading expected, based on the circuit schematic. If the reading is anything other than your predicted value, you know that this part of the circuit is being affected by



the fault.

You should always check the meter before using it to troubleshoot.

- For a voltmeter, test the meter on a known voltage source before using. Your meter should read the correct voltage.
- For an ohmmeter, touch the meter leads together. The display should read 0 ohms or very near this. With the leads apart it should read OL (infinity).

### Meter Precautions

Here are some more Do's and Don'ts for using a meter.

- Be familiar with its features. Read the instruction manual before using.
- Ensure it is safe to use – no obvious damage to the meter or the meter leads.
- Be sure the test leads are in the correct sockets and the rotary switch is in the correct position for the desired measurement.
- Never measure resistance in a circuit when power is applied.
- Never apply more than the rated voltage between any input jack and ground.
- Keep your fingers behind the finger guards on the test probes when making measurements.
- To avoid false readings, which could lead to possible electric shock or personal injury, replace the battery as soon as the battery indicator appears.

### Testing Live vs. Dead

One of the first things you must decide is whether the circuit can be alive or must be dead while testing. Performing certain tests while a circuit is alive can be very helpful. However, some companies have policies that ban (or restrict) testing live circuits while troubleshooting. Before doing any testing make sure you check your company's policy. This module does contain certain techniques used to test a de-energized circuit.

### Types of Faults

Faults can generally be categorized into either **open circuits** or **short circuits**. Open circuits occur when there is a break in the circuitry. This could be a broken wire, loose connection, burned out component, etc. Short circuits occur when two or more components, which should be isolated, come in contact with each other. For example, the insulation on wiring could decay and the conductors short together or short to ground

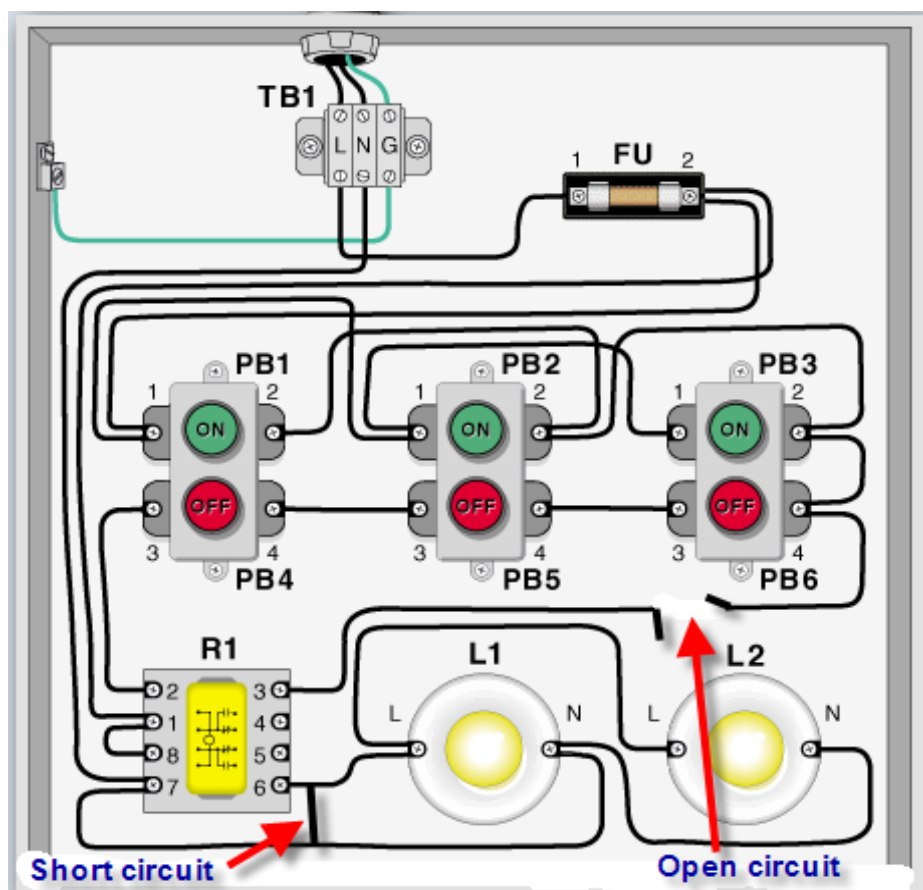

## Sectionalizing Circuits with Meters

Sometimes you will be faced with a problem that there are few useful observations and the problem area is a large portion of the circuit. It may not be feasible to begin testing all the components in the problem area. You should still start with the component you identified as the most probable cause. If this component is not the actual cause, the meter readings will provide you with information that reduces the size of the problem area and points you in the direction of the fault. This is called sectionalizing. The meter techniques described in this section use this concept in determining where to test.

### Using a Voltmeter

Voltmeters are the best tool to use for finding **open circuits – if you can safely turn the power on**. Once you know it is an open circuit and have determined the general area of the fault, get your voltmeter out and check that it is working on a known source.

Connect the negative lead to a known reference. The negative (neutral or ground if on AC) supply is preferable. Test through the affected circuit with your other lead, making sure all necessary switches are closed. The wire or device between the last point you test full voltage and the first place you don't get full voltage is where the open circuit is located.

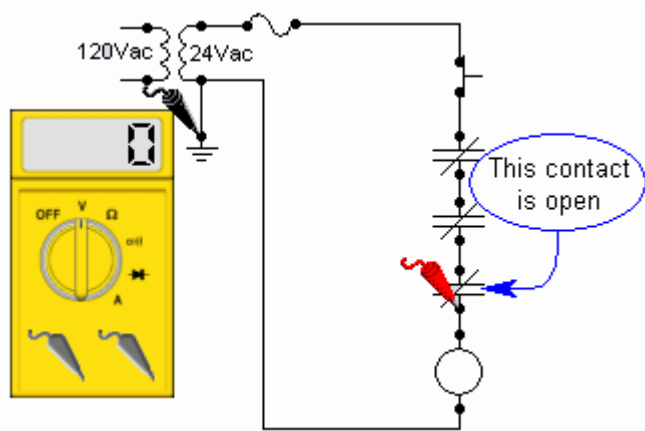

Don't forget about checking the neutral path. When you get full voltage at the positive terminal of a device that is supposed to be operating and isn't, don't stop! Carry on through the return path (Negative or neutral).

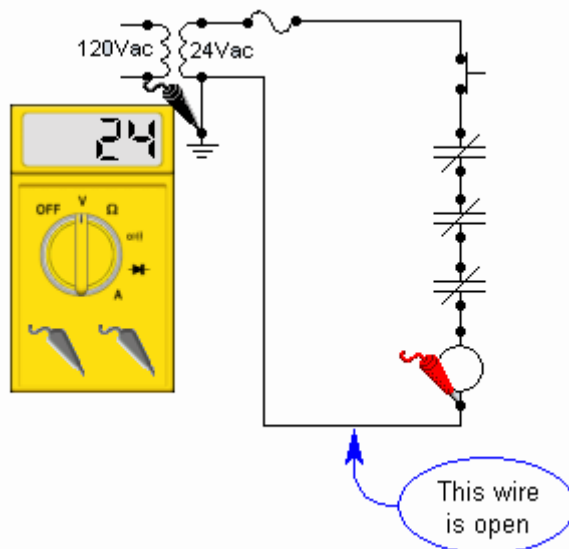

## Using an Ohmmeter

When using an ohmmeter you must first **shut off** and **lock out** the power supply.

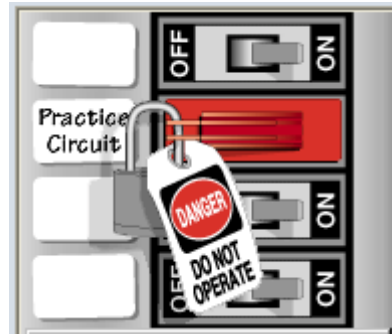

Using a connection wiring diagram, determine the location of the component which you feel is the most probable cause. Next disconnect a wire from the component which will eliminate possible parallel paths and then test for continuity. You should be careful to identify any wires you disconnect and be sure they are reconnected in the proper locations. When making your tests you should connect one meter lead to either side of the open point and then test across the component, or to ground.

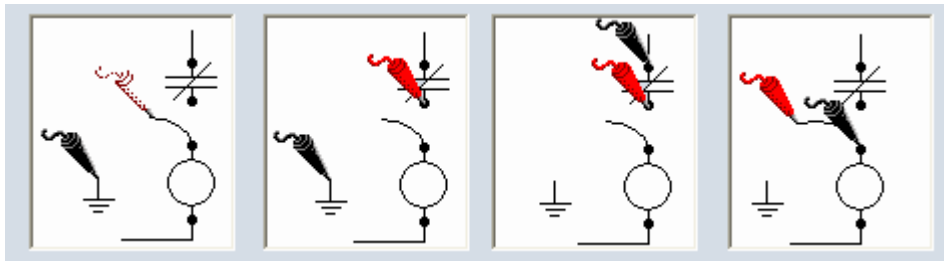
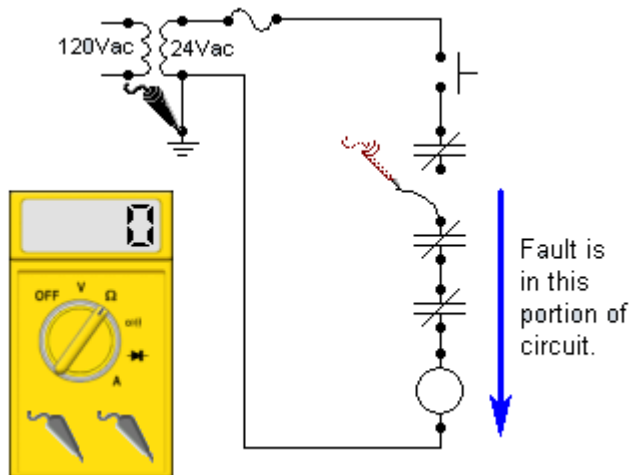

Fig-Some Ohmmeter Connection Options

## Using an Ohmmeter to find Short Circuits

**Short circuits** allow voltages and currents to flow in the wrong parts of a circuit, which causes malfunctions. These tend to be easier to find with an ohmmeter. The most common type of short circuit is a short to ground.

To find this type of fault, first **lock out** the circuit. Next disconnect and remove a wire at the component you have identified as your most probable cause. Then connect one lead of the ohmmeter to a ground point and the other lead to the suspected component. If your meter reads **very low**, then the fault is below the open point. Otherwise the fault is above the open point.



Reconnect the wire and disconnect another in the direction of the fault. Take the readings, Continue this

process until the meter no longer sees the fault. The last component tested is therefore the cause of the fault.

### Using an Ohmmeter to find Open Circuits

Sometimes you can't energize a device for testing even though the fault is an **open circuit**. Here, you have to use an ohmmeter.

To find this type of fault, first **lock out** the circuit. Next disconnect and remove a wire at the component you have identified as your most probable cause. Then connect one lead of the ohmmeter to a ground point and the other lead to the suspected component. If your meter reads **infinity**, then the fault is below the open point. Otherwise the fault is above the open point.

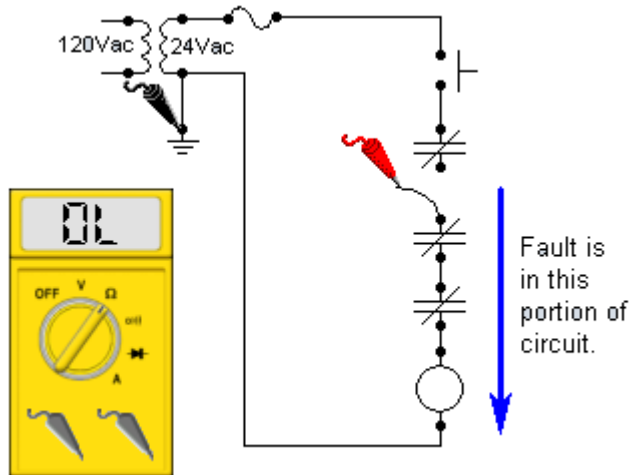

Reconnect the wire and disconnect another in the direction of the fault. Take the readings. Continue this process until the meter no longer sees the fault. The last component tested is therefore the cause of the fault.

### Using an Ammeter

With an ammeter, you can measure the current flowing through a circuit. This can be very useful when your other test instruments (voltmeter and ohmmeter) are not appropriate. For example, measuring the current in each phase of a 3 phase motor can provide very important clues as the motor behavior.

There are two ways to use an ammeter.

The first way is to connect the meter leads into the appropriate sockets on the meter and then insert the meter into the circuit. To do this you must first lockout the circuit, disconnect a terminal where you want to test and then connect the leads between the terminal and the wire as shown. When using this method you must be sure that the current you are about to measure will not exceed the maximum value for the meter.

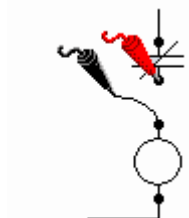

Another option for measuring current (AC current only) is to use a clamp-on probe instead of the meter leads. One end connects into the appropriate sockets on the meter and the other end consists of a spring operated circular clamp, which can be clamped around a wire. The clamp is really a small transformer that can sense the current flowing through the wire and send this information to the meter to be displayed. This type of reading has the advantage that you do not need to disconnect any wires in the circuit. This type of ammeter is used in Smutch's troubleshooting simulators.

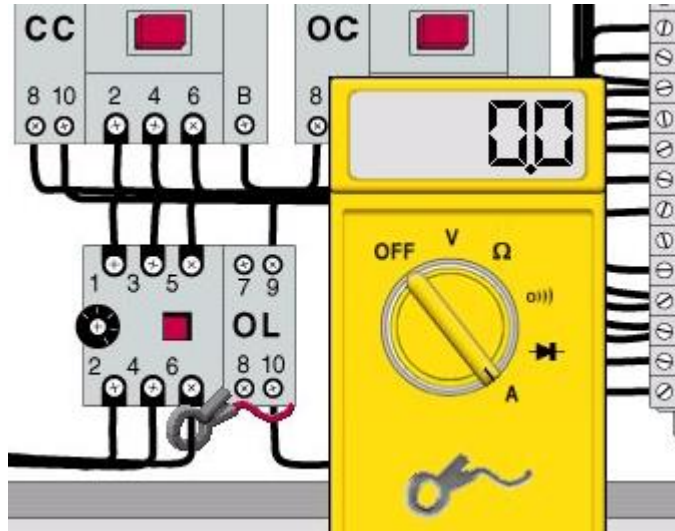

## Basic Methods of Fault Diagnosis Documentation

In this section we will look at three basic methods used for diagnostic documentation. These are:

- a) Symptom charts
- b) Algorithm charts
- c) Functional charts

## Structured Functional Block Diagrams

This form of diagnostic aid is based upon the use of block diagrams designed to describe the complete system or sub-system. Such diagrams show the logical interconnection and interaction between the various parts of the system. The various blocks on such diagrams represent identifiable functions and are called 'functional blocks'.

By definition, a function is an activity to modify something; it is intrinsically complete and contains all necessary services. It acts on the logic flow-path which maybe:

- Feedstock
- Control signals
- Service supplies

This approach often uses a nested hierarchy of block diagrams (as shown in the following diagram) together with a set of accompanying test data sheets. The top level diagram describes the overall system with the selection of functions represented on the diagram sufficient to permit the fault to be isolated to within a single major functional breakdown of each of the blocks on the following diagrams. This process is repeated until generally we are down to a particular printed circuit board, hydraulic valve etc. At this point the maintainer must be advised what to do.

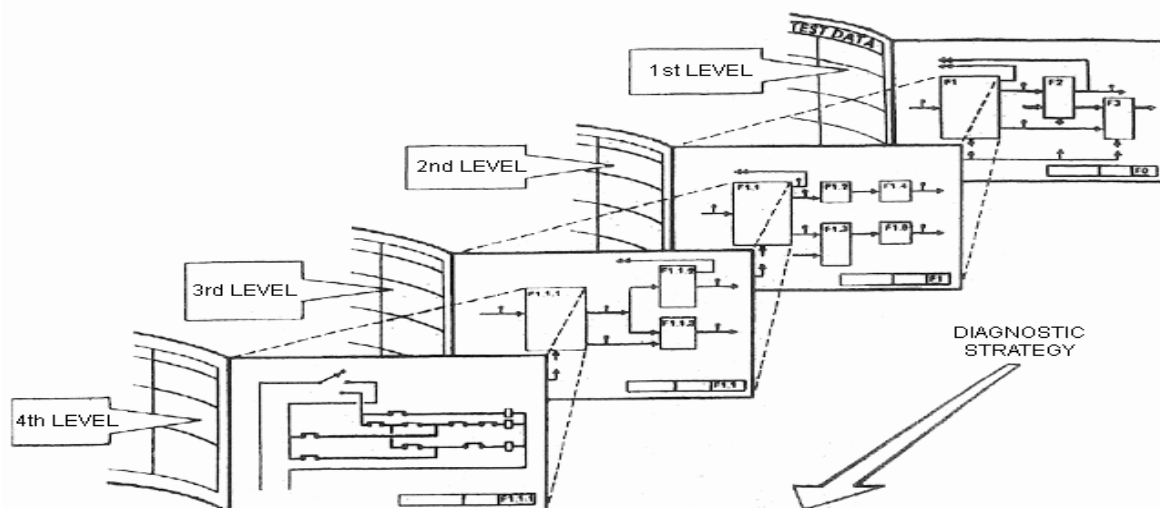

## Test Information

Each logic diagram must be accompanied by a test data chart. Also there must be sufficient test points on the equipment.

Information on the functional block should tell the maintainer what the function does and when it does it. It should not tell him how it works.

## Repair Policy

The repair policy associated with this technique is normally the replacement of faulty modules. The repair of modules is carried out in a workshop by more skilled labor or by the manufacturer. This requires suitable control and supervision of stockholding and repair turnaround of faulty modules

## Down Time and Repair Time

### (a) Realization Time

This is the time which elapses before the fault condition becomes apparent

### (b) Access Time

This involves the time, from realization that a fault exists, to make contact with displays and test points and so commence fault finding. This does not include the time to travel to the site, but the time required for removal of covers and shields and the connection of test equipment. This is determined largely by mechanical design

### (c) Diagnosis Time

This is referred to as fault finding and includes adjustment of test equipment (e.g. Setting up an oscilloscope or generator,) carrying out checks (e.g. Examining waveforms for comparison with a handbook), interpretation of information gained (this may be aided by algorithms), verifying the conclusions drawn and deciding upon the corrective action and in no specific sequence

### (d) Spare Part Procurement

Part procurement can be from the "tool-box", by cannibalization, or by taking a redundant identical assembly from some other part of the system. The time taken to move parts from a depot or store to the system is not included, being part of the logistic time

### (e) Replacement Time

This involves removal of the faulty LRA (Least Replaceable Assembly) Followed by connection and wiring, as appropriate, of a replacement. The LRA is the replaceable item beyond which fault diagnosis does not continue. Replacement time is largely dependent on the choice of LRA and on mechanical design features such as the choice of connectors and fittings

### (f) Checkout Time

This involves verifying that the fault condition no longer exists and that the system is operational. It may be possible to restore the system to operation before completing the checkout in which case, although a repair activity, it does not all constitute down time

### (g) Alignment Time

As a result of inserting a new module into the system, adjustments may be required. As in the case of checkout time, some or all of the alignment may fall outside the down time

### (h) Logistic Time

This is the time consumed waiting for spares, test gear, additional tools and manpower to be transported to the system

### (i) Administrative Time

This is a function of the system user's organization. Typical activities involve failure reporting (where this affects down time,) allocation of repair tasks, manpower changeover due to demarcation arrangements, official breaks, disputes, etc

Activities **(b) – (g)** are called **Active Repair Elements** and activities **(h)** and **(i)** **Passive Repair Elements**.

Realization time is not a repair activity but may be included in the MTTR<sup>1</sup> where down time is the consideration.

Checkout and alignment, although utilizing manpower, can fall outside the down time. The Active Repair Elements are determined by design, maintenance arrangements, environment, manpower, instructions, tools and test equipment.

Logistic and Administrative time is mainly determined by the maintenance environment, that is to say, the location of spares, equipment and manpower and the procedures for allocation tasks.

## Effecting Restoration

### Field or Workshop Repair

As a trouble-shooter, at some point or other, you will have to decide whether to send components to a workshop for repair as opposed to carrying out repairs on-site. Sometimes such a decision is simple, for example the work cannot be done on-site or special transport units may not be available in an acceptable time or the repair is essential for survival. At other times there may be a fine balance between choosing worksite or workshop repairs.

The following factors should be taken into account when making the decision on repair site:

- Availability of resources, that is, workshop, equipment and transport.
- Cost of workshop time.
- Transport costs of defective item versus repair equipment and staff.
- Time loss and production losses.
- Expertise availability.
- Availability of stores and parts.
- Coincidental advantage, for example, the machine was almost due for routine overhaul, or is generally debilitated and in need of other repairs.
- Requirement to set up clean areas, etc.
- Accessibility of worksite.

### Accommodation costs and availability.

Other considerations not specific to the job in hand are sometimes taken into account, for example, potential training advantages, cost-effectiveness audit, public relations or company prestige.

There is another factor that may preclude certain choices – availability of funds. This is particularly true of smaller companies whose overall maintenance reserves have become depleted.

One “game” which may be useful in forward planning is the “What if?” game. This game consists of a series of simple questions for which you must prepare answers.

“What if the diesel engines fail catastrophically? How would that fit into the list above?” “What if this item of repair equipment was purchased? How would that affect project repair capacity?” and so on.

The advantage of such an exercise is that you are in some ways prepared for many of the events that can plague an operation and can respond in an efficient manner. This is, or should be, a standard management planning routine for any operation. It should also be carried out by the on-site management staff or with their expertise available.

Assuming you have done your groundwork effectively, and have coasted a job with relative accuracy, then you should be in a position to evaluate the cost-effectiveness of worksite versus workshop repairs while taking into account all other advantages.

### Short term repair

Factors considered in deciding whether to affect a short term repair should include the following overrides:

- ***Safety must never be compromised.***
- ***No legal requirements should be violated.***
- ***System integrity should be maintained.***

If the above factors are met, then our choice as to whether to effect a short term repair becomes one of cost effectiveness. In evaluating this we may have to look at the cost of undoing the repair.

An example of a temporary repair might be the seal welding of flanges or other normally bolted items. The cost of replacement may exceed the advantages gained.

Overriding a running aid may result in an increase of workload for already pressed operators or an increase in staffing and may not be cost effective.

Some temporary repairs that remove aids can slow work rates to the extent that no advantage is gained. This is particularly true if a normally automatic process is forced into manual control.

In short, when deciding to carry out temporary repairs look not only at the immediate gains but also at the overall costs, risks and other disadvantages.

## **Repair or replace**

The decision to replace or repair an item must be made with a clear understanding of the relative values of each. The following points should be considered in a repair versus replacement decision:

- Whether replacement parts are available in a reasonable time frame and whether or not the part can be repaired in a reasonable manner and time.
- Whether the law allows or prohibits repair of a scheduled item by any other than the manufacturer or accredited person.
- Whether the repair can be guaranteed for a specific period.
- Repair will take less time than awaiting spares or vice-versa.
- The cost of replacement modules exceeds the gain from production in a fast changeover.
- The efficacy of the repair, that is, how long it may be expected to hold and its effect on efficiency of operation, particularly with makeshift-repairs and substitution of components.
- The loss of warranty.
- The general condition of the component, that is, is the system likely to fail in other places as a result of the repair. This is a part of the old adage “new wine in old wineskins”. If a unit or assembly is in a generally poor condition through age or misuse, the fitting of a new component or sub-assembly can increase strain on other parts.

In a like manner, consideration must be given to the effect of mixing new components with old, particularly if the new component has been upgraded.

Careful consideration should also be given to whether the failure of a component indicates the likely failure of similar components. Metal fatigue failure in one part of a casting, for example, may indicate the unsuitability of the whole casting.

The answer to the question posed depends on a number of local factors and can only be made on the spot for a given module, unit or item in a system.

## ***Fault Condition Reporting***

While repairs are under way it is sometimes necessary to hand over the work or the equipment to someone else. If this is to work efficiently you must be able to pass on all relevant information. This is also important to ensure the safety of all personnel while the system is not in its usual operating condition.

The steps involved are:

1. Document all changes to normal operational line-up either in the log or, if the system is in use, on forms supplied for this purpose. You should also make notes in your personal journal.
2. Set out work schedules in accordance with safe practices and nominated company procedures. This may require you to document all notifications given to relevant persons together with Authority to Carry Out Running Repairs, Work Permits, Clearance Certificates, Tags (Danger and Out of Service, etc.) Locks and Sentinels in operation or other applicable special precautions.
3. Highlight any special precautions or fallback procedures relating to operation of running equipment.
4. Prepare a concise report on the current status of the repair being undertaken including personnel involved, equipment or tooling obtained, equipment or tooling ordered or required, parts availability, strip-down status of the machine and estimated completion time.



5. Pass on findings in regard to component condition or potential weaknesses found during dismantling and other information necessary for the person taking over to make informed decisions.
6. Where practical, carry out a tour of inspection with the new person of the affected plant, pointing out areas of concern and activities under way.
7. Ensure they have understood you and have a clear picture of the situation and its implications.

## MAINTENANCE

In general, Maintenance means to hold, keep, sustain or preserve the building or structure to an acceptable standard. Acceptable standard is defined as one which sustains the Utility and value of the facility. The question of what is an acceptable standard? Is a matter of conjecture and is generally subjective. Each owner or tenant will have to establish his own standards based on many factors, such as:

- Usage of building
- Anticipated life
- Availability of capital, materials and manpower
- Change in Usage and personal
- Business prestige.

### Reasons for Maintenance

Maintenance serves to protect the owners' real estate investment in a number of ways.

- **Physical Integrity.** To keep the assets in good working order so as to minimize disruptions and downtimes.
- **Risk Management.** To keep the assets in a state of good repair for the owners' health and safety.
- **Aesthetic Preservation.** To keep the assets from deteriorating in appearance and becoming unsightly.
- **Responsible Stewardship.** To ensure that the assets achieve their full potential service life.
- **Fiscal Responsibility.** To leverage efficiencies that can be reflected on the owners' balance sheet.
- **Duty of Care.** To satisfy a legislated duty that is owed to owners, occupants and guest on the property.
- **Duty to Mitigate.** To prevent unnecessary damage to assets that may result in their premature failure

### Principle Objectives in Maintenance

- To achieve product quality and customer satisfaction through adjusted and serviced equipment
- Maximize useful life of equipment
- Keep equipment safe and prevent safety hazards
- Minimize frequency and severity of interruptions
- Maximize production capacity – through high utilization of facility

### Problems in Maintenance

- Lack of management attention to maintenance
- Little participation by accounting in analyzing and reporting costs
- Difficulties in applying quantitative analysis
- Difficulties in obtaining time and cost estimates for maintenance works
- Difficulties in measuring performance

### Problems Exist Due To:

- Failure to develop written objectives and policy
- Inadequate budgetary control
- Inadequate control procedures for work order, service requests etc.

- Infrequent use of standards
- To control maintenance work
- Absence of cost reports to aid maintenance planning and control system

### Maintenance Objectives

- Must be consistent with the goals of production (cost, quality, delivery, safety)
- Must be comprehensive and include specific responsibilities

### Maintenance Costs

- Cost to replace or repair
- Losses of output
- Delayed shipment
- Scrap and rework

### Three Types of Maintenance

In the maintenance literature it is generally recognized that maintenance philosophies can be grouped into three broad categories

No		Description	Example
1	<b>Corrective maintenance(CM)</b>	Maintenance tasks are intentionally withheld until an asset stops working or starts failing. Maintenance is then performed as necessitated.	Lubricate motors when they Become noisy or vibrations occur.
2	<b>Preventative Maintenance (PM)</b>	Maintenance tasks are performed at regular intervals, based on industry Expected equipment life spans and failure patterns.	Lubricate pumps every 2,000 hours
3	<b>Predictive Maintenance (PdM)</b>	Maintenance is conducted only when it is confirmed necessary through the use of non-destructive tests that detect potential failure conditions before their occurrence.	Conduct scans on pumps and panels to determine if and when work is required.

## 1. Preventive Maintenance

Preventive maintenance can be defined as follows: Actions performed on a time- or machine-run-based schedule that detect, preclude, or mitigate degradation of a component or system with the aim of Sustaining or extending its useful life through controlling degradation to an acceptable level.

### Advantages

- Cost effective in many capital-intensive processes.
- Flexibility allows for the adjustment of maintenance periodicity.
- Increased component life cycle.
- Energy savings.
- Reduced equipment or process failure.
- Estimated 12% to 18% cost savings over reactive maintenance program.

### Disadvantages

- Catastrophic failures still likely to occur.
- Labor intensive.
- Includes performance of unneeded maintenance.
- Potential for incidental damage to components in conducting unneeded Maintenance.

## 2. Predictive Maintenance

Measurements that detect the Onset of system degradation (lower functional state), thereby allowing causal stressors to be Eliminated or controlled prior to any significant deterioration in the component physical state. Results indicate current and future functional capability.

Basically, predictive maintenance differs from preventive maintenance by basing maintenance need on the actual condition of the machine rather than on some preset schedule. You will recall that preventive maintenance is time-based. Activities such as changing lubricant are based on time, like calendar time or equipment run time. For example, most people change the oil in their vehicles every 3,000 to 5,000 miles traveled. This is effectively basing the oil change needs on equipment run time.

### Advantages

- Increased component operational life/availability.
- Allows for preemptive corrective actions.
- Decrease in equipment or process downtime.
- Decrease in costs for parts and labor.
- Better product quality.
- Improved worker and environmental safety.
- Improved worker morale.
- Energy savings.
- Estimated 8% to 12% cost savings over preventive maintenance program.

### Disadvantages

- Increased investment in diagnostic equipment.
- Increased investment in staff training.
- Savings potential not readily seen by management

## 3. Corrective maintenance

Corrective or Breakdown maintenance implies that repairs are made after the equipment is failed and cannot perform its normal function anymore .It is basically the “run it till it breaks” maintenance mode. No actions or efforts are taken to maintain the equipment as the designer originally intended to ensure design life is reached No routine maintenance tasks are performed and the only “planned” maintenance on the asset is corrective maintenance after a problem necessitates some action. **In order for a Corrective Maintenance (CM) strategy to be considered prudent (in some limited circumstances), assets must meet one or more of the following criteria:**

- Assets that is not maintainable.
- Assets that is disposable and cheaper to replace than to fix.
- Small assets without significant financial value.
- Assets whose downtime is non-critical.
- Assets that are not subject to wear and tear.
- Assets that is unlikely to fail during the life of the building.
- Assets that is prone to technological obsolescence.

Corrective maintenance has a legitimate role to play in the overall maintenance program, albeit a limited one. The advantages of corrective maintenance can be viewed as a double-edged sword and therefore skill and care is required when determining which assets should be allowed to run to failure.

### Advantages

- **Lower short-term costs**
- **Requires less staff since less work is being done**

### Disadvantages

- Increased long-term costs due to unplanned equipment downtime Possible secondary equipment or process damage
- Breakdown generally occurs inappropriate times leading to poor and hurried maintenance
- Excessive delay in production & reduces output
- Faster plant deterioration

- Increases chances of accidents and less safety for both workers and machines
- More spoilt materials
- Direct loss of profit
- Cannot be employed for equipment's regulated by statutory provisions e.g. cranes, lift and hoists etc.

The figure below provides a correlation between the maintenance costs and repair costs associated with the three different maintenance strategies. While Predictive Maintenance (PDM) generally has the highest maintenance cost, it will result in the lowest repair costs. CM, on the other hand, has the lowest maintenance cost but the highest corresponding costs associated with asset repairs.

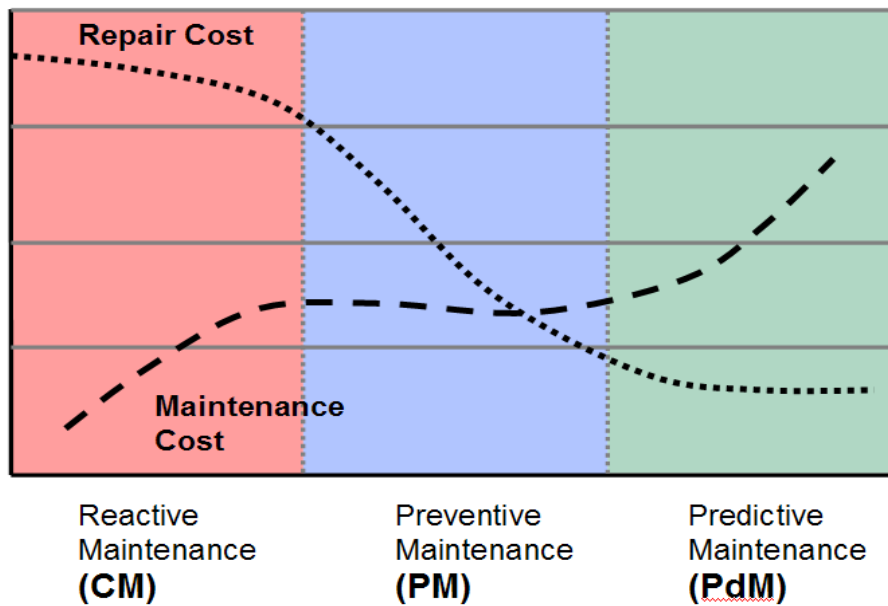

The Purpose of specific maintenance activities is to better serve production by:

- Improving equipment availability.
- Faster response.
- Higher focus of knowledge on machinery.
- Better visibility.
- Enhanced relations with production.
- And increased enablers for continuous improvement.

### Expectations of Maintenance person

- Safe work practices.
- Improve Professional conduct
- Repair and improve equipment
- Clean and tidy workplace
- First response to problem issues in their area
- Call for assistance when needed
- Make routine calls at least once a day to all of the areas assigned
- Obtain control and update documentation for area equipment that includes:
  1. Drawings
  2. Procedures
  3. Manuals

### Work Orders

- Breakdown.

- Urgent repair.
- Originated from preventive maintenance inspection,
- Normal repair.
- Modification /continuous improvement.

### **Breakdown work requests**

- Maintenance person communicated verbally via two-way radio.
- The operator will fill out the top three lines of the Maintenance Breakdown Service Log Sheet located in the Maintenance Breakdown Service Log Book.
- The maintenance person will fill out the dark areas after the job is completed or when the job was stopped.
- Put the serves request in history file for a particular piece of equipment.

### **Equipment Inspections**

- Equipment inspections will be performed by both the operators and maintenance.
- Inspections can and will happen: **daily, weekly, monthly, quarterly, semiannually, and annually.**
- Developing and training operators in the proper techniques for machine inspection.
- The weekly/monthly/quarterly lubrication and preventive maintenance schedules are necessary to assure machine reliability, and safety .
- Master copy of each inspection will be located in the Maintenance Supervisor's Equipment Files.

### **Document Control**

The Document control falls under three categories:

- retaining
- updating
- and deleting document
- Retaining documents means to collect all useful information of the specific items and store them in a logical manner.
- Information includes drawings, operator's manuals, maintenance /service manuals, and equipment inspection documents.

### ***Success Measurable***

**The measurable will include:**

- Equipment downtime.
- Work order backlog.
- Response time.
- Span of time equipment was down per breakdown.
- PM Achievement Rats.
- Total work orders performed.