

CData Software, Inc.

---

# **DBAmp**

*SQL Server Integration with Salesforce.com*

Version 5.1.6

# Table of Contents

---

<b>Acknowledgments</b> .....	<b>7</b>
<b>Chapter 1: Installation/Upgrading</b> .....	<b>8</b>
Upgrading an existing installation.....	8
Prerequisites .....	9
Running the DBAmp installation file.....	9
Configure the DBAmp provider options.....	9
Connecting DBAmp to SQL Server .....	10
Verifying the linked server .....	11
Install the DBAmp Stored Procedures .....	11
Running the DBAmp Configuration Program.....	11
Setting up the DBAmp Work Directory.....	12
Enabling xp_cmdshell for DBAmp.....	13
Pointing DBAmp to your Salesforce Sandbox Instance .....	13
<b>Chapter 2: Using DBAMP as a Linked Server</b> .....	<b>14</b>
Four Part Object Names .....	14
SQL versus SOQL.....	14
Using the four part object name and SQL .....	14
Using OPENQUERY and SOQL.....	15
Inserting rows using SQL.....	17
Updating and Deleting rows using SQL .....	18
Joining Salesforce.com Tables.....	19
Analyzing Performance when Joining Tables .....	19
Using BIT datatype with DBAmp .....	21
Using Dates with DBAmp.....	21
Using DBAmp System Tables (sys_sf tables).....	22
Using DBAmp System Views .....	23
Using Count() with salesforce.com objects.....	25
Using DBAmp to convert currency amounts to a default currency.....	25
Using DBAmp to return translated values for picklists .....	26
Retrieving Archived and Deleted records .....	26
Using Column Subset views .....	26
DBAmp and Salesforce API call Counts .....	27
Big Objects Support .....	28

Platform Events Support.....	30
<b>Chapter 3: Making Local Copies of Salesforce Data .....</b>	<b>31</b>
How SF_Mirror works .....	31
How to run the SF_Mirror proc to make a local copy .....	32
Viewing the job history .....	33
Mirroring all Salesforce Objects .....	33
How to run the SF_MirrorAll proc to replicate all objects .....	33
Copying only the rows that have changed .....	34
Including Archived and Deleted rows in the local copy.....	34
How to run the SF_Mirror proc without using xp_cmdshell.....	34
Best Practices Incorporated into SF_Mirror .....	35
Using the DBAmpTableOptions Table .....	35
Making Local Copies with a Subset of Columns .....	37
Making Local Copies as Temporal Tables .....	38
<b>Chapter 4: Bulk Insert, Upsert, Delete and Update into Salesforce using SF_TableLoader.....</b>	<b>41</b>
Differences between SF_BulkOps and SF_TableLoader .....	41
Why SF_TableLoader over SF_BulkOps? .....	41
Checking the Column Names of the Input Table.....	42
Using External Ids as Foreign Keys.....	43
Understanding the Error Column .....	43
Bulk Inserting rows into Salesforce.....	44
Bulk Upserting rows into Salesforce.....	44
Bulk Updating rows into Salesforce .....	44
Bulk Deleting rows from Salesforce .....	45
Bulk HardDeleting rows from Salesforce .....	45
Bulk UnDeleting rows from Salesforce .....	45
Controlling the batch size with SF_TableLoader.....	45
Understanding a Sort Column when using SF_TableLoader .....	46
How to run the SF_TableLoader proc .....	46
How to run the SF_TableLoader proc without using xp_cmdshell .....	47
SF_TableLoader Sample Recipe .....	49
Understanding SF_TableLoader failures.....	50
Using Optional SOAP Headers.....	50
Converting Leads with SF_TableLoader .....	51

Using IgnoreFailures Option with SF_TableLoader .....	53
Using AssignmentRuleId Option with SF_TableLoader .....	53
<b>Chapter 5: Using SSIS with DBAmp .....</b>	<b>55</b>
Using the linked server as an SSIS Source .....	55
Pushing Data to Salesforce.com using SSIS .....	55
<b>Chapter 6: Uploading files into Content, Documents and Attachments .....</b>	<b>57</b>
<b>Chapter 7: DBAmp Stored Procedure Reference .....</b>	<b>62</b>
SF_BulkOps .....	62
SF_TableLoader .....	67
SF_BulkSOQL.....	75
SF_BulkSOQL_Refresh.....	80
SF_CreateKeys.....	82
SF_DownloadBlobs.....	83
SF_DropKeys .....	85
SF_Generate.....	86
SF_Mirror .....	87
SF_MirrorAll .....	92
SF_Refresh .....	94
SF_RefreshIAD .....	96
SF_RefreshAll .....	98
SF_Replicate .....	100
SF_ReplicateAll .....	102
SF_ReplicateIAD .....	104
SF_MigrateBuilder .....	106
SF_MigrateGraphML .....	109
<b>Chapter 8: Using the DBAmp Configuration Program.....</b>	<b>111</b>
Options Page of the DBAmp Configuration Program .....	111
Registry Settings Page of the DBAmp Configuration Program .....	113
<b>Chapter 9: Retrieving Salesforce Metadata .....</b>	<b>118</b>
How to run the SF_Metadata proc.....	118
Using the LIST and RETRIEVE operations .....	118
Requirements for the input table.....	119
Example: Retrieve Dependent Picklist Information .....	121
Example: Retrieve Field Descriptions .....	122
<b>Chapter 10: Using DBAmp Performance Package.....</b>	<b>124</b>

Installing the DBAmp Performance Package.....	124
Using the DBAmp_Log Table.....	126
Using the Performance Views.....	127
DBAmp_Replicate_Perf view .....	127
DBAmp_Refresh_Perf view .....	128
DBAmp_TableLoader_Perf view .....	129
Enabling the Performance Trace .....	130
<b>Chapter 11: MigrateAmp .....</b>	<b>131</b>
What is MigrateAmp? .....	131
Installing MigrateAmp .....	131
MigrateAmp Approaches.....	132
Understanding MigrateAmp Concepts .....	132
MigrateAmp Workflow .....	136
MigrateAmp Architecture .....	137
<b>Chapter 12: Using MigrateAmp .....</b>	<b>140</b>
Using the SF_MigrateBuilder Stored Procedures .....	140
Running SF_MigrateBuilder in User Interface .....	141
Running SF_MigrateBuilder in SQL Management Studio .....	144
Replicating the Source org data .....	146
Loading the Target org data .....	146
Resetting the Target org data if needed .....	146
An in-depth look at the SF_MigrateBuilder Parameters .....	147
Passing Parameters to _Load Stored Procedure .....	150
Migrating Salesforce CRM Content.....	150
Migrating Salesforce Knowledge.....	151
Migrating Single Salesforce Knowledge Article Type .....	152
Migrating Multiple Salesforce Knowledge Article Types .....	153
Associating Knowledge Articles with Cases.....	154
Frequently Asked Questions.....	154
<b>Chapter 13: Viewing a Migration Database Diagram.....</b>	<b>156</b>
<b>Chapter 14: DBAmp Client .....</b>	<b>162</b>
Why DBAmp Client? .....	162
Installing DBAmp Client.....	163
Running the DBAmp Client .....	164
Performing a Mirror Action.....	165

Performing a TableLoader Action .....	166
Performing a DownloadBlobs Action .....	167
Previewing Output .....	167

## Acknowledgments

Thanks to Sarah Parra of Microsoft. Without her excellent support, DBAmp wouldn't exist.

Also, thanks to Dave Carroll at Salesforce.com for being the "Original" sForce programmer. Dave's sample code always points the way for the rest of us.

And finally, thanks to those customers who have contributed ideas and designs for several important features of DBAmp:

C.J. Land	Local copy replication
Andy Hilliard	Sys_sfPickList
Darrell Grissen	Sys_sfLastId
Tad Tjornhom	Bulk Inserting
Paul Coyne	sf_replicateIAD
John Gee	Metadata support

# Chapter 1: Installation/Upgrading

## **Upgrading an existing installation**

### **BREAKING CHANGES WITH v5.0.1 OR GREATER:**

- **DBAmp now uses bit datatype instead of varchar(5) for all boolean fields.**
- **All fields are now nullable, except for Id field on local tables.**

**Please make sure all downstream processes that use the local tables are compatible with the above changes.**

If you are upgrading an existing installation, please do the following.

1. Stop SQL Server.
2. Run the DBAmp installation program. You will need your serial number for installation. Please contact [dbampsupport@cdata.com](mailto:dbampsupport@cdata.com) if you need help with this value.
3. Your previous linked server definition can be use without modification.
4. The DBAmp stored procedures change with every release. You must upgrade every SQL database that currently contains DBAmp stored procs with the new versions. Follow the instructions in the **Install the DBAmp Stored Procedures** section later in this chapter. Failure to do this will result in errors.
5. Because the new version may connect to a newer API endpoint, additional fields and objects may become visible with the upgrade. If you are using sf\_refresh for local copies, you must run sf\_replicate on that object to pickup these schema changes. Then you can resume your normal sf\_refresh schedule.

Note that there are major, breaking changes that have occurred recently with DBAmp.

- **DBAmp only supports SQL 2008 or higher.**
- **DBAmp only supports Windows 2008 R2 or higher.**
- **DBAmp only support 64 bit Windows OS.**
- **DBAmp requires the .NET 4.6 library or higher**
- **SQL 2008 or greater and datetime2(7).** On SQL 2008 or greater systems, date and datetime fields of salesforce.com objects are now created as datetime2(7) fields in the local database. To force these fields to be created as datetime fields instead, set the Database Compatibility



Level of the Salesforce backup database to 90 prior to replicating the data (step 5 above). This change applies to SQL 2008 and greater only.

### **Prerequisites**

Before installing DBAmp, make sure that an instance of SQL Server 2008 or greater is installed on the machine. If you do not have SQL Server, you may download the SQL Server 2008 Express with Database Tools, which is available for free from Microsoft. In addition, be aware that DBAmp only supports Windows 2008 R2 or higher.

**IMPORTANT: If you are using SQL Server Express, make sure you download the package from Microsoft that contains the Database Tools. You will need the SQL Management Studio tool to complete the DBAmp installation.**

There is an outstanding Microsoft issue that affects DBAmp. This issue only occurs when the service account that you specify for SQL Server is the **Network Service** account. Please use a different service account (like a user account) for the SQL Server instance. We recommend that you use the LocalSystem account or an admin domain.

### **Running the DBAmp installation file**

To install DBAmp, unzip the DBAmp package to a temporary directory and run the DBAmpInstall.exe program. DBAmpInstall.exe will prompt you for the DBAmp program directory and install the software.

To uninstall DBAmp, use the Windows Add/Remove Programs option on the control panel.

### **Configure the DBAmp provider options**

**NOTE: DO NOT SKIP THIS STEP. DBAMP WILL NOT FUNCTION PROPERLY.**

Expand the Providers tree entry in the Object Explorer (Server Objects/Linked Servers/Providers). Right click the DBAmp.DBAmp provider entry and choose **Properties**.

Check **only** the following options:

**Dynamic Parameters**

**Allow InProcess**

**Non transacted Updates**

Verify the above options for proper operation of the provider.

The next step is to create the linked server.

## Connecting DBAmp to SQL Server

Also, please see the note at the beginning of the chapter concerning the Microsoft issue of using **Network Service** as the SQL Server Service account.

DBAmp is designed to be used as a linked server. To install DBAmp as a linked server, use the SQL Management Studio and perform the following steps:

1. Using the SQL Server Management Studio, use the Object Explorer window and expand the **Server Objects** branch to display **Linked Servers**.
2. Right click on **Linked Servers** and choose **New Linked Server...**

Enter the following information for the new Linked Server:

### General Page

**Linked Server:** Enter **SALESFORCE**. **Note:** We recommend not having any spaces or hyphens in the linked server. If you need spaces or hyphens in the linked server name, make sure to put brackets around the linked server name in all DBAmp commands.

**Provider:** Choose **DBAmp OLE DB Provider**

**Product Name:** Enter **DBAmp**

**Source:** Enter **SALESFORCE**

**Location:** If you are connecting to a sandbox, enter <https://test.salesforce.com>. Otherwise, **leave blank**.

### Security Page

Click **Be made using this security context:**

For **Remote Login:**, enter your salesforce.com UserId.

For **With password:** enter your salesforce password. If needed by your salesforce organization, append the salesforce security token to the end of the password. For more details on salesforce security tokens, see the Security Tokens section in the online salesforce help.

### Server Options

Check the following are **true** (leaving all other options **false**):

- **Collation Compatible**
- **Data Access**

- **Use Remote Collation**
- **RPC Out**
- **Enable Promotion of Distributed Transactions**

3. Press **OK** to create the SALESFORCE linked server.

#### **Verifying the linked server**

Use the following procedure to verify that the linked server is set up correctly:

Execute the following query using the SQL Management Studio:

Select \* from SALESFORCE...sys\_sfobjects

You should see a list of all your salesforce.com objects.

#### **Install the DBAmp Stored Procedures**

The next step to install DBAmp is to create a database and create the DBAmp stored procedures. The database you create contains not only the DBAmp stored procedures but also the local replicated tables you make from your live Salesforce.com data.

To install the DBAmp Stored Procedures:

1. 1. Using either the SQL Enterprise Manager or the SQL Management Studio, create a new database named **salesforce backups**. This database will hold all the local replicated tables as well as the DBAmp stored procedures.
2. Open the file "**Create DBAmp SPROCS.sql**" in Query Analyzer or Management Studio but do not execute it yet. The file is located in the \Program Files\DBAmp\SQL directory.

The stored procedures assume that you have installed DBAmp in the directory c:\Program Files\DBAmp. If you used an alternate drive or directory, you must find all occurrences of C:\Program Files\DBAmp\ and replace them with the correct directory.

3. Make sure that default database shown on the toolbar is the **salesforce backups** database (and not the **main** database). Then, execute (F5) to add the stored procedures to the database.

#### **Running the DBAmp Configuration Program**

In order for the DBAmp stored procedures to work properly, you must run the DBAmp configuration program and enter your SQL credentials along with any additional proxy information needed by DBAmp.

**You must display the Options dialog and press OK for the settings to be saved (press OK even if you do not make changes).**

**Note:** Normally, DBAmp handles the proxy automatically. If you are having trouble connecting or need to setup your proxy information manually, you can use the DBAmp Configuration Program to enter your proxy information.

To run the DBAmp Configuration Program:

1. From the Start menu, run the **DBAmp Configuration** program located under DBAmp. Under the **Configuration** menu, **select Options**.
2. Choose a DBAmp Work Directory. The DBAmp Work Directory holds the work files produced by the Replicate Stored Procedures when using the **BulkApi or PKChunk options**. Use the Browse button to create, find and set the work directory. Make sure the directory is on a drive with enough space. Large downloads will expand the size of this directory dramatically.
3. Enter your SQL credentials. If you are using Windows Authentication, use the default value of **Trusted\_Connection=Yes**
4. If you need to enter proxy information, check the **Use Proxy for Salesforce connection** checkbox.
5. Enter the appropriate proxy information:
  - Proxy Username** - Username for the proxy login.
  - Proxy Password** - Password for the above username.
  - Proxy URL** - Direct proxy URL.
  - Proxy ConfigURL** - Proxy script URL.

When a script URL is set but the proxy address cannot be accessed, for example, the address is only available inside a corporate network but the user is logging in from home, DBAmp will use the direct URL if it has been set, or try a direct connection if the direct URL has not been set.

If a direct URL is set and it cannot be accessed, DBAmp will not try a direct connection. This is the same behavior as Internet Explorer.

**Click OK. The credentials are stored in encrypted form for use by the DBAmp stored procedures.**

### **Setting up the DBAmp Work Directory**

The DBAmp Work Directory holds the work files produced by the Replicate stored procedures when using the **BulkApi or PKChunk options**. The

Work Directory must be setup before running the Replicate stored procedures when using the BulkAPI or PKChunk options.

To setup the DBAmp Work Directory follow the instructions below:

1. Run the DBAmp Configuration Program on the server DBAmp is installed on.
2. Navigate to the Configuration/Options page
3. Use the DBAmp Work Directory Browse button to create a Work Directory on the server
4. Click OK

**Notes:**

- **Make sure the directory is on a drive with enough space. Large downloads will expand the size of this directory dramatically.**
- **- The SQL Server instance must be able to read and write to this directory.**
- **DO NOT use the C: for the Work Directory. Otherwise, the Work Directory could expand to take all the space on the C: drive and impair the Windows Operating System.**

**Enabling xp\_cmdshell for DBAmp**

The DBAmp stored procedure use the xp\_cmdshell command. If you are not an SQL Server administrator, you must have the proper permission to use this command. See the SQL Server documentation under the topic xp\_cmdshell for more information. To quickly test, run the following sql in Query Analyzer:

**Exec master..xp\_cmdshell "dir"**

**Pointing DBAmp to your Salesforce Sandbox Instance**

By default, DBAmp points to your production Salesforce.com instance. If you need to change DBAmp to point to your Sandbox instance or need to use a different endpoint for DBAmp, alter the Location parameter of your linked server.

The Location parameter is normally blank. If your Sandbox Instance is at <https://test.salesforce.com> then you would enter <https://test.salesforce.com> for the Location Parameter on the linked server properties page.

## Chapter 2: Using DBAMP as a Linked Server

When using DBAmp as a linked server, you can access salesforce.com tables as if they were SQL server tables.

### **Four Part Object Names**

To refer to a salesforce.com object in a SQL statement, use the four part object name containing the name of the linked server and the object name separated by three periods. For example, to select all rows and columns of the Contact object:

**Select \* from SALESFORCE...Contact**

The linked server name (SALESFORCE) and the table name (Contact) are case sensitive.

### **SQL versus SOQL**

There are 2 ways to query real time data from salesforce: use the four part object name with SQL or use the OpenQuery clause with SOQL.

### **Using the four part object name and SQL**

You may use the full Transact SQL syntax when entering SQL statements. Internally, SQL Server and DBAmp will translate your SQL statement into the appropriate SOQL statements for salesforce.com. Any elements that cannot be done in SOQL (like SQL functions) will be done locally by the SQL Server Distributed Query optimizer after retrieving the result set from salesforce.com.

The SQL Server Distributed Query Optimizer will choose a plan for every SQL statement that executes. Often, the plan chosen will be the most efficient and there will be no need to modify your SQL.

Should you suspect a poorly performing plan, use the Query Analyzer and enter the text of the SQL statement. Remember to use the 4 part naming convention for the Salesforce.com tables, i.e. SALESFORCE...Account.

For maximum performance when joining, consider using the OpenQuery clause with SOQL (described in the next section).

Note the following when using SQL:

- Do not enter unquoted date literals. Instead, use Transact SQL syntax for date literals (i.e. include quotes)
- For SOQL Boolean fields, use quoted literals ( 'false' instead of false).
- You may use \* to indicate all columns.

- Following Transact SQL rules for where clause AND/OR precedence. Parentheses are only needed when explicit grouping is needed and are not required (unlike SOQL).
- User and Case are keywords in Transact SQL and must be quoted when used as a four part name to refer to the salesforce.com object. For example, specify the User Object as SALESFORCE...[User]

### Using OPENQUERY and SOQL

When additional join performance is needed, consider using the OPENQUERY clause with DBAmp. Using OPENQUERY allows you to pass salesforce.com SOQL statements (not SQL) directly to DBAmp. A full description of the SOQL language can be found on the salesforce.com website at :

[http://www.salesforce.com/us/developer/docs/api/index\\_Left.htm#StartTopic=Content/sforce\\_api\\_calls\\_soql.htm](http://www.salesforce.com/us/developer/docs/api/index_Left.htm#StartTopic=Content/sforce_api_calls_soql.htm)

Using OPENQUERY with SOQL can make dramatic performance differences on data that is joined. With SOQL, the join is performed back at the salesforce.com server as opposed to locally at the SQL server.

```
select * from openquery(salesforce,
'SELECT Type, BillingCountry,
      GROUPING(Type) grpType, GROUPING(BillingCountry) grpCty,
      COUNT(id) accts
FROM Account
GROUP BY CUBE(Type, BillingCountry)
ORDER BY GROUPING(Type), GROUPING(BillingCountry)')
```

**- DBAmp currently supports both child to parent relationship queries and Parent to child queries.**

For example,

```
select * from openquery(salesforce,
'SELECT Account.Name, (SELECT OwnerId FROM Account.Notes) FROM
Account')
```

```
select * from openquery(salesforce,
'SELECT Id, Who.FirstName, Who.LastName FROM Task');
```

**- The where clause of the SOQL statement must be expressed using SOQL syntax, not SQL syntax.**

For example,

```
Select * from OpenQuery(SALESFORCE,  
'Select Opportunity.Account.Name,  
Opportunity.Account.AnnualRevenue, Opportunity.Name,  
Opportunity.CloseDate, Opportunity.StageName, Description,  
Quantity  
From OpportunityLineItem  
Where (Opportunity.Account.AnnualRevenue >200 AND  
Opportunity.CloseDate < 2009-08-29)')
```

is a supported SOQL statement because the date value is not in quotes.

```
Select * from OpenQuery(SALESFORCE, 'SELECT Id FROM Account  
WHERE Owner.CreatedDate = LAST_N_DAYS:200')
```

is also supported because it uses a SOQL date literal.

Note that datetime constants must be entered in ISO8601 format per the SOQL requirements.

### **Understanding hierarchical salesforce.com data when using OPENQUERY and SOQL**

Note: The following is **only** applicable when using SOQL and OPENQUERY. When joining the linked server tables using standard SQL, the result table is constructed using normal relational concepts and not as describe here.

For OPENQUERY SOQL, DBAmp uses a special algorithm to "flatten" parent-child salesforce.com data into a two-dimensional table.

SQL Server results are two-dimensional with rows and columns. Because salesforce.com data can have more than two dimensions, a flattening algorithm is used to force the data into a two-dimensional format.

When flattening salesforce.com data in SQL Server, the column headings are an indication of the source of the column and essentially contain the navigation through the "tree" of returned data to get to that column. You can read the column structure backwards to get to the root object, the lookup objects, and related lists. For example, the column Account\_LastModifiedBy\_Alias is the Alias field of the LastModifiedBy lookup object for the Account root object.

There is a row of the root object for each object in a related list. When there are two related lists, the root object in the flattened result gets repeated by the sum of the count of all of the rows of the related lists. For example, if an Account root object has five Contacts and eight Cases, the root-object data is repeated in the result table thirteen times.



In the flattened result, fields of the Contact related list are shown with the root object, along with fields of the Cases related list and the root object. For rows where Contact data is returned, the Cases columns are null; for rows where Cases data is returned, the Contact columns are null. The fields are null because there really is no relationship between Contacts and Cases.

When the query contains a root object and multiple related lists, DBAmp repeats the root-object data, the sum of the count of all of the related lists. For example, if five related lists each had five items in them, the root object is repeated 25 times. Rows for related lists are displayed and the values in each row for the other related lists are null because they are not applicable.

## **Passing Parameters in SOQL queries**

To use parameters in a SOQL query, you must use the EXECUTE statement of T-SQL. Here is an example:

```
CREATE TABLE RevByAccount
( Name      nvarchar(255) NULL,
  AnnualRevenue  decimal(18,0) NULL
);

DECLARE @MinRev INT
SET @MinRev = 20

INSERT RevByAccount
EXEC ( 'SELECT Name, AnnualRevenue FROM Account WHERE
AnnualRevenue > ?',
      @MinRev) AT Salesforce

go
```

## **Inserting rows using SQL**

To insert new rows, use the standard SQL Insert statement. Do not include the read-only columns (i.e. Id, LastModifiedId, etc.) in the fields list. For example, to insert a new Note use the following SQL:

```
INSERT INTO SALESFORCE...Note (Body, IsPrivate, ParentId, Title)
VALUES('Body of Note 2','false', '00130000005ZsG8AAK','ToDelete')
```

For maximum scalability, please consider using the **sf\_TableLoader** stored procedure instead of SQL Insert statement. The **sf\_TableLoafer** stored

procedure takes advantage of the ability to batch together insert requests to the salesforce.com api.

### **Updating and Deleting rows using SQL**

DBAmp supports updating and deleting Salesforce.com objects with SQL. In order to get the maximum performance with your UPDATE and DELETE statements, you need to understand how SQL Server handles UPDATE/DELETE statements with a linked server (like DBAmp).

For example, take the following SQL UPDATE

#### **Update SALESFORCE...Account**

**Set AnnualRevenue = 4000**

**Where Id='00130000005ZsG8AAK'**

Using the **Display Estimated Execution Plan** option from the **Query Analyzer**, you can see that SQL Server will retrieve the entire Account table from Salesforce and then search for the one row that has the Id of 00130000005ZsG8AAK. Then, SQL Server will update the AnnualRevenue of that row.

Obviously, this UPDATE statement has poor performance which gets worse as the size of the Account table grows. What we need is a way to retrieve only the row with Id 00130000005ZsG8AAK and then update the AnnualRevenue of that row. To do this, use an OPENQUERY clause as the table name.

#### **Update OPENQUERY(SALESFORCE,**

**'Select Id, AnnualRevenue from Account**

**where Id="00130000005ZsG8AAK" ')**

**set AnnualRevenue = 4000**

Using an OPENQUERY clause insures that we retrieve only the row with the proper Id.

You can construct stored procedures that make your code more readable and that use the above technique. See the **Create SF\_UpdateAccount.sql** file in the DBAmp program directory as an example. Using this stored procedure, we can do updates to the Account table using the following SQL:

```
exec SF_UpdateAccount '00130000008hz55AAA','BillingCity','"Denver"'
```

or

```
exec SF_UpdateAccount '00130000008hz55AAA','AnnualRevenue','20000'
```

You can use the SF\_UpdateAccount stored procedure as a template for building your own specialized stored procedures. See the file **Create**

**SF\_UpdateAnnualRevenue.sql** for an example. Then, use the following SQL to update the Annual Revenue of an account.

```
exec SF_UpdateAnnualRevenue '00130000009DCEcAAO', 30000
```

Deleting rows with SQL has the same caveats. For best performance with deletion by Id, use an OPENQUERY clause in the SQL statement. An example of a stored procedure that deletes Accounts by Id is in the file **Create SF\_DeleteAccount.sql**.

For maximum scalability, please consider using the **sf\_TableLoader** stored procedure instead of SQL Update or Delete statements. The **sf\_TableLoader** stored procedure takes advantage of the ability to batch together requests to the salesforce.com api.

### **Joining Salesforce.com Tables**

Using joins, you can retrieve data from two or more tables based on logical relationships between the tables. Joins indicate how SQL Server should use data from one table to select the rows in another table.

Joins can be specified in either the FROM or WHERE clauses. The join conditions combine with the WHERE and HAVING search conditions to control the rows that are selected from the base tables referenced in the FROM clause.

Specifying the join conditions in the FROM clause helps separate them from any other search conditions that may be specified in a WHERE clause.

**In addition, consider using the OPENQUERY and SOQL feature (see above) for maximum performance when joining to salesforce.com tables.**

### **Analyzing Performance when Joining Tables**

The SQL Server Distributed Query Optimizer will choose a plan for every SQL statement that executes. Often, the plan chosen will be the most efficient and there will be no need to modify your SQL.

Should you suspect a poorly performing plan, use the Query Analyzer and enter the text of the SQL statement. Remember to use the 4 part naming convention for the Salesforce.com tables, i.e. SALESFORCE...Account.

Choose the **Display Estimated Execution Plan** option from the **Query** menu to view the execution plan.

While a full discussion of execution plans is beyond this document, most SQL Select with join statements involving Salesforce.com data will choose to either return the entire result set of a table or read the needed rows with a parameterized query.

For example, consider the following SQL Select:

```
Select T1.Name, T2.Salutation, T2.FirstName, T2.LastName
from SALESFORCE...Account as T1, SALESFORCE...Contact as T2
where T1.Id = T2.AccountId and T1.AnnualRevenue > 20000
```

Here is the initial execution plan:

```
|--Hash Match(Inner Join, HASH:
([SALESFORCE]...[Account].[Id])=([SALESFORCE]...[Contact].[AccountId]),
RESIDUAL:([SALESFORCE]...[Contact].[AccountId]=[SALESFORCE]...[Accou
nt].[Id]))
```

```
  |--Remote Query(SOURCE:(SALESFORCE), QUERY:(SELECT T1."Id"
Col1004,T1."Name" Col1005 FROM "Account" T1 WHERE
T1."AnnualRevenue">(20000.0000)))
```

```
  |--Remote Query(SOURCE:(SALESFORCE), QUERY:(SELECT
T2."AccountId" Col1007,T2."LastName" Col1010,T2."FirstName"
Col1008,T2."Salutation" Col1011 FROM "Contact" T2))
```

This plan will bring down from the Salesforce.com server all of the Contact records. If most of our Accounts have Annual Revenue of > 20000, then the plan is efficient because most of the Contact records will be needed.

If, however, only 3 Accounts have AnnualRevenue > 20000 and the other 1000 Accounts do not, then the plan is inefficient. The Contact query will be retrieving more Contact records than we actually need to build the result set.

Let's change the SQL Select to use an inner remote join:

```
Select T1.Name, T2.Salutation, T2.FirstName, T2.LastName
from SALESFORCE...Account as T1
inner remote join SALESFORCE...Contact as T2 on T1.Id = T2.AccountId
where T1.AnnualRevenue > 20000
```

Now the execution plan shows a different choice.

```
|--Nested Loops(Inner Join, OUTER
REFERENCES:([SALESFORCE]...[Account].[Id]))
```

```
  |--Remote Query(SOURCE:(SALESFORCE), QUERY:(SELECT T1."Id"
Col1010,T1."Name" Col1011 FROM "Account" T1 WHERE
T1."AnnualRevenue">(20000.0000)))
```

```
  |--Remote Query(SOURCE:(SALESFORCE), QUERY:(SELECT
T2."Salutation" Col1007,T2."FirstName" Col1004,T2."LastName"
Col1006 FROM "Contact" T2 WHERE T2."AccountId"=?))
```

In the Contact Query, we will now use a parameter in the query ("AccountId"=?) to read only the contact records we need. This is a much more efficient way to get the same result.

### **Using BIT datatype with DBAmp**

When returning results to SQL Server, DBAmp must choose a datatype to use for salesforce.com Checkbox fields. DBAmp uses bit and populates the column with either the values of 0 (FALSE) or 1 (TRUE).

### **Using Dates with DBAmp**

When returning results to SQL Server, DBAmp converts Datetime values from UTC into the local timezone.

In addition, any datetime values used in a WHERE clause are assumed to be local times and not UTC times.

If you would prefer to have DBAmp always use UTC for all datetime values, you can modify the DBAmp registry settings with the following procedure. Note: this is not recommended but possible. Please contact [cdata.com](http://cdata.com) support to understand the ramifications of UTC and DBAmp.

1. Using the Start/Run option, run the **regedit** program.
2. Navigate to the following key: HKEY\_LOCAL\_MACHINE / Software / DBAmp .
3. Right click **DBAmp** and choose **New DWORD Value**. Name the key **NoTimeZoneConversion** (watch case and spelling).
4. Right click the newly created **NoTimeZoneConversion** and choose **Modify**. Then assign a value of 1.

### Using DBAmp System Tables (sys\_sf tables)

**Note: The DBAmp System tables should not be used. Instead, use the DBAmp System views in the next section. The reason for this is because the views in the next section now support Where clauses.**

In addition to the Salesforce.com tables, DBAmp also provides various system tables that you can access with SQL SELECT statements. These tables are read-only; they cannot be updated or deleted.

Also, **Select** statements for these tables cannot contain a WHERE clause. If you need to use a WHERE clause, define a user-defined-function that encapsulates the table. See **Create DBAMP UDFS.sql** for an example.

Table Name	Contents
sys_sfsession Select * from SALESFORCE...sys_sfsession	The sys_sfsession table contains information about the current Salesforce.com session. Some of the columns in this table are:  SessionId – Current Session Id OrganizationId – 18 char OrgId ServerURL – URL of SForce Server
sys_sfpicklists Select * from SALESFORCE...sys_sfpicklists	The sys_sfpicklists table contains information about the picklist values for each picklist field There is one row for each per picklist value. Some of the columns in this table are:  ObjectName – Name of object FieldName – Field of the above object PickListValue – A single picklist value PickListLabel – Label for the above value
sys_sfobjects Select * from SALESFORCE...sys_sfobjects	The sys_sfobjects table contains information about the Salesforce.com objects. There is one row for each object in your organization. Some of the columns in this table are:  Name – Name of object Createable – Is object createable ? Deletable – Is object deletable ? URLDetail – URL Detail for this object URLNew – URL New for this object

<p>sys_sffield</p> <p>Select * from SALESFORCE...sys_sffield</p>	<p>The sys_sffield table contains information about the Salesforce.com object fields. There is one row for each object field in your organization. Some of the columns in this table are:</p> <p>ObjectName – Name of object  Name – Name of the field  Createable – Is the field insertable ?  Type – Field Type using sf terminology  SQLDefinition – SQL Column definition</p>
------------------------------------------------------------------	---------------------------------------------------------------------------------------------------------------------------------------------------------------------------------------------------------------------------------------------------------------------------------------------------------------------------------------------------------------------------------------------------

**Using DBAmp System Views**

DBAmp provides five system views that can be used to view object, field, relationship, and user entity access metadata of a Salesforce Org. The DBAmp stored procedure, SF\_CreateSysViews, creates five views to view this data. The views are created by supplying the DBAmp linked server name to SF\_CreateSysViews:

**Exec SF\_CreateSysViews 'SALESFORCE'**

Where SALESFORCE is the name of the DBAmp linked server.

The above command creates five views: SALESFORCE\_Fields, SALESFORCE\_FieldsPerObject, SALESFORCE\_Objects, SALESFORCE\_Relationships, and SALESFORCE\_UserEntityAccess. The prefix of the view names are derived from the DBAmp linked server provided in the command.

These views can be accessed by any SQL SELECT statement. Unlike the DBAmp System Tables, **Select** statements for these tables support a **Where** clause.

Table Name	Contents
<p>SALESFORCE_Fields</p> <p>Select * from SALESFORCE_Fields</p> <p>Select * from SALESFORCE_Fields where ObjectName = 'Account'</p>	<p>The SALESFORCE_Fields view contains information about the Salesforce.com object fields. There is one row for each object field in your organization. Some of the columns in this view are:</p> <p>ObjectName – Name of object  FieldName – Name of the field  IsCreateable – Is the field insertable?  Type – Field Type using sf terminology</p>
<p>SALESFORCE_Objects</p>	<p>The SALESFORCE_Objects view contains information about the Salesforce.com</p>

<p>Select * from SALESFORCE_Objects</p> <p>Select ObjectName, KeyPrefix, IsEverCreatable from SALESFORCE_Objects where ObjectName = 'Contact'</p>	<p>objects. There is one row for each object in your organization. Some of the columns in this view are:</p> <p>ObjectName – Name of object  IsEverCreatable – Is object creatable?  IsEverDeletable – Is object deletable?  IsEverUpdatable – Is object updatable?  KeyPrefix – Prefix of object’s SF Id</p>
<p>SALESFORCE_Relationships</p> <p>Select * from SALESFORCE_Relationships</p> <p>Select * from SALESFORCE_Relationships where ParentObject = 'Account' and ChildObject = 'Contact'</p>	<p>The SALESFORCE_Relationships view contains information about the relationships between the Salesforce.com objects. There is one row for each relationship between objects in your organization. Some of the columns in this view are:</p> <p>ParentObject – Name of parent object  ChildObject – Name of child object  ParentToChildRelationshipName – relationship name in SOQL for the parent to child relationship</p>
<p>SALESFORCE_UserEntityAccess</p> <p>Select * from SALESFORCE_UserEntityAccess where UserId = '00530000000kQi6AAE'</p> <p><b>Note:</b> Where clause on UserId is required. UserId is the Id of a Salesforce user.</p>	<p>The SALESFORCE_UserEntityAccess view contains information about the Salesforce.com objects a Salesforce user can access. There is one row for each object a Salesforce user can access. Some of the columns in this view are:</p> <p>ObjectName – Name of object  IsCreatable – Is object creatable?  IsDeletable – Is object deletable?  IsUpdatable – Is object updatable?</p>
<p>SALESFORCE_FieldsPerObject</p> <p>Select * from SALESFORCE_FieldsPerObject where ObjectName = 'Account'</p> <p><b>Note:</b> Where clause on ObjectName is required. ObjectName is the name of a Salesforce object.</p>	<p>The SALESFORCE_FieldsPerObject view contains information about a Salesforce.com object’s fields. There is one row for each field in a specified Salesforce.com object. Some of the columns in this view are:</p> <p>ObjectName – Name of object  FieldName – Name of the field  IsCreatable – Is the field insertable?  Type – Field Type using sf terminology</p>



### Using Count() with salesforce.com objects

There are two methods of obtaining a row count of salesforce.com objects.

The first method uses the following SQL:

#### Select Count() from SALESFORCE...Account

This SQL statement executes by retrieving all the Id values of the object and counting the total number of Id values fetched. While this method performs quickly for small tables, large tables perform badly because all the Id's are fetched to the local SQL Server to be counted.

The second method performs much better because it takes advantage to the salesforce api SOQL Count function:

**Select \* from**

**OPENQUERY(SALESFORCE,'Select Count() from Account')**

In the OPENQUERY clause, replace **SALESFORCE** with the name of your link server. Also, notice that the table name **Account** is NOT prefixed with "**SALESFORCE...**".

### Using DBAmp to convert currency amounts to a default currency

International organizations can use multiple currencies in opportunities, forecasts, reports, and other currency fields. The administrator sets the "corporate currency," which reflects the currency of the corporate headquarters.

If an organization is multicurrency enabled, you can configure DBAmp to convert currency fields to a single currency. DBAmp uses the default currency of the salesforce.com user id configured in the link server. DBAmp converts currencies using the ConvertCurrency() function of the salesforce.com API.

Note that **the default is NOT to convert currencies**. You must set the registry entry ConvertCurrency in the DBAmp hive for currency conversions to occur. The ConvertCurrency registry setting is found under the following registry key:

**LOCAL\_MACHINE\SOFTWARE\DBAmp\ConvertCurrency**

A value of 1 causes the conversion to occur. A SQL restart is required after modifying this value.

SOQL statements entered via an OPENQUERY phrase do not honor this setting. If you need to convert currency inside an OPENQUERY, then use the CONVERTCURRENCY function:

```
select * from openquery(salesforce,  
'Select Id, convertcurrency(annualrevenue), ToLabel(type)
```

```
from Account')
```

### Using DBAmp to return translated values for picklists

If an organization uses multiple languages, you can configure DBAmp to return translated values for picklist fields by using the ToLabel function.

Note that **the default is NOT return translated values**. You must set the registry entry ToLabel in the DBAmp hive to use translated values. The ToLabel registry setting is found under the following registry key:

#### LOCAL\_MACHINE\SOFTWARE\DBAmp\ToLabel

A value of 1 causes the ToLabel function to be used. A SQL restart is required after modifying this value.

SOQL statements entered via an OPENQUERY phrase do not honor this setting. If you need to return translated values inside an OPENQUERY, then use the ToLabel function:

```
select * from openquery(salesforce,  
'Select Id, convertcurrency(annualrevenue), ToLabel(type)  
from Account')
```

### Retrieving Archived and Deleted records

Normally, the salesforce api does not return archived and deleted records as part of the result of a query. Therefore, the query result from DBAmp does not contain these records.

If you would like to include the archived and deleted records, add the \_QueryAll prefix to the table name. For example, the following query retrieves only the task records that have been archived:

```
Select * from SALESFORCE...Task_QueryAll  
where IsArchived = 'true'
```

You may also replicate all records including archived and task records to a local table by using the sf\_replicateIAD stored procedure. See the SF\_ReplicateIAD section in chapter [DBAmp Stored Procedure Reference](#).

### Using Column Subset views

Objects in salesforce that contain over 325 columns may produce an error when either replicated or refreshed. The error occurs because the maximum limit of the Select query statement in the salesforce api is 10,000 characters. A large number of columns in an object will produce a Select query larger than 10,000 characters.

The solution is to take advantage of Column Subset views. These views represent a user specified subset of the columns designed to 'fit' within the 10,000 character limit.

By attaching a specific suffix to the table name, DBAmp will include only those columns with names that fall within the alphabetic range. For example, the following SQL statement will return all columns with names beginning with any letter between A and M inclusive:

```
Select * from SALESFORCE...Account_ColumnSubsetAM
```

Some system columns are returned unconditionally for every subset view. The Id, SystemModstamp, LastModifiedDate, and CreatedDate columns are always returned.

The suffix must have the following format: a single underscore, the word ColumnSubset and two single letters indicating the alphabetic range.

In order to retrieve a full copy of the object data, use two or more column subset views. For example, to replicate a large Account using column subset views use the following command:

```
Exec sf_replicate 'SALESFORCE','Account_ColumnSubsetAM'
```

```
Exec sf_replicate 'SALESFORCE','Account_ColumnSubsetNZ'
```

Note that there is nothing special about the column partition used. Account\_ColumnSubsetAK and Account\_ColumnSubsetLZ would work equally as well.

Column Subset Views can be used in Select statements (but not OPENQUERY) as well as the sf\_replicate and sf\_refresh stored procedures.

## **DBAmp and Salesforce API call Counts**

Like all third party salesforce.com tools, DBAmp uses the salesforce.com api to send and receive data from salesforce.com. Every salesforce.com customer has a limit on the total number of API calls they can execute, org wide, from all tools they are using. This limit is found on the Company Information screen in the salesforce.com application.

Here are some rough guidelines for api call counts for various operations in DBAmp:

**SELECT against link server tables, SF\_Replicate and SF\_Refresh** – DBAmp requests data in batches of 2000 records. The salesforce server may reduce that amount based on the width of the row. Our experience has been that the average batch size is 1000. So for every 1000 rows of data retrieved = 1 API call

**UPDATE and INSERT statements** – 1 api call for each record updated or inserted.

**SF\_TableLoader without the bulkapi switch** – 1 api call for each batch of 200 records.

**SF\_TableLoader with the bulkapi switch** – 1 api call for each batch of 10,000 records. If you use the batchsize option, then 1 api call per batchsize

There are other miscellaneous calls DBAmp makes to fetch schema data. These api calls are in addition to the above guidelines.

## Big Objects Support

Big objects let you store and manage massive amounts of data on the Salesforce platform. Big objects have \_\_b appended to the end of their API name. DBAmp supports SOQL with big objects and certain DBAmp stored procedures support big objects. For more information on big objects, see the following link: [https://developer.salesforce.com/docs/atlas.en-us.bigobjects.meta/bigobjects/big\\_object.htm](https://developer.salesforce.com/docs/atlas.en-us.bigobjects.meta/bigobjects/big_object.htm)

DBAmp support for big objects is **read-only**. DBAmp does **not** support inserting or updating big objects.

### SOQL with Big Objects

Salesforce allows only **indexed fields** on the big object to be queried. Below are examples to query big objects with DBAmp:

This query will return all the indexed fields in the Customer\_Interaction\_\_b big object:

```
select * from SALESFORCE...Customer_interaction__b
```

This query will return all indexed fields where the game platform is ps3 and the Account is as specified:

```
select Game_Platform__c, Account__c, Play_date__c from  
SALESFORCE...Customer_Interaction__b  
where Game_Platform__c = 'ps3' and Account__c = '0013000001L9BMSAA3'
```

**Note:** all three fields in the select clause are indexed fields on the Customer\_Interaction\_\_b object

This query uses openquery to select all of the indexed fields in the Customer\_Interaction\_\_b big object:

```
select * from Openquery(SALESFORCE, 'Select * from Customer_Interaction__b')
```

## **Replicating a Big Object**

Only the **indexed fields** of the big objects will be in the local copy created by the SF\_Replicate or SF\_BulkSOQL stored procedure. The following DBAmp Stored Procedures are supported with big objects:

- SF\_Replicate
- SF\_BulkSOQL

It is recommended to use the BulkAPI to create a local copy of a big object. This is because big objects contain millions to billions of records. Therefore, the BulkAPI will perform much better on big objects than the SOAP API. To use the BulkAPI, either use SF\_Replicate with the bulkapi option or use SF\_BulkSOQL.

To run the SF\_Replicate stored procedure with the BulkAPI option and make a local copy, use the following command:

```
Exec SF_Replicate 'SALESFORCE', 'Customer_Interaction__b',  
'bulkapi'
```

where 'SALESFORCE' is the name you gave your linked server at installation and Customer\_Interaction\_\_b is the Salesforce.com big object to copy.

To run the SF\_BulkSOQL stored procedure and make a local copy, use the command below. Note the use of the relationship field for the Account object, Account\_\_r. For more information on using relationship fields, see the link to the Salesforce documentation on big objects above:

```
Exec SF_BulkSOQL 'SALESFORCE', 'Customer_Interaction__b', "",  
'Select *, Account__r.Name from Customer_Interaction__b'
```

**Note:** SF\_Replicate using the SOAP API is supported but avoid using it due to large record counts in big objects.

## **Using DBAmp Stored Procedures with Big Objects**

The following stored procedures are not supported with big objects:

- SF\_Refresh
- SF\_BulkOps
- SF\_TableLoader
- SF\_RefreshIAD
- SF\_ReplicateIAD

## Platform Events Support

Platform events are the event messages that apps send and receive to take further action. Platform events simplify the process of communicating changes and responding to them. Platform events are defined in Salesforce in the same way that you define custom objects. Platform event objects have `__e` appended to the end of their API name. DBAmp supports only inserting into platform event objects. For more information on platform event objects, see the following link:

[https://developer.salesforce.com/docs/atlas.en-us.platform\\_events.meta/platform\\_events/platform\\_events\\_intro.htm](https://developer.salesforce.com/docs/atlas.en-us.platform_events.meta/platform_events/platform_events_intro.htm)

DBAmp support for platform event objects is **inserting only** using `SF_TableLoader`. DBAmp does **not** support any other operation and platform event objects are **not queryable**.

### Inserting into a Platform Event using SF TableLoader

To run the `SF_TableLoader` stored procedure using the SOAP API and insert a record into the `PETest__e` platform event object, use the following command:

```
Exec SF_TableLoader 'Insert', 'SALESFORCE', 'PETest__e_Insert'
```

Where `'Insert'` is the `SF_TableLoader` operation, `'SALESFORCE'` is the name you gave your linked server at installation, and `PETest__e_Insert` is the name of the input table.

To run the `SF_TableLoader` stored procedure using the BulkAPI 2.0 and insert a record into the `PETest__e` platform event object, use the following command:

```
Exec SF_TableLoader 'Insert:bulkapi', 'SALESFORCE',  
'PETest__e_Insert'
```

**Note:** The name of the platform event object ends in `__e`. **Insert** is the only operation that can be used with platform event objects for `SF_BulkOps` and `SF_TableLoader`. Platform event objects are **not queryable**.

### Inserting into a Platform Event using SQL Insert statements

To insert an event using a SQL Insert, pass the value for the event custom fields. For example:

```
insert into salesforce...PETest__e  
(EventMessage__c) VALUES ('test msg')
```

## Chapter 3: Making Local Copies of Salesforce Data

One common usage of DBAmp is to make periodic copies of Salesforce.com data into a local SQL Server database. Using a combination of Microsoft SQL Server jobs scheduled by the SQL Server Agent and DBAmp, you can import data from Salesforce.com and make local mirrored table copies.

The local mirrored tables are all located in a single database that you create. On a schedule you setup, a job runs that backups the current local table into a table name ending with `_Previous`. The job then drops the current mirrored table and renames the `_Previous` table to the correct object name.

You can setup retry options if the job is unable to run, perhaps delaying an hour and retrying again.

By default, DBAmp does not download the values of Base64 fields but instead sets the value to NULL. This is done for performance reasons. If you require the actual values, modify the Base64 Fields Maximum Size using the DBAmp Configuration Program to some value other than 0.

### **How SF\_Mirror works**

SF\_Mirror automatically chooses whether to do a full copy or a delta copy of the table. SF\_Mirror decides this based on a couple of criteria laid out below:

- SF\_Mirror creates a local table with the contents of the same object at Salesforce.com if the table does not already exist locally.
- If the table exists locally, SF\_Mirror decides whether to do a full copy or a delta copy of the table. SF\_Mirror makes this decision based on the created date of the local table (the last time the table was replicated).
- If the created date of the local table is **more than 7 days old**, SF\_Mirror will make a **full copy** of the table.
- If the created date of the local table is **less than 7 days old**, SF\_Mirror will do a **delta copy** of the table.
- If there are any **schema changes** detected, SF\_Mirror will make a **full copy** of the table.

The name of the local table is the same name as the Salesforce.com object (i.e. Account). By default, SF\_Mirror uses the **BulkAPI (With PKChunk header where applicable)** when making a full copy of the table locally. **Important Note:** if the table has been mirrored locally, SF\_Mirror will use the SOAP API when the row count of the local table is below 20,000, and the BulkAPI when the row count is above 20,000 when doing a full copy. In

addition, SF\_Mirror creates a primary key on the Id field of the local table and preserves any secondary indexes on the local table.

**Note:** SF\_Mirror creates Boolean fields on Salesforce.com as the **BIT** field data type in SQL Server. SF\_Mirror **ignores** the "Use Bit Column Type" registry setting in the DBAmp Configuration Program. The following is an example of a query with one of these fields:

**Select \* from Account where IsDeleted = 'true'**

**How to run the SF\_Mirror proc to make a local copy**

Now you are ready to run the stored procedure.

To run the SF\_Mirror stored procedure and make a local copy, use the following commands in Query Analyzer:

**Use "salesforce backups"**

**Exec SF\_Mirror 'SALESFORCE', 'Account'**

where 'SALESFORCE' is the name you gave your linked server in at installation and Account is the Salesforce.com object to copy.

You can also setup a SQL Server job to run SF\_Mirror on the schedule needed.

1. Go to the jobs subtree in Enterprise Manager and right click to create a new job.

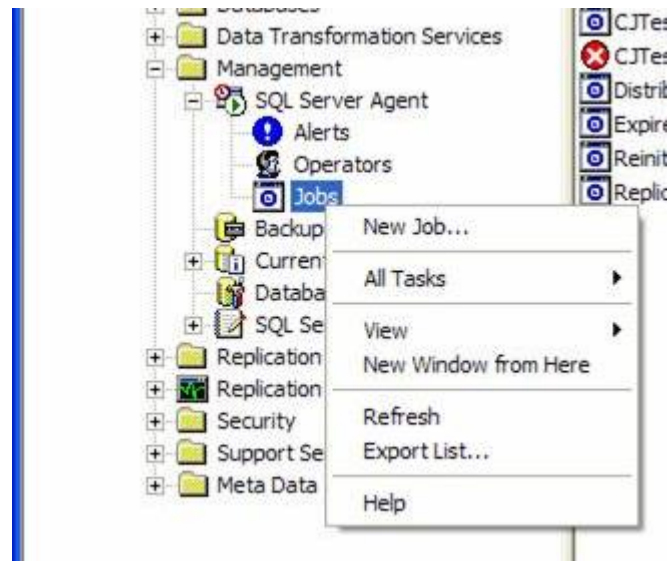

2. Create a job with one job step with the following:

**EXEC SF\_Mirror 'SALESFORCE', 'Account'**



where **SALESFORCE** is the name of your linked server and **Account** is the name of the object. Be sure to set the database to the database you created earlier. Under the Advanced tab, setup the retry options.

Because the SF\_Mirror proc generates substantial output, be sure to check the output to table option to capture the output. Also check **the Append output to job history** option.

3. Modify the job schedule for your execution schedule. You can also execute the job now by right-clicking the newly created job and choosing **Start Job**.

### Viewing the job history

The output from the DBAmp stored procedures can be long and is often truncated in the normal job history. For this reason, you should modify the job step to retain the job output in a table or file.

To retain the entire step output, edit the job step and navigate to the Advanced tab. Check "Route to table" to have SQL Server retain the entire message output in a table.

To view the output, return to the Advanced tab and click View.

### Mirroring all Salesforce Objects

You can use the SF\_MirrorAll stored procedure to mirror all of your Salesforce objects (including custom objects). When run, the SF\_MirrorAll proc compiles a list of all existing salesforce objects and calls the SF\_Mirror stored procedure for each object.

Salesforce objects that cannot be queried via the salesforce api with no where clause (like ActivityHistory) will NOT be included. In addition, Chatter Feed objects are also skipped by the sf\_MirrorAll stored procedure because of the excessive api calls required to download those objects. You can modify the stored procedures to include the Feed objects if needed.

**Note:** SF\_Mirror assumes that there are no foreign keys defined on the current set of local tables.

### How to run the SF\_MirrorAll proc to replicate all objects

Now you are ready to run the stored procedure.

To run the SF\_MirrorAll stored procedure and make a local copy, use the following commands in Query Analyzer:

**Use "salesforce backups"**

**Exec SF\_MirrorAll 'SALESFORCE'**

where 'SALESFORCE' is the name you gave your linked server in at installation.

You can also create a job to run the SF\_MirrorAll procedure on a periodic basis.

### **Copying only the rows that have changed**

Once SF\_Mirror has created an initial set of local, mirrored tables, subsequent calls to SF\_Mirror will automatically keep those tables up-to-date by downloading inserted, updated and deleted rows since the last run of SF\_Mirror.

### **Including Archived and Deleted rows in the local copy**

SF\_Mirror **does not** include archived and deleted records of the Salesforce.com object when making a **copy** of Salesforce data by default. To include the archived and deleted records of the Salesforce.com object in the **copy** of Salesforce data, add the optional queryall switch.

For example, to use the queryall option with SF\_Mirror:

**Exec SF\_Mirror 'Salesforce', 'Account', 'queryall'**

SF\_Mirror will retain the permanently deleted rows from run to run. Once you begin to use queryAll option for a table, all future SF\_Mirror calls for that table **MUST USE** queryAll. If you run SF\_Mirror without the queryAll option, you will lose all the permanently deleted rows in the local table.

### **How to run the SF\_Mirror proc without using xp\_cmdshell**

In some SQL Server environments, the use of xp\_cmdshell may be restricted. In this case you can use a CmdExec feature of the SQL job step to run the underlying replicate program directly (i.e. instead of using the **SF\_Mirror** stored procedure). The name of the exe is DBAmpAZ.exe and is located in the DBAmp Program Files directory. Normally the directory is c:\Program Files\DBAmp, but DBAmp may installed in a different location.

The DBAmpAZ.exe program takes the following 6 parameters:

1. **Command:** mirrorcopy  
**Note:** must explicitly use mirrorcopy as the command when using the CmdExec feature to run the replicate program directly.
2. **Salesforce Object:** The name of the Salesforce object to mirror locally.
3. **SQL Server Name:** The name of the SQL instance to connect to.
4. **SQL Database Name:** The name of the database to connect to. Enclose in double quotes if the name contains a blank.
5. **Link Server Name:** The name of the DBAmp link server.

6. **Options:** Must be either a combination of options or "". Options are handled the same way as the **SF\_Mirror** proc.

**Note:** if "" is specified as the option, bulkapi will be used.

**Ex.-** pkchunk,batchsize(50000)

Here is an example of a complete command:

```
"C:\Program Files\DBAmp\DBAmpAZ.exe" MirrorCopy Account BUDDY  
"salesforce backups" SALESFORCE "pkchunk,batchsize(50000)"
```

Note that even though the command appears on multiple lines in this document, the command must be entered as a single line in the job step. Also, notice the use of double quotes around both the program and the database. This is required because those values contain blanks.

When setting up a job step to call the program directly, you must change the **Type** of the job step to: **Operating System (CmdExec)**. Then enter your complete command in the Command text box. Again, the command must be on a single line.

The DBAmpAZ.exe program returns 0 for a successful completion and -1 if any rows failed. Ensure that the **Process exit code of a successful command** is 0 (zero). A -1 will be returned for situations where the replicate failed.

#### **Best Practices Incorporated into SF\_Mirror**

Our recommendation is to run SF\_Mirror either hourly, nightly or weekly. In the salesforce api, changes in formula fields will NOT be flagged as changed records. Therefore, if you have formula fields on objects and only their value changes, the record will not be picked up by sf\_mirror when doing a delta copy. This is because the salesforce api does not update the last modified date of that record for a formula field change. Therefore, SF\_Mirror will automatically do a full copy every 7 days to pick up these formula field changes.

Large binary blobs may not be downloaded if their size is greater than MaxBase64Size in the DBAmp registry. See MaxBase64Size in the DBAmp Registry Settings chapter.

#### **Using the DBAmpTableOptions Table**

Use the DBAmpTableOptions table to skip tables that are not needed locally in the SF\_Mirror, and SF\_MirrorAll stored procedures.

**Note:** the DBAmpTableOptions table is the replacement for the DBAmpProcOptions table and the TablesToSkip table.

Additionally, use the DBAmpTableOptions table to provide options for tables when using the SF\_Mirror, and SF\_MirrorAll stored procedures

The DBAmpTableOptions table contains four columns. Those four columns are described below:

**TableName** – The name of the Salesforce object. There can only be one row per Salesforce object in this table. This column **cannot** be null.

**Options** – Any options that can be specified in the options parameter of the SF\_Mirror stored procedures. This includes: bulkapi, pkchunk, batchsize, soap, subset, etc. This column **can** be null.

**SkipTable** – This is a bit column. Specify 1 to skip the Salesforce object in the SF\_MirrorAll stored procedures. The **default** is 0 to not skip the Salesforce object.

**Comments** – Any comments made by the DBAmp user as to why the Salesforce object entry is in the DBAmpTableOptions table. This column **can** be null.

A couple examples below for individual tables:

1. To skip the AcceptedEventRelation table from being replicated or refreshed locally and provide a reason for doing so, run the following command in the Salesforce Backups database:

```
Insert Into DBAmpTableOptions (TableName, SkipTable, Comments)
Values ('AcceptedEventRelation', 1, 'Not needed locally')
```

2. To use the pkchunk and batchsize options SF\_Mirror and SF\_MirrorAll when the Account table is being replicated locally and provide a reason for doing so, run the following command in the Salesforce Backups database:

```
Insert Into DBAmpTableOptions (TableName, Options, Comments)
Values ('Account', 'pkchunk,batchsize(50000)', 'Use pkchunk when
replicating Account')
```

In addition to specifying individual table names, wildcard names can also be specified. For example, %Share or Solution%. %Share would skip every table name that ends with Share. Solution% would skip every table that starts with Solution.

A couple examples below:

1. To skip all tables that end with History from being replicated or refreshed locally and provide a reason for doing so, run the following command in the Salesforce Backups database:

```
Insert Into DBAmpTableOptions (TableName, SkipTable, Comments)
Values ('%History', 1, 'Not needed locally')
```

2. To use the bulkapi option with SF\_Mirror and SF\_MirrorAll when all tables that end with Share are being replicated locally and provide a reason for doing so, run the following command in the Salesforce Backups database:

Insert Into DBAmpTableOptions (TableName, Options, Comments)  
Values ('%Share', 'bulkapi', 'Use bulkapi when replicating any table  
that ends with Share')

3. To use the pkchunk option SF\_Mirror and SF\_MirrorAll when using ColumnSubset on the Account table and provide a reason for doing so, run the following command in the Salesforce Backups database:

Insert Into DBAmpTableOptions (TableName, Options, Comments)  
Values ('Account', 'pkchunk', 'Use pkchunk when replicating  
Account\_ColumnSubsetAM and Account\_ColumnSubsetNZ')

**Note:** When using the DBAmpTableOptions table with a ColumnSubset table, enter the Salesforce object name as the TableName. For example, if the ColumnSubset table is Contact\_ColumnSubsetAM, the TableName to enter is Contact.

4. To skip all tables except tables that start with Account from SF\_MirrorAll, run the following commands in the Salesforce Backups database:

Insert Into DBAmpTableOptions (TableName, SkipTable, Comments)  
Values ('%', 1, 'Used to skip all tables from being  
replicated/refreshed')

Insert Into DBAmpTableOptions (TableName, Options, SkipTable,  
Comments) Values ('Account%', 'bulkapi', 0, 'Used to  
replicate/refresh all tables that start with Account')

**Note:** The '%' wild card character with SkipTable set to 1 tells SF\_MirrorAll to skip every table.

**Individual table names override wildcard names. For example, if %Share and AccountShare are specified in the DBAmpTableOptions table, the AccountShare entry will be chosen over the %Share entry.**

**Note:** The DBAmpTableOptions table is maintained by the user of DBAmp and is not overwritten when DBAmp is upgraded or the Create DBAmp SPROCS are executed to update the DBAmp stored procedures. The DBAmpTableOptions table also impacts the older SF\_ReplicateAll and SF\_RefreshAll stored procedures.

### **Making Local Copies with a Subset of Columns**

Some customers do not want all columns of an object and only want a subset of the columns locally. SF\_BulkSOQL and SF\_BulkSOQL\_Refresh solve this need. SF\_BulkSOQL uses the BulkAPI to create a local copy based on any SOQL query provided.

Once you have created an initial set of local, replicated tables with the subset of columns, you can keep those tables up-to-date by using the SF\_BulkSOQL\_Refresh stored procedure. The SF\_Bulk\_SOQL\_Refresh stored procedure attempts to 'sync' the local table created by the SOQL query, without having to download the entire

result set again. **Note:** There are restrictions on which SOQL queries can be used with SF\_BulkSOQL\_Refresh.

For more information, see the SF\_BulkSOQL and SF\_BulkSOQL\_Refresh stored procedure reference in the chapter entitled DBAmp Stored Procedure Reference.

### **Making Local Copies as Temporal Tables**

Temporal tables are system-versioned tables designed to keep a full history of data changes and allow easy point in time analysis. DBAmp provides functionality to make local copies of Salesforce objects in SQL Server. SF\_Mirror can be used to make temporal tables of Salesforce objects or with a subset of columns (equivalent to SF\_BulkSOQL).

For more information on SQL Server temporal tables and how to query them, take a look at the following link: <https://docs.microsoft.com/en-us/sql/relational-databases/temporal-tables?view=sql-server-2017>

Before using DBAmp to make local copies of Salesforce objects as temporal tables, consider the following:

- **SQL Server 2016** or higher is required.
- The local copy made on a Salesforce object will contain two local tables: the current table and temporal table. The current table name in SQL Server will be the name of the Salesforce object (ex.- Account). The temporal table name in SQL Server will be the name of the Salesforce object with \_Temporal appended to the end (ex.- Account\_Temporal).
- Once a local copy of a Salesforce object is made as a temporal table, the SF\_Mirror temporal option **must** always be used on that object moving forward. There must be **no** mixing of temporal, IAD, or regular options / stored procedures on an object.
- We recommend creating the local copies as temporal tables in a separate database as copies being made using the IAD or regular options / stored procedures.
- **Do not** make schema changes directly to the current or temporal tables locally. Schema changes made on Salesforce are allowed.
- Any deleted fields on Salesforce are **not** removed from the local copy. The field will remain in the current and temporal table locally.
- Salesforce object must contain a **SystemModstamp** field.
- Query the current table for the current reflected data on Salesforce.com. For example:

```
Select Id, Name, AnnualRevenue from Account
```

- Query the temporal table for a full history of data changes made to the object on Salesforce.com. For example:

```
Select * from Account FOR SYSTEM_TIME Between '2018-01-31 17:44:04' and '2019-01-31 17:44:04'
```

- The **Id** and **SystemModstamp** columns **must** be included in the SOQL statement.

For more information on the SF\_Mirror stored procedure when using the temporal options, see the SF\_Mirror stored procedure references in the chapter entitled *DBAmp Stored Procedure Reference*.

### **Formula Fields with Large Tables/Result Sets**

Whether formula fields exist in the object or result set being replicated locally, using SF\_Mirror with the temporal option, determines what DBAmp does with the current and temporal table.

If a formula field **exists** in the object or result set being replicated locally, DBAmp will **add all rows** in the current table to the temporal table. This means, if the local object or result set contains 5,000 records, if a formula field is found DBAmp will add all 5,000 records to the temporal table every time the stored procedure is ran. **Note:** this can cause the temporal table to grow at a very high rate.

If a formula field **does not exist** in the object or result set being replicated locally, DBAmp will only add the rows that were updated/changed to the temporal table. This means, if 5 records were changed on Salesforce, only those 5 records will be added to the temporal table when the stored procedure is run next.

### **Best Practices when using Temporal Tables**

- Temporal tables take up large amounts of storage. Therefore, make sure there is enough storage space in the database to handle this.
- Use SF\_Mirror with a subset of columns to only pull the fields/data needed locally instead of specifying a Salesforce object, which pulls all the fields and data in an object.

### **Syntax**

```
exec SF_Mirror 'linked_server', 'object_name', 'options'
```

where *linked\_server* is the name of your linked server and *object\_name* is the name of the object. There are several optional options you may include as well, but **temporal** must be one of them.

### **Example**

The following example creates a mirrored local Account table with the current data on Salesforce.com using the SALESFORCE linked server.

```
exec SF_Mirror 'SALESFORCE', 'Account', 'temporal'
```



## Chapter 4: Bulk Insert, Upsert, Delete and Update into Salesforce using SF TableLoader

Normal SQL Insert, Delete and Update statements are processed one at a time and are not sent in batches to Salesforce.com. To perform bulk operations, use the **SF\_TableLoader** stored procedure.

Conceptually, **the SF\_TableLoader** proc takes as input a local SQL Server table you create that is designated as the "input" table. The input table name must begin with a valid Salesforce object name followed by an underscore and suffix. For example, **Account\_Load** and **Account\_FromWeb** are valid input table names. **XXX\_Load** is not a valid input table name (XXX is not a valid Salesforce.com object).

**Do not allow other applications to write to the input table while SF\_TableLoader is running.**

### **Differences between SF\_BulkOps and SF\_TableLoader**

**NOTE: SF\_Bulkops has been deprecated and will be removed from future versions of DBAmp.**

There are differences between SF\_BulkOps and SF\_TableLoader. Those differences are listed below:

- SF\_TableLoader can use the **BulkAPI2** functionality of Salesforce.
- All results from Salesforce are written in a **Result** table, instead of being written back to the input table. The Result table is named: input table + **\_Result**. For example, if the input table is **Account\_Insert**. The Result table is **Account\_Insert\_Result**
- SF\_TableLoader automatically determines the Salesforce API to use based off the input table given. This is to maximize SF\_TableLoader's performance.
- No **Error** column is required in the input table. SF\_TableLoader writes errors into the Error column of the result table, not the input table.
- The Result table contains the successful results, failed results, and unprocessed results from Salesforce.

### **Why SF\_TableLoader over SF\_BulkOps?**

**NOTE: SF\_Bulkops has been deprecated and will be removed from future versions of DBAmp.**

There are a few reasons to use SF\_TableLoader over SF\_BulkOps. The reasons are listed below:

- SF\_TableLoader is much more performant than SF\_BulkOps or SF\_BulkOps when using the bulkapi, especially on large input tables. Below is an example of this:

Type	500 rows	5,000 rows	25,000 rows	250,000 rows
SF_BulkOps	:03	:33	2:27	24:07
SF_BulkOps - bulkapi	:18	:46	2:12	17:08
SF_TableLoader – bulkapi2	:06	:35	1:06	2:37
SF_TableLoader - bulkapi	:20	:21	:40	1:49

- SF\_TableLoader can use the BulkAPI2 API if explicitly specified via the bulkapi2 switch. Ex: exec SF\_TableLoader 'Update:bulkapi2', 'SALESFORCE', 'Account\_Update'
- SF\_TableLoader writes results of the operation to an \_Result table. Therefore, the input table and its data are not being touched by SF\_TableLoader.
- SF\_TableLoader chooses which Salesforce API (soap, bulkapi) to use based on the input table provided.

#### Checking the Column Names of the Input Table

The input table must contain a column named **Id** defined as nchar(18). In SF\_TableLoader, an **Error** column is not required in the input table. SF\_TableLoader creates the Error column in the Result table. If an Error column is provided in the input table, SF\_TableLoader will ignore the Error column in the input table and write the messages to the Error column in the Result table. In addition, the input table can contain other columns that match the fields of the Salesforce object.

For example, below is a valid definition of an Account\_Load table:

```

Id          nchar(18)

Name        nvarchar(80)

AnnualRevenue    decimal(18, 2)

```

Note that in this example, the Account\_Load table does not contain most of the fields of the Account object.

How the input table is used depends on the operation requested. When using the above example table with an **Insert** operation, the missing fields are loaded as null values. When using the above example table with an **Update** operation, the Name and AnnualRevenue fields becomes the only fields updated on the Salesforce side. When using the above example table with a **Delete** operation, the Name and AnnualRevenue fields are ignored and the objects with the Id value are deleted.

The **SF\_TableLoader** proc looks at each field of the Salesforce object and tries to match it to a column name in the input table. Note that columns of the input table that do not match a field name are ignored. When using the BulkAPI2, these columns that are ignored do not show up in the Result table. Only the columns sent to Salesforce show up in the Result table. In addition, columns that match a computed field (like SystemModstamp) are ignored if they exist in the input table. When using the SOAP API or BulkAPI, all columns in the input table show up in the Result table.

The **SF\_TableLoader** proc will identify column names of the input table that do not match with valid Salesforce.com column names and produce a warning message in the output. Note that in a properly constructed input table you may also have other columns in the input table that are for your own use and that should be ignored as input to **SF\_TableLoader**. The **SF\_ColCompare** stored procedure will also compare column names and identify errors without having to run **SF\_TableLoader**.

You can easily have DBAmp generate a valid local table for any salesforce.com object by using the **SF\_Generate** stored procedure. **SF\_Generate** will automatically create an empty local table with all the proper columns of the salesforce.com object needed for that operation. See the chapter entitled DBAmp Stored Procedure Reference for more information on **SF\_Generate** and **SF\_ColCompare**.

**Using External Ids as Foreign Keys**

You can use external ID fields as a foreign key, allowing you to bulk create, update, or upsert records in a single step instead of querying a record to get the ID first.

To do this, modify the column name of the input table and add a period followed by the external ID field name. For example, let's look at bulk insert of contact records with the following table:

ID	LastName	AccountId.SAPXID__c	Error
	Emerson	C01203	
	Harrison	C01202	

In the first contact to be created ('Emerson'), the relationship to the Account is specified using the SAP Id of C01203.

Also, you must use the external id value for all rows of the input table.

You can use external ids as foreign keys when bulk inserting, updating, or upserting.

**Understanding the Error Column**

For all rows that were successfully processed, **SF\_TableLoader** writes the phrase "Operation Successful" to the Error column of the Result table.

Successfully processed rows can therefore be selected using the following SQL Select:

```
Select * from Account_Load_Result where Error like '%Operation Successful%'
```

Rows that were not successfully processed will contain either a row specific error or nothing if there was a global failure or they were unprocessed by Salesforce.

**Note:** The Error column is not required in the input table when using SF\_TableLoader. SF\_TableLoader handles the Error column for you. If an Error column is provided in the input table, SF\_TableLoader will ignore the Error column in the input table and write the messages to the Error column in the Result table.

### **Bulk Inserting rows into Salesforce**

When the operation requested is **Insert**, **SF\_TableLoader** reads each row of the input table, matches the columns to the fields of the Salesforce object, and attempts to insert the new object into Salesforce. **Important: SF\_TableLoader** attempts to insert all rows of the load table regardless of any existing values in the Id column. In other words, the Id column is ignored on input when doing an **Insert** operation.

After execution of the **SF\_TableLoader** proc, the Id column of the Result table is overwritten with the Id assigned by Salesforce for each successfully inserted row. If the row could not be inserted, the Error column in the Result table contains the error message for the failure.

### **Bulk Upserting rows into Salesforce**

When the operation requested is **Upsert**, **SF\_TableLoader** reads each row of the input table, matches the columns to the fields of the Salesforce object, and attempts to upsert the new object into Salesforce. You must specify which field to use as the External Id field in the **SF\_TableLoader** call. **Important: SF\_TableLoader** attempts to upsert all rows of the load table regardless of any existing values in the Id column. In other words, the Id column is ignored on input when doing an **Upsert** operation.

After execution of the **SF\_TableLoader** proc, the Id column of the Result table is overwritten with the Id assigned by Salesforce for each successfully upserted row. If the row could not be upserted, the Error column of the Result table contains the error message for the failure.

### **Bulk Updating rows into Salesforce**

When the operation requested is **Update**, the **SF\_TableLoader** reads each row of the input table, maps the columns to the fields of the Salesforce object, and attempts to update an object in Salesforce using the Id column of the input table.

**Important:** the input table should only contain columns for those fields that you want to update. If the data in a column is an empty string or

NULL, **SF\_TableLoader** will update that field on salesforce.com to be NULL. You may modify this behavior by using the following value for the operation: **Update:IgnoreNulls**. The **IgnoreNulls** option tells **SF\_TableLoader** to ignore null values in columns. The **IgnoreNulls** option can only be used with the SOAP API of Salesforce. Therefore, if you are using the **IgnoreNulls** option, you should also explicitly include the **soap** option as IgnoreNulls does not work with the BulkAPI of Salesforce. For example:

```
Exec SF_TableLoader 'Update:IgnoreNulls,soap','Salesforce','Account_Upd'
```

However, empty string values will still set the field on salesforce.com to NULL. For each row in the input table that failed to update, the Error column in the Result table will contain the error message for the failure.

### **Bulk Deleting rows from Salesforce**

When the operation requested is **Delete**, the **SF\_TableLoader** reads each row of the input table and uses the Id field to delete an object in Salesforce.

For each row in the input table that failed to delete, the Error column in the Result table will contain the error message for the failure.

### **Bulk HardDeleting rows from Salesforce**

When the operation requested is **HardDelete**, the **SF\_TableLoader** reads each row of the input table and uses the Id field to harddelete an object in Salesforce.

For each row in the input table that failed to harddelete, the Error column in the Result table will contain the error message for the failure.

### **Bulk UnDeleting rows from Salesforce**

When the operation requested is **UnDelete**, the **SF\_TableLoader** reads each row of the input table and uses the Id field to undelete an object in Salesforce.

You can identify deleted rows in a table with the following query:

```
Select Id from SALESFORCE...Account_QueryAll where IsDeleted='true'
```

**Note:** The **UnDelete** operation forces **SF\_TableLoader** to use the SOAP API of Salesforce.

### **Controlling the batch size with SF\_TableLoader**

**SF\_TableLoader** with the soap switch uses a default batch size of 200 rows (SOAP API). When using the bulkapi, SF\_TableLoader uses a default batch size of 10,000. You may need to reduce the batch size to accommodate APEX code on the salesforce.com server. To specify a different batch size, use the batchsize(xx) option after the operation.

For example, to set the batch size to 50:

```
Exec SF_TableLoader 'Update:soap,batchsize(50)','Salesforce','User_Upd'
```

```
Exec SF_TableLoader 'Update:batchsize(50)','Salesforce','User_Upd'
```

**Note:** The **batchsize** option is ignored if **SF\_TableLoader** uses the bulkapi2 API of Salesforce.

### Understanding a Sort Column when using SF\_TableLoader

In addition, the sort column can be used to reduce locking issues on salesforce. Salesforce recommends ordering a detail load table by the master record id to improve locking (See [https://developer.salesforce.com/page/Loading\\_Large\\_Data\\_Sets\\_with\\_the\\_Force.com\\_Bulk\\_API](https://developer.salesforce.com/page/Loading_Large_Data_Sets_with_the_Force.com_Bulk_API) ).

Here is a quick way you can add a Sort column to your load table. Assume that the load table is named Account\_upd1:

```
Alter table Account_upd1  
Add [Sort] int identity (1,1)
```

This adds a Sort column to the table that is a consecutive integer number.

Suppose you are uploading Contact records using a load table named Contact\_upd1. In this case, you could create a Sort column follows:

```
Alter table Contact_upd1  
Add [Sort] int identity (1,1)
```

Then insert the source data into the Contact\_upd1 table in AccountId order.

**SF\_TableLoader** will send the records to salesforce in AccountId order to reduce locking when inserting the contacts.

**Note:** The **Sort** column functionality should only be used if you are receiving locking issue errors from the Salesforce server.

### How to run the SF\_TableLoader proc

Now you are ready to run the stored procedure.

**Note:** The **SF\_TableLoader** stored procedure uses the xp\_cmdshell command. If you are not an SQL Server administrator, you must have the proper permission to use this command. See the SQL Server documentation under the topic xp\_cmdshell for more information. To quickly test, run the following sql in Query Analyzer:

```
Exec master..xp_cmdshell "dir"
```

To run the **SF\_TableLoader** stored procedure, use the following commands in Query Analyzer. Be sure your default database is **salesforce backups**.

```
Exec SF_TableLoader 'Insert', 'SALESFORCE', 'Account_Load'
```

Or

```
Exec SF_TableLoader 'Upsert','SALESFORCE','Account_Load',  
'ED__c' (where ED__c is the name of the external id field)
```

```
Exec SF_TableLoader 'Delete', 'SALESFORCE', 'Account_Load'
```

Or

```
Exec SF_TableLoader 'Update', 'SALESFORCE', 'Account_Load'
```

where 'SALESFORCE' is the name you gave your linked server at installation and Account\_Load is the name of the input table to use.

Similar to the **SF\_Replicate** proc, you can schedule the **SF\_TableLoader** proc using the SQL Server job agent.

#### How to run the SF\_TableLoader proc without using xp\_cmdshell

In some SQL Server environments, the use of xp\_cmdshell may be restricted. In this case you can use a CmdExec feature of the SQL job step to run the underlying tableloader program directly (i.e. instead of using the **SF\_TableLoader** stored procedure). The name of the exe is DBAmpAZ.exe and is located in the DBAmp Program Files directory. Normally the directory is c:\Program Files\DBAmp but DBAmp may be installed in a different location.

The DBAmpAZ.exe program takes the following 6 parameters:

1. **Operation:** Must be either **Insert, Delete, Update, Upsert, HardDelete, Undelete, or ConvertLead**. This is similar to the first parameter of **SF\_TableLoader**.
2. **Input Table:** The name of the local SQL table containing the data.
3. **SQL Server Name:** The name of the SQL instance to connect to.
4. **SQL Database Name:** The name of the database to connect to. Enclose in double quotes if the name contains a blank.
5. **Link Server Name:** The name of the DBAmp link server.
6. **Options:** The options that can be specified. These options include: soap, bulkapi, bulkapi2, batchsize(), ignorefailures, soapheaders(), externalid(), serial, parallel, and assignmentruleid(). For more information on these options, see the SF\_TableLoader section in Chapter 7.

Here is an example of a complete command using the soap option:

```
"C:\Program Files\DBAmp\DBAmpAZ.exe" update Account_Load BUDDY  
"salesforce backups" SALESFORCE "soap"
```

Note that even though the command appears on multiple lines in this document, the command must be entered as a single line in the job step.

Also, notice the use of double quotes around both the program and the database. This is required because those values contain blanks.

Here is an example of a complete command using no options:

```
"C:\Program Files\DBAmp\DBAmpAZ.exe" update Account_Load BUDDY "salesforce backups" SALESFORCE ""
```

The double quote, double quote (""") on the end is mandatory even when no options are specified.

Here is an example of a complete command using an external id and soap headers:

```
"C:\Program Files\DBAmp\DBAmpAZ.exe" upsert Account_Load BUDDY "salesforce backups" SALESFORCE "soapheaders(EmailHeader,triggerAutoResponseEmail,true),externalid(XID__c)"
```

When setting up a job step to call the program directly, you must change the **Type** of the job step to: **Operating System (CmdExec)**. Then enter your complete command in the Command text box. Again, the command must be on a single line.

The DBAmpAZ.exe program returns 0 for a successful completion and -1 if any rows failed. Ensure that the **Process exit code of a successful command** is 0 (zero). A -1 will be returned for situations where some of the rows succeeded and some failed. Use the error column of the Result table to determine the failed rows. Rows that succeeded do not need to be resubmitted.

Below is a screen shot of a sample job step calling the DBAmpAZ.exe.

Your command may be different depending on the install directory.

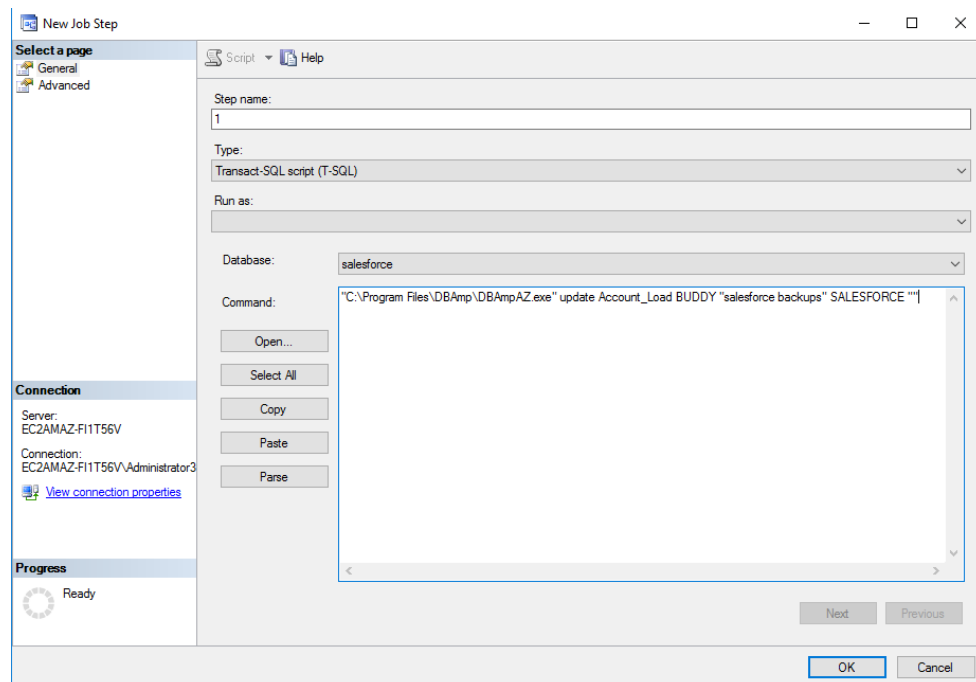



## SF\_TableLoader Sample Recipe

Below is a sample workflow of a typical process using SF\_TableLoader. Follow the steps below as a guide to use the SF\_TableLoader stored procedure. The following updates the Account object up on Salesforce.com:

1. Create the Input table if it does not exist:

```
if not exists (select * from INFORMATION_SCHEMA.TABLES
              where TABLE_NAME = 'Account_Update' AND TABLE_SCHEMA = 'dbo')
Begin
  Create Table Account_Update
  (
    Id nchar(18),
    Name nvarchar(255),
    AnnualRevenue decimal(18, 0)
  )
End
```

**Note:** The Id column must be included in the Input table no matter the operation being used.

2. Truncate the Input table to prepare new load:

```
truncate table Account_Update
```

**Note:** This step should be done every time to clean out and prepare the input table for the next load.

3. Load Input table with records to update to Salesforce:

```
Insert into Account_Update (Id, Name, AnnualRevenue)
Select Id, Name, AnnualRevenue
from Account
```

**Note:** This step is where the records that need to be pushed up to Salesforce are inserted into the Input table. We recommend avoiding Select Into statements as those lock the catalog when creating the Input table.

4. Update Salesforce with the records in the Input table:

```
exec SF_TableLoader 'Update', 'SALESFORCE', 'Account_Update'
```

**Note:** For more information on the operations that can be used and the syntax of SF\_TableLoader, refer to the *SF\_TableLoader* section in chapter entitled [DBAmp Stored Procedure Reference](#).

5. Check the results of the load:

```
Select Error
From Account_Update_Result
```

```
Where Error <> 'Operation Successful.'
```

**Note:** The results of the load are put into an `_Result` table. The name of the result table is the name of the Input table with `_Result` appended to the end. Any records that were successful will have 'Operation Successful' written to the Error column. Any records that failed will have the Salesforce error stating why in the Error column.

### Understanding SF\_TableLoader failures

When individual rows of the input table fail to complete the operation, **SF\_TableLoader** writes the error message in the Error column of the Result table. Thus, in a batch of 200 rows it is possible that 175 rows were successful and 25 rows failed.

The **SF\_TableLoader** stored procedure outputs an error message in the log indicating the **SF\_TableLoader** failed when 1 or more rows failed. The correct interpretation of this error message is that at least 1 row of the Result table contained an error. Rows that have a blank error message are unprocessed rows by Salesforce. In addition, **SF\_TableLoader** outputs messages indicating the total number of rows processed the number of rows that failed, the number of rows that succeeded, and the number of rows that were unprocessed.

If **SF\_TableLoader** is run in a job step, then the job step will fail if one or more rows contain an error. Again, the rows that contain a blank error message were unprocessed; the failure is thrown to indicate to the operator that at least one row failed.

### Using Optional SOAP Headers

The SOAP API allows you to pass additional SOAP Headers that alter the behavior of the **SF\_TableLoader** operation. The SOAP Headers are described in detail in the Salesforce.com API documentation:

[http://www.salesforce.com/us/developer/docs/api/Content/soap\\_headers.htm](http://www.salesforce.com/us/developer/docs/api/Content/soap_headers.htm)

The headers are specified in the form of 3 values separated by commas. The first value is the header name, the next value is the section name and the last value is the value for the section. The entire parameter is enclosed in quotes. If you are specifying multiple SOAP Headers, separate them with a semicolon. The salesforce.com API is case sensitive with respect to these values; use the exact token given in the Salesforce.com documentation.

For example, to use the default assignment rule for these inserted Leads you would add the following SOAP Header parameter:

```
Exec SF_TableLoader  
'Insert:soap','SALESFORCE','Lead_Test','AssignmentRuleHeader,useDefaultRule,true'
```

The DBAmp Registry settings can also be used to add SOAP headers. The difference is the SOAP header parameter on the **SF\_TableLoader** call is a "one-time" use. The DBAmp Registry settings apply the SOAP header to all

operations of DBAmp. Therefore, using the SOAP header parameter allows a finer control over the header usage.

Here are some other examples of SOAP headers:

Trigger auto-response rules for leads and cases: `'EmailHeader,triggerAutoResponseEmail,true'`  
 Changes made are not tracked in feeds: `'DisableFeedTrackingHeader,disableFeedTracking,true'`

Note: SOAP Headers force **SF\_TableLoader** to use the SOAP API of Salesforce.

### Converting Leads with SF\_TableLoader

**SF\_TableLoader** can be used to convert lead records to accounts/contacts/opportunities.

**Note:** Converting leads forces **SF\_TableLoader** to use the SOAP API of Salesforce.

The first step is to create a table to hold the information needed for the conversion. At minimum the table needs to have the following columns:

```
CREATE TABLE [dbo].[LeadConvert] (
    [LeadId] [nchar] (18) NULL,
    [convertedStatus] [nvarchar] (255) NULL,
    [Error] [nvarchar] (512) NULL,
    [AccountId] [nchar] (18) NULL,
    [OpportunityId] [nchar] (18) NULL,
    [ContactId] [nchar] (18) NULL
) ON [PRIMARY]
```

Additional columns listed below may be added to the table if the functionality of the column is needed.

Name	Type	Description
accountId	nchar(18) NULL	ID of the <a href="#">Account</a> into which the lead will be merged. Required only when updating an existing account, including person accounts. If no <code>accountID</code> column is specified, then the API creates a new account.  DBAmp will populate this column with the ID of the newly created Account.
contactId	nchar(18) NULL	ID of the <a href="#">Contact</a> into which the lead will be merged (this contact must be associated with the specified <code>accountId</code> , and an <code>accountId</code> must be specified). Required only when updating an existing contact. Important  If you are converting a lead into a <a href="#">person account</a> , do not specify the <code>contactId</code> or an error will result. Specify only the <code>accountId</code> of the person account.

Name	Type	Description
		<p>If no <code>contactID</code> is specified, then the API creates a new contact that is implicitly associated with the <a href="#">Account</a>.</p> <p>DBAmp will populate this column with the ID of the newly created Contact.</p>
<code>convertedStatus</code>	<code>nvarchar(255)</code> NULL	<p>Valid <code>LeadStatus</code> value for a converted lead. Required. To obtain the list of possible values, you must query the <code>LeadStatus</code> object. For example:</p> <pre>Select Id, MasterLabel from SALESFORCE...LeadStatus where IsConverted=true</pre>
<code>doNotCreateOpportunity</code>	<code>varchar(5)</code> NULL	<p>Specifies whether to create an <a href="#">Opportunity</a> during lead conversion (<code>false</code>, the default) or not (<code>true</code>). Set this flag to <code>true</code> only if you do not want to create an opportunity from the lead. An opportunity is created by default.</p>
<code>leadId</code>	<code>nchar(18)</code> NULL	<p>ID of the <a href="#">Lead</a> to convert. Required.</p>
<code>opportunityId</code>	<code>nchar(18)</code> NULL	<p>DBAmp populates the field with the Id of the newly created Opportunity</p>
<code>opportunityName</code>	<code>nvarchar(80)</code> NULL	<p>Name of the opportunity to create. If this column is not included, then this value defaults to the company name of the lead.</p>
<code>overwriteLeadSource</code>	<code>varchar(5)</code> NULL	<p>Specifies whether to overwrite the <code>LeadSource</code> field on the target <a href="#">Contact</a> object with the contents of the <code>LeadSource</code> field in the source <a href="#">Lead</a> object (<code>true</code>), or not (<code>false</code>, the default). To set this field to <code>true</code>, you must specify a <code>contactId</code> for the target contact.</p>
<code>ownerId</code>	<code>nchar(18)</code> NULL	<p>Specifies the ID of the person to own any newly created account, contact, and opportunity. If the client application does not specify this value, then the owner of the new object will be the owner of the lead.</p>
<code>sendNotificationEmail</code>	<code>varchar(5)</code> NULL	<p>Specifies whether to send a notification email to the owner specified in the <code>ownerId</code> (<code>true</code>) or not (<code>false</code>, the default).</p>

Use the following command to convert leads:

**Exec SF\_TableLoader 'ConvertLead', 'SALESFORCE', 'LeadConvert'**

Be sure to examine the Error column in the Result table after running the command to look for possible errors that may have occurred.

### Using IgnoreFailures Option with SF\_TableLoader

Without this option, if a **SF\_TableLoader** job runs and one record fails, it fails the entire job. Some customers want a certain amount of records to fail without it failing the entire job. The IgnoreFailures option in **SF\_TableLoader** allows for this functionality.

With the IgnoreFailures option, a number is specified for the percent of record failures allowed, without failing the entire job. For example, if 10 is entered for the IgnoreFailures option, 10 percent of the records in the table being used for **SF\_TableLoader** are allowed to fail, without failing the entire job. If less than 10 percent of the records in the table fail, the **SF\_TableLoader** job is successful. If more than 10 percent of the records in the table fail, the **SF\_TableLoader** job fails.

An example is laid out below:

In this example, up to 20 percent of the records in the Opportunity\_Load table can fail, without the **SF\_TableLoader** job failing. Use the following command to allow up to 20 percent of records in the Opportunity\_Load table to fail:

```
Exec SF_TableLoader 'Insert:IgnoreFailures(20)', 'SALESFORCE',  
'Opportunity_Load'
```

### Using AssignmentRuleId Option with SF\_TableLoader

The BulkAPI allows you to pass an AssignmentRuleId that specifies who the owner of a Case or Lead is. The AssignmentRuleId option can only be used with the **BulkAPI** and if the data is being pushed to either the **Case** or **Lead** objects.

Query the AssignmentRule table to obtain the AssignmentRuleId that is to be used to specify the owner of the Case or Lead:

```
Select * from SALESFORCE...AssignmentRule
```

Where SALESFORCE is the name of your linked server.

The AssignmentRuleId option is passed after the operation in the SF\_TableLoader command. To specify an AssignmentRuleId, use the assignmentruleid(xx) option after the operation:

```
exec SF_TableLoader 'update:bulkapi,assignmentruleid(01Q300000001Tp5EAE)',  
'SALESFORCE', 'Lead_Update'
```

**Note:** The AssignmentRuleId option can only be used with the **BulkAPI**. Therefore, if the input table contains **less** than 5,000 rows, the **bulkapi** option **must** also be specified after the operation. If the input table contains **more** than 5,000 rows, the **bulkapi** option **does not** have to be specified after the operation.

The BulkAPI is case sensitive with respect to the AssignmentRuleId value; use the exact AssignmentRuleId given in the AssignmentRule table.

**Note:** only **one** AssignmentRuleId can be given in the command.

## Chapter 5: Using SSIS with DBAmp

DBAmp can be used with SSIS to build complex integrations. Within SSIS, you can use DBAmp in two ways:

- **Pull data from salesforce.com** using the linked server
- Connecting to SQL Server and using the link server **to push data to salesforce.com.**

### **Using the linked server as an SSIS Source**

To bring salesforce data into SSIS as a data source, connect to the SQL instance that contains the linked server and use a Data Flow task in SSIS that reads data from salesforce.com using a SQL statement and a four part name (i.e. Select Id, Name from SALESFORCE...Account).

1. While in the Control Flow panel, drag and drop a **Data Flow Task** from the Toolbox. Right click on the new Data Flow Task and choose **Edit**. The Data Flow panel should now be displayed
2. From the Toolbox, drag and drop the **OLE DB Source** item onto the edit panel. Right click the new **OLE DB Source** item and choose **Properties**.
3. Set the **AlwaysUseDefaultCodePage** property to TRUE. This must be done for the DBAmp OLE DB Source to work correctly.
4. Now, right click on the **OLE DB Source** item and choose **Edit**. Set the **OLE DB Connection Manager** to the SQL Server connection. This should be the SQL Server where the DBAmp Linked Server resides.
5. **Data Access Mode** must be a SQL command.

Type your **SQL** statement directly into the **SQL Command Text** field. Be sure to use a four part name in the FROM clause (SALESFORCE...Account)

This OLE DB Source can now be used as the source of the data flow.

### **Pushing Data to Salesforce.com using SSIS**

The most scalable way to push data to salesforce.com is the sf\_TableLoader stored procedure.

In SSIS, you can use the **Execute SQL Task** to call the SF\_TableLoader stored procedure. The connection manager for the task should be a connection to the SQL Server (NOT the DBAmp OLE DB provider). The SQL Source Type should be Direct Input and the SQL Statement should be the call to the SF\_TableLoader stored procedure.

The **Execute SQL Task** that contains the SF\_TableLoader call normally has 2 precedence constraints: 1 for SUCCESS and 1 for FAIL.

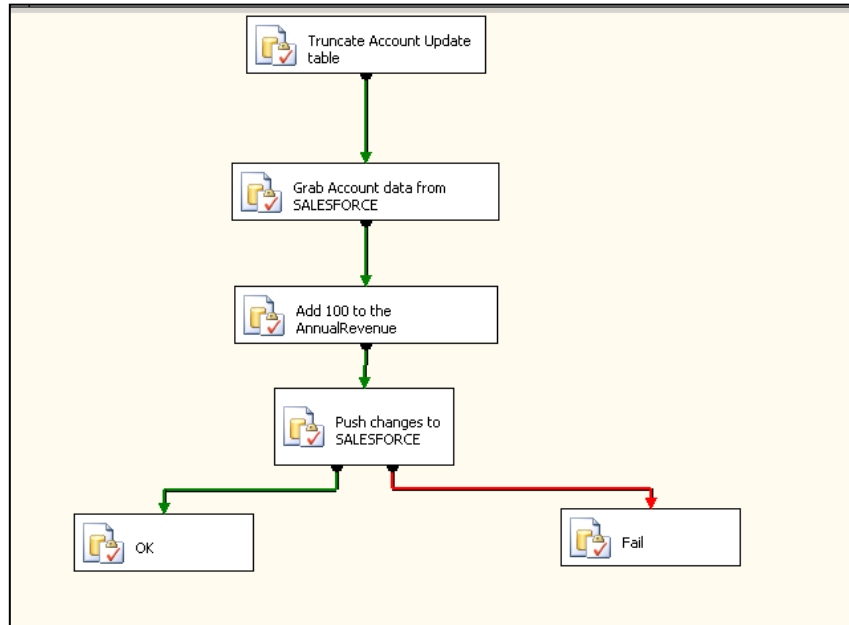

You can use the Precedence Constraints to direct flow based on the SF\_TableLoader outcome. SF\_TableLoader (and therefore the **Execute SQL Task**) fails if any row of the table cannot be processed successfully. If only a partial number of rows succeed, the FAIL precedence constraint fires. When this occurs, you can identify the successful rows by using the following SQL:

```
Select * from Account_SSISUpdate_Result  
where Error like '%Operation Successful%'
```



## Chapter 6: Uploading files into Content, Documents and Attachments

You can use DBAmp to upload files into salesforce.com as Content, Documents or Attachments with the SF\_TableLoader stored procedure. When you place a file path in the VersionData or Body column, SF\_TableLoader will use the path to obtain the data needed.

SALESFORCE guidelines for uploading documents in ContentVersion object:

“To create a document, create a new version via the ContentVersion object without setting the ContentDocumentId. This automatically creates a parent document record. When adding a new version of the document, you must specify an existing ContentDocumentId which initiates the revision process for the document. When the latest version is published, the title, owner, and publish status fields are updated in the document.”

To upload Content, use the following steps:

1. Use the SF\_Generate stored procedure to generate a table to be used for the upload. See SF\_Generate in the Stored Procedure reference for more details on SF\_Generate.

```
exec sf_generate 'Insert','SALESFORCE','ContentVersion_Load'
```

2. Using SQL, modify the VersionData column type to be a nvarchar(500) instead of an image type.

```
Alter table ContentVersion_Load Drop Column VersionData
```

```
Alter table ContentVersion_Load Add VersionData nvarchar(500) null
```

3. Insert rows into ContentVersion\_Load with the following values:

- Title - file name.
- ContentDocumentId – ID of the document.
- Origin -The source of the content version. Valid values are:
  - C—This is a Content document from the user's personal library. Label is Content. The FirstPublishLocationId must be the user's ID. If FirstPublishLocationId is left blank, it defaults to the user's ID.
  - H—This is a Chatter file from the user's My Files. Label is Chatter. The FirstPublishLocationId must be the user's ID. If FirstPublishLocationId is left blank, it defaults to the user's ID. Origin can only be set to H if Chatter is enabled for your organization.

This field defaults to C. Label is Content Origin.

- OwnerId - ID of the owner of this document.
  - Description - (optional) file or link description.
  - VersionData - complete file path on the local drive of the file you want to upload to Salesforce. For example:  
c:\serialnumber.txt
  - PathOnClient - complete file path on the local drive of the file you want to upload to Salesforce.
  - ContentUrl - URL (for uploading links only, leave blank for files).
  - FirstPublishLocationId - workspace ID.
  - RecordTypeId - content type ID. If you publish to a workspace that has restricted content types, you must specify RecordTypeId.
4. Upload the table to Salesforce.com with SF\_TableLoader. SF\_TableLoader will automatically read the file using the location found in the VersionData column and pass the contents to Salesforce as the file.

Note: You cannot use the bulkapi switch when uploading content with SF\_TableLoader.

```
exec SF_TableLoader 'Insert','SALESFORCE','ContentVersion_Load'
```

5. Check the Error column of ContentVersion\_Load\_Result table for any error messages that may have occurred during the upload.

To upload Attachments, use the following steps:

1. Use the SF\_Generate stored procedure to generate a table to be used for the upload. See SF\_Generate in the Stored Procedure reference for more details on SF\_Generate.

```
exec sf_generate 'Insert','SALESFORCE','Attachment_Load'
```

2. Using SQL, modify the Body column type to be a nvarchar(500) instead of an image type.

```
Alter table Attachment_Load Drop column Body
```

```
Alter table Attachment_Load Add Body nvarchar(500) null
```

3. Insert rows into Attachment\_Load with the following values:
  - Name - file name.

- Description - (optional) file description.
- Body- complete file path on the local drive of the computer where DBAmp is installed. For example: c:\serialnumber.txt
- IsPrivate - false/true
- OwnerId - (optional) file owner, defaults to the user uploading the file.
- ParentId – ID of the parent object of the attachment. The following objects are supported as parents of attachments:

Account, Asset, Campaign, Case, Contact, Contract, Custom objects, EmailMessage, EmailTemplate, Event, Lead, Opportunity, Product2, Solution, Task.

4. Upload the table to Salesforce.com with SF\_TableLoader. SF\_TableLoader will automatically read the file using the location found in the Body column and pass the contents to salesforce as the file.

Note: You cannot use the bulkapi switch when uploading attachments with SF\_TableLoader.

```
exec SF_TableLoader 'Insert','SALESFORCE','Attachment_Load'
```

5. Check the Error column of Attachment\_Load\_Result table for any error messages that may have occurred during the upload.

### **Using BlobId Option to push Blob Ids with SF TableLoader**

The **RestAPI** of Salesforce allows you to push binary blobs **larger** than 20 MB. The **BlobId** option allows you to specify blob Ids to push to Salesforce using the **RestAPI**. This option can only be used with the **Update** and **Insert** operations, and can only be used with three objects: **ContentVersion, Attachment, and Document.**

When the **BlobId** option is specified, SF\_TableLoader will look at the Id column of the input table and try to match each Id value with a binary blob files that exist in the Blob Directory. The Blob Directory is specified on the Options page of the DBAmp Configuration Program on the server. The binary blob files that exist in the Blob Directory are brought down by the SF\_DownloadBlobs stored procedure. For more information on SF\_DownloadBlobs, see the **SF\_DownloadBlobs section in this Chapter.**

The following are the steps to follow to push binary blobs to Salesforce:

1. Use SF\_DownloadBlobs to download the binary blob files to the Blob Directory that are to be pushed up to Salesforce. See the SF\_DownloadBlobs section in this Chapter for more information.

2. Create the input table that will contain the records to push to Salesforce.
3. Populate the input table with the records to push to Salesforce. The Id values need to be the Salesforce Id of the record to push. **Note:** This Id needs to match the Id prefix of a binary blob file in the Blob Directory. If there is not a binary blob file in the Blob Directory that matches an Id specified in the input table, SF\_TableLoader will throw an error for that record in the Result table.
4. Use SF\_TableLoader with the BlobId option to push the binary blobs to Salesforce. For example:

```
exec SF_TableLoader 'Insert:blobid', 'SALESFORCE', 'ContentVersion_Load'
```

5. Check the Result table for any errors that may have occurred. The Result table name is the input table name with \_Result appended to the end. For example: ContentVersion\_Load\_Result.

Below is an example of using the BlobId option with SF\_TableLoader to insert a ContentVersion binary blob to Salesforce using the RestAPI:

1. Create input table to supply to SF\_DownloadBlobs:

**Create Table ContentVersion\_Blobs**

**(Id nchar(18))**

2. Insert ContentVersion record Id of binary blob to insert into Salesforce:

**Insert Into ContentVersion\_Blobs (Id)**

**Values ('0683A000006HINuQAO')**

3. Run SF\_DownloadBlobs to bring down the binary blob file into the Blob Directory for the ContentVersion record Id supplied in the input table:

```
exec SF_DownloadBlobs 'SALESFORCE', 'ContentVersion_Blobs'
```

4. Create input table to supply to SF\_TableLoader:

**Create Table ContentVersion\_Load**

**(Id nchar(18),**

**ContentDocumentId nchar(18),**

**Title nvarchar(255),**

**PathOnClient nvarchar(500))**

5. Populate input table with blob record you want to insert into Salesforce:

**Insert Into ContentVersion\_Load (Id, ContentDocumentId, Title,  
PathOnClient)**

**Values ('0683A000006HINuQAO', '0694S000001dfmiQAA', 'Test',  
'attachexample.txt')**

6. Run SF\_TableLoader with the BlobId option to insert the blob record into Salesforce:

**exec SF\_TableLoader 'Insert:blobid', 'SALESFORCE',  
'ContentVersion\_Load'**

7. Check the ContentVersion\_Load\_Result table for the Salesforce Id of the newly inserted record and any errors that may have occurred:

**Select Id, Error from ContentVersion\_Load\_Result**

## Chapter 7: DBAmp Stored Procedure Reference

**Note:** the `SF_ReplicateTemporal`, `SF_RefreshTemporal`, `SF_BulkSOQLTemporal`, and `SF_BulkSOQL_RefreshTemporal` stored procedures have been deprecated. Use `SF_Mirror` with the temporal option instead. See the `SF_Mirror` section in this chapter for more information.

### SF\_BulkOps

**Note:** Consider using `SF_TableLoader` instead of `SF_BulkOps`. `SF_TableLoader` performs much better than `SF_BulkOps`.

#### Usage

`SF_BulkOps` takes as input a local SQL Server table you create that is designated as the "input" table. The input table name must begin with a valid Salesforce object name followed by an underscore and suffix. For example, `Account_Load` and `Account_FromWeb` are valid input table names. `XXX_Load` is not a valid input table name (`XXX` is not a valid Salesforce.com object).

The input table must contain a column named `Id` defined as `nchar(18)` and a column named `Error` defined as `nvarchar(255)`. In addition, the input table can contain other columns that match the fields of the Salesforce object. `SF_BulkOps` produces warning messages for all columns that do not match a field in the salesforce.com object. Non-matching columns are not considered an error because you may want to have column data in the table for reference but that should be intentionally ignored.

**Do not allow other applications to write to the input table while `sf_bulkops` is running.**

**NOTE:** There are two different API's available from salesforce.com that applications can use to push data: the Web Services API or the Bulk API. You can use either API with `SF_BulkOps` with the Web Services API being the default.

The Web Services API is synchronous, meaning that for every 200 rows that are sent to salesforce, an immediate response is sent indicating the success or failure of those 200 rows. `SF_BulkOps` has traditionally used the Web Services API. The disadvantage of this API is that the maximum number of rows that can be sent to salesforce at a time is 200. So if the input table to `SF_BulkOps` contains 1000 rows, there will be at least 5 API calls to send the data to the salesforce.com server.

The Bulk API is asynchronous, meaning that rows sent to salesforce.com are queued as a job. The job is executed at some time in the future. The advantage of the Bulk API is that up to 10,000 rows can be sent in a single request or API call. An input table of 5000 rows would require a single API

call to send the data, along with API calls to retrieve the status at some point in the future.

By default, SF\_BulkOps uses the Web Services API.

The **SF\_Generate** stored procedure can be used to quickly build input tables for **SF\_BulkOps**.

The **SF\_ColCompare** stored procedure can be used to compare 'hand built' tables against the salesforce.com object to ensure correct column names.

**SF\_BulkOps** can perform one of thirteen operations:

1. **Insert** – When the operation requested is **Insert**, the **SF\_BulkOps** reads each row of the input table, matches the columns to the fields of the Salesforce object, and attempts to insert the new object into Salesforce. **Important: SF\_BulkOps** attempts to insert all rows of the load table regardless of any existing values in the Id and Error columns.
2. **Insert:BulkAPI** – Insert rows from the table using the Bulk API instead of the Web Services API.
3. **Upsert** - When the operation requested is **Upsert**, the **SF\_BulkOps** reads each row of the input table, matches the columns to the fields of the Salesforce object, and attempts to upsert the new object into Salesforce using the specified external id field. **Important: SF\_BulkOps** attempts to upsert all rows of the load table regardless of any existing values in the Id and Error columns.
4. **Upsert:BulkAPI** – Upsert row using the Bulk API instead of the Web Services API.
5. **Update** – When the operation requested is **Update**, the **SF\_BulkOps** reads each row of the input table, maps the columns to the fields of the Salesforce object, and attempts to update an object in Salesforce using the Id column of the input table.

Important: the input table should only contain columns for those fields that you want to update. If the data in a column is an empty string or NULL, sf\_bulkops will update that field on salesforce.com to be NULL. You may modify this behavior by using the following value for the operation: Update:IgnoreNulls . The IgnoreNulls option tells sf\_bulkops to ignore null values in columns. However, empty string values will still set the field on salesforce.com to NULL.

6. **Update:BulkAPI** – Update salesforce objects using the Bulk API instead of the Web Services API.
7. **Delete** - When the operation requested is **Delete**, the **SF\_BulkOps** reads each row of the input table and uses the Id field to delete an object in Salesforce.

8. **Delete: BulkAPI** – Delete objects in salesforce using the Bulk API instead of the Web Services API.
9. **HardDelete: BulkAPI** – Delete objects in salesforce using the Bulk API. In addition, the deleted records are not stored in the Recycle Bin.
10. **Status** – Populate the Error column with the current job/batch status. This is used when using BulkAPI operations to determine the result of the operation.
11. **ConvertLead** – Converts Lead records.
12. **UnDelete** – Use this option to undelete rows from the Recycle bin. You can identify deleted rows using a query against the \_QueryAll table:

```
Select Id from SALESFORCE...Account_QueryAll
where IsDeleted= 'True '
```

13. **IgnoreFailures** – Use this option to specify the percent of records in a BulkOps input table to allow to fail, without failing the BulkOps job.

For each row in the input table that the operation fails, the Error column will contain the error message for the failure.

### **Syntax**

```
exec SF_BulkOps 'Insert', 'linked_server', 'object', 'OptionalSoapHdr'
```

Or

```
exec SF_BulkOps 'Delete', 'linked_server', 'object', 'OptionalSoapHdr'
```

Or

```
exec SF_BulkOps 'Update: BulkAPI', 'linked_server', 'object', 'OptionalSoapHdr'
```

or

```
exec SF_BulkOps 'Upsert', 'linked_server', 'object', 'eid', , 'OptionalSoapHdr'
```

where *linked\_server* is the name of your linked server , *object* is the name of the object, and *eid* is the name of the external id field.

The *OptionalSoapHdr* parameter is optional and may be used to pass salesforce.com SOAP headers for this execution only. See *Using Optional SOAP Headers* later in this section.

### **Example**



The following example bulk inserts rows from the local table named Account\_Load into the Account object at Salesforce.com using the SALESFORCE linked server.

```
exec sf_bulkops 'Insert', 'SALESFORCE', 'Account_Load'
```

### **Controlling the batch size**

SF\_BulkOps uses a batch size of 200 rows (Web Services API) or 5,000 (Bulk API). You may need to reduce the batch size to accommodate APEX code on the salesforce.com server. To specify a different batch size, use the batchsize(xx) option after the operation.

For example, to set the batch size to 50:

```
Exec SF_Bulkops 'Update:batchsize(50)', 'Salesforce', 'User_Upd'
```

If you are also using the IgnoreNulls option, then separate the options with a comma:

```
Exec sf_bulkops 'Update:IgnoreNulls,batchsize(50)', 'Salesforce', 'User_Upd'
```

### **Controlling the Concurrency Mode**

If you are using the bulkapi switch, the default concurrency mode is Serial. To specify parallel concurrency mode instead, use the parallel option:

```
Exec SF_Bulkops 'Update:bulkapi,parallel', 'Salesforce', 'User_Upd'
```

### **Skipping the Status check**

If you prefer not to have DBAmp poll for the status (i.e. "fire and forget") then add the phrase (ns) after the bulkapi option: **'Insert:bulkapi(ns)'**

### **Using Optional SOAP Headers**

The salesforce api allow you to pass additional SOAP Headers that alter the behavior of the sf\_bulkops operation. The SOAP Headers are described in detail in the salesforce.com api documentation:

[http://www.salesforce.com/us/developer/docs/api/Content/soap\\_headers.htm](http://www.salesforce.com/us/developer/docs/api/Content/soap_headers.htm)

The headers are specified in the form of 3 values separated by commas. The first value is the header name, the next value is the section name and the last value is the value for the section. The entire parameter is enclosed in quotes. The salesforce.com api is case sensitive with respect to these values; use the exact token given in the salesforce.com documentation.

For example, to use the default assignment rule for these inserted Leads you would add the following SOAP Header parameter:

```
exec sf_bulkops 'Insert', 'SALESFORCE', 'Lead_Test', 'AssignmentRuleHeader,useDefaultRule,true'
```

The DBAmp Registry settings can also be used to add SOAP headers. The difference is the SOAP header parameter on the sf\_bulkops call is a "one-time" use. The DBAmp Registry settings apply the SOAP header to all

operations of DBAmp. Therefore, using the SOAP header parameter allows a finer control over the header usage.

Here are some other examples of SOAP headers:

Trigger auto-response rules for leads and cases: `'EmailHeader,triggerAutoResponseEmail,true'`

Changes made are not tracked in feeds: `'DisableFeedTrackingHeader,disableFeedTracking,true'`

SOAP Headers cannot be used along with the bulkapi switch.

### **Using IgnoreFailures Option**

Used to specify the percent of records in the input table to allow to fail, without failing the BulkOps job. Use the following command to allow up to 20 percent of the records in the Opportunity\_Load to fail, without the BulkOps job failing:

**Exec SF\_BulkOps 'Insert:IgnoreFailures(20)', 'SALESFORCE', 'Opportunity\_Load'**

Note: IgnoreFailures option can be used with the BulkAPI switch of SF\_BulkOps.

### **Notes**

When individual rows of the input table fail to complete the operation, sf\_bulkops writes the error message back to the Error column of that row and continues processing the next row. Thus, in a batch of 200 rows it is possible that 175 rows were successful and 25 rows failed.

The sf\_bulkops stored procedure outputs an error message in the log indicating the sf\_bulkops failed when 1 or more rows failed. The correct interpretation of this error message is that at least 1 row of the input table contained an error. In addition, sf\_bulkops outputs messages indicating the total number of rows processed the number of rows that failed and the number of rows that succeeded.

For all rows that were successfully processed, sf\_bulkops writes the phrase "Operation Successful" to the Error column. Successfully processed rows can therefore be selected using the following SQL Select:

```
Select * from Account_Load where Error like '%Operation Successful%'
```

This technique works for the bulkapi switch as well.

If sf\_bulkops is run in a job step, then the job step will fail if one or more rows contain an error. Again, the rows that contain a blank error message were still successful; the failure is thrown to indicate to the operator that at least one row failed.

## SF\_TableLoader

### Usage

**SF\_TableLoader** takes as input a local SQL Server table you create that is designated as the "input" table. The input table name must begin with a valid Salesforce object name followed by an underscore and suffix. For example, **Account\_Load** and **Account\_FromWeb** are valid input table names. **XXX\_Load** is not a valid input table name (XXX is not a valid Salesforce.com object).

The input table must contain a column named **Id** defined as nchar(18). An Error column is not required in the input table. **SF\_TableLoader** handles the Error column for you. The results are written to a Result table, instead of back to the input table. The Result table is named: Input table + **\_Result**. For example, if the input table was named **Account\_Load**, the Result table will be named **Account\_Load\_Result**.

In addition, the input table can contain other columns that match the fields of the Salesforce object. **SF\_TableLoader** produces warning messages for all columns that do not match a field in the salesforce.com object. Non-matching columns are not considered an error because you may want to have column data in the table for reference but that should be intentionally ignored. When using the **BulkAPI2**, the Result table only contains the columns sent to Salesforce, all ignored columns are not included in the Result table. When using the **SOAP API** or **BulkAPI**, all columns in the input table are included in the Result table.

**Do not allow other applications to write to the input table while SF\_TableLoader is running.**

**NOTE:** There are three different API's available from Salesforce.com that **SF\_TableLoader** can use to push data: the **SOAP API**, the **BulkAPI**, and the **BulkAPI2 API**. **SF\_TableLoader** automatically determines which API to use that provides the best performance based on the input table.

The SOAP API is synchronous, meaning that for every 200 rows that are sent to salesforce, an immediate response is sent indicating the success or failure of those 200 rows. The disadvantage of this API is that the maximum number of rows that can be sent to salesforce at a time is 200. So, if the input table to **SF\_TableLoader** contains 1000 rows, there will be at least 5 API calls to send the data to the salesforce.com server.

The BulkAPI is asynchronous, meaning that rows sent to Salesforce.com are queued as a job. The job is executed at some time in the future. The application must enquire about the status of the job at a later time to retrieve the success, failure, or unprocessed results of the rows sent.

The BulkAPI2 API is asynchronous, meaning that rows sent to Salesforce.com are queued as a job. The job is executed at some time in the future. The application must enquire about the status of the job at a

later time to retrieve the success, failure, or unprocessed results of the rows sent. The advantage of the bulkapi2 is that Salesforce handles the batching and concurrency for you.

By default, **SF\_TableLoader** automatically determines which API to use that provides the best performance based on the input table.

The **SF\_Generate** stored procedure can be used to quickly build input tables for **SF\_TableLoader**.

The **SF\_ColCompare** stored procedure can be used to compare 'hand built' tables against the salesforce.com object to ensure correct column names.

**SF\_TableLoader** can perform one of 7 operations:

1. **Insert** – When the operation requested is **Insert**, **SF\_TableLoader** reads each row of the input table, matches the columns to the fields of the Salesforce object, and attempts to insert the new object into Salesforce. **Important: SF\_TableLoader** attempts to insert all rows of the load table regardless of any existing values in the Id and Error columns.
2. **Upsert** - When the operation requested is **Upsert**, **SF\_TableLoader** reads each row of the input table, matches the columns to the fields of the Salesforce object, and attempts to upsert the new object into Salesforce using the specified external id field. **Important: SF\_TableLoader** attempts to upsert all rows of the load table regardless of any existing values in the Id and Error columns.
3. **Update** – When the operation requested is **Update**, **SF\_TableLoader** reads each row of the input table, maps the columns to the fields of the Salesforce object, and attempts to update an object in Salesforce using the Id column of the input table.

Important: the input table should only contain columns for those fields that you want to update. If the data in a column is an empty string or NULL, **SF\_TableLoader** will update that field on salesforce.com to be NULL. You may modify this behavior by using the following value for the operation: Update:IgnoreNulls. The IgnoreNulls option tells **SF\_TableLoader** to ignore null values in columns. However, empty string values will still set the field on salesforce.com to NULL.

4. **Delete** - When the operation requested is **Delete**, **SF\_TableLoader** reads each row of the input table and uses the Id field to delete an object in Salesforce.
5. **HardDelete** - When the operation requested is **HardDelete**, **SF\_TableLoader** reads each row of the input table and uses the Id field to harddelete an object in Salesforce.

6. **ConvertLead** – Converts Lead records. See **Converting Leads with SF TableLoader** in Chapter 4 for more details.
7. **UnDelete** – Use this option to undelete rows from the Recycle bin. You can identify deleted rows using a query against the `_QueryAll` table:

```
Select Id from SALESFORCE...Account_QueryAll
where IsDeleted= 'True'
```

### **Syntax**

```
exec SF_TableLoader 'Insert', 'linked_server', 'object', 'OptionalSoapHdr'
```

Or

```
exec SF_TableLoader 'Delete', 'linked_server', 'object', 'OptionalSoapHdr'
```

Or

```
exec SF_TableLoader 'Update', 'linked_server', 'object', 'OptionalSoapHdr'
```

or

```
exec SF_TableLoader 'Upsert', 'linked_server', 'object', 'eid', 'OptionalSoapHdr'
```

where *linked\_server* is the name of your linked server, *object* is the name of the object, and *eid* is the name of the external id field.

The *OptionalSoapHdr* parameter is optional and may be used to pass salesforce.com SOAP headers for this execution only. See *Using Optional SOAP Headers* later in this section. **Note:** this parameter can only be used with the **soap** switch.

### **Example**

The following example bulk inserts rows from the local table named `Account_Load` into the `Account` object at `Salesforce.com` using the `SALESFORCE` linked server.

```
exec SF_TableLoader 'Insert', 'SALESFORCE', 'Account_Load'
```

### **Using the SF TableLoader switches**

There are three switches that can be used to force `SF_TableLoader` to use a certain Salesforce API:

- `soap` – this switch forces `SF_TableLoader` to use the **SOAP API**.
- `bulkapi` – this switch forces `SF_TableLoader` to use the **BulkAPI**.
- `bulkapi2` – this switch forces `SF_TableLoader` to use the **BulkAPI2**.

By default, if the number of rows in the input table is less than 5,000, `SF_TableLoader` will use the SOAP API. If the number of rows in the input table is greater than 5,000, `SF_TableLoader` will use the BulkAPI. The

bulkapi2 switch needs to be specified for SF\_TableLoader to use the BulkAPI2 API.

For example, to force SF\_TableLoader to use the BulkAPI2 API:

```
Exec SF_TableLoader 'Update:bulkapi2','Salesforce','User_Upd'
```

### **Controlling the batch size**

**SF\_TableLoader** with the soap switch uses a default batch size of 200 rows (SOAP API). When using the bulkapi, SF\_TableLoader uses a default batch size of 10,000. You may need to reduce the batch size to accommodate APEX code on the salesforce.com server. To specify a different batch size, use the batchsize(xx) option after the operation.

**Note:** The **batchsize** option **cannot** be used when using the **bulkapi2** switch.

For example, to set the batch size to 50:

```
Exec SF_TableLoader 'Update:soap,batchsize(50)','Salesforce','User_Upd'
```

If you are also using the IgnoreNulls option, then separate the options with a comma:

```
Exec sf_tableLoader 'Update:IgnoreNulls,batchsize(50)','Salesforce','User_Upd'
```

### **Controlling the Concurrency Mode**

If you are using the bulkapi switch, the default concurrency mode is Parallel. To specify serial concurrency mode instead, use the serial option:

```
Exec SF_TableLoader 'Update:bulkapi,serial','Salesforce','User_Upd'
```

**Note:** The concurrency mode **cannot** be specified if using the soap or bulkapi2 switches.

### **Using Optional SOAP Headers**

The SOAP API allows you to pass additional SOAP Headers that alter the behavior of the **SF\_TableLoader** operation. The **soap** switch must be provided to use the optional SOAP Headers. The SOAP Headers are described in detail in the Salesforce.com API documentation: [http://www.salesforce.com/us/developer/docs/api/Content/soap\\_headers.htm](http://www.salesforce.com/us/developer/docs/api/Content/soap_headers.htm)

The headers are specified in the form of 3 values separated by commas. The first value is the header name, the next value is the section name and the last value is the value for the section. The entire parameter is enclosed in quotes. If you are specifying multiple SOAP Headers, separate them with a semicolon. The salesforce.com API is case sensitive with respect to these values; use the exact token given in the Salesforce.com documentation.

For example, to use the default assignment rule for these inserted Leads you would add the following SOAP Header parameter:

```
Exec SF_TableLoader
'Insert:soap','SALESFORCE','Lead_Test','AssignmentRuleHeader,useDefaultRule,true'
```

The DBAmp Registry settings can also be used to add SOAP headers. The difference is the SOAP header parameter on the **SF\_TableLoader** call is a “one-time” use. The DBAmp Registry settings apply the SOAP header to all operations of DBAmp. Therefore, using the SOAP header parameter allows a finer control over the header usage.

Here are some other examples of SOAP headers:

Trigger auto-response rules for leads and cases: 'EmailHeader,triggerAutoResponseEmail,true'  
Changes made are not tracked in feeds: 'DisableFeedTrackingHeader,disableFeedTracking,true'

Note: SOAP Headers can only be used with the **soap** switch of **SF\_TableLoader**.

### **Using AssignmentRuleId Option with SF TableLoader**

The BulkAPI allows you to pass an AssignmentRuleId that specifies who the owner of a Case or Lead is. The AssignmentRuleId option can only be used with the **BulkAPI** and if the data is being pushed to either the **Case** or **Lead** objects.

Query the AssignmentRule table to obtain the AssignmentRuleId that is to be used to specify the owner of the Case or Lead:

```
Select * from SALESFORCE...AssignmentRule
```

Where SALESFORCE is the name of your linked server.

The AssignmentRuleId option is passed after the operation in the SF\_TableLoader command. To specify an AssignmentRuleId, use the assignmentruleid(xx) option after the operation:

```
exec SF_TableLoader 'update:bulkapi,assignmentruleid(01Q300000001Tp5EAE)',
'SALESFORCE', 'Lead_Update'
```

**Note:** The AssignmentRuleId option can only be used with the **BulkAPI**. Therefore, if the input table contains **less** than 5,000 rows, the **bulkapi** option **must** also be specified after the operation. If the input table contains **more** than 5,000 rows, the **bulkapi** option **does not** have to be specified after the operation.

The BulkAPI is case sensitive with respect to the AssignmentRuleId value; use the exact AssignmentRuleId given in the AssignmentRule table.

**Note:** only **one** AssignmentRuleId can be given in the command.

### **Using IgnoreFailures Option**

Used to specify the percent of records in the input table to allow to fail, without failing the TableLoader job. Use the following command to allow up

to 20 percent of the records in the Opportunity\_Load to fail, without the TableLoader job failing:

```
Exec SF_TableLoader 'Insert:IgnoreFailures(20)', 'SALESFORCE',  
'Opportunity_Load'
```

Note: IgnoreFailures option can be used with all three switches of **SF\_TableLoader**.

### **Using BlobId Option to push Blob Ids with SF\_TableLoader**

The **RestAPI** of Salesforce allows you to push binary blobs **larger** than 20 MB. The **BlobId** option allows you to specify blob Ids to push to Salesforce using the **RestAPI**. This option can only be used with the **Update** and **Insert** operations, and can only be used with three objects: **ContentVersion**, **Attachment**, and **Document**.

When the **BlobId** option is specified, SF\_TableLoader will look at the Id column of the input table and try to match each Id value with a binary blob files that exist in the Blob Directory. The Blob Directory is specified on the Options page of the DBAmp Configuration Program on the server. The binary blob files that exist in the Blob Directory are brought down by the SF\_DownloadBlobs stored procedure. For more information on SF\_DownloadBlobs, see the **SF\_DownloadBlobs section in this Chapter**.

The following are the steps to follow to push binary blobs to Salesforce:

1. Use SF\_DownloadBlobs to download the binary blob files to the Blob Directory that are to be pushed up to Salesforce. See the SF\_DownloadBlobs section in this Chapter for more information.
2. Create the input table that will contain the records to push to Salesforce.
3. Populate the input table with the records to push to Salesforce. The Id values need to be the Salesforce Id of the record to push. **Note:** This Id needs to match the Id prefix of a binary blob file in the Blob Directory. If there is not a binary blob file in the Blob Directory that matches an Id specified in the input table, SF\_TableLoader will throw an error for that record in the Result table.
4. Use SF\_TableLoader with the BlobId option to push the binary blobs to Salesforce. For example:

```
exec SF_TableLoader 'Insert:blobid', 'SALESFORCE', 'ContentVersion_Load'
```

5. Check the Result table for any errors that may have occurred. The Result table name is the input table name with \_Result appended to the end. For example: ContentVersion\_Load\_Result.

Below is an example of using the BlobId option with SF\_TableLoader to insert a ContentVersion binary blob to Salesforce using the RestAPI:



1. Create input table to supply to SF\_DownloadBlobs:

**Create Table ContentVersion\_Blobs**

**(Id nchar(18))**

2. Insert ContentVersion record Id of binary blob to insert into Salesforce:

**Insert Into ContentVersion\_Blobs (Id)**

**Values ('0683A000006HINuQAO')**

3. Run SF\_DownloadBlobs to bring down the binary blob file into the Blob Directory for the ContentVersion record Id supplied in the input table:

**exec SF\_DownloadBlobs 'SALESFORCE', 'ContentVersion\_Blobs'**

4. Create input table to supply to SF\_TableLoader:

**Create Table ContentVersion\_Load**

**(Id nchar(18),**

**ContentDocumentId nchar(18),**

**Title nvarchar(255),**

**PathOnClient nvarchar(500))**

5. Populate input table with blob record you want to insert into Salesforce:

**Insert Into ContentVersion\_Load (Id, ContentDocumentId, Title, PathOnClient)**

**Values ('0683A000006HINuQAO', '0694S000001dfmiQAA', 'Test', 'attachexample.txt')**

6. Run SF\_TableLoader with the BlobId option to insert the blob record into Salesforce:

**exec SF\_TableLoader 'Insert:blobid', 'SALESFORCE', 'ContentVersion\_Load'**

7. Check the ContentVersion\_Load\_Result table for the Salesforce Id of the newly inserted record and any errors that may have occurred:

**Select Id, Error from ContentVersion\_Load\_Result**

**Notes**

A full explanation of the **SF\_TableLoader** stored procedure can be found in *Chapter 4: Bulk Insert, Upsert, Delete and Update into Salesforce using SF\_TableLoader*.

When individual rows of the input table fail to complete the operation, **SF\_TableLoader** writes the error message back to the Error column in the Result table. Thus, in a batch of 200 rows it is possible that 175 rows were successful and 25 rows failed.

The **SF\_TableLoader** stored procedure outputs an error message in the log indicating the **SF\_TableLoader** failed when 1 or more rows failed. The correct interpretation of this error message is that at least 1 row of the Result table contained an error. In addition, **SF\_TableLoader** outputs messages indicating the total number of rows processed, the number of rows that failed, the number of rows that succeeded, and the number of rows unprocessed.

For all rows that were successfully processed, **SF\_TableLoader** writes the phrase 'Operation Successful' to the Error column in the Result table. Successfully processed rows can therefore be selected using the following SQL Select:

```
Select * from Account_Load_Result where Error like '%Operation Successful%'
```

If **SF\_TableLoader** is run in a job step, then the job step will fail if one or more rows contain an error. Again, the rows that contain a blank error message were unprocessed by Salesforce; the failure is thrown to indicate to the operator that at least one row failed.

# SF\_BulkSOQL

## Usage

**SF\_BulkSOQL** creates and populates a local SQL table with the results of a SOQL query. **SF\_BulkSOQL uses the salesforce Bulk API**. Therefore, the SOQL query must be valid to use with the Bulk API. For more information on SOQL that is valid with the Bulk API, visit this link: [https://developer.salesforce.com/docs/atlas.en-us.api\\_async.meta/api\\_async/asynch\\_api\\_using\\_bulk\\_query.htm](https://developer.salesforce.com/docs/atlas.en-us.api_async.meta/api_async/asynch_api_using_bulk_query.htm)

SF\_BulkSOQL functionality uses two SQL Server tables: a **Results table** and a **SOQL table**. The following goes into detail on each table:

### 1. Results Table

- Holds the results of a SOQL statement in a SQL Server table locally
- Table is created or recreated when the SF\_BulkSOQL stored procedure runs
- Provided in the 2<sup>nd</sup> parameter of the SF\_BulkSOQL stored procedure
- The name of the table cannot be the name of a valid Salesforce object. (AccountsContacts is valid, Contact is not valid)
- The name of the table should describe the results of the SOQL statement (Ex.- A SOQL statement that is bringing down Accounts and Contacts could be named AccountsContacts)

### 2. SOQL Table

- Holds the SOQL statement that populates the Results table
- Must be named: Results table name + an underscore + "SOQL" (Ex.- AccountsContacts\_SOQL)
- Must be created prior to running the SF\_BulkSOQL stored procedure
- Must contain one column only, named "SOQL" defined nvarchar(max). Example:

```
Create Table AccountsContacts_SOQL  
(SOQL nvarchar(max))
```

- Must contain one row only

- Value of one row in the SOQL field must be a valid BulkAPI SOQL statement

**Do not allow other applications to write to the same Results table or the SOQL table while SF\_BulkSOQL is running.**

### **Syntax**

```
exec SF_BulkSOQL 'table_server', 'table_name', 'options',
'soql_statement'
```

where *table\_server* is the name of your linked server and *table\_name* is the name of the Results table. There are several optional options you may include as well. Where *soql\_statement* is the SOQL statement that can be passed in as a 4<sup>th</sup> parameter. If you pass in a SOQL statement via the 4<sup>th</sup> parameter, you do not have to create a SOQL table, SF\_BulkSOQL creates it.

### **Example**

The following example creates a local AccountsContacts Results table.

1. Create the SOQL table:

**Create Table AccountsContacts\_SOQL**

**(SOQL nvarchar(max))**

2. Insert the SOQL statement into the SOQL column of the SOQL table:

**Insert Into AccountsContacts\_SOQL (SOQL)**

**Values('Select Account.Id, Account.Name, \* from Contact')**

3. Run the SF\_BulkSOQL stored procedure to populate the Results table:

```
exec SF_BulkSOQL 'SALESFORCE', 'AccountsContacts'
```

Notice the Results table in the 2<sup>nd</sup> parameter of the SF\_BulkSOQL stored procedure.

### **How to run the SF BulkSOQL proc without using xp\_cmdshell**

**Step 1: Run the SF\_BulkSOQLPrep stored procedure with the same parameters used for SF\_BulkSOQL.** Replace the SF\_BulkSOQL stored procedure with the SF\_BulkSOQLPrep stored procedure using the same parameters in the example above. If passing in the SOQL Statement to the SF\_BulkSOQLPrep stored procedure follow the example below, **Example passing in SOQL statement**, but replace SF\_BulkSOQL with SF\_BulkSOQLPrep. **Note:** you must use the SF\_BulkSOQLPrep stored procedure if you are not using xp\_cmdshell.

**Step 2: Run the underlying BulkSOQL program directly (i.e. instead of using the SF\_BulkSOQL stored procedure) using CmdExec.** The name of the exe is DBAmpNet2.exe and it is located in the DBAmp Program Files directory. Normally the directory is c:\Program Files\DBAmp but DBAmp may be installed in a different location.

The DBAmpNet2.exe program takes the following 7 parameters:

1. **Command:** Must be **Export**.
2. **Operation:** must be **Replicate:bulksoql**.
3. **Result table:** the name of the result table. Must be the name of the created SOQL table, but instead of **\_SOQL** on the end, it is **\_Result**. For example, if the SOQL table you created is **AccountsContacts\_SOQL**, then the result table must be **AccountsContacts\_Result**.
4. **SQL Server Name:** The name of the SQL instance to connect to.
5. **SQL Database Name:** The name of the database to connect to. Enclose in double quotes if the name contains a blank.
6. **Link Server Name:** The name of the DBAmp link server.
7. **Base table:** the name of the base table. Must be the name of the created SOQL table, minus the **\_SOQL**. For example, if the SOQL table you created is **AccountsContacts\_SOQL**, then the result table must be **AccountsContacts**.

Here is an example of a complete command:

```
"C:\Program Files\DBAmp\DBAmpNet2.exe" Export Replicate:bulksoql  
AccountsContacts_Result BUDDY "ReplicateAll Testing" SALESFORCE  
AccountsContacts
```

Note that even though the command appears on multiple lines in this document, the command must be entered as a single line in the job step. Also notice the use of double quotes around both the program and the database. This is required because those values contain blanks.

When setting up a job step to call the program directly, you must change the **Type** of the job step to: **Operating System (CmdExec)**. Then enter your complete command in the Command text box. Again, the command must be on a single line.

The DBAmp.exe program returns 0 for a successful completion and -1 if any rows failed. Ensure that the **Process exit code of a successful command** is 0 (zero). A -1 will be returned for situations where some of the rows succeeded and some failed. Use the error column of the table to determine the failed rows. Rows that succeeded do not need to be resubmitted.

Your command may be different depending on the install directory.

### **Example for Embedded Single Quotes**

The following example creates a local Contacts1 Results table where the one record in the table has an embedded single quote in the last name. For this example, the last name is O'Brien.

1. Create the SOQL table:

**Create Table Contacts1\_SOQL**

**(SOQL nvarchar(max))**

2. Insert the SOQL statement into the SOQL column of the SOQL table:

**Insert Into Contacts1\_SOQL (SOQL)**

**Values('Select Id, LastName from Contact WHERE LastName = "O''Brien"')**

**Note: In the WHERE clause are all single quotes; there are no double quotes.**

3. Run the SF\_BulkSOQL stored procedure to populate the Results table:

**exec SF\_BulkSOQL 'SALESFORCE', 'Contacts1'**

Notice the Results table in the 2<sup>nd</sup> parameter of the SF\_BulkSOQL stored procedure.

### **Example passing in SOQL statement**

Do not create a SOQL table if using this technique, SF\_BulkSOQL creates the SOQL table.

The following example creates a local Leads1 Results table.

1. Run the SF\_BulkSOQL stored procedure to populate the Leads1 Results table by passing in a valid SOQL statement:

**exec SF\_BulkSOQL 'SALESFORCE', 'Leads1', '', 'Select \* from Lead'**

Notice the Results table in the 2<sup>nd</sup> parameter of the SF\_BulkSOQL stored procedure. Also, notice the 3<sup>rd</sup> parameter, it is required for a SOQL statement to be passed to SF\_BulkSOQL.

**Note:** If you use the 4<sup>th</sup> parameter (soql\_statement) of the SF\_BulkSOQL stored procedure, you must pass in a valid value for the 3<sup>rd</sup> parameter (options). The valid options for SF\_BulkSOQL are presented below.

## **Options**

**pkchunk:** SF\_BulkSOQL uses just the salesforce.com BulkAPI by default. If you would like to use the salesforce.com BulkAPI with the pkchunking header instead, add the optional pkchunk switch. SF\_BulkSOQL will submit a bulkapi job using the pkchunking header. This option should only be used for large tables.

For example, to use pkchunk:

```
Exec SF_BulkSOQL 'SALESFORCE',' Contacts1','pkchunk'
```

The default batch size will be 100,000. You can alter this using the batchsize parameter:

```
Exec SF_BulkSOQL 'SALESFORCE','  
Contacts1','pkchunk,batchsize(50000)'
```

**Note: By default, the options parameter in SF\_BulkSOQL is null.**

## SF\_BulkSOQL\_Refresh

### Usage

**SF\_BulkSOQL\_Refresh** compares the current, local SQL table containing the results of a SOQL query with that same SOQL query for a given time. The SOQL query used is the one in the `_SOQL` table produced by the SF\_BulkSOQL command. Any changes (insert, deletes or updates) are detected and the local table is updated.

Take a look at the SF\_BulkSOQL section of this chapter for more information on how to create a local SQL table with the results of a SOQL query.

**Note:** SF\_BulkSOQL\_Refresh uses the **SOAP API** to update the local SQL table.

### Syntax

```
exec SF_BulkSOQL_Refresh 'table_server', 'table_name'
```

where *table\_server* is the name of your linked server and *table\_name* is the name of the Results table provided in the SF\_BulkSOQL command.

### Example

The following creates a local AccountsContacts table containing the results from the SOQL query provided below:

```
exec SF_BulkSOQL 'SALESFORCE', 'AccountsContacts', '', 'Select  
account.name, owner.name, * from Contact'
```

The following example refreshes the local AccountsContacts table using the SOQL query located in the `_SOQL` table produced by the SF\_BulkSOQL command:

```
exec SF_BulkSOQL_Refresh 'SALESFORCE', 'AccountsContacts'
```

### Restrictions

There are several restrictions on SF\_BulkSOQL\_Refresh. These restrictions are provided below:

1. The SOQL query provided to the SF\_BulkSOQL command cannot contain a Where clause
2. The Id and SystemModstamp field must be in the Select clause of the SOQL query
3. The SOQL query cannot have any sub-selects in the Select clause



4. Any BulkAPI restrictions that are put on SOQL queries that can be found here: [https://developer.salesforce.com/docs/atlas.en-us.api\\_asynch.meta/api\\_asynch/asynch\\_api\\_using\\_bulk\\_query.htm](https://developer.salesforce.com/docs/atlas.en-us.api_asynch.meta/api_asynch/asynch_api_using_bulk_query.htm)

### **Examples of Valid and Non-Valid SOQL Queries**

Below are examples of valid SOQL queries:

**'Select account.name, owner.name, \* from Contact'**

**'Select \* from Account'**

**'Select account.name, owner.name, Id, SystemModstamp from Contact'**

**'Select Id, categories\_\_c, location\_\_c, Name, SystemModstamp from Book\_\_c'**

Below are examples of non-valid SOQL queries:

**'Select Id, FirstName, LastName from Contact'**

**'Select \* from Account where AnnualRevenue > 1000'**

**'Select Id, (Select Description from ActivityHistories) From Account'**

**'Select Count(name), Count\_distinct(name) from account'**

## SF\_CreateKeys

**NOTE: SF\_CreateKeys has been deprecated and will be removed in a future DBAmp release.**

### **Usage**

**SF\_CreateKeys** creates foreign keys for all local replicated tables of a database. This is useful for creating database diagrams and proving ad-hoc query tools with join hints.

You should run **SF\_DropKeys** to ensure that all previous foreign keys are removed before recreating them with **SF\_CreateKeys**.

### **Syntax**

```
exec SF_CreateKeys 'linked_server'
```

where *linked\_server* is the name of your linked server.

### **Example**

The following example creates foreign keys for all local, replicated tables in the database using the SALESFORCE linked server.

```
exec sf_createkeys 'SALESFORCE'
```

### **Notes**

**SF\_CreateKeys** should only be used when creating keys for Database Diagrams. See the chapter entitled *[Creating Database Diagrams and Keys](#)* for more information.

**SF\_CreateKeys** will only create foreign keys for **existing** local tables; the procedure does not create the local table itself. Therefore, you must replicate down either all the salesforce.com tables (using **SF\_ReplicateAll**) or a subset of salesforce.com tables (using **SF\_Replicate**) prior to running **SF\_CreateKeys**.

## SF\_DownloadBlobs

### Usage

**SF\_DownloadBlobs** downloads the binary content of a salesforce object (Attachment, Knowledge Article, etc.) into a directory on the SQL Server machine. **SF\_DownloadBlobs uses the salesforce Bulk API** and consumes **1 API call per file downloaded**. Make sure you have enough daily API calls in your salesforce org prior to running SF\_DownloadBlobs.

**SF\_DownloadBlobs** takes as input a local SQL Server table that is designated as the "input" table:

### Input Table

- Holds the records Ids of a Salesforce object that contains binary content on salesforce.
- Input table name prefix must be the name of a valid Salesforce object. (Ex.- Attachment and Attachment\_Test are valid, AttachmentTest is not valid)
- Input table must contain the Id field of the Salesforce object, all other fields are ignored.
- Input table must contain at least one record
- The input table can be the table created by SF\_Replicate or a table you create manually.

SF\_DownloadBlobs is a stored procedure that creates files in a local directory with the contents of the binary field(s) of a Salesforce object.

### File Name

The file name is based on the following template:

Id\_fieldName.File

For example, consider the following file name:

00P6000000BR8e1EAD\_body.File

This file belongs to the attachment with id 00P6000000BR8e1EAD and is the binary contents of the body field.

### Syntax

```
exec SF_DownloadBlobs 'table_server','input_table'
```

where *table\_server* is the name of your linked server and *input\_table* is the name of a valid input table.

### **Note**

The **Base64 Maximum Field Size** registry setting in the Registry Settings dialog on the DBAmp Configuration Program must be set to **0**.

### **Example**

The following example downloads the binary files(s) of the Attachment table into in a local directory on the server called the "Blob Directory". This example uses SF\_Replicate to create the input table.

1. Create the input table using SF\_Replicate. Normally, the Body column of the local Attachment table is null because the SF\_Replicate does not download the binary content.

**exec SF\_Replicate 'SALESFORCE', 'Attachment'**

2. Create the Blob Directory:

1. **Run the DBAmp Configuration Program**

2. **Navigate to Configuration/Options Dialog**

3. **Create a Blob Directory using the browse button**

3. Run the SF\_DownloadBlobs stored procedure to create files containing the binary field(s) of the Attachment object in the Blob Directory:

**exec SF\_DownloadBlobs 'SALESFORCE', 'Attachment'**

After execution, the Blob directory contains the individual Attachment files.

## SF\_DropKeys

**NOTE: SF DropKeys has been deprecated and will be removed from a future release.**

### **Usage**

**SF\_DropKeys** drops all foreign keys for all local replicated tables of a database. You should run **SF\_DropKeys** to ensure that all previous foreign keys are removed before recreating them with **SF\_CreateKeys**.

For more information on **SF\_DropKeys**, see the chapter entitled *Creating Database Diagrams and Keys*.

### **Syntax**

```
exec SF_DropKeys 'linked_server'
```

where *linked\_server* is the name of your linked server.

### **Example**

The following example drops all foreign keys for all local, replicated tables in the database using the SALESFORCE linked server.

```
exec sf_dropkeys 'SALESFORCE'
```

### **Notes**

- ✓ **SF\_DropKeys** should be run before SF\_Replicate or SF\_Replicate since these procedures assume that no foreign keys exist on the current local tables. We recommend that you only use SF\_CreateKeys and SF\_DropKeys when you need to database diagram.
- ✓ To create a permanent primary key on the ID field, do not use SF\_CreateKeys. Instead, SF\_Replicate will automatically create the primary key on the Id field.
- ✓ **SF\_DropKeys** will drop the keys on all tables in the salesforce backups database. Do not use SF\_DropKeys if you have created your own, non-salesforce tables with keys in the database.

## SF\_Generate

### Usage

**SF\_Generate** generates an empty local table that can be used as input of **SF\_BulkOps** for the operation specified. All columns of the salesforce.com object that are valid for the operation are included in the table. The input table name must begin with a valid Salesforce object name followed by an underscore and suffix. For example, **Account\_Load** and **Account\_FromWeb** are valid input table names. **XXX\_Load** is not a valid input table name (XXX is not a valid Salesforce.com object).

**SF\_Generate** requires you to specify an operation of either 'Insert', 'Update', 'Upsert', or 'Delete'. The local table generated will have all columns that are valid for that operation.

The output of **SF\_ColCompare** is a single empty table and the Create Table SQL used to create it.

### Syntax

```
exec SF_Generate 'op', 'linked_server', 'local_table'
```

where *op* is either 'Insert', 'Update', 'Upsert' or 'Delete', *linked\_server* is the name of your linked server and *local\_table* is the name of the local input table.

### Example

The following example creates the local table named Account\_Load for the Account object at Salesforce.com using the SALESFORCE linked server.

```
exec sf_generate 'Insert', 'SALESFORCE', 'Account_Load'
```

## SF\_Mirror

### Usage

**SF\_Mirror** is a hybrid of the SF\_Replicate and SF\_Refresh stored procedures. SF\_Mirror automatically chooses whether to do a full copy (Equivalent to SF\_Replicate) or a delta copy (Equivalent to SF\_Refresh) of the table. SF\_Mirror decides this based on a couple of criteria laid out below:

- SF\_Mirror creates a local table with the contents of the same object at Salesforce.com if the table does not already exist locally.
- If the table exists locally, SF\_Mirror decides whether to do a full copy or a delta copy of the table. SF\_Mirror makes this decision based on the created date of the local table (the last time the table was replicated).
- If the created date of the local table is **more than 7 days old**, SF\_Mirror will make a **full copy** of the table.
- If the created date of the local table is **less than 7 days old**, SF\_Mirror will do a **delta copy** of the table.
- If there are any **schema changes** detected, SF\_Mirror will make a **full copy** of the table.

The name of the local table is the same name as the Salesforce.com object (i.e. Account). By default, SF\_Mirror uses the **BulkAPI (With PKChunk header where applicable)** when making a full copy of the table locally.

**Important Note:** if the table has been mirrored locally, SF\_Mirror will use the SOAP API when the row count of the local table is below 20,000, and the BulkAPI when the row count is above 20,000 when doing a full copy. In addition, SF\_Mirror creates a primary key on the Id field of the local table.

### Syntax

```
exec SF_Mirror 'linked_server','object_name','options'
```

where *linked\_server* is the name of your linked server and *object\_name* is the name of the object. There are several optional options you may include as well.

### Example

The following example makes a full copy or delta copy of the local Account table with the current data on Salesforce.com using the SALESFORCE linked server.

```
exec SF_Mirror 'SALESFORCE', 'Account'
```

## **Using Options with SF Mirror**

SF\_Mirror will internally decide the best options to use to make a full copy or delta copy of the table. You can override the options SF\_Mirror uses in two ways:

1. The Options parameter of the SF\_Mirror stored procedure
2. The DBAmpTableOptions table

There is an order of precedence for using options with SF\_Mirror when replicating a Salesforce object locally. The order is as follows:

1. Options passed into the **Options parameter** of the SF\_Mirror stored procedure.
2. Options provided in the **Options field** of the **DBAmpTableOptions** table for the specified table.
3. If **no** options are passed into the Options parameter of the SF\_Mirror stored procedure or the Options field of the DBAmpTableOptions table for the specified table, **SF\_Mirror** will internally determine the best options to use to make a full copy of the Salesforce object locally.

**For more information on using the DBAmpTableOptions table see the “Using the DBAmpTableOptions Table” section in Chapter 3.**

### **Options**

**Batchsize:** SF\_Mirror uses a default batch size of 100,000 rows when making a **full copy**. You may need to reduce the batch size to accommodate APEX code on the Salesforce.com server. To specify a different batch size, use the batchsize(xx) option.

For example, to set the batch size to 50,000:

```
Exec SF_Mirror 'Salesforce','Account','batchsize(50000)'
```

**pkchunk:** SF\_Mirror uses the BulkAPI by default when making a **full copy**. If Salesforce allows the object to use the pkchunking header, SF\_Mirror will add it to the job. If you would like to force SF\_Mirror to use the Salesforce.com BulkAPI with the pkchunking header, add the optional pkchunk switch. SF\_Mirror will submit a BulkAPI job using the pkchunking header and poll every minute for completion. This option should be used for large tables.

For example, to use the pkchunk option and poll every 1 minute for completion:

```
Exec SF_Mirror 'Salesforce','Account','pkchunk'
```



The default batch size will be 100,000. You can alter this using the batchsize parameter:

```
Exec SF_Mirror 'Salesforce','Account','pkchunk,batchsize(50000)'
```

**Bulkapi:** SF\_Mirror uses this option by **default** when making a **full copy**. Therefore, specifying this as an option is not required for SF\_Mirror to use the BulkAPI. SF\_Mirror will submit a BulkAPI job and poll every minute for completion.

For example, to force SF\_Mirror to use the BulkAPI and poll every 1 minute for completion:

```
Exec SF_Mirror 'Salesforce', 'Account', 'bulkapi'
```

**Queryall:** SF\_Mirror **does not** include archived and deleted records of the Salesforce.com object when making a **full copy** of Salesforce data by default. To include the archived and deleted records of the Salesforce.com object in the **full copy** of Salesforce data, add the optional queryall switch.

For example, to use the queryall option with SF\_Mirror:

```
Exec SF_Mirror 'Salesforce', 'Account', 'queryall'
```

**Soap:** SF\_Mirror uses the Salesforce BulkAPI by default when making a **full copy**. If you would like to use the Salesforce.com Web Services (SOAP) API to make a **full copy** of Salesforce data, add the optional soap switch.

For example, to use the soap option with SF\_Mirror:

```
Exec SF_Mirror 'Salesforce', 'Account', 'soap'
```

**Temporal:** creates a **full copy** of the table as a system-versioned table designed to keep a full history of data changes and allow easy point in time analysis. For more information, see the section titled "Making Local Copies as Temporal Tables" in Chapter 3.

For example, to use the temporal option with SF\_Mirror:

```
Exec SF_Mirror 'Salesforce', 'Account', 'temporal'
```

**Subset:** SF\_Mirror will make a **full copy** the table locally if there is a schema change to the Salesforce object by default. If the subset option is specified, SF\_Mirror will try to determine a valid subset of columns that exist in both the local table and the table on Salesforce.com. It will do a **delta copy** of the local table based on that column subset. 'Subset' implies that new fields added to the Salesforce object will not be captured by SF\_Mirror. However, SF\_Mirror will make a **full copy** of the table every **7** days regardless of the **subset** option being specified. In addition, deleted fields will remain in the local table.

For example, to use the subset option with SF\_Mirror:

```
Exec SF_Mirror 'Salesforce', 'Account', 'subset'
```

**Full:** SF\_Mirror creates a **full copied** table with the contents of the same object at Salesforce.com every **7** days by default. You can change the number of days between making a full copied local table. To specify the number of days, use the full(xx) option.

For example, to make a full copy of the local table once a day:

**Exec SF\_Replicate 'Salesforce', 'Account', 'full(1)'**

### **Using the DBAmpSettings Table with SF Mirror**

Normally, customers use the Registry Settings page of the DBAmp Configuration Program to specify different settings to use with DBAmp. The settings in the Registry Settings page are SQL Server instance wide. If you want to specify DBAmp settings on a database by database basis, use the **DBAmpSettings** table. If the DBAmpSettings table exists in the database, the DBAmpSettings table **overrides** the settings specified in the Registry Settings page for that database. To create the DBAmpSettings table with default values, run the following in the database:

#### **Exec SF\_CreateDBAmpSettingsTable**

The DBAmpSettings table is used to configure different settings of DBAmp. To query the DBAmpSettings table, run the following query in the database:

```
select * from DBAmpSettings
```

To change a setting in the DBAmpSettings table run a SQL Update statement against the table. For example, to change the NetworkReceiveTimeout from 2400 seconds to 3000 seconds, run the following in the database:

```
Update DBAmpSettings set NetworkReceiveTimeout = 3000
```

The following DBAmp settings can be set using the DBAmpSettings table: MinimumLongSize, BulkAPIPoll, BulkAPITimeout, UseUTC, MaxBase64Size, NetworkReceiveTimeout, MetadataOverride, TriggerUserEmail, TriggerAutoResponseEmail, TriggerOtherEmail, UseDefaultAssignment, ConvertCurrency, and ToLabel.

**See the "Registry Settings Page of the DBAmp Configuration Program" section in Chapter 8 for more information on the settings.**

### **Notes**

The **SF\_Mirror** stored procedure is a hybrid of the SF\_Replicate and SF\_Refresh stored procedures. **Do not use both SF\_Mirror and SF\_Replicate/Sf\_Refresh on the same table.**

A primary index on the Id column will be automatically created when the table itself is replicated. SF\_Mirror will also preserve any secondary indexes on the local table.

By default, DBAmp does not download the values of Base64 fields but instead sets the value to NULL. This is done for performance reasons. If you require the actual values, modify the Base64 Fields Maximum Size using the DBAmp Configuration Program to some value other than 0. If you are using the DBAmpSettings table, update the MaxBase64Size field to a value other than 0.

**SF\_Mirror always creates Boolean fields on Salesforce.com as the BIT field data type in SQL Server.** SF\_Mirror **ignores** the "Use Bit Column Type" registry setting in the DBAmp Configuration Program. The following is an example of a query with one of these fields:

```
Select * from Account where IsDeleted = 'true'
```

**SF\_Mirror always creates fields as nullable in the local table.**

## SF\_MirrorAll

### Usage

**SF\_MirrorAll** is a hybrid of the SF\_ReplicateAll and SF\_RefreshAll stored procedures. SF\_MirrorAll retrieves a list of the current objects from Salesforce and automatically chooses whether to do a full copy (Equivalent to SF\_Replicate) or delta copy (Equivalent to SF\_Refresh) on each individual table in the list. If SF\_MirrorAll decides to do a full copy on the individual table, it will create a full backup with the contents of the Salesforce.com object as a local table. If SF\_MirrorAll decides to do a delta copy on the individual table, it will compare the current, local table with the contents of the same object at Salesforce.com. Any changes (insert, deletes or updates) are detected and the local table is updated with those changes.

Salesforce objects that cannot be queried via the salesforce api with no where clause (like ActivityHistory) will NOT be included. In addition, Chatter Feed objects are also skipped by the SF\_MirrorAll stored procedures because of the excessive api calls required to download those objects. You can modify the SF\_MirrorAll stored procedure to include the Feed objects if needed.

### Syntax

```
exec SF_MirrorAll 'linked_server'
```

where *linked\_server* is the name of your linked server.

### Example

The following example creates a full copy or does a delta copy of all the current data on Salesforce.com using the SALESFORCE linked server.

```
exec SF_MirrorAll 'SALESFORCE'
```

### Using the DBAmpTableOptions Table

Use the DBAmpTableOptions table to skip tables in the SF\_MirrorAll stored procedure that are not needed locally.

In addition, use the DBAmpTableOptions table to provide options for tables when using the SF\_MirrorAll stored procedure. Options can be specified to tell SF\_Mirror how to make a full copy of the table locally.

If there is not an entry for a given Salesforce object specified in the DBAmpTableOptions table, SF\_Mirror will internally decide the best way to make a full copy of the object locally.

**See the “Using the DBAmpTableOptions Table” section in Chapter 3 for more information.**

## **Notes**

The **SF\_MirrorAll** stored procedure calls the **SF\_Mirror** procedure for each Salesforce.com object.

There are some tables, like Vote and UserProfileFeed, in Salesforce that are not included in **SF\_MirrorAll**. The salesforce.com API does not allow selecting all rows from these tables. In addition, Chatter Feed objects are also skipped by the SF\_MirrorAll stored procedure because of the excessive API calls required to download those objects. You can modify the SF\_MirrorAll stored procedure to include the Feed objects if needed.

By default, DBAmp does not download the values of Base64 fields but instead sets the value to NULL. This is done for performance reasons. If you require the actual values, modify the Base64 Fields Maximum Size using the DBAmp Configuration Program to some value other than 0. If you are using the DBAmpSettings table, update the MaxBase64Size field to a value other than 0.

**Important Note:** if the table has been mirrored locally, SF\_MirrorAll will use the SOAP API when the row count of the local table is below 20,000, and the BulkAPI when the row count is above 20,000 when doing a full copy.

## SF\_Refresh

### Usage

**SF\_Refresh** compares the current, local replicated table with the contents of the same object at Salesforce.com. Any changes (insert, deletes or updates) are detected and the local table is updated. Use the **SF\_Refresh** stored procedure when you need to 'synch' your local copy with Salesforce.com.

SF\_Refresh can only be used on objects in salesforce that contain the necessary timestamp columns for tracking changes.

### Syntax

```
exec sf_refresh 'LS','object','SchemaError','verify','bulkapi'
```

where *LS* is the name of your linked server and *object* is the name of the object.

The **optional parameter** *SchemaError* should be set to **'Yes'** if you want *sf\_refresh* to automatically call *sf\_replicate* if there is a schema change to the salesforce object.

The **optional parameter** *SchemaError* can also be set to **'Subset'**. If there is a schema change to the salesforce object, *sf\_refresh* will try to determine a valid subset of columns that exist in both the local table and the table on salesforce.com and will refresh the local table based on that column subset. **'Subset'** implies that new fields added to the salesforce object will not be captured by the *sf\_refresh*. In addition, deleted fields will still remain in the local table. To alter the local table and immediately delete columns no longer in the salesforce object, set *SchemaError* to **'SubsetDelete'**. To match the schemas back up, either run *sf\_replicate* or *sf\_refresh* with *SchemaError* of **'Yes'**.

*SchemaError* can also be set to **'Repair'**. With the **'Repair'** option, *sf\_refresh* alters the method used for incrementally updating the local table. Specifically, the Max(SystemModstamp) of the local table is used to set the start time of the interval (as opposed to the last time *sf\_refresh* ran). In addition, deleted records are determined by comparing a list of the Id's locally with a list of Id's from the salesforce.com table (as opposed to using the GetDeleted function).

Note: the 'Subset' and 'SubsetDelete' options are not available for SQL 2000.

If *SchemaError* is not provided than *sf\_refresh* prints an error message and throw an error if the two schemas do not match.

The **optional parameter** *verify* can be set to **'no'**, **'warn'** or **'fail'**. The default value is 'no'. If the *verify* parameter is set to warn or fail, the *sf\_refresh* proc compares the row count of the local table with the row

count of the table on salesforce and reports any difference. If the parameter is set to 'fail' the sf\_refresh proc will fail.

The **optional parameter** bulkAPI allows sf\_refresh to use the bulkAPI instead of the salesforce web services API. This option should only be used if you are having problems with the sf\_refresh. Using the bulk API will always be slower but may be the only way to get the rows down from salesforce.com. **Normally, this option should not be specified.** To use the bulkAPI, set this option to 'bulkapi':

```
exec sf_refresh 'SALESFORCE', 'Account', 'Yes', 'no', 'bulkapi'
```

### **Example**

The following example refreshes the local Account table with the current data on Salesforce.com using the SALESFORCE linked server.

```
exec sf_refresh 'SALESFORCE', 'Account'
```

### **Using the DBAmpTableOptions Table**

Use the DBAmpTableOptions table to provide replicate options for tables when using the SF\_Refresh stored procedure. When there is a schema change detected on a table that is being refreshed by SF\_Refresh and the 'Yes' parameter is set to replicate the table, replicate options can be specified to tell SF\_Replicate how to replicate the table locally.

**See the "Using the DBAmpTableOptions Table" section in Chapter 3 for more information.**

### **Notes**

The table must contain a **SystemModstamp** column in order to be refreshed. An initial local copy of the table must exist and be less than 30 days old. If the table does not exist, use the **sf\_replicate** procedure to make a local copy before refreshing the table.

## SF\_RefreshIAD

### Usage

**SF\_RefreshIAD** compares the current, local replicated table with the contents of the same object at Salesforce.com. Any inserted or updated rows are detected and the local table is updated. Use the **SF\_RefreshIAD** stored procedure when you need to 'synch' your local copy (created with **SF\_ReplicateIAD**) with Salesforce.com.

**SF\_RefreshIAD** adds to the local table all deleted rows that are currently in the recycle bin. This is an important difference between **SF\_RefreshIAD** and **SF\_Refresh**. **SF\_RefreshIAD** uses the QueryAll api call.

**SF\_RefreshIAD** can only be used on objects in salesforce that contain the necessary timestamp columns for tracking changes.

### Syntax

```
exec SF_RefreshIAD 'linked_server', 'object_name', 'SchemaError'
```

where *linked\_server* is the name of your linked server and *object\_name* is the name of the object.

The optional parameter *SchemaError* should be set to 'Yes' if you want SF\_RefreshIAD to automatically call sf\_replicateIAD if there is a schema change to the salesforce object.

If *SchemaError* is not provided than SF\_RefreshIAD prints an error message and throw an error if the two schemas do not match.

The **optional parameter** bulkAPI allows SF\_RefreshIAD to use the BulkAPI instead of the salesforce web services API. This option should only be used if you are having problems with the SF\_RefreshIAD. Using the BulkAPI will always be slower but may be the only way to get the rows down from salesforce.com. **Normally, this option should not be specified.** To use the bulkAPI, set this option to 'bulkapi':

```
exec SF_RefreshIAD 'SALESFORCE', 'Account', 'Yes', 'bulkapi'
```

### Example

The following example refreshes the local Account table with the current data on Salesforce.com using the SALESFORCE linked server.

```
exec SF_RefreshIAD 'SALESFORCE', 'Account'
```



## **Notes**

The table must contain a **SystemModstamp** column in order to be refreshed. An initial local copy of the table must exist and be less than 30 days old. If the table does not exist, use the **sf\_replicateIAD** procedure to make a local copy before refreshing the table.

## SF\_RefreshAll

### Usage

**SF\_RefreshAll** retrieves a list of the current objects from salesforce and compares the current, local replicated table with the contents of the same object at Salesforce.com. Any changes (insert, deletes or updates) are detected and the local table is updated. Use the **SF\_RefreshAll** stored procedure when you need to 'synch' all your local tables with Salesforce.com.

**SF\_RefreshAll** does not refresh all the tables created by **SF\_Replicateall** because some of the objects in salesforce cannot be refreshed. These objects do not contain a timestamp field that tracks the datetime of the last modification. In addition, Chatter Feed objects are also skipped by the `sf_replicateall/sf_refreshall` stored procedures because of the excessive api calls required to download those objects. You can modify the stored procedures to include the Feed objects if needed.

### Syntax

```
exec sf_refreshall 'linked_server', 'SchemaError', 'verify'
```

where *linked\_server* is the name of your linked server.

The optional parameter *SchemaError* should be set to 'Yes' if you want `sf_refreshall` to automatically call `sf_replicate` if there is a schema change to the salesforce object. *SchemaError* of 'Yes' will also cause DBAmp to replicate those tables that are not refreshable.

If *SchemaError* is not provided than `sf_refreshall` prints an error message and throw an error if the two schemas do not match.

The optional parameter *verify* can be set to 'no' , 'warn' or 'fail'. The default value is 'no'. If the *verify* parameter is set to warn or fail, the `sf_refresh` proc compares the row count of the local table with the row count of the table on salesforce and reports any difference. If the parameter is set to 'fail' the `sf_refresh` proc will fail.

### Example

The following example refreshes all the local tables with the current data on Salesforce.com using the SALESFORCE linked server.

```
exec sf_refreshall 'SALESFORCE'
```

### Using the DBAmpTableOptions Table

Use the DBAmpTableOptions table to skip tables in the SF\_RefreshAll stored procedure that are not needed locally.

In addition, use the DBAmpTableOptions table to provide replicate options for tables when using the SF\_RefreshAll stored procedure. When there is a schema change detected on a table that is being refreshed by SF\_RefreshAll and the 'Yes' parameter is set to replicate the table, replicate options can be specified to tell SF\_Replicate how to replicate the table locally.

**See the “Using the DBAmpTableOptions Table” section in Chapter 3 for more information.**

### **Notes**

The tables must contain a **SystemModstamp** column to be refreshed. An initial local copy of the table must exist and be less than 30 days old. If the tables do not exist, use the **sf\_replicateall** procedure to make a local set of tables before refreshing the tables.

Tables that do not contain a **SystemModstamp** column are ignored unless the SchemaError parameter is 'Yes'. These are typically the Salesforce.com tables that end with Status (like CaseStatus).

The **SF\_RefreshAll** stored procedure calls the **SF\_Refresh** procedure for each valid local table.

There are some tables, like Vote and UserProfileFeed, in Salesforce that are not included in sf\_refreshall. The salesforce.com API does not allow selecting all rows from these tables. In addition, Chatter Feed objects are also skipped by the sf\_replicateall/sf\_refreshall stored procedures because of the excessive api calls required to download those objects. You can modify the stored procedures to include the Feed objects if needed.

## SF\_Replicate

### Usage

**SF\_Replicate** creates a local replicated table with the contents of the same object at Salesforce.com. The name of the local table is the same name as the Salesforce.com object (i.e. Account). Any schema changes in the object at Salesforce.com are reflected in the new table.

In addition, SF\_Replicate creates a primary key on the Id field of the table.

### Syntax

```
exec sf_replicate 'linked_server', 'object_name', 'options'
```

where *linked\_server* is the name of your linked server and *object\_name* is the name of the object. There are several optional options you may include as well.

### Example

The following example replicates the local Account table with the current data on Salesforce.com using the SALESFORCE linked server.

```
exec sf_replicate 'SALESFORCE' , 'Account'
```

### Options

**Batchsize:** SF\_Replicate uses the maximum allowed batch size of 2000 rows. You may need to reduce the batch size to accommodate APEX code on the salesforce.com server. To specify a different batch size, use the `batchsize(xx)` option.

For example, to set the batch size to 50:

```
Exec SF_Replicate 'Salesforce','Account','batchsize(50)'
```

**pkchunk:** SF\_Replicate uses the salesforce.com web services api by default. If you would like to use the salesforce.com bulkapi with the pkchunking header instead, add the optional pkchunk switch. SF\_Replicate will submit a bulkapi job using the pkchunking header and poll every minute for completion. This option should only be used for large tables.

For example, to use the pkchunk and poll every 1 minutes for completion:

```
Exec SF_Replicate 'Salesforce','Account','pkchunk'
```

The default batch size will be 100,000. You can alter this using the `batchsize` parameter:

```
Exec SF_Replicate 'Salesforce','Account','pkchunk,batchsize(50000)'
```

**Bulkapi:** SF\_Replicate uses the salesforce.com web services api by default. If you would like to use the salesforce.com bulkapi instead, add the optional bulkapi switch. SF\_Replicate will submit a bulkapi job and poll every minute for completion. The bulkapi should only be used for large tables.

For example, to use the bulkapi and poll every 1 minutes for completion:

**Exec SF\_Replicate 'Salesforce','Account','bulkapi'**

**NoDrop:** SF\_Replicate drops the local table by default. If you would like to use SF\_Replicate where it does not drop the local table, add the optional NoDrop switch.

For example, to use the NoDrop switch with SF\_Replicate:

**Exec SF\_Replicate 'Salesforce','Account','nodrop'**

### **Notes**

The **SF\_Replicate** stored procedure creates a full copy and downloads all the data for that object from Salesforce. If you only want to download the any changes made since you created the local copy, use the **SF\_Refresh** stored procedure instead.

A primary index on the Id column will be automatically created when the table itself is replicated.

By default, DBAmp does not download the values of Base64 fields but instead sets the value to NULL. This is done for performance reasons. If you require the actual values, modify the Base64 Fields Maximum Size using the DBAmp Configuration Program to some value other than 0.

## SF\_ReplicateAll

### Usage

**SF\_ReplicateAll** creates a full backup of your Salesforce.com data as local replicated tables with the contents of the same object at Salesforce.com. Any schema changes in the object at Salesforce.com are reflected in the new table.

Salesforce objects that cannot be queried via the salesforce api with no where clause (like ActivityHistory) will NOT be included. In addition, Chatter Feed objects are also skipped by the sf\_replicateall/sf\_refreshall stored procedures because of the excessive api calls required to download those objects. You can modify the stored procedures to include the Feed objects if needed.

### Syntax

```
exec sf_replicateall 'linked_server'
```

where *linked\_server* is the name of your linked server.

### Example

The following example replicates all the current data on Salesforce.com using the SALESFORCE linked server.

```
exec sf_replicateall 'SALESFORCE'
```

### Using the DBAmpTableOptions Table

Use the DBAmpTableOptions table to skip tables in the SF\_ReplicateAll stored procedure that are not needed locally.

In addition, use the DBAmpTableOptions table to provide replicate options for tables when using the SF\_ReplicateAll stored procedure. Replicate options can be specified to tell SF\_Replicate how to replicate the table locally.

**See the “Using the DBAmpTableOptions Table” section in Chapter 3 for more information.**

### Notes

The **SF\_ReplicateAll** stored procedure calls the **SF\_Replicate** procedure for each Salesforce.com object.

There are some tables, like Vote and UserProfileFeed, in Salesforce that are not included in **sf\_ReplicateAll**. The salesforce.com API does not allow selecting all rows from these tables. In addition, Chatter Feed objects are also skipped by the sf\_replicateall/sf\_refreshall stored procedures because

of the excessive api calls required to download those objects. You can modify the stored procedures to include the Feed objects if needed.

By default, DBAmp does not download the values of Base64 fields but instead sets the value to NULL. This is done for performance reasons. If you require the actual values, modify the Base64 Fields Maximum Size using the DBAmp Configuration Program to some value other than 0.

## SF\_ReplicateIAD

### Usage

**SF\_ReplicateIAD** creates a local replicated table with the contents of the same object at Salesforce.com, including any archived or deleted records from the recycle bin. The name of the local table is the same name as the Salesforce.com object (i.e. Account). Any schema changes in the object at Salesforce.com are reflected in the new table.

### Syntax

```
exec sf_replicateIAD 'linked_server', 'object_name'
```

where *linked\_server* is the name of your linked server and *Account* is the name of the object.

### Example

The following example replicates the local Account table with the current data on Salesforce.com using the SALESFORCE linked server. Any archived or deleted records will be included in the local table

```
exec sf_replicateIAD 'SALESFORCE' , 'Account'
```

### Notes

The **SF\_ReplicateIAD** stored procedure creates a full copy and downloads all the data for that object from Salesforce.

Do not try to **SF\_Refresh** tables create with **SF\_ReplicateIAD**. Instead you can use **SF\_RefreshIAD**.

**SF\_ReplicateIAD** only retrieves the deleted records that are currently in the salesforce recycle bin.

SF\_ReplicateIAD will retain the permanently deleted rows from run to run. Once you begin to use SF\_ReplicateIAD for a table, DO NOT USE sf\_replicate on that table. If you run sf\_replicate instead of sf\_replicateIAD, you will lose all the permanently deleted rows in the local table.

### Options

**BulkAPI:** SF\_ReplicateIAD uses the salesforce.com web services API by default. If you would like to use the salesforce.com bulkapi instead, add the optional BulkAPI switch. SF\_ReplicateIAD will submit a BulkAPI job and poll for completion. The BulkAPI should only be used for large tables.



For example, to use the BulkAPI and poll for completion:

**Exec SF\_ReplicateIAD 'Salesforce','Account','bulkapi'**

**Batchsize:** SF\_ReplicateIAD uses the maximum allowed batch size of 2000 rows. You may need to reduce the batch size to accommodate APEX code on the salesforce.com server. To specify a different batch size, use the batchsize(xx) option after the operation.

For example, to set the batch size to 50:

**Exec SF\_ReplicateIAD 'Salesforce','Account','batchsize(50)'**

**pkchunk:** SF\_ReplicateIAD uses the salesforce.com web services API by default. If you would like to use the salesforce.com BulkAPI with the pkchunking header instead, add the optional pkchunk switch. SF\_ReplicateIAD will submit a BulkAPI job using the pkchunking header and poll for completion. This option should only be used for large tables.

For example, to use the pkchunk and poll for completion:

**Exec SF\_ReplicateIAD 'Salesforce','Account','pkchunk'**

The default batch size will be 100,000. You can alter this using the batchsize parameter:

**Exec SF\_ReplicateIAD 'Salesforce','Account','pkchunk,batchsize(50000)'**

**NoDrop:** SF\_ReplicateIAD drops the local table by default. If you would like to use SF\_ReplicateIAD where it does not drop the local table, add the optional NoDrop switch.

For example, to use the NoDrop switch with SF\_Replicate:

**Exec SF\_ReplicateIAD 'Salesforce','Account','nodrop'**

## SF\_MigrateBuilder

### Usage

**SF\_MigrateBuilder** creates three stored procedures needed for a migration. The first stored procedure created by SF\_MigrateBuilder is a Replicate stored procedure used to replicate the objects locally needed in a migration. This stored procedure is created in your source database and executed in your source database.

The second stored procedure created by SF\_MigrateBuilder is a Load stored procedure used to migrate the records to the target org. This stored procedure is created in your target database and executed in your target database.

The final stored procedure created by SF\_MigrateBuilder is a Reset stored procedure used to reset the target org. This stored procedure is created in your target database and executed in your target database.

### Syntax

```
exec SF_MigrateBuilder 'KeyObjectTable', 'Identifier',  
'Source_LinkedServer', 'Target_LinkedServer',  
'Target_Database', 'Options'
```

where *KeyObjectTable* is either a single key object or a list of key objects, *Identifier* is the name you give the created stored procedure, *Source\_LinkedServer* is the name of the linked server connected to your source Salesforce org, *Target\_LinkedServer* is the name of the linked server connected to your target Salesforce org, and *Target\_Database* is the name of the target database you created. There are several optional options you may include as well.

### Example

The following example creates the three stored procedures named above. A stored procedure called Acct\_Replicate is created in your source database. Two stored procedures called Acct\_Load and Acct\_Reset are created in your target database.

```
exec SF_MigrateBuilder 'Account', 'Acct', 'SOURCE', 'TARGET',  
'Target DB'
```

Now you are ready to execute the stored procedures created by SF\_MigrateBuilder to complete a migration.

### **Replicating the Source org data**

In your source database, execute the created stored procedure: *Acct\_Replicate*. This uses the SOURCE linked server to replicate the objects locally needed for a migration.

```
exec Acct_Replicate
```

where *Acct\_Replicate* is the name of the replicate stored procedure created by SF\_MigrateBuilder.

### **Loading the Target org data**

In your target database, execute the created stored procedure: *Acct\_Load*. This migrates all records needed for a migration to your target org.

```
exec Acct_Load
```

where *Acct\_Load* is the name of the migrate stored procedure created by SF\_MigrateBuilder.

### **Resetting the Target org data if needed**

In your target database, execute the created stored procedure: *Acct\_Reset*. This resets only records that were loaded successfully into your target org for a single migration.

```
exec Acct_Reset
```

where *Acct\_Reset* is the name of the reset stored procedure created by SF\_MigrateBuilder.

To reset all records in your target org, use the *ResetAll* parameter of the *Reset* script. In your target database, execute the created stored procedure: *Acct\_Reset*, using the keyword 'all' for the *ResetAll* parameter.

```
exec Acct_Reset 'all'
```

where *Acct\_Reset* is the name of the reset stored procedure created by SF\_MigrateBuilder, and 'all' is the keyword used in the reset script to reset all records in the target org

### **Options**

**Children(All | Req | None):** The *Children* option determines which child objects of the key objects are included in the output. The default value is *None* (includes no required or non-required children of the key object(s)).

For example, to include only required children of the key object(s), use the following command:

```
Exec SF_MigrateBuilder 'Account', 'Acct', 'SOURCE', null, null,  
'children(req)'
```

**Features(A | N):** The features option determines which features to include in the output. Features are special tables that can be included in a migration. The default value is null (no features included).

| **A** |: includes Attachment

| **N** |: includes Note and ContentNote

For example, to include Attachments, Notes, and ContentNotes of the key object(s), use the following command:

```
Exec SF_MigrateBuilder 'Account', 'Acct', 'SOURCE', null, null,  
'features(AN)'
```

**Note:** any combination of A or N can be used for features

**Parents(All | Req):** The Parent option determines which parent objects of the key objects are included in the output. The default value is All (includes all required and non-required parents of the key object(s)).

For example, to include only required parents of the key object(s), use the following command:

```
Exec SF_MigrateBuilder 'Account', 'Acct', 'SOURCE', null, null,  
'parents(req)'
```

### **Example**

Children, features, and parents can be used at the same time for the options parameter. For example, to include all three options, use the following command:

```
Exec SF_MigrateBuilder 'Account', 'MigrateAcct', 'SOURCE', null,  
null, 'children(Req), features(AN), Parents(Req)'
```

### **Notes**

KeyObjectTable, Identifier, Source\_LinkedServer, Target\_LinkedServer, and Target\_Database are required parameters for SF\_MigrateBuilder. The Options parameter is optional for SF\_MigrateBuilder. The Options parameter is defaulted to include no children and no features of the key object(s).

The Source database and Target database **MUST** be in the same collation as the system.

## SF\_MigrateGraphML

### Usage

**SF\_MigrateGraphML** produces a script in the messages of your source database that can be copied and pasted into a notepad, then loaded into yED to view the relationships among the objects in a migration. Provide the Salesforce object or list of Salesforce objects you want to view in yED in the `KeyObjectTable` parameter.

### Syntax

```
exec SF_MigrateGraphML 'KeyObjectTable', 'Identifier',  
'Source_LinkedServer', 'Target_LinkedServer',  
'Target_Database', 'Options'
```

where *KeyObjectTable* is either a single key object or a list of key objects, *Identifier* is the name you give the created stored procedure, *Source\_LinkedServer* is the name of the linked server connected to your source Salesforce org, *Target\_LinkedServer* is the name of the linked server connected to your target Salesforce org, and *Target\_Database* is the name of the target database you created. There are several optional options you may include as well.

### Example

The following produces a script in the messages that can be copied and pasted into a notepad, then loaded into yED. yED provides a way to visualize the Salesforce objects and their relationships with one another in a migration. This example is for the Salesforce object Account.

```
exec SF_MigrateGraphML 'Account', 'MigrateAcct', 'SOURCE'
```

### Options

**Children(All | Req | None):** The Children option determines which child objects of the key objects are included in the output. The default value is None (includes no required or non-required children of the key object(s)).

For example, to include only required children of the key object(s), use the following command:

```
Exec SF_MigrateGraphML 'Account', 'MigrateAcct', 'SOURCE', null, null,  
'children(req)'
```

**Features(A | N):** The features option determines which features to include in the output. Features are special tables that can be included in a migration. The default value is null (no features included).

| **A** |: includes Attachment

**| N |**: includes Note and ContentNote

For example, to include Attachments, Notes, and ContentNotes of the key object(s), use the following command:

```
Exec SF_MigrateGraphML 'Account','MigrateAcct', 'SOURCE', null,  
null, 'features(AN)'
```

**Note:** any combination of A or N can be used for features

**Parents(All | Req):** The Parent option determines which parent objects of the key objects are included in the output. The default value is All (includes all required and non-required parents of the key object(s)).

For example, to include only required parents of the key object(s), use the following command:

```
Exec SF_MigrateGraphML 'Account', 'Acct', 'SOURCE', null, null,  
'parents(req)'
```

### **Example**

Children, features, and parents can be used at the same time for the options parameter. For example, to include all three options, use the following command:

```
Exec SF_MigrateGraphML 'Account','MigrateAcct', 'SOURCE', null,  
null, 'children(Req), features(AN), Parents(Req)'
```

### **Notes**

If nothing is provided in the Options parameter, it is defaulted to include no children, no features, and all parents of the key object(s).

Only use this stored procedure if you have yED installed on your machine. To install yED on your machine and to view a guide on yED, see the yED section of the chapter entitled Viewing a Migration Database Diagram.

## Chapter 8: Using the DBAmp Configuration Program

To run the DBAmp Configuration Program: from the Start menu, click on the **DBAmp Configuration** program located under DBAmp. The following chapter will outline the Options page and Registry Settings page of the DBAmp Configuration Program.

Note: You must be logged into the server as a Windows Administrator to use the DBAmp Configuration Program. Otherwise, your changes will not be saved to the registry.

### **Options Page of the DBAmp Configuration Program**

To open the Options page of the DBAmp Configuration Program, click the **Configuration** menu choice **Options**.

The Options page is used to configure the DBAmp work directory, the DBAmp performance package, SQL Server credentials, and proxy information.

The following screenshot is of the Options page of the DBAmp Configuration Program. Click each button to get an in-depth explanation of each option on the Options page.

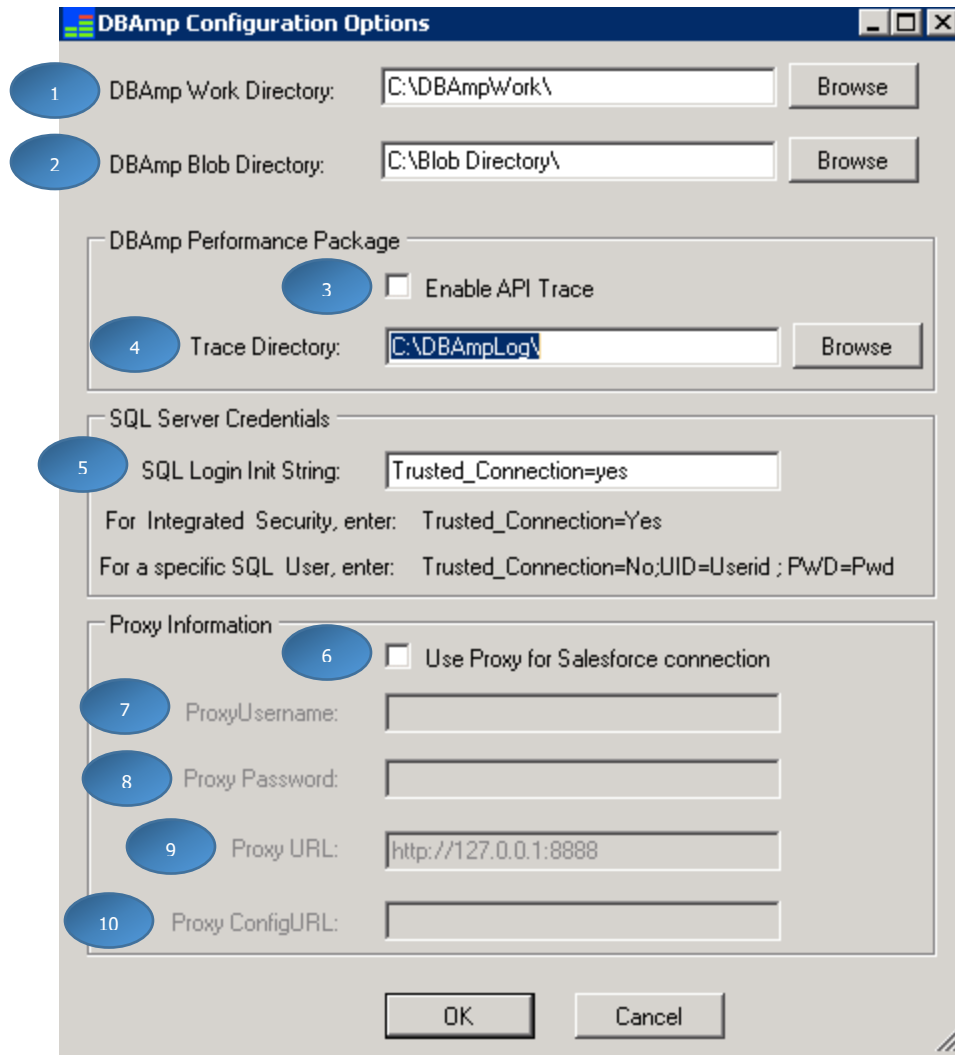

## 1. DBAmp Work Directory

The DBAmp Work Directory holds the work files produced by the Replicate stored procedures when using the **BulkApi or PKChunk options**. Use the browse button to create, find and set the work directory. Make sure the directory is on a drive with enough space. Large downloads will expand the size of this directory dramatically.

## 2. DBAmp Blob Directory

The DBAmp Blob Directory is a local directory that holds downloaded files containing the binary field(s) content of a Salesforce object. The downloaded files are produced by the SF\_DownloadBlobs stored procedure. Use the browse button to create, find and set the blob directory. Make sure the directory is on a drive with enough space. Large downloads will expand the size of this directory dramatically.



### 3. Enable API Trace

Enabling the API Trace in the DBAmp Configuration Program allows you to gather information on API calls, response times from the Salesforce server, job status information, and other performance based metrics. The API Trace produces files that contain the API information in a directory created by you.

Checking this checkbox turns on the API Trace for DBAmp.

### 4. Trace Directory

The Trace Directory is used to hold the files created by the API trace. Use the browse button to create, find and set the trace directory. Make sure the directory is on a drive with enough space.

### 5. SQL Login Init String

Enter your SQL Server credentials. If you are using Windows Authentication or Integrated Security, use the default value of **Trusted\_Connection=Yes**. For a specific SQL Server user, use the value of **Trusted\_Connection=No;UID=Userid;PWD=password**. Where userid and password are your SQL Server credentials.

### 6. Use Proxy for Salesforce connection

Enable a proxy to use for a Salesforce connection by checking the checkbox. Once enabled, enter valid proxy information for a Salesforce connection.

### 7. Proxy Username

Enter the username for the proxy login.

### 8. Proxy Password

Enter the password for the above username.

### 9. Proxy URL

Enter a direct proxy URL.

### 10. Proxy ConfigureURL

Enter a proxy script URL. When a script URL is set but the proxy address cannot be accessed, for example, the address is only available inside a corporate network but the user is logging in from home, DBAmp will use the direct URL if it has been set, or try a direct connection if the direct URL has not been set.

## Registry Settings Page of the DBAmp Configuration Program

To open the Registry Settings page of the DBAmp Configuration Program, click the **Configuration** menu choice **Registry Settings**.

The Registry Settings page is used to configure different settings of DBAmp. These settings are explained in this section.

The following screenshot is of the Registry Settings page of the DBAmp Configuration Program. Click each button to get an in-depth explanation of each setting on the Registry Settings page.

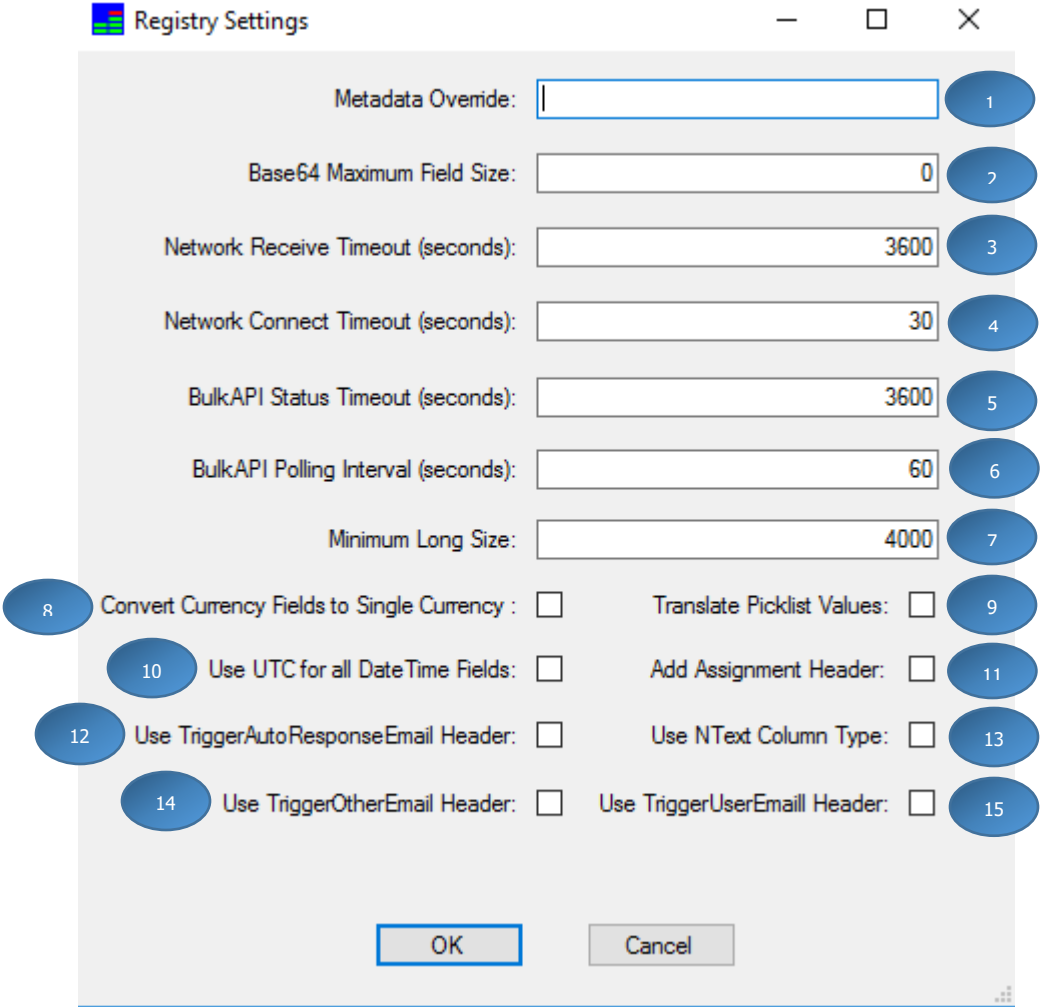

## **1. Metadata Override**

This entry allows you to modify the Scale of a decimal field or the length of a string field. In some cases, salesforce.com returns data with a greater scale than the reported metadata allows.

For example, in the RevenueForecast table, the scale of the COMMIT column is 0. But salesforce returns data for this column using a scale of 2. To alter DBAmp to use 2 as the scale, set the MetadataOverride field to the following value:

```
Revenueforecast:Commit(2)
```

Another example is the Field column in the FieldPermissions table. Use this to make the column larger so that the field names are not truncated:

```
FieldPermissions:Field(100)
```

If you need to alter multiple fields, separate the entries with a semicolon.

## **2. Base64 Maximum Field Size**

This entry modifies how DBAmp handles large binary fields when downloading from Salesforce (like the Body field of Attachments). If the field has a value greater in length than MaxBase64Size, DBAmp will not attempt to download the binary contents and instead set the value to NULL.

A value of 0 causes DBAmp to set all Base64 fields to NULL. This is the initial setting for performance reasons.

Be sure to restart SQL Server after changing this setting.

## **3. Network Receive Timeout**

This entry is the number of seconds DBAmp waits for a response from the Salesforce server.

If you are receiving "Operation Timed Out" error messages, increase this value. For some organizations you may have to set this as high as 3000 (i.e. 50 minutes).

## **4. Network Connect Timeout**

This entry is the number of seconds DBAmp waits for a successful connection to the Salesforce server. Default is 30 seconds.

## **5. BulkAPI Status Timeout**

This entry is the number of seconds DBAmp waits for a BulkAPI job to complete. SF\_Replicate with the BulkAPI option ignores this value and always uses a timeout of 12 hours.

## **6. BulkAPI Polling Interval**

This entry is the number of seconds DBAmp waits between querying for BulkAPI job completion.

## **7. Minimum Long Size**

All nvarchar fields in Salesforce with a length greater than the value will be created as nvarchar(max). Otherwise, the fields are created as nvarchar(length) where length is the length of the field.

## **8. Convert Currency Fields to Single Currency**

This entry controls whether DBAmp uses the ConvertCurrency function when retrieving currency amounts from Salesforce. A checked value forces DBAmp to use the ConvertCurrency function. See chapter 2 of this manual for more details. This setting does not apply to OpenQuery selects.

Be sure to restart SQL Server after changing this setting.

## **9. Translate Picklist Values**

This entry controls whether DBAmp uses the ToLabel function when retrieving picklists from Salesforce. A checked value forces DBAmp to use the ToLabel function. See chapter 2 of this manual for more details. This setting does not apply to OpenQuery selects.

Be sure to restart SQL Server after changing this setting.

## **10. Use UTC for all DateTime Fields**

This entry controls whether DBAmp uses UTC time or not. When returning results to SQL Server, DBAmp converts datetime values from UTC into the local timezone. In addition, any datetime values used in a WHERE clause are assumed to be local times and not UTC times.

A checked value forces DBAmp to always use UTC for all datetime values.

Be sure to restart SQL Server after changing this setting.

## **11. Add Assignment Header**

This entry controls whether DBAmp adds an AssignmentHeader to all requests made to Salesforce.com. A checked value forces DBAmp to include the header.

Be sure to restart SQL Server after changing this setting.

Note: Setting this registry switch forces DBAmp to add the header to all DBAmp operations

## **12. Use TriggerAutoResponseEmail Header**

This entry controls whether DBAmp adds an EmailHeader to all requests made to salesforce.com. This EmailHeader indicates whether to trigger auto-response rules for leads and cases. A checked value forces DBAmp to include the header.

Be sure to restart SQL Server after changing this setting.

Note: Setting this registry switch forces DBAmp to add the header to all DBAmp operations

### **13. Use NText Column Type**

If not checked, then all long text fields from Salesforce map to nvarchar(max). A checked value forces DBAmp to make all long text fields from Salesforce map to ntext.

Be sure to restart SQL Server after changing this setting.

Note: In addition, to use nvarchar(max) with linked servers, Microsoft requires that you turn on a trace switch to activate the fix: Dbcc traceon(7309)

### **14. Use TriggerOtherEmail Header**

This entry controls whether DBAmp adds an EmailHeader to all requests made to salesforce.com. This EmailHeader indicates whether to trigger an email outside the organization. A checked value forces DBAmp to include the header.

Be sure to restart SQL Server after changing this setting.

Note: Setting this registry switch forces DBAmp to add the header to all DBAmp operations

### **15. Use TriggerUserEmail Header**

This entry controls whether DBAmp adds an EmailHeader to all requests made to salesforce.com. This EmailHeader indicates whether to trigger an email that is sent to users in the organization. A checked value forces DBAmp to include the header.

Be sure to restart SQL Server after changing this setting.

Note: Setting this registry switch forces DBAmp to add the header to all DBAmp operations.

## Chapter 9: Retrieving Salesforce Metadata

DBAmp can retrieve Salesforce metadata information using the Salesforce metadata api. The **SF\_Metadata** stored procedure implements this functionality.

A couple of items to note when using this functionality:

1. Due to the nature of Salesforce metadata information, the metadata is returned to an XML type column in Salesforce. Knowledge of the XML column type and the use of XQuery expressions in SQL Select statements is required to produce results.
2. The **SF\_Metadata** stored procedure implements the List and Retrieve functions of the Salesforce Metadata API. These functions require specific type and member inputs as defined in the Salesforce Metadata API Developer's Guide found at [http://www.salesforce.com/us/developer/docs/api\\_meta/index.htm](http://www.salesforce.com/us/developer/docs/api_meta/index.htm) .

Successfully using **SF\_Metadata** is not possible without a review of the Metadata API Guide and an understanding of metadata types.

### How to run the SF\_Metadata proc

The SF\_Metadata stored proc can be executed in a query window or job step.

**Note:** The SF\_Metadata stored procedure uses the xp\_cmdshell command. If you are not an SQL Server administrator, you must have the proper permission to use this command. See the SQL Server documentation under the topic xp\_cmdshell for more information. To quickly test, run the following sql in Query Analyzer:

```
Exec master..xp_cmdshell "dir"
```

To run the **SF\_Metadata** stored procedure, use the following command:

```
Exec SF_Metadata 'List', 'SALESFORCE', 'MD_Input'
```

Or

```
Exec SF_Metadata 'Retrieve', 'SALESFORCE', 'MD_Input'
```

where 'SALESFORCE' is the name you gave your linked server in at installation and MD\_Input is the name of the input table to use.

### Using the LIST and RETRIEVE operations

The SF\_Metadata stored procedure takes as input an operation of either **List** or **Retrieve**.

The **Retrive** operation is used to retrieve xml representations of components in an organization. The input table contains rows that you provide which indicate the components you want to retrieve.

The **List** operation is used when you want a high-level view of particular metadata types in your organization. For example, you could use this operation to return a list of names of all the CustomObject or Layout components in your organization, and use this information to make a subsequent SF\_Metadata call with the **Retrieve** operation to return a subset of these components.

### Requirements for the input table

Conceptually, **the SF\_Metadata** proc takes as input a local SQL Server table you create that is designated as the "input" table. The input table name must not contain embedded blanks. Though not enforced, a naming standard for the input table to **SF\_Metadata** should be used. For example, an input table used to retrieve Settings information could be called MD\_Settings.

The input table must have the following structure:

```
CREATE TABLE MD_Settings (  
    [Name] [nvarchar](255) NULL,  
    [Member] [nvarchar](255) NULL,  
    [MetadataXML] [xml] NULL,  
    [CreatedByWildcard] [bit] NULL,  
    [CreatedByList] [bit] NULL,  
    [Error] [nvarchar](255) NULL,  
    [Id] [nchar](18) NULL  
)
```

The purpose of each column is described below:

Name	Type	Description
Name	Nvarchar(255) NULL	The type of metadata component to be retrieved. For example, a value of CustomObject will retrieve one or more custom objects as specified in the member column
Member	Nvarchar(255) NULL	One or more named components, or the wildcard character (*) to retrieve all custom metadata components of the type specified in the <name> element. To retrieve a standard object, specify it by name. For example a value of Account will retrieve the standard Account object.
MetadataXML	xml NULL	The xml describing the component is output to this column as a result of the Retrieve operation. The xml contents are described by component in the salesforce Metadata API documentation.
CreatedByWildcard	bit NULL	Upon input this column should be NULL.  If an asterisk was used for the Member column and the operation is Retrieve, then new rows will be created with a value of TRUE for this column. When the SF_Metadata procedure is executed again with operation Retrieve, the rows containing TRUE will be deleted and repopulated again.
CreatedByList	bit NULL	Upon input this column should be NULL.  If an asterisk was used for the Member column and the operation is List, then new rows will be created with a value of TRUE for this column. When the SF_Metadata procedure is executed again with operation List, the rows containing TRUE will be deleted and repopulated again.
Error	Nvarchar(255) NULL	Upon input this column should be NULL.  The Error column is an output column and is populated with any error messages that are returned from the salesforce server.
Id	nchar(18) NULL	Upon input this column should be NULL.  Specifies the ID of the component as returned by the salesforce server.



### Example: Retrieve Dependent Picklist Information

This example shows the steps needed to retrieve all dependent Picklist information for the Lead Object.

1. Create an empty input table:

```
CREATE TABLE MD_LeadPicklists (  
  [Name] [nvarchar](255) NULL,  
  [Member] [nvarchar](255) NULL,  
  [MetadataXML] [xml] NULL,  
  [CreatedByWildcard] [bit] NULL,  
  [CreatedByList] [bit] NULL,  
  [Error] [nvarchar](255) NULL,  
  [Id] [nchar](18) NULL  
)
```

2. Populate the input table. Insert a single row into the table with the Name column of CustomObject and the Member column of Lead

```
INSERT INTO MD_LeadPicklists (Name,Member)  
Values ( 'CustomObject', 'Lead')
```

3. Run the SF\_Metadata proc to retrieve the information.

```
Exec SF_Metadata 'Retrieve', 'Salesforce', 'MD_LeadPicklists'
```

4. Run the following query against the table to generate the results:

```
-- Query to select dependent picklists  
;WITH XMLNAMESPACES(DEFAULT 'http://soap.sforce.com/2006/04/metadata') SELECT  
Member  
,fn.c.value('(..../fullName)[1]','nvarchar(50)') as FieldName  
,fn.c.value('(..../controllingField)[1]','nvarchar(50)') as  
ControllingFieldName  
,fn.c.value('(../valueName)[1]','nvarchar(50)') as PicklistValue ,  
fn.c.value('(.)[1]','nvarchar(50)') as ControllingPicklistValue  
FROM MD_LeadPicklists  
cross apply metadataxml.nodes  
( '/CustomObject/fields/valueSet/valueSettings/controllingFieldValue' ) as fn(c)
```

## 5. Result:

Member	FieldName	ControllingFieldNa	PicklistValue	ControllingPicklistValue
Lead	ProductInterest__c	Industry	GC1000	series Agriculture
Lead	ProductInterest__c	Industry	GC1000	series Apparel
Lead	ProductInterest__c	Industry	GC1000	series Banking
Lead	ProductInterest__c	Industry	GC1000	series Biotechnology
Lead	ProductInterest__c	Industry	GC1000	series Construction
Lead	ProductInterest__c	Industry	GC1000	series Education
Lead	ProductInterest__c	Industry	GC5000	series Biotechnology
Lead	ProductInterest__c	Industry	GC5000	series Chemicals
Lead	ProductInterest__c	Industry	GC5000	series Construction
Lead	ProductInterest__c	Industry	GC5000	series Electronics

### Example: Retrieve Field Descriptions

This example shows how to retrieve field description information using the salesforce metadata api.

```
Drop Table MD_FieldDesc
go

CREATE TABLE MD_FieldDesc (
[Name] [nvarchar](255) NULL,
[Member] [nvarchar](255) NULL,
[MetadataXML] [xml] NULL,
[CreatedByWildcard] [bit] NULL,
[CreatedByList] [bit] NULL,
[Error] [nvarchar](255) NULL,
[Id] [nchar](18) NULL
)

INSERT INTO MD_FieldDesc (Name,Member) Values ( 'CustomObject', '*' )
-- Get a list of objects with customer fields
Exec SF_Metadata 'List', 'Salesforce', 'MD_FieldDesc'

-- Cleanup wildcard and objects that will error
Delete MD_FieldDesc where Member = '*'
Delete MD_FieldDesc where Member = 'SiteChangeList'

-- Retrieve the field metadata
```

```

Exec SF_Metadata 'Retrieve', 'Salesforce', 'MD_FieldDesc'

-- Query to select descriptions
;WITH XMLNAMESPACES(DEFAULT
'http://soap.sforce.com/2006/04/metadata') SELECT Member
,fn.c.value('(fullName)[1]','nvarchar(50)') as FieldName
,fn.c.value('(description)[1]','nvarchar(50)') as Description
--,fn.c.value('(..../fullName)[1]','nvarchar(50)') as PicklistValue
,fn.c.value('(.)[1]','nvarchar(50)') as ControllingPicklistValue
FROM MD_FieldDesc
cross apply metadatatxml.nodes ('/CustomObject/fields') as fn(c)

```

## Chapter 10: Using DBAmp Performance Package

The DBAmp Performance package allows you to capture the message output from the DBAmp stored procedures and summarize the information into performance metrics.

There are many reasons to use the DBAmp Performance Package (DPP):

- DPP creates a DBAmp\_Log table to log all message output from stored procedure execution, this allows you to locate message output errors
- DPP creates views to summarize SF\_Replicate, SF\_Refresh, and SF\_TableLoader
- DPP allows you to view run times, number of rows copied, deleted, updated, inserted, etc.
- DPP allows you to easily view which tables failed
- DPP allows you to connect to an outside analytics tool to visualize performance (ex: Excel)

Using the DBAmp Performance package you can answer questions like:

- How long does on average does it take to replicate or refresh a table?
- What is the average throughput of an SF\_TableLoader?
- What is the failure rate of the DBAmp stored procedures?

The DBAmp Performance Package contains two components:

1. The DBAmp\_Log table that contains the message output from all stored procedure execution
2. Performance Views that summarize the DBAmp\_Log table into a set of usable performance metrics.

### **Installing the DBAmp Performance Package**

The first step to install the DBAmp Performance Package is to run a script to create the needed objects.

**If you are currently using DBAmp\_Log table, installing the DBAmp Performance package will delete all data in your current DBAmp\_Log.**

DBAmp\_Log can hold up to 250,000 rows, which is approximately 50 MB of data storage. Once DBAmp\_Log reaches 250,000 rows, it deletes ¼ of itself.

### To install the DBAmp Performance Package:

1. Open the file "Create DBAmp Perf.sql" in Query Analyzer or Management Studio but do not execute it yet. The file is located in the \Program Files\DBAmp\SQL directory.
2. Make sure the default database shown on the toolbar is the salesforce backups database (and not the main database). Then, execute (F5) to add the script to the database.
3. In order to make sure that the Create DBAmp Performance script worked properly, perform two actions:

### Verifying

Run the statement below to verify that the **DBAmp\_Log table** was created:

**Select \* from DBAmp\_Log**

You should see a table similar to the screenshot below:

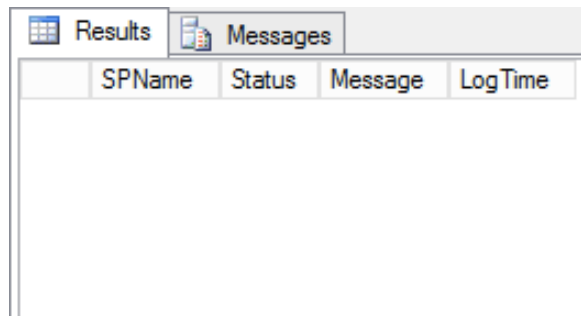

SPName	Status	Message	LogTime
--------	--------	---------	---------

- Under **Views**, in the **salesforce backups** database under **Object Explorer**, check to see that the **four performance views** were created. It should look similar to the screenshot provided below:

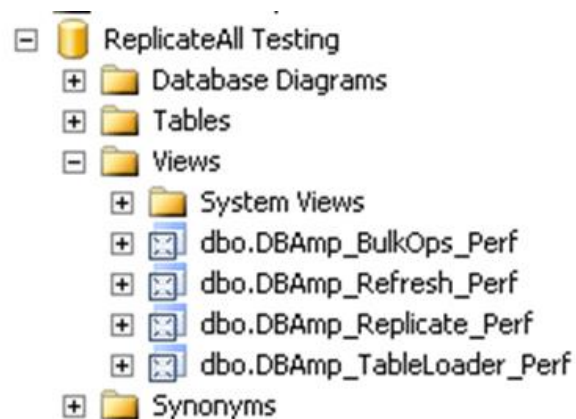

If these are **working properly**, you are ready to begin using the DBAmp Performance Package.

**Using the DBAmp\_Log Table**

All DBAmp stored procedures write their output message to the DBAmp\_Log table created by the DBAmp Performance Package. By querying the **DBAmp\_Log table**, you can view the message output from recently executed DBAmp stored procedures. This allows you to view information and find any errors related to each DBAmp stored procedure execution. The columns in the table are:

SPName	Status	Message	LogTime
SF_Replicate:42842B81-A6EA-4DBE-A1EA-6C9782A0DC9B	Starting	Parameters: SALESFORCE Account	2015-05-26 17:00:00.373
SF_Replicate:42842B81-A6EA-4DBE-A1EA-6C9782A0DC9B	Message	Drop Account_Previous if it exists.	2015-05-26 17:00:00.383
SF_Replicate:42842B81-A6EA-4DBE-A1EA-6C9782A0DC9B	Message	Create Account_Previous with new structure.	2015-05-26 17:00:00.383
SF_Replicate:42842B81-A6EA-4DBE-A1EA-6C9782A0DC9B	Message	Run the DBAmp.exe program.	2015-05-26 17:00:00.730
SF_Replicate:42842B81-A6EA-4DBE-A1EA-6C9782A0DC9B	Message	17:00:00: DBAmp Bulk Operations. V2.20.4 (c) Copy...	2015-05-26 17:00:02.727
SF_Replicate:42842B81-A6EA-4DBE-A1EA-6C9782A0DC9B	Message	17:00:00: Populating local table Account_Previous . ...	2015-05-26 17:00:02.730
SF_Replicate:42842B81-A6EA-4DBE-A1EA-6C9782A0DC9B	Message	17:00:00: DBAmp is using the SQL Native Client.	2015-05-26 17:00:02.730
SF_Replicate:42842B81-A6EA-4DBE-A1EA-6C9782A0DC9B	Message	17:00:00: Opening SQL Server rowset	2015-05-26 17:00:02.730
SF_Replicate:42842B81-A6EA-4DBE-A1EA-6C9782A0DC9B	Message	17:00:02: 3361 rows copied.	2015-05-26 17:00:02.730
SF_Replicate:42842B81-A6EA-4DBE-A1EA-6C9782A0DC9B	Message	Drop Account if it exists.	2015-05-26 17:00:02.733
SF_Replicate:42842B81-A6EA-4DBE-A1EA-6C9782A0DC9B	Message	Rename previous table from Account_Previous to A...	2015-05-26 17:00:02.737
SF_Replicate:42842B81-A6EA-4DBE-A1EA-6C9782A0DC9B	Message	Create primary key on Account	2015-05-26 17:00:02.737
SF_Replicate:42842B81-A6EA-4DBE-A1EA-6C9782A0DC9B	Successful	Ending - Operation Successful.	2015-05-26 17:00:02.753
SF_ReplicateAll:9FDOC1E0-6DA4-45E2-B60E-FD7E1DA705	Starting	Parameters: SALESFORCE	2015-05-26 17:46:11.760
SF_Replicate:39212D54-0F1B-4A19-846C-4DB2F8E48378	Starting	Parameters: SALESFORCE AcceptedEventRelation	2015-05-26 17:46:18.773
SF_Replicate:39212D54-0F1B-4A19-846C-4DB2F8E48378	Message	Drop AcceptedEventRelation_Previous if it exists.	2015-05-26 17:46:18.777
SF_Replicate:39212D54-0F1B-4A19-846C-4DB2F8E48378	Message	Create AcceptedEventRelation_Previous with new s...	2015-05-26 17:46:18.777
SF_Replicate:39212D54-0F1B-4A19-846C-4DB2F8E48378	Message	Run the DBAmp.exe program.	2015-05-26 17:46:18.853
SF_Replicate:39212D54-0F1B-4A19-846C-4DB2F8E48378	Message	17:46:18: DBAmp Bulk Operations. V2.20.4 (c) Copy...	2015-05-26 17:46:19.310

Column Name	Documentation
SPName	Unique ID of each execution
Status	Status of the execution
Message	All messages related to each execution
LogTime	The date and time the execution started (status = starting) and ended (status = successful/failed)

Run the statement below to select all rows and columns of the DBAmp\_Log Table:

**Select \* from DBAmp\_Log**

## Using the Performance Views

### Why Views?

- The views summarize the raw message output in the DBAmp\_Log table into views that can be analyzed for performance.
- The views can be used to import performance data into Excel or other analytical tools

There are four performance views included in the DBAmp Performance Package. The four views and their documentation are listed below:

### DBAmp\_Replicate\_Perf view

The DBAmp\_Replicate\_Perf view contains the data and metrics of all SF\_Replicate, SF\_ReplicateIAD, and SF\_Replicate3 executed. The columns in the view are:

SPName	LogTime	LinkedServer	Object	RowsCopied	RunTimeSeconds	Failed
SF_Replicate:028D7A6A-B270-4A3B-BAEA-BF025BA8F9BC	2015-05-26 17:48:13.667	SALESFORCE	OpportunityStage	10	1	False
SF_Replicate:03F8407F-6B4D-4244-8539-185B51A4A1D2	2015-05-26 17:48:37.193	SALESFORCE	ThirdPartyAccountLink	0	1	False
SF_Replicate:04F533C1-0180-4260-AC84-EE8C920201D3	2015-05-26 17:46:47.533	SALESFORCE	Campaign	4	1	False
SF_Replicate:055438FC-1273-49B6-AFE9-7DD830259A72	2015-05-26 17:47:28.043	SALESFORCE	CustomPermissionDependency	0	1	False
SF_Replicate:061D20F0-EA1F-4C20-91B5-B51F75D3B4C0	2015-05-26 17:48:05.733	SALESFORCE	MacroHistory	0	1	False
SF_Replicate:07A70340-5D41-47F8-A5B7-E4D30588B4AC	2015-05-26 17:47:39.797	SALESFORCE	ExternalDataSource	0	1	False
SF_Replicate:08096C9C-2A73-43D3-BFAE-7406248FB00B	2015-05-26 17:46:31.607	SALESFORCE	AccountShare	0	1	False
SF_Replicate:08375692-0A7E-4436-BB48-E7B0ED201FB7	2015-05-26 17:47:08.970	SALESFORCE	CollaborationGroup	1	1	False
SF_Replicate:0A8A79E5-B5A3-4B29-9A79-22947A846A76	2015-05-26 17:47:11.377	SALESFORCE	Contact	28	1	False
SF_Replicate:0AF41E86-B8E7-420E-A4B7-BBF85BF8EC7F	2015-05-26 17:47:12.453	SALESFORCE	ContactHistory	0	1	False
SF_Replicate:0C5081A8-D6F4-44BC-AFF9-3F364FD8F7D1	2015-05-26 17:47:49.190	SALESFORCE	GrantedByLicense	0	1	False
SF_Replicate:0E24E691-91BD-4F25-9771-21BE822EDC0E	2015-05-26 17:48:14.180	SALESFORCE	Order	0	1	False
SF_Replicate:0E680709-429D-4E64-A384-137F5D4B9278	2015-05-26 17:46:41.640	SALESFORCE	Attachment	1	1	False
SF_Replicate:0E81AF80-8F49-4489-BC0F-E2E599AEF961	2015-05-26 17:47:32.173	SALESFORCE	DcSocialProfileHandle	0	1	True
SF_Replicate:0F2C25D7-40B8-405C-8EC1-07FF1E0C7AF6	2015-05-26 17:47:59.837	SALESFORCE	LoginHistory	740	5	False
SF_Replicate:0FF96702-F1A8-4860-9751-864A6FE14022	2015-05-26 17:46:30.370	SALESFORCE	AccountContactRole	0	1	False
SF_Replicate:14B7FDE3-03F9-4419-A1DC-B362FBAF6720	2015-05-26 17:47:57.417	SALESFORCE	LeadHistory	0	1	False
SF_Replicate:150FFCCF-84F5-4D18-83A2-B3837A16084C	2015-05-26 17:47:37.650	SALESFORCE	EntityDefinition	386	1	False
SF_Replicate:15B20B45-4B70-4C3B-9217-745D6FB0C280	2015-05-26 17:48:28.097	SALESFORCE	RecentlyViewed	50	1	False

Column Name	Documentation
SPName	Unique ID of each execution
LogTime	The date and time the execution started (status = starting) and ended (status = successful/failed)
LinkedServer	Name of the DBAmp linked server used
Object	Name of object
RowsCopied	Number of rows copied during each execution
RunTimeSeconds	Number of seconds the execution took to run

Failed	If the execution failed or not (True = failed)
--------	------------------------------------------------

Run the statement below to select all rows and columns of the DBAmp\_Replicate\_Perf:

**Select \* from DBAmp\_Replicate\_Perf**

**DBAmp\_Refresh\_Perf view**

The DBAmp\_Refresh\_Perf view contains the data and metrics of all SF\_Refresh and SF\_RefreshIAD executed. The columns in the view are:

SPName	LogTime	LinkedServer	Object	RowsUpdatedOrInserted	RowsDeleted	RunTimeSeconds	Failed
SF_Refresh:93E061B9-84EC-4D03-B39C-8DD255B39067	2015-05-26 19:24:10.680	SALESFORCE	AcceptedEventRelation	0	0	1	False
SF_Refresh:895FB393-6DE5-45E3-9DA9-0A1E4280D561	2015-05-26 19:24:10.990	SALESFORCE	Account	0	0	1	False
SF_Refresh:E6509F15-08D1-4E9C-B7DA-9AD15ABAFEF2	2015-05-26 19:24:11.297	SALESFORCE	AccountCleanInfo	0	0	1	False
SF_Refresh:2B61BA16-4BC3-497B-BDA6-53CEFF59FB2D	2015-05-26 19:24:11.643	SALESFORCE	AccountContactRole	0	0	1	False
SF_Refresh:D02CA223-65CA-4454-8778-8C334162E21F	2015-05-26 19:24:11.817	SALESFORCE	AccountHistory	0	0	1	False
SF_Refresh:37B5D25B-E005-4837-B531-6AF9D5B77E6B	2015-05-26 19:24:12.080	SALESFORCE	AccountPartner	0	0	1	False
SF_Refresh:AB2CB37F-5EB5-4F2B-8DAF-959799D08BC4	2015-05-26 19:24:12.250	SALESFORCE	ActionLinkGroupTemplate	0	0	1	False
SF_Refresh:2DF72790-8FE3-45FC-AD8E-DBB543CDDFBFE	2015-05-26 19:24:12.427	SALESFORCE	ActionLinkTemplate	0	0	1	False
SF_Refresh:FDA21ADE-1BA8-4403-99BD-52C7EEC6012C	2015-05-26 19:24:12.643	SALESFORCE	AdditionalNumber	0	0	1	False
SF_Refresh:A9C9D5C8-A32D-4F73-A18A-37958D5FE451	2015-05-26 19:24:12.850	SALESFORCE	Announcement	0	0	1	False
SF_Refresh:B252C601-0F83-4B6F-BBDB-FBF7C116365E	2015-05-26 19:24:13.083	SALESFORCE	ApexClass	0	0	1	False
SF_Refresh:65E6E9C9-CD59-469A-9FEA-BEA9D8577D79	2015-05-26 19:24:13.447	SALESFORCE	ApexComponent	0	0	1	False
SF_Refresh:B77E84DD-FDA5-4A60-B0DE-204884480190	2015-05-26 19:24:13.677	SALESFORCE	ApexLog	0	0	1	False
SF_Refresh:FCB7BCB9-52FE-41AC-B937-732C6A3FD44C	2015-05-26 19:24:13.840	SALESFORCE	ApexPage	0	0	1	False
SF_Refresh:FB68266E-4C84-4407-BE0F-843F03CCD335	2015-05-26 19:24:14.037	SALESFORCE	ApexTestQueueItem	0	0	2	False
SF_Refresh:ED2C8EA8-5B9D-4503-96E4-A739852437A7	2015-05-26 19:24:16.210	SALESFORCE	ApexTestResult	0	0	1	False
SF_Refresh:970AB25B-385F-49D0-8EAF-157042698C12	2015-05-26 19:24:17.207	SALESFORCE	ApexTrigger	0	0	1	False
SF_Refresh:CE6A5FA6-95E4-44E3-BC4E-ECC9E92F905C	2015-05-26 19:24:17.520	SALESFORCE	AppMenuItem	0	0	1	False
SF_Refresh:46A25A3E-F057-47ED-892C-CC529472D04A	2015-05-26 19:24:18.233	SALESFORCE	Asset	0	0	1	False

Column Name	Documentation
SPName	Unique ID of each execution
LogTime	The date and time the execution started (status = starting) and ended (status = successful/failed)
LinkedServer	Name of the DBAmp linked server used
Object	Name of object
RowsUpdatedOrInserted	Number of rows updated/inserted
RowsDeleted	Number of rows deleted
RunTimeSeconds	Number of seconds the execution took to run
Failed	If the execution failed or not (True = failed)



Run the statement below to select all rows and columns of the DBAmp\_Refresh\_Perf:

**Select \* from DBAmp\_Refresh\_Perf**

**DBAmp\_TableLoader\_Perf view**

The DBAmp\_TableLoader\_Perf view contains the data and metrics of all SF\_TableLoaders executed. The columns in the view are:

21	SF_TableLoader	SF_TableLoader:1526517B-1A6C-4367-BAA4-1C085C70507	2018-05-02 08:31:41.480	SALESFORCE	Account_JobIdTesting	81	False
22	SF_TableLoader	SF_TableLoader:15EE2485-E76D-430B-9988-85115438B36	2018-05-01 14:19:19.110	SALESFORCE	Account_JobIdTesting	109	False
23	SF_TableLoader	SF_TableLoader:1629D09B-3755-4ACE-97EB-102DA9421C3	2017-11-13 10:17:23.780	ISV	Account_Timing5000rows	50	False
24	SF_TableLoader	SF_TableLoader:178E55AA-2993-4F19-9134-DEF1F192587	2018-05-02 13:52:29.433	SALESFORCE	Account_JobIdTestingUpd...	67	True
25	SF_TableLoader	SF_TableLoader:18C89B61-16AC-4A09-A4DB-9CB4D3A13DC	2017-11-14 08:52:56.620	SALESFORCE	Contact_ExternalId	19	True
26	SF_TableLoader	SF_TableLoader:197E6F2F-0B53-4BB2-915E-8AAD1F73FCC	2017-11-13 10:13:34.800	ISV	Account_Timing5000rows	36	False

Column Name	Documentation
SPName	Unique ID of each execution
LogTime	The date and time the execution started (status = starting) and ended (status = successful/failed)
TableLoaderAction	The execution action (update, insert, upsert, delete, etc.)
LinkedServer	Name of the DBAmp linked server used
LoadTable	Name of the local SQL input table used containing the data
RowsRead	Total number of rows read during each execution
RowsSuccessful	Number of rows successfully read
RowsFailed	Number of rows that failed
RunTimeSeconds	Number of seconds the execution took to run
Failed	If the execution failed or not (True = failed)

Run the statement below to select all rows and columns of the DBAmp\_TableLoader\_Perf:

**Select \* from DBAmp\_TableLoader\_Perf**

## Enabling the Performance Trace

Enabling the Performance Trace in the DBAmp Configuration Program allows you to gather information on API calls, response times from the Salesforce server, what a job is actually doing, and other performance based metrics. The Performance Trace produces files that contain the performance information in a directory created by you on the C: drive.

To enable and use the Performance Trace takes five steps:

**Note: All of these steps must be performed on the SQL Server machine where DBAmp is installed.**

1. Create a new directory called c:\DBAmpLog This tells DBAmp where to put the file output from the Performance Trace. Be sure to set the Security of this directory to allow READ and WRITE access to the User group.. To check this, right click on the DBAmpLog directory, choose Properties. Click on the Security tab of the DBAmpLog Properties dialog box. In the Group or user names box, highlight Users. In the Permissions for Users box, make sure Write has a checkmark under the Allow column.
2. Run the DBAmp Configuration Program, navigate to menu choice Options, and check the **Enable Performance Trace** checkbox. Checking this checkbox turns on the Performance Trace for DBAmp.
3. Enter the directory you created on the C: drive in the **Trace Directory** textbox. Be sure the directory entered has already been created on the C: drive and is a valid directory. It should look similar to the screenshot below:

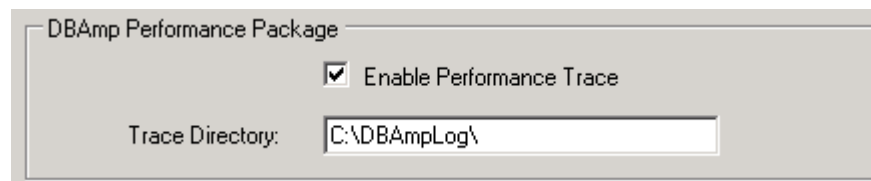

4. Click **Ok** on the Options page.
5. Run the query displayed by clicking **Ok** in SQL Management Studio.

To review the performance information produced, view the files in the created directory on the C: drive. To **turn off** the Performance trace, uncheck the Enable Performance Trace checkbox on the Options page of the DBAmp Configuration Program.

# Chapter 11: MigrateAmp

## What is MigrateAmp?

MigrateAmp is a tool used for migrating data from a source Salesforce environment to a target Salesforce environment. This can include org to org, or org to sandbox. MigrateAmp takes the objects and records from a source environment, and builds stored procedures that are executed to migrate data to a target environment. This tool can be very useful for many reasons:

- MigrateAmp builds all stored procedures and load scripts used automatically. This makes migrating very easy and efficient, while saving the organization time and money. It also allows you to modify the scripts to fit individual migration needs.
- MigrateAmp allows data to be migrated from any source Salesforce org to any target Salesforce org or sandbox
- MigrateAmp makes the testing of data in Sandboxes easier by allowing an easy path from a Salesforce org to a sandbox
- MigrateAmp will not affect production while in use
- MigrateAmp can be used to reset the target Salesforce org
- MigrateAmp allows any combination of objects and data to be migrated
- MigrateAmp, in conjunction with yED, a visualization software, provides a platform to visualize the relationships among Salesforce objects in a migration

### MigrateAmp contains two components:

1. SF\_MigrateBuilder
2. SF\_MigrateGraphML

## Installing MigrateAmp

To successfully install and use MigrateAmp, follow the instructions below.

### Installing the MigrateAmp User Interface:

1. Navigate to the MigrateAmpInstall.exe file on the SQL Server machine where DBAmp resides. The file is located in the \Program Files\DBAmp directory.
2. Run the MigrateAmpInstall.exe file to install the MigrateAmp User Interface.
3. If you want to install and use the MigrateAmp User Interface on a client machine, copy the MigrateAmpInstall.exe from the SQL Server machine to your client machine. Then, run the MigrateAmpInstall.exe file.

### Preparing to use MigrateAmp:

1. Create a **source database**, which will be used to hold the locally copied Salesforce objects for a migration
2. Run the Create DBAmp SPROCS in the **source database**
3. For the **source database**, create a **linked server** that connects to your **source Salesforce org**
4. Open the file "Create MigrateAmp SPROCS.sql" in query analyzer or Management studio, but do not execute it yet. The file is located in the \Program Files\DBAmp\SQL directory.

5. Make sure the default database shown on the toolbar is your **source database** (and not the main database or target database). Then, execute (F5) to add the script to the source database.
6. In order to make sure that the Create MigrateAmp SPROCS **worked properly**, navigate to the stored procedures in the source database and check to see that two stored procedures were created: **SF\_MigrateBuilder** and **SF\_MigrateGraphML**.
7. Create a **target database**, which will be used to the data in a migration to your **target Salesforce org**
8. Run the Create DBAmp SPROCS in the **target database**
9. For the **target database**, create a **linked server** that connects to your **target Salesforce org**

### **MigrateAmp Approaches**

There are two approaches to use DBAmp:

1. Using the MigrateAmp User Interface
2. Using the MigrateAmp Scripts in SQL Management Studio

#### **Using the MigrateAmp User Interface:**

The MigrateAmp User Interface is an easy way to run SF\_MigrateBuilder and create the needed stored procedures to complete a migration. Use the MigrateAmp User Interface to enter in the needed information and the application will automatically run SF\_MigrateBuilder to create the stored procedures. Visit the "Running SF\_MigrateBuilder in User Interface" section for more information.

#### **Using the MigrateAmp Scripts in SQL Management Studio:**

In this approach, SF\_MigrateBuilder is being executed in SQL Management Studio. Executing the SF\_MigrateBuilder stored procedure, with correct parameters, will create the needed stored procedures to complete a migration. Visit the "Running SF\_MigrateBuilder in SQL Management Studio" section for more information.

### **Understanding MigrateAmp Concepts**

There are key concepts that need to be understood before using MigrateAmp. The migration of data, and particularly migration involving the Salesforce data model, is a very complicated task. The Salesforce data model is very complex compared to other data models. For example, a Salesforce object can have both required and non-required relationships to other objects. Circular references can occur among objects. And unlike a normal relational database, the Salesforce data model can contain polymorphic keys. This section will dive into some of the key concepts, and give a high-level education of MigrateAmp and how it works.

#### **What is a Migration?**

A migration is the process of transferring data from a source environment to a target environment. In MigrateAmp's case, it is transferring data from a source Salesforce org to a target Salesforce org. The target org can be either a sandbox org or another org. In a migration, there is a certain order that objects and their data have to be migrated for the migration to be successful. MigrateAmp automatically produces the object migration order

and maintains the relationships between the objects during the migration. You provide MigrateAmp the key object(s) to be migrated, and MigrateAmp does the rest.

### **Understanding Challenges of Migration**

Migration has two major challenges to overcome: determining object load order and maintaining foreign keys.

The first major challenge is the ordering of objects in a migration. The import of objects to the target must be correctly sequenced for the migration to be successful. It is very difficult in any data model to get the order of objects sequenced correctly, but it is especially challenging with the Salesforce data model. The Salesforce data model has the concept of required and non-required relationships among objects. It also has the concept of circular references. These make it very challenging to get the correct order of objects for a migration.

To understand order, take for example, the migration of Salesforce Opportunity records. In order to successfully migrate Opportunity, we have to determine what objects are required to be migrated before the Opportunity records can be migrated. This is because the Opportunity records have parents that are required relationships with Opportunity. In this example the Account records would be a required parent of Opportunity, because Opportunity has a required relationship with Account via AccountId. Therefore, the Account records would need to be migrated before the Opportunity records are migrated. But, for the Account records to be migrated, the User records have to be migrated because of a required relationship via OwnerId. This example sequence is the basis for how an order of objects is established for a migration. MigrateAmp determines this and creates an order of objects for any migration automatically.

The second major challenge of migration is maintain foreign key relationships while loading the target org. In salesforce, a new primary key id is given to every record in an object when that record is inserted. Therefore, all foreign keys that point to the record must be changed to use the newly assigned Id.

MigrateAmp automatically keeps a cross reference table of old ids to new ids and uses this cross reference table to ensure that the foreign keys are maintained on the target org.

### **What is a Key Object?**

In MigrateAmp, a key object is an object that is essential to migrate from your source org to your target org. The key object(s) are the only objects in a migration that will have its required and non-required fields fully populated. Based on the key object(s) provided, MigrateAmp will automatically construct the migration and fix up the fields that point to the required and non-required relationships of the key object(s). One or more key objects can be supplied for a migration. If more than one key object is chosen for a migration, a table will need to be constructed for the key objects. The instructions for constructing this table are provided in the

KeyObjectTable section of the MigrateAmp Parameters in the chapter entitled Using MigrateAmp.

### **Understanding Parent/Child Relationships**

A **parent** object of a relationship is the object identified by a foreign key field. A **child** object of a relationship is the object that contains the foreign key field that points back to the parent object. A **foreign key field** is a field in the child object that uniquely identifies a row in the parent object.

For example, take the relationship between the Account and Contact object. In this relationship, Account is the parent object and Contact is the child object. Account is the parent object because another object has a foreign key field pointing back to the Account object. In this case, Contact has the AccountId field pointing back to the Account object. Contact is the child object because it contains the foreign key field, AccountId, that points back to the parent object, Account.

The example from above is displayed in the diagram shown below:



This depicts the example of the Account object being the parent of the Contact object.

### **Required Relationships**

A **Required Relationship** is a relationship between a parent object and a child object where the foreign key field of the child object is **required** to have a value.

The **Required parents** of a child object are all the parent objects that are identified by a foreign key field of the child object where the foreign key field is **required** to have a value.

The **Required children** of a parent object A are all child objects containing a foreign key field pointing to object A where the foreign key field of the child object is **required** to have a value.

For each key object given in a migration, all required parents of the key object, all required children and grandchildren of the key object, and all required parents of the required children and grandchildren of the key object are included in the migration. This is so the key object(s) in the migration are fully populated. There are options where you can indicate that you do not want the required children to be included in the migration. See the Options section under MigrateAmp Parameters in the chapter Using MigrateAmp for further details.

### **Non-Required Relationships**

A **Non-Required Relationship** is a relationship between a parent object and a child object where the foreign key field of the child object is **not required** to have a value. For example, the Opportunity object contains a foreign key field that points to a Campaign parent object. However, opportunities are not required to have campaigns and therefore the relationship is a **Non-Required Relationship**.

The key object(s) supplied in the migration are the only object(s) where the non-required parent objects of the key object(s) **are** included in the migration.

For all objects in the migration that are not key objects, the non-required parents and non-required children **are not** included.

### **Migration Database Diagram Example**

The screenshot below is an example of a database diagram for the Opportunity object. In this example, all objects associated with a migration of the Opportunity object are included in the diagram. This means all required and non-required objects associated with the Opportunity object are included in the migration. This diagram shows the relationships between objects in a typical migration. This was constructed using yED Graph Editor. To view instructions on how to download and use yED Graph

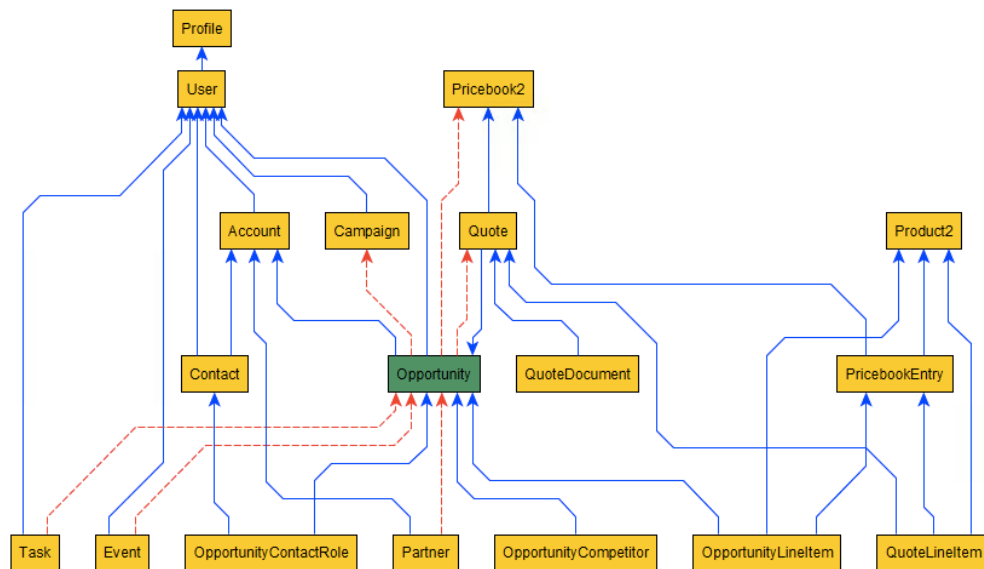

Editor, see Using yED in the chapter entitled Viewing a Migration Database Diagram .

Opportunity is marked as green, because it is a key object. The red dotted lines are non-required relationships. The blue lines are required relationships. This depicts the order of objects in a migration for Opportunity. For example, starting at the top, the parents of the Opportunity key object (Profile, User, Account) are loaded first. Then the key object Opportunity is loaded. Finally, MigrateAmp loads the required and non-required children for Opportunity: OpportunityContactRole, OpportunityCompetitor, OpportunityLineItem, Quote, QuoteLineItem, Partner, Task, and Event.

### **Circular References**

A **circular reference** is when two or more objects each have required foreign key field that refer to one another, causing a closed loop.

Salesforce allows circular references in their data model. In migration, circular references are prohibited because an order of objects would not be able to be determined. The records from the objects containing a circular reference would have to be migrated at the same exact time. This is not possible; therefore circular references are prohibited. MigrateAmp detects circular references and throws an error if one is detected. If circular references are detected, they will have to be removed before a migration.

### **Polymorphic Key**

Polymorphic keys are foreign key fields that can refer to more than one object as a parent. For example, either a Contact or Lead can be a parent of a task. Another example would be all of the parents of Attachment through a ParentId foreign key field. Polymorphic keys are challenging to confront because the same foreign key field can point to many different objects.

MigrateAmp handles polymorphic keys by loading only the records of a child object where the polymorphic foreign key points to a key object(s).

### **MigrateAmp Workflow**

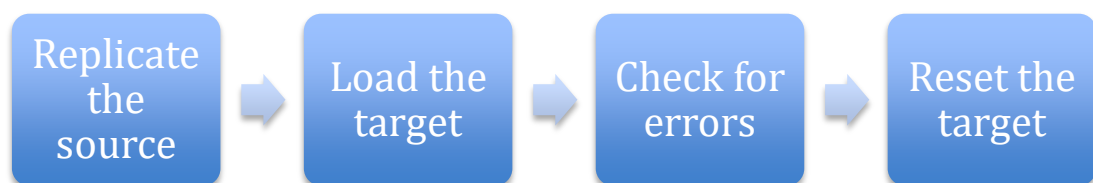

The diagram above is depicting a typical workflow for a migration using MigrateAmp. Migrations are continuous and more than likely not going to be totally successful the first time you go through the workflow.

The first step in the workflow is replicating the objects that are needed for a migration into your source database from Salesforce.com. MigrateAmp creates the stored procedure to do this. The created stored procedure has



the suffix **\_Replicate appended** to indicate the purpose of the proc. This created stored procedure uses SF\_Replicate calls to replicate all objects needed for a migration into your source database

The second step in the workflow is loading the records that were replicated into your source database into your target org on Salesforce.com. MigrateAmp creates the stored procedure to do this. This created stored procedure has the suffix **\_Load appended** to indicate the purpose of the proc. This created stored procedure uses SF\_TableLoader to load the records into the target org. The results of this stored procedure can then be used for error handling if the migration is not successful.

The third step in the workflow is error handling. In this step, once the Load stored procedure created by MigrateAmp is executed, any errors that occurred from that execution are produced in the messages. Migrations are very complex and errors do occur. The messages provide a means of debugging these errors.

The final step in the workflow is resetting the target org. There are two main reasons to reset the target org. The first main reason is because there were errors in the migration. Being able to handle errors in the source data and reset the target org to retry a migration is a key feature of this product. The second main reason that you would want to reset the target org is because you are done using the data in the target or want to delete it out for a different migration.

This step in the workflow uses SF\_TableLoader to delete records from the target org to work as a reset if the migration is not successful or if the migration is complete. The created stored procedure to do this has the suffix **\_Reset appended** to indicate the purpose of the proc.

These four steps in the MigrateAmp workflow are key concepts in understanding how migrations work and how MigrateAmp works.

## **MigrateAmp Architecture**

The diagram below depicts the workflow of migration using MigrateAmp.

### **Source DB**

Holds the local copies of the tables needed for a migration.

- **Source Linked Server:** connects the source Salesforce org to the Source DB
- **Account and Contact Tables:** the local tables copied down from the source org into the Source DB. These tables are created by the OrgMigrate\_Replicate stored procedure.
- **DBAmp Stored Procs:** SF\_Replicate, SF\_TableLoader, etc.
- **MigrateAmp Stored Procs:** SF\_MigrateBuilder, SF\_GraphML, etc.

- **OrgMigrate\_Replicate:** this stored procedure replicates the tables locally into the Source DB from the source org. In this case, the Account and Contact tables are replicated locally.

## **Target DB**

Used to load and reset the target Salesforce org.

- **Target Linked Server:** connects the target Salesforce org to the Target DB.
- **Account\_Load\_OrgMigrate and Contact\_Load\_OrgMigrate tables:** these tables contain the row data to load the target org. These tables are created by the OrgMigrate\_Load stored procedure.
- **Account\_Reset\_OrgMigrate and Contact\_Reset\_OrgMigrate tables:** these tables contain the row data used to reset the target org. These tables are created by the OrgMigrate\_Reset stored procedure.
- **DBAmp Stored Procs:** SF\_Replicate, SF\_TableLoader, etc.
- **OrgMigrate\_Load:** this stored procedure creates the load tables and loads the data into the target org. In this case, the Account\_Load\_OrgMigrate and Contact\_Load\_OrgMigrate tables are loaded into the target org.
- **OrgMigrate\_Reset:** this stored procedure creates the reset tables and resets the data in the target org. In this case, the Account\_Reset\_OrgMigrate and Contact\_Reset\_OrgMigrate tables are used to reset the target org.

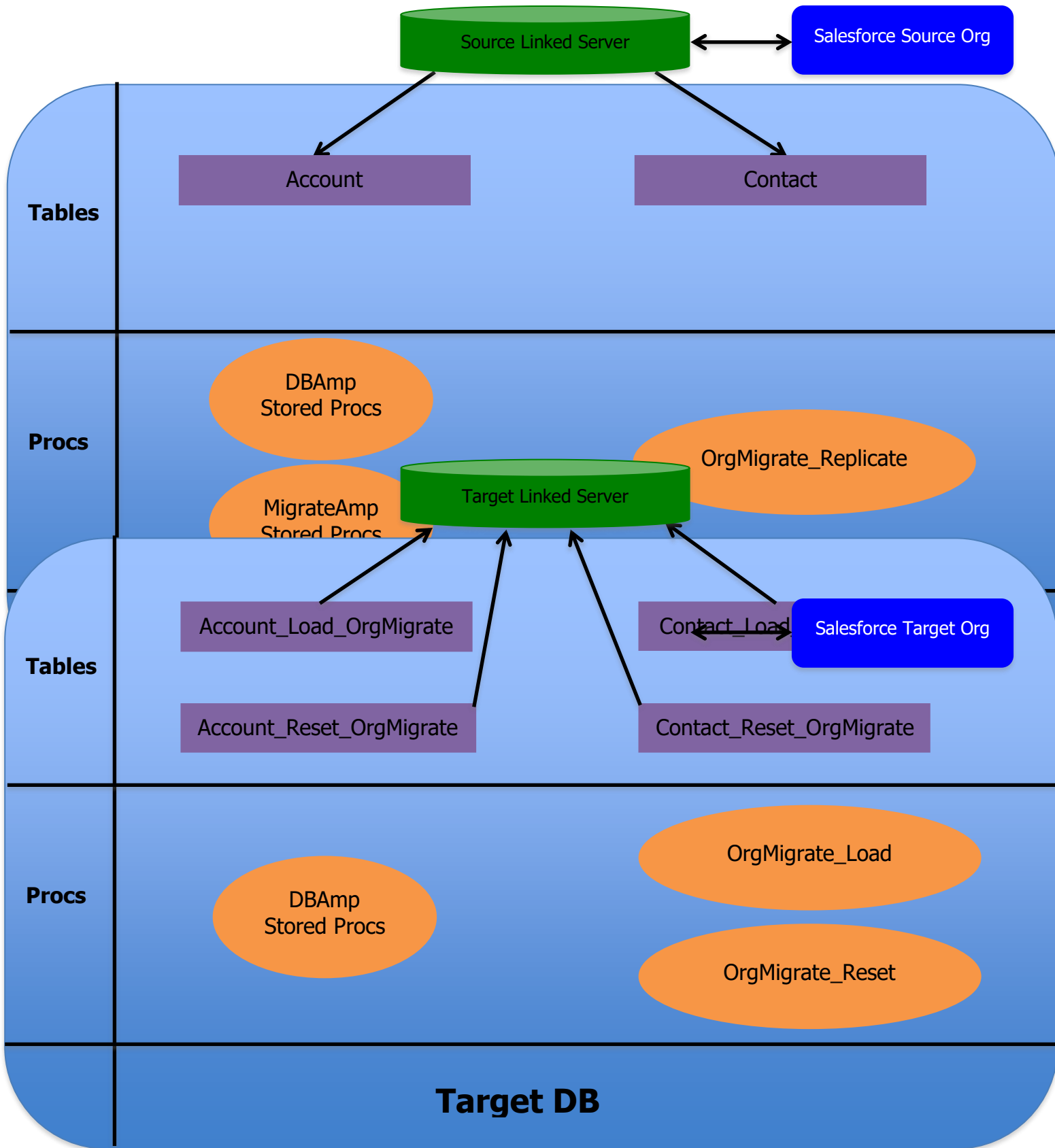

## Chapter 12: Using MigrateAmp

This section describes how to use MigrateAmp and provides an example migration using MigrateAmp.

**Note: MigrateAmp does not support using Person Accounts.**

### Using the SF\_MigrateBuilder Stored Procedures

For MigrateAmp to perform a migration, stored procedures must be created for each step of the migration workflow. To create these stored procedures use the SF\_MigrateBuilder stored procedure. SF\_MigrateBuilder is a stored procedure that creates the three needed stored procedures to perform a migration.

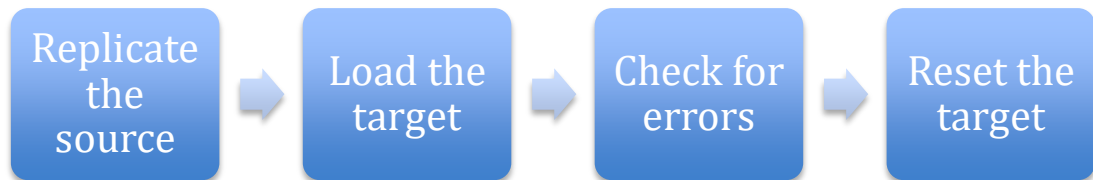

SF\_MigrateBuilder creates a stored procedure to replicate the objects needed for a migration into your source database. SF\_MigrateBuilder creates a stored procedure to load the target org with the records to be migrated. This stored procedure also handles any errors that occurred loading the target org. Lastly, SF\_MigrateBuilder creates a stored procedure to reset the target org.

The three stored procedures created by SF\_MigrateBuilder are used to migrate data from a source org to a target org. The section below provides an example of a migration using SF\_MigrateBuilder.

## Running SF\_MigrateBuilder in User Interface

The following screenshot is of the MigrateAmp User Interface. Click each button to get an in-depth explanation of each step in using the MigrateAmp User Interface.

The screenshot displays the MigrateAmp User Interface, a window titled "MigrateAmp" with standard Windows window controls. The interface is organized into four main sections, each with numbered callouts (1-14) pointing to specific UI elements:

- Connect to SQL:** Contains a text input field for "SQL Server:" and a "Connect to SQL Server" button. Callout 1 points to the button.
- Choose Tables:** Contains several dropdown menus and a button:
  - "Choose a Source DB:" dropdown with callout 2.
  - "Choose a Source Linked Server:" dropdown with callout 3.
  - "Select Key Objects from the Source Instance:" empty list box with callout 4.
  - "Choose a Children Option:" dropdown (set to "None") with callout 5.
  - "Choose a Parent Option:" dropdown (set to "All") with callout 6.
  - "Choose Feature Options:" dropdown with callout 7.
  - "Generate List of Tables" button with callout 8.
- Build Procedures:** Contains dropdown menus and a button:
  - "Choose a Target Linked Server:" dropdown with callout 9.
  - "Choose a Target DB:" dropdown with callout 10.
  - "Enter an Identifier:" text input field with callout 11.
  - "Run SF\_MigrateBuilder" button with callout 12.
- Review Output:** Contains a "Save Output to File" button with callout 13 and a large empty text area with callout 14.

## 1. Connect to SQL Server Button

By clicking the Connect to SQL Server button, a dialog is displayed to connect to a SQL Server instance. Use this button to **connect to the SQL Server instance that is used for DBAmp and MigrateAmp**. You may also use this to connect to your **Source DB**, where the MigrateAmp stored procedures are located.

## 2. Choose a Source DB

Select the database that is being used to replicate the objects down locally in a migration. **The DBAmp and MigrateAmp stored procedures must be located in this database**. If SF\_MigrateBuilder is run, the replicate stored procedure created by SF\_MigrateBuilder will be located in this database.

## 3. Choose a Source Linked Server

Select the linked server connected to your source Salesforce org.

## 4. Select Key Objects from the Source Instance

Select the key objects from your source Salesforce org wanted in a migration. **At least one Key Object** must be selected to run Generate List of Tables or SF\_MigrateBuilder.

## 5. Choose a Children Option

The children option is used to specify which children of the key object(s) to include in a migration. There are three options that can be selected:

1. **All** - includes all required and non-required parents of the key object(s), includes all required and non-required children of the key object(s), and all required parents of the required and non-required children.
2. **Req** - includes all required and non-required parents of the key object(s), includes only the required children of the key object(s), and all required parents of the required children.
3. **None** - includes only all required and non-required parents of the key object(s)

**Note:** The default value is **None**.

## 6. Choose a Parent Option

The parent option is used to specify which parents of the key object(s) to include in a migration. There are two options that can be selected:

1. **All** - includes all required and non-required parents of the key object(s)

2. **Req** - includes only the required parents of the key object(s), does not include the non-required parents of the key object(s)

**Note:** The default value is **All**.

## 7. Choose Feature Options

The features option is used to allow additional objects to be included in a migration. There are three options that can be selected:

1. **Attachments** - includes the Salesforce object(s): Attachment.
2. **Notes** - includes the Salesforce object(s): Note, ContentNote.
3. **Attachments and Notes** – includes the Salesforce object(s) Attachment, Note and ContentNote

Only the feature's records that are associated with the key object(s) are included in a migration.

**Note:** The default value is **Blank**.

## 8. Generate List of Tables Button

The Generate List of Tables button provides statistics and a list of tables in the review output, based on the key objects selected in the Select Key Objects from the Source Instance listbox.

The output generated, is a list of tables, in dependency order, that are included in a migration based on the key object(s) and options selected. This gives you the ability to see which objects are included in a migration before you run SF\_MigrateBuilder.

## 9. Choose a Target Linked Server

Select the linked server connected to your target Salesforce org.

## 10. Choose a Target DB

Select the database used for the migration and deletion of records from your target org. **The DB and stored procedures must be located in this database.** If SF\_MigrateBuilder is run, the load and reset stored procedures created by SF\_MigrateBuilder will be located in this database.

**Note:** The Source database and Target database **MUST** be in the same collation as the system.

## 11. Enter a Name Prefix

Specifies the name being given to the stored procedures that are being created by SF\_MigrateBuilder. The created stored procedure that is replicating the objects locally needed for a migration has \_Replicate appended to the name provided. The created stored procedure that is inserting the records in the target org has \_Load appended to the name

provided. The created stored procedure that is deleting the records from the target org has \_Reset appended to the name provided.

## 12. Run SF\_MigrateBuilder Button

The SF\_MigrateBuilder button is run to create the three stored procedures needed to perform a migration. When this button is run: a replicate stored procedure is created in the Source DB selected, a load stored procedure is created in the Target DB selected, and a reset stored procedure is created in the Target DB selected.

The output from the SF\_MigrateBuilder is provided in the review output box.

**Note:** The three stored procedures created by running SF\_MigrateBuilder **are not executed** in the databases where they are located, they are only **created** in those databases.

## 13. Save Output to File Button

The Save Output to File button is run to save the output in the review output box to a text file.

## 14. Review Output Box

Output from running the Generate List of Tables or SF\_MigrateBuilder button is displayed in this box. Review this output for any errors that occurred.

**Note: SF\_MigrateBuilder only creates the needed stored procedures to complete a migration, it does not execute them. You must navigate to the correct database in SQL Management Studio where these stored procedures were created, and execute them to complete a migration.**

### Running SF\_MigrateBuilder in SQL Management Studio

SF\_MigrateBuilder creates the three stored procedures used to perform a successful migration. In this migration example, we are migrating three key objects (Order, Case, Quote) from the source org to the target org. To do this, a table of key objects needs to be created first:

To create the table of key objects, use the exact syntax provided below. This table **must** be created in your source database.

**Create Table KeyObjects (ObjectName sysname)**

**Insert into KeyObjects (ObjectName) Values ('Order')**

**Insert into KeyObjects (ObjectName) Values ('Case')**

**Insert into KeyObjects (ObjectName) Values ('Quote')**

The created table of key objects should look similar to this:



	ObjectName
1	Order
2	Case
3	Quote

Now you are ready to run SF\_MigrateBuilder.

To run the SF\_MigrateBuilder stored procedure, make sure you are in the **source database**. Use the following commands in Query Analyzer:

**Exec SF\_MigrateBuilder 'KeyObjects', 'Migration1', 'SOURCE', 'TARGET', 'Target DB'**

where *'KeyObjects'* is the name of the table containing the key objects to be migrated, *'Migration1'* is the name given to the stored procedure that is being created by SF\_MigrateBuilder, *'SOURCE'* is the name of the linked server connected to your source org, *'TARGET'* is the name of the linked server connected to your target org, and *'Target DB'* is the name of your target database.

**Note:** Since null was provided for the Options parameter, it is defaulted to Children(None) and no features.

When SF\_MigrateBuilder runs successfully, three new stored procedures are created. The stored procedure used to replicate the objects locally for a migration is located in your **source database**. In your **source database**, there will be a stored procedure similar to the one in the screenshot below:

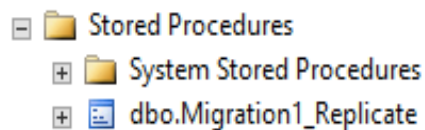

The stored procedures used to migrate the records and delete the records from your target org are located in your **target database**. In your **target database**, there will be two stored procedures similar to the two in the screenshot below:

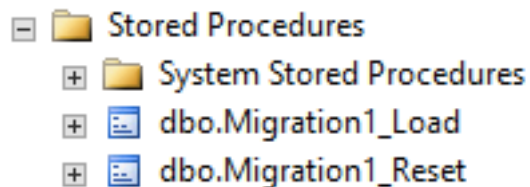

### Replicating the Source org data

The Migration1\_Replicate stored procedure created in your source database is executed to replicate the objects locally that are needed in a migration. To replicate the objects needed for a migration locally, run the stored procedure below.

In your **source database**, run the created stored procedure in Query Analyzer:

#### **Exec Migration1\_Replicate**

where *Migration1\_Replicate* is the name of the replicate stored procedure created by SF\_MigrateBuilder.

### Loading the Target org data

The Migration1\_Load stored procedure created in your target database is executed to migrate records to your target org. To migrate the records needed in a migration to your target org, run the stored procedure below.

In your **target database**, run the created stored procedure in Query Analyzer:

#### **Exec Migration1\_Load**

where *Migration1\_Load* is the name of the load stored procedure created by SF\_MigrateBuilder.

You must review the output of the Migration1\_Load stored procedure to check for errors. Errors can occur for many reasons: validation rule failures, trigger failures, etc.

If errors occur then you need to correct the source data, remove the previously inserted records from the target and rerun the load to the target org. The next section describes the steps to remove the previously inserted target records.

### Resetting the Target org data if needed

The Migration1\_Reset stored procedure created in your target database is executed to delete records out of your target org. This is used to reset the target org once you are finished with a migration or there were errors that occurred during a migration. To delete records out of your target org that were loaded from a single migration, run the stored procedure below.

In your **target database**, run the created stored procedure in Query Analyzer:

#### **Exec Migration1\_Reset**

where *Migration1\_Reset* is the name of the reset stored procedure created by SF\_MigrateBuilder.

By default, the Reset stored procedure only deletes the records that were inserted by the Load stored procedure. If you need to delete **all** records out of your target org, run the stored with the ResetAll parameter set to 'all', in Query Analyzer:

```
Exec Migration1_Reset 'all'
```

where *Migration1\_Reset* is the name of the reset stored procedure created by SF\_MigrateBuilder, and 'all' is the keyword used in the reset script to reset all records in the target org

### **An in-depth look at the SF\_MigrateBuilder Parameters**

SF\_MigrateBuilder takes six parameters. This section will detail each of the six parameters in their order for SF\_MigrateBuilder.

#### **KeyObjectTable Parameter**

Specifies what key objects to be migrated from your source org to your target org. This parameter can either be a single key object or a table of key objects.

**Example:** To migrate only a single key object, Account, run the command below in your **source database**.

```
Exec SF_MigrateBuilder 'Account', 'MigrateAcct', 'SOURCE',  
'TARGET', 'Target DB'
```

where '*Account*' is the single key object to be migrated, '*MigrateAcct*' is the name given for the created stored procedures, '*SOURCE*' is the name of the linked server connected to your source Salesforce org, '*TARGET*' is the name of the linked server connected to your target Salesforce org, and '*Target DB*' is the name of the target database you created.

**Example:** To migrate multiple key objects, follow the steps below.

To migrate multiple key objects, a table must be constructed for the key objects:

#### **Create Table KeyObjects**

**(ObjectName sysname)**

**You must create the table as shown above for the migration to work properly. The name of the table can be named whatever is deemed necessary.**

The table above is then populated with the key objects that need to be migrated.

In your source database, run the following command to migrate the table of key objects:

```
Exec SF_MigrateBuilder 'KeyObjects', 'MigrateKeyObjects',  
'SOURCE', 'TARGET', 'Target DB'
```

where *'KeyObjects'* is the table containing the key objects to be migrated, *'MigrateKeyObjects'* is the name given for the created stored procedures, *'SOURCE'* is the name of the linked server connected to your source Salesforce org, *'TARGET'* is the name of the linked server connected to your target Salesforce org, and *'Target DB'* is the name of the target database you created.

### **Identifier Parameter**

Specifies the name being given to the stored procedures that are being created by SF\_MigrateBuilder. The created stored procedure that is replicating the objects locally needed for a migration has *\_Replicate* appended to the name provided in this parameter. The created stored procedure that is inserting the records in the target org has *\_Load* appended to the name provided in this parameter. The created stored procedure that is deleting the records from the target org has *\_Reset* appended to the name provided in this parameter.

### **SourceLinkedServer Parameter**

Specifies the linked server connected to your source Salesforce org.

### **TargetLinkedServer Parameter**

Specifies the linked server connected to your target Salesforce org.

### **Target Database Parameter**

Specifies the target database used for the migration and deletion of records from your target org.

**Note:** The Source database and Target database **MUST** be in the same collation as the system.

### **Options Parameter**

Specifies the children of the key object(s) and the features to be included in a migration. To specify the children objects to include in a migration, the key word **Children** is used in the parameter. To choose the features wanted in a migration, the key word **Features** is used in the parameter. To specify the parent objects to include in a migration, the key word **Parents** is used in the parameter.

#### **Children**

Children is a key word used in the Options parameter to specify which children of the key object(s) to include in a migration. There are three options that can be used with children:

- 4. Children(All)-** includes all required and non-required parents of the key object(s), includes all required and non-required children of the key object(s), and all required parents of the required and non-required children.

5. **Children(Req)**- includes all required and non-required parents of the key object(s), includes only the required children of the key object(s), and all required parents of the required children.
6. **Children(None)**- includes only all required and non-required parents of the key object(s)

**Note:** The default value is **Children(None)**. Only one of **All, Req, or None** is permitted for the Options parameter.

### Features

Features is a key word used in the Options parameter to allow additional objects to be included in a migration. There are several options that can be used to include features:

4. **Features(A)**: includes the Salesforce object(s): Attachment.
5. **Features(N)**: includes the Salesforce object(s): Note, ContentNote.

### Notes

Any combination of A or N can be used for features. Only the feature's records that are associated with the key object(s) are included in a migration.

### Parents

Parents is a key word used in the Options parameter to specify which parents of the key object(s) to include in a migration. There are two options that can be used with parents:

3. **Parents(All)**- includes all required and non-required parents of the key object(s)
4. **Parents(Req)**- includes only the required parents of the key object(s), does not include the non-required parents of the key object(s)

**Note:** The default value is **Parents(All)**. Only one of **All or Req** is permitted for the Options parameter.

### Example

Children, features, and parents can be used at the same time in the Options parameter. For example, to include only required children, include attachments, and include only the required parents in a migration, run the query below in your **source database**:

```
Exec SF_MigrateBuilder 'KeyObjects', 'Migration1', 'SOURCE',  
'TARGET', 'Target DB', 'Children(Req), Features(A), Parents(Req)'
```

## Passing Parameters to `_Load Stored Procedure`

The `_Load` stored procedure that is created by `SF_MigrateBuilder` takes a parameter called `KeyObjectIds`. This section details the `KeyObjectIds`, and provides an example using this parameter.

The `KeyObjectIds` parameter specifies what source key object Ids to include in a migration. Instead of including all records of a key object, this parameter allows you to specify particular records of a key object. To do so, create a table that contains the specific source key object Ids wanted for a migration. Using this parameter will only include the key object Ids specified and the records from other objects associated with those key object Ids for a migration.

This parameter takes a table that contains the source key object Ids needed for a migration. The table is created in your **source database**. The stored procedure used for loading the target org that was created in your target database by `SF_MigrateBuilder` takes the `KeyObjectIds` parameter.

In your **source database**, create the table used for this parameter, by following the instructions below:

### Create Table `KeyObjectIds (ObjectIds nchar(18))`

**You must create the table as shown above for the migration to work properly. The name of the table can be named whatever is deemed necessary.**

Populate the created table above with the key object primary key Ids needed to be migrated.

This table is provided for the `KeyObjectIds` parameter of the `_Load` stored procedure in your target database used to migrate records to your target org.

For example, to migrate only certain records of the key objects in the `KeyObjects` table and their associated records from other objects in the migration, run the following query:

```
Exec Migration1_Load 'KeyObjectIds'
```

where `Migration1_Load` is the name of the load stored procedure created by `SF_MigrateBuilder`, and `'KeyObjectIds'` is the name of the table with the specific records of the key object(s) to migrate.

## Migrating Salesforce CRM Content

Migrating Salesforce CRM Content is a **separate migration** from all other migrations, do **not** migrate Salesforce CRM Content with any other objects.

To migrate Salesforce CRM Content, follow the instructions below:

**Note:** The Max Base64 Field Size must be set to a number large enough to handle the CRM Content being migrated. To modify the Max Base64 Field

Size, run the DBAmp Configuration Program on the server, go to Configuration/Registry Settings.

In your **source database**, run the following SF\_MigrateBuilder to create the stored procedures needed to migrate CRM Content:

```
Exec SF_MigrateBuilder 'ContentWorkspaceDoc',  
'ContentWorkspaceDoc', 'SOURCE', 'TARGET', 'Target DB'
```

**Note:** You must use **ContentWorkspaceDoc** as the **key object** in order to migrate Salesforce CRM Content.

Once the SF\_MigrateBuilder command above is executed, three stored procedures are created: **ContentWorkspaceDoc\_Replicate**, **ContentWrokspaceDoc\_Load**, and **ContentWorkspaceDoc\_Reset**.

Use the **ContentWorkspaceDoc\_Replicate** stored procedure to replicate the tables needed to migrate CRM Content locally. To do this, run the query below in your **source database**:

```
Exec ContentWorkspaceDoc_Replicate
```

Now, use the **ContentWrokspaceDoc\_Load** stored procedure to load the target org. To do this, run the query below in your **target database**:

```
Exec ContentWorkspaceDoc_Load
```

Finally, use the **ContentWorkspaceDoc\_Reset** stored procedure to reset the target org if any errors occur. To do this, run the query below in your **target database**:

```
Exec ContentWorkspaceDoc_Reset 'all'
```

**Note: Any CRM Content in a private library or private to a user cannot be migrated. If users want them to be preserved during a migration, they have to move them to a public folder first.**

### **Migrating Salesforce Knowledge**

Migrating Salesforce Knowledge is a **separate migration** from all other migrations, do **not** migrate Salesforce Knowledge with any other objects.

When migrating Knowledge, you have to migrate via the **ArticleType\_\_kav** tables. **ArticleType** is the name of the article's type. All articles in Knowledge are assigned to an *article type* (ex- FAQ, Newsletter, Offer, etc.). An article's type determines the type of content it contains, its appearance, and which users can access it.

**Note:** MigrateAmp only migrates articles that are **published**. It does **not** migrate articles that are **drafts** or articles that have been **archived**. **All Article Types must be created prior** to the migration on the **target** Salesforce org so that they **match** the Article Types on the **source** Salesforce org.

Articles can also be in different languages. MigrateAmp only migrates the articles in the **Master Language**. Articles translated into different languages from the Master Language, are **not** included in the migration.

**Note:** The migrated Knowledge Articles on the target org are all created as **Draft Articles**. This is a Salesforce restriction. Therefore, you have to **manually** publish and submit translations for the Articles, up on your target org.

Knowledge contains a concept called **data categories**. Data categories allow users to classify records, find records, and control access to records. Data categories are included in a migration via the **ArticleType\_\_DataCategorySelection** tables. Any **ArticleType\_\_kav** tables being migrated will include the **\_\_DataCategorySelection** table for each of the **\_\_kav** tables being migrated.

**Note:** All data categories must be **created prior** to the migration on the **target** org so that they **match** the data categories on the **source** org. Also, the matching data categories must be **active** on **both** orgs.

For further information on Salesforce Knowledge, visit the following link:  
[https://developer.salesforce.com/docs/atlas.en-us.api.meta/api/sforce\\_api\\_guidelines\\_knowledge.htm](https://developer.salesforce.com/docs/atlas.en-us.api.meta/api/sforce_api_guidelines_knowledge.htm)

### **Migrating Single Salesforce Knowledge Article Type**

To migrate just the **FAQ Salesforce Knowledge Article Type**, follow the instructions below:

In your **source database**, run the following SF\_MigrateBuilder to create the stored procedures needed to migrate FAQ Salesforce Knowledge:

```
Exec SF_MigrateBuilder 'FAQ__kav', 'FAQ', 'SOURCE', 'TARGET', 'Target DB'
```

Where **FAQ\_\_kav** is the name of the article type table to be migrated.

**Note:** **\_\_kav** must be **appended** to the end of the article type table to be migrated.

Once the SF\_MigrateBuilder command above is executed, three stored procedures are created: **FAQ\_Replicate**, **FAQ\_Load**, and **FAQ\_Reset**.

Use the **FAQ\_Replicate** stored procedure to replicate the tables needed to migrate the FAQ Article Type locally. To do this, run the query below in your **source database**:

```
Exec FAQ_Replicate
```

Now, use the **FAQ\_Load** stored procedure to load the target org. To do this, run the query below in your **target database**:

```
Exec FAQ_Load
```



Finally, use the **FAQ\_Reset** stored procedure to reset the target org if any errors occur. To do this, run the query below in your **target database**:

**Exec FAQ\_Reset 'all'**

### **Migrating Multiple Salesforce Knowledge Article Types**

To migrate **multiple Salesforce Knowledge Article Types**, follow the instructions below:

In this migration, there are four article types being migrated: FAQ, Newsletter, Offer, and Notice.

In your **source database**, create the table to hold the article types you want to migrate:

**Create Table ListOfKAVTables (ObjectName sysname)**

**Insert into ListOfKAVTables (ObjectName) Values ('faq\_\_kav')**

**Insert into ListOfKAVTables (ObjectName) Values ('newsletter\_\_kav')**

**Insert into ListOfKAVTables (ObjectName) Values ('offer\_\_kav')**

**Insert into ListOfKAVTables (ObjectName) Values ('notice\_\_kav')**

The created table of article types to be migrated should look similar to this:

	ObjectName
1	faq__kav
2	newsletter__kav
3	offer__kav
4	notice__kav

In your **source database**, run the following SF\_MigrateBuilder to create the stored procedures needed to migrate multiple Knowledge Article Types:

**Exec SF\_MigrateBuilder 'ListOfKAVTables', 'ListOfKAVTables', 'SOURCE', 'TARGET', 'Target DB'**

Once the SF\_MigrateBuilder command above is executed, three stored procedures are created: **ListOfKAVTables\_Replicate**, **ListOfKAVTables\_Load**, and **ListOfKAVTables\_Reset**.

Use the **ListOfKAVTables\_Replicate** stored procedure to replicate the tables needed to migrate multiple Article Types locally. To do this, run the query below in your **source database**:

**Exec ListOfKAVTables\_Replicate**

Now, use the **ListOfKAVTables \_Load** stored procedure to load the target org. To do this, run the query below in your **target database**:

**Exec ListOfKAVTables \_Load**

Finally, use the **ListOfKAVTables \_Reset** stored procedure to reset the target org if any errors occur. To do this, run the query below in your **target database**:

**Exec ListOfKAVTables \_Reset 'all'**

### **Associating Knowledge Articles with Cases**

By default, knowledge articles and cases are not associated automatically in the target org after they have been migrated. Before knowledge articles can be associated with cases, the following steps must be completed:

1. The Case object must be migrated over to the target org, with a SourceId custom field on the target org Case object. **Therefore, you must have a SourceId\_\_c column on the target Case object.**
2. The knowledge article types that you want to associate with cases must be migrated over to the target (i.e. faq\_\_kav, knowledge\_\_kav, newsletter\_\_kav, etc.)

Now you are ready to run the SF\_PopulateCaseArticle stored procedure to associate knowledge articles with cases. SF\_PopulateCaseArticle is located in the CREATE DBAmp SPROCS script. This stored procedure **must be executed in the target database**.

To associate knowledge articles with cases, execute the SF\_PopulateCaseArticle stored procedure with the correct parameters in the target database:

**exec SF\_PopulateCaseArticle 'SOURCE', 'TARGET', 'Source DB'**

where '*SOURCE*' is the name of the linked server connected to your source org, '*TARGET*' is the name of the linked server connected to your target org, and '*Source DB*' is the name of your source database.

### **Frequently Asked Questions**

**I want attachments in my migration. Which attachments are included in a migration and how do I include them?**

Attachments whose parent is a key object are the only attachments included in a migration. Therefore, if Account is the key object in a migration, only the attachments associated with the Accounts in a migration are included.

In order to include attachments in a migration, use the options parameter of SF\_MigrateBuilder. In the options parameter, use the features keyword and the 'a' key letter to include attachments. Either children(all) must be used with the features keyword in order to include features or the children

keyword must not be specified in the options parameter. The two ways to include attachments in a migration are shown below:

```
exec SF_MigrateBuilder 'Account', 'Account', 'SOURCE', 'TARGET', 'Target  
DB', 'children(all), features(a)'
```

```
exec SF_MigrateBuilder 'Account', 'Account', 'SOURCE', 'TARGET', 'Target  
DB', 'features(a)'
```

Either syntax above includes attachments related to the Accounts in a migration when Account is the Key Object.

**Some foreign keys of the migrated objects are null even though the object the key points to is a table of the migration.**

All required relationship foreign keys should have the correct value for all tables in the migration.

All non-required relationship foreign keys of key objects should have a value. Non-required relationships on objects that are NOT key objects are not populated. If you have an object that is affected by this rule, consider making that object a key object of the migration.

## Chapter 13: Viewing a Migration Database Diagram

The SF\_MigrateGraphML stored procedure produces a script that is imported into the visualization software, yED Graph Editor. SF\_MigrateGraphML is used to produce a database diagram using yED. SF\_MigrateGraphML is executed in your **source database**, which produces a script in the messages upon execution. The section below will walk through using SF\_MigrateGraphML.

To view a database diagram of a migration, you must download the software, yED Graph Editor, on your machine. To download yEd Graph Editor, follow the instructions at the following link:

[http://www.yworks.com/en/products\\_yed\\_download.html](http://www.yworks.com/en/products_yed_download.html)

Once you have downloaded yED Graph Editor, you are now ready to view a database diagram for a migration. The steps for creating a database diagram using yED are presented below:

1. Run the SF\_MigrateGraphML stored procedure in your source database. To run the SF\_MigrateGraphML stored procedure, use the following commands in Query Analyzer:

### Exec SF\_MigrateGraphML 'KeyObjects', 'Migration1', 'SOURCE'

An XML script is produced in the messages of the executed stored procedure.

2. Copy the XML script. The XML script should look similar to the screenshot below:

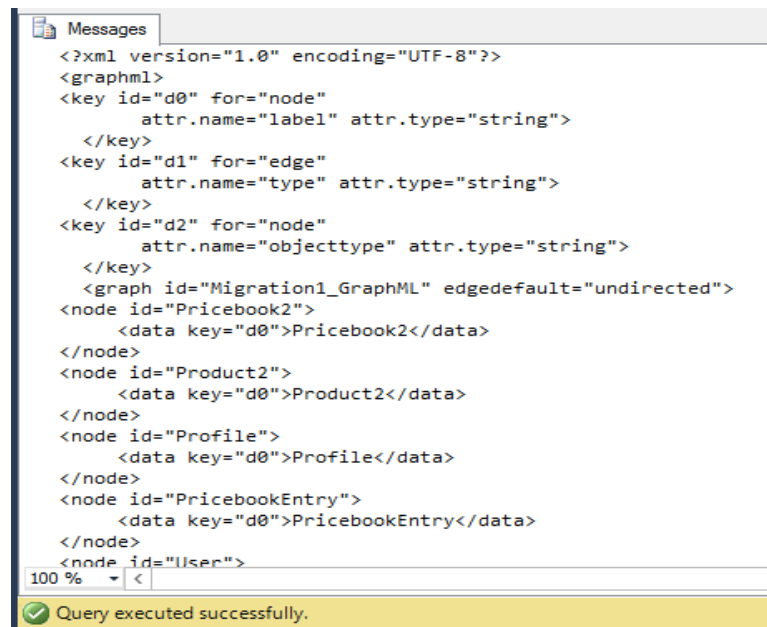

```
Messages
<?xml version="1.0" encoding="UTF-8"?>
<graphml>
<key id="d0" for="node"
  attr.name="label" attr.type="string">
  </key>
<key id="d1" for="edge"
  attr.name="type" attr.type="string">
  </key>
<key id="d2" for="node"
  attr.name="objecttype" attr.type="string">
  </key>
<graph id="Migration1_GraphML" edgedefault="undirected">
<node id="Pricebook2">
  <data key="d0">Pricebook2</data>
</node>
<node id="Product2">
  <data key="d0">Product2</data>
</node>
<node id="Profile">
  <data key="d0">Profile</data>
</node>
<node id="PricebookEntry">
  <data key="d0">PricebookEntry</data>
</node>
<node id="User">
```

100 % <

Query executed successfully.

3. Paste

the XML script into a notepad.

4. Save the XML script in the notepad as all files and append .graphml to the end of the name you save it as. Save it in your documents folder. A Screenshot of this is shown below:

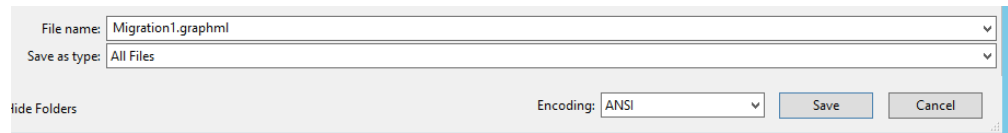

5. Open the saved XML script in yED Graph Editor. Go to File/Open and navigate to your saved XML script.
6. Navigate to Edit/Properties Manager to edit the node and edge options for the diagram. The Properties Manager page is shown in the screenshot below:

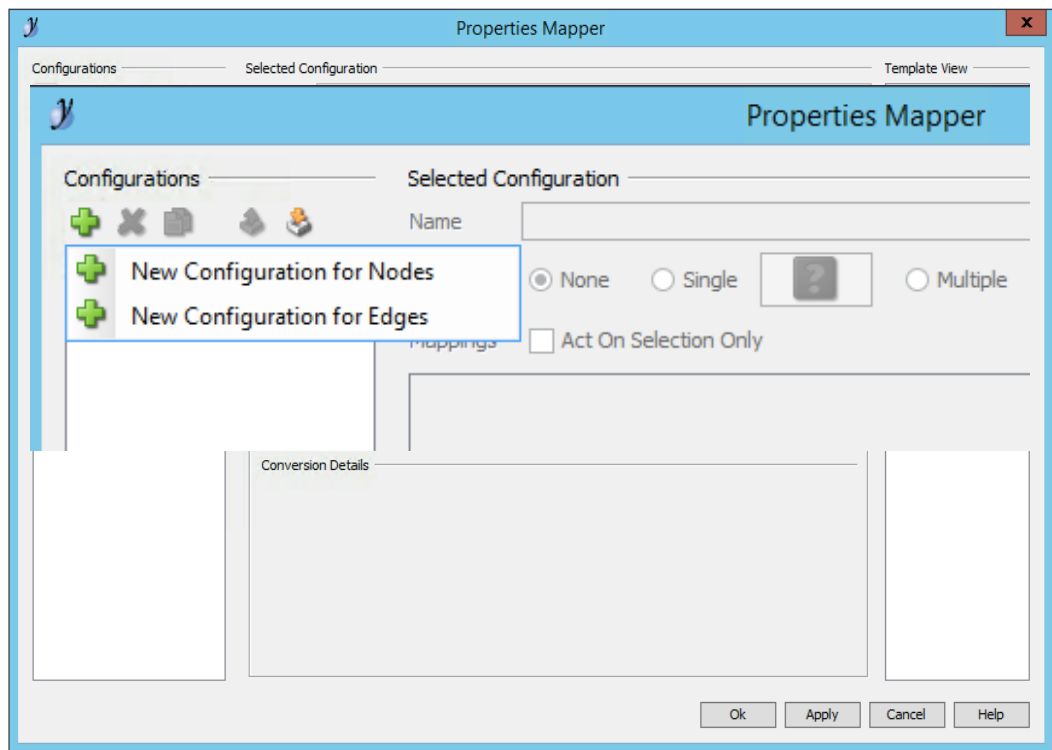

7. Under the Configurations section of Properties Manager, click the green plus sign and select **New Configuration for Nodes**.

- Under the Selected Configuration section of Properties Manager, click the green plus sign twice. Under one Data Source, change label to objecttype. Under Map To, change Label Text to Fill Color. Under Conversion, change Automatic to Distinct Values.

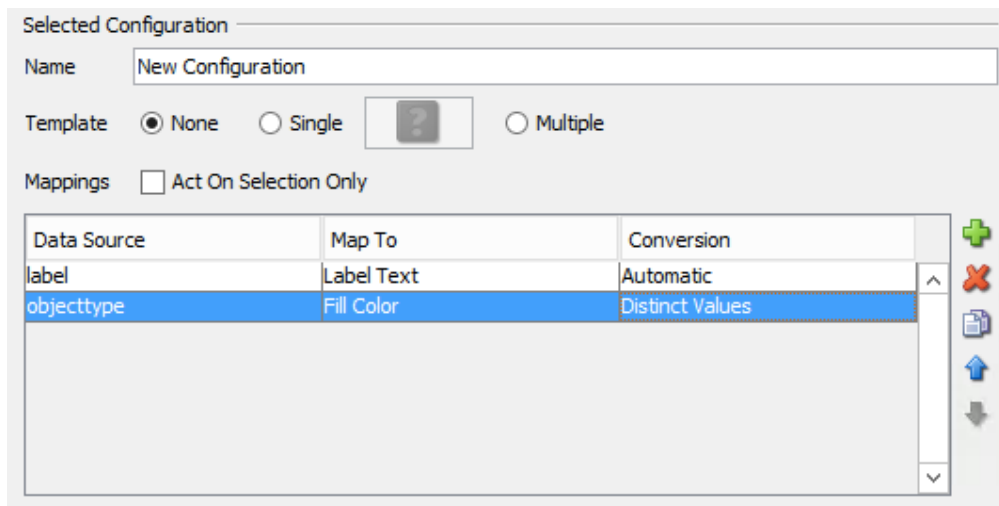

- Under the Selected Mapping section of Properties Manager, click the green plus sign. For objecttype, select KeyObject. For Fill Color, select green.

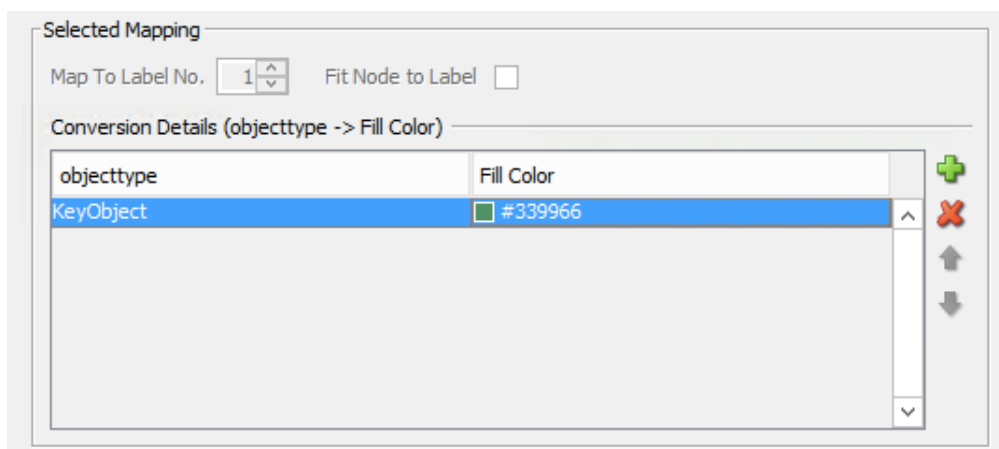

- Click Apply, to apply these changes.
- Under the Configurations section of Properties Manager, click the green plus sign and select **New Configuration for Edges**.

- Under the Selected Configuration section of Properties Manager, click the green plus sign twice. Under Map To, change one Map To to Line Type. Change the other Map To to Line Color. Under Conversion, change both to Distinct Values.

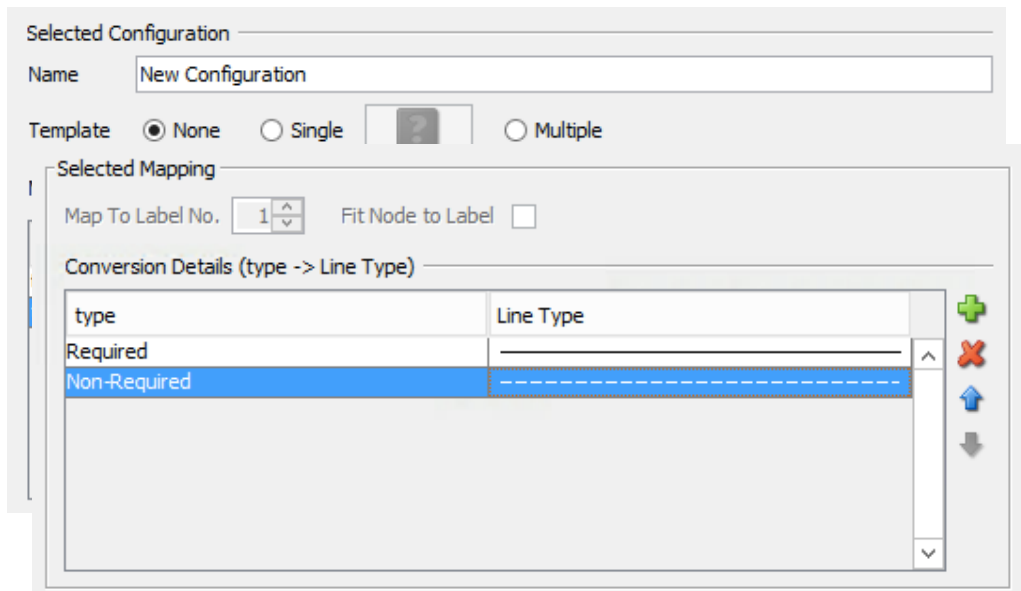

- With type that is mapping to Line Type highlighted, click the green plus sign twice under the Selected Mapping section of Properties Manager. For Required, select a solid Line Type. For Non-Required, select a dotted Line Type.

- With type that is mapping to Line Color highlighted, click the green plus sign twice under the Selected Mapping section of Properties Manager. For Required, select a blue Line Color. For Non-Required, select a red Line Color.

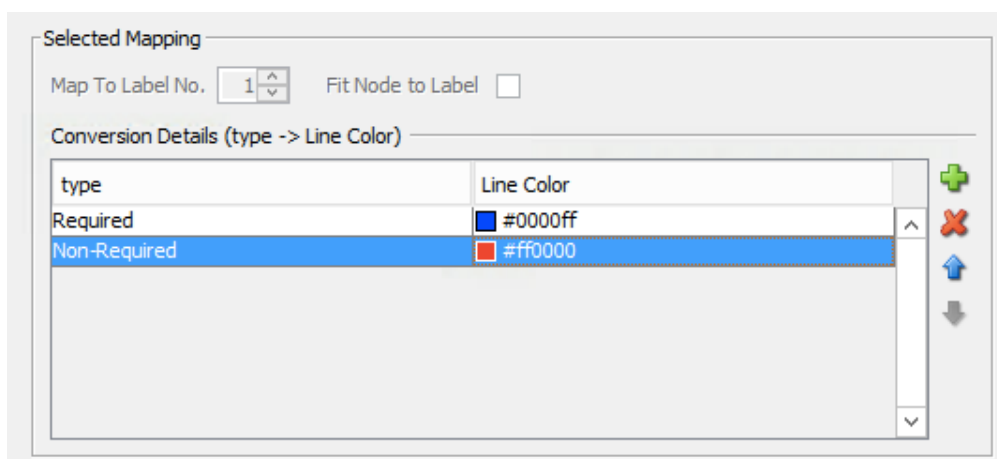

- Click Apply, to apply these changes. Then, click OK.

16. Navigate to Layout/Hierarchical. Make sure the Orientation is set to Bottom to Top. Click OK.

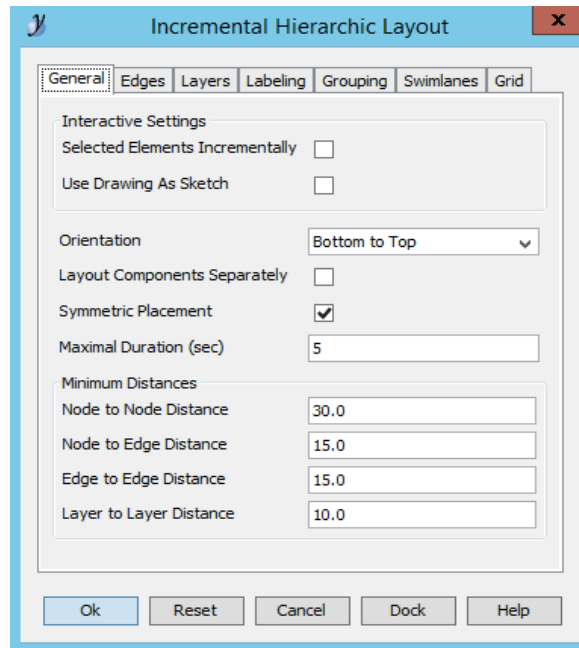



17. The Database Diagram should look similar to the screenshot below:

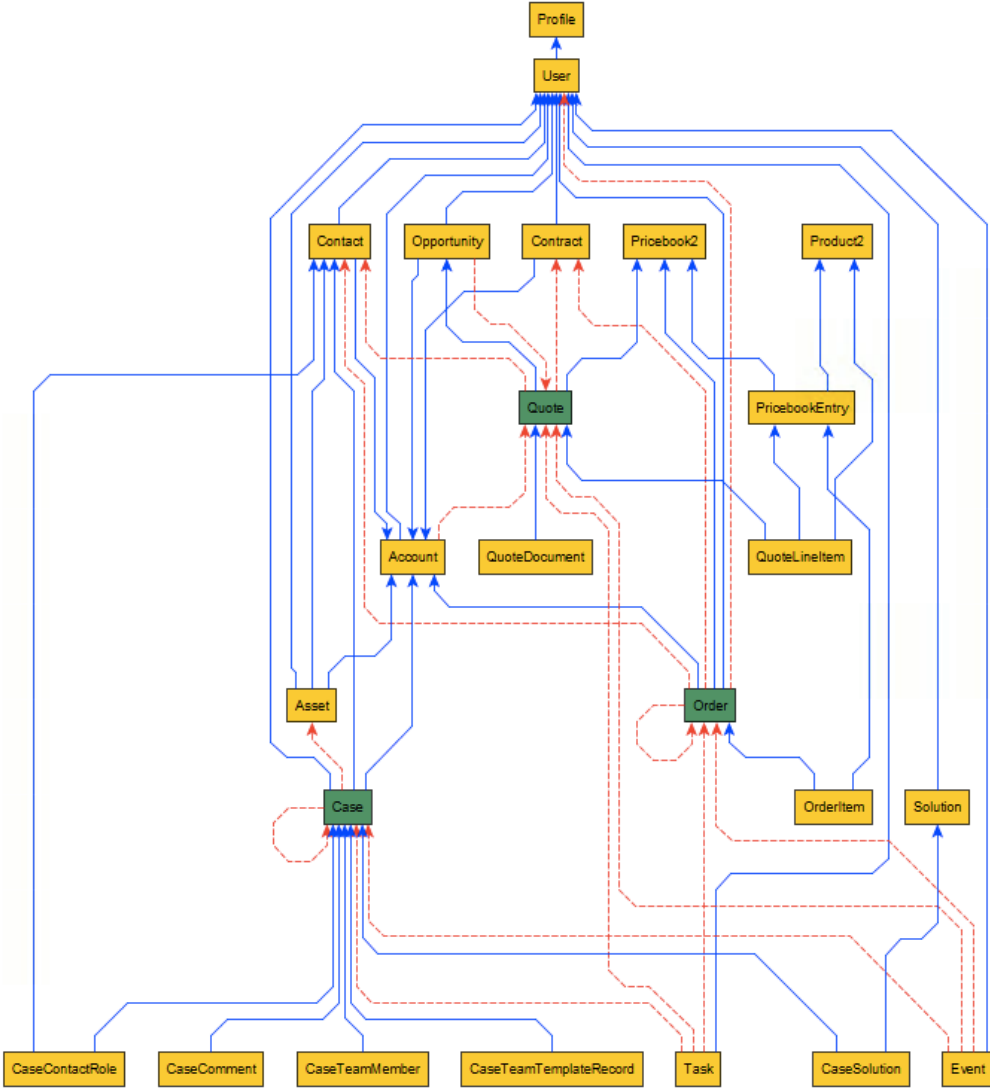

## Chapter 14: DBAmp Client

### Why DBAmp Client?

#### Advantages of using the DBAmp Client:

- XP\_CmdShell not being enabled on the SQL Server machine prevents some DBAmp stored procedures from being used. DBAmp Client enables these DBAmp stored procedures to be run on a client machine as opposed to on the actual SQL Server machine.
- DBAmp Client provides a user interface to help with parameter construction for DBAmpAZ.
- Command lines constructed by DBAmp Client can be copied and pasted to CmdExec steps in SSIS or SQL Job Steps.

#### Architecture of the DBAmp Client:

- DBAmp Client connects to a SQL Server machine with a DBAmp linked server. Therefore, the full DBAmp package must be installed on the SQL Server machine that the DBAmp Client is connecting to.
- The DBAmp Client must be able to connect to the remote SQL Server machine using SQL Native Client.
- Salesforce credentials are not stored on the client machine where DBAmp Client is running.
- The DBAmp linked server chosen in the DBAmp Client user interface is used for obtaining the Salesforce credentials.
- The Work and Blob Directories are located on the client machine as opposed to the SQL Server machine.

Below is a diagram showing the DBAmp Client architecture:

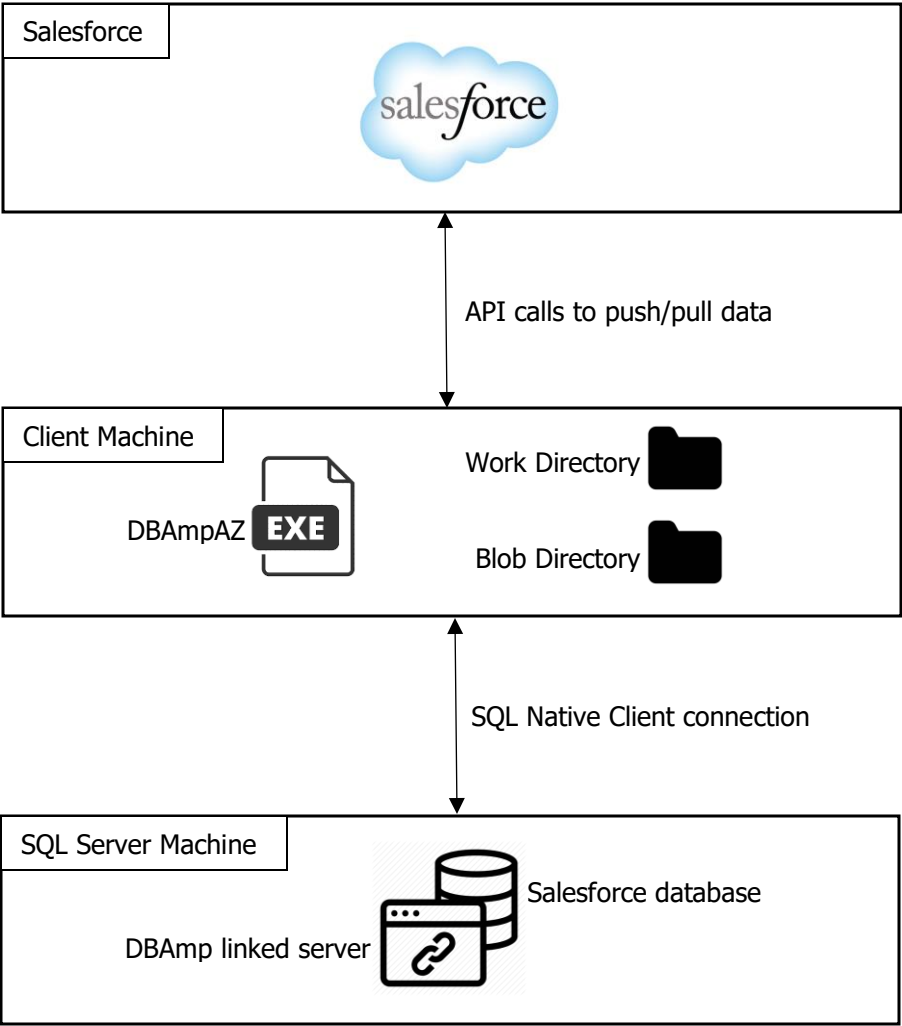

**Installing DBAmp Client**

To successfully install and use DBAmp Client, follow the instructions below.

**Installing the DBAmp Client User Interface:**

1. On the Client machine, download the dbampclient.zip file using the download link on this page: <http://www.forceamp.com/hats/dbampclient.zip>
2. To install the DBAmp Client User Interface, unzip the DBAmpClient package to a temporary directory. Run the DBAmpClientInstall.exe program. Setup will prompt you for the DBAmp program directory and install the software.

## Running the DBAmp Client

The following screenshots are of the DBAmp Client User Interface and each of its sections. Click each button to get an in-depth explanation of each step in using the DBAmp Client User Interface.

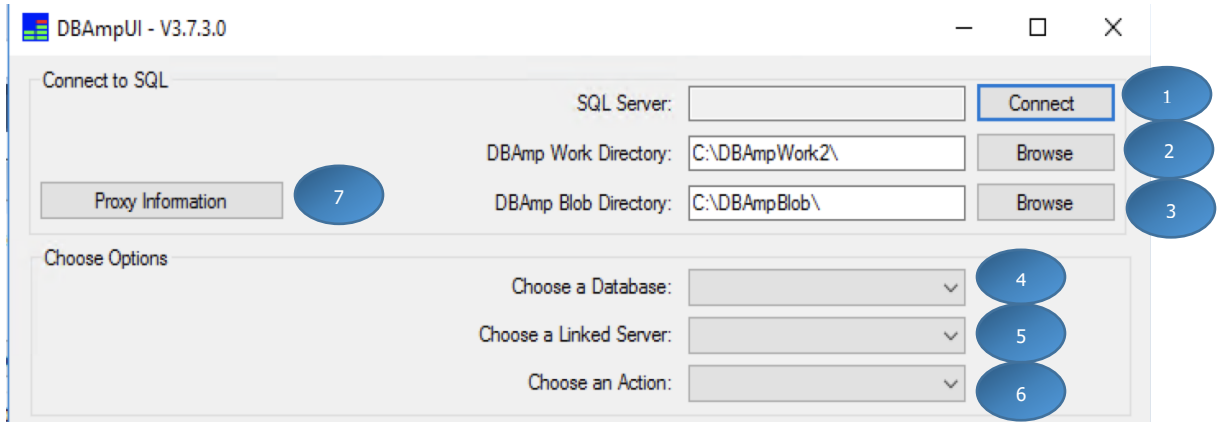

### 1. Connect to SQL Server Button

By clicking the Connect to SQL Server button, a dialog is displayed to connect to a SQL Server instance. Use this button to **connect to the SQL Server instance that is used for DBAmp**. You may also use this to connect to your salesforce database, where the DBAmp stored procedures are located.

### 2. DBAmp Work Directory

The DBAmp Work Directory holds the work files produced by the SF\_Mirror and SF\_TableLoader stored procedures when using the **BulkAPI or PKChunk options**. Use the browse button to create, find and set the work directory. Make sure the directory is on a drive with enough space. Large downloads will expand the size of this directory dramatically.

### 3. DBAmp Blob Directory

The DBAmp Blob Directory is a local directory that holds downloaded files containing the binary field(s) content of a Salesforce object. The downloaded files are produced by the SF\_DownloadBlobs stored procedure. Use the browse button to create, find and set the blob directory. Make sure the directory is on a drive with enough space. Large downloads will expand the size of this directory dramatically.

### 4. Choose a Database

Select the database that is being used to push and pull Salesforce data. **The DBAmp stored procedures must be located in this database.**

### 5. Choose a Linked Server

Select the linked server connected to your Salesforce Org.

## 6. Choose an Action

Select the action for the DBAmp Client to perform. Actions include: Mirror, TableLoader, and DownloadBlobs.

## 7. Proxy Information Button

By clicking the Proxy Information button, a dialog is displayed to enter proxy information.

### Performing a Mirror Action

The Mirror action is the equivalent of the SF\_Mirror stored procedure.

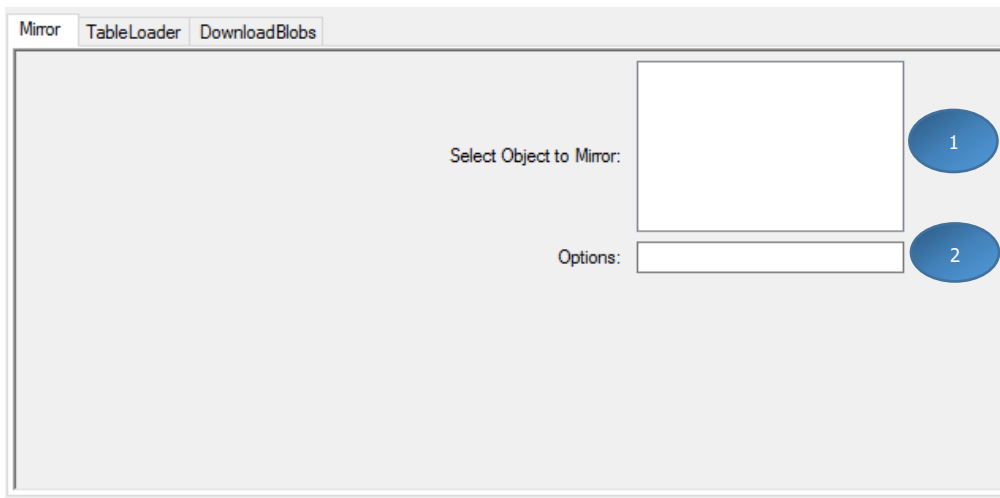

The screenshot shows a dialog window with three tabs: "Mirror", "TableLoader", and "DownloadBlobs". The "Mirror" tab is selected. Inside the dialog, there is a label "Select Object to Mirror:" followed by a large empty text box. Below this is a label "Options:" followed by a smaller empty text box. Two blue circular callouts are present: callout "1" points to the "Select Object to Mirror:" text box, and callout "2" points to the "Options:" text box.

### 1. Select a Salesforce Object

Select a Salesforce object to be mirrored locally.

### 2. Options

Enter any options that are valid for the SF\_Mirror stored procedure. For more information on what options are valid, see the **SF\_Mirror** section in **Chapter 7**.

## **Performing a TableLoader Action**

The TableLoader action is the equivalent of the SF\_TableLoader stored procedure.

Mirror TableLoader DownloadBlobs

Select a SQL Input Table:

Choose an Operation:

Choose an External Id:

Options:

### **1. Select a SQL Input Table**

Select the SQL table that contains the data to push to Salesforce.

### **2. Choose an Operation**

Choose the Salesforce operation to push the data up to Salesforce with. Operations include: Insert, Update, Delete, Upsert, UnDelete, HardDelete, and ConvertLead.

### **3. Choose an External Id**

Choose the external Id to use when using the upsert operation. **Note: must choose an external Id when using the upsert operation.**

### **4. Options**

Enter any options that can be specified for the SF\_TableLoader stored procedure. For more information on what options are valid, see the **SF\_TableLoader** section in **Chapter 7**.

## **Performing a DownloadBlobs Action**

The DownloadBlobs action is the equivalent of the SF\_DownloadBlobs stored procedure.

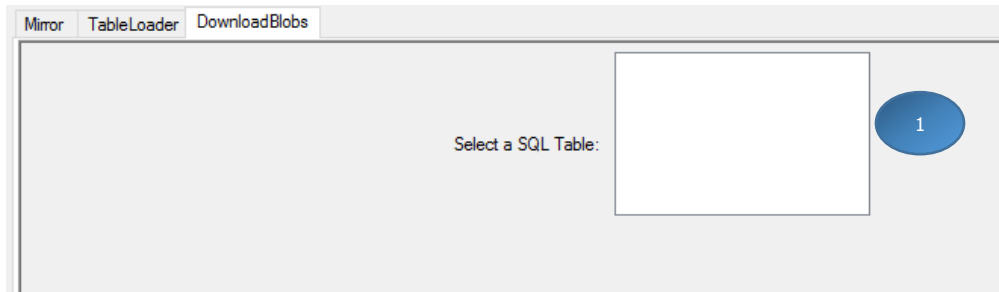

### **1. Select a SQL Table**

Select the SQL table that contains the Ids of the binary files(s) to download locally into the Blob Directory.

## **Previewing Output**

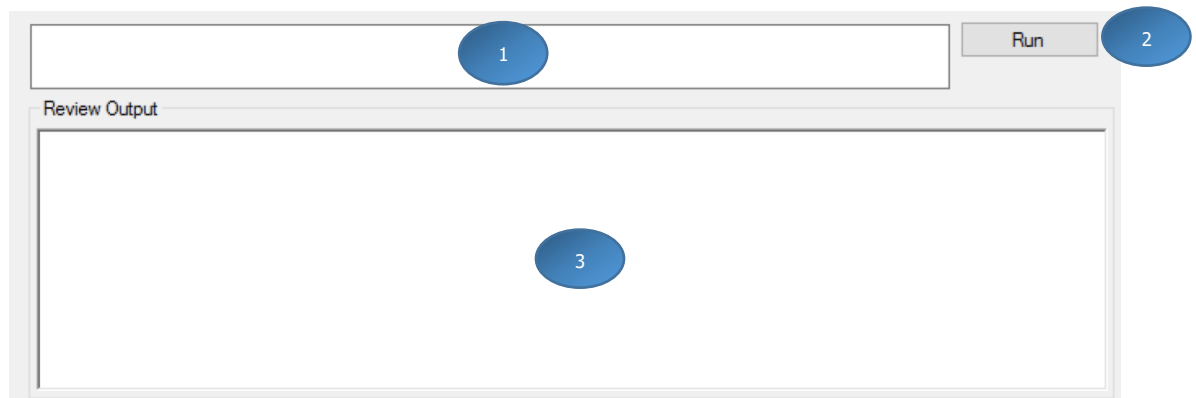

### **1. Command Output Window**

Displays the command based on the options selected above. The command can be copied and used in a CmdExec of a SQL job.

### **2. Run Button**

Click this button to run the command displayed in the command output window. The command is run on the SQL instance and in the database chosen above.

### **3. Review Output Window**

Displays the complete message output from the DBAmp command being run in the command output window.