

AN OVERVIEW OF THERMODYNAMICS

In this chapter thermodynamics will be examined from a broad philosophical perspective after a brief discussion of philosophy, mathematics, and the nature and methods of science. The object will be to understand the rationale of thermodynamics and to show how it fits into the scientific scheme of things.

1.1 PHILOSOPHY

Today, philosophy is generally regarded as one among many intellectual disciplines. Any respectable university will have a curriculum identified as philosophy which will contain subareas such as ethics, aesthetics, logic, and perhaps metaphysics. In the long history of philosophy, this compartmentalization is a fairly recent development, for since the Greeks first began to philosophize, philosophy was not a formal subject but rather an intellectual attitude. Along these lines, one of today's better known philosophers, Richard Rorty, defines the task of philosophy not as discovering absolute truth, but "keeping the conversation going". Yet, as the story of Socrates reminds us, sometimes the conversation can be quite unsettling especially when cherished customs and beliefs are the topic. The Athenians undeniably overreacted, but their resentment is understandable for it seemed that Socrates reminded them that the truth on which they had built their stately institutions and cherished beliefs was not bedrock but swampy ground. Moreover, he seemed to revel in exposing this flaw and showed no interest in the arduous task of draining the swamp. Taking him seriously, the Athenians regarded Socrates as subversive and punished him accordingly.

In any event, after centuries of serious philosophical thought, it does appear that the swamp can not be drained; we can never reach the bedrock of absolute truth on which to erect our structure of knowledge. While conceding this state of affairs, many modern-day philosophers adopt a more pragmatic approach and recommend a systematic program of rational thought, as exemplified by science, as a means of drawing ever closer to the truth. Thus, Karl Popper, an eminent philosopher of science, advocates the scientific method not just because it brings us closer to truth, but also because it suggests new and fruitful questions. Asking the proper questions is important because it is a truism that Nature answers only the question asked. In other words, the questioner provides the context for the response.

Questions concerning truth and knowledge belong in the province of epistemology, a branch of metaphysics sometimes known as the theory of knowledge. Other metaphysical subjects are reality and the nature of being. Any discussion of these questions usually leads to deeper questions such as *What is the nature of our sensory perception?*, *What are the limitations of language in our philosophical conversation?*, and *Does the outer world exist independent of our sensing it?* While positions on such questions are not provable, we, as thoughtful persons, conduct our affairs in the context of metaphysical systems of belief whether or not we have taken the trouble to formalize them. Those who publicly eschew metaphysics probably mean to say that they want to waste no time discussing these questions, however, a bit of introspection might expose their unexpressed operating

systems of belief.

While science devotes little direct attention to metaphysics, implicit in its methods are the following statements.¹

1. There is a real outer world that exists independently of our knowing.
2. This world is not directly knowable.

The first statement, although not universally accepted, is a tacit assumption underlying our Western culture and need not be elaborated. The second statement is not so obvious and might, at first thought, seem counter-intuitive. One might object to it by saying that we are aware of our presence in this world through interaction with our senses. One must then go a step further and inquire as to the functioning of our senses for here is where the uncertainty appears. Research into the physiology and psychology of sensory perception has shown, for example, that we don't simply "see" an object as a camera would, but that nerve impulses are processed by the "hardware" of the brain with "software" developed from past experience. A good illustration of this is that a congenitally blind person who later receives sight finds that seeing is not automatic but must be learned. The learning process is not easy and can often be traumatic, especially if the person has been blind for a long time.² Because our sensory input is processed, we have no assurance of its fidelity and can not claim that we know the world as it actually is. Fortunately, there seems to be enough similarity in the processing equipment of individuals that we have no trouble agreeing upon our representations of the real outer world. Upon this agreement it is possible to build our structure of knowledge. It would not be profitable to dwell on the uncertainty, for if we view science as a conversation, we are assured that we are each talking about the same things.

There is another sense in which the knowledge generated by science can be said to rest on things that are not directly knowable; some of the objects of our theories can not be directly experienced. Many aspects of our world are changeable and unpredictable, but it seems to be a deep-seated psychological need for us to find order and permanence. Because these qualities are not outwardly apparent, we seek them behind the appearances. We seek explanations of change and chance in terms of mechanisms that we believe are reliable and timeless and thus attempt to construct an unchanging, underlying reality that gives rise to the world that we experience with our senses. We have been doing this since the early days of philosophy. For example, the idea that matter is composed of atoms and that its properties are determined by their motions is usually ascribed to Democritus who lived in the fifth century B.C.

The subjects to be covered in this chapter — mathematics, and the nature and methods of science — are frequent topics in the philosophical conversation and have inspired an extensive and perhaps daunting literature. Rather than delineate and compare the thought of the various schools, a pragmatically eclectic approach will be followed taking due care not to become bogged down in excessive rigor or detail. With philosophical inquiry there seems to be an optimum depth; too little is superficial but too much brings up questions with which we can make little headway. Here moderation seems an admirable goal.

¹ M. Planck, as quoted in *Science and Synthesis*, a Unesco Symposium, Springer-Verlag, Berlin, 1971, p68.

² Some interesting cases are given by Zajonc. A. Zajonc, *Catching the Light*, Bantam Books, New York, 1993.

1.2 MATHEMATICS

If asked to define mathematics, an engineer or scientist would probably offer something like the following: *Mathematics is a free-standing, self-consistent system of logic useful for dealing with problems that can be quantified.* A mathematician might not seriously object to this definition provided the word problems is not restricted to practical problems, but includes all quantifiable problems the human intellect is capable of grasping. With this broader definition, mathematics is seen to be a structured intellectual activity which impresses us with its clarity and precision. Many who have known it were enrapt with its purity and beauty and, awed by its power and scope, have even dared to ascribe to it a mystical aura. The mystical aura has always been there; it inspired the Pythagoreans to construct a world view based on geometry, number, and proportion. Later, it inspired Galileo to state that "God is a mathematician" and it is clearly discerned in the writings of Einstein.

That which we know as mathematics originated with the Greeks as geometry. A practical form of geometry was known and used by the Egyptians and the Babylonians, but the Greeks transformed it into an intellectual activity involving axioms and proofs. Yet as the prefix *geo* suggests, it was still believed to express truth about the physical world. It was not until the development of non-Euclidean geometries in the nineteenth century that this view had to be revised. Until Riemann's unification, there were three legitimate geometries, each an intellectual structure consistent with its axioms. The two new geometries differed from Euclidean geometry only in the fifth of Euclid's axioms — *given a line and a point not lying on the line, there is only one line that can be drawn through the point that is parallel to the original line.* One non-Euclidean geometry stated that no parallels can be drawn, while the other stated that at least two parallels can be drawn. Riemann unified the three geometries with the concept of curvature of space and then extended his unified geometry to more than three dimensions.

But for the fact that Einstein used Riemann's unified geometry in developing the general theory of relativity, non-Euclidean geometries might have been regarded solely as intellectual creations expressing pure mathematical truth. This truth is defined as self-evident proof based on stated axioms and accepted rules of procedure, but no claim is made as to whether the axioms themselves are true in the sense that they possess physical significance. Undoubtedly much of the large body of mathematics can be so regarded, however, some of it has proved quite useful in describing the physical world. Now, we are prompted to ask: *Does mathematical truth pre-exist and is simply discovered by the mathematician or is it non-existent until created by the mathematician?* Historically, the pre-existent view, first attributable to Plato, has been dominant, but developments such as non-Euclidean geometry seriously challenge it. Today there doesn't seem to be a clear consensus on this question.

There is a more practical problem concerning mathematical truth: what constitutes a self-evident proof; can a general algorithmic procedure be developed that could be systematically applied and used for all proofs? This project received considerable attention in the early years of this century, but had to be abandoned in the 1930's when K. Gödel published what is known as his incompleteness theorem. Essentially, Gödel proved that³ any formal mathematical system of axioms and rules of procedure, if free from contradiction, must contain some statements which are neither provable or disprovable by the means allowed within the system. This would, of course, be true of any

³ This account follows closely that of R. Penrose, *The Emperor's New Mind*, Oxford University Press, Oxford, 1989, Ch.4.

algorithmic procedure designed to systematize mathematical proof.

As it appears that mathematics can never be a complete structure and can not be thoroughly systematized, what now will constitute self-evident proof? Obviously, it will be determined by a consensus of competent mathematicians; but how does each one become convinced? An answer to this has been supplied by Roger Penrose, a prominent mathematician⁴

"Mathematical truth is *not* something that we ascertain merely by use of an algorithm. I believe, also, that our *consciousness* is a crucial ingredient of our comprehension of mathematical truth. We must 'see' the truth of a mathematical argument to be convinced of its validity. This 'seeing' is the very essence of consciousness. It must be present *whenever* we directly perceive mathematical truth."

Thus, even for a system that deals only in pure rational thought and makes no claim to truth about matters in the physical world, there can be no absolute certainty concerning truth. Instead there is a somewhat mystical trust in the reliability of our consciousness.

1.3 SCIENCE AND ITS METHOD

We have previously defined science as a search for truth about the real outer world based on a systematic application of rational thought. Because the ultimate goal of our discussion is to examine thermodynamics, a highly mathematical subject, our discussion of science will be focused on physics, the most mathematical branch of science and the most fundamental.

Galileo is considered to be the first scientist because he conducted experiments and expressed the results mathematically. Newton, born in the year Galileo died, achieved outstanding success in developing a unified mathematical representation of the solar system based on Kepler's three laws of planetary motion which were also stated mathematically. The key to Newton's success in describing the planetary orbits was the idea that an attractive gravitational force, inversely proportional to the square of the distance from the planet to the sun, balanced the centrifugal force on the planet and produced a stable orbit. Newton was not comfortable with this gravitational force that acted at a distance and he stated that he "framed no hypothesis" about its origin or mechanism. As we view science today, we would say that Newton framed an hypothesis, or rather, proposed a theory, when he equated the gravitational and centrifugal forces and proposed the inverse square dependence of the gravitational force on distance. The theory could be deemed successful because its predictions were consonant with the known facts.

The intimate connection between theory and experiment is often overlooked or misunderstood. Frequently, scientists refer to themselves as theorists or experimentalists as if these two aspects of science could be cleanly separated. It is a common belief that theories arise from obvious implications inherent in the accumulated results of experiments and that experimental investigation must precede the development of theory. This view is reinforced by the customary style of scientific writing which suggests that theory is arrived at by inductive reasoning applied to experimental data. A excellent illustration the role of theory can be found in Einstein's theory of Brownian motion which brought understanding to a phenomenon that had been the subject of many years of unfruitful experimental

⁴ R.Penrose, *ibid*, p 418.

study. A thorough discussion of this situation is given by Brush⁵ who states

"One can hardly find a better example in the history of science of the complete failure of experiment and observation, unguided by theory, to unearth the simple laws governing a phenomenon."

While philosophers and historians of science are unable to agree upon a single set of algorithms that would characterize the workings of science, there is general agreement that induction plays a minor role. Further, most would agree that what is normally taken to be an experimental fact is actually intimately dependent on theory. A great deal of the measurements performed in a typical experiment are based on previously accepted theory and few measurements are pure in the sense that they require no theory-based corrections. Moreover, the experimentalist requires some sort of theoretical context in which to place the studied phenomena and to suggest the measurements that ought to be made.

A most enlightening visual representation of the interaction of experiment and theory has been devised by Henry Margenau⁶ and is shown in Figure 1-1.

The diagram is divided into a perceptual plane, the "P-plane", where experimental facts are located and a "C-field" which contains the constructs of theories, shown as circles. Single lines show how the constructs are connected by theory and double lines show how some of the constructs are directly connected to experimental measurements lying on the P-plane. The distance of a construct from the P-plane is a measure of its abstractness, however, more abstractness is acceptable if the theory containing the construct subsumes other theories. The goal of science is to construct a pyramid in the C-field whose broad base is the P-plane and whose apex lies considerably to the left of the P-plane. For example, the special theory of relativity unites Newtonian mechanics and Maxwell's theory of electricity and magnetism; it is more abstract and would be located deeper into the C-field.

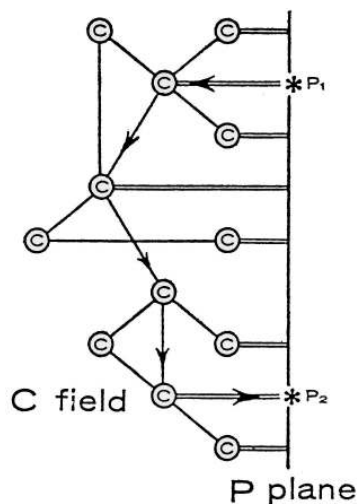

Figure 1-1. Margenau Diagram (From reference 6)

To be accepted into the conversation of science a theory must be confirmed. The nature of the confirmation process is indicated in Figure 1-1 where an observation, shown as P1 on the P-plane, is processed by theory in the C-field to produce a prediction, P2, on the P-plane. An example might be an observation of the position and velocity of a comet, P1, which is used in the system of Newtonian mechanics to predict a future position, P2, which can be verified by observation. The verification process begins and ends on the P-plane and loops through the C-field.

Before a theory can be taken seriously in the conversation of science, it must possess other attributes in addition to experimental verification. These attributes are not considered in a formal manner, but seem to be generally accepted by tacit agreement among scientists. They may even be

⁵ S.G.Brush, *The Kind of Motion We Call Heat*, North-Holland Publishing Co., Amsterdam, 1976, p682.

⁶ H.Margenau, *Open Vistas*, Ox Bow Press, Woodbridge, CT, 1983, Ch.1.

considered instinctive. Among those listed by Henry Margenau⁷ we find attributes of logical fertility, extensibility, multiple connections, simplicity, and elegance. A theory may be considered logically fertile if it improves our insight and suggests new and fruitful questions. Taken together extensibility and multiple connections refer to the ability of a theory to subsume or connect with other theories. In terms of Figure 1-1 the new theory would tighten the network of single lines connecting the concepts in the C-field and perhaps provide new double-lined links to the P-plane. The attributes of simplicity and elegance go together and can not be explicated; they are simply applied intuitively and therefore are subjective responses.

The question as to the reality of constructs in the C-field is rarely raised. Science is pragmatic and progress would be slowed by debating questions such as *Is an electron real?* The construct of an electron is involved in many theories and can be visualized as a vital part of a tightly linked network in the C-field. While such success leads us to believe that we are nearing the bedrock of truth, we can never be sure that there is not another construct that would be even more fruitful. However, through repeated application, the construct of an electron has almost become second nature to us in our thinking about the real outer world. We would be foolish to distrust or discard so valuable a construct even if in our moments of deepest thought we may have questioned its reality.

Questioning the reality of an electron is perhaps an oblique way of asking whether science discovers truth or invents it. There is no doubt that up to the beginning of this century the predominant view was that science discovered truth by learning to read the book of Nature which Galileo had said was written in the language of mathematics. Accompanying this view was the belief that in well-designed experiments the act of observing or measuring would have a negligible effect on the phenomena under study. Today, this view seems untenable in the realm of the atom where quantum mechanics, with its uncertainty principle and concept of complementarity, tells us that the act of observation can decide the outcome of the experiment. Further, the statistical nature of quantum mechanics has brought into question the traditional view of a deterministic law of science. These developments have led many scientists to a subjective view of reality as illustrated by the words of Eugene Wigner⁸, Nobel laureate in physics:

"It is not possible to formulate the laws of quantum mechanics in a fully consistent way without reference to the consciousness."

Returning to our previous metaphor, this view suggests that while straining to decipher the book of Nature we suddenly realize that this crabbed writing is in our own hand.

In our discussion of its methods, science has been portrayed as logical, systematic, and pragmatic, attributes which if applied to a person would not be considered flattering. We have missed the spirit of science — the awe, the wonder, and the mystical aura that come through in the writings of many great scientists. For example, Einstein expressed awe that "The eternally incomprehensible thing about the world is its comprehensibility." and in contemplating the effectiveness of theory wrote

"How is it possible that mathematics, a product of human thought that is independent of experience, fits so excellently the objects of physical reality? Can human reason without experience discover by pure thinking properties of real things?"

⁷ *ibid*

⁸ E. Wigner, *Symmetries and Reflections*, Indiana University Press, Bloomington, 1967.

And Wolfgang Pauli, searching for the origins of theory, has written⁹

"What is the nature of the bridge between the sense perceptions and the concepts? All logical thinkers have arrived at the conclusion that pure logic is fundamentally incapable of constructing such a link. ... The process of understanding Nature ... seems thus to be based on a correspondence, a "matching" of inner images pre-existent in the human psyche with external objects and their behavior."

The mystical faith implied in these words is wonderfully echoed in the following dialog from Bertolt Brecht's *Galileo*

BARBERINI: You think in terms of circles and ellipses, of uniform velocities and simple motions, that is, of things similar to your mind. But suppose the Almighty decided stars should move like this (makes a strange gesture). Where would your calculations go then?

GALILEO: Then, Your Eminence, God would have made our minds like this (makes the same gesture), so we could believe a motion like this is simple. I believe in the human mind.

Regardless of whether one believes that science deciphers or composes the book of Nature, it seems obvious that it runs on faith — faith in the human mind. Just as mathematicians have faith in their consensus on self-evident proof, those who practice science have faith in a consensus reached through the application of its methods.

1.4 THERMODYNAMICS

Here an overview of thermodynamics will be presented with the intent of defining and describing it in rather broad terms. Some topics that are lightly covered here will be developed in more detail in later chapters. The intent of this section is to provide the context for these later explorations. Many modern-day textbook authors take statistical mechanics to be an integral part of thermodynamics, but here the term thermodynamics will refer to classical or phenomenological thermodynamics. One of the objectives of this work is to examine thermodynamics and its relationship to statistical mechanics.

1.4.1 The Strangeness of Thermodynamics. Among those formally exposed to thermodynamics, few would disagree that while there is no doubt of its usefulness, there is also no doubt of its strangeness. Lest this be taken as a defect in our intellectual powers, it is both appropriate and comforting to quote two Nobel laureates in physics who have publicly acknowledged their discomfort with the subject. Max Born, one of the founders of quantum mechanics, freely admits his mystification¹⁰

"I tried hard to understand the classical foundations of the two theorems, as given by Clausius and Kelvin; they seemed to me wonderful, like a miracle produced by a magician's wand, but I could not find the logical and mathematical root of these

⁹ C.G. Jung and W.Pauli, *The Interpretation of Nature and the Psyche*, Pantheon Books, New York, 1955, p151.

¹⁰ Max Born, *My Life: Recollections of a Nobel Laureate*, Taylor and Francis Ltd., London, 1978, p119.

marvelous results."

And Percy Bridgman, a respected thermodynamicist, is bothered by the strange human-scented quality permeating thermodynamics¹¹

"It must be admitted, I think, that the laws of thermodynamics have a different feel from most of the other laws of the physicist. There is something more palpably verbal about them — they smell more of their human origin. The guiding motif is strange to most of physics: namely, a capitalizing of the universal failure of human beings to construct perpetual motion machines of either the first or second kind. Why should we expect Nature to be interested either positively or negatively in the purposes of human beings, particularly purposes of such an unblushingly economic tinge?"

The most notable aspect of this strangeness is the mathematics employed by thermodynamics. The reason for this is that there is an excess of variables in thermodynamics. A simple system is defined when two variables are determined, but thermodynamics does not specify which two among the many variables should be chosen. For example, if the system were a quantity of gas, the two variables describing the system could be chosen from among temperature, T , pressure, P , volume, V , internal energy, U or entropy, S . Because it is necessary to identify our choice of variables, the equations used to describe the system must be adorned with the appropriate subscripts. This gives an ungraceful appearance to the equations of thermodynamics. On the other hand, no surfeit of variables exists when applying the other laws of classical physics and these equations are more aesthetically pleasing.

Again, contrasting the mathematics of thermodynamics with that of classical physics, we note that the defined thermodynamic variables, internal energy and entropy, cannot be expressed as absolute values¹² and are always written as changes between two states. This feature derives from the central idea of thermodynamics — the concept of a state and a state variable. With the exception of heat and work, all thermodynamic variables are state variables.¹³ To improve our understanding of a system we would like to know how the system moved between initial and a final states, but thermodynamics does not provide that information. Also, thermodynamics has nothing at all to say about the time required for the system to move between the two states; time is not a thermodynamic variable. While the silence of thermodynamics on these points is an obvious disadvantage to the state approach, there are compensations — namely, flexibility and economy of description.

The state of a gas is defined when any two of the state variables T , P , V , U , or S are specified. This means that the values of all of the other state variables are fixed and that between any two such specified states the changes in these variables are fixed regardless of the actual path taken by the system. Because of this, changes in state variables can be evaluated by any convenient path. Thus, we can choose variables that are convenient and we need not be concerned with mechanistic particulars when applying thermodynamics. Unfortunately, these advantages often cause discomfort for the

¹¹ P.W.Bridgman, *The Nature of Thermodynamics*, Harper & Brothers, New York, 1961, p3.

¹² The third law and absolute entropy is discussed in Ch. 3 of my essay *ENTROPY*.

¹³ The state approach, first applied to thermodynamics by Gibbs, is also used in quantum mechanics with considerable success.

neophyte or casual observer, for it would seem that thermodynamics revels in indifference and arbitrariness.

There are two other factors that contribute to the aura of strangeness surrounding thermodynamics — the reversible process and the standard state. The reversible process is an idealization necessary for the development and implementation of thermodynamics, and it imposes conditions that can be approached in practice. While one can usually visualize the physical conditions required to approach reversibility, the concept of a standard state, so useful in dealing with chemical reactions, often involves conditions that can not be physically realized. Both of these concepts impart a certain amount of artificiality and remoteness to thermodynamics.

1.4.2 The Method of Thermodynamics. There are three major applications of thermodynamics:

1. The first and second laws can be applied to the calculation of heat and work effects associated with processes. This would include finding the maximum work obtainable from a process, the minimum work to drive the process, or whether a proposed process is possible. The answer to the last question is a permissive yes if neither law is violated, but an emphatic no for any violation.
2. The established network of thermodynamic equations can be used to determine relationships among the state variables of a system. These relationships can be used to calculate values of variables that are difficult to measure from values of variables that are easier to measure.
3. Special functions defined by thermodynamics can be used to make calculations involving phase and chemical equilibrium.

Actually, the property changes needed for the first application must be calculated from experimental data via the thermodynamic network. Therefore, in all its applications thermodynamics requires experimental information. Often it is easy to miss this intimate experimental dependence when solving textbook problems in which the steam tables are used or where the substance is conveniently specified as an ideal gas with a specified heat capacity. When the origin of the data is not recognized, thermodynamics is disassociated from its experimental context and rendered a lifeless and meaningless set of equations.

The experimental context suggests the following definition. It is intended to be heuristic rather than rigorous and should be suitable for the discussion which follows.¹⁴

Thermodynamics may be broadly defined as a means of extending our experimentally gained knowledge of a system or as a framework for viewing and correlating the behavior of the system.

Accordingly, it would be better to speak of the thermodynamic method rather than thermodynamics as an area of science; the adjective *thermodynamic* is preferable to the noun *thermodynamics*. One is certainly justified in protesting that this definition is so general that it could be applied to almost any area of science or to science in general. Nevertheless, because it will aid our understanding of thermodynamics, this non-exclusive definition will be useful.

The thermodynamic method is quite general and is capable of treating any system which can exist in an observable and reproducible equilibrium state and which can exchange heat and work with

¹⁴ B.G.Kyle, *Chemical and Process Thermodynamics*, 3rd Ed., Prentice-Hall International, Englewood Cliffs, 1999, p2.

the surroundings. In addition to fluids, chemically reacting systems, and systems in phase equilibrium, thermodynamics has also been successfully applied to stressed solids, systems with surface effects, and substances subjected to gravitational, centrifugal, magnetic, and electric fields.¹⁵

A diagram illustrating the development of the thermodynamic network and the application of the thermodynamic method is shown on Figure 1-2. The sequence of rectangles connected by heavy arrows traces the development of the laws, functions, and relationships that constitute the thermodynamic network — the tools of thermodynamics. The sequence of circles connected by light arrows shows the steps in applying thermodynamics to the solution of practical problems, and the dashed arrows indicate where the various thermodynamic tools are employed in the problem-solving process.

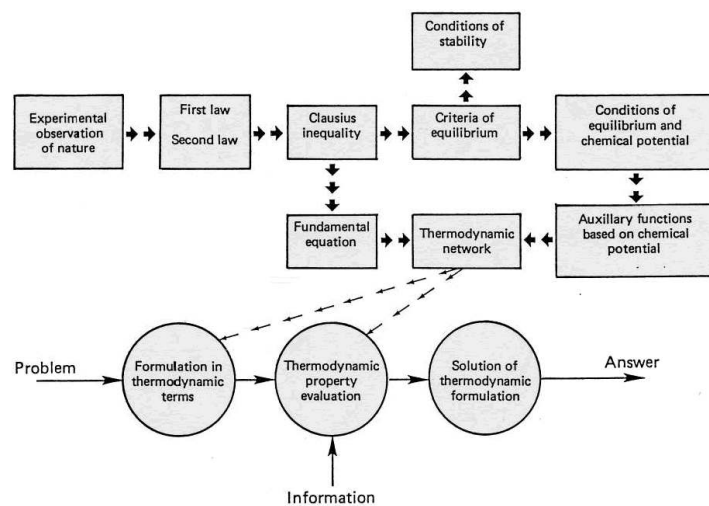

Figure 1-2. Road map for the conceptual development and application of thermodynamics

The first and second laws have been fashioned in mathematical language from statements of experience and have defined the functions U and S . These functions, previously unknown, were shown to be state functions. The combination of these two laws and the application of the methods of the calculus yields a network of relationships among the state properties. Thus, the laws which define U and S lead eventually to the prescriptions for their evaluation from experimental data.

A new and useful state variable, the chemical potential, can be identified when the laws are extended to include mixtures. This application of the laws leads to the specification of the conditions of equilibrium which require that the temperature, pressure, and chemical potential be uniform throughout the system. The chemical potential and other functions derived from it form the basis of the thermodynamic treatment of phase and chemical equilibrium and the equations relating these functions are also a part of the thermodynamic network.

As we have seen, the entire thermodynamic network derives from the first and second laws. The laws are unquestioned, but their acceptance rests mainly on the successful application of the network they support; the experimental evidence for the laws *per se* is not overwhelming. The application of thermodynamics is represented in Figure 1-2 as a three-step process requiring the input of experimental information. This figure can be visualized in terms of a Margenau diagram if the thermodynamic network and the three-step solution process are located in the C-field and the arrows showing input and output of the solution train are considered to cross the P-plane. While the problem-solving process shown in Figure 1-2 is certainly not unique to thermodynamics, there are certain features that distinguish thermodynamic problems. The most obvious feature is that the defined thermodynamic variables (e.g., U and S , and chemical potential) do not appear in either the problem statement or the solution. These variables are simply used to solve the problem and therefore have no

¹⁵ For a generalization of the thermodynamic method see B.G.Kyle, *ibid*, Ch 5

ultimate value beyond this application; in a sense they are dummy variables. Contrast this situation with that of fluid mechanics, for example, where the variables velocity, time, and position are part of the problem statement, are the variables in which the theory is formulated, and are the variables in which the solution is expressed. In addition to not being intrinsic to the problem statement or solution, the defined thermodynamic variables often require complicated, multi-step paths for their evaluation. Sometimes the path includes hypothetical steps and requires several types of experimental data. The thermodynamic method is thus characterized by an emphasis on information processing.

In both structure and application, thermodynamics resembles mathematics; both are self-contained and confidently used and both contain much that is never used. Just as much of mathematics has found no application, there are many unused relationships in the thermodynamic network. And when unacceptable results are obtained from the application of either of these tools, and no errors are found in the execution, it is the conceptual description of the system that must accommodate.

To understand this state of affairs it is necessary to distinguish the thermodynamic network, which derives solely from the first and second laws, from the equation of state used to describe the particular system. The equation of state is an algebraic equation that relates the state variables of the system: the ideal gas law or Currie's law for paramagnetic systems. Often the equation of state will have a theoretical basis (e.g., the ideal gas law or the virial equation of state), but its justification or the determination of its parameters is always empirical. When the relationships of the network are used with an equation of state, results specific to that system are obtained. Thus, if the thermodynamic method were applied to a gas with unsatisfactory results, the efficacy of the equation of state would be questioned and a more descriptive, and usually a more complex, equation of state would be employed.

Also, in applying the thermodynamic method it is necessary to know that the system is properly defined in terms of the state variables. The phase rule provides this guidance for conventional applications, but there are some systems that require the specification of additional state variables such as field strength or surface area. When these systems are encountered it is necessary to revise the fundamental equation to account for the various ways in which the system can exchange work with the surroundings. The details of the thermodynamic network will change as a result of this new formulation, but the basic method for working out the details of the network remains unchanged.

1.4.3 The Nature of Thermodynamics. The three major areas of classical physics are mechanics, electromagnetic theory, and thermodynamics and it seems to be a source of embarrassment to many physicists that thermodynamics does not fit too well into this triumvirate. The reasons for this lack of fit have already been discussed.

Statistical mechanics began as an effort to bring thermodynamics into closer conformity with the rest of classical physics. Here the methods of mechanics were applied statistically to the astronomically large number of molecules constituting the average thermodynamic system. Quantum mechanics developed somewhat later and was shown to subsume statistical mechanics. This new field, now known as quantum statistical mechanics (QSM), has proven to be a valuable adjunct to thermodynamics by allowing the evaluation of thermodynamic properties from molecular parameters. However, despite this practical success, there is still some uncertainty in explaining entropy in molecular terms. The formulations resulting from QSM relate entropy to the number of accessible quantum states or the probabilities of the various quantum states. If the entropy were an intrinsic property of matter, and not just a defined state function, one would expect a microscopic formulation to be expressed in terms of *physical* quantities. Instead it is related to the *logical* quantities which do

not refer to any physical aspect of the system, but to the manner in which we choose to represent the system. Early workers in statistical mechanics referred to these expressions as entropy analogues. Now, they are called statistical entropy, or often, they are simply called entropy. They provide the basis for the putative interpretation of entropy as a measure of disorder.

The situation in regard to entropy became more confusing when an equation arising from communication theory and resembling the QSM formulation was also given the name of entropy. Because it defines the information content of a message, it is usually referred to as information entropy, however, the unmodified term entropy is often used. More recently, the confusion has increased with the assertion that there is an entropy change associated with memory erasure in computers — a computing entropy. In chapters 4 & 5 of my essay *ENTROPY* an attempt will be made to clarify this situation.

The impressive success of quantum statistical mechanics has prompted many scientists to state that the second law is statistical in nature. Some even go so far as to suggest that statistical mechanics subsumes thermodynamics. This undoubtedly holds great appeal to those who are uncomfortable with the lack of fit in the triumvirate of classical physics. These questions will be explored in *Entropy: a Philosophical View*