

PRENTICE HALL  
**SCIENCE  
EXPLORER**



**Grade 7**

**LABORATORY  
MANUAL**

*Includes  
Guided-Inquiry  
and  
Open-Ended  
Labs*

- ◆ 20 unique in-depth investigations
- ◆ All labs tested and safety reviewed
- ◆ Pre-Lab Discussions and Critical-Thinking Questions
- ◆ Safety Manual and Student Safety Test

PRENTICE HALL

**SCIENCE  
EXPLORER**



**Grade 7**

**Laboratory  
Manual**

**Student Edition**



Needham, Massachusetts  
Upper Saddle River, New Jersey  
Glenview, Illinois

## Safety Reviewers

### **W. H. Breazeale, Ph.D.**

Department of Chemistry  
College of Charleston  
Charleston, South Carolina

### **Ruth Hathaway, Ph.D.**

Hathaway Consulting  
Cape Girardeau, Missouri

## Field Testers

### **Tom Barner**

F. A. Day Middle School  
Newton, Massachusetts

### **Nikki Bibbo**

Russell Street School  
Littleton, Massachusetts

### **Rose-Marie Botting**

Broward County School District  
Fort Lauderdale, Florida

### **Tom Messer**

Cape Cod Academy  
Osterville, Massachusetts

### **Carol Pirtle**

Hale Middle School  
Stow, Massachusetts

### **Pasquale Puleo**

F. A. Day Middle School  
Newton, Massachusetts

### **Anne Scammell**

Geneva Middle School  
Geneva, New York

Copyright © by Prentice-Hall, Inc., Upper Saddle River, New Jersey 07458. All rights reserved.  
Printed in the United States of America. This publication is protected by copyright, and permission should be obtained from the publisher prior to any prohibited reproduction, storage in a retrieval system, or transmission in any form or by any means, electronic, mechanical, photocopying, recording, or likewise. Student worksheets and tests may be duplicated for classroom use, the number not to exceed the number of students in each class. Notice of copyright must appear on all copies. For information regarding permission(s), write to: Rights and Permissions Department.



SI Units and Conversion Tables .....iv

**Student Safety Manual**

Science Safety Rules ..... v  
 Safety Symbols ..... vii  
 Laboratory Safety Contract .....viii  
 Student Safety Test .....ix  
 Laboratory Skills Checkup 1 .....xiii  
 Laboratory Skills Checkup 2 .....xiv  
 Laboratory Skills Checkup 3 .....xv  
 Laboratory Skills Checkup 4 .....xvi

**Laboratory Investigations**

Introduction Lab How to Use a Balance ..... 1  
 1 Finding Average Mass .....5  
 2 Testing for Hard Water .....9  
 3 Determining Solubility .....13  
 4 Weight and the Force of Gravity .....19  
 5 Pulleys as Simple Machines .....23  
 6 Winding Up With Wind .....27  
 7 Investigating Soils and Drainage .....31  
 8 The Daily Grind .....35  
 9 Constructing a Foucault Pendulum .....39  
 10 Examining Bones, Muscles, and Skin .....43  
 11 Nutrient Identification .....47  
 12 Direction of Blood Flow .....53  
 13 Measuring the Volume of Exhaled Air .....57  
 14 Do Mouthwashes Work? .....61  
 15 Locating Touch Receptors .....65  
 16 Model of a Negative Feedback Mechanism .....69  
 17 Ecosystem Food Chains .....75  
 18 Family Life of Bettas .....79  
 19 Managing Fisheries .....85

# SI UNITS AND CONVERSION TABLES

## Common SI Units

Measurement	Unit	Symbol	Equivalents
Length	1 millimeter	mm	1,000 micrometers ( $\mu\text{m}$ )
	1 centimeter	cm	10 millimeters (mm)
	1 meter	m	100 centimeters (cm)
	1 kilometer	km	1,000 meters (m)
Area	1 square meter	$\text{m}^2$	10,000 square centimeters ( $\text{cm}^2$ )
	1 square kilometer	$\text{km}^2$	1,000,000 square meters ( $\text{m}^2$ )
Volume	1 milliliter	mL	1 cubic centimeter ( $\text{cm}^3$ or cc)
	1 liter	L	1,000 milliliters (mL)
Mass	1 gram	g	1,000 milligrams (mg)
	1 kilogram	kg	1,000 grams (g)
	1 ton	t	1,000 kilograms (kg) = 1 metric ton
Time	1 second	s	
Temperature	1 Kelvin	K	1 degree Celsius ( $^{\circ}\text{C}$ )

## Metric Conversion Tables

When You Know	Multiply by	To Find		
		When You Know	Multiply by	To Find
inches	2.54	centimeters	0.394	inches
feet	0.3048	meters	3.281	feet
yards	0.914	meters	1.0936	yards
miles	1.609	kilometers	0.62	miles
square inches	6.45	square centimeters	0.155	square inches
square feet	0.093	square meters	10.76	square feet
square yards	0.836	square meters	1.196	square yards
acres	0.405	hectares	2.471	acres
square miles	2.59	square kilometers	0.386	square miles
cubic inches	16.387	cubic centimeters	0.061	cubic inches
cubic feet	0.028	cubic meters	35.315	cubic feet
cubic yards	0.765	cubic meters	1.31	cubic yards
fluid ounces	29.57	milliliters	0.0338	fluid ounces
quarts	0.946	liters	1.057	quarts
gallons	3.785	liters	0.264	gallons
ounces	28.35	grams	0.0353	ounces
pounds	0.4536	kilograms	2.2046	pounds
tons	0.907	metric tons	1.102	tons

When You Know		
Fahrenheit	subtract 32; then <i>divide</i> by 1.8	to find Celsius
Celsius	multiply by 1.8; then <i>add</i> 32	to find Fahrenheit

© Prentice-Hall, Inc.

To prepare yourself to work safely in the laboratory, read over the following safety rules. Then read them a second time. Make sure you understand and follow each rule. Ask your teacher to explain any rules you do not understand.

### Dress Code

1. To protect yourself from injuring your eyes, wear safety goggles whenever you work with chemicals, flames, glassware, or any substance that might get into your eyes. If you wear contact lenses, notify your teacher.
2. Wear an apron or coat whenever you work with corrosive chemicals or substances that can stain.
3. Tie back long hair to keep it away from any chemicals, flames, or equipment.
4. Remove or tie back any article of clothing or jewelry that can hang down and touch chemicals, flames, or equipment. Roll up or secure long sleeves.
5. Never wear open shoes or sandals.

### General Precautions

6. Read all directions for an experiment several times before beginning the activity. Carefully follow all written and oral instructions. If you are in doubt about any part of the experiment, ask your teacher for assistance.
7. Never perform activities that are not assigned or authorized by your teacher. Obtain permission before “experimenting” on your own. Never handle any equipment unless you have specific permission.
8. Never perform lab activities without direct supervision.
9. Never eat or drink in the laboratory.
10. Keep work areas clean and tidy at all times. Bring only notebooks and lab manuals or written lab procedures to the work area. All other items, such as purses and backpacks, should be left in a designated area.
11. Do not engage in horseplay.

### First Aid

12. Always report all accidents or injuries to your teacher, no matter how minor. Notify your teacher immediately about any fires.
13. Learn what to do in case of specific accidents, such as getting acid in your eyes or

on your skin. (Rinse acids from your body with plenty of water.)

14. Be aware of the location of the first-aid kit, but do not use it unless instructed by your teacher. In case of injury, your teacher should administer first aid. Your teacher may also send you to the school nurse or call a physician.
15. Know the location of the emergency equipment such as fire extinguisher and fire blanket.
16. Know the location of the nearest telephone and whom to contact in an emergency.

### Heating and Fire Safety

17. Never use a heat source, such as a candle, burner, or hot plate, without wearing safety goggles.
18. Never heat anything unless instructed to do so. A chemical that is harmless when cool may be dangerous when heated.
19. Keep all combustible materials away from flames. Never use a flame or spark near a combustible chemical.
20. Never reach across a flame.
21. Before using a laboratory burner, make sure you know proper procedures for lighting and adjusting the burner, as demonstrated by your teacher. Do not touch the burner. It may be hot. Never leave a lighted burner unattended. Turn off the burner when not in use.
22. Chemicals can splash or boil out of a heated test tube. When heating a substance in a test tube, make sure that the mouth of the tube is not pointed at you or anyone else.
23. Never heat a liquid in a closed container. The expanding gases produced may shatter the container.
24. Before picking up a container that has been heated, first hold the back of your hand near it. If you can feel heat on the back of your hand, the container is too hot to handle. Use an oven mitt to pick up a container that has been heated.

### Using Chemicals Safely

25. Never mix chemicals “for the fun of it.” You might produce a dangerous, possibly explosive substance.

## SCIENCE SAFETY RULES *(continued)*

26. Never put your face near the mouth of a container that holds chemicals. Many chemicals are poisonous. Never touch, taste, or smell a chemical unless you are instructed by your teacher to do so.
27. Use only those chemicals needed in the activity. Read and double-check labels on supply bottles before removing any chemicals. Take only as much as you need. Keep all containers closed when chemicals are not being used.
28. Dispose of all chemicals as instructed by your teacher. To avoid contamination, never return chemicals to their original containers. Never pour untreated chemicals or other substances into the sink or trash containers.
29. Be extra careful when working with acids or bases. Pour all chemicals over the sink or a container, not over your work surface.
30. If you are instructed to test for odors, use a wafting motion to direct the odors to your nose. Do not inhale the fumes directly from the container.
31. When mixing an acid and water, always pour the water into the container first then add the acid to the water. Never pour water into an acid.
32. Take extreme care not to spill any material in the laboratory. Wash chemical spills and splashes immediately with plenty of water. Immediately begin rinsing with water any acids that get on your skin or clothing, and notify your teacher of any acid spill at the same time.

### Using Glassware Safely

33. Never force glass tubing or a thermometer into a rubber stopper or rubber tubing. Have your teacher insert the glass tubing or thermometer if required for an activity.
34. If you are using a laboratory burner, use a wire screen to protect glassware from any flame. Never heat glassware that is not thoroughly dry on the outside.
35. Keep in mind that hot glassware looks cool. Never pick up glassware without first checking to see if it is hot. Use an oven mitt. See rule 24.
36. Never use broken or chipped glassware. If glassware breaks, notify your teacher and dispose of the glassware in the proper broken-glassware container.

37. Never eat or drink from glassware.
38. Thoroughly clean glassware before putting it away.

### Using Sharp Instruments

39. Handle scalpels or other sharp instruments with extreme care. Never cut material toward you; cut away from you.
40. Immediately notify your teacher if you cut your skin when working in the laboratory.

### Animal and Plant Safety

41. Never perform experiments that cause pain, discomfort, or harm to animals. This rule applies at home as well as in the classroom.
42. Animals should be handled only if absolutely necessary. Your teacher will instruct you as to how to handle each animal species brought into the classroom.
43. If you know that you are allergic to certain plants, molds, or animals, tell your teacher before doing an activity in which these are used.
44. During field work, protect your skin by wearing long pants, long sleeves, socks, and closed shoes. Know how to recognize the poisonous plants and fungi in your area, as well as plants with thorns, and avoid contact with them. Never eat any part of a plant or fungus.
45. Wash your hands thoroughly after handling animals or a cage containing animals. Wash your hands when you are finished with any activity involving animal parts, plants, or soil.

### End-of-Experiment Rules

46. After an experiment has been completed, turn off all burners or hot plates. If you used a gas burner, check that the gas-line valve to the burner is off. Unplug hot plates.
47. Turn off and unplug any other electrical equipment that you used.
48. Clean up your work area and return all equipment to its proper place.
49. Dispose of waste materials as instructed by your teacher.
50. Wash your hands after every experiment.

*These symbols alert you to possible dangers in the laboratory and remind you to work carefully.*

 **Safety Goggles** Always wear safety goggles to protect your eyes in any activity involving chemicals, flames or heating, or the possibility of broken glassware.

 **Lab Apron** Wear a laboratory apron to protect your skin and clothing from damage.

 **Breakage** You are working with materials that may be breakable, such as glass containers, glass tubing, thermometers, or funnels. Handle breakable materials with care. Do not touch broken glassware.

 **Heat-Resistant Gloves** Use an oven mitt or other hand protection when handling hot materials. Hot plates, hot glassware, or hot water can cause burns. Do not touch hot objects with your bare hands.

 **Heating** Use a clamp or tongs to pick up hot glassware. Do not touch hot objects with your bare hands.

 **Sharp Object** Pointed-tip scissors, scalpels, knives, needles, pins, or tacks are sharp. They can cut or puncture your skin. Always direct a sharp edge or point away from yourself and others. Use sharp instruments only as instructed.

 **Electric Shock** Avoid the possibility of electric shock. Never use electrical equipment around water, or when the equipment is wet or your hands are wet. Be sure cords are untangled and cannot trip anyone. Disconnect the equipment when it is not in use.

 **Corrosive Chemical** You are working with an acid or another corrosive chemical. Avoid getting it on your skin or clothing, or in your eyes. Do not inhale the vapors. Wash your hands when you are finished with the activity.

 **Poison** Do not let any poisonous chemical come in contact with your skin, and do not inhale its vapors. Wash your hands when you are finished with the activity.

 **Physical Safety** When an experiment involves physical activity, take precautions to avoid injuring yourself or others. Follow

instructions from the teacher. Alert the teacher if there is any reason you should not participate in the activity.

 **Animal Safety** Treat live animals with care to avoid harming the animals or yourself. Working with animal parts or preserved animals also requires caution. Wash your hands when you are finished with the activity.

 **Plant Safety** Handle plants in the laboratory or during field work only as directed by the teacher. If you are allergic to certain plants, tell the teacher before doing an activity in which those plants are used. Avoid touching harmful plants such as poison ivy, poison oak, or poison sumac, or plants with thorns. Wash your hands when you are finished with the activity.

 **Flames** You may be working with flames from a lab burner, candle, or matches. Tie back loose hair and clothing. Follow instructions from the teacher about lighting and extinguishing flames.

 **No Flames** Flammable materials may be present. Make sure there are no flames, sparks, or other exposed heat sources present.

 **Fumes** When poisonous or unpleasant vapors may be involved, work in a ventilated area. Avoid inhaling vapors directly. Only test an odor when directed to do so by the teacher, and use a wafting motion to direct the vapor toward your nose.

 **Disposal** Chemicals and other laboratory materials used in the activity must be disposed of safely. Follow the instructions from the teacher.

 **Hand Washing** Wash your hands thoroughly when finished with the activity. Use antibacterial soap and warm water. Lather both sides of your hands and between your fingers. Rinse well.

 **General Safety Awareness** You may see this symbol when none of the symbols described earlier appears. In this case, follow the specific instructions provided. You may also see this symbol when you are asked to develop your own procedure in a lab. Have the teacher approve your plan before you go further.



## LABORATORY SAFETY CONTRACT

I, \_\_\_\_\_, have read  
(please print full name)

the Science Safety Rules and Safety Symbols sections on pages v–vii of this manual, understand their contents completely, and agree to demonstrate compliance with all safety rules and guidelines that have been established in each of the following categories:

(please check)

- Dress Code
- General Precautions
- First Aid
- Heating and Fire Safety
- Using Chemicals Safely
- Using Glassware Safely
- Using Sharp Instruments
- Animal and Plant Safety
- End-of-Experiment Rules

\_\_\_\_\_  
(signature)

Date \_\_\_\_\_

**STUDENT SAFETY TEST**

# Recognizing Laboratory Safety

Time Required:  
40 minutes

## ◆ Pre-Lab Discussion

An important part of your study of science will be working in a laboratory. In the laboratory, you and your classmates will learn about the natural world by conducting experiments. Working directly with household objects, laboratory equipment, and even living things will help you to better understand the concepts you read about in your textbook or in class.

Most of the laboratory work you will do is quite safe. However, some laboratory equipment, chemicals, and specimens can be dangerous if handled improperly. Laboratory accidents do not just happen. They are caused by carelessness, improper handling of equipment, or inappropriate behavior.

In this investigation, you will learn how to prevent accidents and thus work safely in a laboratory. You will review some safety guidelines and become acquainted with the location and proper use of safety equipment in your classroom laboratory.

## ◆ Problem

What are the proper practices for working safely in a science laboratory?

## ◆ Materials *(per group)*

science textbook  
laboratory safety equipment (for demonstration)

Be sure to show the location of all safety equipment in your laboratory. Also give instructions on its proper use. Guidelines pertaining to the use of special equipment, fire-drill procedures, or penalties for misbehavior in the lab might also be discussed at this time.

## ◆ Procedure

### Part A. Reviewing Laboratory Safety Rules and Symbols

1. Carefully read the list of laboratory safety rules listed on pages v and vi of this lab manual.
2. Special symbols are used throughout this lab book to call attention to investigations that require extra caution. Use page vii as a reference to describe what each symbol means in numbers 1 through 8 of Observations.

### Part B. Location of Safety Equipment in Your Science Laboratory

1. The teacher will point out the location of the safety equipment in your classroom laboratory. Pay special attention to instructions for using such equipment as fire extinguishers, eyewash fountains, fire blankets, safety showers, and items in first-aid kits. Use the space provided in Part B under Observations to list the location of all safety equipment in your laboratory.

## RECOGNIZING LABORATORY SAFETY *(continued)*

### ◆ Observations

#### Part A



1. Student is working with materials that can easily be broken, such as glass containers or thermometers. They should be handled carefully, and broken glassware should not be touched.



2. Student is working with a flame and should tie back loose hair and clothing.



3. Student should use oven mitts or other hand protection to avoid burning hands.



4. Student is working with poisonous chemicals and should not let the chemical touch the skin or inhale its vapors. Student should wash hands after the lab.



5. Student is performing an experiment in which the eyes and face should be protected by safety goggles.



6. Student is working with a sharp instrument and should direct the sharp edge or point away from himself or herself and others.



7. Student is using electricity in the laboratory and should avoid the possibility of electric shock. Electrical equipment should not be used around water, cords should not be tangled, and equipment should be disconnected when not in use.



8. Student is working with plants and should handle them according to the teacher's instructions. Student should tell the teacher if he or she is allergic to certain plants. Students should wash hands after the lab.

## RECOGNIZING LABORATORY SAFETY *(continued)*

### Part B

Student responses will depend on the specific safety features of your classroom laboratory.

Locations might include such directions as above the sink, to the right of the goggles case, near the door, and so on.

### ◆ Analyze and Conclude

Look at each of the following drawings and explain why the laboratory activities pictured are unsafe.



1. Safety goggles should always be worn whenever a person is working with chemicals, lab burners, or any substance that might get into the eyes.



2. When diluting an acid, pour the acid into water. Never pour water into the acid. Also, safety goggles and a lab apron should be worn when working with chemicals.

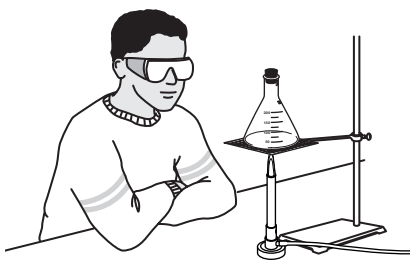

3. Never heat a liquid in a closed container. The expanding gases produced may shatter the container.

## RECOGNIZING LABORATORY SAFETY *(continued)*

### ◆ Critical Thinking and Applications

In each of the following situations, write *yes* if the proper safety procedures are being followed and *no* if they are not. Then give a reason for your answer.

1. Gina is thirsty. She rinses a beaker with water, refills it with water, and takes a drink.

**No; you should never drink from laboratory glassware. The last substance in it may have been poisonous and traces of the poison may remain.**

2. Bram notices that the electrical cord on his microscope is frayed near the plug. He takes the microscope to his teacher and asks for permission to use another one.

**Yes; electrical appliances with frayed cords or broken insulation may present a hazard and should not be used.**

3. The printed directions in the lab book tell a student to pour a small amount of hydrochloric acid into a beaker. Jamal puts on safety goggles before pouring the acid into the beaker.

**Yes; safety goggles should always be worn when working with dangerous chemicals.**

4. It is rather warm in the laboratory during a late spring day. Anna slips off her shoes and walks barefoot to the sink to clean her glassware.

**No; shoes should always be kept on while working in the laboratory in case glassware breaks or chemicals are spilled onto the floor.**

5. While washing glassware, Mike splashes some water on Evon. To get even, Evon splashes him back.

**No; misbehaving is never acceptable in a laboratory.**

6. During an experiment, Lindsey decides to mix two chemicals that the lab procedure does not say to mix, because she is curious about what will happen.

**No; never mix chemicals unless directed to do so. The mixing might produce an explosive substance.**

**LABORATORY SKILLS CHECKUP 1**

## Defining Elements of a Scientific Method

Laboratory activities and experiments involve the use of the scientific method. Listed in the left column are the names of parts of this method. The right column contains definitions. Next to each word in the left column, write the letter of the definition that best matches that word.

- |                                       |  |
|---------------------------------------|--|
| <u>  A  </u> 1. Hypothesis            | A. Prediction about the outcome of an experiment                                 |
| <u>  E  </u> 2. Manipulated Variable  | B. What you measure or observe to obtain your results                            |
| <u>  B  </u> 3. Responding Variable   | C. Measurements and other observations   |
| <u>  G  </u> 4. Controlling Variables | D. Statement that sums up what you learn from an experiment                      |
| <u>  F  </u> 5. Observation           | E. Factor that is changed in an experiment                                       |
| <u>  C  </u> 6. Data                  | F. What the person performing the activity sees, hears, feels, smells, or tastes |
| <u>  D  </u> 7. Conclusion            | G. Keeping all variables the same except the manipulated variable                |

## LABORATORY SKILLS CHECKUP 2

## Analyzing Elements of a Scientific Method

Read the following statements and then answer the questions.

1. You and your friend are walking along a beach in Maine on January 15, at 8:00 AM.
2. You notice a thermometer on a nearby building that reads  $-1^{\circ}\text{C}$ .
3. You also notice that there is snow on the roof of the building and icicles hanging from the roof.
4. You further notice a pool of sea water in the sand near the ocean.
5. Your friend looks at the icicles and the pool and says, "How come the water on the roof is frozen and the sea water is not?"
6. You answer, "I think that the salt in the sea water keeps it from freezing at  $-1^{\circ}\text{C}$ ."
7. You go on to say, "And I think under the same conditions, the same thing will happen tomorrow."
8. Your friend asks, "How can you be sure?" You answer, "I'm going to get some fresh water and some salt water and expose them to a temperature of  $-1^{\circ}\text{C}$  and see what happens."

### ◆ Questions

- A. In which statement is a **prediction** made? 7
- B. Which statement states a **problem**? 5
- C. In which statement is an **experiment** described? 8
- D. Which statement contains a **hypothesis**? 6
- E. Which statements contain **data**? 1, 2, 3, 4
- F. Which statements describe **observations**? 2, 3, 4

## LABORATORY SKILLS CHECKUP 3

## Performing an Experiment

Read the following statements and then answer the questions.

1. A scientist wants to find out why sea water freezes at a lower temperature than fresh water.
2. The scientist goes to the library and reads a number of articles about the physical properties of solutions.
3. The scientist also reads about the composition of sea water.
4. The scientist travels to a nearby beach and observes the conditions there. The scientist notes the taste of the sea water and other factors such as waves, wind, air pressure, temperature, and humidity.
5. After considering all this information, the scientist sits at a desk and writes, “If sea water has salt in it, it will freeze at a lower temperature than fresh water.”
6. The scientist goes back to the laboratory and does the following:
  - a. Fills each of two beakers with 1 liter of fresh water.
  - b. Dissolves 35 grams of table salt in one of the beakers.
  - c. Places both beakers in a freezer at a temperature of  $-1^{\circ}\text{C}$ .
  - d. Leaves the beakers in the freezer for 24 hours.
7. After 24 hours, the scientist examines both beakers and finds the fresh water to be frozen. The salt water is still liquid.
8. The scientist writes in a notebook, “It appears that salt water freezes at a lower temperature than fresh water does.”
9. The scientist continues, “I suggest that the reason sea water freezes at a lower temperature is that sea water contains dissolved salts, while fresh water does not.”

### ◆ Questions

- A. Which statement(s) contain **conclusions**? 8, 9
- B. Which statement(s) contains a **hypothesis**? 5
- C. Which statement(s) contain **observations**? 4, 7
- D. Which statement(s) describe an **experiment**? 6 a–d
- E. In which statement is the **problem** described? 1
- F. Which statement(s) contain **data**? 4, 6 a–d, 7
- G. Which is the **manipulated variable** in the experiment? the amount of salt in water
- H. What is the **responding variable** in the experiment? the temperature at which water freezes



**LABORATORY SKILLS CHECKUP 4****Identifying Errors**

Read the following paragraph and then answer the questions.

Andrew arrived at school and went directly to his earth science class. He took off his cap and coat and sat down at his desk. His teacher gave him a large rock and asked him to find its density. Realizing that the rock was too large to work with, Andrew got a hammer from the supply cabinet and hit the rock several times until he broke off a chip small enough to work with. He partly filled a graduated cylinder with water and suspended the rock in the water. The water level rose 2 cm. Andrew committed this measurement to memory. He next weighed the rock on a balance. The rock weighed 4 oz. Andrew then calculated the density of the rock as follows: He divided 2 cm by 4 oz. He then reported to his teacher that the density of the rock was .5 cm/oz.

**◆ Questions**

1. What safety rule(s) did Andrew break?

**He didn't put on his safety goggles. Also, he didn't obtain permission from his teacher before obtaining the hammer and breaking the rock.**

2. What mistake did Andrew make using measurement units?

**He used linear units (centimeters) instead of volumetric units (milliliters).**

3. What should Andrew have done with his data rather than commit them to memory?

**He should have kept a written record.**

4. What is wrong with the statement "He next weighed the rock on a balance"?

**A balance is used to determine mass, not weight.**

5. Why is "4 oz." an inappropriate measurement in a science experiment?

**Metric units (grams) should be used.**

6. What mistake did Andrew make in calculating density?

**Density is expressed in mass per unit volume (g/mL), not length per unit weight.**

**INTRODUCTION****LABORATORY INVESTIGATION**

## How to Use a Balance

### ◆ Pre-Lab Discussion

The ability to measure accurately the mass of an object is an important skill in the science laboratory. You can use a triple-beam balance to measure mass. As you can see in Figure 1, the balance has several parts. The pan is the flat surface on which you place the object to be measured. The three beams show the mass of the object. Notice that each beam has a different scale. The scale of the middle beam is from 0–500 grams and measures an object to the nearest 100 grams. The scale of the beam in back is from 0–100 grams and measures an object to the nearest 10 grams. The scale of the beam in front is from 0–10 grams and measures an object to the nearest tenth of a gram.

Notice that each beam carries a weight called a rider. You find the mass of an object by placing it on the pan and moving the riders until the pointer on the right of the balance stays pointed to zero.

There are three ways you can use the triple-beam balance to find mass:

**Method 1. Measure mass directly.**

Place the object on the pan and move the riders until the pointer points to zero. Add up the numbers on the beams where the riders are positioned to find mass.

**Method 2. Find mass by difference.** How could you find the mass of a liquid? First, measure the mass of an empty container that can hold the liquid. Then, measure the combined mass of the container and the liquid. Finally, subtract the mass of the container from the combined mass.

**Method 3. Measure out a chemical substance.** Suppose you need to obtain 50 g of a powdered chemical. How could you do it? First find the mass of a piece of paper or empty container that will hold the chemical. Then, add this amount to the desired mass of the chemical and preset the riders to this number. Finally, add the chemical to the paper a little at a time until the pointer points to zero.

In this investigation, you will learn how to measure accurately the mass of various objects by using the three methods described above.

1. What does it mean when the pointer of the balance reads “zero”?

**When the balance pointer reads “zero,” it means that the mass of the object being measured and the mass shown by the riders are equal.**

**Key Concept:** Using a triple-beam balance allows students to measure mass accurately.

**Skills Focus:** Observing, measuring, calculating, forming operational definitions

**Time Required:** 40 minutes

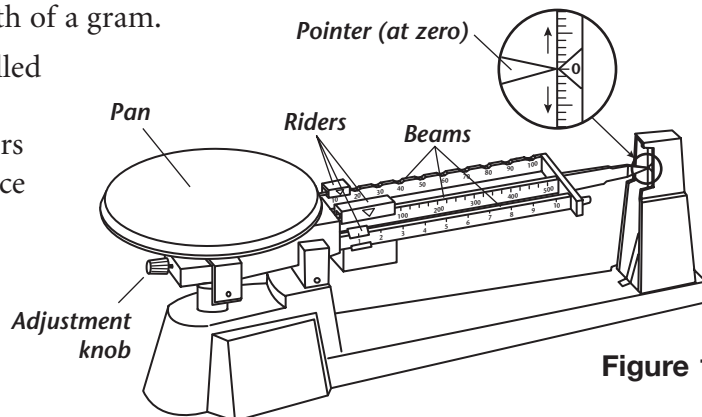

**Figure 1**

## HOW TO USE A BALANCE *(continued)*

2. Suppose a rock is balanced on a triple-beam balance. The riders on the three beams point to 60 g, 300 g, and 3.5 g. What is the mass of the rock?

363.5 g

**Advance Preparation:** Have triple-beam balances set up at student stations.

### ◆ Problem

**Alternate Materials:** Any small object can be measured, such as a coin, a paper clip, or a rubber stopper.

What is the proper way to use the triple-beam balance to measure the mass of different objects?

### ◆ Materials *(per class)*

triple-beam balance	small scoop
100-mL graduated cylinder	table salt
3 different small, solid objects	200-mL beaker
weighing paper	

**Teaching Tips:** Inform students that chemicals should never be placed directly on a balance pan. Therefore, it is necessary to use paper or a container as described in Method 3.

[Part A, Step 1] Have students measure some objects with a standard weight as a check of their measuring accuracy.

### ◆ Safety

Review the safety guidelines in the front of your lab book.

[Part C, Step 1] Filter paper may be used as weighing paper. It can be folded in quarters and then opened to form a “cup” before placing it on the pan.

### ◆ Procedure

[Part C, Step 4] Caution students not to put solids into the sink.

Before you measure the mass of any object, be sure that the riders are moved all the way to the left and that the pointer rests on zero. If necessary, slowly turn the adjustment knob until the pointer rests on zero. This is called zeroing the balance.

#### Part A: Measuring Mass Directly

- Place a small, solid object on the balance pan. The beams will rise and the pointer will point above zero.
- Move the rider on the middle beam one notch at a time until the pointer drops and stays below zero. Move the rider back one notch.
- Move the rider on the back beam one notch at a time until the pointer again drops and stays below zero. Move the rider back one notch.
- Slide the rider along the front beam until the pointer stops at zero. The mass of the object is equal to the sum of the readings on the three beams.
- Record the mass to the nearest tenth of a gram in Data Table 1.
- Remove this object and repeat steps 1–5 twice, using two other solid objects.

#### Part B: Finding Mass by Difference

- Find the mass of an empty 250-mL beaker. Record the mass in Data Table 2.
- Using the graduated cylinder, obtain 50 mL of water.
- Pour the water into the beaker and find the mass of the beaker and water. Record the mass in Data Table 2.

## HOW TO USE A BALANCE *(continued)*

### Part C: Measuring Out a Chemical Substance

1. Place a piece of weighing paper on the balance pan and find its mass. Record the mass in Data Table 3.
2. Add 5 g to the mass of the weighing paper and move the riders to this number.
3. Obtain a sample of table salt from the teacher. Using the scoop, add a small amount of salt at a time to the paper on the balance until the pointer rests on zero. Record the total mass of the weighing paper and salt in Data Table 3.
4. Dispose of the table salt in the container provided by the teacher.

### ◆ Observations

Data Table 1

Sample Data

Object	Mass (g)
Nickel	5.0
Large paper clip	1.3
Rubber stopper	12.5

Data Table 2

Mass of Empty Beaker (g)	Mass of Beaker with 50 mL of Water (g)
103.7	153.7

Data Table 3

Mass of Weighing Paper (g)	Mass of Weighing Paper and Table Salt (g)
0.5	5.5

### ◆ Analyze and Conclude

1. What is the mass of 50 mL of water? How did you find this mass?  
50 g; by subtracting the mass of the empty beaker from the mass of the beaker with 50 mL of water in it
2. Which rider on the balance should always be moved first when finding the mass of an object? Why?  
The middle (heaviest) rider should be moved first. This rider measures the largest unit of mass used.
3. What is the mass of the largest object your balance is able to measure?  
Answers may vary. Generally, 610 g is the largest mass that can be measured using a standard triple-beam balance.
4. What is the mass of the smallest object your balance is able to measure accurately?  
The smallest mass that can be measured accurately is 0.1 g.
5. After using your balance, how should it always be left?  
All the riders should be to the left, which should bring the pointer to zero.

## HOW TO USE A BALANCE *(continued)*

### ◆ Critical Thinking and Applications

1. Suppose you did not zero the balance before finding the mass of an object. How might that affect your measurement?

The reading would be inaccurate because you would be starting from a point below or above zero.

2. In this lab, you found the mass of 50 mL of water. Calculate the mass of 1 mL of water. (Do not use the balance.)

By dividing the mass of 50 mL of water by 50 g, students will find that the mass of 1 mL of water is 1 g.

3. Describe how you could find the mass of a certain quantity of milk that you poured into a drinking glass.

First find the mass of the empty drinking glass. Then pour in the milk and find the combined mass. Subtract the mass of the empty glass from the combined mass.

4. If you were baking a dessert and the recipe called for 250 g of sugar, how could you use the triple-beam balance to obtain this amount?

Place a piece of paper or a light food container on the balance and find its mass. Add 250 g to the mass of this object and set the riders for that amount. Slowly add sugar until the pointer balances on zero.

### ◆ More to Explore

Design a balance that finds mass by comparing the mass of a known object to the mass of an unknown object. Study the triple-beam balance used in this activity and think about how you could balance two or more objects. Construct your balance and use it to find the mass of an object. How could you improve your balance?

Student designs will vary, but they should mimic the action of a double-pan balance. Two holding devices may be attached to a lever that is balanced on a fulcrum, like a seesaw, or suspended from a fixed point, using string. For example, cans can be placed on the far ends of a ruler. The ruler must be positioned on a fulcrum at the ruler's midpoint. Or two pieces of identical cloth can be cupped to hold objects. These cloth holders can be suspended from a fixed hanger at an equal distance from the midpoint. Objects of known mass can be placed in one holding device, while small objects such as pennies or paper clips can be placed in the other device. When the two holders and their contents are level, both sides have equal mass. Specific suggestions for improvement may include using hanging devices with less friction or using holding devices that are equal in mass.

**LAB 1****LABORATORY INVESTIGATION**

## Finding Average Mass

**Key Concept:** Atomic mass is the average of the masses of all atoms of the same element.

**Skills Focus:** Inferring, predicting, measuring, calculating, graphing, designing experiments

**Time Required:** 40 minutes

### ◆ Pre-Lab Discussion

Atoms are made up of protons, neutrons, and electrons. The neutron and proton have approximately the same mass, and both masses are very large compared to the mass of the electron. An atom's total mass is the sum of the masses of all the protons and neutrons inside it. Since each proton and each neutron is assigned a mass of 1 atomic mass unit, a particular atom's mass is always a whole number. So why is the mass of the atom in the periodic table *not* a whole number? Atoms of an element all have the same number of protons but can have different numbers of neutrons. The atomic mass in a periodic table is the average mass of all the atoms of an element.

How do you figure out the atomic mass of an element? It's like finding the average mass of all your textbooks. Each book has a different mass. To get the average mass, you add the masses of the books and then divide the total mass by the number of books. In this investigation, you will devise a procedure to determine the average mass of another group of objects.

1. Why must each atom of an element always have the same number of protons?

**The number of protons in an atom defines its identity as an element. All atoms with the same number of protons have the same identity.**

2. The total mass of ten quarters is 55 grams. What is the average mass of a quarter?

**total mass/number of quarters =  $55.0 \text{ g}/10 = 5.5 \text{ g}$**

### ◆ Problem

**Alternate Materials:** You could use small objects other than pennies.

What is the average mass of an object in a group of similar objects?

### ◆ Possible Materials (per group)

balance  
pennies or other small objects  
forceps  
watch glass

**Teaching Tips:** Any group of similar objects can be used. Pennies are easy to work with, and they won't fall off the balance. Nuts, bolts, dominoes, and jacks also work well. Forceps and a watch glass will be useful for controlling objects that are likely to roll off the balance pan.

- ◆ **Safety**  Review the safety guidelines in the front of your lab book.

## FINDING AVERAGE MASS *(continued)*

### ◆ Procedure

1. Read through the entire lab before starting the investigation.
2. Working with a partner, plan a way to find the average mass of an object in a group of those objects. Consider the number of objects and their shape. What equipment will you need to measure the mass of each object? Will you need equipment to contain the objects?
3. Decide how to use the Data Table to record each object and its mass. Find the mass of at least ten objects to the nearest 0.1 g.
4. Write your procedure on a separate sheet of paper. Have the teacher approve your procedure before you carry out the investigation.

### ◆ Observations

Data Table

<i>Object</i>	<i>Mass</i>
1	2.8 g
2	2.9 g
3	2.8 g
4	3.0 g
5	2.8 g
6	2.9 g
7	3.1 g
8	2.7 g
9	2.8 g
10	2.8 g

The distribution of masses will vary somewhat between groups. Have students speculate on the distributions and how each will affect the overall result if the masses for all groups are combined. Like all statistics, if you have a bigger population sample, the precision of the average will increase.

Scientists use special equipment to measure the masses of more than  $10^{23}$  atoms to get the representative mass of an element. This gives an extremely accurate profile of the mass distribution of all the atoms of an element. An accurate profile gives a more exact value for the mass of an atom.

© Prentice-Hall, Inc.

### ◆ Analyze and Conclude

1. Add up the masses of all the objects.

Sum of all masses = 28.6 g

**FINDING AVERAGE MASS** (continued)

2. Calculate the average mass.

Average mass = sum of all masses / number of pennies = 28.6 g/10 pennies = 2.86 g/penny

3. Make a bar graph showing how many of the objects have identical mass. Use increments of 0.1 g in your graph.

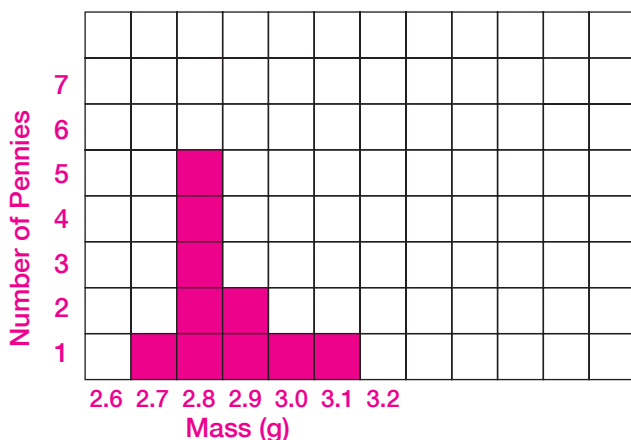

4. Were there more objects with masses greater than the average or with masses less than the average?

Answers will vary. For the sample data, there were six pennies with masses less than the average and four with masses greater than the average.

5. All the objects look identical. Why do you think some of the objects have more mass than others, although they are all the same size?

Answers will vary. Sample answer for pennies: Although the pennies may look the same, they may be made of different material, depending on the mint date. For example, in 1982 a zinc plug replaced much of the copper in a penny. Also, the copper in pennies oxidizes, and the added oxygen increases the mass. Some pennies are dirtier than others, which could change the mass.

**◆ Critical Thinking and Applications**

1. If you repeated this lab, what might you change in your procedure?

Answers will vary. Students might choose a different type of object. They might want to measure the mass of all the objects in one group instead of individually.

2. A small group of neon atoms has the following masses: 20% have 21 atomic mass units (amu) and 80% have 20 amu. What is the average mass of the neon atoms? Show your calculations.

$(20\% \times 21 \text{ amu}) + (80\% \times 20 \text{ amu}) = (0.20 \times 21) + (0.80 \times 20) \text{ amu} = 20.2 \text{ amu}$



### FINDING AVERAGE MASS *(continued)*

3. How does the mass you found in Question 2 compare to 20.1797 amu reported for neon in the periodic table?

The calculated mass is very close but not an exact match.

---

4. Do you think that the atomic mass for neon in the periodic table is more exact and closer to the true value than the answer to Question 2? Give a reason for your answer.

Sample answer: Yes, because the periodic-table value is based on averaging the masses of a much larger group of atoms.

---

---

---

### ◆ More to Explore

**New Problem** Would you get the same average mass if you used fifty of the same objects as you did when you used ten of these objects?

**Possible Materials** Use fifty of the objects you used in the previous lab.

**Procedure** Predict whether the average masses will be the same, greater, or less. On a separate sheet of paper, write a procedure you would follow to test your prediction. Have the teacher approve your procedure before you carry out the investigation.

**Observations** Make a data table and record your observations on a separate sheet of paper.

#### Analyze and Conclude

1. Compare the average mass for the fifty objects to the average mass of ten objects. Was your prediction accurate? If not, give a reason for the inaccuracy.

The values should be close but not exactly the same because of the same variability in objects observed previously.

---

2. Does finding the average mass of fifty objects produce a more correct value than finding the average mass of ten objects? Give a reason for your answer.

The more objects you use, the more complete picture of their masses you get. Therefore, the average mass of the fifty objects is likely to be more correct.

---

---

The statistics will vary somewhat. The value of the average mass depends on the condition of the pennies/objects. The value will be close but may not be exactly the same.

**LAB 2****LABORATORY INVESTIGATION**

# Testing for Hard Water

**Key Concept:** Hard water is a mixture of ions dissolved in water; the more ions present, the harder the water is.

**Skills Focus:** Observing, predicting, classifying, designing experiments, controlling variables

**Time Required:** 40 minutes

## ◆ Pre-Lab Discussion

Hard water is a common problem for many households. It can form chemical deposits that clog water pipes and damage water heaters and boilers. What causes hard water? No natural water source is 100% pure water. All sources contain other chemicals, such as calcium and magnesium compounds. These compounds form ions in water. Ions are single atoms or groups of atoms that carry an electric charge. The total amount of ions present in water is a measure of the hardness of the water.

When you add soap to hard water, the ions combine with the soap and form scum. Because some soap is being used to produce scum, fewer suds form. Therefore, you need to use more soap when you shower or wash your clothes. You can tell from the amount of soap suds how hard the water is.

In this investigation, you will test water and rate its hardness.

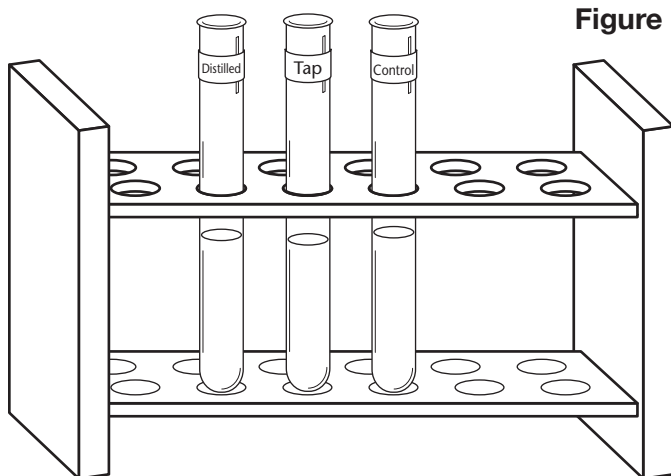

**Figure 1**

1. How does soap make it possible for water and oil to mix?

**A soap molecule has a polar end and a nonpolar end, so it attracts water (polar) and mixes with oil (nonpolar).**

2. Why are soap and the ions in hard water attracted to each other to form scum?

**The polar end of soap molecules attracts the charged ions. These ions combine with soap to form a new compound (scum).**

## ◆ Problem

**Advance Preparation:** You can make a standard sample of hard water by mixing 1 g of calcium chloride in 10 mL of distilled water. Prepare 200 mL of hard water for the lab.

How can you determine if water is hard?

Have some students bring a sample of tap water from home and have others get tap water from school. You could also use bottled water for comparison. Get a supply of hand soap (liquid or bar) or soap flakes. If students use bar soap or soap flakes, a pea-sized piece will be enough for a 10-mL sample. One drop of liquid soap is enough for a 10-mL sample.

## TESTING FOR HARD WATER *(continued)*

### ◆ Possible Materials *(per group)*

- distilled water
- tap water
- 3 or 4 test tubes
- test-tube rack
- 10-mL graduated cylinder
- plastic dropper
- 100-mL beaker
- bar soap
- liquid hand soap
- standard sample of hard water

Soap flakes can be used in place of liquid or bar hand soap, but you must make sure that this is soap and not detergent. Most detergents are sold as powders or flakes. Since detergents are formulated to eliminate problems from hard water, detergents are not usable for this investigation.

**Teaching Tips:** If you are also testing bottled water, the procedure will require four test tubes, and students should adjust data tables accordingly.

Distilled water makes lots of suds from soap; it is very soft water.

Student plans should include one sample size of water for all tests, one amount of soap for all tests, and a consistent way to mix the sample with soap (for example, shake ten times).

Students can gauge hardness from the height of the suds in the test tube and the relative amount of cloudiness. Letting the samples sit for 10 minutes accentuates the differences.

### ◆ Safety Review the safety guidelines in the front of your lab book.

Always clean up spilled water to prevent falls.

### ◆ Procedure

1. Read the entire lab before starting your investigation.
2. Working with a partner or group, plan how to test the hardness of water. Consider the following:
  - What water will you test?
  - What will you use as a control?
  - Use soap to test for hardness. What will you look for as evidence of hardness? Be sure to use the same amount of soap for each sample.
  - What observations will you record? You can either use the Data Table in Observations or develop your own data table on a separate sheet of paper.
3. Once you have decided what samples you will test, predict which sample will be the hardest and which the least hard. Give reasons for your predictions.

**Students' predictions will vary. They may be based on their experience with using different kinds of water; for example, observations about how sudsy the water becomes when they wash their hands.**

---



---

4. Write your procedure on a separate sheet of paper. Have the teacher approve your procedure before you carry out the investigation. Remember to wear your safety goggles and apron.

## TESTING FOR HARD WATER *(continued)*

### ◆ Observations

Data Table

<i>Water Type and Soap</i>	<i>Observations</i>	
	<i>Just After Mixing</i>	<i>10 min After Mixing</i>
<i>Distilled water</i>	Lots of suds fill the test tube; Water is clear.	Suds fill test tube and water is clear. Suds take a long time to dissipate.
<i>Tap water</i>	If the water is very hard, few suds will form and the water will be cloudy. If the water is not very hard, more suds will form and the water will be clearer.	If no suds were present before, none will be now. If suds were present, there will be fewer now. Cloudiness depends on amount of scum formed.
<i>Control</i> Standard sample of hard water (Distilled water plus calcium chloride)	Few suds; cloudy water	Few, if any, suds; cloudy water; Suds easily dissipate.

### ◆ Analyze and Conclude

1. How does the soap show that water is hard?

Because soap suds will not form in hard water, absence of soap suds clearly indicates hard water.

2. List samples in order of hardness, from most to least.

Order will vary; distilled water is always the softest. Answers should reflect students' data.

3. How do your results differ from your prediction? Explain what your results mean.

Answers will vary. Students should describe how the results differ from the prediction. Some students may be knowledgeable about water hardness if their local water supply is noticeably hard.

## TESTING FOR HARD WATER *(continued)*

### ◆ Critical Thinking and Applications

1. Did suds form in all the test tubes? If not, why?

Answers will vary. Some samples, such as the control, may have many ions in them, so they are very hard. Soap can't make suds in very hard water.

2. The control contained calcium chloride dissolved in distilled water. What ions are present in the control?

Calcium ions,  $\text{Ca}^{2+}$ , and chloride ions,  $\text{Cl}^-$ , are present.

3. What are the disadvantages of using hard water to do laundry?

Hard water would prevent the soap from dispersing in the water, so it can't work on the dirt in the clothes. Also, scum forms and may collect in places around the inside walls of the washing machine.

4. What do you have to do to turn hard water into soft water?

You need to remove the dissolved calcium and magnesium ions from the hard water to make the water soft.

### ◆ More to Explore

Check the labels of some laundry detergents and soaps and list the ingredients. Note any special directions about using the detergent. Use a chemical reference book to find out more about these chemicals. How does getting clothes clean in hard water differ from doing so in soft water? Write a procedure you could use to test your hypothesis. Have the teacher approve your procedure before you carry out your investigation. Remember to wear your safety goggles and apron.

**Detergents are designed to be active in all water conditions. They contain synthetic soap-like molecules made from alkene benzene sulfonic acid or phosphates. These compounds do not form scum in hard water, so they work better than soap in hard water. Students may design a procedure to compare how much detergent is necessary for getting clothes clean in different types of water. Or they might compare the effectiveness of soap versus detergents. Warn students to keep laundry detergent off their skin; it is very harsh.**

**LAB 3**

**LABORATORY INVESTIGATION**

# Determining Solubility

**Key Concept:** Solubility is a measure of how much of a given material will dissolve in a particular solvent under a determined set of conditions.

**Skills Focus:** Inferring, measuring, calculating, graphing

**Time Required:**  
40 minutes

## ◆ Pre-Lab Discussion

Solubility is how much of a solid can dissolve in a liquid. Suppose, for example, you stir salt (the solute) into a glass of water (the solvent) a little at a time. The salt dissolves until the saltwater solution is saturated. After that, added salt crystals will no longer disappear.

Now suppose you took an identical glass of water and made a saturated solution of sugar. You could stir in a lot more sugar than salt before the solution becomes saturated. In fact, you could tell the two samples apart by observing how much of each dissolves in the same amount of water. The water has to be the same temperature, however, or your results would not be comparable. The amount of sugar that could dissolve in cold water is different than the amount that can dissolve in the same amount of warm water.

In this investigation, you will determine the amount of a solute that can dissolve in water at different temperatures.

1. What is a solution?

**A solution is a homogeneous mixture of a solute dissolved in a solvent.**

---

2. What is a saturated solution?

**In a saturated solution, no more solute can be dissolved in the solvent.**

---

3. How do you know when a solution is saturated?

**More solute added to the solvent will not dissolve and will remain visible in the solvent.**

---

## ◆ Problem

How can you determine the solubility of a substance in water?

### ◆ Materials *(per group)*

- |  |                    |
|--|--------------------|
| small piece of paper, about<br>15 cm × 15 cm | 2 test tubes       |
| balance                                      | thermometer        |
| 25 g potassium nitrate                       | hot plate          |
| water  | two 250-mL beakers |
| 10-mL graduated cylinder                     | ice                |
| tongs  | spatula            |

**Alternate Materials:** You could substitute other nitrates for potassium nitrate, but they don't have as large a range of solubility over a wide temperature range.

**Teaching Tips:** Assign each student one temperature above room temperature and one below. The class as a whole should test a variety of different temperatures between 0°C and 100°C.

**DETERMINING SOLUBILITY** *(continued)*

◆ **Safety**  Review the safety guidelines in the front of your lab book.

Handle the thermometer carefully. If it breaks, tell the teacher. Use tongs or an oven mitt when handling hot objects. Wear your safety goggles and apron.

**◆ Procedure**

1. The teacher will assign you a high and a low temperature to use in the lab.
2. Use a balance to find the mass of the small sheet of plain paper. In the Data Table, record the mass of the paper.
3. Adjust the balance so that it registers 25 g more than the mass of the paper alone. Slowly and carefully add potassium nitrate to the paper until the balance is again level. In this way, you have poured out 25 g of potassium nitrate. Record this amount in the Data Table. Add and record the total mass of the paper and potassium nitrate.
4. Pour 10 mL of water into a test tube. Put the test tube in a half-filled beaker of water. Place the beaker on the hot plate. See Figure 1. Insert a thermometer in the test tube. You will need to hold the thermometer so that the end is in the water but not touching the bottom.
5. Heat the test tube in the water bath over the hot plate until the water reaches the high temperature assigned to you. **CAUTION:** Use tongs to hold the thermometer in the test tube. Try to maintain this temperature during the next step by adjusting the dial on the hot plate.
6. Use a spatula to put a small amount of the 25 g of potassium nitrate into the test tube. Stir very carefully with the thermometer. If the potassium nitrate dissolves completely, add a little more. Continue adding small amounts of potassium nitrate until no more dissolves and a few small grains settle to the bottom of the test tube. Now you have a saturated solution.
7. In the Data Table, record the exact temperature of the solution when it has become saturated.
8. Find the mass of the paper and the remaining potassium nitrate. Subtract this amount from the mass before dissolving to find the amount of potassium nitrate you used. Record the amount used in the Data Table.

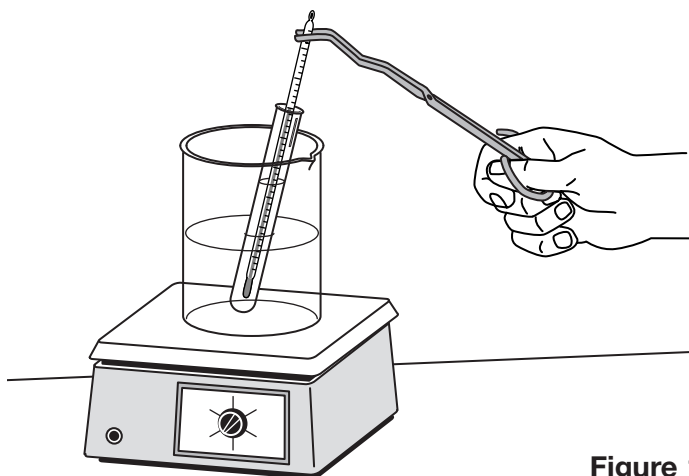
**Figure 1**

**DETERMINING SOLUBILITY** *(continued)*

9. Half-fill a beaker with ice. Pour 10 mL of water into another test tube. Set the test tube on the ice. Insert a thermometer so that the end is in the water but not touching the bottom. Cool the water until it reaches the second temperature assigned to you. Try to maintain this temperature during the next step by periodically removing the test tube from the ice.
10. Repeat Steps 6–8.
11. Report your data to the teacher, who will compile all the information obtained by the class. In this way, you will find out how much potassium nitrate dissolves in 10 mL of water over a wide temperature range.
12. Graph the class's results on the grid provided in Observations.

**◆ Observations****Data Table****Sample Data**

<i>Mass of paper</i>	4.3 g
<i>Mass of potassium nitrate</i>	25.0 g
<i>Mass of paper and potassium nitrate before dissolving</i>	29.3 g
<i>Temperature of heated solution when saturated</i>	100°C
<i>Mass of paper and potassium nitrate after saturation</i>	6.3 g
<i>Mass of potassium nitrate used to saturate</i>	23.0 g
<i>Temperature of cooled solution</i>	0°C
<i>Mass of paper and potassium nitrate before dissolving</i>	6.3 g
<i>Mass of paper and potassium nitrate after saturation</i>	5.0 g
<i>Mass of potassium nitrate used to saturate</i>	1.3 g



**DETERMINING SOLUBILITY** *(continued)*

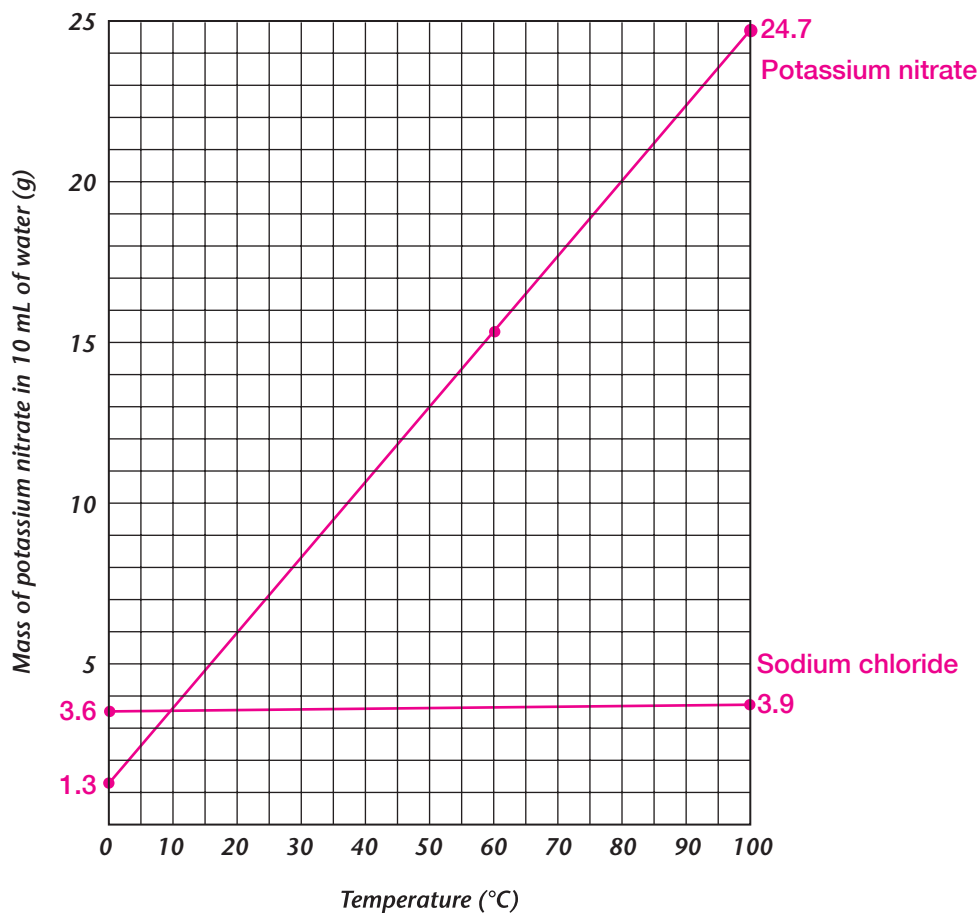

**◆ Analyze and Conclude**

1. What effect does temperature have on the amount of potassium nitrate that can dissolve in a given amount of water?

**More potassium nitrate can dissolve in warmer water.**

2. From your graph, predict how much potassium nitrate would dissolve in 10 mL of water at 60°C.

**Answers will vary somewhat. For the sample data, 15.3 g of potassium nitrate would dissolve.**

3. How much potassium nitrate do you think could dissolve in 100 mL of water at 60°C? Show your calculations.

**The volume of water increases by a factor of 10, so the amount of solute will increase by about the same factor. For the sample data, this will be 153 g of potassium nitrate, or ten times the amount in 10 mL of water at 60°C.**

**DETERMINING SOLUBILITY** *(continued)*

4. What temperature would 10 mL of water have to be for 14 g of potassium nitrate to just dissolve completely?

reading from the graph of the sample data, 54°C

---

**◆ Critical Thinking and Applications**

1. If the temperature of a saturated solution of potassium nitrate dropped, what would you see?

The solubility of potassium nitrate would decrease, and some would precipitate on the bottom of the test tube.

---

2. Based on the graph, how much potassium nitrate do you think would dissolve in 190 mL of water at 100°C? Show your calculations.

For the sample data, 24.7 g of potassium nitrate will dissolve in 10 mL of water at 100°C. Therefore,  $19 \times 24.7 \text{ g} = 469 \text{ g}$  of potassium nitrate will dissolve in 190 mL of water at 100°C.

3. Suppose you measured the solubility of potassium nitrate only at 10°C and at 90°C. Would this affect the accuracy of your solubility graph? Give a reason for your answer.

A graph of two points is a straight line. If the mathematical relationship is not linear and some curvature is actually present, the two data points won't show this relationship, and the graph would be inaccurate. In addition, the more data points you have, the less likely it is that measurement errors will result in an incorrect graph.

---

4. If 10 mL of a saturated solution of potassium nitrate cooled from 60°C to 10°C, how much potassium nitrate would be on the bottom of the test tube? Show your calculations.

15.3 g at 60°C minus 3.6 g at 10°C = 11.7 g

**DETERMINING SOLUBILITY** *(continued)***◆ More to Explore**

**New Problem** What is the solubility of sodium chloride under the same conditions as in this lab? Does its graph differ from the graph for potassium nitrate?

**Materials** Use the same equipment as in this lab.

**Safety** Handle the thermometer carefully. If it breaks, tell your teacher. Use tongs or an oven mitt when handling hot objects. Wear your safety goggles and apron.

**Procedure** Decide how, if at all, you should adjust the previous procedure to solve this new problem. Have the teacher approve your procedure before you carry out the investigation.

**Observations** Plot the data on the same graph in Observations.

**Analyze and Conclude**

1. How does the solubility graph for sodium chloride compare to the graph for potassium nitrate?

*Compared to potassium nitrate, more sodium chloride dissolves in water at 0°C, and less dissolves in water at 100°C. So the line has a much flatter slope.*

2. Use your graph to find the temperature at which sodium chloride and potassium nitrate have the same solubility.

*using the sample data, 10°C*

*Sodium chloride is much more soluble in water at lower temperatures than potassium nitrate is. But it is much less soluble than potassium nitrate at higher temperatures. Sodium chloride's solubility in water differs very little between 0°C and 100°C.*

**LAB 4****LABORATORY INVESTIGATION**

# Weight and the Force of Gravity

**Key Concept:** The force on a spring increases as the mass attached to it increases.

**Skills Focus:** Observing, inferring, predicting, measuring, calculating, graphing, forming operational definitions

**Time Required:** 40 minutes

## ◆ Pre-Lab Discussion

If you've ever seen astronauts floating in a spacecraft, you've observed that mass and weight are different properties. The astronauts' mass doesn't change, but their weight decreases so much that they appear to float.

Mass and weight are certainly different, yet they are related. The mass of an object is the amount of matter it contains. You can use a balance to measure mass. The weight of an object is the force of gravity on its mass. To measure weight, you can use a spring. Because weight is the downward force of gravity on an object, a weight on a spring stretches the spring. The greater the weight of the object, the more the spring stretches.

If known masses are attached to a spring, you can use the amount of stretch (weight) to compare the weights of the unknown masses. In this investigation, you will measure how much a spring stretches with different numbers of washers. You will use these data to find the relationship between mass and weight.

### 1. What is gravity?

**Gravity is the force of attraction between objects that have mass.**

### 2. How would your mass and weight change if you went to the moon, which has much less mass than Earth?

**Your mass would not change, but your weight would be less because of the lower gravity on the moon.**

## ◆ Problem

How can you measure the force known as weight?

## ◆ Materials *(per group)*

ring stand	clamp
large ring	2 large paper clips
spring	15 washers
meter stick	100-g mass

**Advance Preparation:** The springs must be able to support 100 g without permanent distortion. Test the springs with the washers you plan to use to be sure that they stretch enough. You may need to use larger or smaller washers.

**Alternative Materials:** Fishing sinkers can take the place of washers. If springs are not available, hang large rubber bands from the ring with a large paper clip. Note, however, that rubber bands stretch out easily.

**Teaching Tip:** Discuss student conceptions of weight and mass before the lab. Are mass and weight the same? When are they different? Why does a balance measure mass, while a spring measures weight? Use examples to show that mass is invariable, while weight is variable (on Jupiter, under water, etc.).

**Discuss the calculation used to answer Critical Thinking and Applications Question 3.**

**WEIGHT AND THE FORCE OF GRAVITY** (continued)

◆ **Safety**   Review the safety guidelines in the front of your lab book.

Wear safety goggles during this activity. To prevent slips or falls, immediately pick up any dropped washers.

◆ **Procedure**

1. Attach the ring to the ring stand and hang the spring from it. Clamp the meter stick to the ring stand, so that the 100-cm mark is on the tabletop and the spring is close to, but not touching, the meter stick. Bend the large paper clip into an S and hang it on the bottom of the spring. See Figure 1.
2. Note the number on the meter stick, to the nearest tenth of a centimeter, that is just even with the bottom of the spring. Record this reference point in Data Table 1.
3. Hang 5 washers on the paper clip and note the number on the meter stick that is just even with the bottom of the spring. Record this number in Data Table 1.
4. Repeat Step 3 with 10 washers and with 15 washers on the paper clip.
5. If you removed washers five at a time, predict whether the spring's length will be the same or different from its length when you added washers. Give a reason for your prediction.

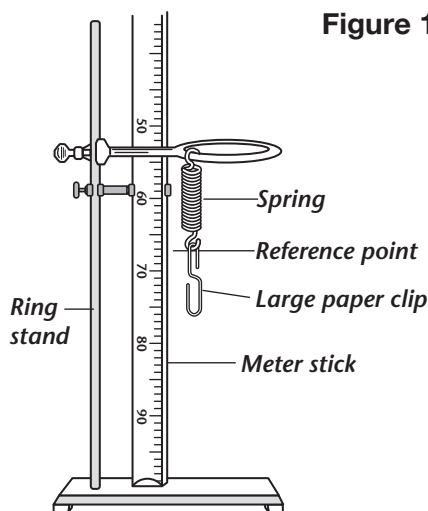

**Predictions will vary. Some students may predict that the spring will become stretched out. They will discover during the lab that readings are about the same.**

6. Remove 5 washers. Note the number on the meter stick that is just even with the bottom of the spring. Record the number in Data Table 1. Do this twice more, removing 5 washers each time.
7. To find the change in the length of the spring, find the difference between each particular meter stick reading and the previous reading. Calculate this change to complete Data Table 1.
8. Note the reference point, as you did in Step 2. Record this number in Data Table 2.
9. Hang a 100-g mass from the spring and note the number on the meter stick that is just even with the bottom of the spring. Record this number in Data Table 2. Calculate and record the change in length of the spring.

**WEIGHT AND THE FORCE OF GRAVITY** *(continued)*

◆ **Observations**

Be sure students understand how to calculate the numbers in Column 3 from those in Column 2.  
Example:  $68.2 - 67.5 = 0.7$

**Data Table 1**

<i>Number of Washers</i>	<i>Reading of Meter Stick (cm)</i>	<i>Stretch Length (cm) (Change in Length of Spring Compared to Previous Measurement)</i>
0	67.5	
5	68.2	0.7
10	68.9	0.7
15	69.6	0.7
10	68.9	0.7
5	68.2	0.7
0	67.5	0.7

Sample Data: The change in the length of the spring with the 100-g mass attached will vary from spring to spring.

**Data Table 2**

<i>Reference point (cm)</i>	67.5
<i>Meter stick reading with 100-g mass (cm)</i>	77.5
<i>Change in length of spring (cm)</i>	10.0

◆ **Analyze and Conclude**

- Use the grid at the right to graph your results in Data Table 1. Label the vertical axis *Stretch length (cm)* and the horizontal axis *Number of washers*.

Graphs should be close to a straight line.

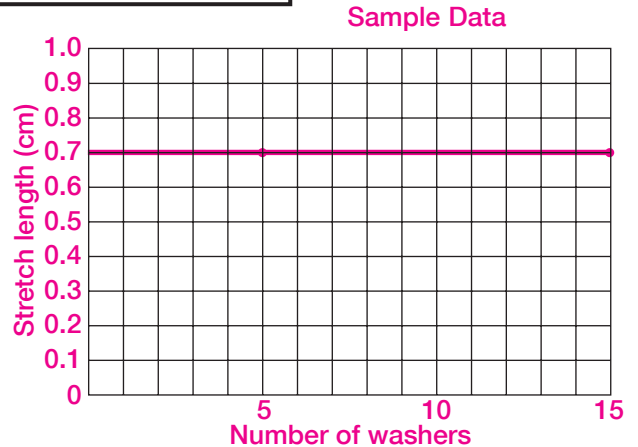

- How much did the length of the spring change as each group of 5 washers was added?

Answers will vary, but should show a fairly consistent increase for every 5 washers added.

- How much did the length of the spring change as each group of 5 washers was removed?

Answers will vary, but should show a fairly consistent decrease for every 5 washers removed.

**WEIGHT AND THE FORCE OF GRAVITY** *(continued)*

4. How do your answers to questions 2 and 3 compare? Explain why they are the same or different.

The increase in length as 5 washers are added should equal the decrease in length as 5 washers are removed. The weight of those washers is the same, and that is what the spring measures.

5. How does the shape of your graph illustrate your answers to questions 2 and 3?

The graph is a straight line. This shows that the stretch increased and decreased by the same amount each time as the same number of washers was added or removed.

**◆ Critical Thinking and Applications**

1. What forces act on the objects you attach to the spring?

Gravity is the downward force on the objects. The spring exerts an upward force. If the object is at rest, the two forces are equal and in opposite directions.

2. In terms of force, explain why the spring stretched as more washers were added.

The mass increased as more washers were added, so the force of gravity on the washers increased. The force of the spring also increased, shown by its greater stretch. The longer it stretches, the more upward force it exerts.

3. In Data Table 2, you put a 100-g mass on the spring and recorded the amount the spring stretched. From your graph, you know that mass and stretch length increase together at a steady rate. Use this information to calculate the mass of 5 washers. What is the mass of 1 washer?

Answers will vary depending on the washer size. Sample answer:

If 5 washers stretch 0.7 cm and 100 g stretch 10 cm, then 5 washers stretch  $0.7 \div 10 = 0.07$  of the 100-g stretch. Then  $0.07$  of 100 grams = 7 g. So 5 washers = 7 g; 1 washer =  $7 \div 5 = 1.4$  g.

4. Why do you think a spring balance might give different results at different times?

Springs may not always stretch by the same amount when weights are added, particularly if they have been overstretched. They may also be affected by temperature.

**◆ More to Explore**

Does an object weigh more, less, or the same under water as it does in air? Write a procedure you would follow to answer this question, and predict the results. Have the teacher approve your procedure before you carry out the investigation. Was your prediction correct? If not, do some research to find out why you had surprising results.

One procedure is to weigh an object dry, place a beaker of water under the spring scale, and weigh the object when it's submerged. An object under water will weigh less than an object in the air, because of the buoyant force of the water. Students might find it interesting that astronauts train in water as a way to simulate weightlessness.

**LAB 5** **LABORATORY INVESTIGATION**

# Pulleys as Simple Machines

**Key Concept:** The number and arrangement of pulleys determine the mechanical advantage.

**Skills Focus:** Observing, making models, measuring, calculating

**Time Required:** two periods of 45 minutes; a possible breakpoint is after Step 5.

## ◆ Pre-Lab Discussion

Pulleys are simple machines that lift objects in a variety of ways. The simplest kind of pulley is a grooved wheel around which a rope is pulled. Pulleys can change the direction of an applied force. For example, a pulley fixed to the top of a flagpole lets you raise a flag *up* by pulling *down*.

A combination of fixed and movable pulleys is a pulley system, or block and tackle. A pulley system multiplies input force to lift heavy objects. Pulley systems are commonly seen on construction sites.

In this investigation, you will use different pulley systems and determine the mechanical advantage of each.

1. Define the mechanical advantage of a machine.

**The mechanical advantage of a machine is the number of times a machine multiplies a force exerted on it.**

2. Why is a pulley considered a machine?

**A machine makes work easier by changing the direction or amount of force needed to accomplish a task. Pulleys and pulley systems do both of these.**

## ◆ Problem

**Advance Preparation:** Cut 1 m of fishing line for each group.

How do pulleys help raise objects? How can you find the actual mechanical advantage of a pulley or pulley system?

**Alternative Materials:** If standard 500-g masses are not available, substitute large washers tied together that approximate the same mass.

## ◆ Materials *(per group)*

- 2 single pulleys
- 2 double pulleys
- nylon fishing line, 1 m
- ring stand
- large ring
- 1,000-g spring scale
- 500-g mass

**Teaching Tips:** Have students refer to the section on pulleys in their textbook before performing the lab.

**In most cases, the scale spring stretches somewhat before the mass itself begins to move. Tell students to pull down on the scale until the mass just starts to move, then take the reading on the scale.**

**Some students may have trouble visualizing and setting up the complex pulley systems. Have a model of each pulley system available for students to inspect.**

- ## ◆ Safety Review the safety guidelines in the front of your lab book.

**The weight of a 500-g mass is approximately 5 N.**



**PULLEYS AS SIMPLE MACHINES** *(continued)*

**◆ Procedure**

1. Calibrate the spring scale so that it reads zero when no masses are attached to it.
2. Find the weight of the mass you are using by attaching it directly to the spring scale. Record this weight in the Data Table in Observations as the output force for all the pulley arrangements.
3. Set up a single fixed pulley as shown in Figure 1. Pull down on the spring scale to lift the mass. The reading on the scale shows the amount of input force needed to lift the mass. Record this number in the Data Table.
4. Set up a single movable pulley as shown in Figure 2. Lift the mass by pulling up on the spring scale. The reading on the scale shows the amount of force needed to lift the mass. Record this number in the Data Table.
5. Set up the single fixed and single movable pulley system shown in Figure 3. Measure the amount of force needed to lift the mass and record it in the Data Table.
6. Set up the pulley systems shown in Figures 4 and 5. For each pulley system, measure the amount of force needed to lift the mass and record it in the Data Table.
7. Calculate the actual mechanical advantage for each pulley and record it in the Data Table.

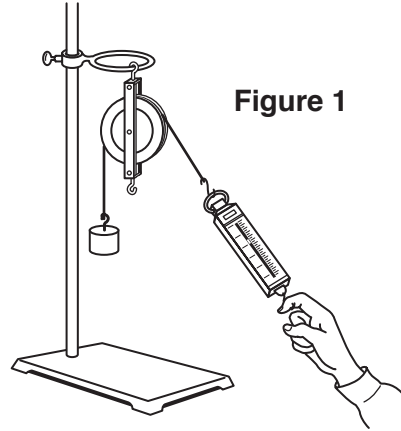

**Figure 1**

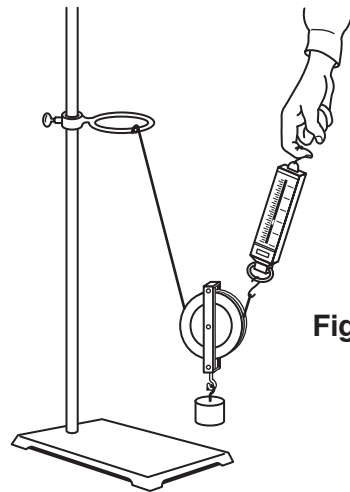

**Figure 2**

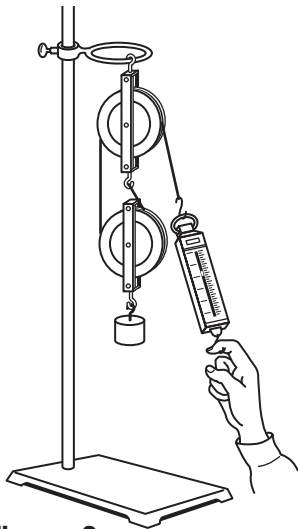

**Figure 3**

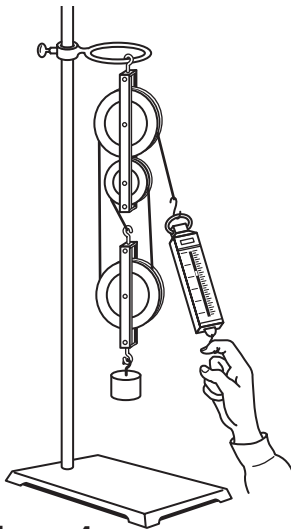

**Figure 4**

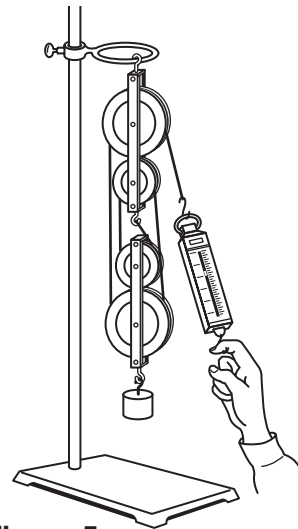

**Figure 5**

© Prentice-Hall, Inc.

**PULLEYS AS SIMPLE MACHINES** *(continued)***◆ Observations****Data Table****Sample Data**

<b><i>Pulley Arrangements</i></b>	<b><i>Output Force (O)</i></b>	<b><i>Input Force (I)</i></b>	<b><i>Actual Mechanical Advantage (O ÷ I)</i></b>
<i>Single fixed</i>	5 N	5 N	1
<i>Single movable</i>	5 N	2.5 N	2
<i>Single fixed and single movable</i>	5 N	2.5 N	2
<i>Double fixed and single movable</i>	5 N	1.7 N	3
<i>Double fixed and double movable</i>	5 N	1.3 N	4

**◆ Analyze and Conclude**

1. Was there a difference in the mechanical advantages you calculated for the single fixed pulley and the single movable pulley? Give a reason for your answer.

**Yes. The single fixed pulley has an ideal mechanical advantage of 1; the ideal mechanical advantage of the single movable pulley is 2. Actual mechanical advantage for these pulleys will probably be somewhat different because of friction and measurement error.**

2. As you added pulleys to the system, what happened to the amount of input force needed to raise the mass?

**Less input force was needed with more pulleys.**

3. What factors determine the mechanical advantage of pulley systems?

**The number and arrangement of the pulleys determine what the mechanical advantage will be.**

**◆ Critical Thinking and Applications**

1. If a simple machine has a mechanical advantage of 1, input force is not multiplied. Which type of pulley has an ideal mechanical advantage of 1? What is the practical use of this pulley?

**The single fixed pulley has an ideal mechanical advantage of 1. Its practical use is to change the direction of effort.**

**PULLEYS AS SIMPLE MACHINES** *(continued)*

2. To determine the ideal mechanical advantage of a pulley or pulley system without calculations, count the number of sections of rope that support the weight. The end section, which is attached to the spring scale, counts as a supporting section *only when pulled upward*. Using Figures 1 through 5, determine the number of supporting rope sections for each type of pulley.

- a. Figure 1:   1                        c. Figure 3:   2                        e. Figure 5:   4    
 b. Figure 2:   2                        d. Figure 4:   3

3. Do the values from Question 2 agree with the actual mechanical advantage calculated for the Data Table? Why or why not?

**Mechanical advantage for a pulley system is the same no matter how it is calculated. However, measurements of actual mechanical advantages will vary because of friction and measurement error.**

4. Draw an arrangement of two double pulleys that would give you a mechanical advantage of 6.

**Diagrams should show six supporting sections of rope.**

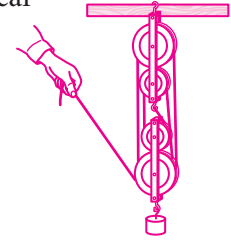

5. When using any simple machine, you never get something for nothing. Although the amount of input force needed to lift a mass is usually less in a pulley system, something else increases. What must increase as the input force decreases?

**The distance through which the input force moves increases.**

6. Explain your answer to Question 5 in terms of work input and work output.

**In a machine, work output can never be greater than work input. Because work input is input force times distance, if the input force decreases, the distance must increase.**

**◆ More to Explore**

In this investigation, you calculated mechanical advantage by dividing the output force by the input force. How could you use distances moved by the output and input forces to calculate mechanical advantage? Write a procedure you would follow to answer this question. Have the teacher approve your procedure before you carry out the investigation. How do these mechanical advantages compare with the ones you calculated earlier? Is one method better than the other for calculating mechanical advantage?

**If the input force and the output force move the same distance, the pulley system will have a mechanical advantage of 1. If the input force moves a greater distance than the output force moves, the pulley will have a mechanical advantage greater than 1.**

**LAB 6** **LABORATORY INVESTIGATION**

# Winding Up With Wind

**Key Concept:** A windmill can convert wind energy to mechanical energy.

**Skills Focus:** Making models, communicating, measuring, calculating, designing experiments

**Time Required:** 60 minutes to design and construct the windmill; 30 minutes to test its power

## ◆ Pre-Lab Discussion

Wind power is an ancient energy source. The earliest ships used the wind to carry them across seas. The first windmills were built in Persia (now Iran) in the sixth century A.D. They raised water from rivers. Later, windmills were used to turn a large stone wheel that ground grains.

Today, huge windmills, or wind turbines, generate electricity. The wind turbines are grouped in clusters called wind farms. Most wind farms are in California, located in windy mountain passes. California wind farms produce enough electricity to power all the homes of San Francisco. By the middle of the twenty-first century, experts think wind power could supply up to one fifth of the electricity used in the United States.

In this investigation, you will design blades for a windmill, build a model windmill, and measure its power output.

1. What kind of energy does wind have? Give a reason for your answer.

*Wind has kinetic energy because wind is moving air.*

---

2. How do you calculate power?

*Divide the amount of work done by the amount of time to do the work.*

---

## ◆ Problem

**Alternative materials:** A half-gallon milk container may be used as a windmill base. A hair dryer can be used instead of an electric fan to produce wind.

How can you design a windmill and test its power output?

## ◆ Possible Materials *(per group)*

- |                  |               |
|------------------|---------------|
| windmill base    | thumbtacks    |
| electric fan     | string        |
| scissors         | cloth         |
| poster board     | sandpaper     |
| cardboard        | thread        |
| balsa wood       | paper clips   |
| white glue       | stopwatch     |
| masking tape     | meter stick   |
| transparent tape | balance       |
| pushpins         | plastic straw |

**Advance Preparation:** Make a simple windmill base for each group. For each base, you will need an empty wood spool, a piece of plastic straw about 1 cm longer than the spool, a 2-inch #10 sheet-metal screw, and a 6-inch piece of two-by-four. Put the screw through the straw, and the screw and straw through the spool. Attach the screw to the narrow side of the two-by-four at one end, until it tightens against the piece of straw. The spool should turn freely.

Gather miscellaneous craft supplies that students can use to construct their windmills.

**WINDING UP WITH WIND** *(continued)*

◆ **Safety**  Review the safety guidelines in the front of your lab book.

Keep your fingers and other objects away from the moving blades of the fan.

Teaching Tips: Use small, battery-powered fans, if they are available, to produce wind in Step 5.

If you want to provide low-temperature glue guns, set up one or two stations where they are available.

◆ **Procedure**

**Part A: Design Blades**

1. Brainstorm a list of features that you need to consider in designing windmill blades. Look at pictures of different types of windmills, both old and modern in design. See Figure 1.
2. Choose the materials you will use for your windmill blades.
3. Design the blades for your windmill. (Hint: Consider the tilt of each blade.) On a separate sheet of paper, draw and describe how you will construct the blades and attach them to the windmill base. Have the teacher approve your design.
4. Construct your windmill blades and attach them to the base.
5. Try out the windmill, using an electric fan for wind. Hold the windmill about 30 cm from the fan.

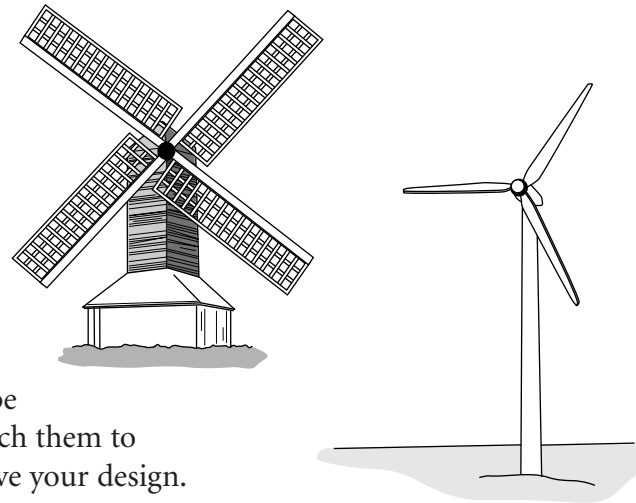

Figure 1

**Part B: Measure Power Output**

6. Tape a piece of thread, about 75 cm long, on your windmill's spool. Attach a paper clip to the other end of the string, as shown in Figure 2.
7. Place your windmill at the edge of your lab bench so that the paper clip is suspended in air. See if your windmill can lift the paper clip by winding up the thread on the spool.
8. Add more paper clips until you reach the maximum capacity for your windmill.
9. Measure the length of the thread, from the spool to the top of the paper clips. Record this length in the Data Table on the next page. Use a stopwatch to time how long it takes to lift the paper clips. Record the time.
10. Remove the paper clips and find their mass. Record the mass in the Data Table.

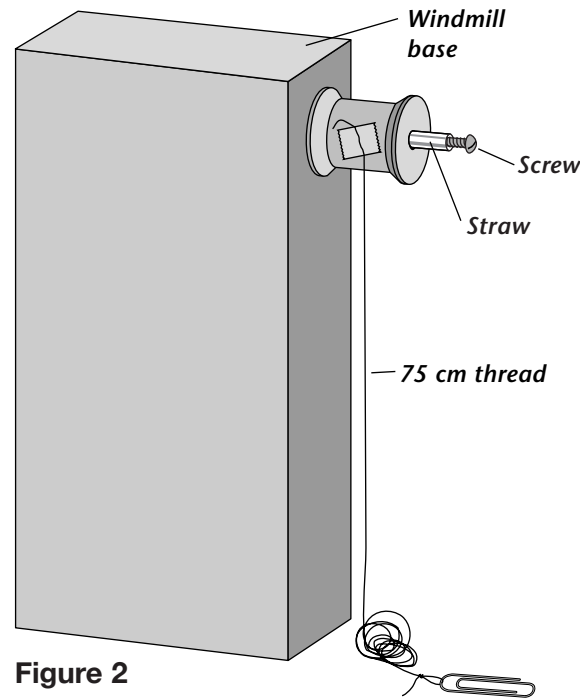

Figure 2

© Prentice-Hall, Inc.

## WINDING UP WITH WIND *(continued)*

### ◆ Observations

#### Data Table

#### Sample Data

<i>Length of thread</i>	75 cm
<i>Time for paper clips to be lifted</i>	5.9 s
<i>Mass of paper clips</i>	4.1 g (3 large paper clips)

Have a utility knife handy to help students with tricky cuts if they are using balsa wood. Make these cuts yourself.

Students may need to give the blades a slight push to get them started, but then they should turn on their own.

### ◆ Analyze and Conclude

1. Calculate the potential energy that the paper clips gained when they were lifted. Use the formula

$$\text{Gravitational potential energy} = \text{Mass (g)} \times \text{Gravitational acceleration (980 cm/s}^2) \times \text{Height (cm)}.$$

Divide your results by 10,000 and the units of your result will be mJ (millijoule, a thousandth of a joule).

**Answers will vary. The cgs unit for energy is the erg. Since students will not be familiar with this unit, they should convert their result to millijoules.**

**Sample calculation:  $PE = (4.1 \text{ g} \times 980 \text{ cm/s}^2 \times 75 \text{ cm})/10,000 = 30.1 \text{ mJ}$**

2. Calculate the power that gave the paper clips this energy. Use the formula

$$\text{Power} = \text{Work (mJ)} \div \text{Time (s)}.$$

The units of your result will be mW (milliwatt, a thousandth of a watt).

**Answers will vary. Sample calculation:  $P = 30.1 \text{ mJ} \div 5.9 \text{ s} = 5.1 \text{ mW}$**

3. Did your design work well? Which features of your design do you think were most important?

**Answers will vary. The most important design aspects of the blades are tilt and balance. If the blades are not tilted, there is no force pushing them to the side. If the blades are unbalanced, unnecessary friction results as the spool bangs around on the axle.**

---



---

## WINDING UP WITH WIND *(continued)*

### ◆ Critical Thinking and Applications

1. Was gravitational potential energy the only kind of energy that the paper clips got from the windmill? Give a reason for your answer.

*The paper clips moved as they were lifted, so they had kinetic energy as well.*

---

---

---

2. Look at the fan you used in the investigation, especially at its blades. Could it be used for a windmill? How could you prove this?

*Yes, the fan could be used as a windmill. You could prove this by exposing the fan to a strong wind, perhaps from another fan, and the fan blades would turn.*

---

---

---

3. In terms of energy conversion, what is the difference between an electric fan and a windmill that generates electricity?

*An electric fan converts electrical energy into kinetic energy, and a windmill that generates electricity converts the kinetic energy of the wind into electrical energy.*

---

---

---

### ◆ More to Explore

Try to improve your windmill by changing one feature of your design. Have the teacher approve your new design before you build it. Construct your new design and test your windmill as you did before. Compare your new results to those of your original design. Which generated more power?

*Depending on students' original design, they might change the number of blades, the material of which the blades are made, the tilt of the blades, or the balance of the blades. The power test will improve if the windmill is more effective.*

**LAB 7****LABORATORY INVESTIGATION**

# Investigating Soils and Drainage

**Key Concepts:** Soil permeability varies depending on the soil's composition. Relative permeability can be determined by measuring how quickly water passes through soil.

**Skills Focus:** Observing, making models, measuring, designing experiments, controlling variables

**Time Required:** 50 minutes

## ◆ Pre-Lab Discussion

Suppose that your community has a new soccer field, but it is hard to find a place to park. Many people park on the grass, which is now a muddy mess. Why didn't the water that created the mud just run off the land or soak into the soil? You think the answer to this problem lies in the soil. Different types of soil allow water to drain differently. Sandy soil drains differently from soil containing a lot of clay or soil that doesn't have much sand or clay. In this investigation, you will test how fast water drains through different types of soil.

1. What is soil made of?

Soil is a mixture of rock particles, minerals, decayed organic material, air, and water.

2. The size of soil particles gives soil its texture. List the four major types of soil particles in order from largest to smallest.

gravel, sand, silt, clay

## ◆ Problem

**Advance Preparation:** For the sake of time and safety, cut the bottles before the lab. Cut the tops off half the bottles and the bottoms off the other half. Punch a hole that will be above the water level and below where the two bottles meet.

How fast does water drain through different types of soil?

## ◆ Possible Materials (per group)

- 4 plastic 2-L soft-drink bottles with bottoms removed
- 4 plastic 2-L soft-drink bottles with tops cut off and a hole punched high in the side
- 4 pieces of gauze or cheesecloth, about 8 cm × 8 cm
- 4 rubber bands
- potting soil
- sand
- clay mixed with soil
- gravel mixed with soil
- plastic container, at least 1-L
- timer or watch
- permanent marker or wax pencil
- graduated cylinder or metric measuring cup, 100-mL

To ensure uniform initial dryness of the soils, heat the samples at a low temperature on a pan in an oven or let them dry in an area with low humidity.

**Alternative Materials:** Use large plastic or metal funnels instead of the upper bottle. Substitute coffee filters for cloth.

**Teaching Tips:** A good volume to mark on the side of the lower bottle is 500 mL. Students should fill the upper bottle about half full of soil and pat it lightly.

Students should plan to pour considerably more than the marked volume of water through the setup; the soil will absorb and retain some water.



**INVESTIGATING SOILS AND DRAINAGE** *(continued)*

◆ **Safety**  Review the safety guidelines in the front of your lab book.

Wear safety goggles and lab aprons throughout the activity. To prevent slips or falls, wipe up spills immediately.

Encourage students to use consistent quantities of all materials and to use metric measurements.

◆ **Procedure**

1. Read through the entire lab before carrying out your investigation.
2. Design a way to compare how quickly water flows through different soils. Figure 1 shows one possible setup. Write your procedure on a separate sheet of paper. Your procedure should address the following questions:

- What types of soil will you test?
- How much soil and water will you use?
- How will you pour the water: quickly and all at once, or more slowly and continuously?
- When will you start and stop timing?
- What variables will you control?

3. Predict which soil will drain most slowly and which soil will drain most quickly. Give reasons for your predictions.

Students may predict that gravel will drain most quickly because of the air spaces between the particles of gravel. Similarly, students may think clay soil will drain most slowly because the clay particles are so small that they don't allow much space between particles.

4. Have the teacher approve your procedure before you carry out the investigation.
5. Fill in the first column of the Data Table in Observations. Record your data in the second column.

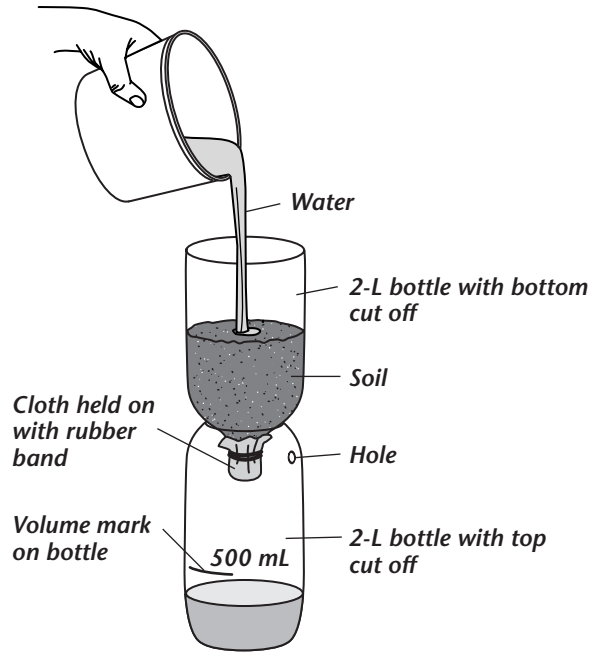

**Figure 1**

**INVESTIGATING SOILS AND DRAINAGE** *(continued)*

**◆ Observations**

**Data Table**

<i>Soil Type</i>	<i>Draining Time</i>

**Sample Data**

Data should show that a gravel/soil mixture drains most quickly, followed by sand, potting soil, and clay soil.

**◆ Analyze and Conclude**

1. Describe what happens to the water from the time you pour it into the soil until the time it drains into the plastic bottle.

*The water moves through the spaces between the soil grains. The spaces are connected, which allows the water to pass through the soil.*

2. Through which soil did water drain the fastest? Why do you think this happened?

*If students tested the gravel/soil mixture, they should find that water passed fastest through this material. The water can pass relatively quickly through the large spaces between the pieces of gravel.*

3. Do your results agree with your predictions? If they do not, explain why you think they don't agree.

*Results may not agree with predictions because students may not have been considering grain size in their predictions. Procedural factors, such as inconsistency in pouring the water, packing some soils too tightly, and using soils too similar to one another, may also have accounted for disagreement between predictions and results.*

4. What was most surprising about your results?

*Answers will vary. Students may have been surprised by how quickly or how slowly water traveled through the different soils and by how close or far apart the draining times were for different soil types.*

## INVESTIGATING SOILS AND DRAINAGE *(continued)*

### ◆ Critical Thinking and Applications

1. Why did water drain through the soils at different rates?

The soils differ in particle size and amount of space between the particles. Water can move through larger spaces faster than through smaller ones.

2. If you wanted to test other soils, what might you change in your experimental procedure?

Students might suggest having more samples of each soil type and running more trials.

3. Why do you think people put gravel on parking lots?

Gravel particles are relatively large, so gravel has relatively large spaces between the particles through which water can travel quickly. Water would drain quickly through the gravel and would not gather in puddles.

4. Think of what happens to rain that lands on a paved parking lot. What would be an advantage of paving a lot? What would be a disadvantage?

An advantage is that the lot would not become muddy. A disadvantage is that water would not drain through the paving material; any depression would contain standing water.

5. Suppose another sports field is being built. What kind of soil should be used for the best drainage? Give a reason for your answer.

A soil with lots of sand would produce less mud after a rain because water would drain through it more quickly. Students may also suggest including some gravel in the soil to improve drainage. Too much gravel, however, might interfere with the growth of the grass.

### ◆ More to Explore

Drainage is only one of many considerations when building a sports field. Another concern is how well grass will grow on the field. Is the soil that drains the best able to support a healthy crop of grass? What soil would be best to use for a new field? On a separate sheet of paper, write a procedure to answer these questions. Have the teacher approve your procedure before you carry out your investigation. Be sure to wear safety goggles and a lab apron.

Students should use the same soils as before and find out how well grass grows in each. Plastic cups or margarine tubs are adequate containers in which to grow grass. Students may suggest using sod instead of growing grass because most sports fields use sod. Sod will require containers with a larger area such as baking pans. Be sure students consider the criteria they will use to evaluate the effectiveness of the soil in supporting grass.

**LAB 8****LABORATORY INVESTIGATION**

# The Daily Grind

**Key Concept:** The amount of rock erosion that occurs through abrasion depends on time and the properties of the rock.

**Skills Focus:** Making models, observing, measuring, interpreting data

**Time Required:** 45 minutes

## ◆ Pre-Lab Discussion

A river or stream is more than just water in motion. Such moving bodies of water also carry along rocks and other materials, which change as they move. One kind of change is called mechanical weathering. As the water moves, it repeatedly tosses the rocks against one another and against the sides of the streambed. Each day, little by little, the rocks are ground into smaller and smaller pieces in a process called abrasion. Abrasion is one cause of the mechanical weathering of rocks.

In this investigation, you will model one way that abrasion causes the erosion of rocks. You will also find out how different kinds of rocks are affected by this process.

1. What provides the energy for the abrasion of rocks by rivers and streams?

**Water at higher locations possesses potential energy because of the force of gravity. As the water moves down a slope, the potential energy changes into kinetic energy, and some of this energy wears down the rocks.**

## ◆ Problem

How do time and the properties of specific rocks affect the way abrasion weathers rocks?

## ◆ Materials *(per group)*

balance  
 large plastic spoon  
 100-mL graduated cylinder  
 plastic jar, approximately 500 mL,  
 with screw-on lid  
 limestone chips, pre-soaked  
 granite chips, pre-soaked  
 rock salt, coarse (dry)  
 fine wire screen  
 paper towels  
 water  
 watch or clock with second hand  
 graph paper  
 wide-mouthed plastic jar,  
 approximately 1 L  
 newspapers  
 paper cups

**Advance Preparation:** The limestone and granite chips must be soaked for at least 1 hour before the lab. The rock salt must be dry at the beginning of the lab. Using “solar salt,” a form of rock salt used in water softening systems, usually gives better results than using crushed rock salt. For optimal results, use rock chips that are about 10 mm in length. Use only fresh rock chips at the outset of the lab.

**Teaching Tips:** Determine in advance whether any students will carry out the More to Explore activity. They will need to collect the runoff water from each type of rock carefully, being sure to clean all the equipment between uses.

**Music with a regular beat** can help students maintain a consistent rhythm as they shake the rocks. Stress also that to control variables, students must always determine the mass of limestone and granite with the rocks damp but not dripping.

**Alternative Materials:** Bluestone chips may be used in place of granite and marble chips may be used in place of limestone.

**THE DAILY GRIND** *(continued)*

◆ **Safety**  Review the safety guidelines in the front of your lab book.

Use caution in handling any glass equipment. Do not touch broken glass. Report any breakage to your teacher.

**◆ Procedure****Part A: Modeling Rock Erosion Over Time**

1. Cover your work area with newspaper in case of spills. Obtain two large spoonfuls of pre-soaked limestone chips. Dab them briefly with a paper towel to remove any dripping water. Then use the balance to find the initial mass of the rocks, and record it in Data Table 1. (*Hint:* Find the mass of a dry container such as a paper cup, find the mass of the container plus the rocks, and then subtract to find the mass of the rocks.)
2. Observe the appearance of the rock chips, and record your observations on a separate sheet of paper. Read over the rest of the procedure for Part A. Then, on the same sheet of paper, write a prediction for the way the rocks will change as they are weathered mechanically.
3. Place the rock chips in a plastic jar with a screw-on lid. Add 250 mL of water. Cover the jar, and seal it tightly.
4. Decide on the motion with which you will shake the jar, for example, up and down. You must use that same shaking motion throughout this lab. Shake the jar for exactly 3 minutes.
5. Place a fine wire screen over a second, wide-mouthed jar. Pour the rocks and water onto the screen, letting the water flow into the wide-mouthed discard jar. Be careful not to lose any chips. Briefly dab the wet chips with a paper towel to remove any dripping water. Then measure and record the mass of the rock chips.
6. Return the rocks to the first jar, and repeat Steps 4 and 5 three times. You should have a total of five mass readings in Data Table 1.
7. Observe the appearance of a few of the rocks. Record your observations on a separate sheet of paper.

**Part B: Comparing the Erosion of Different Kinds of Rocks**

1. In Part B, you will follow the overall procedures from Part A, but you will shake each type of rock for one 3-minute period only. Use Data Table 2 to record the results for Part B.
2. For limestone, find the initial mass of the chips you used in Part A by reading the mass at time 0 in Data Table 1. Record that mass as the original mass of the limestone chips in Data Table 2.

**THE DAILY GRIND** *(continued)*

3. Find the mass of the limestone chips after 3 minutes in Data Table 1, and record this in Data Table 2 as the Final Mass of the limestone chips.
4. Obtain two spoonfuls of pre-soaked granite chips, dab them briefly with a paper towel to remove excess water, and then find their initial mass. “Weather” the rocks by shaking them for 3 minutes, dab them briefly with a paper towel, and then find their final mass. Record your data in Data Table 2.
5. Obtain two spoonfuls of dry rock salt chips, and find their initial mass. “Weather” them by shaking for 3 minutes. Dab them dry with a paper towel, and then find their final mass. Record your data in Data Table 2.
6. For each type of rock in Data Table 2, find the mass of the rocks lost to weathering by subtracting the final mass from the original mass. Record the results in the fourth column of the data table.
7. For each type of rock in Data Table 2, determine the percent of change in mass using the equation below. Enter the results in the last column of your data table.

$$\frac{\text{mass lost to weathering}}{\text{original mass}} \times 100\% = ?\%$$

**◆ Observations**

**Data Table 1**

<i>Weathering Time (min)</i>	<i>Mass of Rocks (g)</i>
0	54.5
3	54.3
6	54.1
9	54.0
12	53.9

**Data Table 2**

<i>Type of Rock</i>	<i>Original Mass of Rocks (g)</i>	<i>Final Mass of Rocks (g)</i>	<i>Mass of Rocks Lost to Weathering (g)</i>	<i>Percent of Change</i>
<i>limestone</i>	54.5	54.3	0.2	0.4%
<i>granite</i>	54.3	53.2	1.1	2.0%
<i>rock salt</i>	34.3	1.3	31.7	92.4%

© Prentice-Hall, Inc.

## THE DAILY GRIND *(continued)*

### ◆ Analyze and Conclude

1. Graph the results from Part A. Place time on the horizontal axis and mass on the vertical axis. How did the mass of the limestone chips change over time?

*The graph should show that the mass of the chips decreased after each period of weathering, but the amount of decrease became less each time they were weathered.*

2. In Part A, how did the appearance of the limestone chips change over time?

*At first, the limestone chips had irregular shapes, and many of their points were sharp. At the end, the chips were smoother, and they had fewer sharp points.*

3. In Parts A and B, what happened to the rock that was “lost” to mechanical weathering? In your model, where did that lost rock go?

*The process of abrasion broke off small sections of rock, changing them into particles of sediment. That sediment was poured off with the water into the discard jar.*

### ◆ Critical Thinking and Applications

1. Based on your results from Part A, what can you conclude about the mechanical weathering of rocks carried along by the water in rivers and streams?

*In the beginning, the rocks are relatively large and have irregular shapes. As mechanical weathering occurs, the rocks become smaller and smoother. The rate of weathering decreases after the initially irregular rocks become smoother.*

2. Based on your results from Part B, what can you conclude about the mechanical weathering of rocks carried by moving water? How might those results be explained?

*Different rocks weather at different rates. The differences in weathering might be caused by the hardness of the rocks, the initial shapes, and how rapidly the rock dissolves in water.*

### ◆ More to Explore

How does the amount of rock “lost” during abrasion by water compare with the amount of sediment produced? Use ideas from the lab just completed to design an experiment to investigate that question. Your teacher must approve your procedure before you begin. Remember to wear your safety goggles and lab apron while carrying out your procedure.

*In one method, students could use filter paper to find the mass of rock in the discard bottle and compare it to the amount of rock “lost” by the rock chips; they must wet the filter paper before finding its mass. In another method, they could pour a given amount of the discard water into an evaporating dish and find the mass of the material remaining when the water evaporates.*

**LAB 9****LABORATORY INVESTIGATION**

# Constructing a Foucault Pendulum

**Key Concepts:** One of Earth's motions is rotation. Observing the apparent movement of a pendulum can show Earth's rotation.

**Skills Focus:** Observing, inferring, predicting, making models

**Time Required:** 40 minutes

## ◆ Pre-Lab Discussion

In 1851, Jean Foucault was the first to prove that Earth rotates. He hung a heavy iron ball from a wire 67 meters long. He set this pendulum swinging north and south. He knew that a free-swinging pendulum does not change direction. After about 8 hours, however, the pendulum was swinging east and west. Foucault concluded that Earth had rotated beneath the swinging pendulum.

In this investigation, you will make a device that uses the principle behind a Foucault pendulum.

1. Compare and contrast rotation and revolution.

**Rotation and revolution are both motions of Earth. Rotation is spinning on an axis, and revolution is one object moving around another object.**

2. Which movement, rotation or revolution, causes day and night? Explain.

**rotation, because day and night are caused by Earth's spinning on its axis**

## ◆ Problem

How can you demonstrate that Earth rotates?

### ◆ Materials *(per group)*

2 ring stands  
2 burette clamps  
wooden dowel, about 40 cm long  
board, at least 45 cm long  
thread, about 30 cm  
scissors  
fishing sinker or several metal washers  
or nuts, 110 g or more  
sheet of lined paper  
tape  
meter stick

**Alternative Materials:** Instead of a board, any sturdy, flat object, such as a cookie sheet, can be used. If student desks are movable, have students omit the board and rotate the entire desk.

**Teaching Tips:** Be sure there is enough room for students to move around the setup.

**Encourage students to move the setup in one fluid, steady motion, so they don't disturb the pendulum's motion. If the motion is disturbed, students must start over.**

**Students may need a review of relative motion. Ask them to give other examples, such as how scenery appears to move when someone is in a moving car, even though it is the car and passengers that are moving.**

- ◆ **Safety**   Review the safety guidelines in the front of your lab book.

Use caution in handling sharp scissors.



## CONSTRUCTING A FOUCAULT PENDULUM *(continued)*

### ◆ Procedure

1. Tape a sheet of lined paper on the middle of the board. The lines should be perpendicular (at  $90^\circ$ ) to the length of the board. Then set up the ring stands, clamps, and dowel as pictured in Figure 1.

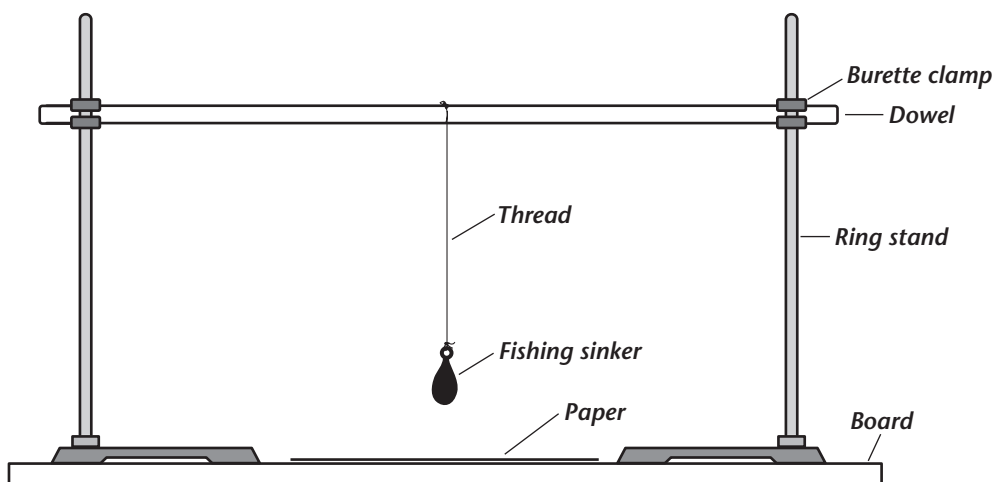

Figure 1

2. Cut a piece of thread about 30 cm long. Tie the fishing sinker to one end of the thread. Tie the other end of the thread to the center of the dowel so that the sinker can swing freely like a pendulum.
3. Carefully set the pendulum swinging in the direction of the lines on the paper. Draw a two-headed arrow on the paper to show the direction the pendulum is swinging. Label the arrow A.
4. Using two students, slowly turn the whole apparatus clockwise one quarter of a full turn ( $90^\circ$ ). Be careful not to disturb the swinging of the pendulum.
5. Draw a two-headed arrow on the paper to show the direction the pendulum is now swinging. Label this arrow B. Observe how the direction of the pendulum has changed in relation to the lines on the sheet of paper.
6. Predict how the pendulum swing will compare to the arrows when the students at the ends of the board again slowly turn the whole apparatus clockwise another quarter of a turn ( $90^\circ$ ). Give a reason for your prediction.

**Students will likely predict that the swing will again match the direction of arrow A, given that arrow B was perpendicular to arrow A.**

7. Turn the apparatus clockwise  $90^\circ$  and compare the results to your prediction.

## CONSTRUCTING A FOUCAULT PENDULUM *(continued)*

### ◆ Observations

1. Describe how the direction of arrow A differs from that of arrow B.

**Arrow A is perpendicular to arrow B.**

---

---

2. Describe how the direction of the pendulum changed in relation to the lines on the sheet of paper.

**The pendulum changed direction 90° in relation to the lines on the sheet of paper.**

---

---

### ◆ Analyze and Conclude

1. If a pendulum was swinging freely on Earth, how would it appear to act if Earth rotated?

**The pendulum would appear to slowly change direction opposite to the direction of Earth's rotation.**

---

---

2. How would the pendulum appear to act if Earth did not rotate?

**The direction of the pendulum would appear to stay the same.**

---

---

3. Think about a playground swing and how it swings with the seat empty and with someone on the seat. Why do you think it is important to use a fairly heavy weight on your pendulum?

**More weight keeps the pendulum swinging longer and in a more consistent direction.**

---

---

### ◆ Critical Thinking and Applications

1. Describe the changes in geographical direction that a pendulum would appear to undergo if it began swinging north and south.

**The pendulum would slowly turn until it appeared to swing east-west. Then it would be back to north-south. Then it would gradually return to east-west. Eventually, it would be back to north-south.**

---

---

---

## CONSTRUCTING A FOUCAULT PENDULUM *(continued)*

2. What happens to the swing of a pendulum, or its arc, as the pendulum swings over a period of time?

**The swing, or arc, gets smaller and smaller. Eventually the pendulum stops swinging.**

---

3. What is the reason for this change? (Hint: Think about what the pendulum weight and string move against.)

**Air resistance and friction of the thread on the dowel slow the pendulum, eventually stopping it.**

---

### ◆ More to Explore

Construct a simple working model of a Foucault pendulum. Can this model be used to show Earth's actual rotation? Write a procedure you would follow to answer this question. Have the teacher approve your procedure before you carry out the investigation. Wear your goggles while carrying out your procedure.

See the following figure for a sample setup. Suggest where students could find a flat surface at the necessary height. Students can set up blocks around the pendulum to see the actual effects of Earth's rotation. A surface clamped on top of a 10-foot stepladder works. As Earth rotates, the orientation of the arc of the pendulum will change. This model can be used to observe Earth's actual rotation because the cord is long enough and the weight has enough mass to make air resistance less important than it is with the smaller pendulum.

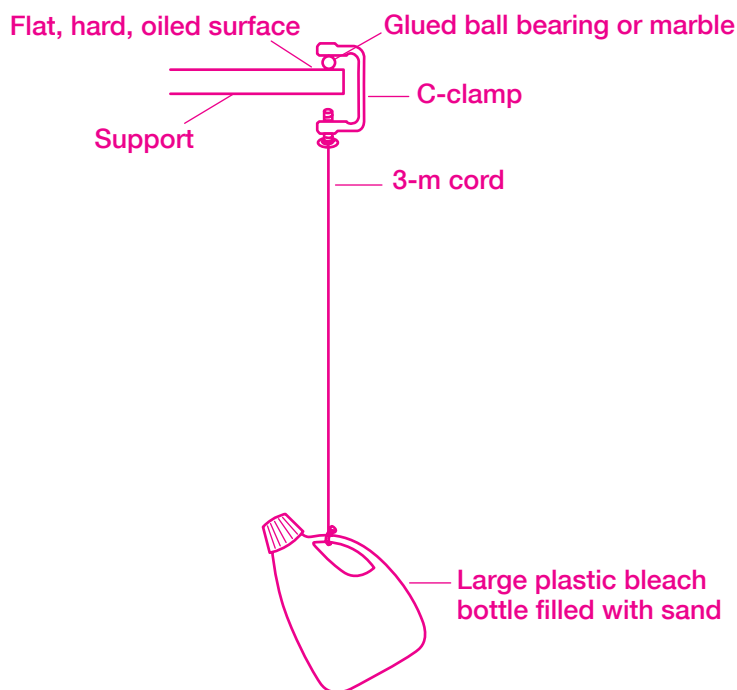

**LAB 10** **LABORATORY INVESTIGATION**

# Examining Bones, Muscles, and Skin

**Key Concepts:** Each part of the human body has specific functions. The structure of the part is often related to its functions.

**Skills Focus:** Observing, inferring, communicating, controlling variables

**Time Required:** 40 minutes; Parts A and B are not dependent on each other. If time is a factor, the parts can be done separately, with appropriate questions chosen for each part. More to Explore should be done with Part B.

## ◆ Pre-Lab Discussion

Have you ever seen a picture of a jellyfish? The body of the animal has no rigid shape because it has no bones. Think of what your body would be like without bones. Bones provide the structure needed for you to stand upright and to hold this paper. Bones work closely with muscles to allow your body to move. Muscles also keep important parts of your body, such as your heart, working. In Part A of the following investigation, you will examine bone and muscle cells to see how their structure relates to what they do.

Of course, you can't see your bones and muscles. They are covered by the largest organ in your body—your skin. What does skin do? One of its many purposes is to protect the inside of your body against injury and disease. It also contains sense receptors that give you your sense of touch. In Part B of this investigation, you will examine one important function of the sense of touch—the ability to distinguish different temperatures.

1. What are the three types of muscles? Explain how they differ.

**Skeletal muscles are striated muscles that are voluntary and move bones. Smooth muscles are not striated and are involuntary. Cardiac muscles are in the heart, are striated, and involuntary.**

2. Name three functions of bones and three functions of skin.

**Bones protect internal organs, produce blood cells, and store certain minerals until the body needs them. Skin regulates body temperature, eliminates wastes, and produces Vitamin D.**

## ◆ Problem

How are the three types of muscle cells and bone cells alike, and how do they differ? How does your body sense differences in temperature?

**Alternative Materials:** Any identical containers can be used for Part B and More to Explore.

## ◆ Materials *(per group)*

- |                                     |                                   |
|-------------------------------------|-----------------------------------|
| prepared slides of smooth muscle    | 3 transparent plastic cups        |
| skeletal muscle                     | cold water                        |
| cardiac muscle                      | room-temperature water            |
| cross-section of compact human bone | paper towel                       |
| microscope                          | clock or watch with a second hand |

**EXAMINING BONES, MUSCLES, AND SKIN** *(continued)*

◆ **Safety**  Review the safety guidelines in the front of your lab book.

Use caution when handling the microscope slides. If they break, tell the teacher.

Do not pick up broken glass.

**Advance Preparation:** Review with students the proper use and care of a microscope. Set out large containers of water several hours before class so that they can reach a consistent room temperature. If materials are limited, you may want to set up stations, one each for Part A, Part B (cold

◆ **Procedure**

**Part A: Observing Bone and Muscle**

1. Using the microscope, first on low power and then on high power, examine a prepared slide of skeletal muscle. Look for nuclei in the cells.
2. In Part A of Observations, sketch the skeletal muscle tissue that you see. Note the magnification you use to view it. Label details of the cells such as striations (stripes) and nuclei.
3. Using the microscope, first on low power and then on high power, examine a prepared slide of cardiac muscle. Look for nuclei in the cells.
4. In Observations, sketch the cardiac muscle tissue that you see. Note the magnification you use to view it. Label details of the cells.
5. Using the microscope, first on low power and then on high power, examine a prepared slide of smooth muscle. Look for nuclei in the cells.
6. In Observations, sketch the smooth muscle tissue that you see. Note the magnification you use to view it. Label details of the cells.
7. Using the microscope, first on low power and then on high power, examine a prepared slide of compact bone. Look for cells and structural features.
8. In Observations, sketch the bone tissue that you see. Note the magnification you use to view it. Label details of the structures.

water), and, perhaps, More to Explore (warm water) so that different students can be working on different parts of the investigation at the same time. Test the water before the lab starts to be sure temperatures aren't too cold or hot.

**Part B: Examining the Sense of Touch**

1. Place a cup of cold water and a cup of room-temperature water on two or three paper towels in front of you. Put your index finger in the cold water for about 5 seconds.
2. Remove your finger from the cold water, and put it in the room-temperature water. Immediately tell your partner how the water feels. For this step and each of the following steps, have your partner record all your observations in the Data Table.
3. Leave your finger in the room-temperature water. Describe how the water feels after a few minutes.
4. While one finger is still in the water, put your index finger from your other hand in the same cup.
5. Remove both fingers from the water. Put your original finger into the cold water and leave it there for about 20 seconds. Then move it into the room-temperature water. Leave your finger in the cup for a few minutes.

**EXAMINING BONES, MUSCLES, AND SKIN** *(continued)*

6. Put your other index finger into the room-temperature water. Compare how the water feels now to how it felt in Step 3.
7. Remove both fingers from the water.

**◆ Observations**

**Part A**

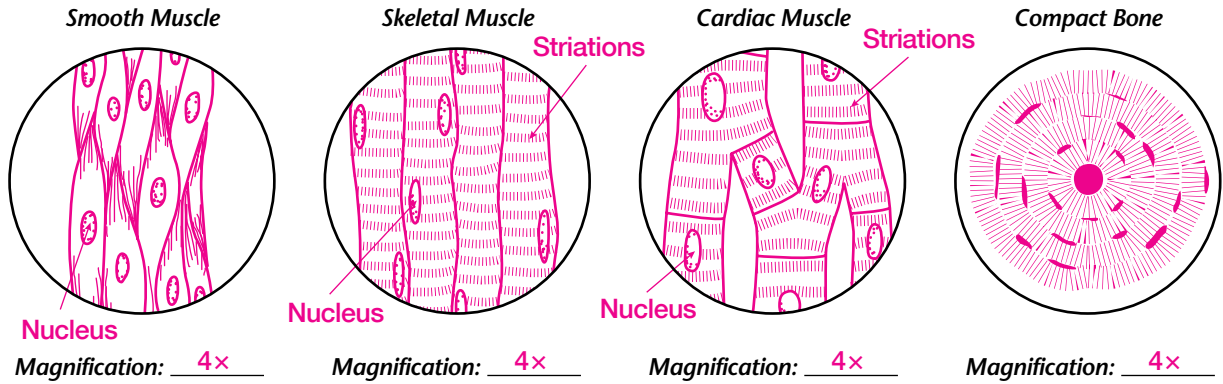

**Part B**

**Data Table**

**Sample Data**

Step	What to Observe	Observations
2	How did the water feel when you first put your finger in the room-temperature water?	It felt as if it were warm water.
3	How did the water feel when you left your finger in the room-temperature water?	The water felt less warm as time passed.
4	How did the water feel to your other finger when you put it in the room-temperature water?	The water felt cooler to this finger than to the other finger.
5	How did the water feel when you first put your finger in the room-temperature water this second time?	It felt as if it were warm water.
6	How did the water feel when you left your finger in the room-temperature water this second time?	It took longer for the water to feel room-temperature rather than warm.
7	How does the water feel now compared to how it felt in Step 5?	There was a greater difference in perceived temperature than in Step 5.

**◆ Analyze and Conclude**

1. What structure can you clearly see in the muscle cells that you cannot see in the bone? Describe this structure.

*Students should see nuclei—rounded or elliptical structures generally in the middle of the cells.*

*Answers might also note that the bone slide is a cross-section.*

## EXAMINING BONES, MUSCLES, AND SKIN *(continued)*

2. What is the main structural difference between cardiac and skeletal muscle?

The cardiac fibers have side branches. Because the fibers are more strongly held together, the muscles are stronger and exhibit less fatigue.

3. Did the sensors in your fingers respond in the same manner to the room-temperature water? Explain your answer.

The fingers' sensors did not respond in the same manner to the room-temperature water. The sensors appeared to respond more to changes in temperature rather than to the actual temperature of the water.

### ◆ Critical Thinking and Applications

1. Can you infer that striations, or stripes, have anything to do with whether a muscle is voluntary or involuntary? Explain.

No, there is no relationship between striations and whether a muscle is voluntary or involuntary. For example, both cardiac and skeletal muscles are striated, but skeletal muscle is controlled by your will and cardiac muscle is not.

2. You looked at a cross-section of a bone. Describe how you could model the interior structure of an entire bone.

Answers may vary but should indicate that the bone in the cross-section could be modeled with concentric tubes.

3. Suppose one person has been outdoors on a hot day and another person has been in an air-conditioned room. They both go into a room of average temperature. Use your results from Part B to explain the temperature sensed by both people in the room of average temperature.

The person who had been outside would sense the room as cool, and the person who had been in the air-conditioned room would sense the room as warm.

### ◆ More to Explore

Repeat Part B of this experiment, using warm water in place of cold water.

**CAUTION:** Do not use water that is hot enough to burn you or cause discomfort.

Record all of your observations in a table similar to the one used in Part B.

**After placing their fingers in the warm water for 5 seconds, students' observations should be the opposite of those in the Data Table for Part B; that is, for steps in which the water felt warmer in Part B, the water should feel cooler in More to Explore. Where the water felt cooler, it should now feel warmer.**

**LAB 11****LABORATORY INVESTIGATION**

# Nutrient Identification

**Key Concepts:** Nutrients in food can be identified using simple tests.

**Skills Focus:** Observing, predicting, classifying, posing questions

**Time Required:** 40 minutes

## ◆ Pre-Lab Discussion

Do you know what foods have a lot of protein? Plenty of carbohydrates? Carbohydrates, fats, proteins, vitamins, minerals, and water are all nutrients in your food. You can detect the presence of some of these nutrients by taste. For example, all foods that taste sweet contain some form of sugar unless they are artificially sweetened. On the other hand, some foods, such as milk and onions, contain sugar but do not taste sweet. Therefore, scientists do not rely on taste or appearance to determine what nutrients a food contains. They use other tests to identify nutrients.

In this investigation, you will perform tests to detect starches, sugars, and proteins in foods.

1. What are the two groups of carbohydrates? What are their common names?

**Simple carbohydrates are called sugars, and complex carbohydrates are called starches.**

---

2. What functions do proteins perform in your body?

**Proteins repair cells and permit cell growth in the body. They also provide energy.**

---

## ◆ Problem

**Advance Preparation:** Encourage students to bring in food samples to be tested for the presence of starches, sugars, and proteins. Mix one part honey with about five parts water before the lab.

How can you determine what nutrients are in various kinds of food?

**Alternative Materials:** Obtain indophenol if students will be doing More to Explore.

## ◆ Materials (per group)

samples of various foods, including flour, honey, and gelatin

paper towels

3 medicine droppers

iodine solution

hot plate

beaker, 400-mL

water

2 test tubes

Benedict's solution

test-tube holder

Biuret solution

**Teaching Tips:** Anyone who gets Benedict's or Biuret solution on himself or herself should flush the area with plenty of water. Clothes that receive a spill should be washed before being worn again. Be sure students wear aprons and goggles.

**Make class data tables on the board or on an overhead to record the test results.**

**Remind students not to shake test tubes too vigorously and never to point a test tube at anyone.**

**Holding the test tubes up against a piece of white paper may make the color changes easier to see. The different colors for Benedict's solution correspond to different concentrations of sugar: green shows a low concentration, orange or red a high concentration, and yellow a moderate concentration.**



## NUTRIENT IDENTIFICATION *(continued)*

◆ **Safety**  Review the safety guidelines in the front of your lab book.

Iodine solution and Biuret solution can stain skin and clothing. Benedict's solution can burn skin. If you spill any of these solutions on your skin, rinse it off immediately with cold running water and tell the teacher. Use a test-tube holder when handling hot test tubes.

### ◆ Procedure

If foods are semiliquid, have students add water to make the foods more liquid before testing them.

#### Part A: Test for Starches

1. Place a small amount of flour on a paper towel.
2. Use a medicine dropper to put 1 or 2 drops of iodine solution on the flour.  
**CAUTION:** Keep iodine solution off your skin because it will leave a stain.
3. Notice that the iodine solution turns purplish blue or blue-black. This color change indicates that flour contains starch. If the iodine remains yellow-brown, starch is not present.
4. Choose two to five other foods to test. Predict whether each food contains starch. Give a reason for your prediction.

Predictions will depend on foods chosen. Predictions may be based on experiences where foods have been described as starchy.

5. Test these additional foods for the presence of starch and record your results in Data Table 1.

#### Part B: Test for Sugars

1. Set up a hot-water bath by placing a beaker half full of water on a hot plate and starting to heat the water.
2. Use a medicine dropper to put 30 drops of honey-and-water solution in a test tube.
3. Use another medicine dropper to add Benedict's solution until the test tube is about one-third full.

**CAUTION:** Keep Benedict's solution away from your skin because it can burn you. If you spill some on you, rinse it off immediately with cold running water and inform the teacher.

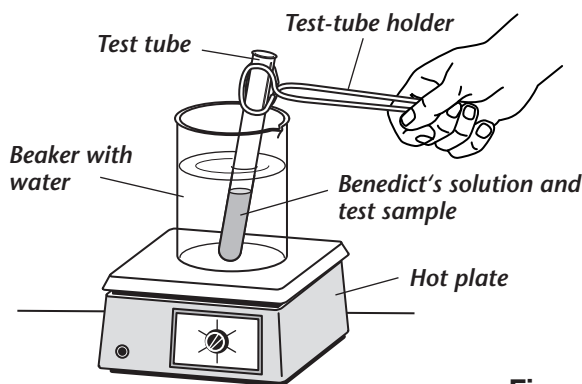

Figure 1

### **NUTRIENT IDENTIFICATION** *(continued)*

4. Wait until the water in the water bath is boiling. **CAUTION:** *Be careful when using the water bath. Adjust the heat so that the water does not boil too vigorously. Take care not to point the opening of the test tube toward anyone. Remember to wear your safety goggles.* Use a test-tube holder to hold the test tube upright in the water bath. See Figure 1. Gently boil the mixture for 2 to 5 minutes.
5. Remove the test tube from the water bath. The solution should have turned green, yellow, orange, or orange-red. Any of these colors indicates that sugar is present. If the Benedict's solution remains blue, sugar is not present. Note: Benedict's solution indicates the presence of simple sugars such as glucose and fructose, which are found in most fruits. It does not detect the presence of complex sugars such as lactose (milk sugar).
6. Choose two to five additional foods to test. If you use solid foods, crush the material to be tested, put it in a test tube, and add 30 drops of water. If you use liquids, test 30 drops.
7. Predict whether each of these foods contains sugar. Give a reason for your prediction.

**Predictions will depend on foods chosen. Predictions may be based on experiences where foods have been called sweet.**

---

8. Test these additional foods for sugar and record your results in Data Table 2.

#### **Test C: Test for Proteins**

1. Use a medicine dropper to fill a test tube about one-third full of gelatin solution.
2. Add 10 drops of Biuret solution. **CAUTION:** *Biuret solution will burn skin and clothing. If you spill any solution on yourself, rinse it off immediately with cold running water and inform your teacher.*
3. Hold the tube against a white background. Notice that the mixture has turned violet. This color change indicates the presence of protein. If there is no color change, protein is not present.
4. Choose two to five other foods to test. Predict whether each contains protein. Give a reason for your prediction.

**Predictions will depend on foods chosen. Predictions may be based on personal experience with reading food labels.**

---

5. Test these additional foods for protein and record your results in Data Table 3.

## NUTRIENT IDENTIFICATION *(continued)*

### ◆ Observations

Data Table 1

Sample Data

<i>Food Tested</i>	<i>Color with Iodine Solution</i>	<i>Is Starch Present?</i>
Flour	Purplish-black or blue-black	Yes
Diet clear soda	Yellow-brown	No
Regular clear soda	Yellow-brown	No
Milk	Yellow-brown	No
Apple	Yellow-brown	No
Bread	Purplish-black or blue-black	Yes

Data Table 2

<i>Food Tested</i>	<i>Color with Benedict's Solution</i>	<i>Is Simple Sugar Present?</i>
Honey and water	Green, yellow, orange, or orange-red	Yes
Diet clear soda	Blue	No
Regular clear soda	Green, yellow, orange, or orange-red	Yes
Milk	Blue	No
Apple	Green, yellow, orange, or orange-red	Yes
Bread	Green, yellow, orange, or orange-red	Yes

Data Table 3

<i>Food Tested</i>	<i>Color with Biuret Solution</i>	<i>Is Protein Present?</i>
Gelatin solution	Violet	Yes
Diet clear soda	No color change	No
Regular clear soda	No color change	No
Milk	Violet	Yes
Apple	No color change	No
Bread	Violet	Yes

## NUTRIENT IDENTIFICATION *(continued)*

### ◆ Analyze and Conclude

1. Of the foods you tested, which contain starch? How do you know? Were your predictions correct?

Answers will vary. For the sample data, flour and bread contain starches. Food containing starch turns iodine blue-black.

2. Of the foods you tested, which contain sugar? How do you know? Were your predictions correct?

Answers will vary. For the sample data, honey, regular soda, apples, and bread contain simple sugars. Foods containing simple sugars will turn Benedict's solution green, yellow, orange, or orange-red.

3. Of the foods you tested, which contain protein? How do you know? Were your predictions correct?

Answers will vary. For the sample data, gelatin, milk, and bread contain protein. Foods containing protein will turn Biuret solution violet.

### ◆ Critical Thinking and Applications

1. If a food does not turn Biuret solution violet, do you know what nutrients the food contains? Give a reason for your answer.

No, Biuret solution is used to test for proteins only. It does not indicate whether fats, starches, or sugars are present. The tests for these nutrients must be done individually.

2. Why is it important to include starches, sugars, and proteins in your diet?

By eating foods from the different food groups, you will maintain a balanced diet and get the nutrients necessary for good health.

3. Write at least two new questions about other nutrients (such as minerals, vitamins, and so forth) that might be in the foods you tested.

Answers will vary. Sample questions: Does a food contain saturated or unsaturated fats? Are there tests to detect certain vitamins and minerals?

**NUTRIENT IDENTIFICATION** *(continued)*

4. Briefly, how would you go about answering your questions above? (**CAUTION:** *Do not perform any experiment unless the teacher approves your written plan.*)

**Answers will vary. Sample answer: Find out what chemicals test for saturated fats, unsaturated fats, certain vitamins, and minerals.**

---

---

---

**◆ More to Explore**

Chemical tests can detect different vitamins in foods. Indophenol is a chemical that tests for vitamin C. To conduct this test, wear safety goggles and a lab apron. Pour indophenol into a test tube to a depth of 2 cm. Add the substance to be tested, one drop at a time. Keep track of the number of drops added and shake the test tube after each drop is added. Continue until the blue color disappears. The more drops of test substance required to eliminate the blue color, the less vitamin C the substance contains. Compare the vitamin C content of various fruit juices, such as orange, apple, grapefruit, or lemon, or various brands of one kind of juice.

**Amounts will vary. The content of vitamin C is influenced by the following factors: whether vitamin C has been added; whether water has been added; and whether the juice is fresh, frozen, or canned.**

**LAB 12** **LABORATORY INVESTIGATION**

# Direction of Blood Flow

**Key Concepts:** Veins have valves that keep blood flowing in one direction.

**Skills Focus:** Observing, inferring, communicating

**Time Required:** 40 minutes

## ◆ Pre-Lab Discussion

If you're healthy, you probably don't think much about your circulatory system. It just pumps along, keeping you alive. But think about this: liquids flow downhill. How can blood travel up to your heart, against the flow of gravity, as well as down? Somehow the muscle that is your heart and the arteries, veins, and capillaries work together to keep blood flowing to every part of your body.

In this investigation, you will demonstrate a feature of your veins that helps keep blood flowing throughout your body.

1. Compare and contrast the structures of arteries and veins.

*Artery walls have three layers and are muscular and thick. Walls of veins also have three layers, but they are thinner and less muscular than artery walls. Large veins contain valves, which arteries don't have. A valve is a flap of tissue that prevents blood from flowing backward.*

2. Why is it essential that blood flow upward in the body?

*Answers may vary. Sample answer: If blood couldn't flow uphill, it would go to your feet and stay there and couldn't flow up to your brain.*

## ◆ Problem

What prevents blood from flowing backward toward the lower part of the body?

## ◆ Materials *(per group)*

none

**Teaching Tips:** Be sensitive to students who may have physical difficulty with this activity. Some students, such as overweight students, might have trouble observing their veins or exercising (in More to Explore). These students can still be observers or recorders.

## ◆ Safety Review the safety guidelines in the front of your lab book.

Be gentle when exerting pressure on veins.

**Students should press gently on their veins. Demonstrate the procedure if students have trouble following the directions.**

**Step 6 may show no change in the vein, or the valves may let a little blood drop back.**

**DIRECTION OF BLOOD FLOW** *(continued)*

◆ **Procedure**

1. Work with two partners. Decide which partner will observe, which one will be the subject, and which one will record observations.
2. Have the subject stand with both arms down at his or her sides until the veins on the back of the hands stand out.
3. The subject should keep both arms down. The observer should put one finger from each hand next to each other on one of the subject's raised veins. See Figure 1.
4. The observer leaves the finger closest to the ground where it is. He or she slides the other finger upward along the vein for about 4 cm, pressing firmly but gently.
5. The observer tells the recorder what happens to the vein. The recorder writes the observations in the Data Table.
6. The observer keeps the finger closest to the ground in place, then releases the upper finger. The observer tells the recorder what happens to the vein, and the recorder writes the observations in the Data Table.
7. The observer releases the finger that is still in place and tells the recorder what happens to the vein. The recorder writes the observations in the Data Table.
8. Everyone switches roles and repeats steps 2–7.

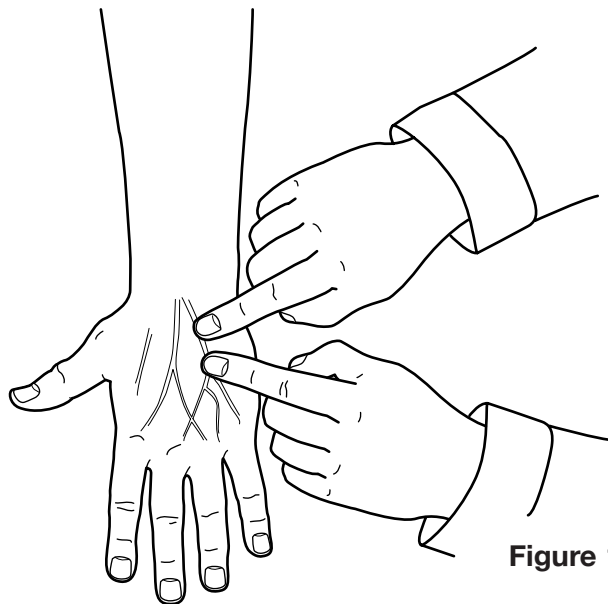

**Figure 1**

◆ **Observations**

**Data Table**

<b>Step</b>	<b>Effect on Vein</b>	
	<b>Subject 1</b>	<b>Subject 2</b>
<i>Observer moves fingers apart.</i>	<b>The vein seems to disappear.</b>	<b>The vein seems to disappear.</b>
<i>Observer releases upper finger.</i>	<b>The vein stays flat.</b>	<b>Blood comes a little way back into the vein.</b>
<i>Observer releases both fingers.</i>	<b>The vein fills up.</b>	<b>The vein fills up.</b>

© Prentice-Hall, Inc.

## DIRECTION OF BLOOD FLOW *(continued)*

### ◆ Analyze and Conclude

1. How do veins and valves contribute to the effect you saw when the observer's fingers moved apart?

The blood was pushed out of the vein by the top finger, and the bottom finger prevented any more blood from coming into the vein.

2. How do veins and valves contribute to the effect you saw when the observer released the upper finger?

A valve prevented blood from coming back into the vein.

3. How do veins and valves contribute to the effect you saw when the observer released both fingers?

The vein filled up after the pressure was removed. Valves enabled the blood to flow in the proper direction.

4. Use your observations to summarize why blood doesn't flow backward in your body.

Valves in the veins allow blood to pass in one direction but not in the other direction. Thus, blood cannot flow backward in the body.

### ◆ Critical Thinking and Applications

1. What would have happened if you had used an artery instead of a vein in this experiment?

Arteries do not contain valves. If an artery had been used, blood would have filled the artery when the observer released the finger between the heart and the lower finger in Step 6.

2. In terms of circulation, why is it important to wear clothes that are not too tight? Include evidence from the lab in your answer.

Clothes that are too tight might prevent proper blood flow. If clothing presses on veins, it might have the same effect as the fingers in the investigation did on blood flow.



**DIRECTION OF BLOOD FLOW** *(continued)*

3. Many buildings have plumbing in rooms that are below ground level, so the plumbing is lower than the building’s drain pipe. Use what you learned in the investigation to explain how someone could design a bathtub drain in such a room. The drain water must not flow back into the bathtub.

*The drain pipe would need to contain a valve that would allow the drain water to go out but not come back in the other direction.*

**◆ More to Explore**

**New Problem** When you exercise for cardiorespiratory fitness, you want your heart to beat at a target heart rate. What kind of exercise takes you closer to your target heart rate in 1 minute?

**Possible Materials** Use a stopwatch or other timer with a second hand.

**Safety** Do not exercise if you have health conditions, such as asthma, that might make exercise harmful.

**Procedure** Take your pulse while resting, and calculate the low end of the range of your target heart rate. See page 412 in your textbook.

Develop a procedure to determine whether 1 minute of jumping rope or 1 minute of running in place gets you closer to your target heart rate. On a separate sheet of paper, list the steps of your procedure. Have the teacher approve your procedure before you carry out the investigation.

**Observations** On a separate sheet of paper, create a data table to record the resting heart rate, calculated target heart rate, and actual heart rate for both types of exercise.

**Analyze and Conclude**

1. Why do different exercises affect how long it takes you to reach your target heart rate?

*Jumping rope uses arm muscles as well as leg muscles, so the whole body works and the heart has to pump harder to supply blood to more muscle tissue.*

2. Why do you think it is important for the heart rate to stay in the target range?

*Answers will vary. Sample answer: The target rate exercises the heart without exhausting or damaging heart muscle.*

*Procedures should have the subject take a resting pulse, exercise for 1 minute, and take a pulse immediately. The subject needs to rest until the pulse is normal resting pulse again; then the subject does the second exercise. Sample calculation: resting heart rate = 77 beats/min; maximum heart rate =  $210 - 77 = 133$  beats/min; lower limit of target rate =  $(133 \times 0.6) + 77 = 157$  beats/min.*

**LAB 13**

**LABORATORY INVESTIGATION**

# Measuring the Volume of Exhaled Air

**Key Concept:** During breathing, differences in air pressure inside and outside the human body force air into and out of the lungs. The volume of air involved in this process can be measured.

**Skills Focus:** Observing, inferring, making models, measuring, calculating, designing experiments, controlling variables

**Time Required:** 40 minutes

## ◆ Pre-Lab Discussion

If you have healthy lungs, you usually are not conscious of breathing. But have you ever felt like you were “out of breath”? Maybe you had to run to answer the phone or catch the school bus. Maybe you were ill, and your lungs were congested. Whatever the reason, you felt that the volume of air your lungs could hold was not enough for the amount of air you needed.

The amount of air that lungs can hold varies from person to person. It also varies in any one person from time to time. In this investigation, you will design and use a plan to measure and compare the volume of air you exhale when you exercise and the volume of air you exhale when you are not exercising.

1. How does the respiratory system work?

**Air is taken into the lungs. Oxygen from the air is exchanged with waste products, mainly carbon dioxide, which are carried in the blood. These wastes are then removed from the body as the person exhales air from the lungs.**

2. Explain the difference between *breathing* and *respiration*.

**Breathing involves the movement of air into and out of the lungs. Respiration involves processes that occur in cells.**

## ◆ Problem

How can you measure the volume of exhaled air?

## ◆ Possible Materials (per group)

- 2-hole rubber stopper
- 2-L plastic bottle
- glass tubing, long and short
- rubber or flexible plastic tubing, 2 pieces
- 100-mL graduated cylinder
- paper towels
- cloth towel
- glycerin
- timer

## Teaching Tips:

**[Step 2]** Either insert the glass tubing into the rubber stopper for the students or demonstrate how to safely do this procedure. Tubing may break and cause cuts. Wrap tubing securely in a cloth towel, covering the area you will hold. Use a lubricant, such as glycerin, on the tubing before carefully inserting it with a twisting motion into the stopper.

**[Step 2]** A few drops of food coloring in the water may make measurement easier.

**[Step 2]** In constructing the spirometer, be sure the glass tube through which the exhaled air enters is above the surface of the water and that the other glass tube is well below the surface of the water but does not touch the bottom of the bottle. Thus, the exhaled air increases the air pressure above the liquid. To equalize atmospheric pressure and the pressure in the bottle, a volume of liquid equal to the volume of air added is pushed out of the bottle.

[Teaching Tips continued on next page]

**MEASURING THE VOLUME OF EXHALED AIR** *(continued)*

◆ **Safety**  Review the safety guidelines in the front of your lab book.

When you blow through the tubing, first place a paper towel over the end of it and blow through the towel. Do not put your mouth directly on any of the tubing. If you insert glass tubing into the rubber stopper, use extreme caution and follow the teacher's instructions. Inform the teacher of any physical reasons you should not exercise. Your teacher must approve your plan before you can perform the experiment.

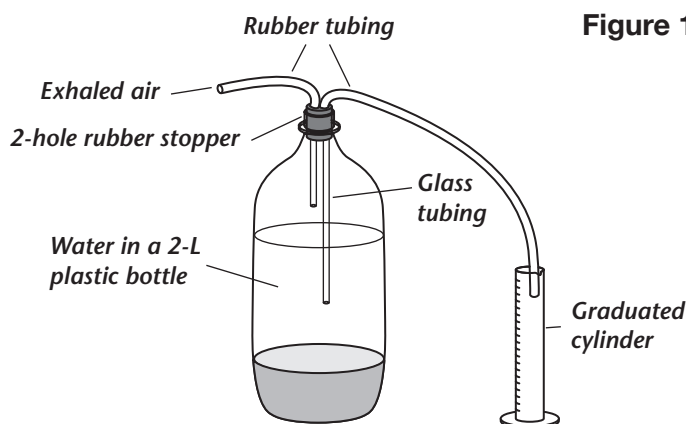
**Figure 1**

This movement of liquid increases the volume the air can occupy and thereby reduces the air pressure. Be sure it is clear to students that the volume of air they exhale equals the volume of water that comes out of the bottle. Have students return the water to the bottle after each trial.

[Step 3] If some students exhale more than 100 mL of air, use a larger container to collect the water. The collected water can then be measured using the graduated cylinder.

[Step 6] Before students run in place, be sure they have no physical conditions, such as asthma, that could cause health problems. If such conditions exist, suggest that another student in the group perform the exercise.

### ◆ Procedure

1. Read through this entire lab before you perform any part of it.
2. Use the materials listed here or other materials to assemble a spirometer—an instrument that can be used to measure the volume of air that your lungs can exhale. A spirometer is shown in Figure 1.
3. Plan how you will use your instrument to measure your lung volume. Consider what unit you will use for this measurement. On another sheet of paper, write a step-by-step plan for using your spirometer to measure the volume of your exhaled air.
4. Use Data Table 1 in Observations to record your data. You will need to record data for at least three trials; you may want to do more. You will then calculate the average volume of water displaced for all of your trials.
5. After the teacher has approved your plan, carry out your investigation. Then answer questions 1 and 2 in Observations.

**MEASURING THE VOLUME OF EXHALED AIR** *(continued)*

- After you have completed Data Table 1, run in place for two minutes.  
**CAUTION:** Do not perform this part of the activity if you have any medical condition that makes the activity unsafe. Repeat your experiment, using Data Table 2. Perform the same number of trials as before and average the trials. Then answer question 3 in Observations.
- Rest for a few minutes until your breathing returns to normal. Then repeat the experiment using Data Table 3.

**◆ Observations**

- How is the volume of water that is forced out of the bottle related to the volume of air you exhale?

*The volumes are equal.*

- In the spirometer in Figure 1, why is it important that one glass tube is above the surface of the water and one glass tube is beneath it?

*The glass tube above the surface of the water is the tubing through which the exhaled air enters the bottle. The increased air pressure in the bottle forces the water through the other glass tube. If this tube were not beneath the surface of the water, air—which could not be measured in the graduated cylinder—would be forced out the second tube.*

- How does your average volume of exhaled air when you have not been exercising compare to your average volume of exhaled air right after you exercise?

*Data should show that the average volume of air after exercising should be greater than the average volume measured when students are not exercising.*

**Data Table 1**  
(before exercising)

*Sample Data*

**Data Table 2**  
(after exercising)

**Data Table 3** (when breathing returns to normal)

<i>Trial</i>	<i>Volume of Water (mL)</i>
1	75
2	79
3	77
<i>Average</i>	77

<i>Trial</i>	<i>Volume of Water (mL)</i>
1	97
2	102
3	99
<i>Average</i>	99

<i>Trial</i>	<i>Volume of Water (mL)</i>
1	80
2	79
3	80
<i>Average</i>	80

© Prentice-Hall, Inc.

## MEASURING THE VOLUME OF EXHALED AIR *(continued)*

### ◆ Analyze and Conclude

1. Why is it important to perform several trials for each part of the investigation?

One trial might be affected by different variables even if you try to control for them. An average of several trials should provide a valid volume.

2. Choose one of your data tables. Were the volumes the same for each trial? What could you change about your plan to assure that your data are more consistent?

Volumes were likely similar but not exactly the same. Students could allow several minutes of time between each trial or make a special effort to exhale normally and not use a breath that is deeper than usual.

3. Infer why the volume of air you exhaled after exercise differed from the volume you exhaled before exercising.

Oxygen is needed for cellular respiration. Respiration proceeds at a faster rate when a person exercises, so the person needs more oxygen then. Larger breaths—larger volumes of air—provide more oxygen.

### ◆ Critical Thinking and Applications

1. What might cause differences in lung volume among students in the class?

Answers might include that students involved in activities requiring a lot of lung capacity, such as athletics or some music activities, would exhale more air. Also, larger students might have larger lung capacities.

2. Denver, Colorado, is located at a high altitude. Miami, Florida, is located at sea level. Predict how the average Data Table 1 results for students who live in Denver compare to those of students who live in Miami. Explain your reasoning.

Students will probably predict that the volumes in Denver would be larger. At a high altitude, the air is thinner. You would have to take a deeper breath to get the same amount of oxygen you can get in a smaller breath in Miami.

### ◆ More to Explore

How could you determine the total volume of air someone can exhale in one minute? Write a procedure that you would follow to answer this question. Have the teacher approve your procedure before you carry out the investigation.

Procedures may include using several spirometers. One can be used for each exhaled breath, giving other students time to measure and record the volume of the liquid forced out and to return the liquid to the bottle before that particular spirometer is used again.

**LAB 14** **LABORATORY INVESTIGATION**

# Do Mouthwashes Work?

**Key Concepts:** Antiseptic mouthwashes prevent the growth of disease-causing microorganisms.

**Skills Focus:** Observing, inferring, predicting, controlling variables

**Time Required:** 40 minutes initially; 10 minutes on each of three subsequent consecutive days for observations

## ◆ Pre-Lab Discussion

What do you use to take care of your teeth: toothbrush, toothpaste, dental floss, mouthwash? Mouthwashes are supposed to kill microorganisms that contribute to tooth decay, gum disease, and bad breath. They contain antiseptics, chemicals that kill or prevent growth of disease organisms on living tissues. How well do these mouthwashes work? Do they really kill microorganisms?

In this investigation, you will compare the effects of two mouthwashes.

1. Name four groups of organisms that cause diseases.

**bacteria, viruses, fungi, protists**

---

2. From where do disease-causing microorganisms come?

**Sources include another person, a contaminated object, an animal bite, and the environment.**

---

## ◆ Problem

How well do mouthwashes control the growth of bacteria?

## ◆ Materials *(per group)*

- 3 petri dishes with sterile nutrient agar
- pen
- masking tape
- 2 types of mouthwash
- 2 small jars
- filter paper
- scissors
- metric ruler
- forceps
- transparent tape

**Advance Preparation:** Have students bring in different brands of mouthwashes. Obtain nutrient agar plates, three for each group.

**Teaching Tips:** Caution students to handle forceps carefully.

**Cultures should be autoclaved or flooded with a strong household disinfectant solution. Use a disinfectant such as Lysol or dilute chlorine bleach. Be sure to follow state and local guidelines for disposal.**

- ## ◆ Safety
- Review the safety guidelines in the front of your lab book.*

Do not drink the mouthwashes. Have the teacher dispose of the sealed petri dishes at the end of the activity.

## DO MOUTHWASHES WORK? *(continued)*

### ◆ Procedure

- Obtain three petri dishes containing sterile agar. Do *not* open the dishes. Using a pen and pieces of masking tape, label the bottoms of the petri dishes A, B, and C. Also put your initials on each dish.
- Wash your hands thoroughly with soap, then run a fingertip across the surface of your worktable. Your partner should hold open the cover of petri dish A, while you run your fingertip gently across the agar in a zigzag motion. Close the dish immediately.
- Repeat Step 2 for dishes B and C.
- Obtain a small sample of each mouthwash in separate containers. Use a pen and masking tape to label the containers.
- Cut two 2-cm squares of filter paper. Soak a square in each mouthwash.
- Using forceps, remove one square from a container. Open the cover of dish A just long enough to put the filter paper in the center of the agar. Close the cover immediately. Record the name of the mouthwash in the Data Table.
- Repeat Step 6 for dish B, using the filter paper soaked in the second mouthwash.
- Do not add anything to dish C.
- Tape the covers of all three petri dishes so that they will remain tightly closed. Let the three dishes sit upright on your work surface for at least 5 minutes before moving them. **CAUTION:** Do not open the petri dishes again. Wash your hands with soap and water.
- As directed by the teacher, store the petri dishes in a warm, dark place where they can remain for at least three days. You will remove them only for a brief examination each day.
- Predict what you will observe over the next three days in the three petri dishes.  

Possible predictions are that the mouthwashes will be equally effective in preventing microorganism growth or that one mouthwash will be more effective. Predictions may reflect personal experience or advertising effectiveness.
- After one day, observe the contents of each dish without removing the cover. Estimate the percentage of the agar surface that shows any changes. Record your observations in the Data Table. Return the dishes to their storage place and wash your hands with soap and water.
- Repeat Step 12 after a second day and after a third day.
- After you and your partner have made your last observations, give the unopened petri dishes to the teacher.

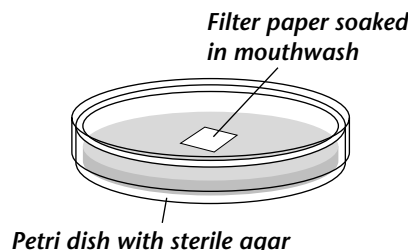

Figure 1

**DO MOUTHWASHES WORK?** *(continued)*

**◆ Observations**

Less bacterial growth should occur in dishes A and B than in C.

Bacterial growth should increase every day in the control, especially in the areas where students ran their finger across the agar.

**Data Table**

<i>Petri Dish</i>	<i>Mouthwash</i>	<i>Day 1</i>	<i>Day 2</i>	<i>Day 3</i>
<i>A</i>				
<i>B</i>				
<i>C</i>				

**◆ Analyze and Conclude**

1. How did the appearance of dish C change during three days?

*Dish C had more bacteria growing in it every day.*

2. How did the appearance of dishes A and B compare with dish C? Explain any similarities or differences.

*Dishes A and B should have less bacterial growth than dish C. The mouthwashes in dishes A and B prevented some bacterial growth.*

3. How did the appearance of dishes A and B compare with each other? How can you account for any differences?

*Answers may vary. There may be different amounts of bacteria growing in dishes A and B. Different mouthwashes may have different effectiveness.*

4. Explain why it is important to set aside one petri dish that does not contain any mouthwash.

*Dish C is a control for the experiment. Without it, students could not see how much bacteria would have grown without any mouthwash. Therefore, they could not compare the effect of the mouthwashes as completely as by using the control.*



## DO MOUTHWASHES WORK? *(continued)*

### ◆ Critical Thinking and Applications

1. Based on the results of this lab, what recommendation would you make to your family about mouthwashes?

Most students will recommend the mouthwash that prevented the most bacterial growth in its dish. Other factors in their recommendation might include price, flavor, and odor of the mouthwash.

2. What other products could you test using a procedure similar to this lab?

Answers may include antibacterial soaps and various kitchen and bathroom cleaners that claim to kill bacteria.

### ◆ More to Explore

Test one of the products in your answer to question 2 above. For example, visit a store and look at antibacterial soaps. How do their ingredients differ from other soaps? How do their prices compare to regular soap?

Antibacterial soaps contain ethyl alcohol to kill bacteria. Usually antibacterial soap costs more than regular soap.

**New Problem** How well do antibacterial soaps control the growth of bacteria?

**Possible Materials** Consider which materials you can use from the previous part of this lab. What else will you need?

**Procedure** Develop a procedure to solve the problem. Write your procedure on a separate sheet of paper. Have the teacher approve your procedure before you carry out the investigation.

**Observations** On a separate sheet of paper, make a data table like the one in the previous part of this lab in which to record your data.

#### Analyze and Conclude

What effects of antibacterial soap do your results show?

There should be less bacterial growth with the antibacterial soap than with other kinds of soap.

Experiments to test the effectiveness of these products will follow the steps of the previous part of this lab. Students could place a drop or two of liquid antibacterial soap or a mixture of antibacterial bar soap and water in the middle of the agar without using filter paper.

**LAB 15****LABORATORY INVESTIGATION**

## Locating Touch Receptors

**Key Concepts:** The sense of touch depends on receptors in the skin, the largest sense organ. The number of receptors per area of skin differs for different areas of the body.

### ◆ Pre-Lab Discussion

**Skills Focus:** Observing, inferring, communicating, measuring, controlling variables

Have you ever wondered why your hand instantly pulls back when it touches a hot pan on the stove? Have you noticed that smooth fabrics feel better to your skin than rough fabrics do? Both of these reactions involve your sense of touch.

**Time Required:**  
40 minutes

Touch receptors in your skin help you respond to your environment. Your body responds to different stimuli, including pain, temperature, and pressure. Not all parts of your body respond equally to these stimuli. Different parts of the body contain different numbers of receptors for a given amount of skin area.

In this investigation, you will test several areas of your skin and compare their sensitivity to touch.

1. How does the location of the sense of touch differ from the location of other senses?

**The sense of touch is not in one specific place. It is in skin all over the body.**

---

2. Where in the skin are the receptors that would sense a light touch?

**in the upper part of the dermis**

---

### ◆ Problem

Where are the touch receptors located on the body?

### ◆ Materials (per group)

scissors  
metric ruler  
piece of cardboard, 6 cm × 10 cm  
marker  
9 toothpicks  
blindfold

**Teaching Tips:** The exact size of the cardboard rectangle is not important. What is critical is the distance between the toothpicks.

**Supervise all students when they are touching their partner with the toothpicks. Emphasize that they must not apply pressure.**

- ### ◆ Safety
- 
- 
- Review the safety guidelines in the front of your lab book.*

Use caution in handling sharp scissors. Tie the blindfold loosely, using special care if the blindfolded student is wearing contact lenses. Students who wear eyeglasses should remove them before wearing a blindfold.

**LOCATING TOUCH RECEPTORS** (continued)

**◆ Procedure**

- Using scissors, cut the piece of cardboard into five rectangles, each measuring 6 cm × 2 cm. Label the pieces A–E.
- As shown in Figure 1, insert two toothpicks 5 mm apart into rectangle A. Insert two toothpicks 1 cm apart into rectangle B, two toothpicks 2 cm apart into rectangle C, and two toothpicks 3 cm apart into rectangle D. In the center of rectangle E, insert one toothpick.

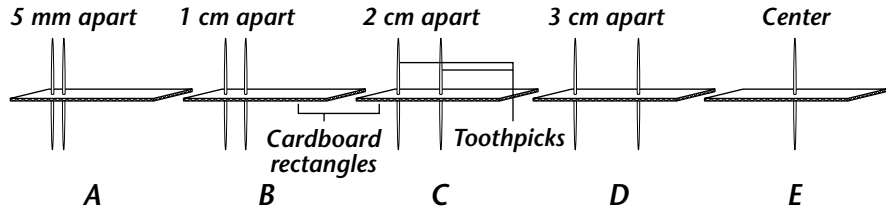

**Figure 1**

- Carefully blindfold your partner.
- Using one of the rectangles, carefully touch the palm side of your partner’s fingertip with the ends of the toothpicks.  
**CAUTION:** Only touch the toothpicks to the skin; do not press them against the skin. Ask your partner how many points he or she feels.

- In Data Table 1, record how many points your partner felt.
- Repeat steps 4 and 5, touching the palm of the hand, back of the neck, back of the hand, and inside the lower arm.
- Repeat steps 4–6 with the other cardboard rectangles. Select each rectangle randomly, not in alphabetical order.
- Reverse roles with your partner and repeat the investigation using Data Table 2.
- Answer question 1 in Observations.

**Sample Data:** Results will vary. People will feel two points with the most sensitive part of their skin and one point with the least. Most people’s sensitivity increases in this order, with the inside lower arm being least sensitive: inside lower arm, back of hand, back of neck, palm of hand, fingertip.

**◆ Observations**

**Data Table 1**

Body Part	Number of Points Felt				
	A 5 mm apart	B 1 cm apart	C 2 cm apart	D 3 cm apart	E 1 point
<b>Subject 1</b>					
Fingertip					
Palm of hand					
Back of hand					
Back of neck					
Inside lower arm					

© Prentice-Hall, Inc.

**LOCATING TOUCH RECEPTORS** *(continued)*

**Data Table 2**

<i>Body Part</i>	<i>Number of Points Felt</i>				
	<i>A 5 mm apart</i>	<i>B 1 cm apart</i>	<i>C 2 cm apart</i>	<i>D 3 cm apart</i>	<i>E 1 point</i>
<b>Subject 2</b>					
<i>Fingertip</i>					
<i>Palm of hand</i>					
<i>Back of hand</i>					
<i>Back of neck</i>					
<i>Inside lower arm</i>					

1. On which area of the skin were you best able to feel two separate points?

*Answers will vary. The most sensitive areas are usually the fingertip and palm.*

**◆ Analyze and Conclude**

1. Which area of the skin that you tested probably had the most touch receptors? The fewest? On what observations do you base this conclusion?

*Answers will vary, but most students will feel the most sensation in the fingertips and the least in the inside lower arm. Students can distinguish two points more often in the more sensitive areas.*

2. Rank the tested skin areas in order from the most to the least sensitive.

*Answers will vary, but most students will rank from most to least sensitive in the following order: fingertip, palm of hand, back of neck, back of hand, inside lower arm.*

3. In Step 7, why was it important to select each rectangle randomly instead of in alphabetical order?

*If you apply the rectangles in order, your partner might remember that E was the only rectangle with one point. This knowledge might bias the results.*

## LOCATING TOUCH RECEPTORS *(continued)*

4. Did you and your partner sense the same number of points in each test? If not, why do you think your results were different?

Answers will vary. Sample answer: No, some people have thinner dermis, which allows more sensitive touch reception.

### ◆ Critical Thinking and Applications

1. Think about the test area that had the most touch receptors. How does having a lot of receptors in this area benefit you?

Fingertips are a primary means of touching to explore properties such as texture and temperature. For safety, fingertips must quickly sense temperature to avoid burns or sense pain to avoid injury.

2. Explain how a lack of touch receptors in the bottom of your feet would affect your ability to walk.

Walking depends on being able to feel when your feet are touching the ground. If you lacked touch receptors in your feet, you might think your feet were on the ground when they weren't. Also you might walk on hot or sharp objects unknowingly and harm yourself.

3. Why is it important to you that your body respond to pain?

Pain alerts the body to possible danger or the existence and extent of an injury.

### ◆ More to Explore

**New Problem** Can you identify similar objects by touch alone?

**Possible Materials** Consider which materials you can use from the previous part of the lab. What else will you need?

**Procedure** Develop a procedure to solve the problem. Write your procedure on a separate sheet of paper. Have the teacher approve your procedure before you carry out the investigation.

**Observations** On a separate sheet of paper, create a table to organize data for two subjects trying to identify three coins each.

**Analyze and Conclude** Do different people have different touch sensitivity? Support your answer with data from your experiment.

Answers may vary. Sample answer: Maybe. In our experiment, both subjects got the same results, but we might have had different results with a more difficult test.

A possible method is to blindfold one partner, hand him or her a coin, and ask what coin it is. The data table should track what coin was offered and what the subject thought it was.

**LAB 16** **LABORATORY INVESTIGATION**

# Model of a Negative Feedback Mechanism

**Key Concept:** The endocrine system uses negative feedback to maintain homeostasis.

**Skills Focus:** Observing, inferring, making models

**Time Required:** 40 minutes

## ◆ Pre-Lab Discussion

The endocrine system, along with the nervous system, controls your body’s daily activities. It also controls how your body develops. Endocrine glands produce chemicals called hormones, which move directly into the bloodstream. Hormones affect specific cells called target cells. These target cells are often in another part of the body. To control the amount of hormone an endocrine gland produces, the endocrine system sends chemical information back and forth in a negative feedback system. Negative feedback is an important way that the body maintains homeostasis. In this investigation, you will model how a negative feedback system works.

1. How does the pancreas act as an endocrine gland?

*The pancreas produces hormones that help control the level of glucose in the blood.*

---

2. Your blood carries hormones to every part of your body. Why doesn’t a hormone affect all your cells the same way?

*The hormone attaches to and affects only target cells that recognize its chemical structure.*

---

## ◆ Problem

**Teaching Tips:** Have students review the section on homeostasis in the textbook.

How does the pancreas use negative feedback to help maintain glucose at a certain level in the blood?

## ◆ Materials *(per group)*

- 2-liter plastic soft-drink bottle
- scissors
- rubber ball, solid, 2.5–4.0 cm in diameter
- 2 screw eyes
- string
- fishing float
- dowel, about 6 cm long
- sink or bucket
- water
- large pitcher
- marker

*The model simplifies the insulin/glucose cycle. The pancreas uses two hormones to control blood glucose levels. When levels are high, it releases insulin, which makes cells take up glucose from the blood, and the liver stores glucose as glycogen. When levels are low, the pancreas releases glucagon, which makes the liver break down glycogen and release glucose to the blood. Both of these hormones are regulated by negative feedback loops.*

**Advance Preparation:** Collect plastic bottles before the activity. Ask students to begin bringing them to class a week or two ahead of time. You may want to cut the plastic bottles before class. To save time, you may wish to construct the models yourself or have a small group of students construct them.

## MODEL OF A NEGATIVE FEEDBACK MECHANISM *(continued)*

◆ **Safety**   Review the safety guidelines in the front of your lab book.

Take care when cutting off the bottom of the soft-drink bottle. To prevent slips or falls, immediately wipe up any water spilled on the floor.

### ◆ Procedure

1. Working with a partner, carefully cut off the bottom half of the plastic bottle.
2. Insert a screw eye into a rubber ball. Cut a piece of string 20 cm long. Tie one end of the string to the screw eye and the other end to a fishing float.
3. Insert a second screw eye into the other side of the rubber ball, directly opposite the first screw eye. Cut a piece of string 10 cm long. Tie one end of the string to the screw eye and the other end to the middle of the dowel.
4. Hold the bottle upside down. Lower the float, the rubber ball, and the attached rod into the bottle. Carefully pass the rod through the neck of the bottle so that the rod hangs below the mouth, as shown in Figure 1.

Figure 1

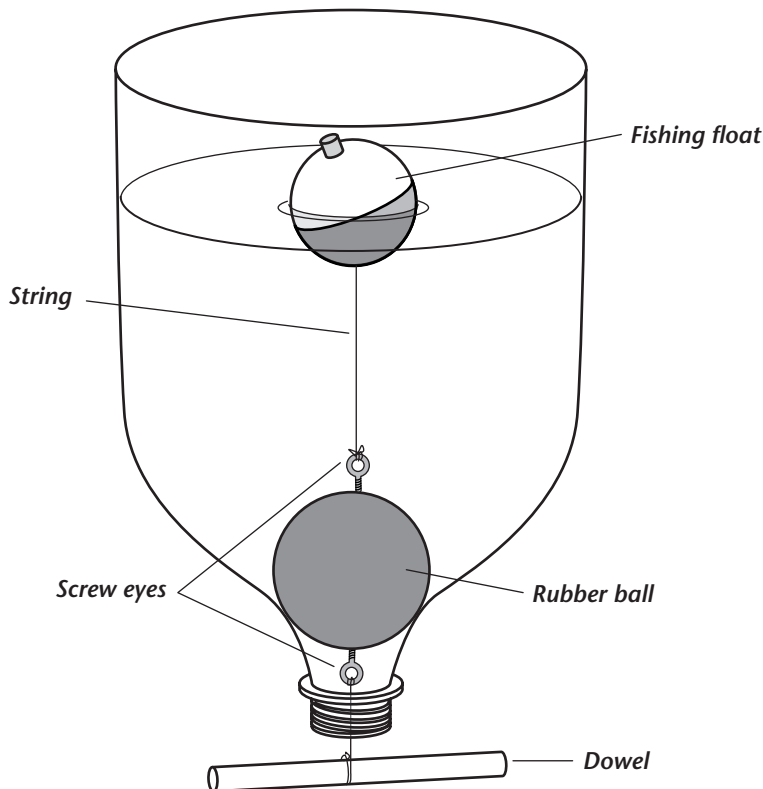

### MODEL OF A NEGATIVE FEEDBACK MECHANISM *(continued)*

5. One of you should hold the bottle over a sink or bucket, while the other slowly pours water into the bottle until the string stretches to its full length. Do not lift the ball out of the bottle opening. Mark the level of the water on the outside of the bottle.
6. Slowly add more water to the bottle and observe what happens. Answer questions 1 and 2 in Observations.
7. Add about 100 mL of water rapidly to the model. Be careful not to overfill the bottle. Observe what happens and answer question 3 in Observations.

#### ◆ Observations

1. What happens to the water level when you add more water after the string has stretched to its full length?

The level of the water goes up a little and then the water begins to drain out. This brings the water back to its original level.

2. What happens to the float and ball whenever you add water slowly?

The float moves up and pulls the string with it. The string draws the ball out of the neck of the bottle and water can escape. This makes the water drain out until it returns to its original level and the ball falls back into the neck.

3. How does the model act when you pour the water quickly, compared to when you pour it slowly?

The faster the water flows into the model, the wider the opening at the bottom of the model becomes, and the faster the water drains out of the model.



**MODEL OF A NEGATIVE FEEDBACK MECHANISM** *(continued)*

**◆ Analyze and Conclude**

Figure 2 shows the role of the pancreas in a negative feedback loop that controls the amount of glucose in the blood. The pancreas makes the hormone insulin. Insulin enables body cells to take in glucose from the bloodstream. When the glucose level in the blood is high, the pancreas releases insulin, which enables body cells to take glucose from the blood. When the glucose level in the blood drops, the pancreas stops releasing insulin. Body cells stop removing glucose from the bloodstream. When blood glucose increases, the cycle starts again.

**Figure 2**

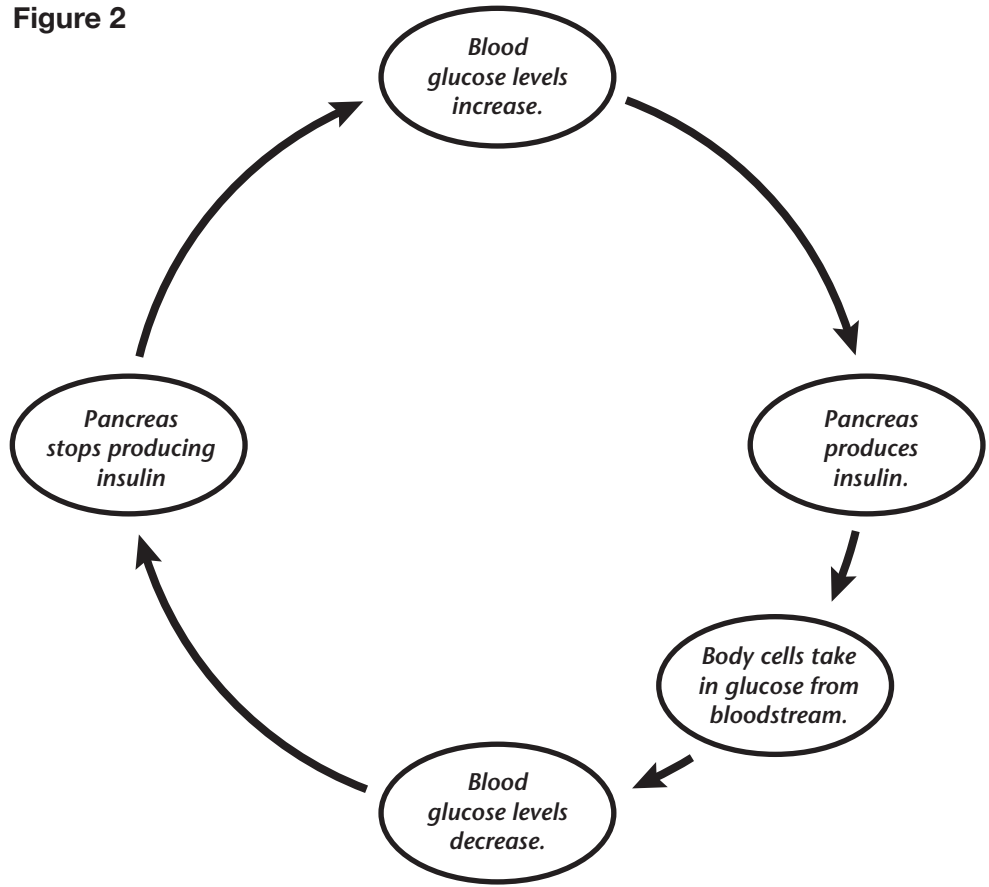

1. The water in the model represents blood glucose. Which part of your model represents the pancreas? (Drawing a cycle like the one in Figure 2 might help you find an answer.) Give a reason for your answer.

**The fishing float represents the pancreas because it detects and controls the amount of water (glucose) in the system.**

---



---

**MODEL OF A NEGATIVE FEEDBACK MECHANISM** *(continued)*

2. Which part of your model represents the body cells? Give a reason for your answer.

The rubber ball represents the body cells. It reacts to the detection of too much water (glucose) by removing the excess.

3. Which part of your model represents insulin? Give a reason for your answer.

The string represents insulin, as it sends a message from the float to the ball.

4. Explain how your model demonstrates the negative feedback mechanism used by the pancreas to control glucose levels in the blood.

In the model, the float responds to the increased water level. In the body, the pancreas responds to an increase in the blood glucose level. The float responds by pulling the ball out of the bottle neck. The pancreas responds by producing insulin. Once the ball is out of the way, water escapes and its level drops. Once insulin is released into the bloodstream, the excess glucose in the blood is taken up by the cells, causing the glucose level to drop.

**◆ Critical Thinking and Applications**

1. How would lengthening the string between the float and the ball affect the water level? How would shortening this string affect the water level?

A longer string would stabilize the water at a higher level, and a shorter string would stabilize the water at a lower level.

2. Based on this model, explain how negative feedback works.

Negative feedback restores certain substances in the blood to “normal” levels. When a substance is above or below this level, the negative feedback mechanism triggers a response that restores the substance to its appropriate level.

### MODEL OF A NEGATIVE FEEDBACK MECHANISM *(continued)*

3. What part of the negative feedback mechanism that keeps blood glucose at one level is not represented in the model? How could you improve the design of the model to make it more accurate?

This model represents the part of negative feedback where too much glucose is present in the blood and the pancreas releases insulin until blood glucose levels drop to normal conditions. It does not represent the opposite condition, low blood glucose level. The model could be improved by adjusting it so that the water level (blood glucose level) could go lower than the standard and the mechanism would restore the water level to normal.

#### ◆ More to Explore

The body's regulation of glucose levels is more complicated than the model you made of it. Use the library to find out more about glucose regulation. Which part of the regulation process is missing from your model?

The missing pieces are storing glycogen in the liver and releasing it as glucose when blood glucose is low. The hormone glucagon controls this process.

**LAB 17**

**LABORATORY INVESTIGATION**

# Ecosystem Food Chains

**Key Concept:** All ecosystems have biotic and abiotic factors, which affect the way energy flows through the ecosystem.

**Skills Focus:** Observing, classifying, measuring, creating data tables, inferring

**Time Required:** two 40-minute classes

## ◆ Pre-Lab Discussion

Ecosystems are made up of both living (biotic) and nonliving (abiotic) things. Energy moves through ecosystems in the form of food. When an organism eats another organism, it obtains energy from the food. A food chain is a series of events in which one organism eats another and thereby obtains energy.

Do you know what makes up the ecosystems in your area? In this investigation, you will become an ecologist studying a local ecosystem. You will observe and collect data about the biotic and abiotic factors found at your site. You will also study the relationships among the different biotic and abiotic features you observe.

1. What is a consumer? What are the four classifications of consumers?

**A consumer is an organism that eats another organism to get its energy. The four classifications of consumers include herbivores, carnivores, omnivores, and scavengers.**

2. What is the source of all the food in an ecosystem? What process is generally used to make this food?

**Producers are the source of all the food in an ecosystem. Most producers make sugars using the process of photosynthesis.**

## ◆ Problem

What food chains can you observe in a local ecosystem?

## ◆ Possible Materials *(per group)*

- |             |                 |
|-------------|-----------------|
| meter stick | colored pencils |
| 4 stakes    | hand lens       |
| string      |                 |
| notebook    |                 |
| pen         |                 |

**Advance Preparation:** Investigate different sites near the school where students could do the field study. You may wish to combine this lab with a field trip to a nature center or to another natural environment, which could provide students with a variety of ecosystems to study.

**Find out if students have allergies that might be of special concern for this lab. Stress that students with allergies to certain plants observe their site without touching the plants.**

## ◆ Safety Review the safety guidelines in the front of your lab book.

Use care when working with stakes. Be careful when working around land and water sites so that you do not fall and injure yourself or others. Review the safety rules on pages v–vi in the front of this book for handling plants and animals.

**ECOSYSTEM FOOD CHAINS** *(continued)***◆ Procedure****Part A: Class Preparation**

1. As a class, discuss the different types of ecosystems found around your home and school. Determine which ecosystem you will examine. Be aware that the type of ecosystem you choose will influence the types of food chains you will find.
2. Use different colored pencils to represent the different types of organisms you expect to find within your chosen ecosystem. Make a key representing the different organisms in the Data Table under Observations. Types of organisms might include trees, bushes, flowers, grasses, mosses, fungi, insects, and other animals. You might also include evidence of animals, such as burrows, nests, and egg cases. Finally, consider including dead organic materials such as logs, dead trees, fallen leaves, and animal remains.
3. Make a list of the materials that you need to conduct your field study of the ecosystem. Develop a plan for gathering these materials. Decide who will gather what materials.

**Part B: Field Study**

1. At your study site, measure a 25-square-meter site with a meter stick ( $5\text{ m} \times 5\text{ m}$ ). Place one stake at each corner of the site. Loop string around one stake and continue to the next stake until you have formed the boundaries for the site. See Figure 1.
2. On a separate sheet of paper, draw a map of your site. Draw the abiotic features on your map, such as streams, sidewalks, trails, or boulders.
3. Draw colored circles on the map to represent the different organisms you find. Some of your circles will likely overlap. For example, if your site is mostly grass, you may have a colored circle around the entire map. Within this circle might be other colored circles representing trees.
4. Observe your site quietly for 30 minutes. On a separate sheet of paper, record any interactions between organisms that you observe. Such interactions may include getting food or just moving across the site.
5. When you have finished your observations, remove the string and stakes. Leave the site as you found it; do not take anything from it or damage it in any way.

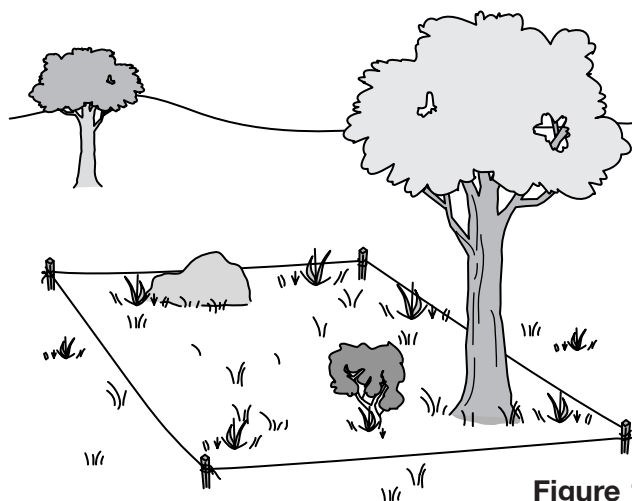
**Figure 1**

**Teaching Tips:** You might want to suggest sites with a variety of abiotic features, for example, with both sloping and level ground and with both sunny and shady areas. Encourage different groups to study sites with different features. You may be more comfortable assigning sites rather than letting students choose. As students observe their field site, remind them to be as quiet and as still as possible to improve their chances of observing sensitive biotic factors.

**ECOSYSTEM FOOD CHAINS** *(continued)*

**◆ Observations**

Data Table

Sample Data

<i>Color Key for Organisms</i>			
<i>Color</i>	<i>Type of Organism</i>	<i>Color</i>	<i>Type of Organism</i>
Medium green	Trees	Brown	Evidence of dead animals
Red	Flowers	Blue	Animals
Light green	Bushes	Black	Dead materials
Yellow	Grass	Orange	Fungi

**◆ Analyze and Conclude**

1. What producers did you observe at your site? What characteristics do these organisms have in common?

Producers may include a variety of trees, bushes, flowers, mosses, and grasses. All the producers at the site are plants and make sugars through photosynthesis.

2. Think about the consumers you observed at your site. Categorize them according to the four main types of consumers that you listed in Pre-Lab question 1.

Answers will vary based on the animals students observe in their ecosystem. Common herbivores include certain insects, caterpillars, mice, squirrels, and rabbits; common carnivores include spiders, hawks, owls, and foxes; common omnivores include raccoons and most birds; common scavengers include vultures and crows.

3. What are the most important abiotic features of your site? Explain your answer.

Answers will vary depending on the site. Students might discuss water sources, slope or drainage of the site, amount of sunshine the site receives, or presence of human-made features as important abiotic features.

## ECOSYSTEM FOOD CHAINS *(continued)*

### ◆ Critical Thinking and Applications

1. Draw two food chains you observed in your site that contain a producer, a primary consumer, and a secondary consumer. Include appropriate organisms in your drawings even if you did not observe the actual consumption of food.

Answers will vary. Food chains generally include: producer→herbivore→carnivore→top carnivore→decomposer. Sample food chains include: (a) grass→grasshopper→bird→fungi; (b) tree→insect→spider→bird→fungi; (c) tree→beetle→fungi; (d) tree→insect→spider→frog→fungi; (e) plant→rabbit→fox→bacteria; and (f) phytoplankton→snail→bluegill fish→bass→fungi.

2. How do the abiotic factors in your ecosystem affect how the living things in the ecosystem are distributed?

Answers will vary. For example, fewer plants may be found on sloping land where the soil has eroded, or more plants may be found near a stream where water is abundant.

3. What would happen to the producers and consumers at your site if there were no decomposers?

Raw materials, such as water and minerals, would not be returned to the environment for use by other organisms. Also, wastes and dead organisms would pile up and overwhelm the environment.

4. Predict how the biotic and abiotic features might change at your site during different seasons.

Answers will vary but might refer to changes in sunlight, temperature, and precipitation; changes in animal populations due to migration and hibernation; and changes in the process of photosynthesis depending on whether trees have leaves.

### ◆ More to Explore

Compare your site to other sites nearby. Consider both biotic and abiotic features. Also describe any evidence of human influence on your site.

Sites in proximity to one another generally have similar biotic and abiotic features unless there is a distinct change in terrain, such as a body of water or a severe change in topography. Evidence of human influences may include litter and other signs of pollution, sidewalks and other products of construction, and landscaping. If students' sites are at a park, the trees in the park were likely planted by people.

**LAB 18** **LABORATORY INVESTIGATION**

# Family Life of Bettas

**Key Concepts:** Instinctive behaviors enable betta pairs to breed.

**Skills Focus:** Observing, classifying, inferring, posing questions

**Time Required:** two 40-minute periods for setting up the fish containers; 10–15 minutes for observation each day for up to 2 weeks

## ◆ Pre-Lab Discussion

Betta fish, also known as Siamese fighting fish, live in fresh water and originally came from Southeast Asia. These beautiful aquarium fish are usually red, blue, or turquoise. The males' colors become brighter when the fish are courting or get excited. Bettas do not get all their oxygen from water; they rise to the surface from time to time for air. They can live in containers without special pumps or filters.

In this investigation, you will select a male and a female betta fish, set them up in a container, and observe them to see if they will produce a batch of eggs that will hatch into tiny fish, called fry. During your investigation, remember that fish, like all other living organisms, must be handled with care. The containers that you will be using must be filled with tap water that has been sitting for at least 24 hours. The water should be changed once a week. Floating aquatic plants must be present when both male and female bettas are in the same container. The fish prefer low light, and the water should be kept between 21°C and 29°C (70°F and 84°F). Betta fish should be fed a pinch of food twice a day. Male bettas are extremely territorial and **MUST** be kept out of sight of one another.

1. What type of behavior is courtship—instinctive or learned? Explain your answer.

*Courtship is an example of instinctive behavior. An instinct is an inborn behavior pattern that the animal performs correctly the first time.*

2. Betta males are very aggressive toward one another. What is aggressive behavior?

*Aggressive behavior is threatening behavior that one animal uses to influence the behavior of another.*

## ◆ Problem

What behaviors enable betta fish to reproduce?

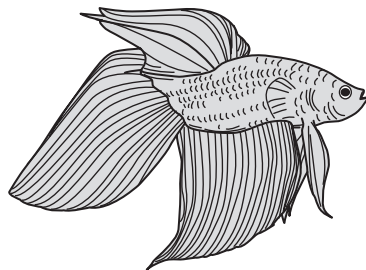

**Advance Preparation:** To augment the information in this lab, consult the book, *Bettas—A Complete Introduction* by Walt Maurus (T.F.H. Publications, Inc. 1987).

The recommended total number of breeding pairs for an entire class is six.

Male bettas are extremely territorial and must be kept in separate containers before being paired with a female.

Betta food can be purchased at a pet store. One container will be enough for the entire class.

Make plans for continuing care of the fish after the lab. Most pet stores will buy betta fry from you if students do not want to take them home.



**FAMILY LIFE OF BETTAS** *(continued)***◆ Possible Materials** *(per group)*

colored pencils  
 2 clean 2-liter soda bottles filled  
 with aged water  
 1-gallon or larger container filled  
 with aged water  
 aquarium gravel  
 floating clump of aquatic plants  
 betta food  
 male and female betta fish  
 hand lens

**Alternate Materials:** Many different containers can be used in this activity, including large glass jars, 2-liter plastic bottles, and gallon milk containers. If bettas are not available, use gouramis instead. Test members of any other species for willingness to breed before using them in the lab.

**Teaching Tips:**

Keep males out of each other's sight and away from reflecting surfaces. To compensate for possible pH, hardness, and temperature extremes in local tap water, the water should sit for at least 24 hours before putting fish in it. Fresh tap water also contains chemicals that can kill the fish.

**◆ Safety**   Review the safety guidelines in the front of your lab book.

Wash your hands after handling the fish.

If eggs are not laid by three days after the fish are introduced, new partners should be tried.

**◆ Procedure**

1. Read the entire lab before continuing your investigation.
2. Brainstorm with other students on how to use the materials to set up a container for your fish to live in. Have the teacher approve your plans before you set up these containers with your fish.
3. Place your male and female bettas in separate containers for one or two days. Sketch the fish in Observations and record their behaviors in the Data Table. Observations may include periods of inactivity, gill movements, how the fish swims, and which fins it uses in different maneuvers. Note differences in the sexes, gill movements, and fin and tail formation.
4. After one or two days, introduce both fish into a larger breeding container. Observe your fish for 10 minutes every day, for up to two weeks. Watch for the events listed below. You may not see every event take place. Compare your observations with those of your classmates. Record all of the fish's behaviors each day and answer the questions in Observations.
  - initial reaction of the male and female bettas after being introduced into the same container
  - initial courtship behaviors
  - male building nest (between 24 hours and 5 days after introduction to female)
  - female approaching male and laying eggs
  - care of eggs
  - hatching of eggs into fry (Eggs hatch within 24 to 28 hours of being laid.)  
Use a hand lens to check the eggs in the water. Fry are very small and may be difficult to see without magnification.
  - care of fry by adults

## FAMILY LIFE OF BETTAS *(continued)*

5. When your observations are complete, plan with the teacher how to continue to care for the fish.

### ◆ Observations

#### Sketch of Male and Female Fish

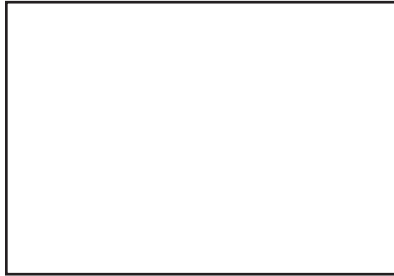

*Male betta*

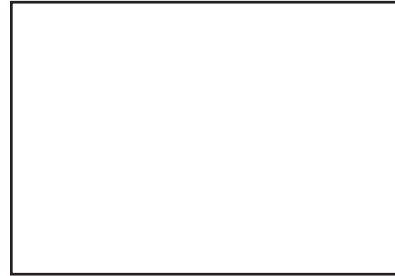

*Female betta*

1. After placing the male and female fish into the same container, what happens to the bodies of the male and female fish when they first notice each other?

*Fins and gills are spread wide and the fish's colors become brighter. The female body's horizontal bar pattern (if present) is replaced by one of vertical bars.*

2. What types of courtship behaviors do the fish show?

*Initially the fish may swim side by side at different times. Then the male becomes more aggressive. He may slap or lunge at the female and attempt to bite her. The female dodges these lunges and is usually not harmed as she hides among the aquatic plants.*

3. While the male betta is building the nest, how do the behaviors of the two fish change?

*The male stops attacking the female and attempts to lure her to the nest. He approaches the female from the side. His fins and gills spread and he wags his body back and forth in an "S" shape. He then approaches his nest. This may occur several times with the male nipping the female if she refuses to come to the nest with him.*

4. What behavior occurs before the eggs are laid and while the eggs are being laid?

*The female approaches the male in a submissive way with her head pointed downward. The male spreads his gills and fins and becomes gentle. The two fish circle and touch each other's sides with their noses. The female is upside down and the male is on his side. His body is curved over hers. It may take several of these embraces before eggs begin to drop.*

**FAMILY LIFE OF BETTAS** *(continued)*

5. How do the adult bettas take care of the nest, eggs, and fry?

The male generally takes over all of the caretaking duties. He pushes the eggs into the nest by placing them in his mouth. He continues working on the nest, making any repairs or enlarging as necessary. After hatching, the male corrals the fry into the nest area.

---



---

**Data Table**

<b>Day</b>	<b>Behavior Observations</b>	
	<b>Male</b>	<b>Female</b>
<i>1–2; fish in separate containers</i>		
<i>3; fish are put into one container</i>		

© Prentice-Hall, Inc.

## FAMILY LIFE OF BETTAS *(continued)*

### ◆ Analyze and Conclude

1. Did your bettas successfully reproduce? If not, suggest some possible reasons the pair did not breed.

Betta breeding was successful if fry are in the tank. If breeding was not successful, perhaps the tanks were not properly prepared and maintained for the bettas. However, animal behavior is not entirely predictable—sometimes pairs are not attracted to each other.

2. Why are the courtship behaviors of the male and female bettas important?

The courting behaviors ensure that males and females of the same species recognize one another, so that they can reproduce.

### ◆ Critical Thinking and Applications

1. Why are the floating plants important to the female betta?

The female betta often uses the plants to hide from the male betta's attacks. They also supply oxygen.

2. What methods could be used to prevent the male from hurting the female?

Methods may include using a much larger container with several aquarium objects on the bottom of the container. A glass or plastic partition could be used to separate the two fish or the female could be placed in a smaller, transparent container such as a jar. This jar could be floated in the container holding the male betta.

3. Based on this investigation, what other questions might you like to investigate?

Possible questions could include: Do male bettas prepare bubble nests when females are not present? What happens when two females are in the breeding container? Do the females ever participate in caring for the eggs and fry?

## FAMILY LIFE OF BETTAS *(continued)*

### ◆ More to Explore

**New Problem** Choose the response that interests you most from question 3 of Critical Thinking and Applications. Plan to investigate this problem.

**Possible Materials** Consider which materials you can use from this lab. What other materials might you need?

**Safety** Wash your hands after handling fish.

**Procedure** Make a hypothesis based on the question you want to investigate. Upon what do you base your hypothesis? Write your procedure on a separate sheet of paper. Include a control with which to compare results. Have the teacher approve your procedure before carrying out the investigation.

**Observations** Make a data table similar to the one for this lab.

### Analyze and Conclude

1. Did your results support your hypothesis? Explain your answer.

Answers will vary depending upon the question being investigated. Accept all reasonable answers.

2. Evaluate your procedure. What worked well? If you were to repeat this experiment, what parts of the procedure would you change?

Answers will vary. Areas to be changed may include the physical setup of the fish container, the physical condition of the fish used, lack of an adequate control, or improper lighting and water temperature.

Help students design experiments that have clearly defined variables and controls, so that they will get valid results. Students may have to compare the results of their investigations to their previous investigations or to the investigations of other class members. Remember to check students' procedures before allowing them to begin their investigations.

**LAB 19** **LABORATORY INVESTIGATION**

# Managing Fisheries

**Key Concepts:** Living resources must be managed wisely to keep the populations at a level that will provide adequate supplies for future generations.

**Skills Focus:** Observing, inferring, making models, communicating, forming operational definitions

**Time Required:** 40 minutes

## ◆ Pre-Lab Discussion

When explorers first came to the shores of North America, they were amazed at the abundance of resources—towering forests, clear streams, vast grasslands, and a large variety of wildlife. As they began to use these resources, they also began to affect them. Throughout the years, populations of plants and animals have increased and decreased as a result of both natural events and human actions.

One example of a population that has changed over the years is fish. The waters off the shores of North America have supplied large quantities and varieties of fish. Overfishing and other abuses of the fishing areas have caused the populations to greatly decrease. But people are also taking action to protect the fish. In this investigation, you will model a population of cod fish off the Grand Banks—a famous fishing area off the coast of Newfoundland, Canada. You will determine the effect of different events on that fish population.

1. Is a fishery a renewable resource or a nonrenewable resource? Explain your answer.

**It is a renewable resource because the fish population may replenish itself within a short period of time.**

2. Aquaculture is the farming of water organisms. How might increased aquaculture of fish in an area help the local fisheries? How might it harm them?

**Answers might include the following. The variety of local fish might increase and depletion of fisheries would be less likely. It may replace natural habitats, can cause pollution, and can spread disease.**

## ◆ Problem

How does a fish population change over time?

## ◆ Materials *(per group)*

- notebook paper, 1 sheet
- colored construction paper, 8 sheets of one color
- scissors
- pencil or pen
- set of event cards

**Advance Preparation:** Use colored construction paper to prepare one set of event cards for each student group. These cards must be a different color than the fish cards. Write “Event” on one side of each card. Write one of the events listed on page 88 of this book on each card. You can use other events if you prefer.

**Alternative Materials:** Colored index cards can be used instead of sheets of colored paper for the fish cards and event cards.

## MANAGING FISHERIES *(continued)*

◆ **Safety**  Review the safety guidelines in the front of your lab book.

Use caution when cutting with scissors.

### ◆ Procedure

1. As a group, make 8 “fish cards” from each sheet of colored paper, for a total of 64 cards. Write “Fish” on one side of each card. These fish cards represent the population of cod in fisheries off the Grand Banks. Each card represents many fish.
2. Divide a sheet of notebook paper in half. Label one half “Live Fish” and the other half “Dead Fish.”
3. Obtain a set of event cards from your teacher. These cards represent events that can affect a fish population.
4. Shuffle and spread out the event cards, facedown. Count off 25 fish cards and place them by the notebook paper, as shown in Figure 1. Set the remaining 39 fish cards aside.

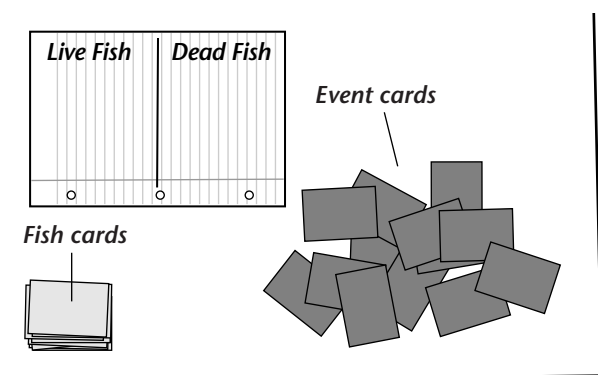

**Figure 1**

#### Teaching Tips

- Groups of three students each work well for this activity. Be sure each student participates.
- Be sure students justify their decisions as to why an event will likely increase or decrease the fish population.
- Discuss with students why it is important to replace the event card after each turn. (Similar events can reoccur.)

5. Pick up an event card. As a group, discuss and decide if the event you have chosen will likely increase or decrease the fish population.
6. If the event will increase the population, place a fish card from the stack of 25 on the Live Fish area of the notebook paper. If it will decrease the population, place a fish card on the Dead Fish area of the paper.
7. Replace the event card and mix up the event cards again.
8. Repeat this procedure until all 25 of the fish cards have been placed on either live or dead fish piles on the paper.
9. Count the number of live fish cards on the paper. Add half that number of fish cards from the remaining 39 cards to the live fish stack to represent additional fish added by reproduction. Remove the dead fish cards and set them aside with the remaining fish cards. Complete the Data Table in the Observations section for Generation 1.

**MANAGING FISHERIES** *(continued)*

- 10. The stack of live fish cards now represents the beginning of the second generation of fish. Repeat steps 5–9 to find out what happens to the second generation of fish.
- 11. Repeat steps 5–9 to find out what happens to the third generation of fish.

**◆ Observations**

**Data Table**

**Sample Data**

<i>Starting number of fish cards: 25</i>		
<b>Generation</b>	<b>Number of Live Fish Cards at End of Generation Before Reproduction</b>	<b>Number of Fish Cards After Reproduction</b>
1	15	23
2	12	18
3	13	20

**◆ Analyze and Conclude**

- 1. How did your fish population change over time?

*Answers will vary but should compare the 25 fish at the beginning of the activity with the ending number for generation 3 and mention any trends in population change.*

---

- 2. Compare the number of fish at the end of each generation. Explain your results.

*Answers will vary but should reflect the data from the Data Table.*

---

- 3. What are some ways this investigation models natural selection?

*This investigation is like natural selection because it reflects changes in fish population based on natural environmental factors.*

---

- 4. What are some ways in which natural selection differs from this model?

*This investigation is unlike natural selection because human factors affect the fish population also.*

---



## MANAGING FISHERIES *(continued)*

### ◆ Critical Thinking and Applications

1. How would fishing crews using a net with a large mesh affect the fish population compared to fishing crews using a net with a small mesh?

Large mesh allow small fish to escape. Large fish are captured, leaving the small fish to grow and reproduce, thus allowing the fish population to remain steady or grow. Small mesh would capture a greater variety of sizes of fish. This would decrease the fish population because fewer young fish would be left to reproduce.

2. List two other factors not listed in the questions or on the event cards that would affect the fish population.

Answers will vary but might include climate and salinity changes.

3. Think about the effect that an increase in the predator population has on the fish population. Does this effect apply to all animal populations? Explain your answer.

Populations of all animal species decrease when the population of predators increases because there is more competition among the predators for resources such as food and habitat.

### ◆ More to Explore

Choose a different species to investigate. Make your own set of event cards and a data table. Be sure some events will likely increase the population and some will likely decrease it. Repeat the activity, using your event cards and data table. Write a paragraph explaining your results.

**Students can work individually or in groups. Be sure students choose events applicable to their chosen species. Some events can be the same as those used for the fish, but some should vary. One strategy is to have students choose different species and compare and contrast how their populations are affected by the same events.**

Events for event cards:

Fishing areas are overfished.

Organizations of fishers place limits on the number of fish that can be caught.

Laws state that young, small fish can now be caught.

Laws state that fish smaller than a certain size must be released back into the water.

Water of fishing areas becomes polluted.

Water pollution in fishing areas is cleaned up.

Predator population increases.

Predator population decreases.

Another species is introduced that competes for the same food source as fish.

The population of a species that eats the same food decreases.

Only licensed fishers can catch fish.

Unlicensed fishers illegally catch fish.

Aquaculture cuts down on the number of cod caught.

Aquaculture introduces disease into the fish population.

Laws are enacted to protect the fish population.

Laws to protect the fish are broken.