

Student Name \_\_\_\_\_

Teacher Name \_\_\_\_\_

School \_\_\_\_\_

System \_\_\_\_\_

# ACH



# TENNESSEE

LENNESSEE

## Tennessee Comprehensive Assessment Program Achievement Test ~ Grade 6 Practice Test



**PEARSON**

Developed and published under contract with Tennessee State Department of Education by the Educational Measurement group of Pearson, a business of NCS Pearson Inc. 2510 North Dodge Street, Iowa City, Iowa 52245. Copyright © 2012 by Tennessee State Department of Education. All rights reserved. No part of this publication may be reproduced or distributed in any form or by any means, or stored in a database or retrieval system, without the prior written permission of Tennessee State Department of Education.

# Table of Contents

<b>Introduction</b> .....	1
What is the TCAP Achievement Test?.....	1
What are the questions testing?.....	1
Who will be tested?.....	1
How long will the tests take? .....	1
How will the tests be scored?.....	1
May calculators be used?.....	1
Which test accommodations may be used?.....	2
What is the purpose of the practice test? .....	2
Here are some tips for preparing students for the test.....	2
<b>Reading/Language Arts</b> .....	3
<b>Mathematics</b> .....	53
<b>Science</b> .....	89
<b>Social Studies</b> .....	129
<b>Answer Key</b> .....	164



# Introduction

## **What is the TCAP Achievement Test?**

The TCAP Achievement Test is a multiple-choice test designed to measure student achievement in certain skills in four content areas: Reading/Language Arts, Mathematics, Science, and Social Studies. The questions in this practice test are examples of items used in the actual test.

## **What are the questions testing?**

Questions are written to test student performance in state content standards. The State Content Standards and Performance Indicators were developed by the Tennessee Department of Education. These Standards and Performance Indicators are listed on the State Department of Education Web site at <http://www.state.tn.us/education/curriculum.shtml>.

## **Who will be tested?**

Students in grades 3 through 8 will be tested.

## **How long will the tests take?**

The length of the tests will vary, depending on the grade level. The time limits are generous and allow most students time to finish. Extended time limits only apply to students who are eligible for special or English Language Learner (ELL) accommodations.

## **How will the tests be scored?**

The test answers will be machine scored. Results from the test provide information about how well students performed on the content being tested.

## **May calculators be used?**

Calculators may be used on Part 1 and 2 of the mathematics portions of the TCAP Achievement Test (grades 3–8) as per system policy.

## **Which test accommodations may be used?**

The TCAP Achievement Test may be administered using various procedures that are used during the student's daily educational program. Certain conditions must be met for students to be eligible for Special and ELL accommodations.

## **What is the purpose of the practice test?**

In a classroom learning session, these questions can be used to prepare students for the actual test. Teachers can use the practice test to help familiarize students with the format of test questions and how the actual test will be administered. This practice test can also be used to inform parents of the type of test their children will be taking.

## **Here are some tips for preparing students for the test.**

Remind students to:

**Relax**: It is normal to be somewhat anxious before the test. Remember that the score is only one of a number of measures of performance.

**Listen**: Listen to and read the test directions carefully.

**Plan Use of Time**: First, answer all the questions you are sure about. Do not spend too much time on any one question. If a question seems to take too long, skip it and return to it later if you have extra time.

**Pause and Think**: If you are not sure how to answer a question, carefully read it again. Rule out answer choices that you know are incorrect and then choose from those that remain.

# Reading/Language Arts

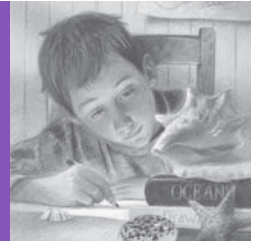

## Part 1

**Directions** Read the passage. Then answer Numbers 1 through 7.

### Overloaded

- 1 Mariah watched as the basketball swooshed through the net at the edge of the driveway.
- 2 “Great shot,” applauded her brother, Jonathan.
- 3 “Thanks,” replied Mariah. The ball bounced back, and Mariah shot it into the air. It swished through the net once more.
- 4 “You need to give me lessons,” said Jonathan. He grabbed his own basketball and sent it hurtling through the air like a cannonball. It hit the rim of the basket with a thud and bounced into the hedge.
- 5 “Here’s a tip—aim the ball.” Mariah smiled as she glanced at her watch. “I have to practice my flute. Maybe I can help you later.”
- 6 Jonathan nodded as his next shot bounced off the rim again. His sister was the star player on her basketball team, but Jonathan had decided he didn’t possess any of her talent. Jonathan sighed and shook his head.
- 7 “Don’t give up,” Mariah encouraged him as she hurried inside the house. Part of her wanted to stay and coach him, but she had to practice her flute for the upcoming band concert.
- 8 When Mariah got to her room, she rummaged through her backpack, searching for her music folder. It was missing. Mariah groaned as a feeling of disappointment washed over her. She’d been in such a hurry to help paint the sets for the middle school play on Friday afternoon that she left her music folder in the band hall.
- 9 A moment later, the phone rang, and Mariah ran to answer it. Her friend Elizabeth reminded her they were working on the sets for the play again that afternoon.
- 10 “Come and help,” Elizabeth invited.

Go On ►

11 “I’m on my way,” Mariah said, hanging up the phone. Mariah took a plastic water bottle from the kitchen cabinet. Then she grabbed the can of lemonade powder sitting on the counter and hastily poured a scoop of the mix into her water bottle and filled the rest of the bottle with tap water from the kitchen sink. She put the lid on the bottle and shook it as she ran out the door. A twinge of regret tugged at her. Somehow, her day had managed to get two steps ahead. *When would she have time to practice her flute?*

12 Mariah walked across the street to her school and found a group of students working outside the theater building. Elizabeth was painting cardboard trees. Other students were constructing a drawbridge, while another group was painting a backdrop.

13 Mariah picked up a paintbrush, dipped it in a can of dark green paint, and began to help Elizabeth paint. *Maybe if we work fast, we’ll finish the trees today,* Mariah thought as she brushed back and forth like a windshield wiper. Then without meaning to, she bumped her paint can. She gasped as it tumbled down and exploded on the cement with a giant, green splat.

14 “Quick! I need some rags!” shouted Mariah, and Elizabeth scrambled to her rescue. The green puddle oozed across the pavement. Elizabeth had two rolls of paper towels and a bucket of water. It took the girls fifteen minutes to wipe up the green blob.





15 “Thanks for your help,” Mariah said when they finished. Then Mariah grabbed her water bottle for a quick drink. She took a gulp of her lemonade and suddenly gasped. She was expecting a tangy, sweet liquid, but the lemonade was sickly sour. Mariah sighed as she closed the lid. She’d been in such a hurry that she hadn’t measured the lemonade powder, and she had added way too much.

16 As Mariah held the bottle up to catch the sunlight, she realized she’d added too much to her own life too. She was trying to play basketball, learn her flute music, and paint the play sets. She’d added too many activities! Instead of enjoying everything, she felt like she was sprinting from one task to the next, in a never-ending relay race.

17 Mariah spoke suddenly. “Elizabeth, I’m going to pass on painting anymore props. It’s fun, but I think I’ll have to wait until next year to test my artistic talents.”

18 “Okay,” Elizabeth agreed, waving goodbye to her friend. As Mariah turned to leave, Elizabeth piped up, “Mariah, wait! I nearly forgot! You left your music folder in the band hall on Friday. I thought I might see you this weekend, so I picked it up for you.”

19 More relieved now, Mariah sprinted home with her music. She found Jonathan sitting on the porch steps with his basketball. His shoulders drooped.

20 “What’s wrong?” inquired Mariah.

21 “In ten shots, I only made one basket,” he grumbled.

22 Mariah smiled patiently. “I shoot a hundred baskets every day,” she explained.

23 “A hundred?” squeaked Jonathan with wide eyes. He’d never realized how much Mariah practiced. His sister wasn’t just lucky, she worked hard—and he could do that too.

24 “Are you ready to shoot some hoops?” asked Jonathan wistfully.

25 “I’ve got twenty minutes,” offered Mariah, “and then I’ve got some serious practicing to do.”

26 Jonathan leapt up as if his legs had springs.

27 Mariah laughed. For now she planned to concentrate on her basketball and her flute. Then she’d be able to do both things well and still have plenty of time for one little brother too.

**1** Read this sentence from Paragraph 8.

*When Mariah got to her room, she rummaged through her backpack, searching for her music folder.*

Which word is a synonym for rummaged?

- A looked
- B passed
- C dodged
- D moved

**2** Which word completes the analogy?

*Walked is to sprinted as drank is to \_\_\_\_\_.*

- F poured
- G sipped
- H gulped
- J emptied

**3** The reader knows this passage is written in the third person because

- A Mariah tells the story in her own words.
- B Jonathan tells why he is unhappy with Mariah.
- C the narrator reveals the experiences of the characters.
- D the narrator reveals his or her own experience.

**4** If the passage continues, what will Mariah most likely do next?

- F** try out for the next school play
- G** spend more time playing her flute each week
- H** take a class in painting so she can help Elizabeth
- J** tell Jonathan about why she is good at playing basketball

**5** Why did the author most likely write this passage?

- A** to persuade readers to show interest in hobbies
- B** to entertain readers with a lesson about managing time
- C** to compare different activities that students enjoy
- D** to inform readers about the mistakes a girl makes

**6** Read this sentence from Paragraph 4.

*He grabbed his own basketball and sent it hurtling through the air like a cannonball.*

The author uses the simile to show that Jonathan threw the ball

- F** cautiously.
- G** very hard.
- H** skillfully.
- J** with grace.

**7** Read Paragraph 17.

*Mariah spoke suddenly. “Elizabeth, I’m going to pass on painting anymore props. It’s fun, but I think I’ll have to wait until next year to test my artistic talents.”*

Look at the dictionary definitions below for the word pass.

**pass** (verb) **1.** to go from control, ownership, or possession of one person or group to another **2.** to sit in judgment **3.** to go from one quality, state, or form to another **4.** to let something go without taking advantage of it

Choose the definition of pass that is used in Paragraph 17.

- A** Definition 1
- B** Definition 2
- C** Definition 3
- D** Definition 4

## Directions

Read the passage. Then answer Numbers 8 through 12.

# Matchstick Wonders

by Barbara Kramer

1 Pat Acton has always enjoyed building things. As a kid, he built a fully enclosed tree house with glass windows and a stove for heat. His older brothers soon left their more traditional tree houses to hang out in Pat's.

2 Back then, Acton used his father's tools, and he sometimes got into trouble for not putting them back where they belonged. After he graduated from college, he had time for woodworking but little money to buy tools. That was when he remembered a news story that he had seen on television when he was young. It was about a man who used matchsticks to build a model of his farm.

### Matchsticks, Glue, and Patience

3 Acton bought two boxes of wooden matchsticks and some glue. Then he began work on his first project—a small country church with a high steeple. Other models followed, including a stagecoach, a steamboat, and a 1930s-style locomotive. Each was carefully constructed with matchsticks that were only two inches long. The work was slow, and it took a lot of patience. “You just have to take your time doing this,” Acton says. “You can't hurry.”

4 Acton enjoyed building the models, but he did not like cutting the sulfur head off each matchstick before he could use it. He contacted the manufacturer and learned that he could buy matchsticks without heads directly from the company. With that problem solved, Acton began making larger, more detailed models.

### Details plus Imagination

5 Many of Acton's pieces are of historical subjects, such as his model of the *Challenger* space shuttle. He uses the library and the Internet to find photos and other information to help him make sure the details are correct.

6 Other projects come from his imagination. His model of a crooked house started with the nursery rhyme about the “crooked man” who lived “in a little crooked house.” But Acton wanted to create more than just a crooked house. He wanted something bigger and more interesting, like the haunted houses in the Hardy Boys books he'd read as a child. He combined the two ideas and let his imagination go to work. “That was fun because I could do whatever I wanted,” he recalls. The result was a crooked mansion complete with a leaning tower.

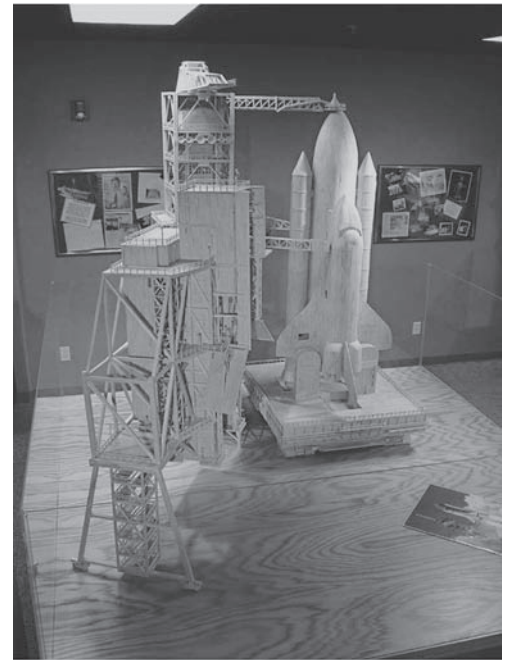

Acton dedicated his model of the *Challenger* space shuttle to the astronauts who lost their lives in its final mission.

Go On ►



It took almost 300,000 matchsticks and 1,000 hours of work to complete this model of a crooked house.

- 7 Because there are so few people who build with matchsticks, Acton has learned his art through trial and error. “I’m always learning new things,” he says. He was able to make his model of Pinocchio only after he learned to bend matchsticks. He uses needle-nosed pliers to pinch the matchstick, making small breaks in some of the wood fibers. Then he gently bends the matchstick into the curve he wants and glues it into place. When the glue is dry, he uses sandpaper to smooth the broken fibers.
- 8 Currently, Acton is working on a model of Hogwarts Castle, from the Harry Potter books. He says that he will never run out of ideas. He continues to explore this unique art form, turning matchsticks and imagination, glue and patience into wonderful creations.

“Matchstick Wonders” by Barbara Kramer, photos by Pat Acton, from *Highlights for Children*, Aug. 2006, copyright © 2006 by Highlights for Children, Inc. Columbus, Ohio. Used by permission.

**8** Read the list of steps Acton used for bending matchsticks.

1. *Glue them into place.*
2. *Bend the matchsticks.*
3. *Pinch the matchsticks with pliers.*
4. *Make small breaks in the wood fibers.*

Which is the correct order for the steps, as described in the passage?

- F** 1, 2, 4, 3
- G** 3, 4, 2, 1
- H** 4, 3, 1, 2
- J** 3, 2, 4, 1

**9** Which sentence from the passage is an opinion?

- A** As a kid, he built a fully enclosed tree house with glass windows and a stove for heat.
- B** “That was fun because I could do whatever I wanted,” he recalls.
- C** “I’m always learning new things,” he says.
- D** Currently, Acton is working on a model of Hogwarts Castle, from the Harry Potter books.

**10** Which message is communicated by the crooked-house illustration and its caption?

- F** You must be an adult to make matchstick models.
- G** You must have a background in building to make models.
- H** You must have time and energy to participate in this hobby.
- J** You must have a great deal of money to participate in this hobby.

Go On ►

**11** From the caption under the space shuttle photograph, the reader knows that Acton

- A** uses his talent to honor the sacrifices of others.
- B** accepts requests to create unusual pieces of art.
- C** inspires creativity in others with his art.
- D** seeks media attention for his hard work.

**12** If a student wants to find the names of other matchstick model makers, where should she or he look?

- F** an atlas
- G** a textbook
- H** the Internet
- J** the dictionary



**Directions** Read and answer Numbers 13 through 19.

**13** A student is writing a research paper about the history of flying. Which is the most appropriate research source for the student’s paper?

- A** a newspaper article about modern advances in flight
- B** a magazine article about new equipment used in flight
- C** an encyclopedia entry about the first experiments with flight
- D** an almanac entry about the weather conditions during a historic flight

**14** Read the ending of Kristin’s speech for the Student Council Representative election.

*“You should vote for me because I’m organized and dependable. Most of all, you should vote for me because I have such strong support from the sixth grade class. We are all together in this—don’t you want to be part of this winning team? Don’t get left behind: vote for me!”*

Which type of propaganda does Kristin use in her speech?

- F** name-calling
- G** testimonial
- H** bandwagon
- J** loaded terms

**15** Look at the train schedule.

Departing Station-Time		Arriving Station-Time	
Abbey	6:12 P.M.	Browne	6:32 P.M.
Browne	6:37 P.M.	Charles	6:49 P.M.
Charles	6:52 P.M.	Dunmore	7:06 P.M.
Dunmore	7:09 P.M.	Eldridge	7:19 P.M.
Eldridge	7:22 P.M.	George	7:46 P.M.
George	7:49 P.M.	Abbey	8:02 P.M.

If a passenger leaves Abbey Station on a train at 6:12 P.M., what time will the passenger arrive at George Station?

- A** 7:49 P.M.
- B** 7:46 P.M.
- C** 7:22 P.M.
- D** 8:02 P.M.

**16** Look at the set of instructions.

*How Many Jellybeans in the Jar? Contest Rules*

- 1. Fold your entry form in half and deposit it in the jar.*
- 2. Get an entry form from the front office and fill it out.*
- 3. Print your full name and your guess on the entry form.*
- 4. Write your phone number underneath your name and guess.*

What is the best order for the set of instructions?

- F** 2, 3, 4, 1
- G** 1, 4, 2, 3
- H** 2, 4, 3, 1
- J** 3, 2, 4, 1

**17** U. R. Buggin Pest Control Company owns a fleet of small red trucks with oversized mosquitos mounted on the roofs of the vehicles. The U. R. Buggin Pest Control Company is most likely hoping that, by using this artistic medium, it will

- A** amuse the public with unusual pest-control techniques.
- B** describe to the public how to control pests in homes.
- C** persuade the public to learn more about pests.
- D** inform the public about its local pest-control service.

**18** Look at the picture.



The girl in this picture appears to be

- F** surprised.
- G** outraged.
- H** modest.
- J** upset.

*Go On* ►

**19** Look at the picture.



© William Giakas/Stockphoto #2782213

**What can be inferred from the picture?**

- A** Communication is important for effective teamwork.
- B** Taking turns is necessary for success.
- C** Quick thinking is the best way to win a game.
- D** Sports provide healthy learning experiences for young people.

**Directions**

Read the speech. Then answer Numbers 20 through 26.

## Four Can Be Better Than Five

Members of the Green Valley School Board,

- 1 My name is Rick Smithfield. I am a sixth grader at Green Valley Middle School. I just moved to this area last summer. Many people might still consider me to be “new.” I have made many adjustments this past school year. I have seen how the teachers, staff, school board members, and the community work together to provide the best education possible for students at this school. I have nearly finished one school year here. I have had to get used to a more traditional approach to educating students. Today, I would like to share an idea with you. I hope you might consider it as part of your plans for the future of educating students like me in this community.
- 2 My idea involves moving away from a five-day school week and introducing a four-day week. We used this system in the last school I attended. My parents and I have seen the benefits this unique schedule provides. Additionally, the school district can continue to maintain the state educational standards.
- 3 By law, students are required to attend school 35 hours per week. Our current schedule divides this time into 7 hours on each of five school days. To create a four-day week, we would need to divide 7 more hours into these four days. This seems like a much longer school day. However, if we extended our school day from 7:15 A.M. to 4:00 P.M., it would give us the required 35 hours a week of school. I think most people would agree that this schedule still seems fairly traditional.
- 4 There are many advantages to having a four-day school week. Teachers would have an extra day to grade papers or create lesson plans. Teachers could also attend training classes and meetings or even make doctor appointments on this day. This would greatly reduce the need for teachers to miss class time. At school, having more time in class could benefit teachers too. They would have more time to extend their lessons or to work with students requiring extra help.
- 5 Students would benefit from this arrangement too. A longer school day would allow students to complete lessons, such as science experiments, without interruption. Also, an extra day off would allow students more time to work on projects or study for tests. Like teachers, students could also use this extra day to attend doctor appointments. The extra day might also allow families to spend more time together.
- 6 A four-day week can benefit the school financially too. The school could save money on utilities, such as lighting and heating on the days the school is closed.
- 7 Changing to a four-day week system may seem like an extreme idea at first. However, other school districts thrive with this schedule. I am sure that once the community and parents are made aware of some of the positive reasons for making this change, they will eagerly support a four-day school week. Please take the time to consider this idea, because it would truly benefit both the school and our community.

Go On ►

**20** The main purpose of Rick's speech is to

- F** explain how a four-day school week would work.
- G** convince school officials to consider a four-day school week.
- H** entertain his classmates with an interesting story about his previous school.
- J** describe how to make classes longer to have time for extra activities.

**21** Rick believes that altering the school day will be good for students and their families because they will

- A** be able to play more sports during the week.
- B** be able to do more family chores.
- C** have more time to be with family.
- D** have less homework to complete each week.

**22** The purpose of the last paragraph in this speech is to

- F** share an experience.
- G** suggest ideas.
- H** present more activities.
- J** provide a summary.

**23** Which sentence from the speech is a fact?

- A** By law, students are required to attend school 35 hours per week.
- B** There are many advantages to having a four-day school week.
- C** Students would benefit from this arrangement too.
- D** Changing to a four-day week system may seem like an extreme idea at first.

**24** Throughout the speech, the persuasive device Rick uses most is

- F** loaded terms.
- G** name-calling.
- H** bandwagon.
- J** testimonial.

**25** When giving this speech to the school board, Rick should

- A** speak clearly.
- B** read from notes.
- C** look at the back wall of the room.
- D** hold his hands behind his back.

**26** What would best help illustrate Rick's argument?

- F** a video of a class in session from his former school
- G** a giant calendar with every Friday marked in red ink
- H** an Internet Web site of a school district that has switched to a four-day week
- J** a PowerPoint presentation reporting student performance at a four-day school

**Directions**

Steven wrote the following report. It contains mistakes. Read it and answer Numbers 27 through 35.

## What Does the Nervous System Do?

- 1 How does the body know to breathe and move? The central nervous system tells the body what to do. It is just one of the systems of the human body. This is a very busy system because it is responsible for all the thinking humans do. It also controls all the voluntary movements of the body and the involuntary actions that keep a person alive, such as breathing, sleeping, and digesting food.
- 2 Where can people learn more about the central nervous system? There are many books that people can read to learn more about the central nervous system. The best book about the skeletal system is *Bones, Calcium, and You*. The Internet also offers a lot of information. Of course, people can also talk with doctors about this amazing body-messaging system.
- 3 How does the central nervous system work? Here is one example: if a person wants to kick a soccerball, the brain sends a message to the foot to kick the ball. The message is sent from the brain to the foot through nerves in the body. The spinal cord connects the brain with the nerves to send messages back and forth.
- 4 Do people have to think about everything their bodies do? The answer is no. Kicking a soccerball, jumping, or reading a book, are *voluntary* actions. The person knows he or she wants to kick the ball and thinks about it before it happens. Other actions are *involuntary*. People do not spend time thinking about breathing. It happens because of the central nervous system.

**27** Choose the most logical order for the paragraphs in this report.

- A** 1, 3, 4, 2
- B** 2, 3, 4, 1
- C** 3, 4, 2, 1
- D** 4, 2, 1, 3



**28** The main purpose of this report is to

- F** describe parts of the body that form the nervous system.
- G** provide information about the nervous system.
- H** persuade readers to learn more about the nervous system.
- J** explain how to care for the nervous system.

**29** Who is most likely the audience for this report?

- A** scientists studying the movement of the human body
- B** authors researching information about the human body
- C** teachers looking for facts about the human body
- D** students learning more about the human body

**30** Choose the best thesis statement for this report.

- F** The nervous system is a topic that is covered in many publications.
- G** The nervous system is just one of the many systems in the human body.
- H** The nervous system controls voluntary and involuntary responses.
- J** The nervous system controls human thinking, body movement, and functions.

**31** Read Paragraph 2.

*(1) Where can people learn more about the central nervous system? (2) There are many books that people can read to learn more about the central nervous system. (3) The best book about the skeletal system is Bones, Calcium, and You. (4) The Internet also offers a lot of information. (5) Of course, people can also talk with doctors about this amazing body-messaging system.*

**Choose the sentence that should be deleted from this paragraph.**

- A** Sentence 1
- B** Sentence 2
- C** Sentence 3
- D** Sentence 5

**32** Choose the best concluding sentence for Paragraph 3.

- F** Though many of our actions are voluntary, the central nervous system also carries out involuntary actions.
- G** When a person claps his or her hands, reads a book, or eats dinner, the brain sends these messages through the central nervous system.
- H** Other examples of involuntary actions are when the heart beats or when food is digested after a meal.
- J** The central nervous system is undeniably the busiest of all the systems of the body.

**33** Before Steven wrote his report, he thought of a list of topics to research. Choose the topic that is most focused.

- A** how blinking is both an involuntary and voluntary nervous-system response
- B** how the nervous system affects athletic performance
- C** historical explanations of the role of the nervous system
- D** nervous-system disorders and their treatments

**34** Steven wants to find more information about the central nervous system. Choose the source that will give him the most reliable information.

- F** a medical journal article about the central nervous system
- G** a diary entry from a person with a disorder affecting the central nervous system
- H** an Internet article about how poor digestion affects the central nervous system
- J** a Web site listing ways to protect the central nervous system

**35** When Steven is ready to present his report, what visual images could he add that would best enhance his presentation?

- A** names of books about the skeletal system
- B** photographs of himself sleeping, eating, and reading a book
- C** a scientific drawing of a human nervous system
- D** a sketch of a doctor listening to a patient breathe

**Directions** Read and answer Numbers 36 through 42.

**36** Which sentence uses quotation marks correctly?

- F** “The students sitting on the left side of the auditorium,” said Mr. Greene, “will need to stop by the office and make an appointment to discuss their schedules for next school year.”
- G** “The students sitting on the left side of the auditorium said Mr. Greene will need to stop by the office and make an appointment to discuss their schedules for next school year.”
- H** “The students sitting on the left side of the auditorium, “said Mr. Greene,” will need to stop by the office and make an appointment to discuss their schedules for next school year.”
- J** “The students sitting on the left side of the auditorium,” said Mr. Greene, will need to stop by the office and make an appointment to discuss their schedules for next school year.

**37** Which sentence contains an error?

- A** Your locker should be neat and organized.
- B** Turn in your permission slip by Tuesday.
- C** You're dog is barking at a squirrel.
- D** If you're able to stay, please tell us.

**38** Read the sentence.

All the students artwork was posted on display in the schools library.

Choose the correct punctuation for the underlined words.

- F** student's . . . schools
- G** students' . . . school's
- H** students . . . schools'
- J** student's . . . school's

**39** Read the sentences.

*Marc, Jalil, and Pablo were determined to get an “A” on the group project. Each of the students pledged to do their best.*

Choose the word that best replaces the underlined word.

- A his
- B our
- C its
- D correct as is

**40** Choose the sentence that is written correctly.

- F The cake looked delicious Melissa did not have a piece.
- G The cake looked delicious but Melissa, did not have a piece.
- H The cake looked delicious, Melissa did not have a piece.
- J The cake looked delicious, but Melissa did not have a piece.

**41** Read this sentence.

*When Jayda recieved invitations to visit fourteen college campuses, she knew that her years of dedication to her studies were finally paying off.*

Choose the word in the sentence that is spelled incorrectly.

- A recieved
- B fourteen
- C campuses
- D dedication

**42** Look at the picture.



Choose the statement that best summarizes the message of this picture.

- F** Students at graduation can expect to be successful in life.
- G** Graduation day is a proud event for a student and his family and friends.
- H** A student smiles for a picture on graduation day.
- J** Parents discuss plans for the future at the graduation for their son.

**STOP** 

**DO NOT  
MARK  
ON THIS  
PAGE**

## Part 2

**Directions** Read the drama. Then answer Numbers 43 through 49.

### Togetherness

**CHARACTERS:**

**MOM**

**DAD**

**BENNY**, age 11

**CHLOE**, age 6

*(Setting: Dinnertime, Tuesday, at the Williams' house.)*

**MOM:** Listen up, everybody. Let's think about what we want to do on Saturday.

**BENNY:** Saturday? But it's only Tuesday.

**MOM:** I know, but we never plan anything, and then our family doesn't get to do things together. Remember what we did last Saturday?

**BENNY:** No.

**MOM:** That's because we didn't do anything.

**DAD:** I mowed the lawn.

**CHLOE:** I rode my bike.

**MOM:** I was thinking more about *fun* things we can all do *together*.

**DAD:** I know! There's a playoff game on TV this Saturday. We can all watch the game.

**MOM:** You know I don't like football very much. I'm more of a basketball fan.

**DAD:** You're right, I need to remember that. Maybe you'd watch a little bit of the game with us?

**BENNY:** Whatever you decide, I'm not going to be able to join you.

**MOM:** Why, Benny?

**BENNY:** Because I have a school project that I have to complete this weekend.

**CHLOE:** Can't you do it later?

**BENNY:** No, I already put it off. I shouldn't have done that. Now I have to do it this weekend.



**MOM:** What's the project?

**BENNY:** It's about muscles. In science class, we're studying how muscles work. But I have no idea what I'm going to do for my project.

**DAD:** I guess that rules out a family weekend.

**MOM:** I guess so.

**CHLOE:** Why can't we do the project together?

**BENNY:** What do you know about muscles, Chloe?

**CHLOE:** Nothing.

**MOM:** Wait a minute. Maybe Chloe is on to something.

**CHLOE:** I am?

**DAD:** (*To MOM.*) Does "on to something" mean this is a project we could help Benny finish as a team? That would be a great family activity.

**MOM:** Do you remember going to the science museum last year?

**DAD:** Yes, I do because it was a day when each one of us had fun and learned a lot too.

**MOM:** Well, they had an exhibit on how the body works—how there are over 600 muscles in the body. Don't you remember that even the heart is a muscle?

**CHLOE:** I remember! They showed the inside of a stomach too. That was cool but maybe a little gross.

**MOM:** Well, we don't have to show the stomach muscles. Maybe Benny can use other muscles for his project.

**BENNY:** What do you mean?

**MOM:** You like making movies with your video camera, right?

**BENNY:** Sure. It's my favorite. Remember last month? I made a movie of your anniversary party.

**MOM:** Well, you can use your video camera to do another project with the family.

**BENNY:** What do you mean, Mom?

**MOM:** Make a film! However, you'll need our help. (*To CHLOE.*) Chloe, you like to ride your bike, right?

**CHLOE:** It's *my* favorite.

**MOM:** You can ride your bike while your brother films you. As he films, you can talk about how the muscles in your legs feel as they turn the pedals. You could even add a part about how tired they are when you have ridden for a long time.

*Go On* ►

**BENNY:** That's a good idea! The thigh muscles are called *quadriceps*. Chloe, think you can remember that word?

**CHLOE:** I can try.

**BENNY:** You can also talk about how the muscles in the rest of your body help you keep your balance . . . so you don't fall.

**CHLOE:** Fair enough.

**DAD:** What about me? You know my job has me reading so much that it might be good to mention the muscles that we use in our eyes.

**MOM:** That could be a problem because it wouldn't be very interesting to film your eyes moving from side to side for 2 to 3 minutes.

**DAD:** Hmmm, you're right. Filming eyes going back and forth would be pretty boring.

**MOM:** We need more than that. You could go outside and throw a football.

**DAD:** That would be fun and a good break from all the eye exercising I do!

**BENNY:** Great! I'll film you throwing while you talk about how the muscles in your arm and shoulder work together to help you make a perfect pass. Right?

**DAD:** What are those muscles called?

**BENNY:** The shoulder muscles are called *deltoids*, and the main ones in your arm are *biceps* and *triceps*.

**DAD:** Oh, right! I remember that.

**MOM:** It all sounds terrific.

**BENNY:** What will you do, Mom?

**MOM:** You can film me while I weed the garden and pick the ripe tomatoes and zucchinis. I'll talk about using my arm and leg muscles. I'll also mention that kneeling, bending, and standing up build muscle strength and balance.

**BENNY:** So, it's decided. This is going to be a cool project. I have the very best family. Thank you all for your help.

**MOM:** See how things are better when we work *together*?

**CURTAIN**

**43** What is the main idea of this drama?

- A** Benny's family takes a trip to a science museum.
- B** Benny's family talks about past experiences.
- C** Benny's family learns to enjoy football.
- D** Benny's family helps him with a school assignment.

**44** Choose the event that occurs first.

- F** Benny describes his science project.
- G** Mom says she will pull weeds in the garden.
- H** Mom asks the family to talk about the weekend.
- J** Dad asks the family to watch a football game.

**45** The conflict in the drama results from

- A** Dad wanting to watch a football game.
- B** Mom wanting to make a movie.
- C** Benny needing to do schoolwork.
- D** Chloe attempting to help with the project.

**46** Choose the line that best shows the turning point of the drama.

- F** Whatever you decide, I'm not going to be able to join you.
- G** Wait a minute. Maybe Chloe is on to something.
- H** I remember! They showed the inside of a stomach too.
- J** I'll talk about using my arm and leg muscles.

**47** Choose the statement that best describes the theme of this drama.

- A** Honesty is worth the rewards it may bring.
- B** Teamwork can accomplish more than one person can.
- C** Sometimes the youngest of people have the best ideas.
- D** Families that spend quality time together become lifelong friends.

**48** The author wrote this drama mostly to

- F** entertain readers with a family story.
- G** persuade readers to make family movies.
- H** explain how a family should communicate.
- J** compare different activities a family can do together.

**49** The reader can tell this passage is a drama because it

- A** is told from a first-person point of view.
- B** uses descriptive language.
- C** gives information about a historic event.
- D** has stage directions and dialogue.

**Directions**

The following is a rough draft of a student's letter. It contains mistakes. Read it and answer Numbers 50 through 57.

123 1st Street  
Anytown, TN  
April 9, 2008

Dear Mr. Berners-Lee:

(1) I am writing to you because I recently learned that you are the person that created the World Wide Web. (2) We have been studying modern inventors in school. (3) I believe that of all time you may be one of the most important inventors. (4) Millions of people use your invention every day for they're own purposes. (5) In fact, using the Web has become so common, people cannot imagine life without it. (6) With so many people using it, traffic on the Web is increasing.

(7) I recently used the Web while I was working on a research project about China for school. (8) And using a computer in the school lab, I found all the information I needed for my report. (9) I found pictures of the Great Wall of China and maps of Shanghai and Beijing. (10) I used a computer, not books. (11) I found a way to e-mail a student who lives in China. (12) We even communicated using a Webcam. (13) I, for one, am very grateful to you for inventing this amazingly tool.

(14) I am very interested to know how you came up with the idea of enabling computer users all over the world to communicate with one another. (15) Did you realize, at the time, how important your invention would be? (16) Were you always interested in computers and technology, or were you inspired by another person or experience? (17) I would love to know what your hobbies were when you were younger and do you think those hobbies helped you become an inventor?

(18) Thank you so much for taking the time out of your busy schedule to read my letter. (19) I hope to hear from you soon! (20) My e-mail address is m#tadesse!@intercast.com

Sincerely,

Monica Tadesse

**50** Read Sentence 1.

*I am writing to you because I recently learned that you are the person that created the World Wide Web.*

Choose the correct pronoun to replace the underlined word.

- F** which
- G** whom
- H** whose
- J** who

**51** Read Sentence 3.

*I believe that of all time you may be one of the most important inventors.*

Choose the correct way to rewrite the sentence.

- A** I believe that one of the most important inventors you may be of all time.
- B** I believe that you may be one of all time of the most important inventors.
- C** I believe that you may be one of the most important inventors of all time.
- D** I believe of all time that you may be one of the most important inventors.

**52** Read Sentence 4.

*Millions of people use your invention every day for they're own purposes.*

Choose the correct revision of the underlined word.

- F** their
- G** its
- H** there
- J** it's

*Go On ►*

**53** Read Sentence 5.

*In fact, using the Web has become so common, people cannot imagine life without it.*

Choose the verb or verb phrase that would best replace the underlined words.

- A** became
- B** becomes
- C** has become
- D** will become

**54** Read Sentence 8.

*And using a computer in the school lab, I found all the information I needed for my report.*

Choose the word that should replace the underlined word for a smoother transition.

- F** Since
- G** While
- H** Certainly
- J** Previously



**55** Read Sentences 11 and 12.

*I found a way to e-mail a student who lives in China. We even communicated using a Webcam.*

Choose the best way to combine the sentences.

- A** I found a way to e-mail a student who lives in China, when we even communicated using a Webcam.
- B** Using a Webcam, we even communicated because I found a way to e-mail a student who lives in China.
- C** Finding a way to e-mail a student who lives in China, we even communicated using a Webcam.
- D** I found a way to e-mail a student who lives in China, and we even communicated using a Webcam.

**56** Read Sentence 13.

*I, for one, am very grateful to you for inventing this amazingly tool.*

Choose the best revision for the underlined word.

- F** amaze
- G** amazed
- H** amazing
- J** amazement

**57** Read Sentence 17.

*I would love to know what your hobbies were when you were younger and do you think those hobbies helped you become an inventor?*

Choose the best way to correct the run-on sentence.

- A** I would love to know what your hobbies were when you were younger and whether they helped you become an inventor.
- B** I would love to know what your hobbies were when you were younger, or if you think those hobbies helped you become an inventor.
- C** I would love to know what your hobbies were when you were younger. And do you think those hobbies helped you become an inventor?
- D** I would love to know what your hobbies were when you were younger; and do you think those hobbies helped you become an inventor?

## Just a Little Wrinkle

1 “No, thank you.”

2 Madeleine L’Engle heard those words twenty-six times before she found a publisher to finally accept her novel, *A Wrinkle in Time*. However, the many trials L’Engle faced throughout her childhood had helped to prepare her for such difficulties, and she was not one to give up easily.

3 Madeleine L’Engle was born in New York in 1918. Since her parents were both artists, she developed an appreciation for creativity at a very young age. Much of her childhood was spent reading. She read books over and over again. Once she became bored with the books available to her, she started to invent her own stories.

4 Although she loved reading, school presented many obstacles for L’Engle. She was shy by nature, and she often felt that she didn’t belong with the other students. Since she did not have many friends, she would write stories and hide in her imagination.

5 L’Engle was also extremely quiet around her teachers. Her fifth grade teacher thought that she was not very smart, perhaps because L’Engle preferred to spend her time reading and writing rather than doing her schoolwork. In fact, when L’Engle won a poetry contest at the end of the year, her teacher accused her of cheating. The teacher said, “Madeleine isn’t bright. She couldn’t have written that poem; she must have copied it.” To prove that the poem was not copied, L’Engle’s mother showed the teacher all the poems and stories that the young writer had already written. Needless to say, her teacher was surprised.

6 When L’Engle was twelve, her family moved to Europe, and she was sent to a boarding school where she lived in a dormitory with twelve other girls. She was the only American and not used to being around so many people all of the time. After one year, her parents sent her to a different school in Switzerland. Once again, she was a new student, a foreigner, and extremely timid. As a result, she had a difficult time making friends. Feeling unpopular and being in a strange place, L’Engle naturally turned to her writing.

7 A short time later, L’Engle’s parents moved her to yet another boarding school—the Ashley Hall Boarding School in Charleston, South Carolina. L’Engle had to try to make friends yet again. Although she continued to write, L’Engle started to try new things at Ashley Hall. She acted in plays and edited the literary magazine. By her senior year of high school, L’Engle had friends and no longer felt like the strange, unpopular girl.

8 Throughout her childhood, Madeleine L’Engle faced many trials and obstacles. Rather than be defeated, she found strength in her talent as a writer. Her writing remained a constant. Even though her teacher doubted her, and her peers thought she was odd, L’Engle believed in herself and in her craft.

- 9 After writing *A Wrinkle in Time*, L'Engle would again face rejection, this time from publishers. Time and time again, she would hear that they did not think anyone would want to read her book. She kept trying until she found a publisher that believed in her. The book was published and later won the Newbery Award. It has been reprinted more than sixty times and is now considered a classic. After all of her trials, one can imagine L'Engle responding to all those rejections, "This is just a little wrinkle."



Used by permission of Crosswicks, Ltd. in cooperation with McIntosh & Otis, Inc.

**Madeleine L'Engle 1918 – 2008**

**58** Read this sentence from Paragraph 9.

*It has been reprinted more than sixty times and is now considered a classic.*

In this sentence, classic means

- F** a standard of excellence.
- G** a memory of long ago.
- H** fashionable or stylish.
- J** dull or faded in color.

**59** L'Engle's fifth grade teacher was surprised at L'Engle's poetry because the teacher

- A** had not known about the poetry contest.
- B** had not written any poetry herself.
- C** did not think L'Engle would cheat.
- D** did not know L'Engle could write.

**60** This passage shows that people's personalities affect how

- F** others view them.
- G** families treat them.
- H** much they know.
- J** well they write.

**61** Which sentence from the passage supports the idea that L'Engle learned to overcome rejection?

- A** Although she loved reading, school presented many obstacles for L'Engle.
- B** Feeling unpopular and being in a strange place, L'Engle naturally turned to her writing.
- C** Although she continued to write, L'Engle started to try new things at Ashley Hall.
- D** She kept trying until she found a publisher that believed in her.

**62** Choose the best summary of Paragraph 6.

- F** L'Engle lived with many other girls while at school in Europe.
- G** L'Engle was the only American while at school in Europe.
- H** L'Engle went to two schools in Europe and had trouble making friends.
- J** L'Engle spent time studying in Europe and enjoyed time alone.

*Go On* ►

**63** Why does the author go backward in time after Paragraph 2?

- A to explain why L'Engle became popular
- B to show events that influenced L'Engle
- C to describe what L'Engle learned in school
- D to explain what L'Engle liked to do

**64** Read this sentence from Paragraph 6.

*When L'Engle was twelve, her family moved to Europe, and she was sent to a boarding school where she lived in a dormitory with twelve other girls.*

In this sentence, dormitory means a

- F center for relaxation.
- G room in a castle.
- H residence hall.
- J mountain cabin.

**65** Choose the question that is answered in the passage.

- A When did L'Engle begin writing?
- B Which books did L'Engle enjoy reading in school?
- C Which author inspired L'Engle to become a writer?
- D What award did L'Engle's book win?

**Directions**

Read the poem. Then answer Numbers 66 through 70.

## Decisions, Decisions

Sometimes late at night,  
All snug in my bed,  
Thoughts of my childhood  
Parade through my head.

- 5 I think back to simpler times,  
No large decisions to make.  
Just play time and games,  
With afternoon naps to take . . .

- I'd play all day and  
10 Sleep when told,  
Sometimes wishing  
I'd quickly grow old.

- Growing older, growing choices,  
Each minute, every second.  
15 Requires many more decisions  
Than I ever reckoned.<sup>1</sup>

- What to do? Where to go?  
To save or to buy?  
All the decisions now required  
20 Make me shiver and sigh.

Childish choices I choose  
Childish consequences I get  
Won't someone come  
And rescue me yet?

- 25 If growing older means making  
Even more choices still,  
I'd rather stay young  
Forever, I will!

<sup>1</sup>reckoned: thought



Go On ►

**66** Read Line 3.

*Thoughts of my childhood*

What does childhood mean as it is used in the line above?

- F** able to be a child
- G** similar to a child
- H** state of being a child
- J** a person who is a child

**67** Read this stanza from “Decisions, Decisions.”

*What to do? Where to go?  
To save or to buy?  
All the decisions now required  
Make me shiver and sigh.*

Which lines in the stanza rhyme?

- A** Lines 1 and 2
- B** Lines 2 and 4
- C** Lines 2 and 3
- D** Lines 1 and 4

**68** The conflict in “Decisions, Decisions” can best be described as

- F** person vs. self.
- G** person vs. person.
- H** person vs. technology.
- J** person vs. environment.



**69** “Decisions, Decisions” is best described as a poem because it

- A** asks many questions.
- B** develops a strong plot.
- C** describes a topic using verses.
- D** tells about the life of a person.

**70** Read Line 21 from the poem.

*Childish choices I choose*

Which sound device is used in this line?

- F** accent
- G** alliteration
- H** repetition
- J** onomatopoeia

*Go On* ►

**Directions**

Read the paragraph. Then answer Numbers 71 through 75.

The Chesapeake Bay Bridge-Tunnel is located in Chesapeake Bay, Virginia. It's an amazing sight to see. Not only does it cross over the water, it tunnels under the water as well. The bridge-tunnel is more than twenty miles long, and about twenty million vehicles travel on it each year. The wind is sometimes strong on the bridge. Construction on the Chesapeake Bay Bridge-Tunnel began in 1960, and it took nearly four years to complete.

**71** Which sentence, if added, would best support ideas presented in the paragraph?

- A** Many bridges and tunnels are used in America every day.
- B** The Lesner Bridge is also known as Highway 60.
- C** The bridge-tunnel connects Virginia Beach to Virginia's eastern shore.
- D** The Brunswick Bridge connects Maryland and Virginia.

**72** Which sentence does not belong in this paragraph?

- F** The Chesapeake Bay Bridge-Tunnel is located in Chesapeake Bay, Virginia.
- G** It's an amazing sight to see.
- H** Not only does it cross over the water, it tunnels under the water as well.
- J** The wind is sometimes strong on the bridge.

**73** Which sentence would be the best conclusion for this paragraph?

- A** Virginia is on the eastern seaboard.
- B** Virginia has five covered bridges that are open to the public.
- C** The bridge-tunnel continues to be an engineering marvel.
- D** Other Virginia bridges are the James River Bridge and the Boulevard Bridge.

**74** The next paragraph should contain information about

- F** what drivers should know when traveling across bridges in Virginia.
- G** how the Chesapeake Bay Bridge-Tunnel was constructed.
- H** the types of vehicles permitted on the Chesapeake Bay Bridge-Tunnel.
- J** some of the other bridges in Virginia.

**75** Choose the best title for the paragraph.

- A** Bridging the Gap
- B** One Unique Bridge
- C** Constructing Bridges
- D** Bridges in Virginia

**Directions** Read and answer Numbers 76 through 83.

**76** Read the sentence.

\_\_\_\_\_! *The oven door is hot, and I wouldn't want you to burn yourself on it.*

Choose the interjection that best completes the sentence.

- F** Oh, no
- G** Look out
- H** Calm down
- J** Way to go

**77** Read the paragraph.

*The Mississippi River is the second largest river in the United States. Only the Missouri River is larger. The Mississippi River flows from Minnesota to the Gulf of Mexico. The river supports many species of freshwater fish, birds, deer, raccoons, and other mammals. It also supports a variety of trees. The flow of the Mississippi is much slower than the Amazon River.*

Choose the sentence that contains irrelevant information and should be deleted from the paragraph.

- A** The Mississippi River is the second largest river in the United States.
- B** The Mississippi River flows from Minnesota to the Gulf of Mexico.
- C** The river supports many species of freshwater fish, birds, deer, raccoons, and other mammals.
- D** The flow of the Mississippi is much slower than the Amazon River.

**78** Marisol's history class is doing group projects. Marisol has been assigned as the group's leader. When several of her group members begin arguing over the details of the project, Marisol must make a decision. What could Marisol do that would best keep her group on task and able to complete the assigned work?

- F** Marisol could remind the group members that they only have a short period of time in which to complete the assigned task, and then she could work independently if others do not begin helping.
- G** Marisol could gather the group together to go over the task the group needs to complete, and then she could assign jobs to individuals in the group.
- H** Marisol could take notes about the different opinions being expressed by group members, and then she could choose the best idea and suggest that the group complete the task using it.
- J** Marisol could talk to her teacher about changing jobs within her group so she will not have to interfere in the discussions taking place.

**79** Which member of a group is most responsible for making sure every member's opinion is written down for evaluation during a brainstorming task?

- A** the leader
- B** the timekeeper
- C** the recorder
- D** the information gatherer

**80** Read these two sentences.

*There are several reasons I do not want to go to the movie theater with James.  
\_\_\_\_\_, I am saving my money for new in-line skates and a helmet.*

Which word or phrase best joins the two sentences?

- F** For example
- G** As a result
- H** However
- J** Similarly

**81** Carmen is planning a summer vacation. What steps should she take to make sure necessary arrangements are made for her absence at work?

- A** Carmen should write a letter to her boss requesting time off, and then she should send an e-mail to her coworkers letting them know the details of her vacation.
- B** Carmen should write a report of the work she has completed during the year, and she should e-mail the report to her boss before she leaves on vacation.
- C** Carmen should send an e-mail to her coworkers letting them know that she is planning to be out of the office for several days in the summer, and then Carmen should leave directions with her boss of where she will be traveling.
- D** Carmen should send an e-mail to her boss requesting time off for the days she will be out of the office and prepare a list of instructions for the person who will take over her workload while she is away.

**82** Marco is writing a report about Abraham Lincoln. He wants to use primary sources and secondary sources for his research. Which of these is a secondary source?

- F** a diary written by Abraham Lincoln
- G** a letter from Abraham Lincoln to his wife
- H** a speech about Abraham Lincoln
- J** an autobiography of Abraham Lincoln

**83** Brett knows that John Hancock was one of the signers of the Declaration of Independence, but he would like to learn more about him. Which is a primary source that would give him the most accurate information?

- A** an article about John Hancock found on the Internet
- B** a series of letters to John Hancock from his wife
- C** an online encyclopedia entry about John Hancock
- D** a published diary written by John Hancock

**DO NOT  
MARK  
ON THIS  
PAGE**



# Mathematics

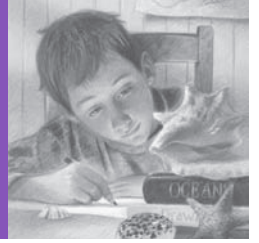

## Part 1

**1** Roberto is making cookies using a recipe. He will use  $\frac{1}{2}$  of every measurement listed in the recipe. If the recipe requires  $\frac{3}{4}$  cup of water, how much water should Roberto use?

- A**  $\frac{3}{2}$  cups
- B**  $\frac{2}{3}$  cup
- C**  $\frac{1}{2}$  cup
- D**  $\frac{3}{8}$  cup

*Go On* ►

- 2** The lengths of 4 cars are displayed on the graph.

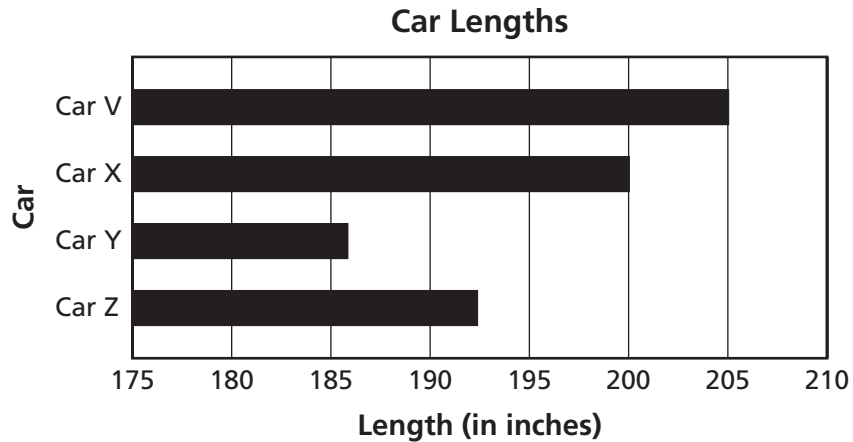

Which feature of the graph may be misleading?

- F** The scale does not start at zero.
- G** The values on the horizontal axis increase by 5.
- H** The bars are horizontal instead of vertical.
- J** The bars are not in order from longest to shortest.

- 3** Fernando's grandparents gave him and his 2 sisters \$42.75 to share equally. What is the total amount of money that Fernando should receive?

- A** \$10.95
- B** \$14.25
- C** \$21.37
- D** \$85.50

- 4** Look at the key below.

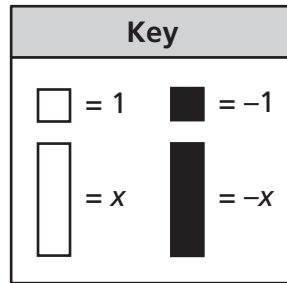

Which expression is represented by this model?



- F**  $-2x + 4$
- G**  $-4x + 2$
- H**  $-4x + (-2)$
- J**  $-2x + (-4)$

- 5** Which equation represents the distributive property?

- A**  $6 \times (4 + 8) = (6 \times 4) + (6 \times 8)$
- B**  $6 + (4 + 8) = (6 + 4) + 8$
- C**  $6 + (4 + 8) = (4 + 8) + 6$
- D**  $6 \times (4 \times 8) = (6 \times 4) \times 8$

**6** The floor area of Ms. Hernandez's classroom is 900 square feet. A reading center uses 108 square feet of the classroom floor area. What percent of the classroom floor area is used as the reading center?

**F** 8%

**G** 12%

**H** 80%

**J** 90%

**7** Danielle had \$33.58. She spent \$19.99 of this money on art supplies. How much money should Danielle have left?

**A** \$53.57

**B** \$26.41

**C** \$14.58

**D** \$13.59

8

Which number line shows Point  $P$  located closest to 5.5?

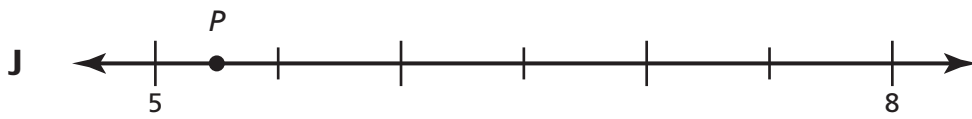
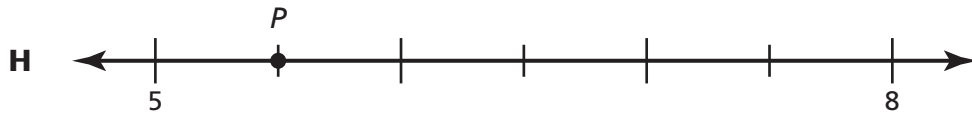
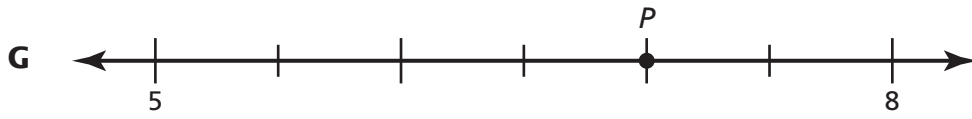
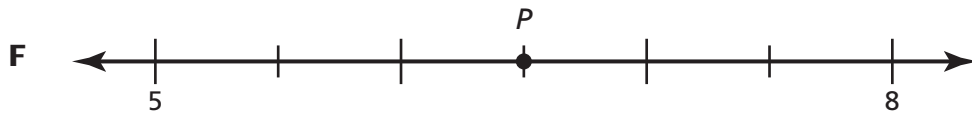

- 9** The results of a morning voting session of 200 students are shown in the table.

**Mascot Votes**

Animal	Number of Votes
Bulldog	50
Cougar	25
Eagle	10
Mustang	100
Ram	15

Based on the results in the table, how many more votes will be expected for a bulldog mascot if 300 more students vote in the afternoon?

- A** 75
- B** 125
- C** 150
- D** 250

- 10** The table below shows the amount of money Julia earned and spent in a four-day period.

**Money Julia Earned and Spent**

Day	Activity	Amount
Monday	Earned for washing cars	\$68
Tuesday	Spent on cleaning supplies	\$36
Wednesday	Earned for washing windows	\$75
Thursday	Spent on new clothes	\$28

Which integer best represents the amount of money Julia spent on Tuesday?

- F** -36
- G** -28
- H** 28
- J** 36

- 11** This graph shows the number of different types of pets owned by students in a class.

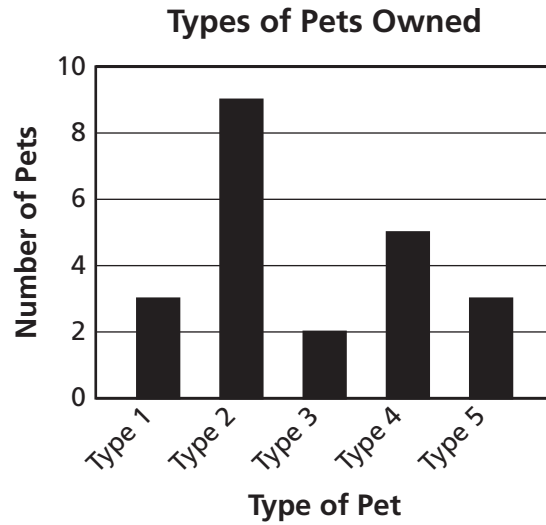

Bianca says that about twice as many dogs as cats are owned by students in this class. What feature of this graph may be misleading?

- A** The vertical scale shows only even numbers.
- B** The bars are not arranged from longest to shortest.
- C** The horizontal axis does not identify the types of pets owned.
- D** The label on the vertical axis does not include the unit used.



- 12** Ahmad set a goal to study for 15 hours this week. On Monday, he studied for  $1\frac{1}{2}$  hours. He studied for  $2\frac{3}{4}$  hours on Tuesday and  $\frac{1}{2}$  hour on Wednesday. How many hours will Ahmad have to study during the rest of the week to meet his goal?

**F**  $4\frac{3}{4}$

**G**  $9\frac{1}{2}$

**H**  $10\frac{1}{4}$

**J**  $11\frac{3}{4}$

- 13** The dimensions of a block of wood shaped like a rectangular prism are shown below.

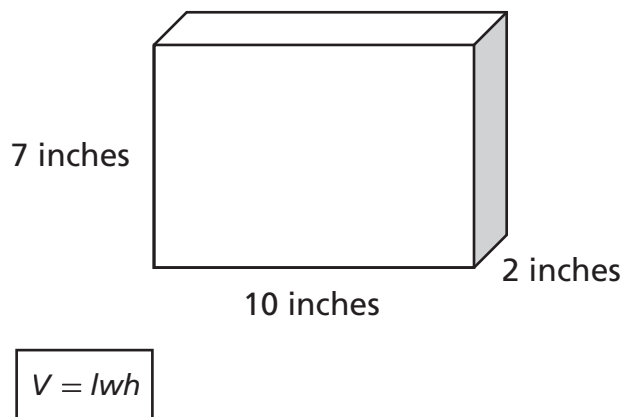

What is the volume of the block of wood?

- A** 208 cubic inches  
**B** 140 cubic inches  
**C** 90 cubic inches  
**D** 70 cubic inches

Go On ►

- 14** The circle below has a diameter of 56 centimeters (cm).

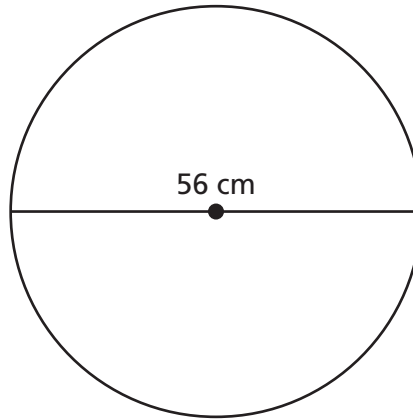

$$A = \pi r^2$$
$$\pi \approx 3.14$$

Which is closest to the area of the circle?

- F** 87.92 cm<sup>2</sup>
- G** 175.84 cm<sup>2</sup>
- H** 2,461.76 cm<sup>2</sup>
- J** 9,847.04 cm<sup>2</sup>

- 15** Which point is located at  $(1, -5)$  on the grid below?

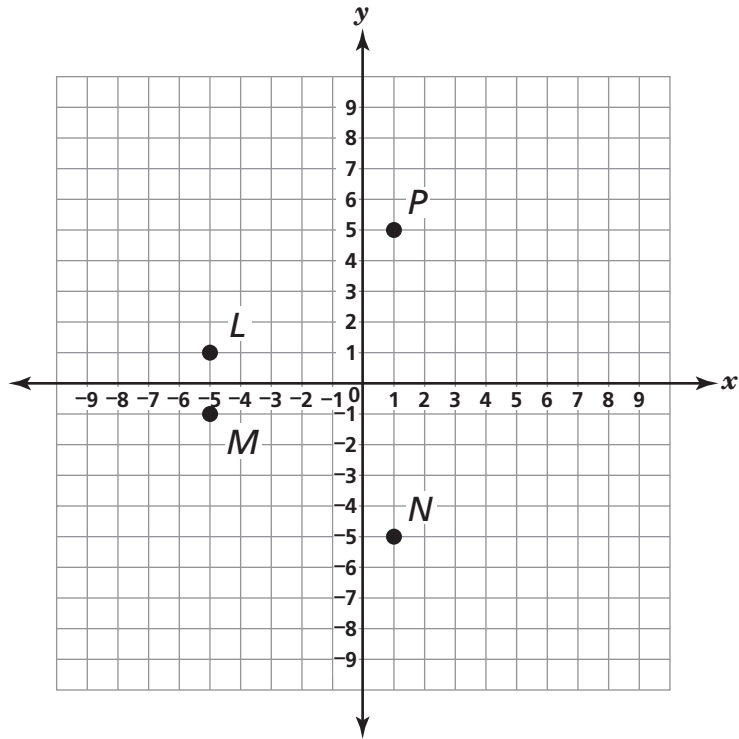

- A** Point *L*
- B** Point *M*
- C** Point *N*
- D** Point *P*
- 
- 16** A store sold 255 DVDs in 5 days. If sales continue at the same rate, which is the best prediction of the number of DVDs the store could expect to sell in 30 days?
- F** 7,650
- G** 6,000
- H** 1,500
- J** 1,000

**17** Solve:  $\frac{4}{5} \times \frac{3}{8} =$

**A**  $2\frac{2}{15}$

**B**  $1\frac{7}{40}$

**C**  $\frac{2}{5}$

**D**  $\frac{3}{10}$

**18** Trevor ran 97 miles during 5 days of practice for a cross-country race. He ran about the same number of miles each day. Which is the best estimate of the number of miles Trevor ran each day?

**F** 20

**G** 25

**H** 105

**J** 500

**19** Mr. Kincaid has a piece of pipe that is 3.08 meters long. Which length is equivalent to 3.08 meters?

**A**  $3\frac{2}{25}$  meters

**B**  $3\frac{4}{25}$  meters

**C**  $3\frac{1}{5}$  meters

**D**  $3\frac{4}{5}$  meters

**20** Which number line shows Point *P* located closest to  $-15$ ?

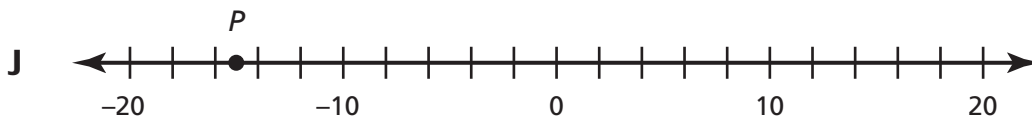
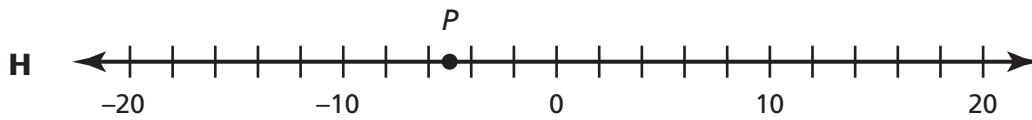
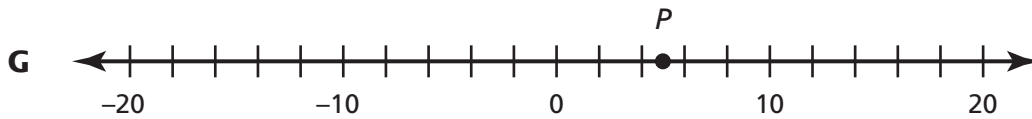
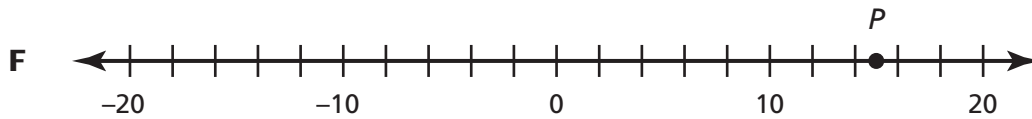

Go On ►

- 21** The table below shows the number of pumpkins sold at a pumpkin patch.

**Pumpkins Sold**

Size	Number of Pumpkins	Price
Large	100	\$8
Small	$y$	\$5

A total of \$1,050 was made on the sales of large and small pumpkins. Which equation could be used to find  $y$ , the number of small pumpkins that were sold?

- A**  $5y + 8(100) = 1,050$
- B**  $5y = 8(100) + 1,050$
- C**  $5y + 1,050 = 8(100)$
- D**  $5y + (8 + 100) = 1,050$

- 22** Which expression is equivalent to  $4(m + 8) + 5m$ ?

- F**  $17m$
- G**  $41m$
- H**  $9m + 8$
- J**  $9m + 32$

**23** What value of  $y$  makes the equation  $3y + 9 = 36$  true?

- A** 9
- B** 15
- C** 30
- D** 81

**24** Which expression means the same as “9 less than the sum of 10 and 6 times a number  $n$ ”?

- F**  $9 - (6n \times 10)$
- G**  $(6n - 10) - 9$
- H**  $9 - (6n + 10)$
- J**  $(6n + 10) - 9$

- 25** The circumference of the tire shown below is 72.22 centimeters (cm).

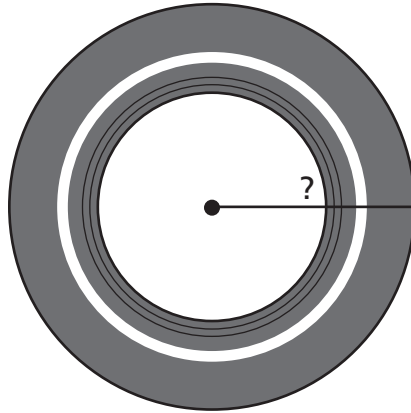

$$\pi \approx 3.14$$

$$C = 2\pi r$$

Which is closest to the radius of the tire?

- A** 4.8 cm
- B** 9.6 cm
- C** 11.5 cm
- D** 23.0 cm



- 26** Raul painted each surface of the cylinder-shaped container shown below.

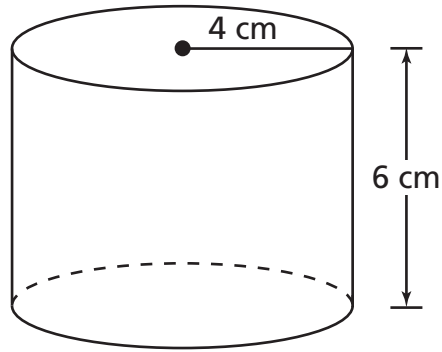

$$SA = 2\pi r^2 + 2\pi rh$$

What is the total surface area that Raul painted, in terms of  $\pi$ ?

- F**  $80\pi \text{ cm}^2$
- G**  $48\pi \text{ cm}^2$
- H**  $40\pi \text{ cm}^2$
- J**  $32\pi \text{ cm}^2$

**27** Pilar had 6 rows in her garden for planting flowers. She planted daisies in  $4\frac{3}{5}$  of the rows.

Which improper fraction is equivalent to  $4\frac{3}{5}$ ?

**A**  $\frac{17}{3}$

**B**  $\frac{17}{5}$

**C**  $\frac{23}{3}$

**D**  $\frac{23}{5}$

**28** Look at the figure shown below.

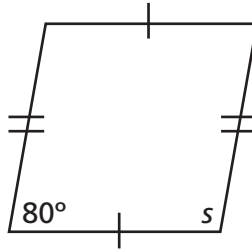

What is the value of  $s$ ?

- F**  $10^\circ$
- G**  $20^\circ$
- H**  $100^\circ$
- J**  $200^\circ$

## Part 2

**29** Which number line shows Point  $R$  located closest to 2.85?

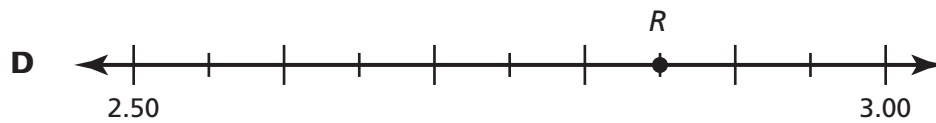
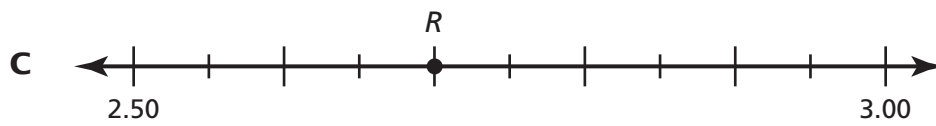
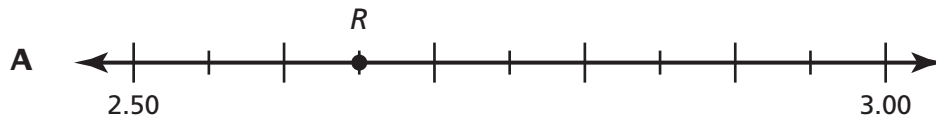

**30** Look at the key below.

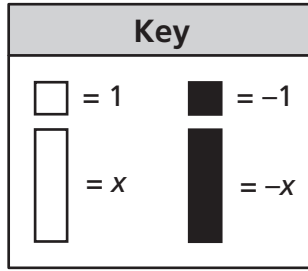

Which expression is represented by this model?



- F**  $-3x - 5$
- G**  $-3x + 5$
- H**  $-5x - 3$
- J**  $-5x + 3$

**31** Isabella wrote the equation below.

$$34 = 6 + 4c$$

What value of  $c$  makes the equation true?

- A** 160
- B** 112
- C** 10
- D** 7

Go On ►

- 32** The measures of two of the exterior angles of a triangle are shown below.

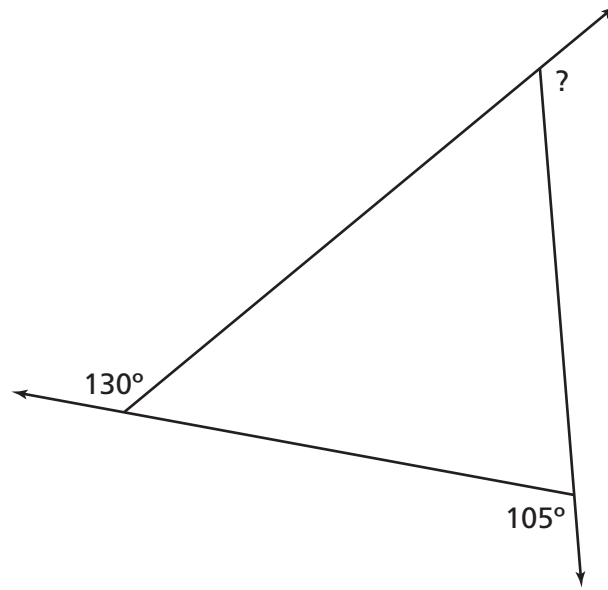

What is the measure of the third exterior angle?

- F**  $235^\circ$
- G**  $125^\circ$
- H**  $75^\circ$
- J**  $55^\circ$

**33** The list below shows the amount of time it will take Tammy to do each of her chores.

- Rake the leaves (20 minutes)
- Clean her room (40 minutes)
- Do the laundry (40 minutes)
- Do her homework (40 minutes)

Which equation could be used to find  $m$ , the total number of minutes it will take Tammy to do all the chores on her list?

- A**  $m = (40 + 3) \times 20$
- B**  $m = (40 \times 3) \times 20$
- C**  $m = (40 + 3) + 20$
- D**  $m = (40 \times 3) + 20$

**34** Which situation is best represented by the integer  $-12$ ?

- F** The length of curtains is increased by 12 inches.
- G** The price of a scooter is reduced by 12 dollars.
- H** The size of a picture is enlarged by 12 percent.
- J** The temperature rises by 12 degrees.

**35** Richard has 3 whole pizzas. He will divide these pizzas so that each person receives  $\frac{2}{8}$  of a pizza. What is the greatest number of people who can receive  $\frac{2}{8}$  of a pizza?

- A** 4
- B** 6
- C** 12
- D** 16

**36** Which expression has the same value as  $54 - (10 + 18)$ ?

- F**  $54 - 18 + 10$
- G**  $54 - (18 + 10)$
- H**  $(54 + 10) - 18$
- J**  $(54 - 18) + 10$



- 37** The amount of sales in dollars for a company in the first 3 years is shown on the graph.

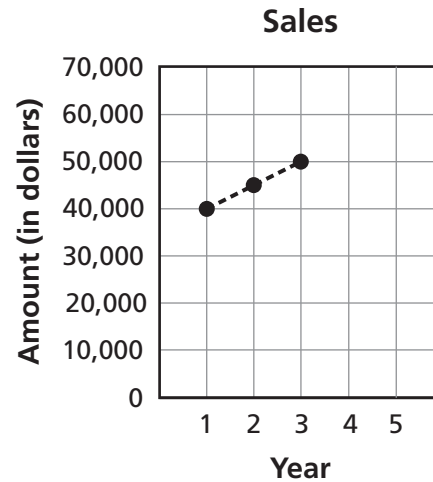

If sales continue to increase as shown, which is the best prediction of the amount the company will have in sales in Years 4 and 5 combined?

- A** less than \$50,000
- B** between \$50,000 and \$60,000
- C** between \$110,000 and \$120,000
- D** more than \$120,000

- 38** Which point on the number line below is closest to  $14\frac{7}{12}$ ?



- F** Point *P*
- G** Point *Q*
- H** Point *R*
- J** Point *S*

*Go On* ►

**39** A newspaper company wants to find out whether people prefer to get their newspapers delivered to their mailboxes or to their front doors. To help get this information, the company will call 200 randomly selected people from the city where the newspapers are delivered and ask them to select their preferred delivery method. Which best explains how to make sure the sample is not biased?

- A** First ask the people how often they read the newspaper.
- B** First ask the people if they are newspaper delivery customers.
- C** First ask the people which section of the newspaper is their favorite.
- D** First ask the people if they plan to continue living in the city for at least a year.

**40** On Saturday, Alma made 70% of the sales at a store where she works. The total amount of sales at the store on Saturday was \$910. What was Alma's total amount of sales on Saturday?

- F** \$130
- G** \$273
- H** \$637
- J** \$840

**41** Shaneé needs to translate the description below into a math equation.

8 more than twice a number  $y$  is the same as the product of 4 and 3

Which equation is a correct translation of the description?

- A**  $8 + 2y = 4 \times 3$
- B**  $8 + 2y = 4 + 3$
- C**  $2y - 8 = 4 \times 3$
- D**  $2y - 8 = 4 + 3$

**42**

The midday temperatures in a city for Monday and Tuesday are represented by points on the number line below.

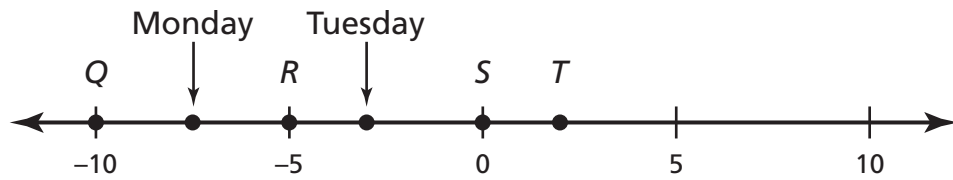

The midday temperature on Wednesday was 2 degrees lower than the midday temperature on Tuesday. Which point best represents the midday temperature on Wednesday?

- F** Point *Q*
- G** Point *R*
- H** Point *S*
- J** Point *T*

*Go On* ►

43

The graph shows the number of different types of lawn mowers sold at a garden center in different years.

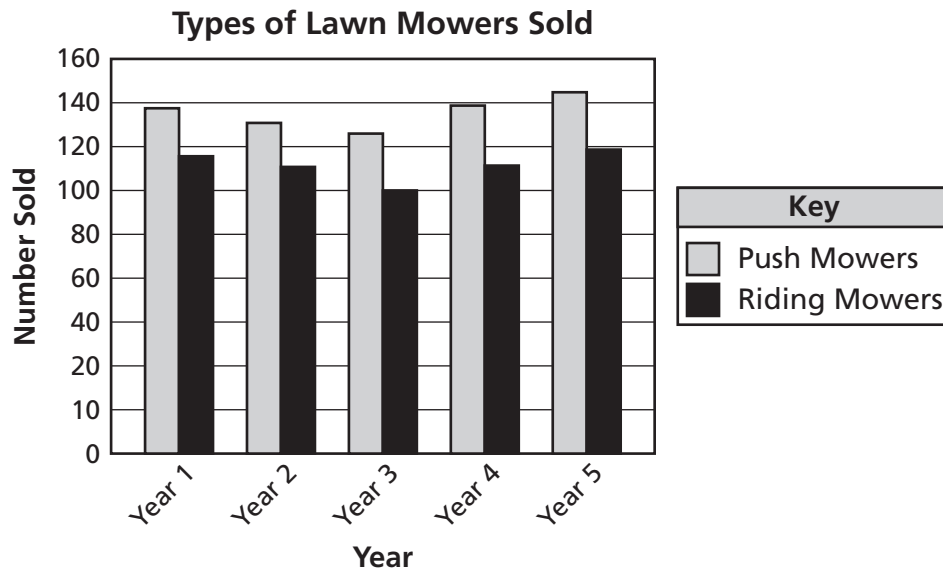

Which feature of this graph may be misleading?

- A** The bars are different heights.
- B** The scale on the vertical axis is not consistent.
- C** The labels on the horizontal axis do not show the actual year.
- D** The information in the key does not match the information on the graph.

**44** A house-painting company has  $8\frac{1}{4}$  gallons of paint available to paint a house. The paint will be divided equally among 3 painters. How many gallons of paint will each painter receive?

**F**  $2\frac{3}{4}$  gallons

**G**  $5\frac{1}{4}$  gallons

**H**  $11\frac{1}{4}$  gallons

**J**  $24\frac{3}{4}$  gallons

- 45** Roberto swung a rope with a ball tied to the end of it in a circle, as shown below.

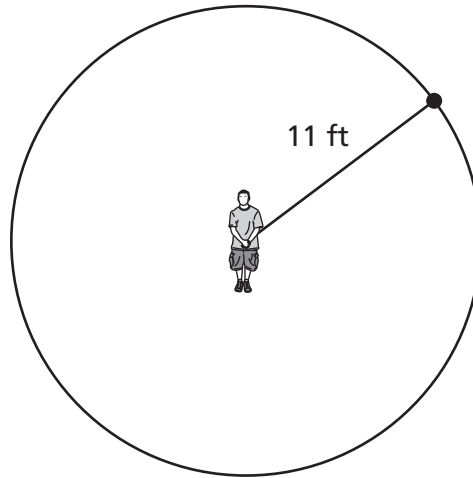

$$A = \pi r^2$$
$$\pi \approx 3.14$$

Which is closest to the area of the circle that Roberto made when he swung the rope?

- A** 1,519.76 ft<sup>2</sup>
- B** 379.94 ft<sup>2</sup>
- C** 69.08 ft<sup>2</sup>
- D** 34.54 ft<sup>2</sup>

**46** Which point is located at  $(6, -4)$  on the grid below?

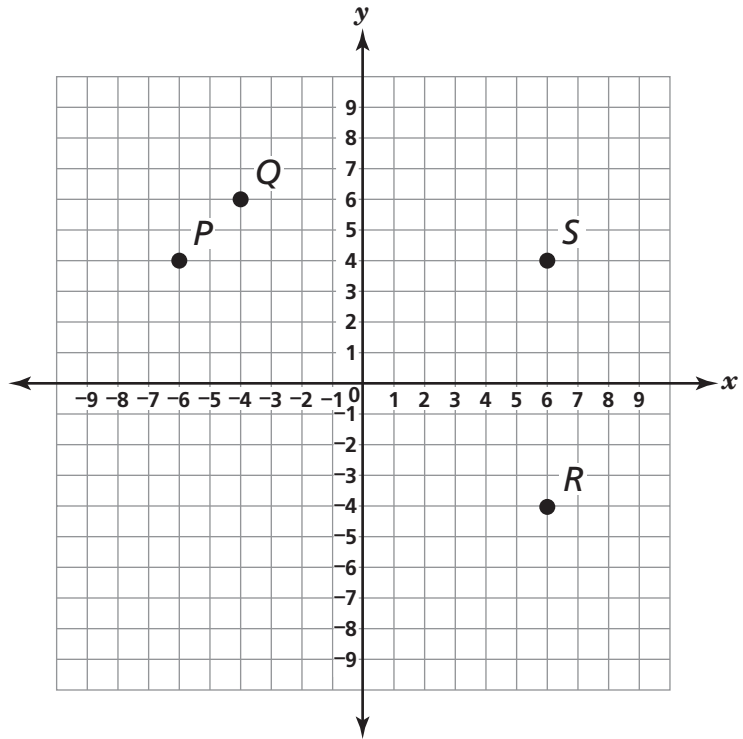

- F** Point *P*
- G** Point *Q*
- H** Point *R*
- J** Point *S*

*Go On* ►

**47** Paola is making batches of spaghetti sauce for a dinner at school. Her recipe uses  $1\frac{2}{3}$  pounds of ground meat for each batch of sauce. She started with 27 pounds of ground meat and has already made 3 batches of the sauce. How many more batches of sauce should she be able to make?

- A** 13
- B** 16
- C** 22
- D** 24

**48** Which equation represents the commutative property?

- F**  $(7 + 3) + 8 = 7 + (3 + 8)$
- G**  $5(2 + 3) = (5 \times 2) + (5 \times 3)$
- H**  $3 \times 5 = 5 + 5 + 5$
- J**  $(7 + 3) + 5 = 5 + (7 + 3)$

**49** Which percent is equivalent to  $\frac{8}{10}$ ?

- A** 125%
- B** 80%
- C** 45%
- D** 20%



**50** There are 20 students in 4 plays in Mr. Stewart's class, and there are 24 students in 3 plays in Mrs. Rodriguez's class. Based on this information, which statement is true?

- F** The ratio of students in Mr. Stewart's class in plays to students in Mrs. Rodriguez's class in plays is 6:5.
- G** The ratio of students to plays is 5:1 in Mr. Stewart's class and 8:1 in Mrs. Rodriguez's class.
- H** The ratio of students to plays is 1:5 in Mr. Stewart's class and 1:8 in Mrs. Rodriguez's class.
- J** The ratio of plays in Mr. Stewart's class to plays in Mrs. Rodriguez's class is 3:4.

**51** A total of 130 letters and 30 packages was mailed at a post office on Saturday. The cost for each letter was between \$0.42 and \$0.68, and the cost for each package was between \$5.55 and \$6.30. Which best represents the total cost for the letters and packages mailed on Saturday?

- A** more than \$300
- B** between \$200 and \$300
- C** between \$100 and \$200
- D** less than \$100

**52** The bar graph shows the number of people on a city bus at different times of the day.

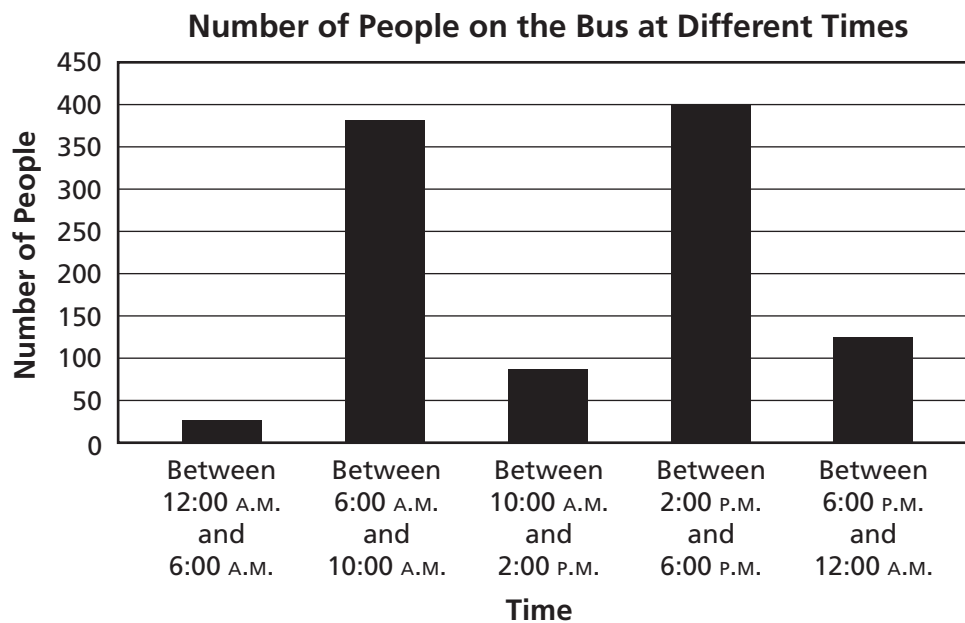

Which feature of this bar graph may be misleading?

- F** The increments on the vertical axis are increasing by 50.
- G** The bars are not in order from largest to smallest.
- H** The scale on the vertical axis is not consistent.
- J** The time increments are not consistent.

**53** The librarian had 64 books to deliver to teachers. She delivered 7 of the books and then divided the rest of the books equally into 3 boxes. Which equation could be used to find  $n$ , the total number of books she put into each box?

**A**  $n = 64 - (7 \times 3)$

**B**  $n = (64 - 7) \div 3$

**C**  $n = 64 + (7 \times 3)$

**D**  $n = (64 + 7) \div 3$

**54** A town mayor wants to know if the residents of a town are in favor of building a new football stadium. On Saturday, he randomly surveyed 50 male residents of the town to see if they were in favor of the new stadium. Which sentence best explains why this sample may be biased?

**F** The sample was taken on only one day.

**G** The sample included only males in the survey.

**H** The sample included residents of only one town.

**J** The sample did not include all the males in the town.

**55** Between noon and 10:00 P.M., Tyrone recorded  $-18^\circ\text{F}$  as the change in temperature. Which best describes the change in temperature?

**A** The temperature decreased  $18^\circ\text{F}$  by 10:00 P.M.

**B** The temperature increased  $18^\circ\text{F}$  by 10:00 P.M.

**C** The temperature was  $-18^\circ\text{F}$  at 10:00 P.M.

**D** The temperature was  $18^\circ\text{F}$  at 10:00 P.M.

**STOP** 

**DO NOT  
MARK  
ON THIS  
PAGE**



**1** A food chain is shown below.

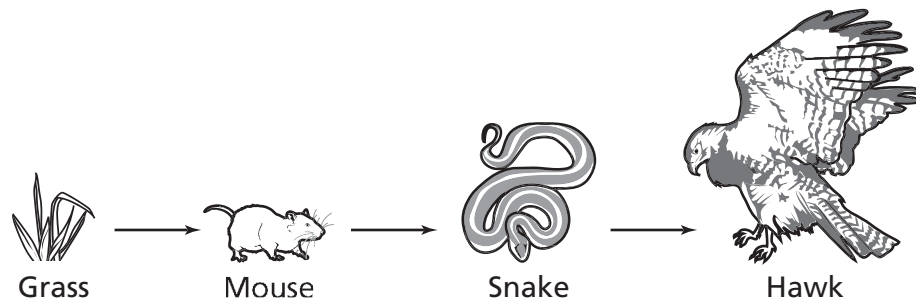

Which organism in the food chain is a producer?

- A** Grass
- B** Mouse
- C** Snake
- D** Hawk

**2** Wind is considered a renewable resource because the energy that drives the wind originally comes from

- F** the sun.
- G** rain.
- H** the ocean.
- J** oxygen.

**3** The length of time it takes Earth to rotate once on its axis is called a

- A** season.
- B** month.
- C** year.
- D** day.

**4** Which hot and dry biome is home to large herds of herbivores that feed on the many kinds of grasses?

- F** tundra
- G** desert
- H** rain forest
- J** savannah

**5** The diagram shows the sun and Earth.

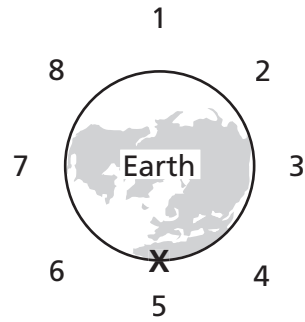
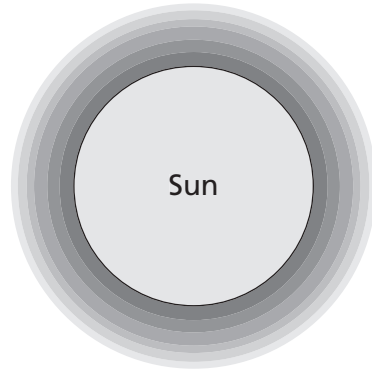

What will cause a high tide to occur at location X?

- A** The moon is at location 2.
- B** The moon is at location 4.
- C** The moon is at location 5.
- D** The moon is at location 7.

**6** Which set of objects best conducts electricity?

- F** an iron washer and a metal fork
- G** a door key and a rubber ball
- H** a copper pipe and a wooden spoon
- J** a rubber mallet and a glass measuring cup

*Go On* ►

**7** The diagram shows Earth at four different locations around the sun.

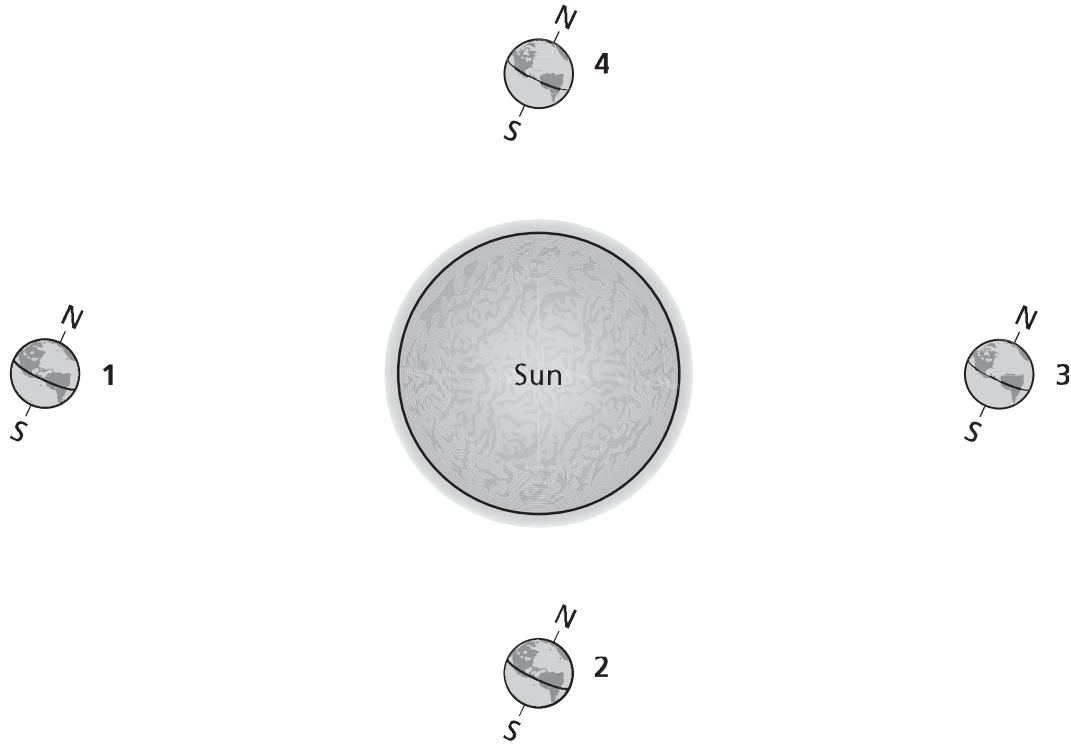

At which location is it summer in Earth's Northern Hemisphere?

- A** 1
- B** 2
- C** 3
- D** 4



**8** In a biotic response experiment, two plants with the same mass are placed in identical pots. Both plants are given the same amount of water, soil, and sunlight. After one week, the test plant is given one tablespoon of liquid fertilizer. Two weeks later, the data shows the test plant has the greater mass. What is the independent variable in this biotic response experiment?

- F** amount of sunlight
- G** soil temperature
- H** liquid fertilizer
- J** size of the pot

**9** Which is a biotic factor of an alpine forest?

- A** elk
- B** rainfall
- C** soil
- D** mountains

**10** A solar eclipse is most likely to occur when Earth, the moon, and the sun are in which location?

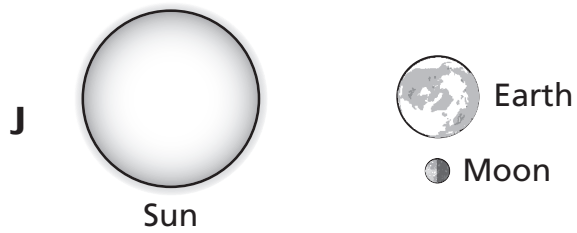
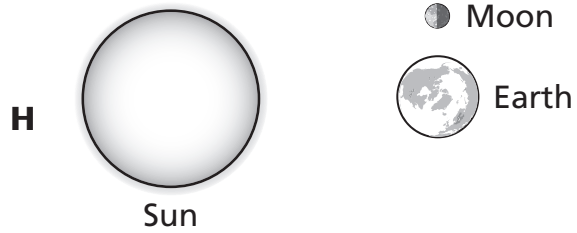
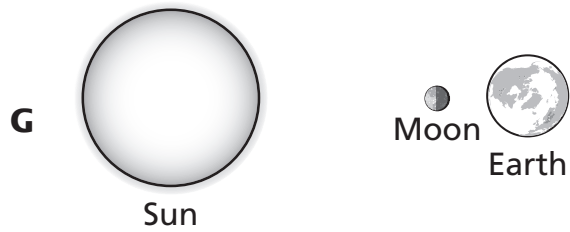
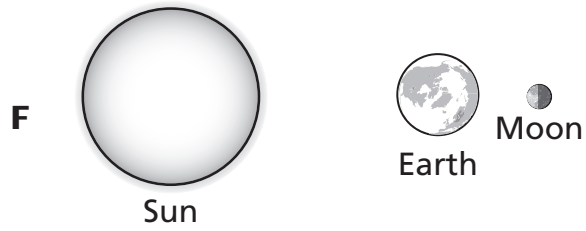

**11** Early satellites were used to monitor weather. In which other area have satellites most benefitted humans?

- A** medicine
- B** navigation
- C** fossil exploration
- D** recycled materials

**12** The diagram below shows a simple electrical circuit.

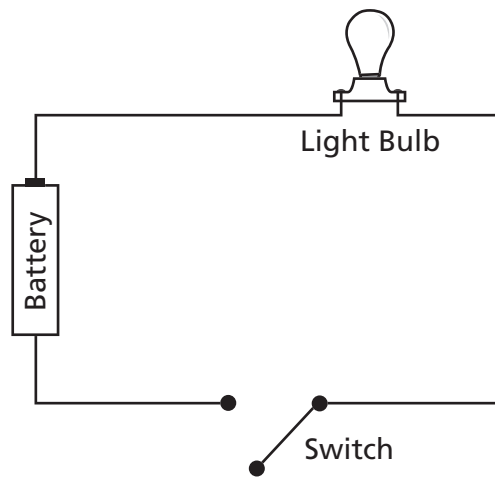

What energy conversions occur when the switch is closed?

- F** chemical energy  $\rightarrow$  electrical energy  $\rightarrow$  light energy
- G** light energy  $\rightarrow$  electrical energy  $\rightarrow$  thermal energy
- H** thermal energy  $\rightarrow$  electrical energy  $\rightarrow$  light energy
- J** light energy  $\rightarrow$  chemical energy  $\rightarrow$  electrical energy

**13** Which occurs when the moon, the sun, and Earth are in a straight line?

- A** first quarter moon
- B** third quarter moon
- C** neap tide
- D** spring tide

**14** How is soil fertility in a deciduous forest dependent on the trees?

- F** Fallen leaves decay and make the soil rich with organic matter.
- G** The trees shade the ground so small amounts of light get through to the soil.
- H** Tree roots keep rocks from breaking and adding minerals to the soil.
- J** Large rocks help break down smaller rocks and pebbles in forming soil.

15

The Gulf Stream is a warm water current that begins in the Gulf of Mexico. A diagram of the Gulf Stream is shown below.

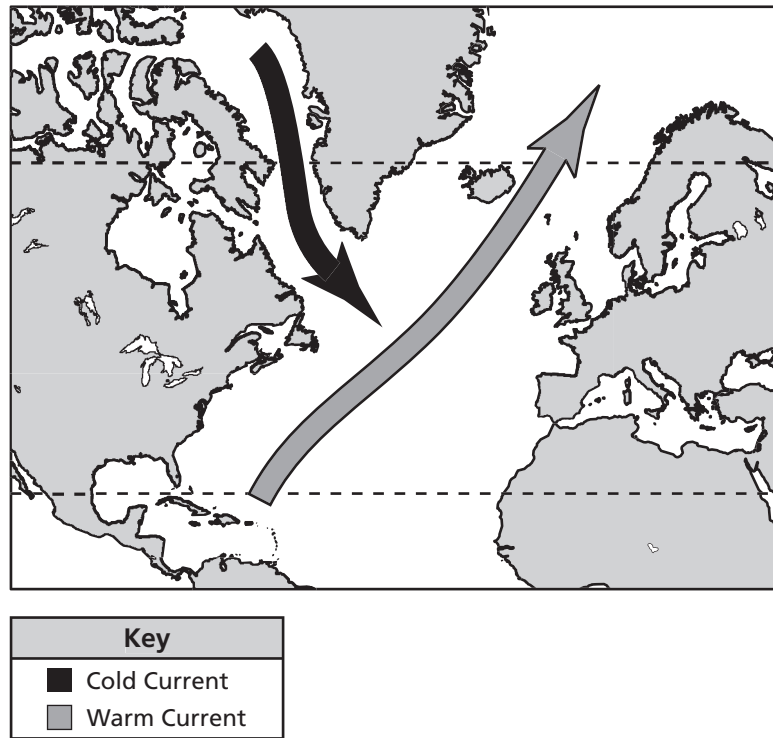

Which best describes the movement of the Gulf Stream?

- A Cold currents carry cold water from the polar zones toward the equator.
- B Warm currents carry warm water from the tropics toward the poles.
- C Warm currents carry cold water from the tropics toward the poles.
- D Cold currents carry warm water from the polar zones toward the equator.

**16** The following is a process that takes place in the atmosphere.

solar energy → warm air rises → air cools in upper atmosphere and sinks → air currents

This process can best be identified as

- F** wind formation.
- G** cloud formation.
- H** precipitation runoff.
- J** static electricity.

**17** Which simple circuit most likely produces heat and light energy?

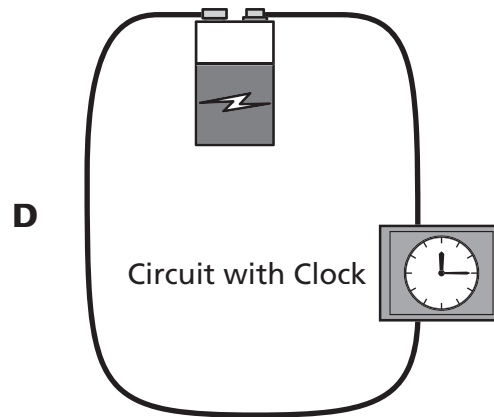
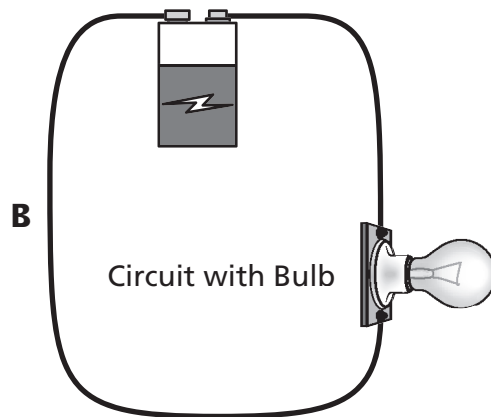
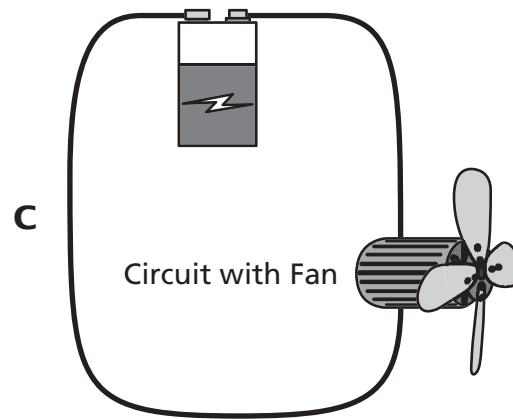
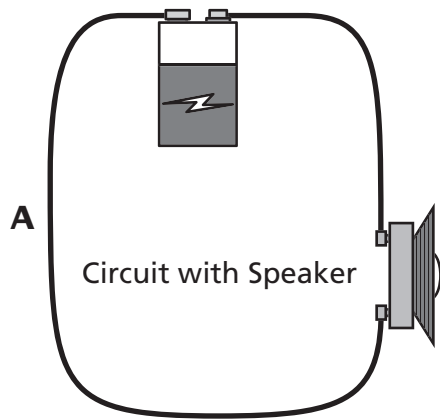

**18** The diagram shows a waning crescent moon.

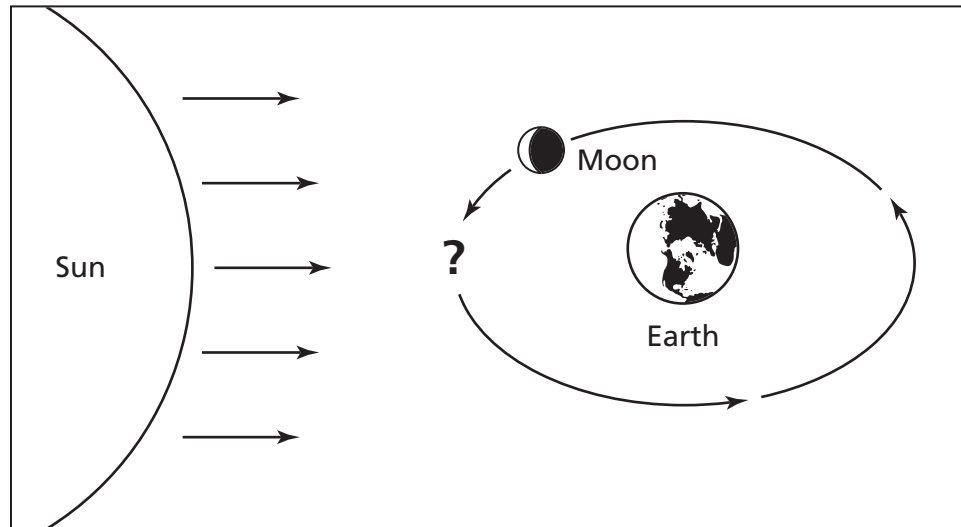

Which moon phase will happen next?

- F** new moon
- G** waning gibbous
- H** full moon
- J** last quarter

*Go On* ►

- 19** The illustration below shows the locations of a rock as it rolls down a slope.

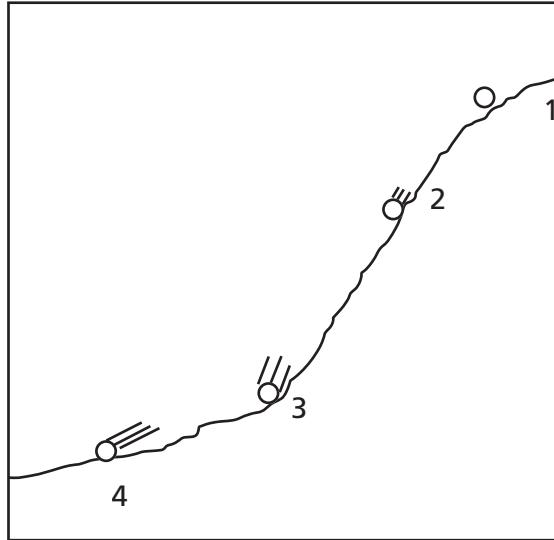

Which location shows the rock with the greatest potential energy?

- A** 1
  - B** 2
  - C** 3
  - D** 4
- 20** Three healthy plants are placed in a dark cabinet. Another three are placed in a window. All the plants are given the same amount of water. After one month, only the plants in the window are living. These results support which conclusion?
- F** Darkness will cause plants to grow.
  - G** Carbon dioxide is needed for growth.
  - H** Leaves need more time to grow.
  - J** Sunlight is needed for growth.



**21** An object moves rapidly as it is thrown upward. Its motion slows as it reaches a maximum height, and then it falls back down. What causes the upward motion to become slower?

- A** The kinetic energy is converted to wind energy.
- B** The kinetic energy is converted to gravitational potential energy.
- C** The gravitational potential energy is converted to kinetic energy.
- D** The gravitational potential energy is converted to light energy.

**22** Earth is shown between the sun and the moon in the diagram below.



Which type of moon will be viewed from Earth when Earth is between the sun and the moon?

- F** waning gibbous
- G** waxing crescent
- H** new moon
- J** full moon

**23** Which of these contains both abiotic and biotic elements in a desert environment?

- A** rocks and sunlight
- B** water and pebbles
- C** scorpions and sand
- D** roadrunners and snakes

**24** A rubber band is stretched between a person's fingers and then released. This best demonstrates

- F** products and reactants.
- G** friction and air resistance.
- H** physical and chemical changes.
- J** potential and kinetic energy.

**25** On a summer evening, a barometer reading shows a gradual increase in air pressure. The humidity is 80%. The thermometer reading is slightly increasing. Based on these data, what type of weather should be expected for the next day?

- A** clear and sunny
- B** cool and rainy
- C** rainy and windy
- D** cloudy and cold

**26** Water and ketchup are each poured onto a tray from two separate bottles. The charts below represent the amount of time it takes each liquid to flow from the top to the bottom of the tray.

Water Data		Ketchup Data	
Trial #	Time (sec.)	Trial #	Time (sec.)
1	2	1	35
2	3	2	35
3	2	3	40

What conclusion is best supported by the data?

- F** Thicker liquids take longer to travel to the bottom of a tray.
- G** Thicker liquids take less time to travel to the bottom of a tray.
- H** Liquid with sugar crystals travels to the bottom of a tray faster.
- J** Liquid with a darker color travels to the bottom of a tray faster.

- 27** A teacher uses a flashlight, an apple, and a walnut to show a lunar eclipse.

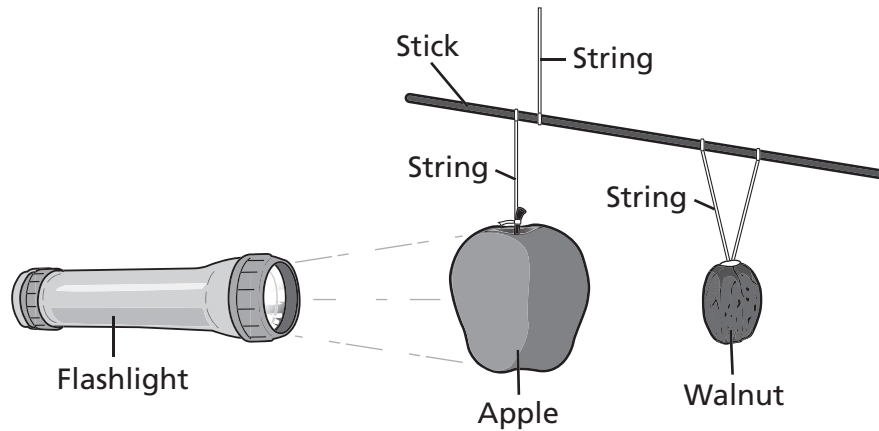

This lab setup best demonstrates that a lunar eclipse occurs during a

- A** new moon.
  - B** full moon.
  - C** first quarter moon.
  - D** crescent moon.
- 28** A meteorologist used radar to analyze the wind during a storm in the central plains of the United States. The winds were measured at 145 miles per hour and were moving in a circular pattern. According to the data, which event was the meteorologist most likely observing?
- F** lightning storm
  - G** tornado
  - H** rainbow
  - J** cloud formation

**29** What happens to some of the energy in a green plant when it is consumed by a deer?

- A** It is destroyed.
- B** It doubles in size.
- C** It helps maintain body heat.
- D** It is converted into a pure element.

**30** Which type of energy is converted when fireworks release heat, light, and sound?

- F** kinetic energy
- G** elastic potential energy
- H** chemical potential energy
- J** electromagnetic energy

**31** A student sees the moon and says, “The moon looks larger than the stars.” Which best explains why the student makes this observation?

- A** The moon is reflecting light from the sun.
- B** The moon is closer to Earth than the stars.
- C** The moon is much larger than the stars.
- D** The moon is much larger than Earth.

A group of students researched and collected data for a report on the weather in Nashville, Tennessee, for one year.

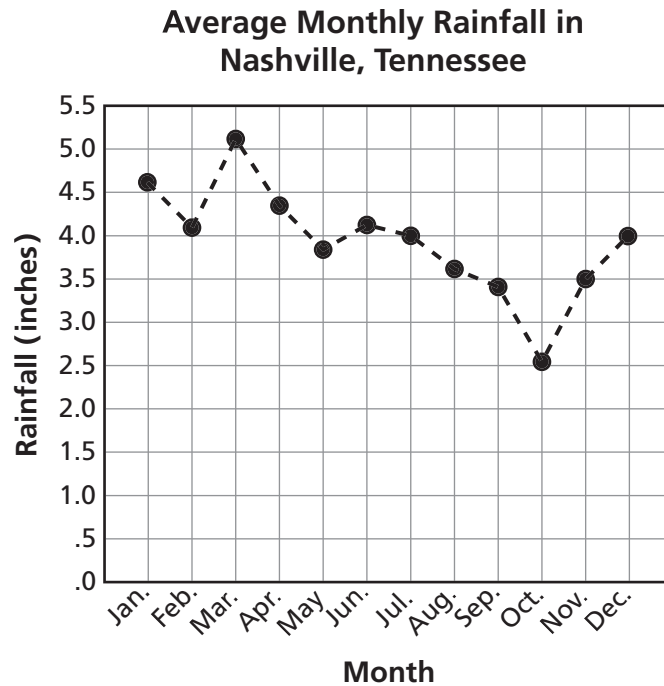

Based on the data, the students concluded that all cities in Tennessee will receive approximately 3.6 inches of rainfall next August. Which best explains why the students' conclusion is incorrect?

- F** The data collected did not include yearly rainfall amounts.
- G** The data collected did not include daily rainfall amounts.
- H** Rainfall averages were collected only from one city.
- J** Rainfall averages were not compared to a previous year.

**33** Which type of energy is being converted into kinetic energy as a marble falls from a shelf?

- A** electrical potential energy
- B** gravitational potential energy
- C** elastic potential energy
- D** chemical potential energy

**34** A battery is designed to provide improved power supply in areas with extremely low temperatures. Which test best determines if a prototype meets this goal?

- F** Compare the power of the prototype to the power of other standard batteries under normal conditions.
- G** Compare the lifetime of the prototype to that of a standard battery in a wide range of climate conditions.
- H** Compare the power storage of the prototype to that of a standard battery at cold temperatures.
- J** Compare the cost of materials for the prototype to the cost of materials for a standard battery.

Students counted the number of organisms located in a one-meter square plot in a grassland prairie. Their data are shown below.

Population Data

Organism	Number of Organisms
Ants	10
Beetles	2
Indian Grass	3
Goldenrod	4
Bluestem	8

Which graph best represents the data?

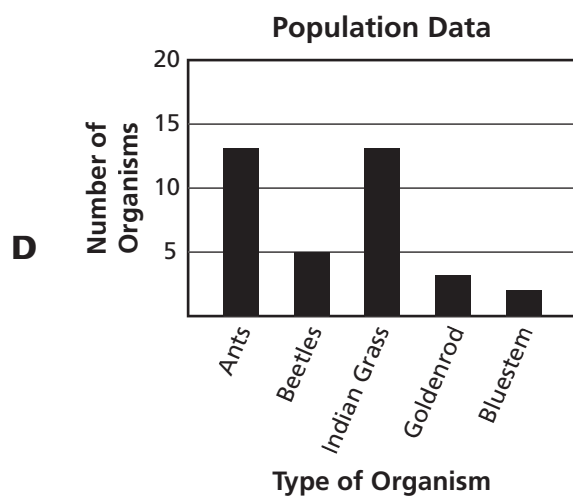
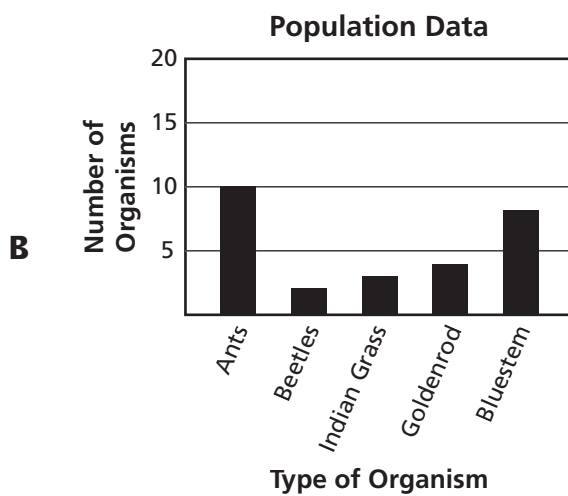
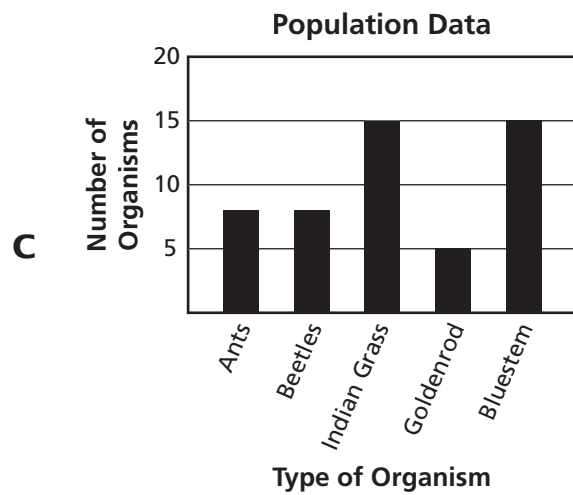
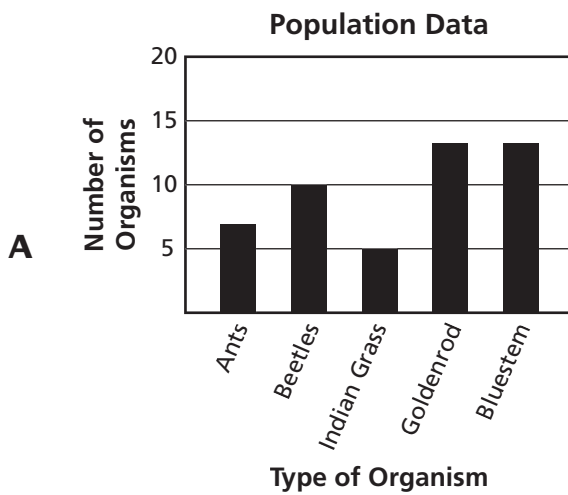

## Part 2

**36** What energy conversion occurs when a person rubs his or her hands together rapidly?

- F** electrical energy to thermal energy
- G** electrical energy to chemical energy
- H** thermal energy to kinetic energy
- J** kinetic energy to thermal energy

**37** A bottle company discovered that caps were being applied with too much force. This caused many bottles to break. Engineers adjusted the capping device so it applies less force to the caps.

Which steps should the engineers take before the adjustment is considered successful?

- A** adjust the capping device to increase the force applied by the bottle caps
- B** replace the bottle caps with different caps that cover a larger bottle opening
- C** compare the company's capping process to other companies' processes
- D** inspect bottles that have passed through the capping device after the adjustment



**38** The table below shows how hurricanes are classified based on the Saffir-Simpson scale.

**Hurricane Classifications**

Classification	Wind Speed (mph)	Level of Damage
Tropical storm	39–73	Minor
Category 1 hurricane	74–95	Minor damage, coastal flooding
Category 2 hurricane	96–110	Some structural damage, coastal flooding
Category 3 hurricane	111–130	Moderate damage, inland flooding
Category 4 hurricane	131–155	Major damage, flooding well inland
Category 5 hurricane	156 and higher	Severe damage, substantial inland flooding

One hour after a hurricane hit land, its wind speed had fallen to 98 miles per hour. What was the classification of the hurricane at that time?

- F** Category 1 hurricane
- G** Category 2 hurricane
- H** Category 3 hurricane
- J** Category 4 hurricane

**39** What type of energy transfer is taking place as the coils in a toaster heat?

- A** chemical to thermal
- B** nuclear to electrical
- C** thermal to mechanical
- D** electrical to radiant

*Go On* ►

- 40** The data table shows land and water temperatures along a beach during a one-day period.

**Coastal Temperatures Data Table**

Land Temperature (°C)	Water Temperature (°C)
24	22
28	22
33	23
32	25

In what way can the data be used to make a prediction?

- F** Inland temperatures will help cause tidal surges.
- G** Water temperatures will help determine coastal temperatures.
- H** Coastal temperatures will help determine sea levels.
- J** Water temperatures will help cause inland soil erosion.

- 41** A company designed an electromagnetic tool that removes dents from metal plates. The dented metal is placed between two magnets. A current is then supplied to the electromagnets. The attraction between the two magnets forces the dented metal plate back into place. How can engineers test to see if their design is successful?

- A** compare the cost of operating the tool to other dent removal tools
- B** compare the shape of the treated metal with the original shape of the metal
- C** compare the type of metal plates treated by the company to those of other companies
- D** compare the energy requirements of two similar dent removal tools

**42** Which diagram best shows the position of Earth, the moon and the sun when there is a new moon?

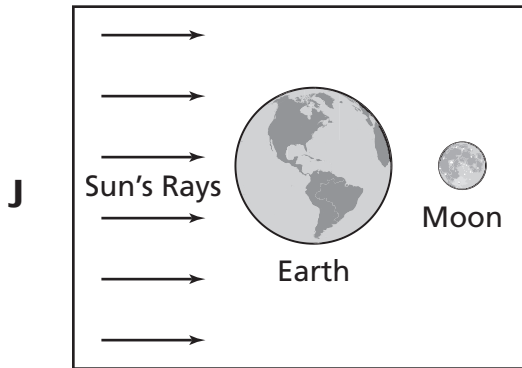
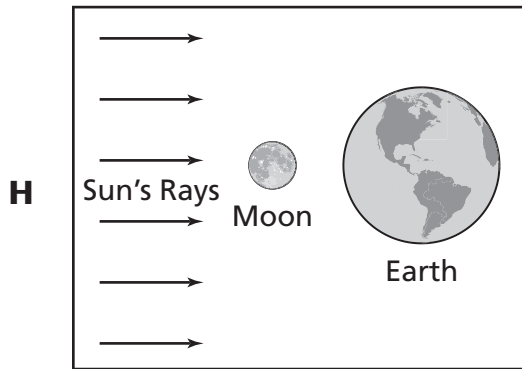
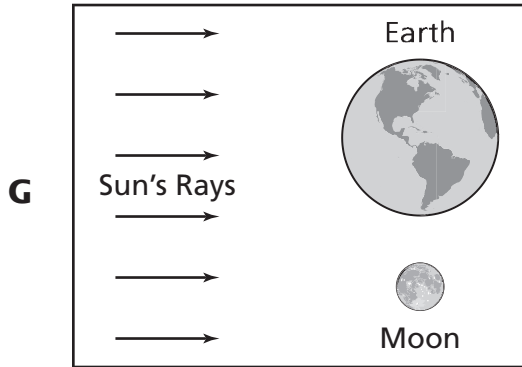
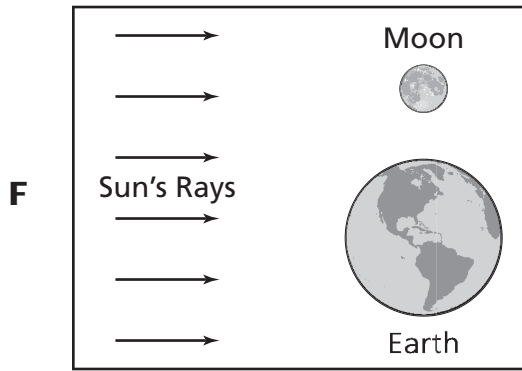

**43** A diagram of a roller coaster moving to the top of a hill is shown below.

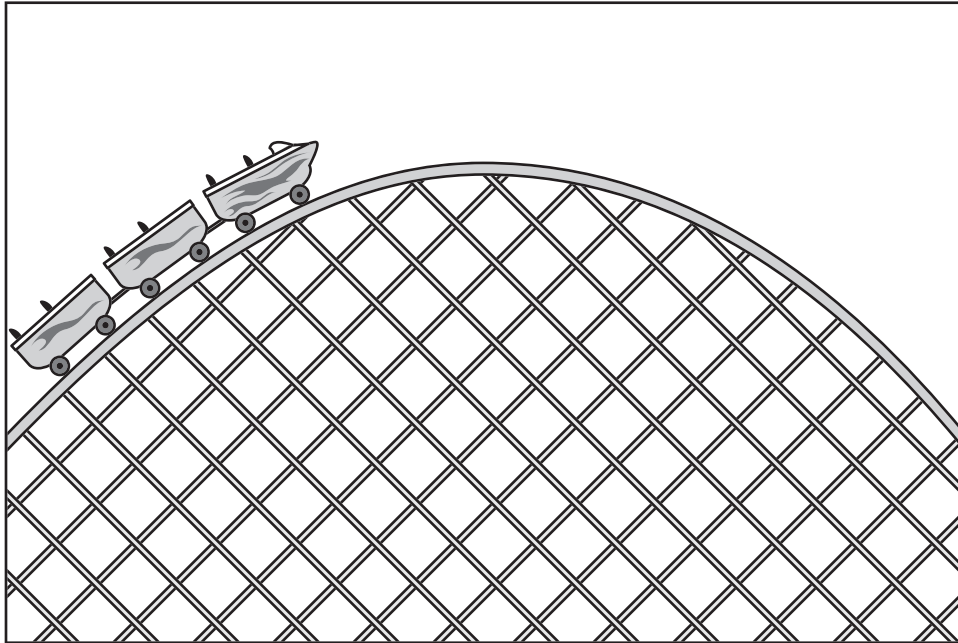

Which type of energy will be greatest at the top of the hill?

- A** chemical potential energy
- B** nuclear potential energy
- C** elastic potential energy
- D** gravitational potential energy

- 44** The table lists some characteristics of objects in our solar system.

**Objects in Our Solar System**

Object	Location	Diameter
Asteroid	Orbits the sun	Up to 1,000 km
Moon	Orbits a planet	Up to 5,268 km
Halley's Comet	Orbits the sun	8 km
Planet in solar system	Orbits the sun	4,880–142,800 km

Scientists observe an object with a diameter of 950 km in an orbit around the sun. Scientists will most likely identify it as which type of object?

- F** Asteroid
- G** Moon
- H** Comet
- J** Planet

- 45** When a button is pushed, a circuit is completed and a buzzer is activated. The buzzer transferred electrical energy into
- A** sound energy.
  - B** chemical energy.
  - C** light energy.
  - D** nuclear energy.

- 46** Which is the best example of an assistive bioengineered product?
- F** a rosebush that is bred to have roses of a particular color
  - G** a computer program that helps a paralyzed person control a wheelchair
  - H** a pesticide produced from the compounds of a plant
  - J** a bacterium that generates oil byproducts in the presence of sunlight

**47** A grassland food web is shown below.

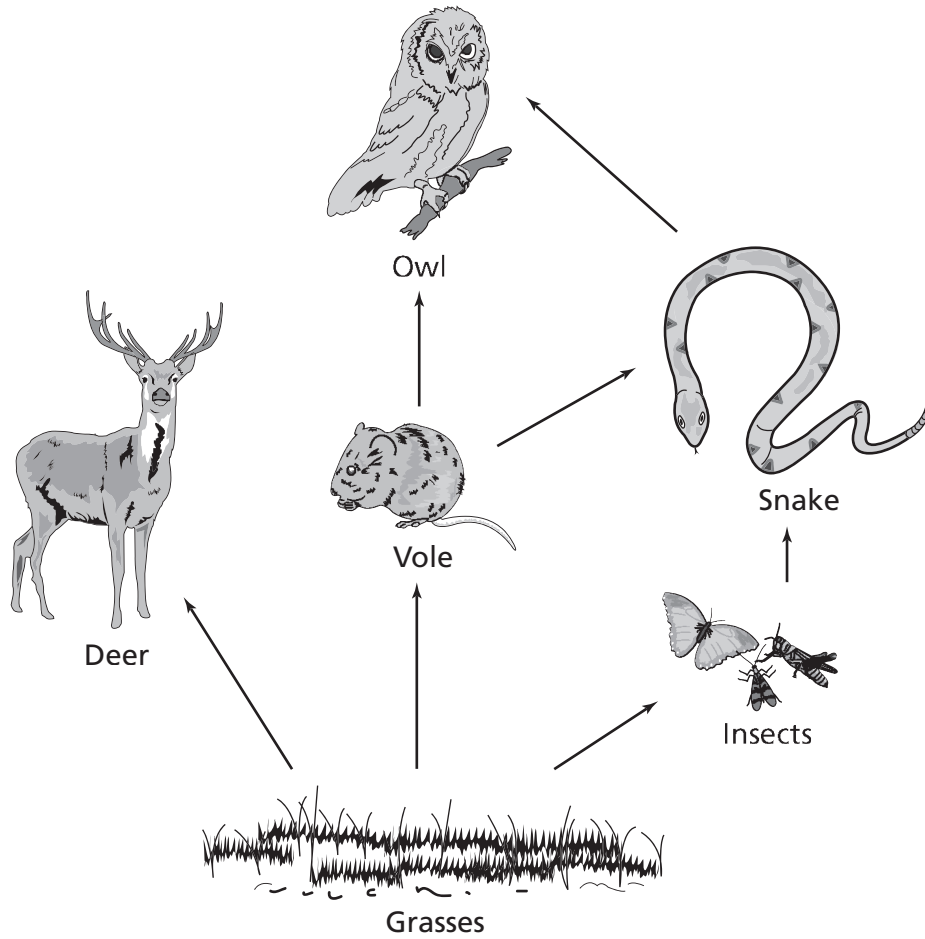

The owl most directly obtains energy from which organism?

- A** Vole
- B** Insects
- C** Deer
- D** Grasses

**48** Which diagram best represents one day on Earth?

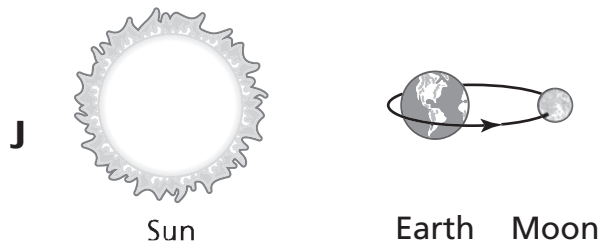
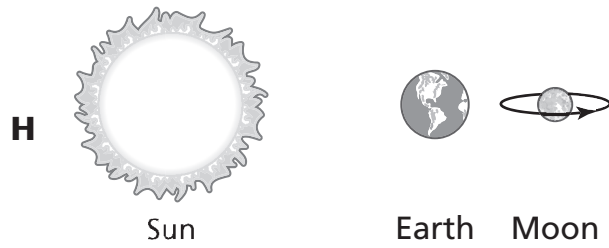
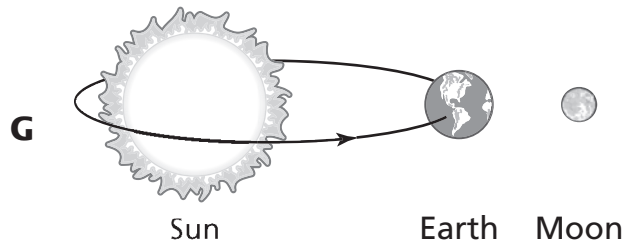
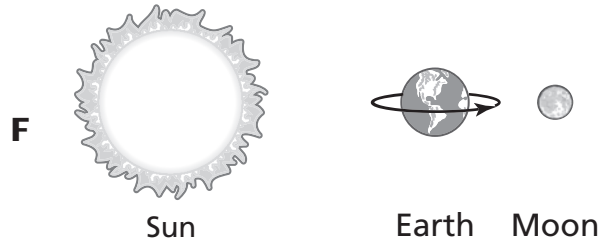



**49** Which is the best example of chemical potential energy?

- A** a book resting on a shelf
- B** a stretched rubber band
- C** a fuel tank containing gasoline
- D** a pencil falling off a table

**50** Cold ocean currents are most likely to be located at deeper ocean depths than warm water currents because

- F** winds push the cold water down.
- G** ocean tides force cold water downward.
- H** cold water is more dense and sinks.
- J** cold water has less salt to help it freeze and sink.

**51** A prairie food web is shown below.

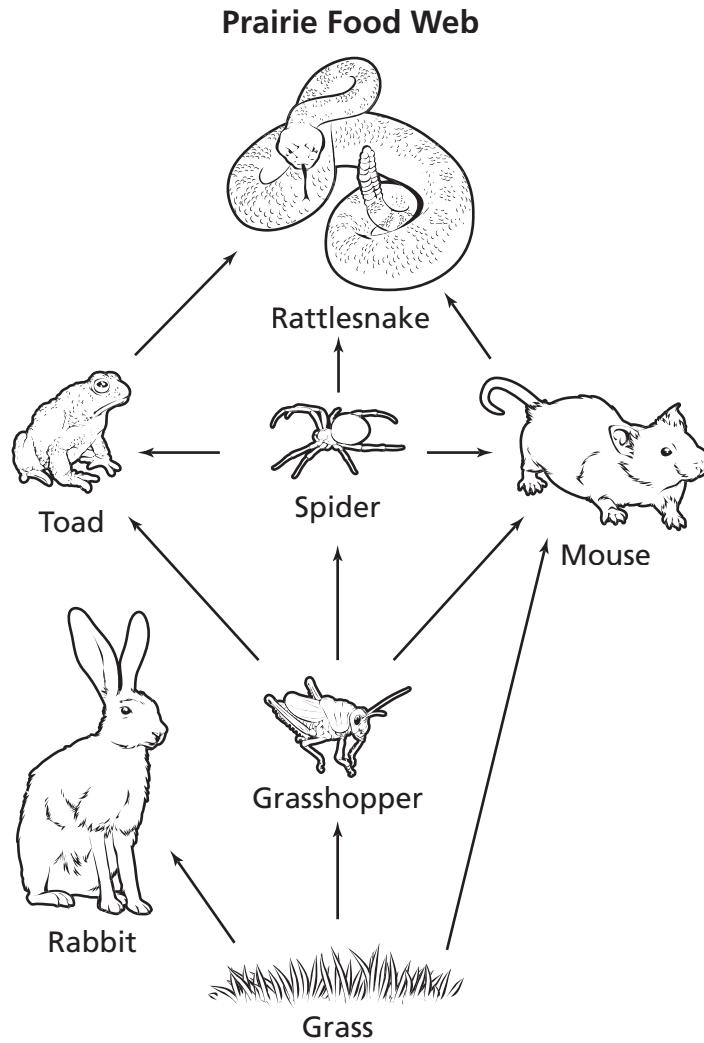

Which group of organisms is made up of only consumers?

- A** Spider, Grass, Mouse
- B** Toad, Grass, Rabbit
- C** Grasshopper, Mouse, Grass
- D** Rattlesnake, Grasshopper, Spider

**52** What can happen when the moon passes between Earth and the sun?

- F** The sun lights both sides of the moon.
- G** The moon blocks the light of the sun.
- H** The sun blocks the view of the moon.
- J** The moon stops the sun from producing light.

*Go On* ►

**53** A diagram of the sun, Earth, and the moon is shown below.

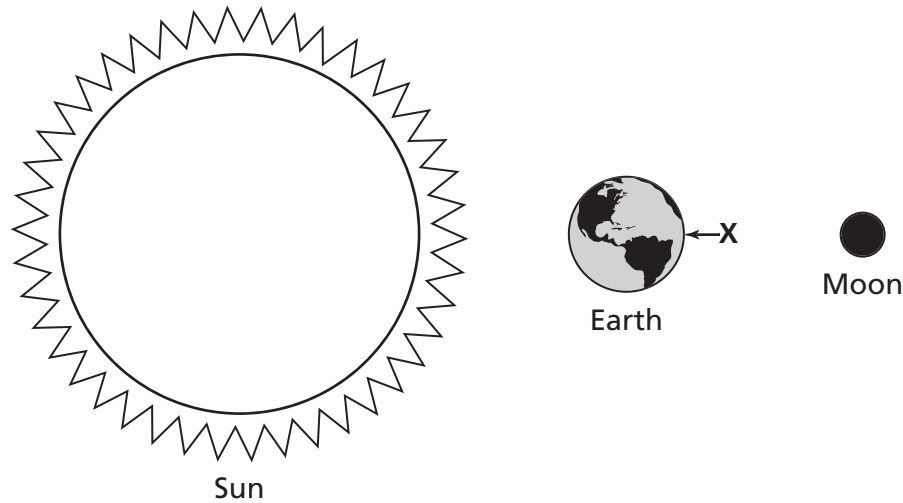

When the sun, Earth, and the moon are aligned in the positions shown in the diagram, what type of ocean tide occurs at location X?

- A** red tides near the coast
- B** rip tides near the coast
- C** highest high tides
- D** lowest high tides

**54** Which most likely causes the movement of warm surface ocean currents?

- F** Sunlight heats air forming strong winds that push currents.
- G** Low and high tides create energy for current movement.
- H** Shifting ocean plates force water toward the poles.
- J** Warm waters help in the melting of icebergs and glaciers.

**55** Each diagram shows a circuit. The number one represents a buzzer and the number two represents a clock. Which diagram most likely shows a circuit producing sound?

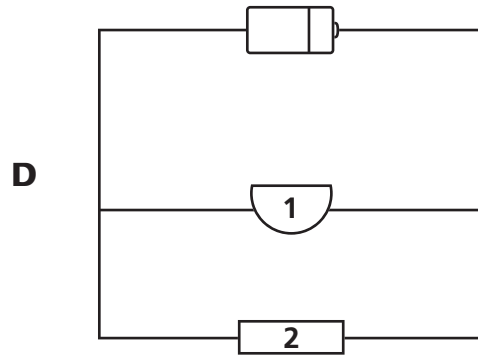
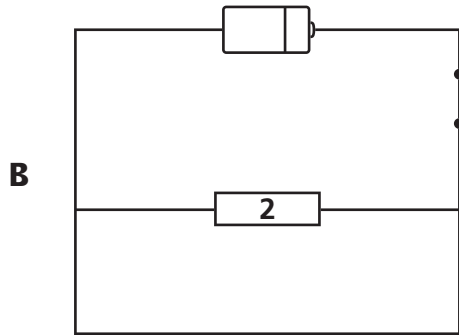
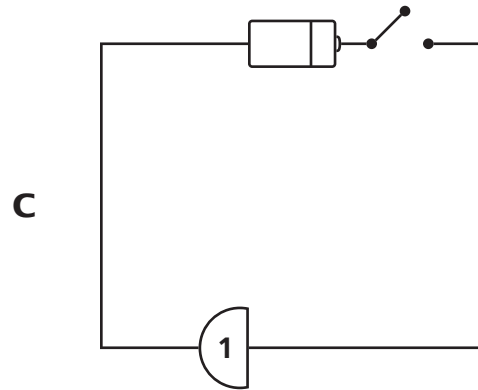
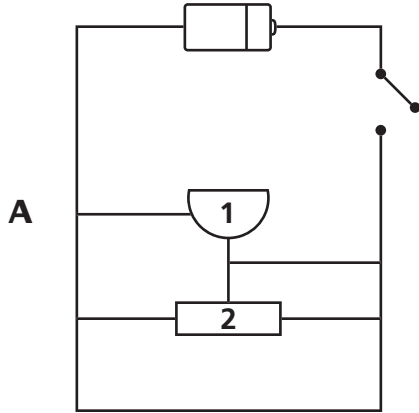

*Go On* ►

**56** The drawing below shows a sea breeze.

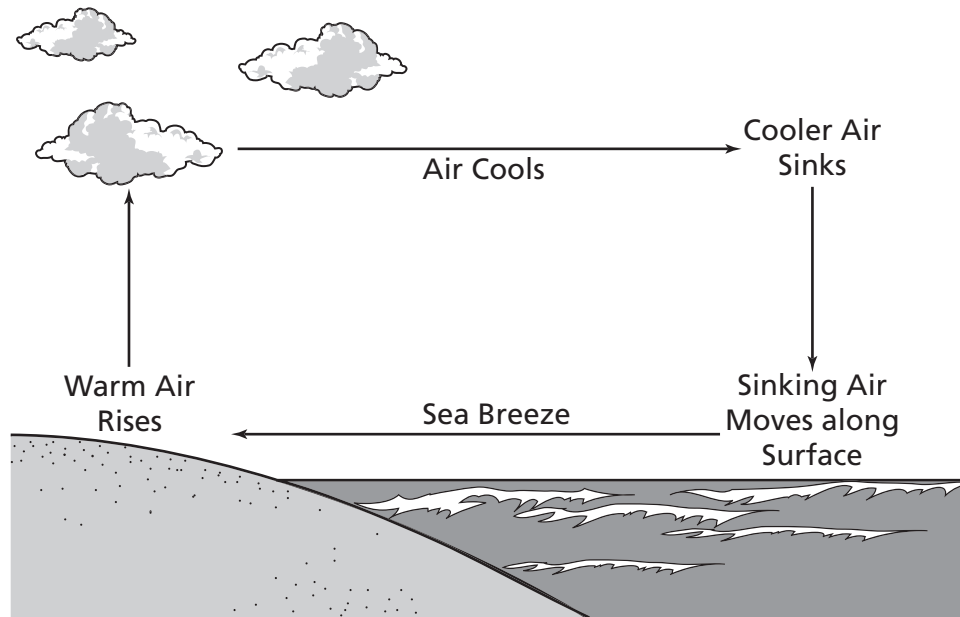

When is this type of wind pattern most likely to occur?

- F** during the day when the land heats faster than the surface of the sea
- G** during the night when the surface of the sea cools faster than the land
- H** during the day when the sea is as warm as the land
- J** during the night when the air above land is warmer than the air above the sea

**57** Inside a power plant, coal is burned to produce hot gases. What type of energy conversion takes place as hot gases cause turbines to move?

- A** thermal energy to chemical energy
- B** thermal energy to kinetic energy
- C** electrical energy to kinetic energy
- D** kinetic energy to thermal energy

**58** The Arctic tundra provides a habitat for caribou and arctic hare. Which best describes the climate in which these animals live?

- F** cold and humid
- G** warm and dry
- H** cold and dry
- J** warm and humid

**59** Venus appears very bright in the night sky because it

- A** has a gravitational field.
- B** is the largest planet.
- C** is the closest planet to Earth.
- D** has a high surface temperature.

**60** When turning on a flashlight, a chemical reaction in the battery produces electricity that lights a bulb.

**According to the Law of Conservation of Energy, the energy exchanged between the battery and the flashlight**

- F** is created.
- G** loses matter.
- H** is destroyed.
- J** changes forms.

**61** The barometer reading on a local weather forecast was 29.80 mm Hg and falling. What type of weather conditions are most likely about to occur?

- A** clear and cool
- B** clear and warm
- C** fair skies
- D** cloudy skies

**62** The soil in a deciduous forest typically contains many nutrients and supports the growth of various plants. Which statement explains why the soil is so nutrient rich?

- F** The daily rainfall adds minerals to the soil.
- G** The temperature of the soil is perfect for plants to grow.
- H** The amount of sunlight the soil gets is perfect for plants.
- J** The soil is high in organic matter from decomposers.



**63** Ocean currents bring deep, nutrient-rich water to the surface. What causes these currents to move upward?

- A** Warm rainwater mixes with surface water, pushing deep water upward.
- B** Cold surface water from the poles sinks, pushing deep water upward.
- C** Wind currents cause surface water to sink, pushing deep water upward.
- D** Surface runoff from rivers causes warm water to sink, pushing deep water upward.

**64** A ball is at rest until a paddle exerts force as shown below.



What kind of energy is shown by the ball as it is moving away from the paddle?

- F** potential energy
- G** kinetic energy
- H** chemical energy
- J** nuclear energy

**65** Which organisms are most important for adding nutrients to the soil?

- A** consumers
- B** scavengers
- C** producers
- D** decomposers

**66** What causes a lunar eclipse to occur?

- F** The moon's shadow falls on Earth.
- G** Earth's shadow falls on the moon.
- H** The moon's shadow falls on the sun.
- J** The sun's shadow falls on Earth.

**67** Which tool is most useful to observe the moons of Jupiter to help record their motion?

- A** microscope
- B** telescope
- C** balance
- D** binoculars

**68** Approximately how long does it take the moon to complete one cycle of phases?

- F** a month
- G** a day
- H** a year
- J** a week

**69** Which activity within our solar system takes approximately one year to complete?

- A** Halley's comet revolving around the sun once
- B** a distant star revolving around Earth once
- C** Earth revolving around the sun once
- D** the moon revolving around Earth once

**STOP** 

**DO NOT  
MARK  
ON THIS  
PAGE**

# Social Studies

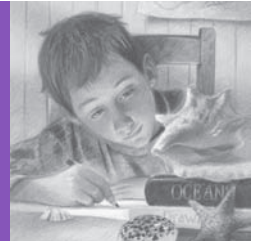

## Part 1

?

- Language
- Religion
- Traditions
- Values

**1** Which term is the best title for the list above?

- A** Technology
- B** Culture
- C** Government
- D** Economy

**2** Which of these years came before the year 25 B.C.E.?

- F** 5 C.E.
- G** 10 B.C.E.
- H** 100 C.E.
- J** 50 B.C.E.

*Go On* ►

**3** The preservation of classical texts during the Middle Ages was most often accomplished in

- A** shops.
- B** guilds.
- C** monasteries.
- D** manors.

**4** Martin Luther is best known for

- F** conquering the Iberian Peninsula.
- G** writing about his travels to China.
- H** leading a religious reform movement.
- J** starting a missionary religious order.

## Totem Pole



© Fotandy/Dreamstime #1265103

**5** Which culture developed artifacts like the one pictured above?

- A** Medieval European
- B** Ancient Roman
- C** Classical Greek
- D** Native American

*Go On* ►

## Ancient Civilizations

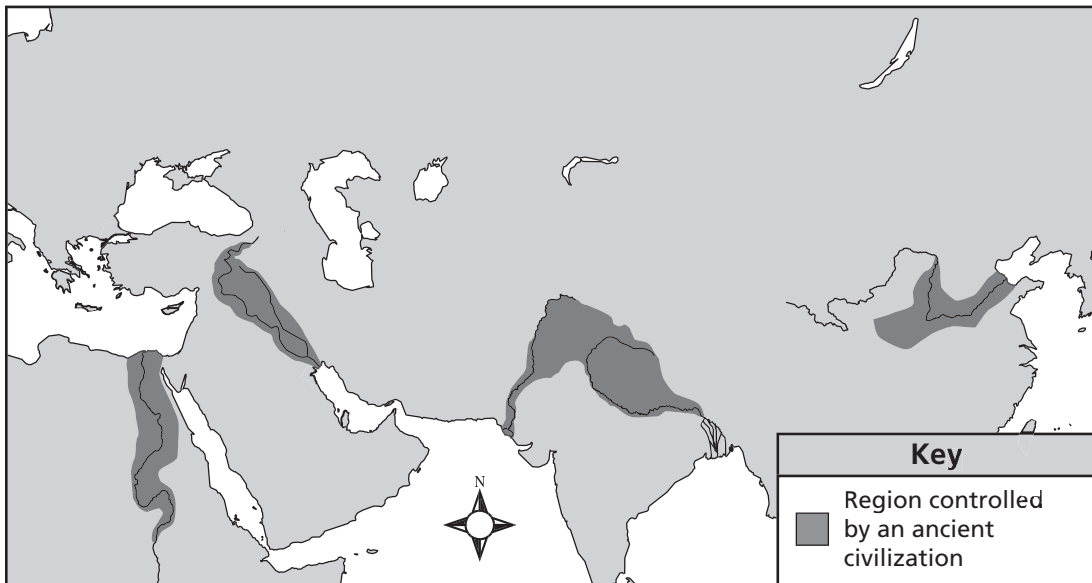

**6** Which civilization on the map above developed farthest to the west?

- F** Indian
- G** Chinese
- H** Egyptian
- J** Mesopotamian



Scythe

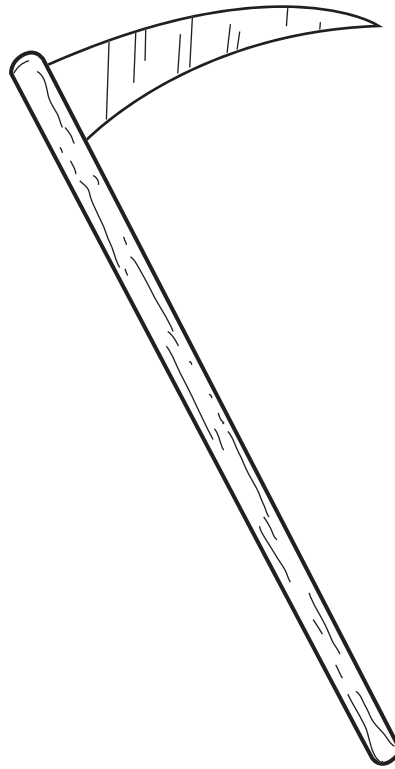

**7** The technological advance pictured above is important because it helped early civilizations

- A** transport goods.
- B** record events.
- C** build homes.
- D** grow food.

**8** Which of these statements best describes a barter economy?

- F** People trade with one another for goods.
- G** People use credit cards to make purchases.
- H** People put the money they earn into banks.
- J** People grow everything they need.

- Ruler of Normandy
- Invaded England in 1066
- Transformed English feudal system
- Established the Domesday Book

**9** Who is described by the list above?

- A** Charlemagne
- B** Julius Caesar
- C** Alexander the Great
- D** William the Conqueror

**Directions**

Use the timeline below and your own knowledge to do Numbers 10 and 11.

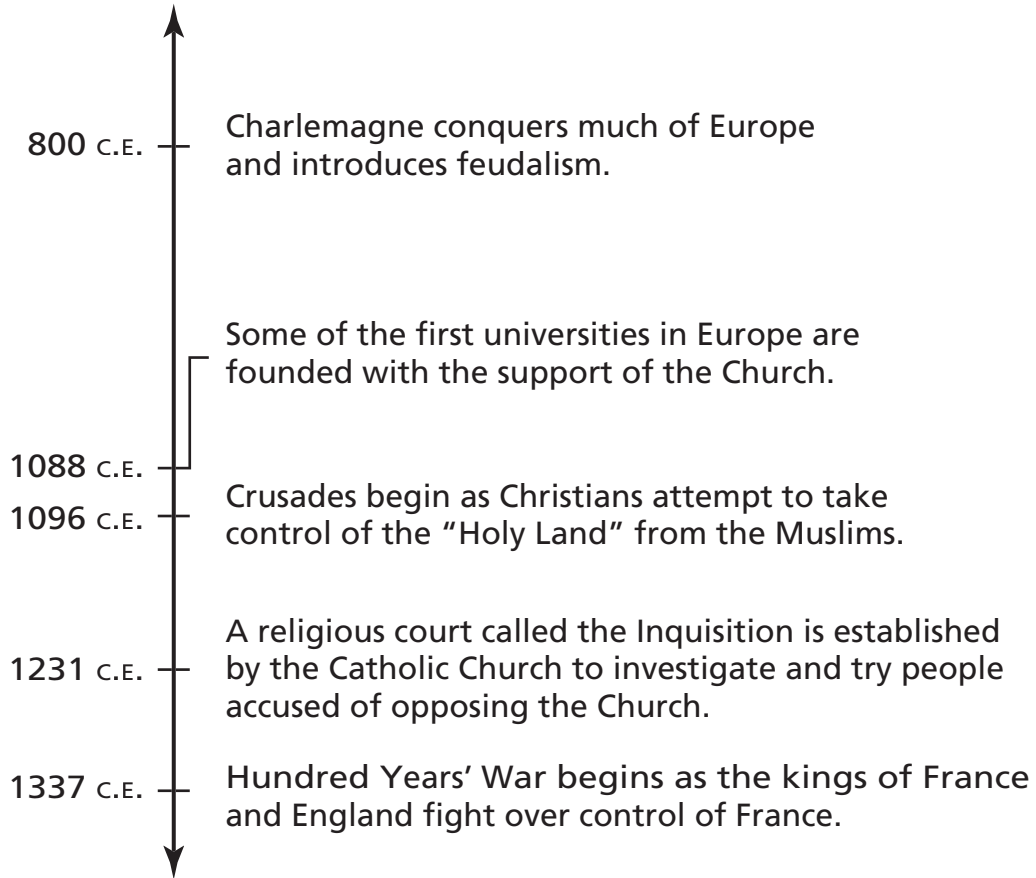
**Some Events During the Middle Ages**

Note: Dates are approximate.

**10** The information shown on the timeline suggests that during the Middle Ages

- F** people of all classes had equal rights.
- G** most rulers were elected by the people.
- H** England and France maintained peace.
- J** the Church controlled many aspects of people's lives.

*Go On* ►

**11** Which of these events could also be placed on the timeline?

- A** the founding of Christianity
  - B** the building of the Great Pyramid
  - C** the outbreak of the plague in Europe
  - D** the development of city-states in Greece
- 

**12** The main purpose of a map key is to show

- F** the cardinal directions.
- G** the meaning of the symbols.
- H** the distance between places.
- J** the names of the cities.

Expansion of Greece and Its Colonies, 550 B.C.E.

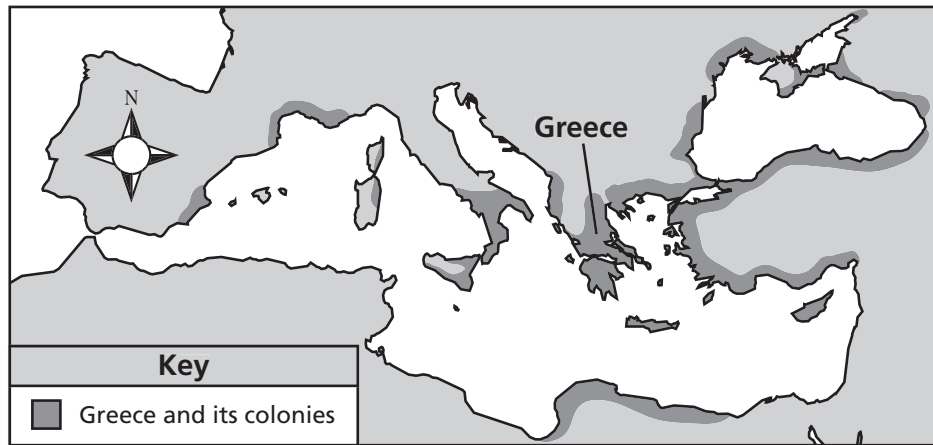

**13** Which factor contributed most to the expansion shown on the map?

- A** drought
- B** invasion
- C** flood
- D** trade

a body of water completely surrounded by land

**14** Which of these best fits the definition above?

- F** bay
- G** harbor
- H** lake
- J** strait

**15** Renaissance philosophers affected the way people thought by

- A** developing artistic styles that criticized religious leaders.
- B** asking people to question ideas that had been taken for granted.
- C** promoting the importance of following the teachings of royalty.
- D** asking people to continue following traditional beliefs.

**16** Which of these was an advantage most early farming communities had over nomadic communities?

- F** availability of permanent shelter
- G** smaller population size
- H** less need for rules and regulations
- J** more opportunities to explore new lands

**17** A scholar could study which epic to learn about early Indian culture?

- A** *The Aeneid*
- B** *Gilgamesh*
- C** *Mahabharata*
- D** *The Odyssey*

**18** The spread of Islam during the 8th century had the most influence on the cultures of which of these regions?

- F** Western Europe
- G** Eastern Asia
- H** North Africa
- J** South America

**19** The year 500 B.C.E. belongs in which era?

- A** Renaissance
- B** Classical Period
- C** Dark Ages
- D** Middle Ages

- Heard a call to save the nation
- Defeated the English army at Orléans
- Was tried by the English and executed

**20** Who is described by the list above?

- F** King Ferdinand II
- G** William of Normandy
- H** Joan of Arc
- J** Queen Elizabeth I

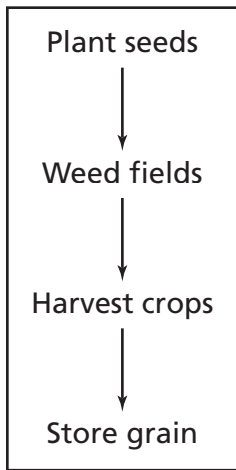

**21** Which type of early community is described by the flow chart above?

- A** fishing
- B** hunter-gatherer
- C** farming
- D** nomadic



### Japanese Social Hierarchy, c. 1400

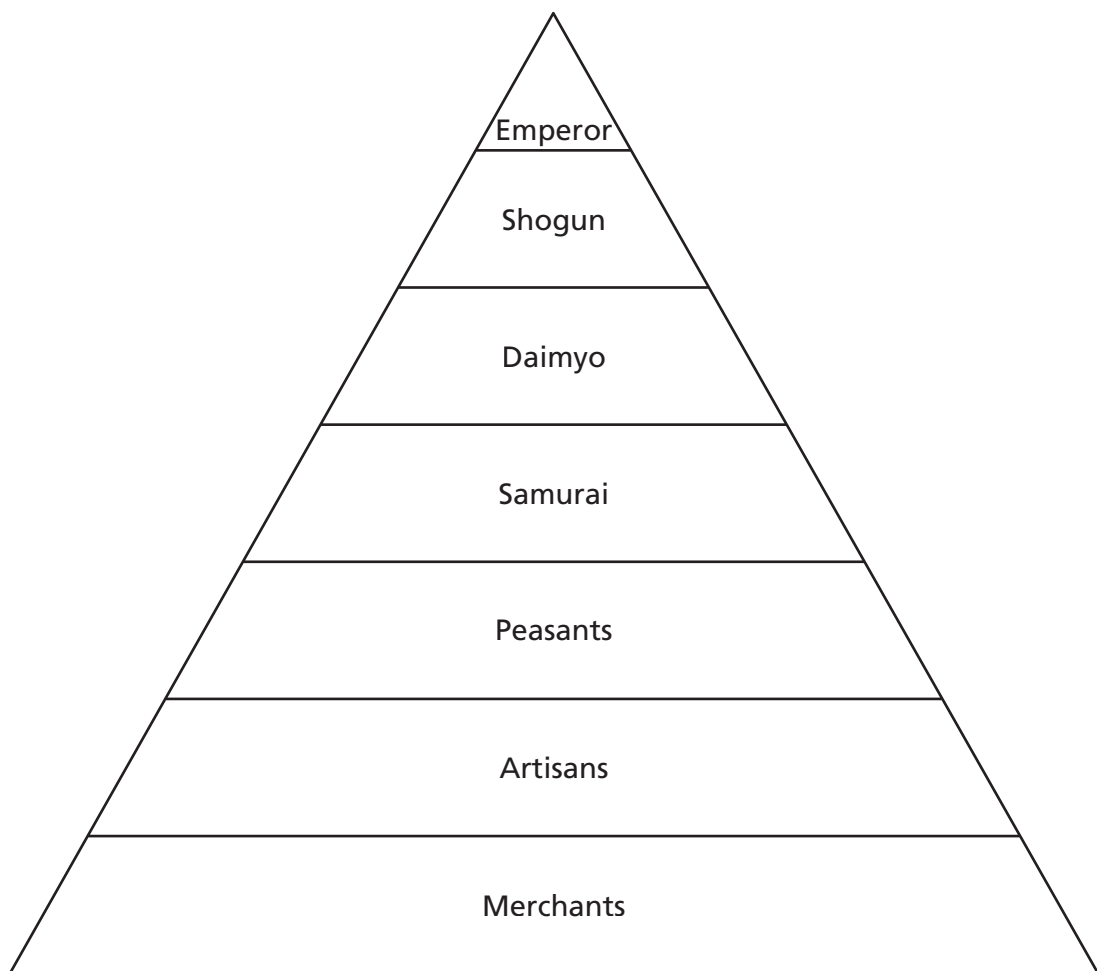

**22** Based on the diagram above, which level of Japanese society was least respected?

- F** Emperor
- G** Artisans
- H** Peasants
- J** Merchants

*Go On* ►

- 23** In the 1400s and 1500s many European nations explored other parts of the world. Which of these best describes the main goal of these explorations?
- A** to promote religious freedom
  - B** to learn about other ways of life
  - C** to help the economies of other nations
  - D** to gain access to wealth

- 24** Which statement best explains why desert regions surrounding the Nile River helped the ancient Egyptian civilization develop?
- F** They made it easier to trade with other cultures.
  - G** They provided food and water to meet basic needs.
  - H** They were barriers that prevented enemy invasions.
  - J** They supplied the wood needed to build sailing ships.

- 25** Which of these was the main reason for the fall of democratic government in ancient Athens?
- A** earthquakes that destroyed the city
  - B** drought that ruined crops in Greece
  - C** shortages caused by overpopulation
  - D** warfare with other Greek city-states

**Directions**

Use the map below and your own knowledge to do Number 26.

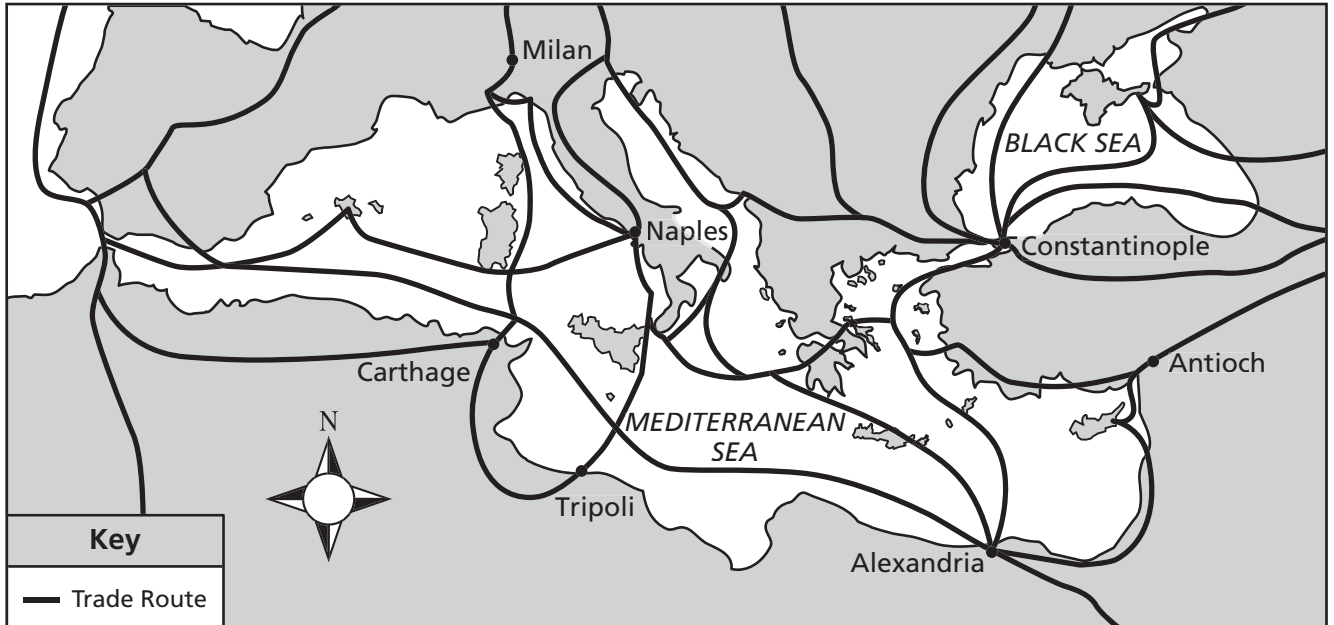
**Some Trade Routes in Medieval Europe**

**26** Based on the map, which statement about trade routes in medieval Europe is true?

- F** Most traders used all of the routes.
- G** Few of the trade routes were over land.
- H** The Mediterranean Sea was an important trade route.
- J** The trade routes reached beyond the Atlantic Ocean.

*Go On* ►

**27** Which sentence is an example of direct democracy?

- A** Citizens defend their country.
- B** Citizens elect senators.
- C** Citizens pay taxes.
- D** Citizens vote on laws.

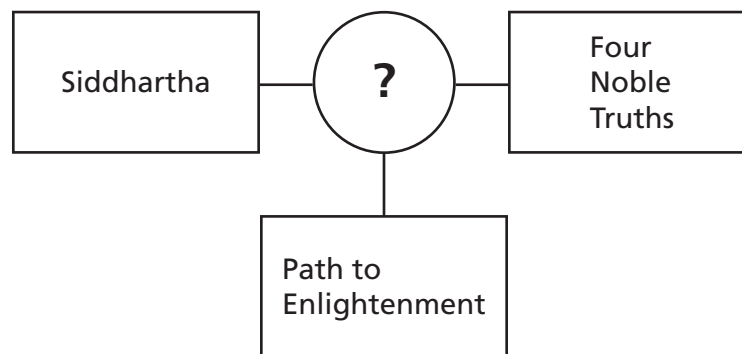

**28** Which religion completes the diagram above?

- F** Buddhism
- G** Islam
- H** Shintoism
- J** Taoism

- Emperor
- Senate
- Forum

**29** Which ancient civilization is most associated with the terms listed in the box above?

- A** Chinese
- B** Egyptian
- C** Mesopotamian
- D** Roman

- establishment of laws
- organization of public works projects such as public buildings

**30** A government system capable of performing the actions described above would most likely have been found in a

- F** city.
- G** village.
- H** farming community.
- J** nomadic community.

**31** Which term describes imperial China during the European Renaissance?

- A** tribal
- B** nomadic
- C** isolationist
- D** impoverished

*Go On* ►

**32** Renaissance philosophers developed their ideas in part by studying the works of

- F** classical Greece.
- G** ancient India.
- H** early Egypt.
- J** medieval Japan.

**33** The purpose of Hammurabi's Code was to establish

- A** safe travel on roads.
- B** procedures for religious rituals.
- C** methods for hunting and gathering food.
- D** laws and the penalties for breaking them.

Ganesha



Shiva



**34** Which ancient society is the origin of the religion represented by the images above?

- F** Greece
- G** India
- H** Rome
- J** Egypt

**35** Which of these inventions most affected the way people travel?

- A** iron tools
- B** printing press
- C** irrigation ditch
- D** magnetic compass

## Part 2

**36** Which field of study compares different cultural groups?

- F** anthropology
- G** paleontology
- H** geology
- J** psychology

**37** The myth of Romulus and Remus is a story about the

- A** birth of humanity.
- B** fall of an empire.
- C** founding of a city.
- D** creation of the world.

**38** Which description is evidence that a society had a barter economy?

- F** They stored the extra food they had produced.
- G** They went from place to place looking for food.
- H** They settled on land that was good for growing their food.
- J** They traded their extra food for goods made by other people.



**39** One difference between the development of civilizations in India and Egypt was the

- A** growth of cities.
- B** influence of Hinduism.
- C** development along rivers.
- D** interaction with the Native American civilization.

**40** Which of these factors has enabled North America's Inuit population to survive the harsh Arctic climate?

- F** food high in protein
- G** profit from coal mines
- H** access to forestry products
- J** ease of travel to populated areas

**41** Which development most contributed to the success of ancient Mesopotamian villages?

- A** terraced farming
- B** irrigation methods
- C** advanced mathematics
- D** papyrus records

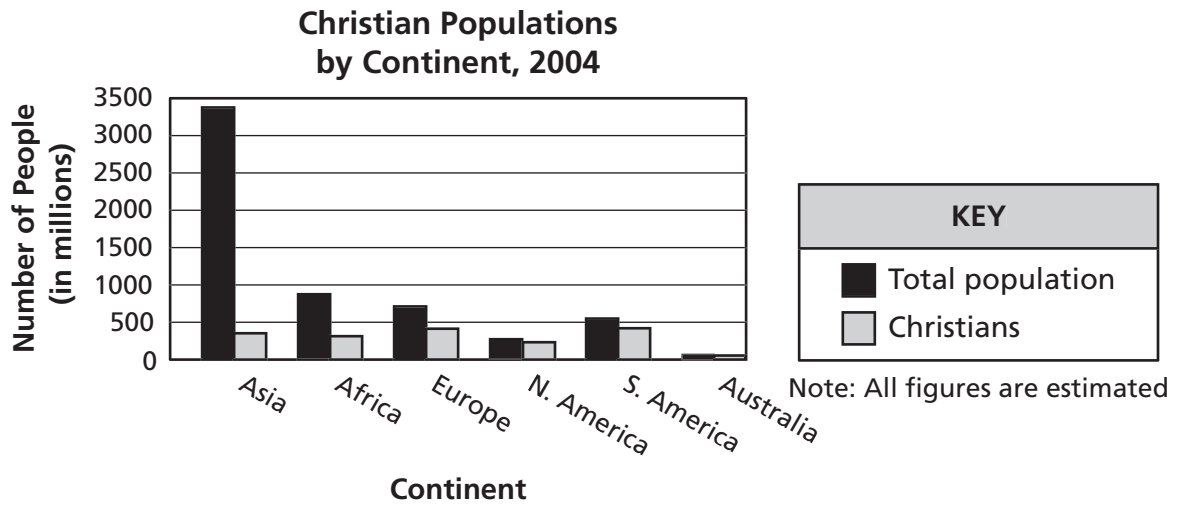

**42** The information shown on the graph suggests that Christianity

- F** spread to all inhabited continents.
- G** became the main religion on every continent.
- H** was limited to the Americas.
- J** originated in Western Europe.

## The Parthenon



© Mellis82/Dreamstime #7038006

**43** The image above shows the ruins of a structure built by which ancient culture?

- A** China
- B** Egypt
- C** Greece
- D** India

*Go On* ►

**Directions**

Use the timeline below and your own knowledge to do Numbers 44 and 45.

### Developments in the Ancient World

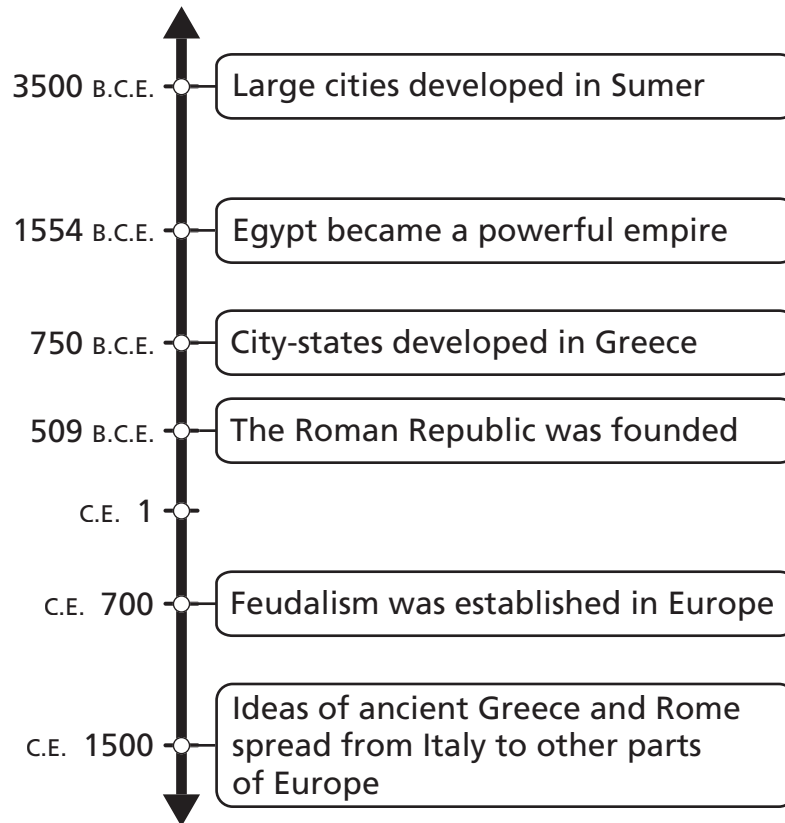

Note: Dates are approximate.

4000 B.C.E. – Ships from Crete traveled the Mediterranean

**44** Where on the timeline should this information be placed?

- F** before the development of large cities in Sumer
- G** after the spread of ancient Greek and Roman ideas throughout Europe
- H** between Egypt becoming an empire and the development of city-states in Greece
- J** between the founding of the Roman Republic and the establishment of feudalism in Europe

**45** Which of these events occurred closest in time to the founding of the Roman Republic?

- A** City-states developed in Greece.
- B** Egypt became a powerful empire.
- C** Feudalism was established in Europe.
- D** Ideas of Greece and Rome spread to other areas.

**Objects Made in Ancient Egypt**

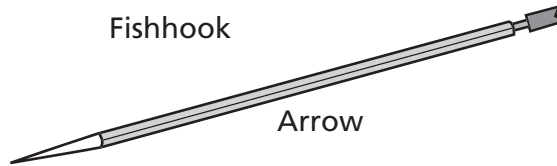

**46** The types of artifacts shown provide the most information about one of the ways people in ancient Egypt

- F** built shelters.
- G** obtained food.
- H** traded goods.
- J** practiced religion.

**47** Which language spread throughout North Africa and the Middle East as a result of the expansion of Islam?

- A** Hindu
- B** Arabic
- C** Hebrew
- D** Aramaic

Leader	Action	Effect
Augustus Caesar	Increased size of Roman army	?

**48** Which phrase best completes the table above?

- F** Granted citizens the right to vote
- G** Established new trade alliances
- H** Guaranteed freedom of speech to citizens
- J** Created an empire

**49** Which of these time periods is a decade?

- A** 1100 to 1200
- B** 1899 to 1900
- C** 1350 to 1400
- D** 1010 to 1020

**50** Which ancient civilization used hieroglyphics?

- F** Egypt
- G** Babylon
- H** Mesopotamia
- J** Sumeria

**51** An era of exploration began at the end of the Middle Ages because Europeans

- A** needed lands for a growing population.
- B** wanted to find new trade routes to China.
- C** became interested in medical research.
- D** ceased trading in the Mediterranean region.

**Major Religions in South Asia**

Hinduism	?
Belief in many gods	Believe Allah is the only God
Practice meditation	Prayer five times a day

**52** Which religion completes the table above?

- F** Islam
- G** Buddhism
- H** Christianity
- J** Taoism

**53** Martin Luther changed Christian theology by

- A** challenging the authority of the Pope.
- B** designing the cathedral at Worms.
- C** leading the Children's Crusade.
- D** demanding a split with Eastern Orthodoxy.

**?**

- Domesticated animals
- Invention of new tools
- Irrigation systems

**54** Which type of ancient community best titles the above list?

- F** Farming
- G** Nomadic
- H** City-state
- J** State

**55** Which person travels to unfamiliar places looking for riches and to spread religion?

- A** an inventor
- B** an explorer
- C** a philosopher
- D** a military leader



**Directions**

Use the map below and your own knowledge to do Number 56.

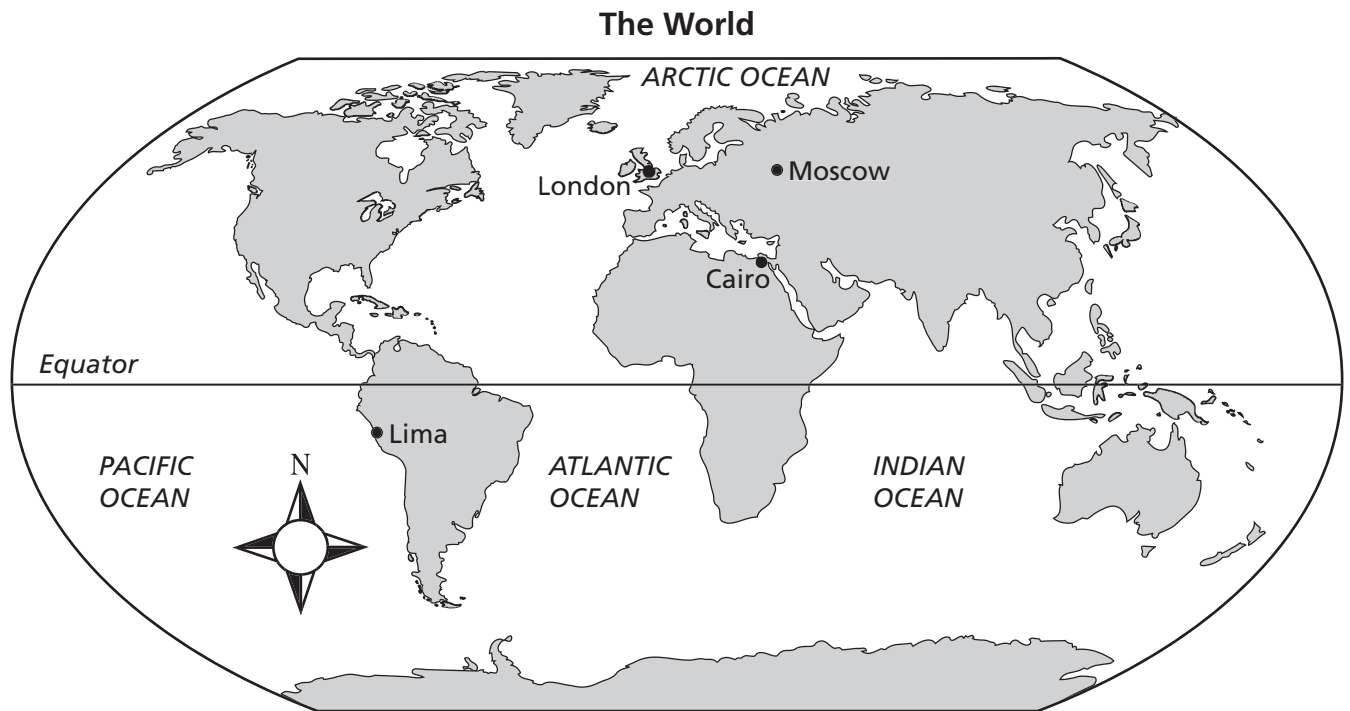

**56** According to the map, which of these cities is located farthest south?

- F** Cairo
  - G** Lima
  - H** London
  - J** Moscow
- .....

**57** The ancient Greek city-state of Sparta had a society organized on which principle?

- A** monotheism
- B** philosophy
- C** militarism
- D** equality

*Go On* ►

**58** Joan of Arc changed the course of world history by

- F** exploring new lands and claiming them for France.
- G** leading French resistance against an invasion by England.
- H** writing plays that showed the hardships suffered by the poor.
- J** developing new ways of treating injuries suffered by soldiers during battle.

**59** Which Renaissance thinker is best known for building a telescope and studying lunar craters?

- A** René Descartes
- B** Nicolaus Copernicus
- C** Galileo Galilei
- D** Gerhardus Mercator

**60** Which document helped to establish the principle of limited government?

- F** Domesday Book
- G** Justinian Code
- H** Magna Carta
- J** Napoleonic Code

Roman Empire, 395 C.E.

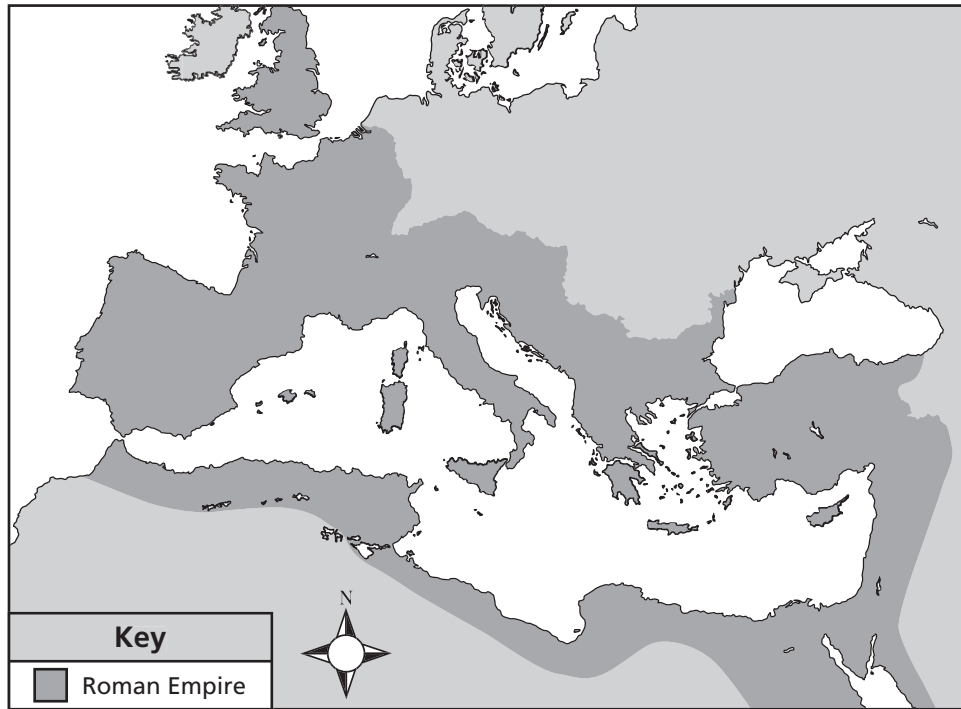

**61** Which statement is supported by the map above?

- A** Rome used its navy to conquer Europe.
- B** Rome controlled trade in the Mediterranean.
- C** Rome built a road system to conquer Africa.
- D** Rome established alliances with empires in Asia.

**62** The Renaissance changed the nature of European society by encouraging

- F** a distrust of ideas and inventions.
- G** a fear of outside influence on European culture.
- H** an increase in the role of the Church in people's lives.
- J** a greater emphasis on art and philosophy.

**63** An early technological advance that improved transportation was the development of the

- A** plow.
- B** wheel.
- C** catapult.
- D** sword.

**64** The development of writing in ancient Mesopotamia made possible the first visible

- F** legal codes.
- G** private businesses.
- H** national armies.
- J** organized religions.

**The Nile River Valley**

- Flows north into the Mediterranean Sea
- Easily traveled with sailing craft
- ?

**65** Which of these geographic factors best completes the list above?

- A** Annual flooding improved the soil
- B** Rapid currents provided waterpower
- C** Steep hillsides were well defended
- D** Dense forests provided building materials

**66** Which activity is performed by an archaeologist?

- F** examine recent events
- G** discover new diseases
- H** search for ancient tools
- J** investigate new volcanoes

**lunar** (adjective) Of or pertaining to the moon [from Latin *luna* the moon]

**67** What does the dictionary entry above best demonstrate about the development of the English language?

- A** Some English words have origins in other languages.
- B** The English alphabet is different from alphabets of other languages.
- C** English prefixes are used to create other languages.
- D** The English language has influenced other world languages.

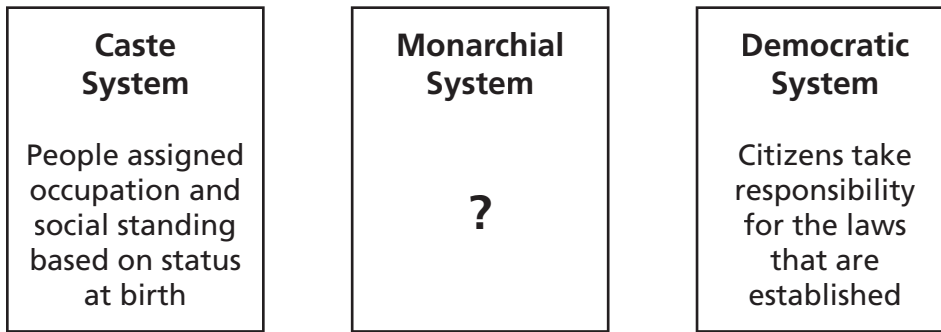

**68** Which statement best completes the diagram above?

- F** Subjects travel as missionaries
- G** Subjects obey the rulers
- H** Subjects serve as jurors in trials
- J** Subjects write the rules

**69** The microscope and thermometer were invented during the Renaissance. These inventions have the greatest impact on modern day

- A** art.
- B** medicine.
- C** law.
- D** transportation.

## Reading/Language Arts Answer Key

1	A
2	H
3	C
4	G
5	B
6	G
7	D
8	G
9	B
10	H
11	A
12	H
13	C
14	H
15	B
16	F
17	D
18	J
19	A
20	G
21	C

22	J
23	A
24	J
25	A
26	J
27	A
28	G
29	D
30	J
31	C
32	G
33	A
34	F
35	C
36	F
37	C
38	G
39	A
40	J
41	A
42	G

43	D
44	H
45	C
46	G
47	B
48	F
49	D
50	J
51	C
52	F
53	C
54	G
55	D
56	H
57	A
58	F
59	D
60	F
61	D
62	H
63	B

64	H
65	D
66	H
67	B
68	F
69	C
70	G
71	C
72	J
73	C
74	G
75	C
76	G
77	D
78	G
79	C
80	F
81	D
82	H
83	D



# Mathematics Answer Key

1	D
2	F
3	B
4	H
5	A
6	G
7	D
8	H
9	A
10	F
11	C
12	H
13	B
14	H

15	C
16	H
17	D
18	F
19	A
20	J
21	A
22	J
23	A
24	J
25	C
26	F
27	D
28	H

29	D
30	G
31	D
32	G
33	D
34	G
35	C
36	G
37	C
38	G
39	B
40	H
41	A
42	G

43	B
44	F
45	B
46	H
47	A
48	J
49	B
50	G
51	B
52	J
53	B
54	G
55	A

# Science Answer Key

1	A
2	F
3	D
4	J
5	C
6	F
7	A
8	H
9	A
10	G
11	B
12	F
13	D
14	F
15	B
16	F
17	B
18	F

19	A
20	J
21	B
22	J
23	C
24	J
25	A
26	F
27	B
28	G
29	C
30	H
31	B
32	H
33	B
34	H
35	B
36	J

37	D
38	G
39	D
40	G
41	B
42	H
43	D
44	F
45	A
46	G
47	A
48	F
49	C
50	H
51	D
52	G
53	C
54	F

55	D
56	F
57	B
58	H
59	C
60	J
61	D
62	J
63	B
64	G
65	D
66	G
67	B
68	F
69	C

## Social Studies Answer Key

1	B
2	J
3	C
4	H
5	D
6	H
7	D
8	F
9	D
10	J
11	C
12	G
13	D
14	H
15	B
16	F
17	C
18	H

19	B
20	H
21	C
22	J
23	D
24	H
25	D
26	H
27	D
28	F
29	D
30	F
31	C
32	F
33	D
34	G
35	D
36	F

37	C
38	J
39	B
40	F
41	B
42	F
43	C
44	F
45	A
46	G
47	B
48	J
49	D
50	F
51	B
52	F
53	A
54	F

55	B
56	G
57	C
58	G
59	C
60	H
61	B
62	J
63	B
64	F
65	A
66	H
67	A
68	G
69	B



# Tennessee Comprehensive Assessment Program

## Achievement Test ~ Grade 6

### Practice Test