

# Place Value

Write the word form for each number and tell the value of the underlined digit.

1. 34,235,345

**Thirty-four million, two hundred thirty-five thousand, three hundred forty-five; five thousand**

2. 19,673,890,004

**Nineteen billion, six hundred seventy-three million, eight hundred ninety thousand, four; nine billion**

3. Write 2,430,090 in expanded form.

**2,000,000 + 400,000 + 30,000 + 90**

Write each number in standard form.

4.  $80,000,000 + 4,000,000 + 100 + 8$

**84,000,108**

5. twenty-nine billion, thirty-two million

**29,032,000,000**

6. **Number Sense** What number is 10,000 less than 337,676?

**327,676**

7. Which number is 164,502,423 decreased by 100,000?

- A.** 164,402,423    **B.** 164,501,423    **C.** 164,512,423    **D.** 264,502,423

8. **Explain It** Explain how you would write 423,090,709,000 in word form.

**Start at the left and write four hundred twenty-three. Write billion for the place, ninety, million for the place, seven hundred nine, and thousand for the place**

# Comparing and Ordering Whole Numbers

Complete. Compare the numbers. Use  $<$  or  $>$  for each  $\bigcirc$ .

1. 23,412  $\bigcirc$  23,098

2. 9,000,000  $\bigcirc$  9,421,090

Order these numbers from least to greatest.

3. 7,545,999    7,445,999    7,554,000

**7,445,999    7,545,999    7,554,000**

4. **Number Sense** What digit could be in the ten millions place of a number that is less than 55,000,000 but greater than 25,000,000? **2, 3, 4, or 5**

5. Put the trenches in order from the least depth to the greatest depth.

**Kermadec Trench,**

**Philippine Trench,**

**Tonga Trench,**

**Mariana Trench**

**Depths of Major Ocean Trenches**

Trench	Depth (in feet)
Philippine Trench	32,995
Mariana Trench	35,840
Kermadec Trench	32,963
Tonga Trench	35,433

6. These numbers are ordered from greatest to least. Which number could be placed in the second position?

2,643,022    1,764,322    927,322

**A** 2,743,022    **B** 1,927,304    **C** 1,443,322    **D** 964,322

7. **Explain It** Explain why 42,678 is greater than 42,067.

**Although the digits in the thousands period are the same, the hundreds digits differ, and since 6 is greater than 0, 42,678 is the greater number.**

# Decimal Place Value

Write the word form of each number and tell the value of the underlined digit.

1. 3.100

**Three and one hundred thousandths;  
one tenth**

2. 5.267

**Five and two hundred sixty-seven  
thousandths; six hundredths**

3. 2.778

**Two and seven hundred seventy-eight  
thousandths; eight thousandths**

Write each number in standard form.

4.  $8 + 0.0 + 0.05 + 0.009 + 0.0006$

**8.0596**

5.  $1 + 0.9 + 0.08 + 0.001 + 0.00002$

**1.98102**

Write two decimals that are equivalent to the given decimal.

6. 5.300

**5.3, 5.30**

7. 3.7

**3.700, 3.7000**

8. 0.9

**0.90, 0.90000**

9. The longest stem on Eli's geranium plant is 7.24 inches. Write 7.24 in word form.

**Seven and twenty-four hundredths**

10. **Explain It** The number 4.124 has two 4s. Why does each 4 have a different value?

**The first 4 is in the ones place; the second 4 is in the thousandths place.**

# Comparing and Ordering Decimals

Write  $>$ ,  $<$ , or  $=$  for each  $\bigcirc$ .

1.  $5.424 \bigcirc 5.343$

2.  $0.33 \bigcirc 0.330$

3.  $9.489 \bigcirc 9.479$

4.  $21.012 \bigcirc 21.01$

5.  $223.21 \bigcirc 223.199$

6.  $5.43 \bigcirc 5.432$

Order these numbers from least to greatest.

7.  $8.37, 8.3, 8.219, 8.129$  **8.129, 8.219, 8.3, 8.37**

8.  $0.012, 0.100, 0.001, 0.101$  **0.001, 0.012, 0.100, 0.101**

9. **Number Sense** Name three numbers between 0.33 and 0.34.

**Sample answer: 0.334, 0.335, 0.336**

10. Which runner came in first place?

**Liz**

11. Who ran faster, Amanda or Steve?

**Amanda**

12. Who ran for the longest time?

**Steve**

Half-Mile Run

Runner	Time (minutes)
Amanda	8.016
Calvin	7.049
Liz	7.03
Steve	8.16

13. Which number is less than 28.43?

**A** 28.435

**B** 28.34

**C** 28.430

**D** 29.43

14. **Explain It** Explain why it is not reasonable to say that 4.23 is less than 4.13.

**The number 4.23 is greater than 4.13, because there is a 2 in the tenths place, and 2 is greater than 1.**

# Problem Solving: Look for a Pattern

Determine the pattern and then complete the grids.

1. 

0.87	<b>0.88</b>	0.89	<b>0.90</b>
------	-------------	------	-------------

2. 

0.12
0.22
<b>0.32</b>

3. 

0.22	0.23	<b>0.24</b>	<b>0.25</b>
------	------	-------------	-------------

4. 

0.56
<b>0.66</b>
0.76

5. **Critical Thinking** In a list of numbers, the pattern increases by 0.001 as you move to the right. If the third number in the list is 0.064, what is the first number in the list? Explain how you know.

**0.062; subtract 0.001 twice to find the first number in the list.**

6. If 5 school buses arrive, each carrying exactly 42 passengers, which expression would you use to show how many people in all arrived on the school buses?

A  $42 + 5$

B  $42 - 5$

**C**  $42 \times 5$

D  $42 \div 5$

7. **Explain It** Mishell arranged her coins in the following pattern: \$0.27, \$0.29, \$0.31, \$0.33. Explain what her pattern is, and then tell what the next amount of coins would be.

**Pattern increases by \$0.02; the next amount would be \$0.35.**

# Mental Math

Show how you can use mental math to add or subtract.

1.  $70 + 90 + 30 =$  \_\_\_\_\_

2.  $350 - 110 =$  \_\_\_\_\_

## Sample answers:

$$\begin{aligned} &70 + 90 + 30 \\ &90 + (70 + 30) \\ &90 + 100 = 190 \end{aligned}$$

$$\begin{array}{r} 350 - 110 \\ + 50 \quad + 50 \\ \downarrow \quad \downarrow \\ 400 - 160 = 240 \end{array}$$

### National Monuments

Name	State	Acres
George Washington Carver	Missouri	210
Navajo	Arizona	360
Fort Sumter	South Carolina	200
Russell Cave	Alabama	310

3. How many more acres are there at Navajo monument than at George Washington Carver monument?

**150 more acres**

4. How many acres are there at Fort Sumter and Russell Cave combined?

**510 acres**

5. Fresh Market bought 56 lb of apples in August from a local orchard. In September, the market purchased an additional 52 lb of apples and 32 lb of strawberries. How many pounds of fruit did the market buy?

A 108 lb

**B** 140 lb

C 150 lb

D 240 lb

6. **Explain It** Write the definition and give an example of the Commutative Property of Addition.

**Sample answer:**  
**The Commutative Property of Addition**  
**says you can add numbers in any order.**

$$\mathbf{30 + 15 + 2 = 15 + 30 + 2}$$

# Rounding Whole Numbers and Decimals

Round each number to the place of the underlined digit.

1. 32.60 32.6
2. 489,334,209 489,000,000
3. 324,650 325,000
4. 32.073 32.1

5. **Reasoning** Name two different numbers that round to 30 when rounded to the nearest ten.

**Sample answer: 29 and 31**

In 2000, Italy produced 7,464,000 tons of wheat, and Pakistan produced 21,079,000 tons of wheat. Round each country's wheat production in tons to the nearest hundred thousand.

6. Italy 7,500,000 tons
7. Pakistan 21,100,000 tons

The price of wheat in 1997 was \$3.38 per bushel. In 1998, the price was \$2.65 per bushel. Round the price per bushel of wheat for each year to the nearest tenth of a dollar.

8. 1997 \$3.40 per bushel
9. 1998 \$2.70 per bushel

10. **Number Sense** Which number rounds to 15,700,000 when rounded to the nearest hundred thousand?

**A** 15,000,000    **B** 15,579,999    **C** 15,649,999    **D** 15,659,999

11. **Explain It** Write a definition of rounding in your own words.

**Sample answer: Rounding helps you adjust a number to make it easier to use.**

# Estimating Sums and Differences

Sample answers are given for 1–4.

Estimate each sum or difference.

1.  $5,602 - 2,344$  3,300      2.  $7.4 + 3.1 + 9.8$  20  
 3.  $2,314 + 671$  3,000      4.  $54.23 - 2.39$  52

5. **Number Sense** Wesley estimated  $5.82 - 4.21$  to be about 2. Is this an overestimate or an underestimate? Explain.

It is an overestimate, because 5.82 was rounded up and 4.21 was rounded down.

6. Estimate the total precipitation in inches and the total number of days with precipitation for Asheville and Wichita.

**Average Yearly Precipitation of U.S. Cities**

City	Inches	Days
Asheville, North Carolina	47.71	124
Wichita, Kansas	28.61	85

About 77 in.;  
about 210 days

7. **Reasonableness** Which numbers should you add to estimate the answer to this problem:  $87,087 + 98,000$ ?

**A**  $88,000 + 98,000$

**C**  $87,000 + 98,000$

**B**  $85,000 + 95,000$

**D**  $80,000 + 90,000$

8. **Explain It** Estimate the total weight of two boxes that weigh 9.4 lb and 62.6 lb using rounding and compatible numbers. Which estimate is closer to the actual total weight? Why?

The rounded numbers are closer to the original numbers, so the rounded estimate will be closer to the actual total weight.



## Problem Solving: Draw a Picture and Write an Equation

Write two different equations; then solve each problem.

1. Dayana picked apples for 2 hours. She picked 28 apples in the first hour, and at the end of two hours, she had 49. How many apples did she pick during the second hour?

$$28 + a = 49$$

$$49 - 28 = a$$

$$\underline{21 \text{ apples}}$$

2. Dixon bought a pack of pencils and then gave 12 away. He now has 24 left. How many pencils were in the pack of pencils that Dixon bought?

$$p - 12 = 24$$

$$12 + 24 = p$$

$$\underline{36 \text{ pencils}}$$

Copy and complete the picture. Then write an equation and solve.

3. Rumina is baking 25 muffins for the bake sale. She has already baked 12. How many more does she need to bake?

25 muffins in all	
12	$n$

$$\underline{12 + n = 25; 13 \text{ muffins}}$$

4. **Estimation** Janet saved 22 dollars one month and 39 dollars the next month. She wants to buy a bicycle that costs \$100. About how much more money does she need?

**A** about \$40      **B** about \$50      **C** about \$60      **D** about \$70

5. **Explain It** Stefany ran 2 miles each day for 14 days. How many miles did she run in 14 days? Explain two different ways to solve this problem, and then solve.

**Sample: Draw a picture or write an equation; 28 miles**

# Adding and Subtracting

Add or subtract.

1. 
$$\begin{array}{r} 29,543 \\ + 13,976 \\ \hline \end{array}$$

**43,519**

2. 
$$\begin{array}{r} 93,210 \\ - 21,061 \\ \hline \end{array}$$

**72,149**

3. 
$$\begin{array}{r} 369,021 \\ - 325,310 \\ \hline \end{array}$$

**43,711**

4. 
$$\begin{array}{r} 893,887 \\ + 22,013 \\ \hline \end{array}$$

**915,900**

5.  $971,234 + 55,423 = \underline{\mathbf{1,026,657}}$

- 6.
- Number Sense**
- Is 4,000 a reasonable estimate for the difference of
- $9,215 - 5,022$
- ? Explain.

**Yes, because  $9,000 - 5,000 = 4,000$ .**

For questions 7 and 8, use the table at right.

7. How many people were employed as public officials and natural scientists?

**1,319,000 people**

8. How many more people were employed as university teachers than as lawyers and judges?

**35,000 more people****People Employed in U.S. by Occupation in 2000**

Occupation	Workers
Public officials	753,000
Natural scientists	566,000
University teachers	961,000
Lawyers and judges	926,000

9. Which is the difference between 403,951 and 135,211?

**A** 200,000**B** 221,365**C** 268,740**D** 539,162

- 10.
- Explain It**
- Issac is adding 59,029 and 55,678. Should his answer be greater than or less than 100,000? Explain how you know.

**Greater than 100,000, because an****estimate of  $60,000 + 60,000 = 120,000$**

# Adding Decimals

Add.

$$\begin{array}{r} 1. \quad 58.0 \\ + 3.6 \\ \hline \end{array}$$

**61.6**

$$\begin{array}{r} 2. \quad 40.5 \\ + 22.3 \\ \hline \end{array}$$

**62.8**

$$\begin{array}{r} 3. \quad 34.587 \\ + 21.098 \\ \hline \end{array}$$

**55.685**

$$\begin{array}{r} 4. \quad 43.1000 \\ + 8.4388 \\ \hline \end{array}$$

**51.5388**

$$5. \quad 16.036 + 7.009 = \underline{23.045}$$

$$6. \quad 92.30 + 0.32 = \underline{92.62}$$

7. **Number Sense** Reilly adds 45.3 and 3.21. Should his sum be greater than or less than 48? Tell how you know.

**The sum should be greater than 48, because the whole numbers have a sum of 48 without adding the decimals.**

In science class, students weighed different amounts of tin.

Carmen weighed 4.361 g, Kim weighed 2.704 g, Simon weighed 5.295 g, and Angelica weighed 8.537 g.

8. How many grams of tin did Carmen and Angelica have combined?

**12.898 g of tin**

9. How many grams of tin did Kim and Simon have combined?

**7.999 g of tin**

10. In December the snowfall was 0.03 in. and in January it was 2.1 in. Which was the total snowfall?

**A** 3.2 in.

**B** 2.40 in.

**C** 2.13 in.

**D** 0.03 in.

11. **Explain It** Explain why it is important to line up decimal numbers by their place value when you add or subtract them.

**Sample answer: When adding or**

**subtracting, you must always add or**

**subtract digits that have the same place value.**

Topic 2

# Subtracting Decimals

Subtract.

$$\begin{array}{r} 1. \quad 92.1 \\ - 32.6 \\ \hline \end{array}$$

**59.5**

$$\begin{array}{r} 2. \quad 52.7 \\ - 36.9 \\ \hline \end{array}$$

**15.8**

$$\begin{array}{r} 3. \quad 85.76 \\ - 12.986 \\ \hline \end{array}$$

**72.774**

$$\begin{array}{r} 4. \quad 32.7 \\ - 2.328 \\ \hline \end{array}$$

**30.372**

$$5. \quad 8.7 - 0.3 = \underline{\mathbf{8.4}}$$

$$6. \quad 23.3 - 1.32 = \underline{\mathbf{21.98}}$$

7. **Number Sense** Kelly subtracted 2.3 from 20 and got 17.7. Explain why this answer is reasonable.

**A good estimate is  $20 - 2 = 18$ , which is close to 17.7.**

At a local swim meet, the second-place swimmer of the 100-m freestyle had a time of 9.33 sec. The first-place swimmer's time was 1.32 sec faster than the second-place swimmer. The third-place time was 13.65 sec.

8. What was the time for the first-place swimmer? **8.01 sec**

9. What was the difference in time between the second- and third-place swimmers? **4.32 sec**

10. Miami's annual precipitation in 2000 was 61.05 in. Albany's was 46.92 in. How much greater was Miami's precipitation than Albany's?

A 107.97 in.    B 54.31 in.    C 14.93 in.    **D 14.13 in.**

11. **Explain It** Explain how to subtract 7.6 from 20.39.

**Sample answer: Write the numbers, lining up the decimal points. Write zeros to show place value. Subtract the hundredths, the tenths, and the ones. Place the decimal point in the answer.**

# Problem Solving: Multiple-Step Problems

Solve.

1. Theater tickets for children cost \$5. Adult tickets cost \$3 more. If 2 adults and 2 children buy theater tickets, what is the total cost?

**\$26**

2. Luis has a \$10 bill and three \$5 bills. He spends \$12.75 on the entrance fee to an amusement park and \$8.50 on snacks. How much money does he have left?

**\$3.75**

3. **Number Sense** Alexandra earns \$125 from her paper route each month, but she spends about \$20 each month on personal expenses. To pay for a school trip that costs \$800, about how many months does she need to save money? Explain.

**About 8 months, since she can save about \$100 per month**

4. **Critical Thinking** Patty is a member of the environmental club. Each weekday, she volunteers for 2 hours. On Saturday and Sunday, she volunteers 3 hours more each day. Which expression shows how to find the number of hours she volunteers in one week?

A  $2 + 5$

**B**  $2 + 2 + 2 + 2 + 2 + 5 + 5$

C  $2 + 2 + 2 + 3 + 3$

D  $2 + 3 + 3$

5. **Explain It** Marco's goal is to eat only 2,000 calories each day. One day for breakfast he consumed 310 calories, for lunch he consumed 200 more calories than breakfast, and for dinner he consumed 800. Did he make his goal? Explain.

**Yes:  $310 + 510 + 800 = 1,620$  calories.**

# Multiplication Properties

In 1 through 5, write the multiplication property used in each equation.

1.  $53 \times 6 = 6 \times 53$

commutative

2.  $0 \times 374,387 = 0$

zero

3.  $5 \times (11 \times 4) = (5 \times 11) \times 4$

associative

4.  $42 \times 1 = 42$

identity

5.  $14 \times 5 = 5 \times 14$

commutative

6. **Reasoning** Chan bought 2 large frozen yogurts at \$1.50 each and 1 small bottle of water for \$1.00. How much did she pay in total?

\$4.00

7. Dan has 4 shelves. He has exactly 10 books on each shelf. Judy has 10 shelves. She has exactly 4 books on each shelf. Who has more books? Explain.

They have the same number of books.

$4 \times 10 = 10 \times 4$

8. **Algebra** If  $3 \times 8 \times 12 = 8 \times 3 \times n$ , what is the value of  $n$ ?

A 3

B 8

 C 12

D 18

9. **Explain It** Write a definition for the Associative Property of Multiplication in your own words and explain how you would use it to compute  $4 \times 25 \times 27$  mentally.

Sample answer: Using the AssociativeProperty of Multiplication you cangroup  $(4 \times 25)$  and multiply the productby 27 to get 2,700.

# Using Mental Math to Multiply

Use mental math to find each product.

1.  $150 \times 20 =$

**3,000**

2.  $0 \times 50 \times 800 =$

**0**

3.  $500 \times 40 =$

**20,000**

4.  $120 \times 50 =$

**6,000**

5.  $60 \times 70 \times 1 =$

**4,200**

6.  $9,000 \times 80 =$

**720,000**

7.  $100 \times 10 \times 1 =$

**1,000**

8.  $1,800 \times 20 \times 0 =$

**0**

9.  $30 \times 20 =$

**600**

10.  $1,400 \times 2,000 =$

**2,800,000**

11.  $7,000 \times 50 \times 1 =$

**350,000**

12.  $1,000 \times 200 \times 30 =$

**6,000,000**

13. **Number Sense** A googol is a large number that is the digit one followed by one hundred zeros. If you multiply a googol by 100, how many zeros will that product have?

**102 zeros**

14. Gregorios drives 200 miles per day for 10 days. How many miles did he drive in all?

**2,000 miles**

15. **Algebra** If  $a \times b \times c = 0$ , and  $a$  and  $b$  are integers greater than 10, what must  $c$  equal?

**(A) 0****B 1****C 2****D 10**

16. **Explain It** SungHee empties her piggy bank and finds that she has 200 quarters, 150 dimes, and 300 pennies. How much money does she have? Explain.

 **$(200 \times 25) + (150 \times 10) + (300 \times 1) =$**  **$5,000 + 1,500 + 300 = 6,800$  cents, so****she has 68 dollars.**

# Estimating Products

Estimate each product.

1.  $68 \times 21 =$

**1,400**

2.  $5 \times 101 =$

**500**

3.  $151 \times 21 =$

**3,000**

4.  $99 \times 99 =$

**10,000**

5.  $87 \times 403 =$

**36,000**

6.  $19 \times 718 =$

**14,000**

7.  $39 \times 51 =$

**2,000**

8.  $47 \times 29 \times 11 =$

**15,000**

9.  $70 \times 27 =$

**2,100**

10.  $69 \times 21 \times 23 =$

**28,000**

11.  $7 \times 616 =$

**4,200**

12.  $8,880 \times 30 =$

**270,000**

- 13.
- Number Sense**
- Give three numbers whose product is about 9,000.

**Possible answer:  $99 \times 10 \times 9$** 

14. About how much would it cost to buy 4 CD/MP3 players and 3 MP3 players?

**About \$1,100****Electronics Prices**

CD player	\$ 74.00
MP3 player	\$ 99.00
CD/MP3 player	\$199.00
AM/FM radio	\$ 29.00

15. Which is the closest estimate for the product of
- $2 \times 19 \times 5$
- ?

A 1,150

**B 200**

C 125

D 50

- 16.
- Explain It**
- Explain how you know whether an estimate of a product is an overestimate or an underestimate.

**Sample answer: If the numbers are rounded down, it is an underestimate.****If the numbers are rounded up, it is an overestimate.**



# Multiplying by 1-Digit Numbers

Find each product. Estimate to check that your answer is reasonable.

$$1. 58 \times 3 = \underline{174} \qquad 2. 49 \times 8 = \underline{392}$$

$$3. 83 \times 5 = \underline{415} \qquad 4. 95 \times 6 = \underline{570}$$

$$5. 273 \times 4 = \underline{1,092} \qquad 6. 35 \times 8 = \underline{280}$$

$$7. 789 \times 6 = \underline{4,734} \qquad 8. 643 \times 7 = \underline{4,501}$$

$$\begin{array}{r} 9. \quad 68 \\ \quad \times 2 \\ \hline 136 \end{array}$$

$$\begin{array}{r} 10. \quad 582 \\ \quad \times 5 \\ \hline 2,910 \end{array}$$

$$\begin{array}{r} 11. \quad 84 \\ \quad \times 4 \\ \hline 336 \end{array}$$

$$\begin{array}{r} 12. \quad 926 \\ \quad \times 7 \\ \hline 6,482 \end{array}$$

13. Xavier painted five portraits and wants to sell them for 36 dollars each. How much money will he make if he sells all five? \$180

14. A farmer wants to build a square pigpen. The length of one side of the pen is 13 ft. How many feet of fencing should the farmer buy? 52 ft

15. Jasmine wants to buy 4 green bags for 18 dollars each and 3 purple bags for 15 dollars each. She has 100 dollars. How much more money does she need? \$17

16. **Geometry** A regular octagon is a figure that has eight sides with equal lengths. If one side of a regular octagon is 14 inches long, what is the perimeter of the entire octagon?

A 148 in.

B 140 in.

**C** 112 in.

D 84 in.

17. **Explain It** Why is 2,482 not a reasonable answer for  $542 \times 6$ ?

**Sample answer:  $542 \times 6$  is about 3,000; 3,000 is an underestimate, so 2,482 is not a reasonable answer.**

# Multiplying 2-Digit by 2-Digit Numbers

Find each product. Estimate to check that your answer is reasonable.

$$\begin{array}{r} 1. \quad 56 \\ \times 34 \\ \hline \end{array}$$

**1,904**

$$\begin{array}{r} 2. \quad 45 \\ \times 76 \\ \hline \end{array}$$

**3,420**

$$\begin{array}{r} 3. \quad 35 \\ \times 15 \\ \hline \end{array}$$

**525**

$$\begin{array}{r} 4. \quad 47 \\ \times 94 \\ \hline \end{array}$$

**4,418**

$$\begin{array}{r} 5. \quad 64 \\ \times 51 \\ \hline \end{array}$$

**3,264**

$$\begin{array}{r} 6. \quad 47 \\ \times 30 \\ \hline \end{array}$$

**1,410**

$$\begin{array}{r} 7. \quad 56 \\ \times 19 \\ \hline \end{array}$$

**1,064**

$$\begin{array}{r} 8. \quad 92 \\ \times 49 \\ \hline \end{array}$$

**4,508**

9. To pay for a sofa, Maddie made a payment of 64 dollars each month for one year. How much did the sofa cost ?

**\$768**

10. **Geometry** To find the volume of a box, you multiply the length times the width times the height. What is the volume, in cubic feet, of a box that is 3 ft long, 8 ft wide, and 16 ft high?

**384 cubic feet**

11. **Estimation** Katie is in charge of buying juice for the teachers' breakfast party. If one teacher will drink between 18 and 22 ounces of juice, and there are 32 teachers, which is the best estimate for the amount of juice Katie should buy?
- A about 200 ounces  
 B about 400 ounces  
 C about 600 ounces  
 D about 800 ounces

12. **Explain It** Is 7,849 a reasonable answer for  $49 \times 49$ ? Why or why not?

**Sample answer: No;  $49 \times 49$  is about**

**2,500; 2,500 is an overestimate, and**

**7,849 is not close to 2,500.**

# Multiplying Greater Numbers

Find each product. Estimate to check that your answer is reasonable.

$$\begin{array}{r} 1. \quad 556 \\ \times 34 \\ \hline \end{array}$$

**18,904**

$$\begin{array}{r} 2. \quad 234 \\ \times 75 \\ \hline \end{array}$$

**17,550**

$$\begin{array}{r} 3. \quad 395 \\ \times 76 \\ \hline \end{array}$$

**30,020**

$$\begin{array}{r} 4. \quad 483 \\ \times 57 \\ \hline \end{array}$$

**27,531**

$$\begin{array}{r} 5. \quad 628 \\ \times 33 \\ \hline \end{array}$$

**20,724**

$$\begin{array}{r} 6. \quad 154 \\ \times 35 \\ \hline \end{array}$$

**5,390**

$$\begin{array}{r} 7. \quad 643 \\ \times 49 \\ \hline \end{array}$$

**31,507**

$$\begin{array}{r} 8. \quad 536 \\ \times 94 \\ \hline \end{array}$$

**50,384**

9. **Number Sense** In a class of 24 students, 13 students sold over 150 raffle tickets each, and the rest of the class sold about 60 raffle tickets each. The class goal was to sell 2,000 tickets. Did they reach their goal? Explain.

**Sample answer: Yes;  $13 \times 150 = 1,950$**

**and the rest of the class sold more than 50, so they went over their goal of 2,000.**

10. Player A's longest home run distance is 484 ft. If Player A hits 45 home runs at his longest distance, what would the total distance be?

**21,780 feet**

11. Player B's longest home run distance is 500 ft. There are 5,280 ft in 1 mi. How many home runs would Player B need to hit at his longest distance for the total to be greater than 1 mi?

**11 home runs**

12. **Algebra** Which equation shows how you can find the number of minutes in one year?

- A**  $60 \times 24 \times 365$   
 **B**  $60 \times 60 \times 24$   
 **C**  $60 \times 365$   
 **D**  $60 \times 60 \times 365$

13. **Explain It** Write a real-world problem where you would have to multiply 120 and 75.

**Check students' work.**

# Exponents

For questions 1–4, write in exponential notation.

1.  $13 \times 13 \times 13$   $13^3$

2.  $8 \times 8 \times 8 \times 8 \times 8 \times 8$   $8^6$

3.  $64 \times 64$   $64^2$

4.  $4 \times 4 \times 4 \times 4$   
 $\times 4 \times 4 \times 4 \times 4$   $4^8$

For questions 5–8, write in expanded form.

5.  $2^5$   $2 \times 2 \times 2 \times 2 \times 2$

6. 20 squared  $20 \times 20$

7.  $11^4$   $11 \times 11 \times 11 \times 11$

8. 9 cubed  $9 \times 9 \times 9$

For questions 9–12, write in standard form.

9.  $4 \times 4 \times 4$   $64$

10. 14 squared  $196$

11.  $6^5$   $7,776$

12.  $9 \times 9 \times 9 \times 9$   $6,561$

13. **Number Sense** Which of these numbers, written in expanded form, is equal to 625?

A  $5 \times 5 \times 5 \times 5$

B  $5 \times 5$

C  $5 \times 5 \times 5$

D  $5 \times 5 \times 5 \times 5 \times 5$

14. **Number Sense** Find the number equal to 6 raised to the second power.

A 18

B 36

C 6

D 12

15. **Explain It** Explain what 4 raised to the fourth power means.

**4 raised to the fourth power means**  
**four factors of 4 multiplied together:**  
 **$4 \times 4 \times 4 \times 4$ .**

# Problem Solving: Draw a Picture and Write an Equation

Draw a picture and write an equation. Then solve.

1. When Mary was born, she weighed 8 pounds. When she was 10 years old, she weighed 10 times as much. How much did she weigh when she was 10 years old?

$$8 \times 10 = n; n = 80 \text{ lb}$$

2. Sandi is 13 years old. Karla is 3 times Sandi's age. How old is Karla?

$$13 \times 3 = n; n = 39$$

3. **Reasoning** Hwong can fit 12 packets of coffee in a small box and 50 packets of coffee in a large box. Hwong has 10 small boxes and would like to reorganize them into large boxes. Which boxes should he use? Explain.

**Since 10 small boxes is 120 packets of coffee, he can use 2 large boxes and 2 small boxes.**

4. **Number Sense** Daniel has 12 tennis balls. Manuel has twice as many tennis balls as Daniel. Kendra has twice as many balls as Manuel. How many tennis balls do they have in all?

A 24

B 36

**C 84**

D 96

5. **Explain It** William travels only on Saturdays and Sundays and has flown 400 miles this month. Jason travels every weekday and has flown 500 miles this month. Who travels more miles *per day*? Explain.

**William; he travels only two days per week but has flown almost the same number of miles this month as Jason.**

# Dividing Multiples of 10 and 100

Use mental math to find each quotient.

1.  $27 \div 9 =$

**3**

2.  $270 \div 9 =$

**30**

3.  $2,700 \div 9 =$

**300**

4.  $24 \div 4 =$

**6**

5.  $240 \div 4 =$

**60**

6.  $2,400 \div 4 =$

**600**

7.  $720 \div 9 =$

**80**

8.  $140 \div 7 =$

**20**

9.  $2,100 \div 3 =$

**700**

10. If a bike race covers 120 mi over 6 days and the cyclists ride the same distance each day, how many miles does each cyclist ride each day?

**20 mi**

Use mental math to answer the following questions.

11. If the vehicles are divided evenly between the sections, how many vehicles are in each section?

**300 vehicles**

Dealership Vehicle Storage	
Sections of vehicles .....	4
Vehicles for sale .....	1,200
Rows per section .....	10

12. If the vehicles are divided evenly between the rows in each section, how many vehicles are in each row?

**30 Vehicles**

13. **Algebra** If  $160,000 \div n = 4$ , find  $n$ .

**40,000**

14. Find  $32,000 \div 8$  mentally.

**A** 4,000**B** 400**C** 40**D** 4

15. **Explain It** Solve the equation  $n \times 50 = 5,000$ . Explain your solution.

 **$n = 100$ ; Sample answer: Divide each side by 50.**

# Estimating Quotients

Estimate each quotient. Tell which method you used.

**Sample answers  
for 1–8.**

- |                      |             |                           |
|----------------------|-------------|---------------------------|
| 1. $195 \div 4$      | <u>50</u>   | <u>Multiplication</u>     |
| 2. $283 \div 5$      | <u>60</u>   | <u>Rounding</u>           |
| 3. $766 \div 8$      | <u>90</u>   | <u>Rounding</u>           |
| 4. $179 \div 2$      | <u>90</u>   | <u>Compatible numbers</u> |
| 5. $\$395.20 \div 5$ | <u>\$80</u> | <u>Rounding</u>           |
| 6. $\$31.75 \div 8$  | <u>\$4</u>  | <u>Compatible numbers</u> |
| 7. $\$247.80 \div 5$ | <u>\$50</u> | <u>Multiplication</u>     |

8. **Reasoning** If you use  $\$63.00 \div 9$  to estimate  $\$62.59 \div 9$ , is \$7.00 greater than or less than the exact answer? Explain.

**Greater than;  $9 \times 7 = 63$ , which is greater than \$62.59.**

9. A band played 3 concerts and earned a total of \$321.00. The band earned about the same amount for each concert. Estimate how much the band earned each night.
10. At a department store, a woman's total was \$284.00 for 7 items. Estimate the average cost per item.

**About \$100 each night**

**About \$40.00**

11. Which is the closest estimate for  $213 \div 4$ ?

**A** 50

**B** 40

**C** 30

**D** 20

12. **Explain It** Explain how to estimate  $524 \div 9$ .

**Sample answer: Round 524 to 500, 9 to 10, and divide:  $500 \div 10 = 50$ .**

# Problem Solving: Reasonableness

Solve.

1. One tray holds eight sandwiches. If there are 30 sandwiches in all, how many trays are needed?

**4 trays**

2. There are 53 students on a field trip. One chaperone is needed for every 6 students. How many chaperones are needed?

**9**

Mrs. Favicchio has 72 students in her science class. The table shows how many students can use each item of lab supplies she is ordering.

Lab Supplies	
Item	Number of Students
Packet of pH paper	10
Case of test tubes	5
Case of petri dishes	4

3. How many packets of pH paper does she need to order?

**8**

4. How many cases of test tubes does she need to order?

**15**

5. **Algebra** A loaf of banana bread serves 6 guests. There will be 47 guests attending the faculty breakfast. Which expression shows how many loaves are needed to serve them all?

A 47 divided by 6 is 7 R 5, so 7 loaves are needed.

**B** 47 divided by 6 is 7 R 5, so 8 loaves are needed.

C 47 plus 6 is 53, so 53 loaves are needed.

D 47 minus 6 is 41, so 41 loaves are needed.

6. **Explain It** You are in line at an amusement park. You count 34 people in front of you. Each rollercoaster fits 11 people. How many rollercoasters must run before you can get on? Explain.

**3 rides must go by, and you will get on the fourth one.**



# Connecting Models and Symbols

After mowing lawns for one week, John put the money he earned on the table. There were four \$100 bills, three \$10 bills, and five \$1 bills.

- If John's brother borrowed one of the \$100 bills and replaced it with ten \$10 bills,
  - how many \$100 bills would there be? Three \$100 bills
  - how many \$10 bills would there be? Thirteen \$10 bills
- If John needed to divide the money evenly with two other workers, how much would each person receive? \$145
- If John needed to divide the money evenly with four other workers, how much would each person receive? \$87

Complete each division problem. You may use play money or draw diagrams to help.

4.

$$\begin{array}{r}
 \boxed{3} \boxed{4} \\
 4 \overline{) 136} \\
 \underline{- \boxed{1} \boxed{2}} \phantom{0} \\
 \phantom{0} \boxed{1} 6 \\
 \phantom{0} \underline{- \boxed{1} \boxed{6}} \\
 \phantom{00} \boxed{0}
 \end{array}$$

5.

$$\begin{array}{r}
 \boxed{5} \boxed{4} \\
 3 \overline{) 162} \\
 \underline{- \boxed{1} \boxed{5}} \phantom{0} \\
 \phantom{0} \boxed{1} 2 \\
 \phantom{0} \underline{- \boxed{1} \boxed{2}} \\
 \phantom{00} \boxed{0}
 \end{array}$$

6. If \$644.00 is divided equally among 7 people, how much will each person receive?
- A \$82.00      **B** \$92.00      C \$93.00      D \$103.00

7. **Explain It** Write a story problem using two \$100 bills, nine \$10 bills, and seven \$1 bills.

**Sample answer: Karl borrowed \$297 from his sister. He pays her \$33 each week. How many weeks will it take Karl to pay \$297?**

# Dividing by 1-Digit Divisors

Find each quotient.

1.  $\overset{293}{2}\overline{)586}$

2.  $\overset{188\text{ R}1}{3}\overline{)565}$

3.  $\overset{143\text{ R}3}{5}\overline{)718}$

4.  $\overset{149\text{ R}3}{4}\overline{)599}$

5.  $\overset{128\text{ R}2}{5}\overline{)642}$

6.  $\overset{59}{6}\overline{)354}$

7.  $\overset{23\text{ R}3}{9}\overline{)210}$

8.  $\overset{115\text{ R}7}{8}\overline{)927}$

The Paez family lives in Louisville, Kentucky, and has decided to take a road trip for their summer vacation.

9. How many miles will the Paez family drive each day if they decide to take 5 days to drive 865 mi to Dallas?

173 mi each day

10. The Paez family decides they want to drive 996 mi to Boston in 6 days. How many miles will they drive each day?

166 mi

11. **Reasonableness** If a staff of 9 people had to clean a hotel with 198 rooms, how many rooms would each person have to clean if they divided the rooms equally?

A 29

B 25

C 23

**D 22**

12. **Explain It** Explain how to check the quotient from a division problem.

Sample answer: You need to multiply the quotient by the divisor and then add the remainder. This should equal the dividend.

# Zeros in the Quotient

Find each quotient. Check your answers by multiplying.

1.  $490 \div 7 = \underline{70}$

2.  $326 \div 3 = \underline{108 \text{ R}2}$

3.  $916 \div 3 = \underline{305 \text{ R}1}$

4.  $720 \div 2 = \underline{360}$

5.  $2 \overline{)941} \quad \underline{470 \text{ R}1}$

6.  $9 \overline{)982} \quad \underline{109 \text{ R}1}$

7.  $7 \overline{)740} \quad \underline{105 \text{ R}5}$

8.  $5 \overline{)703} \quad \underline{140 \text{ R}3}$

9. If there are 505 seats in an auditorium divided equally into 5 sections, how many seats are in each section? **101 seats**

10. A book company publishes 749 copies of a novel and distributes them to 7 bookstores. If each bookstore were to receive the same number of copies, how many copies would be sent to each store?

**107 copies**

11. In one year, Dolores and Tom's four children saved \$420 by recycling cans. When they divided the money equally, how much money did each child receive?

**A** \$50

**B** \$100

**C** \$105

**D** \$1,500

12. **Explain It** Explain why estimating before you divide  $624 \div 6$  helps you place the first digit in the quotient.

**Sample answer: By estimating you**

**will know if the answer will be in the**

**hundreds, tens, or ones.**

# Understanding Factors

List all the factors of each number.

1. 36      1, 2, 3, 4, 6, 9, 12, 18, 36
2. 90      1, 2, 3, 5, 6, 9, 10, 15, 18, 30, 45, 90
3. 84      1, 2, 3, 4, 6, 7, 12, 14, 21, 28, 42, 84

**Number Sense** A number is divisible by 4 if the last two digits are divisible by 4. Write yes on the line if the number is divisible by 4 and no if it is not.

4. 324      Yes      5. 634      No      6. 172      Yes

7. A class of 80 students is graduating from elementary school. The teachers need help figuring out how to line up the students for the ceremony. One row of 80 students would be too long. What other ways could the students be arranged for the ceremony?

2 rows of 40, 4 rows of 20, 5 rows of 16,  
8 rows of 10

8. A number is divisible by another number when the remainder after division by that number is 0.
9. **Number Sense** What factor pair is missing for 45 if you already know 1 and 45, 5 and 9?
- A 7 and 6      B 8 and 6      **C 3 and 15**      D. 4 and 12

10. **Explain It** Explain how to find all the factor pairs of 40.

Sample answer: Follow the rules for  
divisibility of 2, 3, 4, 5, 6, 9, and 10, and  
check if the number is divisible by  
7 and 8.

# Prime and Composite Numbers

Write whether each number is prime or composite.

1. 21 Composite    2. 36 Composite    3. 31 Prime

4. 87 Composite    5. 62 Composite    6. 23 Prime

Use factor trees to find the prime factorization of each number.

7. 44  $2 \times 2 \times 11$     8. 63  $3 \times 3 \times 7$

9. 13  $1 \times 13$     10. 54  $2 \times 3 \times 3 \times 3$

11. **Number Sense** Audrey says that the prime factorization of 42 is  $21 \times 2$ . Is she correct? If not, tell why.

**Sample answer: Audrey is not correct. Since 21 can be divided by 7 or 3, 21 is not prime.**

12. Is 4,564,282 prime or composite? Explain how you determined your answer.

**Composite; It ends with an even number, so it is divisible by 2.**

13. Which of the following is a prime number?

A 105

B 27

**C 19**

D 9

14. **Explain It** Does it matter what two factors you select to complete a factor tree? Explain.

**No; the prime factors will always end up at the bottom of the tree.**

# Problem Solving: Draw a Picture and Write an Equation

Draw a picture and write an equation. Then solve.

1. Tommy paid \$39 to fill up the gas tank in his car. If one gallon of gas costs \$3, how many gallons of gas did Tommy put in?

**Check students' diagrams.  $39 \div 3 =$**

**$g$ ;  $g = 13$ ; 13 gallons of gas**

2. To prepare for the brunch, Ivana needs to place 8 muffins in each basket. If she has 115 muffins, how many baskets will she need?

**Check students' diagrams.  $115 \div 8 =$**

**$b$ ;  $b = 14 \text{ R } 3$ ; 15 baskets**

3. **Write a Problem** Write a real-world problem that you can solve by writing an equation. The answer to the problem must be 6.

**Answer will vary. Check students' work.**

4. **Geometry** The perimeter is the distance around an object. The perimeter of a square is 84 centimeters. What is the length of one side of the square?

A 75 cm

B 42 cm

**C** 21 cm

D 14 cm

5. **Explain It** A perfect score on a quiz is 100. Mrs. Frisoli gives students 1 point for putting their name on the paper. If there are only 9 questions on the quiz, how much is each question worth? Explain how you found your answer.

**$100 - 1 = 99$ .  $99 \div 9 = 11$ . Each question is worth 11 points.**

# Using Patterns to Divide

In 1 through 4, find each quotient. Use mental math.

1.  $360 \div 40 = 36 \text{ tens} \div 4 \text{ tens} = \underline{9}$

2.  $5,400 \div 90 = 540 \text{ tens} \div 9 \text{ tens} = \underline{60}$

3.  $240 \div 30 = 24 \text{ tens} \div 3 \text{ tens} = \underline{8}$

4.  $4,800 \div 10 = 480 \text{ tens} \div 1 \text{ ten} = \underline{480}$

Use mental math to answer the following questions.

5. If the vehicles are divided evenly among the sections, how many vehicles are in each section?

**300 vehicles**

Dealership Vehicle Storage	
Sections of vehicles	4
Vehicles for sale	1,200
Rows per section	10

6. If the vehicles are divided evenly among the rows in each section, how many vehicles are in each row?

**30 vehicles**

7. **Estimation** Suppose there are 297 students going on a field trip. If each schoolbus can carry 58 students, estimate the number of buses that will be needed to transport all the students.

**Since  $\frac{300}{60} = 5$ , about 5 school buses will be needed.**

8. **Algebra** If  $160,000 \div n = 4$ , what is the value of  $n$ ?

A 40

B 400

C 4,000

**(D) 40,000**

9. **Explain It** Solve the equation  $n \times 50 = 5,000$ . Explain your solution.

**$n = 100$ ; Sample answer: Divide each side by 50.**

# Estimating Quotients with 2-Digit Divisors

In 1 through 4, estimate the quotients using compatible numbers.

1.  $566 \div 81 =$  7                      2.  $453 \div 93 =$  5

3.  $1,423 \div 69 =$  20                      4.  $8,631 \div 10 =$  860

5. **Reasoning** If you use  $\$99.00 \div 11$  to estimate  $\$98.69 \div 11$ , is \$9.00 greater than or less than the exact answer? Explain.

**Greater than; Sample answer:  $11 \times 9 = 99$ , which is greater than \$98.69.**

6. Suppose there are 19 students in a class. A teacher has 122 pencils and passes them out to the class. Estimate the number of pencils each student will receive. 6

7. At a department store, a package of 12 handkerchiefs costs \$58.99. Estimate how much each handkerchief costs. \$5

8. **Number Sense** Which is the closest estimate for  $2,130 \div 33$ ?  
A 7                      B 17                      **C 70**                      D 700

9. **Explain It** Explain how to estimate  $498 \div 12$ .

**Sample answer: Use compatible numbers:  $500 \div 10 = 50$ .**



# Problem Solving: Multiple-Step Problems

Write and answer the hidden question. Then solve.

1. Gloria talked on her cell phone for 320 minutes the first month, 243 minutes the second month, and 489 minutes the third month. Her payment package does not allow her to pay per minute; she can only buy packages. If she has to pay \$25 for every 200 minutes, how much did she pay for the first three months?

**How many total minutes did she use for the first 3 months? (1,052) How many “200 minute” packages did she use? (6); She had to pay \$150 for the first three months.**

2. Each can of paint will cover 450 tiles. Augustin is painting 300 tiles in his bathroom, 675 in his kitchen, and 100 in his hallway. How many cans of paint does he need to buy?

**How many total tiles is Augustin painting? (1,075) He will need to buy 3 cans of paint.**

3. **Number Sense** The sum of three different numbers is 18. If every number is a prime number, what are the three numbers?

**What prime numbers are less than 18? (2, 3, 5, 7, 11, 13, 17); 2, 5, and 11 or 2, 3, and 13.**

4. **Explain It** You earn \$3 an hour as a waitress. After working 3 hours, you earn \$12, \$5, and \$7 in tips. How much money did you earn in total? Explain how you found your answer.

**$3 \times 3 = 9$ , and  $12 + 5 + 7 = 24$ , so you earned \$33 total.**

# Dividing by Multiples of 10

In 1 through 6, divide.

- |                         |               |                         |              |
|-------------------------|---------------|-------------------------|--------------|
| 1. $20 \overline{)467}$ | <b>23 R7</b>  | 2. $40 \overline{)321}$ | <b>8 R1</b>  |
| 3. $80 \overline{)813}$ | <b>10 R13</b> | 4. $40 \overline{)284}$ | <b>7 R4</b>  |
| 5. $90 \overline{)648}$ | <b>7 R18</b>  | 6. $10 \overline{)587}$ | <b>58 R7</b> |

7. To drive from New York City, NY, to Los Angeles, CA, you must drive about 2,779 miles. If you drive 60 miles per hour without stopping, about how many hours do you have to drive?

**About 46 hours**

8. **Reasoning** Suppose one bottle of paint can cover 20 tiles. You have 348 tiles. How many bottles of paint do you need to buy to cover all 348 tiles? Explain.

**18 bottles; Sample answer: You must buy whole bottles and paint all tiles.**

9. A group of 483 students is taking a field trip. One bus is needed for every 50 students. How many buses are needed?

**10 buses**

10. **Geometry** A decagon is a ten-sided figure. If a decagon has a perimeter of 114 centimeters, how long is each side of the figure?

**A** 11.4 cm      **B** 14 cm      **C** 114 cm      **D** 124 cm

11. **Explain It** To figure out how many hours it will take to drive from his home to his cousin's house, a student divides 289 by 60 and estimates that it will take about 4.5 hours. Explain whether you think this is a reasonable estimate.

**Sample answer: yes, because  $60 \times 4 = 240$ , and  $60 \times 5 = 300$ . Since 289 is between 240 and 300, 4.5 is a good estimate.**

# 1-Digit Quotients

In 1 through 6, find each quotient.

1. 
$$\begin{array}{r} 3 \text{ R}9 \\ 37 \overline{)120} \end{array}$$

2. 
$$\begin{array}{r} 8 \text{ R}30 \\ 39 \overline{)342} \end{array}$$

3. 
$$\begin{array}{r} 5 \text{ R}28 \\ 62 \overline{)338} \end{array}$$

4. 
$$\begin{array}{r} 6 \text{ R}32 \\ 42 \overline{)284} \end{array}$$

5. 
$$\begin{array}{r} 7 \text{ R}25 \\ 82 \overline{)599} \end{array}$$

6. 
$$\begin{array}{r} 8 \text{ R}34 \\ 55 \overline{)474} \end{array}$$

7. Solomon has \$118. He wants to purchase concert tickets for himself and 5 friends. Each ticket costs \$19. Does he have enough money? Explain.

**Yes:  $118 \div 19 = 6 \text{ R}4$ , so he has enough money to buy 6 tickets.**

8. **Number Sense** Which problem will have the greater quotient,  $376.0 \div 93$  OR  $376 \div 93.01$ ? Explain how you know.

**$376.0 \div 93$ ; Sample answer: The same number, 376, is divided by a smaller divisor.**

9. Which is  $458 \div 73$ ?

A 5 R19

B 5 R20

C 6 R19

**D 6 R20**

10. **Explain It** A student solves the problem  $354 \div 24$ . The student finds an answer of 13 R40. Explain how you can tell that the answer is incorrect just by looking at the remainder.

**Sample answer: The remainder of 40 is greater than the divisor of 24, so an error must have been made.**

## 2-Digit Quotients

In 1 through 6, find each quotient.

1.  $14 \overline{)413}$       29 R7      2.  $29 \overline{)634}$       21 R25

3.  $35 \overline{)768}$       21 R33      4.  $19 \overline{)401}$       21 R2

5.  $45 \overline{)942}$       20 R42      6.  $26 \overline{)503}$       19 R9

7. **Reasoning** The school student council sponsored a Switch Day where students were able to switch classes every 20 minutes. The students are in school for 7 hours. If a student switched as often as possible, how many times did that student get to visit another classroom? (Hint: There are 60 minutes in 1 hour.)

**21 times**

8. 456 students participated in Switch Day. The students raised money for charity so that the principal would approve of the day. If the total amount of money raised was \$912, and each student brought in the same amount of money, how much did each student raise?

**\$2.00**

9. **Estimation** The total dinner bill at a buffet came out to \$589 for 31 people. About how much was the buffet cost per person?

A \$15.00      **B** \$20.00      C \$22.00      D \$25.00

10. **Explain It** If you have a two-digit divisor and a three-digit dividend, does the quotient always have the same number of digits?

**Sample answer: No, the quotient can have one or two digits.**

# Estimating and Dividing with Greater Numbers

Estimate first. Then use a calculator to find the quotient. Round to the nearest hundredth if necessary.

$$1. \begin{array}{r} 119.32 \\ 53 \overline{)6,324} \end{array} \quad 2. \begin{array}{r} 122.08 \\ 52 \overline{)6,348} \end{array} \quad 3. \begin{array}{r} 364.06 \\ 86 \overline{)31,309} \end{array} \quad 4. \begin{array}{r} 104.70 \\ 33 \overline{)3,455} \end{array}$$

$$5. 17,496 \div 91 = \underline{192.26} \quad 6. 25,214 \div 47 = \underline{536.47}$$

$$7. 2,312 \div 26 = \underline{88.92} \quad 8. 4,895 \div 83 = \underline{58.98}$$

The Humphrey family decided to fly from San Francisco to New York City, and from there to Rome, New Delhi, and finally Tokyo.

9. It took the Humphrey family 6 hours to travel from San Francisco to New York. How many kilometers did they travel per hour?

**690 km per hour**

### Distances by Plane

San Francisco to New York	4,140 km
New York to Rome	6,907 km
Rome to New Delhi	5,929 km
New Delhi to Tokyo	5,857 km

10. During the flight from New Delhi to Tokyo, flight attendants came through with snacks every 600 km. How many times did they come through?

**9 times**

11. **Reasoning** Use the data from Exercises 9 and 10. When the family arrived in New Delhi from Rome, the youngest son asked the pilot how fast he was flying the plane. The pilot told him about 847 km per hour. How many hours did it take the family to fly from Rome to New Delhi?

A 5 h

B 6 h

**C 7 h**

D 8 h

12. **Explain It** Write a word problem that would require you to use  $5,621 \div 23$ .

**Check students' problems.**

# Problem Solving: Missing or Extra Information

Decide if each problem has extra or missing information.  
Solve if possible.

1. It takes 4 hours to drive from Boston to New York. Jordan has a meeting in New York at 2:00 P.M. Can she arrive at her meeting on time?

**Missing information about where Jordan is and when she is leaving for the meeting.**

2. Franco hikes 4 miles each day for 5 days. He carries 100 ounces of water with him. It takes him 1 hour to hike 4 miles. How many hours did he hike in 5 days?

**He hikes 5 hours. Extra information: how much water he carries with him**

3. **Write a Problem** Write a real-world problem that gives extra information. Under the problem write what the extra information is.

**Check students' work. Answers will vary.**

4. **Critical Thinking** Jorge buys T-shirts for \$4 each and paints designs on them. He sells the designed T-shirts for \$7 each. What information is needed to find how much profit he makes in one week?

- A The price of T-shirts at a store
- B The color of the T-shirts that he buys
- C The types of designs he draws on the T-shirts
- D The number of T-shirts he sells in one week

5. **Explain It** Krista can type 60 words per minute. She wrote an essay by hand in 5 hours, and it is now 4 pages long and has 500 words in it. She wants to type up her essay. About how long will it take to type her essay? Write what the extra or missing information is. Then solve if possible.

**Extra info: Wrote it in 5 hours and is 4 pages long. It will take her between 8 and 9 minutes to type her essay.**

# Variables and Expressions

For questions 1 through 4, use a variable to write an algebraic expression that represents the word phrase.

- a number of apples divided into 12 baskets  $n \div 12$  or  $\frac{n}{12}$
- 5 more than  $s$   $s + 5$
- three times the cost for one hat  $3 \times h$  or  $3h$
- nine fewer than the total number of people  $t - 9$

For 5 through 7, translate each algebraic expression into words.

- $3 + w$  Three plus a number  $w$
- $8x$  Eight times a number  $x$
- $40 - p$   $p$  less than 40

8. Write two different word phrases for the expression  $\frac{t}{30}$ .

Samples: A number  $t$  divided by 30,  
a number  $t$  times  $\frac{1}{30}$ , 30 equal parts of  $t$

9. **Number Sense** Do  $5 + x$  and  $x + 5$  represent the same expression? Explain.

Yes, because of the Commutative  
Property of Addition

10. **Algebra** Dan is 12 in. taller than Jay. Use  $x$  for Jay's height. Which expression shows Dan's height?

**A**  $x + 12$

**B**  $x - 12$

**C**  $12x$

**D**  $\frac{x}{12}$

11. **Explain It** Explain what the expression  $6x$  means.

Sample: A number  $x$  multiplied by 6

# Patterns and Expressions

In 1 through 4, evaluate each expression for  $n = 3$  and  $n = 8$ .

1.  $n + 10$

**13; 18**

2.  $\frac{24}{n}$

**8; 3**

3.  $n \times 5$

**15; 40**

4.  $36 - n$

**33; 28**

Complete each table.

5.

$n$	$0.9 + n$
0.5	<b>1.4</b>
0.2	<b>1.1</b>
0.15	<b>1.05</b>
0.1	<b>1.0</b>

6.

$n$	$96 \div n$
1	<b>96</b>
2	<b>48</b>
3	<b>32</b>
4	<b>24</b>

7. **Write a Problem** Write a situation that can be represented by the algebraic expression  $\$3.50t$ .

**Check students' work.**

8. **Algebra** If  $a = 10$ , which of the following is the correct solution for  $a \times 0.1$ ?

A 0.01

B 0.1

**C 1**

D 10

9. **Explain It** Write one numerical expression and one algebraic expression. Then explain what the difference between a numerical and algebraic expression is.

**Check students' work. An algebraic expression has a variable.**



# More Patterns and Expressions

1. Write an algebraic expression to represent the cost of a concert ticket,  $h$ , with a service charge of \$6.75.

$$h + \$6.75$$

2. Write an algebraic expression to represent the cost of  $m$  gallons of gasoline if each gallon costs \$1.45.

$$m \times \$1.45 \text{ or } \$1.45m$$

Evaluate each expression for  $n = 3$  and  $n = 6$ .

3.  $0.2 \times n$     0.6    1.2

4.  $n - 2.1$     0.9    3.9

5.  $\frac{12}{n}$     4    2

6.  $35 + n$     38    41

Complete each table.

7.

$n$	$0.7 + n$
0.5	<b>1.2</b>
0.2	<b>.9</b>
0.15	<b>.85</b>
0.1	<b>.8</b>

8.

$n$	$60 \div n$
1	<b>60</b>
2	<b>30</b>
3	<b>20</b>
4	<b>15</b>

9. **Explain It** What is another way to write the expression  $44n$ ?  
What is another way to write the expression  $44 \div n$ ?

$$44 \times n; \frac{44}{n}$$

10. Which is the correct product of  $n \times 7$  if  $n = \$0.25$ ?

A \$3.25    B \$2.75    C \$2.25    **D** \$1.75

11. **Write a Problem** Write a situation that can be represented by the algebraic expression  $\$3.25d$ .

**Sample answer: Keri buys  $d$  candles at \$3.25 each.**

# Distributive Property

Use the Distributive Property to multiply mentally.

$$1. 5 \times 607 = \underline{3,035} \qquad 2. 16 \times 102 = \underline{1,632}$$

$$3. 7 \times 420 = \underline{2,940} \qquad 4. 265 \times 5 = \underline{1,325}$$

$$5. 44 \times 60 = \underline{2,640} \qquad 6. 220 \times 19 = \underline{4,180}$$

$$7. 45 \times 280 = \underline{12,600} \qquad 8. 341 \times 32 = \underline{10,912}$$

9. **Number Sense** Fill in the blanks to show how the Distributive Property can be used to find  $10 \times 147$ .

$$10 \times (150 - 3) = (10 \times 150) - (\underline{10} \times 3) =$$

$$1,500 - \underline{30} = \underline{1,470}$$

10. In 1990, there were 1,133 tornadoes in the U.S. If there were the same number of tornadoes for 10 years in a row, what would be the 10-year total?

11,330

11. There were 1,071 tornadoes in the U.S. in 2000. What is the number of tornadoes multiplied by 20?

21,420

12. If  $4 \times 312 = 4 \times 300 + n$ , which is the value of  $n$ ?

A 4      B 12      **C 48**      D 300

13. **Explain It** Margaret said that she used the Distributive Property to solve  $4 \times 444$ . Is her answer shown below correct? Explain.

$$4 \times 444 = 4 \times (400 + 40 + 4) =$$

$$(4 \times 400) + (4 \times 40) + (4 \times 4) =$$

$$1,600 + 160 + 16 = 1,776$$

Margaret correctly used the Distributive Property to solve  $4 \times 444$ .

# Order of Operations

Use the order of operations to evaluate each expression.

1.  $4 \times 4 + 3 =$  19      2.  $3 + 6 \times 2 \div 3 =$  7

3.  $24 - (8 \div 2) + 6 =$  26      4.  $(15 - 11) \times (25 \div 5) =$  20

5.  $26 - 4 \times 5 + 2 =$  8      6.  $15 \times (7 - 7) + (5 \times 2) =$  10

7.  $(8 \div 4) \times (7 \times 0) =$  0      8.  $5 \times (6 - 3) + 10 \div (8 - 3) =$  17

9. **Explain It** Which is a true statement,  $5 \times 4 + 1 = 25$  or  $3 + 7 \times 2 = 17$ ? Explain your answer.

$3 + 7 \times 2 = 3 + (7 \times 2) = 17;$

$5 \times 4 + 1 = (5 \times 4) + 1 = 21$

Insert parentheses to make each statement true.

10.  $25 \div 5 - 4 = 25$        $25 \div (5 - 4) = 25$

11.  $7 \times 4 - 4 \div 2 = 26$        $7 \times 4 - (4 \div 2) = 26$

12.  $3 + 5 \times 2 - 10 = 6$        $(3 + 5) \times 2 - 10 = 6$

13. **Strategy Practice** Insert parentheses in the expression  $6 + 10 \times 2$  so that:

a. the expression equals 32.       $(6 + 10) \times 2$

b. the expression equals  $(12 + 1) \times 2$ .       $6 + (10 \times 2)$

14. Solve
- $(25 - 7) \times 2 \div 4 + 2$
- .

A 18      **(B) 11**      C 6      D 5

15. Write two order-of-operation problems. Then trade with a classmate and solve the problems.

Sample answers:  $2 \times 6 + 3 - (8 \div 8); 14;$

$(9 + 20) - (24 \div 2) - 6; 11$

## Problem Solving: Act It Out and Use Reasoning

1. Christina collects stamps. She has 47 stamps in all. She has 20 stamps from Europe. The number of African stamps is 2 times the number of Asian stamps. How many stamps from each of these three continents does she have?

**20 European, 18 African, 9 Asian**

2. **Write a Problem** Write a problem that can be solved by acting it out and using reasoning.

**Answers will vary.**

\_\_\_\_\_

\_\_\_\_\_

3. A public pool opened for the summer. A total of 246 people came swimming over the first 3 days it was open. On the first day, 79 came to swim. On the second day, 104 people swam. How many people swam on the third day?

**63**

4. Marissa earned \$480 in the summer. If she earned \$40 a week, how many weeks did she work?

A 48

**B 12**

C 10

D 9

5. **Explain It** How could you use cubes to act out a problem?

**Sample answer: You can count out the total number of cubes in the word problem and then divide them up according to the problem to help you figure out the numbers.**

# Multiplying Decimals by 10, 100, or 1,000

Use mental math to find each product.

1.  $53.7 \times 10$  537
2.  $74.3 \times 100$  7,430
3.  $66.37 \times 1,000$  66,370
4.  $1.03 \times 10$  10.3
5.  $92.5 \times 10$  925
6.  $0.8352 \times 100$  83.52
7.  $0.567 \times 100$  56.7
8.  $572.6 \times 1,000$  572,600
9.  $5.8 \times 100$  580
10.  $0.21 \times 1,000$  210
11.  $6.2 \times 1,000$  6,200
12.  $1.02 \times 10$  10.2
13.  $0.003 \times 1,000$  3
14.  $0.002 \times 10$  .02
15.  $7.03 \times 10$  70.3
16.  $4.06 \times 100$  406

17. **Algebra** Kendra bought 10 gallons of gasoline at \$3.26 per gallon. How much did she pay for the gasoline?

A \$326.00    **B** \$32.60    C \$1.26    D \$0.26

18. **Strategy Practice** Freddy is helping buy ingredients for salads for the school spaghetti dinner. He bought 10 pounds of onions at \$0.69 per pound, 100 pounds of tomatoes at \$0.99 per pound, 1,000 pounds of bread crumbs at \$0.09 per pound, and 100 pounds of lettuce at \$0.69 per pound. Which of the items he bought cost the most?

**A** tomatoes    B lettuce    C bread crumbs    D onions

19. **Explain It** Marco and Suzi each multiplied  $0.721 \times 100$ . Marco got 7.21 for his product. Suzi got 72.1 for her product. Which student multiplied correctly? How do you know?

**Suzi's answer was correct. She moved the decimal the correct number of spaces to the right.**

# Multiplying a Decimal by a Whole Number

Find each product.

$$\begin{array}{r} 1. \quad 5.4 \\ \times 3 \\ \hline 16.2 \end{array}$$

$$\begin{array}{r} 2. \quad 3.8 \\ \times 4 \\ \hline 15.2 \end{array}$$

$$\begin{array}{r} 3. \quad 0.55 \\ \times 8 \\ \hline 4.4 \end{array}$$

$$\begin{array}{r} 4. \quad 8.19 \\ \times 5 \\ \hline 40.95 \end{array}$$

Insert a decimal point in each answer to make the equation true.

$$5. \quad 5 \times 6.3 = 315 \underline{31.5}$$

$$6. \quad 3.001 \times 9 = 27009 \underline{27.009}$$

Use the table at the right for Exercises 7–9.

7. Which desert accumulates the least amount of rain in August?

**Mojave**

8. If each month in Reno had the same average rainfall as in August, what would the total number of millimeters be after 12 months?

**2.28 mm**

**Average Desert Rainfall in August**

Desert	Average Rainfall
Reno	0.19 mm
Sahara	0.17 mm
Mojave	0.1 mm
Tempe	0.24 mm

9. **Explain It** In December, the average total rainfall in all of the deserts together is 0.89 mm. Explain how to use the figures from the table to write a comparison of the total desert rainfall in August and December.

**In December, the average rainfall is greater than in August, because  $0.89 \text{ mm} > 0.7 \text{ mm}$ .**

10. **Algebra** If  $4n = 3.60$ , which is the value of  $n$ ?

A 0.09

**B 0.9**

C 9

D 90

# Estimating the Product of a Decimal and a Whole Number

Estimate each product using rounding or compatible numbers.

1.  $0.97 \times 312$

300

2.  $8.02 \times 70$

560

3.  $31.04 \times 300$

9,000

4.  $0.56 \times 48$

25

5.  $0.33 \times 104$

30

6.  $0.83 \times 12$

10

7.  $0.89 \times 51$

50

8.  $4.05 \times 11$

44

9.  $0.13 \times 7$

0.7

10.  $45.1 \times 5$

225

11.  $99.3 \times 92$

9,000

12.  $47.2 \times 93$

4,500

13. **Critical Thinking** Mr. Webster works 4 days a week at his office and 1 day a week at home. The distance to Mr. Webster's office is 23.7 miles. He takes a different route home, which is 21.8 miles. When Mr. Webster works at home, he drives to the post office once a day, which is 2.3 miles from his house. Which piece of information is not important in figuring out how many miles Mr. Webster drives per week to his office?

- A the number of days at the office
- B the distance to his office
- C the distance to the post office
- D the distance from his office

14. **Strategy Practice** Mrs. Smith bought her three children new snowsuits for winter. Each snowsuit cost \$25.99. How much did Mrs. Smith pay in all?

- A \$259.90     B \$77.97    C \$51.98    D \$25.99

15. **Explain It** How can estimating be helpful before finding an actual product?

**If your estimate is very different from your actual product, you know that you need to check your work.**

# Multiplying Two Decimals

Find each product.

$$\begin{array}{r} 1. \quad 3.7 \\ \times 0.3 \\ \hline 1.11 \end{array}$$

$$\begin{array}{r} 2. \quad 4.4 \\ \times 0.2 \\ \hline 0.88 \end{array}$$

$$\begin{array}{r} 3. \quad 0.61 \\ \times 6.8 \\ \hline 4.148 \end{array}$$

$$\begin{array}{r} 4. \quad 1.9 \\ \times 0.005 \\ \hline 0.0095 \end{array}$$

$$5. \quad 0.79 \times 4.3 = \underline{3.397}$$

$$6. \quad 0.79 \times 0.005 = \underline{0.00395}$$

7. **Number Sense** The product of 4.7 and 6.5 equals 30.55. What is the product of 4.7 and 0.65? 4.7 and 65?

**3.055, 305.5**

8. What would be the gravity in relation to Earth of a planet with 3.4 times the gravity of Mercury?

**1.326**

9. The gravity of Venus is 0.35 times that of Jupiter. What is the gravity of Venus in relation to Earth's gravity?

**0.91**

**Relative (to Earth)  
Surface Gravity**

Planet	Gravity
Mercury	0.39
Neptune	1.22
Jupiter	2.6

10. How many decimal places are in the product of a number with decimal places to the thousandths multiplied by a number with decimal places to the hundredths?

A 2

B 3

C 4

**D 5**

11. **Explain It** Explain how you know the number of decimal places that should be in the product when you multiply two decimal numbers together.

**The total number of decimal places**

**in the numbers being multiplied is**

**the number of decimal places in the**

**product.**



# Dividing Decimals by 10, 100, or 1,000

Find each quotient. Use mental math.

- |                          |                |                       |                |
|--------------------------|----------------|-----------------------|----------------|
| 1. $86.6 \div 10 =$      | <u>8.66</u>    | 2. $192.5 \div 100 =$ | <u>1.925</u>   |
| 3. $1.99 \div 100 =$     | <u>0.0199</u>  | 4. $0.87 \div 10 =$   | <u>0.087</u>   |
| 5. $228.55 \div 1,000 =$ | <u>0.22855</u> | 6. $0.834 \div 100 =$ | <u>0.00834</u> |
| 7. $943.35 \div 1,000 =$ | <u>0.94335</u> | 8. $1.25 \div 10 =$   | <u>0.125</u>   |

**Algebra** Write 10, 100, or 1,000 for each  $n$ .

9.  $78.34 \div n = 0.7834$     10.  $0.32 \div n = 0.032$     11.  $(75.34 - 25.34) \div n = 5$   
 $n = 100$                        $n = 10$                        $n = 10$

12. There are 145 children taking swimming lessons at the pool. If 10 children will be assigned to each instructor, how many instructors need to be hired?

15 instructors

13. Ronald ran 534.3 mi in 100 days. If he ran an equal distance each day, how many miles did he run per day?

**A** 5                      **B** 5.13                      **C** 5.343                      **D** 6.201

14. **Explain It** Carlos says that  $17.43 \div 100$  is the same as  $174.3 \times 0.01$ . Is he correct? Explain.

No, he is not correct.  $17.43 \div 100$  is  $0.1743$  and  $174.3 \times 0.01$  is  $1.743$ .

# Dividing a Decimal by a Whole Number

Find each quotient.

$$1. \begin{array}{r} 5.3 \\ 13 \overline{)68.9} \end{array}$$

$$2. \begin{array}{r} 11.78 \\ 35 \overline{)412.3} \end{array}$$

$$3. \begin{array}{r} 0.16 \\ 90 \overline{)14.4} \end{array}$$

$$4. \begin{array}{r} 0.89 \\ 60 \overline{)53.4} \end{array}$$

$$5. 123.08 \div 34 = \underline{3.62}$$

$$6. 0.57 \div 30 = \underline{0.019}$$

$$7. 562.86 \div 59 = \underline{9.54}$$

$$8. 24.4 \div 80 = \underline{0.305}$$

9. John paid \$7.99 for 3 boxes of cereal. The tax was \$1.69. Excluding tax, how much did John pay for each box of cereal if they all were the same price? \$2.10

10. If a package of granola bars with 12 bars costs \$3.48, how much does each granola bar cost?

A 29¢

B 31¢

C 44¢

D \$1.00

11. **Estimation**  $64.82 \div 11$  is

A a little more than 6.

C a little less than 6.

B a little more than 60.

D a little less than 60.

12. **Explain It** Explain how to divide 0.12 by 8.

**Sample answer: Write zeros in the ones and tenths places in the quotient.**

**Annex a zero in the dividend and continue dividing. The quotient is 0.015.**

# Estimation: Decimals Divided by Whole Numbers

Estimate each quotient. **Sample answers are given.**

1.  $73.5 \div 10$  7      2.  $246.78 \div 83$  3      3.  $185.7 \div 3$  60  
 4.  $535.6 \div 35$  15      5.  $553.9 \div 90$  6      6.  $366.6 \div 12$  30  
 7.  $35.6 \div 7$  5      8.  $86.4 \div 4$  20      9.  $270.53 \div 3$  90  
 10.  $839.7 \div 90$  9      11.  $93.26 \div 3$  30      12.  $77.3 \div 11$  7

13. Joseph is saving \$23 a week to buy a graphing calculator that costs \$275.53. About how many weeks will it take before he can buy the calculator?

about 12 weeks

14. Juan works at a health food store two hours a day, three days a week. His weekly pay is \$73.50. About how much does Juan make per hour?

about \$12 per hour

15. **Reasonableness** Which of the following is a reasonable estimate for the operation  $566.3 \div 63$ ?

A about 16

**B** about 9

C about 4

D about 6

16. **Explain It** When would you estimate a quotient instead of finding the exact quotient?

**Sample answer: Estimating a quotient could help you quickly figure out how many items you can buy with your money or how long a trip will take.**

# Dividing a Decimal by a Decimal

Find each quotient.

1.  $0.8 \overline{)1.84}$  **2.3**

2.  $0.9 \overline{)2.7}$  **3**

3.  $2.5 \overline{)4.75}$  **1.9**

4.  $1.1 \overline{)1.21}$  **1.1**

5.  $7.1 \overline{)6.39}$  **0.9**

6.  $0.8 \overline{)0.648}$  **0.81**

7.  $1.3 \overline{)10.725}$  **8.25**

8.  $0.2 \overline{)0.51}$  **2.55**

9.  $0.07 \overline{)0.77}$  **11**

10.  $4.8 \overline{)4.32}$  **0.9**

11.  $0.7 \overline{)8.4}$  **12**

12.  $2.3 \overline{)6.9}$  **3**

13. Chan paid \$4.75 for trail mix that costs \$2.50 a pound. How many pounds of trail mix did he buy?

**1.9 pounds**

14. Max's family car has a gas tank that holds 12.5 gallons of gas. It cost \$40.62 to completely fill the tank yesterday. What was the price of gas per gallon?

**\$3.25**

15. **Strategy Practice** Strawberries cost \$5.99 per pound, and bananas cost \$0.59 per pound. How many pounds of bananas could you buy for the cost of one pound of strawberries?

A 101.5 pounds **B** 10.15 pounds C 5.99 pounds D .59 pounds

16. **Explain It** When dividing a decimal by a decimal, why is it sometimes necessary to add a zero to the right of the decimal point in the quotient?

**Sample answer: Often, after moving decimal points to make the numbers ready for division, you must add a zero so that a smaller number can be divided by a larger number.**

## Problem Solving: Multiple-Step Problems

Write and answer the hidden question or questions in each problem and then solve the problem.

Write your answer in a complete sentence.

Storewide Sale	
Jeans	\$29.95 for 1 pair OR 2 pairs for \$55.00
T-shirts	\$9.95 for 1 OR 3 T-shirts for \$25.00

- Sue bought 2 pairs of jeans and a belt that cost \$6.95. The tax on the items was \$5.85. Sue paid the cashier \$70.00. How much money did Sue receive in change?

**What was the total cost of Sue's items?  
\$67.80; Sue received \$2.20 in change.**

- A recreation department purchased 12 T-shirts for day camp. The department does not have to pay sales tax. It paid with a \$100.00 bill. How much change did it receive?

**What was the cost for 12 T-shirts?  
\$100.00; The department received no change, because it paid the exact amount.**

- When Mrs. Johnson saw the sale, she decided to get clothes for each child in her family. She bought each of her 6 children a pair of jeans and a T-shirt. She paid \$14.35 in sales tax. How much was Mrs. Johnson's total bill?

**A** \$94.35      **B** \$119.70      **C** \$229.35      **D** \$253.35

- Write a Problem** Write a two-step problem that contains a hidden question about buying something at the mall. Tell what the hidden question is and solve your problem. Use \$8.95 somewhere in your equation. Write your answer in a complete sentence.

**Check students' problems.**

- Explain It** What are hidden questions and why are they important when solving multiple-step problems?

**Sample answer: Hidden questions are not directly stated in the problem. The answers to the hidden questions give information needed to solve the problem.**

# Basic Geometric Ideas

Use the diagram at the right. Name the following.

**Sample answers given for 1–7.**

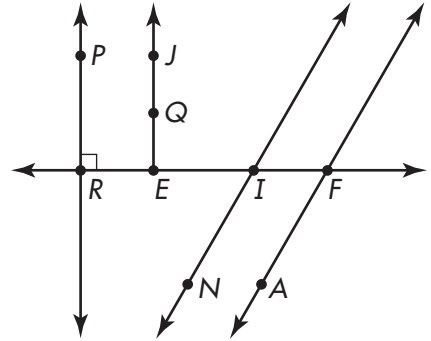

1. three points  
**points P, R, and A**

2. a ray  
 **$\overrightarrow{EJ}$**

3. two intersecting lines but not perpendicular  
 **$\overleftrightarrow{RF}$  intersects  $\overleftrightarrow{NI}$**

4. two parallel lines

**$\overleftrightarrow{NI} \parallel \overleftrightarrow{AF}$**

5. a line segment

**$\overline{JE}$**

6. two perpendicular lines

**$\overleftrightarrow{PR} \perp \overleftrightarrow{RF}$**

7. **Explain It** Can a line segment have two midpoints? Explain.

**No, a midpoint is a point halfway between the endpoints of a line segment. There cannot be two midpoints.**

8. Which type of lines are shown by the figure?

- A** Congruent      **C** Perpendicular  
**B** Parallel      **D** Curved

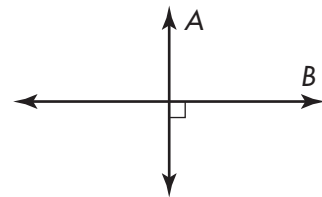

9. **Draw a picture** Draw and label two perpendicular line segments  $\overline{KL}$  and  $\overline{MN}$ .



# Measuring and Classifying Angles

Classify each angle as *acute*, *right*, *obtuse*, or *straight*. Then measure each angle. (Hint: Draw longer sides if necessary.)

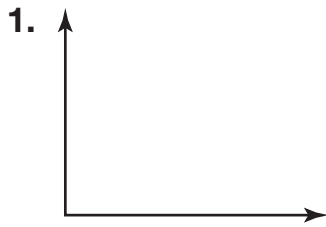

**Right angle;  $90^\circ$**

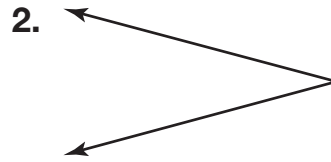

**Acute angle;  $30^\circ$**

Draw an angle with each measure.

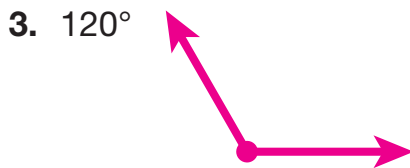

5. Draw an acute angle. Label it with the letters *A*, *B*, and *C*. What is the measure of the angle?

**Check students' drawings and measures.**

6. Which kind of angle is shown in the figure below?

**A** Acute

**C** Obtuse

**B** Right

**D** Straight



7. **Explain It** Explain how to use a protractor to measure an angle.

**Place center of protractor on angle's vertex so the  $0^\circ$  mark is on one side of angle. Read measure where other side of angle crosses protractor.**

# Polygons

Name each polygon. Then tell if it appears to be a regular polygon.

1.

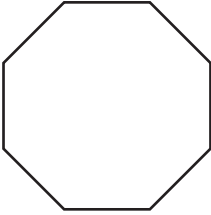

**Octagon;**  
**regular**

2.

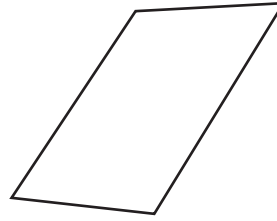

**Quadrilateral;**  
**not regular**

3. Name the polygon. Name the vertices.

**Quadrilateral;**

**B, E, H, T**

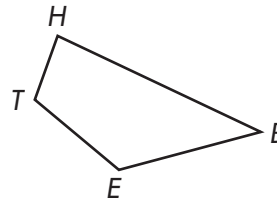

4. Which polygon has eight sides?

A quadrilateral

B pentagon

C hexagon

 D octagon

5. **Explain It** Draw two regular polygons and two that are irregular. Use geometric terms to describe one characteristic of each type.

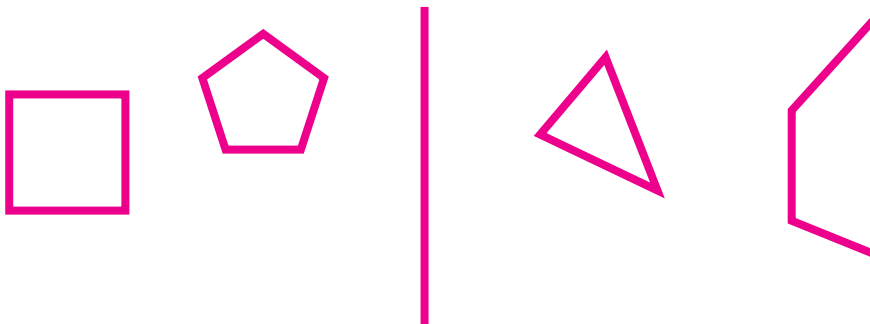

**Sample answer: The regular polygons**  
**have congruent sides. The irregular**  
**polygons have different angle measures.**



# Triangles

Classify each triangle by its sides and then by its angles.

1.

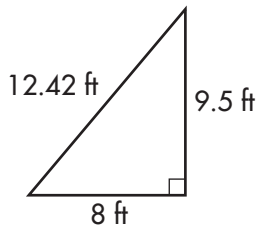

**Scalene triangle;  
right triangle**

2.

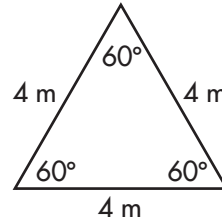

**Equilateral triangle;  
acute triangle**

The measures of two angles of a triangle are given. Find the measure of the third angle.

3.  $47^\circ, 62^\circ, \underline{71^\circ}$

4.  $29^\circ, 90^\circ, \underline{61^\circ}$

5.  $75^\circ, 75^\circ, \underline{30^\circ}$

6.  $54^\circ, 36^\circ, \underline{90^\circ}$

7. Judy bought a new tent for a camping trip. Look at the side of the tent with the opening to classify the triangle by its sides and its angles.

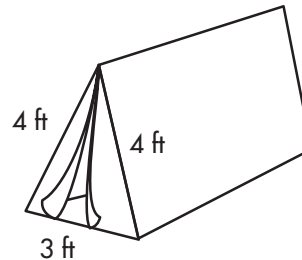

**Isosceles triangle; acute triangle**

8. **Reasonableness** Which describes a scalene triangle?

**A** 4 equal sides   **B** 3 equal sides   **C** 2 equal sides   **D** 0 equal sides

9. **Explain It** The lengths of two sides of a triangle are 15 in. each.

The third side measures 10 in. What type of triangle is this?

Explain your answer using geometric terms.

**It is an isosceles triangle, because two sides are the same length.**

# Quadrilaterals

Classify each quadrilateral. Be as specific as possible.

1.

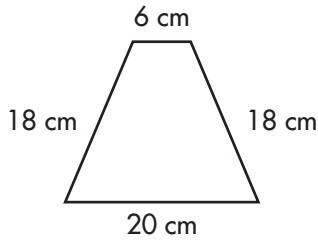

**Trapezoid**

2.

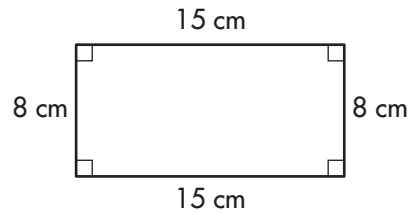

**Rectangle**

3.

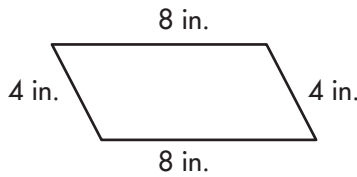

**Parallelogram**

4.

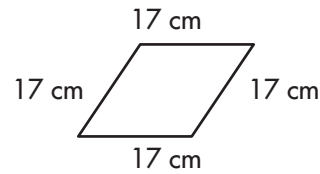

**Rhombus**

For **5** and **6**, the measures of three angles of a quadrilateral are given. Find the measure of the fourth angle.

5.  $90^\circ$ ,  $145^\circ$ ,  $78^\circ$ ,  **$47^\circ$**

6.  $110^\circ$ ,  $54^\circ$ ,  $100^\circ$ ,  **$96^\circ$**

7. Name the vertices of the square to the right.

**F, G, A, L**

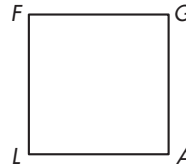

8. Three of the angles of a quadrilateral measure  $80^\circ$ ,  $100^\circ$ , and  $55^\circ$ . Which is the measure of the fourth angle?

A  $115^\circ$ B  $120^\circ$ **C**  $125^\circ$ D  $130^\circ$ 

9. **Explain It** Can a trapezoid have four obtuse angles? Explain.

**Sample answer: The figure would not be able to close the fourth side if all of the angles were obtuse.**

# Problem Solving: Make and Test Generalizations

In 1 through 6, test the generalization and state whether it appears to be correct or incorrect. If incorrect, give an example to support why.

1. All triangles have right angles.

**Incorrect; some triangles have one right angle and some triangles don't have any.**

2. All rectangles have right angles.

**Correct.**

3. Any two triangles can be joined to make a rhombus.

**Incorrect; only two congruent isosceles triangles can be joined to make a rhombus.**

4. All rectangles can be cut in half vertically or horizontally to make two congruent rectangles.

**Correct.**

5. Intersecting lines are also parallel.

**Incorrect; parallel lines will never intersect.**

6. How many whole numbers have exactly three digits? Hint: 999 is the greatest whole number with three digits.

A 890

**B** 900

C 990

D 999

7. **Explain It** How can you show that a generalization is correct?

**Sample answer: test it twice to show that it is correct both times.**

# Meanings of Fractions

Write the fraction that names the shaded part.

1.   $\frac{1}{6}$  \_\_\_\_\_

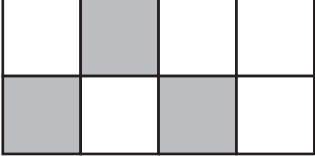
2.   $\frac{3}{8}$  \_\_\_\_\_

**Sample answers given for 3 and 4.**

In 3 and 4, draw a model to show each fraction.

3.  $\frac{4}{8}$  as part of a set

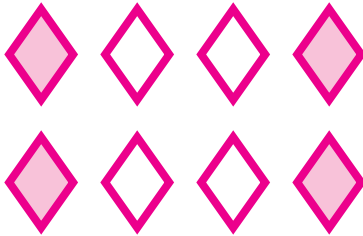

4.  $\frac{5}{10}$  as part of a region

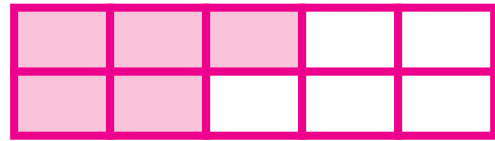

5. **Number Sense** If  $\frac{5}{17}$  of a region is shaded, what part is not shaded?

$\frac{12}{17}$  \_\_\_\_\_

6. Camp Big Trees has 3 red canoes and 4 blue canoes. What fraction of the canoes are red?

$\frac{3}{7}$  \_\_\_\_\_

7. In a class of 24 students, 13 students are girls. What fraction of the students are boys?

A  $\frac{11}{13}$

**B**  $\frac{11}{24}$

C  $\frac{13}{24}$

D  $\frac{24}{11}$

8. **Explain It** Trisha says that if  $\frac{5}{7}$  of her pencils are yellow, then  $\frac{2}{7}$  are not yellow. Is she correct? Explain.

**Sample answer: Yes, Trisha is correct because if 5 out of 7 are yellow, 2 out of 7 must not be yellow.**

# Fractions and Division

Give each answer as a fraction. Then graph the answer on the number line.

1.  $3 \div 7$   $\frac{3}{7}$  

2.  $4 \div 9$   $\frac{4}{9}$  

3.  $1 \div 5$   $\frac{1}{5}$  

4. Use the number line to name the fraction at point A.  $\frac{6}{16}$

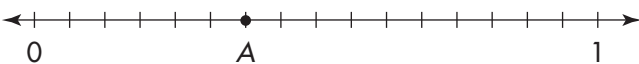

At a golf course, there are 18 holes. Of the 18 holes, 3 are par threes, 8 are par fours, and 7 are par fives. What fraction of the holes are

5. par fives?  $\frac{7}{18}$       6. par threes?  $\frac{3}{18}$       7. par fours?  $\frac{8}{18}$

8. **Number Sense** Explain how you know that  $7 \div 9$  is less than 1.

**Sample answer: Because 7 is less than 9, 7 cannot be divided by 9 one time.**

9. After school, Chase spends 20 min reading, 30 min practicing the piano, 15 min cleaning his room, and 40 min doing his homework. Chase is busy for 105 min. What fraction of the time does he spend cleaning his room?  $\frac{15}{105}$

10. Venietta read 4 books in 7 weeks. How many books did she read each week?

A  $\frac{6}{7}$

**B**  $\frac{4}{7}$

C  $\frac{3}{7}$

D  $\frac{2}{7}$

11. **Explain It** In 5 min, Peter completed 2 math problems. Yvonne says he did  $\frac{3}{5}$  of a problem each minute. Is she correct? Explain.

**Sample answer: No, Peter completed  $\frac{2}{5}$  of a problem each minute.**

# Mixed Numbers and Improper Fractions

Write an improper fraction and a mixed number for each model.

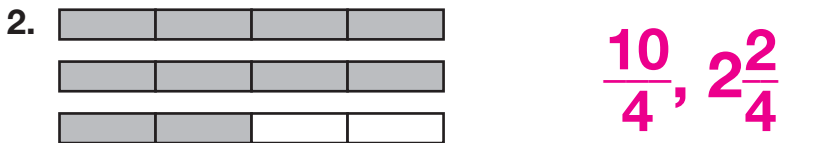
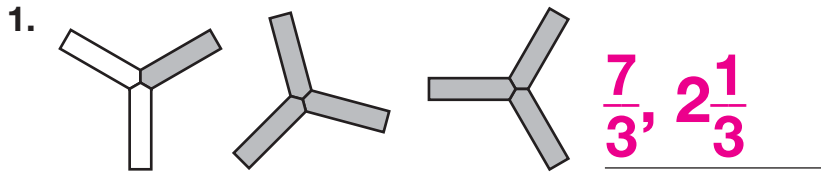

Write each improper fraction as a mixed number.

3.  $\frac{12}{7}$   $1\frac{5}{7}$

4.  $\frac{7}{3}$   $2\frac{1}{3}$

5.  $\frac{5}{2}$   $2\frac{1}{2}$

6.  $\frac{9}{4}$   $2\frac{1}{4}$

7.  $\frac{29}{13}$   $2\frac{3}{13}$

8.  $\frac{34}{8}$   $4\frac{2}{8}$

Write each mixed number as an improper fraction.

9.  $2\frac{4}{5}$   $\frac{14}{5}$

10.  $8\frac{7}{9}$   $\frac{79}{9}$

11.  $3\frac{6}{7}$   $\frac{27}{7}$

12.  $7\frac{1}{8}$   $\frac{57}{8}$

13.  $4\frac{3}{7}$   $\frac{31}{7}$

14.  $5\frac{1}{4}$   $\frac{21}{4}$

15. **Number Sense** Jasmine has 41 lb of dog food to pour into 5 dishes. How many pounds of dog food should she pour in each dish?

A  $4\frac{1}{5}$  lb

**B**  $8\frac{1}{5}$  lb

C 10 lb

D  $11\frac{1}{8}$  lb

16. **Explain It** Hank needs 3 quarters to play one video game each time. If he has 14 quarters, how many times can he play? Explain.

**Sample answer:** Hank can play the video game 4 times. He cannot play the game  $4\frac{2}{3}$  times because the game will not work with only 2 quarters.

# Equivalent Fractions

Name two equivalent fractions for each fraction.

**Sample answers given for 1–6.**

1.  $\frac{5}{15}$   $\frac{1}{3}$ ,  $\frac{10}{30}$

2.  $\frac{6}{36}$   $\frac{1}{6}$ ,  $\frac{3}{18}$

3.  $\frac{2}{12}$   $\frac{1}{6}$ ,  $\frac{4}{24}$

4.  $\frac{4}{28}$   $\frac{2}{14}$ ,  $\frac{1}{7}$

5.  $\frac{3}{21}$   $\frac{6}{42}$ ,  $\frac{1}{7}$

6.  $\frac{2}{11}$   $\frac{4}{22}$ ,  $\frac{6}{33}$

Find the missing number to make the fractions equivalent.

7.  $\frac{4}{13} = \frac{8}{x}$   $x = 26$

8.  $\frac{12}{30} = \frac{n}{90}$   $n = 36$

9.  $\frac{q}{54} = \frac{2}{9}$   $q = 12$

10.  $\frac{14}{h} = \frac{7}{20}$   $h = 40$

11. Renie gave each of six people  $\frac{1}{10}$  of a veggie pizza. Renie has  $\frac{2}{5}$  of the pizza left. Explain how this is true.

**Sample answer: Renie gave away  $\frac{6}{10}$ , or  $\frac{3}{5}$ , of the pizza, so  $\frac{2}{5}$ , or  $\frac{4}{10}$ , of it is left.**

12. Which fraction is equivalent to  $\frac{3}{7}$ ?

A  $\frac{3}{6}$

**B**  $\frac{6}{14}$

C  $\frac{3}{17}$

D  $\frac{7}{7}$

13. **Explain It** Jacqueline had four \$5 bills. She bought a shirt for \$10. Explain what fraction of her money Jacqueline has left. Use equivalent fractions.

**Sample answer: Four \$5 bills equal \$20. After she spent \$10, she had  $\frac{10}{20}$ , or  $\frac{1}{2}$ , of her money.**

# Comparing and Ordering Fractions and Mixed Numbers

Compare the numbers. Write  $>$ ,  $<$ , or  $=$  for each  $\bigcirc$ .

1.  $\frac{6}{7} \bigcirc \frac{6}{8}$

2.  $\frac{4}{9} \bigcirc \frac{2}{3}$

3.  $1\frac{1}{10} \bigcirc 1\frac{1}{12}$

4.  $2\frac{4}{5} \bigcirc 2\frac{5}{6}$

5.  $3\frac{6}{9} \bigcirc 3\frac{2}{3}$

6.  $\frac{2}{5} \bigcirc \frac{2}{8}$

Order the numbers from least to greatest.  $\frac{4}{8}, \frac{5}{8}, \frac{4}{6}, \frac{3}{4}$

7.  $\frac{4}{6}, \frac{4}{8}, \frac{3}{4}, \frac{5}{8}$

8.  $4\frac{1}{4}, 4\frac{1}{8}, 5\frac{10}{11}, 4\frac{2}{12}$

9.  $1\frac{3}{7}, 1\frac{3}{4}, 1\frac{2}{4}, 1\frac{8}{14}$

$1\frac{3}{7}, 1\frac{2}{4}, 1\frac{3}{4}, 1\frac{8}{14}$

$4\frac{1}{8}, 4\frac{2}{12}, 4\frac{1}{4}, 5\frac{10}{11}$

10. **Number Sense** How do you know that  $5\frac{1}{4}$  is less than  $5\frac{4}{10}$ ?

$5\frac{1}{4} = 5\frac{5}{20}; 5\frac{4}{10} = 5\frac{8}{20}; 5\frac{5}{20} < 5\frac{8}{20}$

11. A mechanic uses four wrenches to fix Mrs. Aaron's car. The wrenches are different sizes:  $\frac{5}{16}$  in.,  $\frac{1}{2}$  in.,  $\frac{1}{4}$  in., and  $\frac{7}{16}$  in. Order the sizes of the wrenches from greatest to least.

$\frac{1}{2}$  in.,  $\frac{7}{16}$  in.,  $\frac{5}{16}$  in.,  $\frac{1}{4}$  in.

12. Which is greater than  $6\frac{1}{3}$ ?

A  $6\frac{1}{6}$

B  $6\frac{1}{5}$

C  $6\frac{1}{4}$

D  $6\frac{1}{2}$

13. **Explain It** Compare  $3\frac{3}{22}$  and  $3\frac{2}{33}$ . Which is greater? How do you know?

$3\frac{3}{22} = 3\frac{9}{66}$ , which is greater than

$3\frac{2}{33} = 3\frac{4}{66}$



# Common Factors and Greatest Common Factor

Find the GCF of each pair of numbers.

- |           |          |           |          |            |           |
|-----------|----------|-----------|----------|------------|-----------|
| 1. 15, 50 | <u>5</u> | 2. 6, 27  | <u>3</u> | 3. 10, 25  | <u>5</u>  |
| 4. 18, 32 | <u>2</u> | 5. 7, 28  | <u>7</u> | 6. 54, 108 | <u>54</u> |
| 7. 25, 55 | <u>5</u> | 8. 14, 48 | <u>2</u> | 9. 81, 135 | <u>27</u> |

10. **Number Sense** Can the GCF of 16 and 42 be less than 16? Explain.

**Yes; Sample answer: The greatest common factor will be less than 16, because 42 is not evenly divisible by 16.**

11. A restaurant received a shipment of 42 gal of orange juice and 18 gal of cranberry juice. The juice needs to be poured into equal-sized containers. What is the largest amount of juice that each container can hold of each kind of juice?

**6 gal**

12. At a day camp, there are 56 girls and 42 boys. The campers need to be split into equal groups. Each has either all girls or all boys. What is the greatest number of campers each group can have?

**14 campers**

13. Which is the GCF of 24 and 64?

A 4

**B 8**

C 14

D 12

14. **Explain It** Do all even numbers have 2 as a factor? Explain.

**Sample answer: Yes, because all even numbers are divisible by 2**

# Fractions in Simplest Form

Write each fraction in simplest form.

1.  $\frac{5}{10}$  ———  $\frac{1}{2}$

2.  $\frac{6}{24}$  ———  $\frac{1}{4}$

3.  $\frac{9}{27}$  ———  $\frac{1}{3}$

4.  $\frac{3}{15}$  ———  $\frac{1}{5}$

5.  $\frac{10}{12}$  ———  $\frac{5}{6}$

6.  $\frac{9}{15}$  ———  $\frac{3}{5}$

7.  $\frac{2}{18}$  ———  $\frac{1}{9}$

8.  $\frac{25}{60}$  ———  $\frac{5}{12}$

9.  $\frac{12}{72}$  ———  $\frac{1}{6}$

10. **Number Sense** Explain how you can tell  $\frac{4}{5}$  is in simplest form.

**Sample answer: The numerator and the denominator have no common factors other than 1.**

Write in simplest form.

11. What fraction of the problems on the math test will be word problems?

$$\frac{1}{7}$$

### Math Test

- ➔ 20 Multiple-choice problems
- ➔ 10 Fill in the blanks
- ➔ 5 Word problems

12. What fraction of the problems on the math test will be multiple-choice problems?

$$\frac{4}{7}$$

13. Which is the simplest form of  $\frac{10}{82}$ ?

A  $\frac{1}{8}$

B  $\frac{1}{22}$

C  $\frac{10}{82}$

D  $\frac{5}{41}$

14. **Explain It** Explain how you can find the simplest form of  $\frac{100}{1,000}$ .

**Sample answer: The GCF of 100 and 1,000 is 100. The simplest form is  $\frac{100 \div 100}{1,000 \div 100} = \frac{1}{10}$ .**

# Tenths and Hundredths

Write a decimal and fraction for the shaded portion of each model.

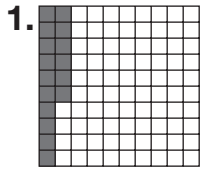

0.16;

$\frac{4}{25}$

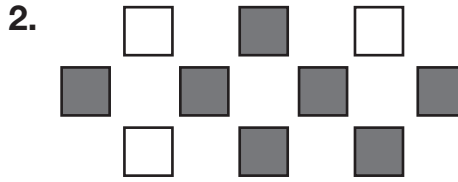

0.7;

$\frac{7}{10}$

Write each decimal as either a fraction or a mixed number.

3. 0.6  $\frac{6}{10}$

4. 0.73  $\frac{73}{100}$

5. 6.9  $6\frac{9}{10}$

6. 8.57  $8\frac{57}{100}$

Write each fraction or mixed number as a decimal.

7.  $\frac{7}{10}$  0.7

8.  $\frac{33}{100}$  0.33

9.  $7\frac{2}{10}$  7.2

10.  $3\frac{9}{100}$  3.09

Use division to change each fraction to a decimal.

11.  $\frac{4}{5}$  0.8

12.  $\frac{12}{25}$  0.48

13.  $\frac{1}{50}$  0.02

14.  $\frac{11}{20}$  0.55

15. **Strategy Practice** When you convert 0.63 to a fraction, which of the following could be the first step of the process?

- A Since there are 63 hundredths, multiply 0.63 and 100.
- B Since there are 63 tenths, divide 0.63 by 10.
- C Since there are 63 tenths, place 63 over 10.
- D** Since there are 63 hundredths, place 63 over 100.

# Thousandths

Write each decimal as either a fraction or a mixed number.

$$1. \quad 0.007 \quad \frac{7}{1,000}$$

$$2. \quad 0.052 \quad \frac{52}{1,000}$$

$$3. \quad 0.038 \quad \frac{38}{1,000}$$

$$4. \quad 0.259 \quad \frac{259}{1,000}$$

$$5. \quad 3.020 \quad 3\frac{20}{1,000}$$

$$6. \quad 4.926 \quad 4\frac{926}{1,000}$$

Write each fraction as a decimal.

$$7. \quad \frac{73}{1,000} \quad 0.073$$

$$8. \quad \frac{593}{1,000} \quad 0.593$$

$$9. \quad \frac{854}{1,000} \quad 0.854$$

$$10. \quad \frac{11}{1,000} \quad 0.011$$

$$11. \quad \frac{5}{1,000} \quad 0.005$$

$$12. \quad \frac{996}{1,000} \quad 0.996$$

Write the numbers in order from least to greatest.

$$13. \quad \frac{5}{1,000}, 0.003, \frac{9}{1,000} \quad 0.003, \frac{5}{1,000}, \frac{9}{1,000}$$

$$14. \quad 0.021, 0.845, \frac{99}{1,000} \quad 0.021, \frac{99}{1,000}, 0.845$$

15. Look at the model at the right. Write a fraction and a decimal that the model represents.

$$\frac{11}{1,000} \text{ and } 0.011$$

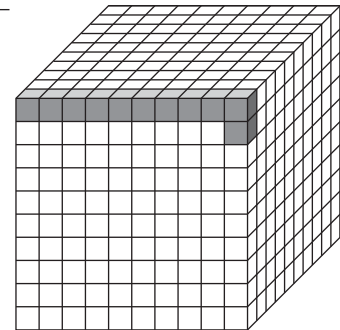

16. **Reasoning** In Tasha's school, 0.600 of the students participate in a school sport. If there are one thousand students in Tasha's school, how many participate in a school sport?

A 6,000

**B** 600

C 60

D 6

17. **Explain It** Explain how knowing that  $5 \div 8 = 0.625$  helps you write the decimal for  $4\frac{5}{8}$ .

**Sample answer: Knowing that  $5 \div 8 = 0.625$  gives the digits to write to the right of the decimal point.**

# Fractions and Decimals on the Number Line

Draw a number line to show the set of numbers. Then order the numbers from least to greatest.

1.  $0.75, \frac{8}{10}, 0.2, \frac{2}{5}$       $0.2, \frac{2}{5}, 0.75, \frac{8}{10}$

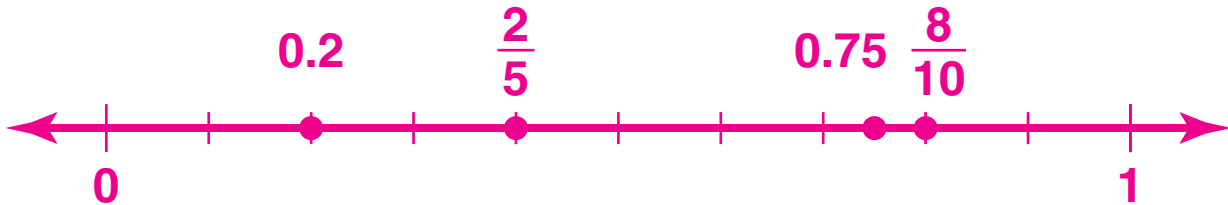

Write a fraction or mixed number in simplest form and a decimal that name each point.

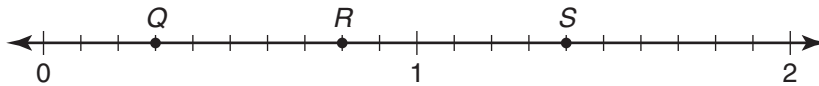

2. Point Q  $\frac{3}{10}; 0.3$      3. Point R  $\frac{4}{5}; 0.8$      4. Point S  $1\frac{2}{5}; 1.4$

5. Uma recorded the distances that volunteers walked in the charity event. Grace walked  $1\frac{3}{5}$  mi, Wendell walked 1.3 mi, and Simon walked  $1\frac{1}{10}$  mi. Show these distances on a number line. Who walked the farthest?

**Sample drawing:**



Grace

6. **Number Sense** Which is a decimal that could go between the mixed numbers  $4\frac{3}{5}$  and  $4\frac{9}{10}$  on a number line?

- A 4.45     B 4.5     **C 4.75**     D 4.92

7. **Explain It** Explain how you know that 5.5 is to the right of  $5\frac{1}{4}$  on the number line.

Sample answer:  $5\frac{1}{4} = 5.25; 5.25 < 5.5;$

So, 5.5 must be to the right of  $5\frac{1}{4}$ .

## Problem Solving: Writing to Explain

Estimate the fractional part of the shaded portions below.  
Explain how you decided.

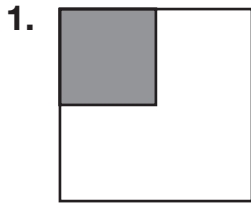

The shaded area is about half  
of  $\frac{1}{2}$ , so it is about  $\frac{1}{4}$ .



About  $\frac{2}{3}$ , because it is more  
than  $\frac{1}{2}$ , but less than  $\frac{3}{4}$

3. Draw a square and shade about  $\frac{1}{8}$  of it. How did you decide how much to shade?

**Check students' work. Sample:**  
I shaded half of  $\frac{1}{4}$ .

4. Draw two rectangles that are different sizes. Shade about  $\frac{1}{2}$  of each. Are the shaded parts the same amount? Explain.

**Check students' drawings. No; the shaded parts are not the same amount, because the rectangles are not the same size.**

5. **Explain It** Look at a picture of the American flag. Approximately what part of the flag is blue? Explain.

About  $\frac{3}{16}$ ; since less than  $\frac{1}{4}$  of the flag is blue, and white stars are also in the blue area.

# Adding and Subtracting Fractions with Like Denominators

Add or subtract. Simplify if possible.

$$1. \quad \begin{array}{r} \frac{10}{12} \\ + \frac{8}{12} \\ \hline \end{array}$$

$$1\frac{1}{2}$$

$$2. \quad \begin{array}{r} \frac{8}{9} \\ - \frac{5}{9} \\ \hline \end{array}$$

$$\frac{1}{3}$$

$$3. \quad \begin{array}{r} \frac{7}{10} \\ + \frac{2}{10} \\ \hline \end{array}$$

$$\frac{9}{10}$$

$$4. \quad \begin{array}{r} \frac{2}{3} \\ - \frac{1}{3} \\ \hline \end{array}$$

$$\frac{1}{3}$$

$$5. \quad \frac{6}{8} + \frac{5}{8} + \frac{3}{8} = 1\frac{3}{4}$$

$$6. \quad \frac{8}{10} - \frac{3}{10} = \frac{1}{2}$$

$$7. \quad \frac{1}{4} + \frac{2}{4} + \frac{3}{4} = 1\frac{1}{2}$$

$$8. \quad \frac{9}{11} - \frac{1}{11} = \frac{8}{11}$$

$$9. \quad \frac{2}{5} + \frac{2}{5} + \frac{3}{5} = 1\frac{2}{5}$$

$$10. \quad \frac{7}{8} - \frac{3}{8} = \frac{1}{2}$$

11. What fraction could you add to  $\frac{4}{7}$  to get a sum greater than 1?

any fraction greater than  $\frac{3}{7}$

12. **Reasoning** Write three fractions, using 10 as the denominator, whose sum is 1.

Possible answer:  $\frac{1}{10} + \frac{3}{10} + \frac{6}{10} = 1$

13. Which of the following represents the difference between two equal fractions?

A 1

B  $\frac{1}{2}$

C  $\frac{1}{4}$

**D** 0

14. **Explain It** In one night, George reads 3 chapters of a book with 27 chapters. After the second night, he has read a total of  $\frac{8}{27}$  of the book. Explain how you would determine the number of chapters George read the second night. Solve the problem.

$\frac{8}{27} - \frac{3}{27} = \frac{5}{27}$ ; on the second night, George  $\frac{5}{27} \times 27 = 5$  chapters

# Common Multiples and Least Common Multiple

Find the LCM of each pair of numbers.

- |              |           |              |           |
|--------------|-----------|--------------|-----------|
| 1. 3 and 6   | <u>6</u>  | 2. 7 and 10  | <u>70</u> |
| 3. 8 and 12  | <u>24</u> | 4. 2 and 5   | <u>10</u> |
| 5. 4 and 6   | <u>12</u> | 6. 3 and 4   | <u>12</u> |
| 7. 5 and 8   | <u>40</u> | 8. 2 and 9   | <u>18</u> |
| 9. 6 and 7   | <u>42</u> | 10. 4 and 7  | <u>28</u> |
| 11. 5 and 20 | <u>20</u> | 12. 6 and 12 | <u>12</u> |

13. Rosario is buying pens for school. Blue pens are sold in packages of 6. Black pens are sold in packages of 3, and green pens are sold in packages of 2. What is the least number of pens she can buy to have equal numbers of pens in each color?

**6 of each**

14. Jason's birthday party punch calls for equal amounts of pineapple juice and orange juice. Pineapple juice comes in 6-oz cans and orange juice comes in 10-oz cans. What is the least amount he can mix of each kind of juice without having any left over?

**30 oz of each**

15. Reasonableness Dawn ordered 4 pizzas each costing between 8 and 12 dollars. What is a reasonable total cost of all 4 pizzas?

- A less than \$24                      **C** between \$32 and \$48  
B between \$12 and \$24            D about \$70

16. Explain It Why is 35 the LCM of 7 and 5?

**Sample answer: It is the smallest number divisible by both 7 and 5.**



# Adding Fractions with Unlike Denominators

Find each sum. Simplify if necessary.

$$1. \frac{2}{9} + \frac{1}{3} = \frac{\overset{5}{\cancel{9}}}{\cancel{11}}$$

$$2. \frac{1}{7} + \frac{3}{21} = \frac{\overset{2}{\cancel{7}}}{\cancel{3}}$$

$$3. \frac{2}{3} + \frac{1}{5} = \frac{\overset{13}{\cancel{15}}}{\cancel{15}}$$

$$4. \frac{1}{4} + \frac{2}{3} = \frac{\overset{11}{\cancel{12}}}{\cancel{12}}$$

$$5. \frac{1}{12} + \frac{4}{6} = \frac{\overset{3}{\cancel{4}}}{\cancel{4}}$$

$$6. \frac{1}{2} + \frac{3}{5} = \overset{1}{1} \frac{\overset{1}{\cancel{10}}}{\cancel{10}}$$

$$7. \frac{1}{6} + \frac{5}{12} = \frac{\overset{7}{\cancel{12}}}{\cancel{12}}$$

$$8. \frac{4}{6} + \frac{1}{3} = \overset{1}{1}$$

$$9. \frac{2}{5} + \frac{1}{8} = \frac{\overset{21}{\cancel{40}}}{\cancel{40}}$$

$$10. \frac{3}{4} + \frac{4}{5} = \overset{1}{1} \frac{\overset{11}{\cancel{20}}}{\cancel{20}}$$

$$11. \frac{11}{12} + \frac{1}{3} = \overset{1}{1} \frac{\overset{1}{\cancel{4}}}{\cancel{4}}$$

$$12. \frac{4}{8} + \frac{1}{2} = \overset{1}{1}$$

Jeremy collected nickels for one week. He is making stacks of his nickels to determine how many he has. The thickness of one nickel is  $\frac{1}{16}$  in.

13. How tall is a stack of 16 nickels?

**1 in.**

14. What is the combined height of 3 nickels, 2 nickels, and 1 nickel?

**$\frac{3}{8}$  in.**

15. **Number Sense** Which fraction is greatest?

**A**  $\frac{5}{6}$

**B**  $\frac{7}{9}$

**C**  $\frac{2}{3}$

**D**  $\frac{9}{12}$

16. **Explain It** Which equivalent fraction would you have to use in order to add  $\frac{3}{5}$  to  $\frac{21}{25}$ ?

**$\frac{15}{25} + \frac{21}{25}$**

# Subtracting Fractions with Unlike Denominators

Find the difference. Simplify if necessary.

- |   |  |  |
|---|--|--|
| 1. $\frac{10}{12} - \frac{1}{4} = \frac{\frac{7}{12}}{1}$ | 2. $\frac{9}{10} - \frac{3}{5} = \frac{\frac{3}{10}}{7}$ | 3. $\frac{7}{8} - \frac{2}{6} = \frac{\frac{13}{24}}{1}$   |
| 4. $\frac{7}{12} - \frac{1}{4} = \frac{\frac{3}{12}}{1}$  | 5. $\frac{4}{5} - \frac{1}{3} = \frac{\frac{1}{15}}{1}$  | 6. $\frac{2}{3} - \frac{1}{6} = \frac{\frac{1}{2}}{1}$     |
| 7. $\frac{4}{8} - \frac{1}{4} = \frac{\frac{1}{4}}{1}$    | 8. $\frac{4}{10} - \frac{1}{5} = \frac{\frac{1}{5}}{1}$  | 9. $\frac{7}{9} - \frac{2}{3} = \frac{\frac{1}{9}}{1}$     |
| 10. $\frac{9}{15} - \frac{1}{3} = \frac{\frac{4}{15}}{1}$ | 11. $\frac{4}{12} - \frac{1}{6} = \frac{\frac{1}{6}}{1}$ | 12. $\frac{14}{20} - \frac{3}{5} = \frac{\frac{1}{10}}{1}$ |

13. The pet shop owner told Jean to fill her new fish tank  $\frac{3}{4}$  full with water. Jean filled it  $\frac{9}{12}$  full. What fraction of the tank does Jean still need to fill?

**0**

14. Paul's dad made a turkey pot pie for dinner on Wednesday. The family ate  $\frac{4}{8}$  of the pie. On Thursday after school, Paul ate  $\frac{2}{16}$  of the pie for a snack. What fraction of the pie remained?

**$\frac{3}{8}$**

15. **Algebra** Gracie read 150 pages of a book she got for her birthday. The book is 227 pages long. Which equation shows how to find the amount she still needs to read to finish the story?

A  $150 - n = 227$                       C  $n - 150 = 227$

B  $227 + 150 = n$                       **D**  $n + 150 = 227$

16. **Explain It** Why do fractions need to have a common denominator before you add or subtract them?

**The denominator tells you what size parts you are adding or subtracting. The parts must be the same size when you add or subtract.**

# Adding Mixed Numbers

Estimate the sum first. Then add. Simplify if necessary.

$$1. \quad 7\frac{2}{3} + 8\frac{5}{6} \quad \underline{16\frac{1}{2}} \qquad 2. \quad 4\frac{3}{4} + 2\frac{2}{5} \quad \underline{7\frac{3}{20}}$$

$$3. \quad 11\frac{9}{10} + 3\frac{1}{20} \quad \underline{14\frac{19}{20}} \qquad 4. \quad 7\frac{6}{7} + 5\frac{2}{7} \quad \underline{13\frac{1}{7}}$$

$$5. \quad 5\frac{8}{9} + 3\frac{1}{2} \quad \underline{9\frac{7}{18}} \qquad 6. \quad 21\frac{11}{12} + 17\frac{2}{3} \quad \underline{39\frac{7}{12}}$$

7. **Number Sense** Write two mixed numbers with a sum of 3.

**Sample answer:**  $1\frac{1}{4} + 1\frac{3}{4} = 3$

8. What is the total measure of an average man's brain and heart in kilograms?

$\underline{1\frac{7}{10} \text{ kg}}$

### Vital Organ Measures

Average woman's brain	$1\frac{3}{10}$ kg	$2\frac{4}{5}$ lb
Average man's brain	$1\frac{2}{5}$ kg	3 lb
Average human heart	$\frac{3}{10}$ kg	$\frac{7}{10}$ lb

9. What is the total weight of an average woman's brain and heart in pounds?  $\underline{3\frac{1}{2} \text{ lb}}$
10. What is the sum of the measures of an average man's brain and an average woman's brain in kilograms?  $\underline{2\frac{7}{10} \text{ kg}}$
11. Which is a good comparison of the estimated sum and the actual sum of  $7\frac{7}{8} + 2\frac{11}{12}$ ?
- A Estimated < actual                      C Actual > estimated
- B Actual = estimated                      **D Estimated > actual**
12. **Explain It** Can the sum of two mixed numbers be equal to 2? Explain why or why not.

**No; Sample answer: It is impossible for two mixed numbers to equal 2 because every mixed number is greater than 1.**

# Subtracting Mixed Numbers

Estimate the difference first. Then subtract. Simplify if necessary.

1. 
$$\begin{array}{r} 10\frac{3}{4} \\ - 7\frac{1}{4} \\ \hline \end{array}$$

$$3\frac{1}{2}$$

2. 
$$\begin{array}{r} 7\frac{3}{7} \\ - 2\frac{8}{21} \\ \hline \end{array}$$

$$5\frac{1}{21}$$

3. 
$$\begin{array}{r} 3 \\ - 2\frac{2}{3} \\ \hline \end{array}$$

$$\frac{1}{3}$$

4. 
$$\begin{array}{r} 17\frac{7}{8} \\ - 12\frac{3}{12} \\ \hline \end{array}$$

$$5\frac{5}{8}$$

5. 
$$\begin{array}{r} 9\frac{5}{9} - 6\frac{5}{6} \\ \hline \end{array}$$

$$2\frac{13}{18}$$

7. 
$$\begin{array}{r} 6\frac{1}{4} - 3\frac{1}{3} \\ \hline \end{array}$$

$$2\frac{11}{12}$$

9. 
$$\begin{array}{r} 8\frac{2}{7} - 7\frac{1}{3} \\ \hline \end{array}$$

$$\frac{20}{21}$$

6. 
$$\begin{array}{r} 4\frac{3}{4} - 2\frac{2}{3} \\ \hline \end{array}$$

$$2\frac{1}{12}$$

8. 
$$\begin{array}{r} 5\frac{1}{5} - 3\frac{7}{8} \\ \hline \end{array}$$

$$1\frac{13}{40}$$

10. 
$$\begin{array}{r} 2\frac{9}{10} - 2\frac{1}{3} \\ \hline \end{array}$$

$$\frac{17}{30}$$

**Strategy Practice** The table shows the length and width of several kinds of bird eggs.**Egg Sizes**

Bird	Length	Width
Canada goose	$3\frac{2}{5}$ in.	$2\frac{3}{10}$ in.
Robin	$\frac{3}{4}$ in.	$\frac{3}{5}$ in.
Turtledove	$1\frac{1}{5}$ in.	$\frac{9}{10}$ in.
Raven	$1\frac{9}{10}$ in.	$1\frac{3}{10}$ in.

11. How much longer is the Canada goose egg than the raven egg?

$$1\frac{1}{2} \text{ in. longer}$$

12. How much wider is the turtledove egg than the robin egg?

$$\frac{3}{10} \text{ in. wider}$$

13. Which is the difference of
- $21\frac{15}{16} - 18\frac{3}{4}$
- ?

A  $2\frac{7}{16}$

B  $2\frac{9}{16}$

C  $3\frac{3}{16}$

D  $3\frac{9}{16}$

- 14.
- Explain It**
- Explain why it is necessary to rename
- $4\frac{1}{4}$
- if you subtract
- $\frac{3}{4}$
- from it.

**Sample answer:** You cannot subtract  $\frac{3}{4}$  from  $\frac{1}{4}$ , so you must borrow 1 whole from the 4 and rename  $4\frac{1}{4}$  as  $3\frac{5}{4}$ .

## Problem Solving: Try, Check, and Revise

For questions 1 and 2, suppose you have  $2 \times 2$  ft,  $3 \times 3$  ft,  $4 \times 4$  ft, and  $5 \times 5$  ft tiles.

1. Which tiles can be used to cover a  $12 \times 12$  ft floor?  **$2 \times 2$ ,  $3 \times 3$ , and  $4 \times 4$**

2. Which tiles can be used to cover a  $9 \times 9$  ft floor?  **$3 \times 3$**

3. What size rectangular floor can be completely covered by using only  $3 \times 3$  ft tiles OR  $5 \times 5$  ft tiles? Remember, you can't cut tiles or combine the two tile sizes.

**Sample:  $15 \text{ ft} \times 45 \text{ ft}$ ,  $30 \text{ ft} \times 60 \text{ ft}$**

4. Adult tickets cost \$6 and children's tickets cost \$4. Mrs. LeCompte says that she paid \$30 for tickets, for both adults and children. How many of each ticket did she buy?

**$3$  adults and  $3$  children OR  $1$  adult and  $6$  children**

5. **Reasoning** The sum of two odd numbers is 42. They are both prime numbers, and the difference of the two numbers is 16. What are the two numbers?

A 20 and 22

B 17 and 25

C 9 and 33

**D** 13 and 29

6. **Explain It** Marcy wants to put tiles on a bathroom floor that measures  $10 \text{ ft} \times 12 \text{ ft}$ . What kind of square tiles should she buy to tile her floor? Explain.

**Sample: She can buy  $2 \times 2$  ft tiles to tile her floor.**

# Multiplying Fractions and Whole Numbers

Find each product.

- |   |   |   |
|---|---|---|
| 1. $\frac{1}{4}$ of 96 = <u>24</u>      | 2. $\frac{4}{7}$ of 28 = <u>16</u>          | 3. $\frac{3}{4} \times 72 =$ <u>54</u>    |
| 4. $45 \times \frac{3}{9} =$ <u>15</u>  | 5. $56 \times \frac{7}{8} =$ <u>49</u>      | 6. $42 \times \frac{3}{7} =$ <u>18</u>    |
| 7. $\frac{1}{2}$ of 118 = <u>59</u>     | 8. $\frac{3}{8}$ of 56 = <u>21</u>          | 9. $\frac{1}{10} \times 400 =$ <u>40</u>  |
| 10. $84 \times \frac{1}{6} =$ <u>14</u> | 11. $64 \times \frac{5}{16} =$ <u>20</u>    | 12. $40 \times \frac{11}{20} =$ <u>22</u> |
| 13. $\frac{5}{8}$ of 48 = <u>30</u>     | 14. $\frac{1}{7}$ of 77 = <u>11</u>         | 15. $\frac{4}{5} \times 90 =$ <u>72</u>   |
| 16. $42 \times \frac{3}{14} =$ <u>9</u> | 17. $72 \times \frac{5}{8} =$ <u>45</u>     | 18. $18 \times \frac{2}{3} =$ <u>12</u>   |
| 19. $\frac{5}{6} \times 84 =$ <u>70</u> | 20. $\frac{11}{12} \times 144 =$ <u>132</u> | 21. $\frac{6}{7} \times 42 =$ <u>36</u>   |

22. **Strategy Practice** Complete the table by writing the product of each expression in the box below it. Use a pattern to find each product. Explain the pattern.

$\frac{1}{2} \times 32$	$\frac{1}{4} \times 32$	$\frac{1}{8} \times 32$	$\frac{1}{16} \times 32$
<b>16</b>	<b>8</b>	<b>4</b>	<b>2</b>

**Pattern: divide by 2**

23. **Reasoning** If  $\frac{1}{2}$  of 1 is  $\frac{1}{2}$ , what is  $\frac{1}{2}$  of 2, 3, and 4? 1,  $1\frac{1}{2}$ , and 2
24. Which is  $\frac{2}{3}$  of 225?
- A 75      B 113      **C 150**      D 450
25. **Explain It** Explain why  $\frac{1}{2}$  of 2 equals one whole.

$$\frac{1}{2} \text{ of } 2 = \frac{1}{2} \times 2 = \frac{2}{2} = 1$$

# Multiplying Two Fractions

Write the multiplication problem that each model represents then solve. Put your answer in simplest form.

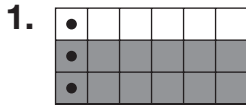

$$\frac{2}{3} \times \frac{1}{6} = \frac{2}{18} = \frac{1}{9}$$

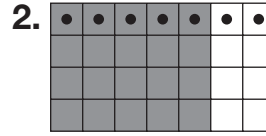

$$\frac{5}{7} \times \frac{1}{4} = \frac{5}{28}$$

Find each product. Simplify if possible.

3.  $\frac{7}{8} \times \frac{4}{5} = \frac{7}{10}$

5.  $\frac{1}{6} \times \frac{2}{5} = \frac{1}{15}$

7.  $\frac{2}{9} \times \frac{1}{2} = \frac{1}{9}$

9.  $\frac{3}{8} \times \frac{4}{9} = \frac{1}{6}$

11.  $\frac{2}{3} \times \frac{5}{6} \times 14 = 7\frac{7}{9}$

4.  $\frac{3}{7} \times \frac{2}{3} = \frac{2}{7}$

6.  $\frac{2}{7} \times \frac{1}{4} = \frac{1}{14}$

8.  $\frac{3}{4} \times \frac{1}{3} = \frac{1}{4}$

10.  $\frac{1}{5} \times \frac{5}{6} = \frac{1}{6}$

12.  $\frac{1}{2} \times \frac{1}{3} \times \frac{1}{4} = \frac{1}{24}$

13. **Algebra** If  $\frac{4}{5} \times \blacksquare = \frac{2}{5}$ , what is  $\blacksquare$ ?  $\frac{1}{2}$

14. Ms. Shoemaker's classroom has 35 desks arranged in 5 by 7 rows. How many students does Ms. Shoemaker have in her class if there are  $\frac{6}{7} \times \frac{4}{5}$  desks occupied? **24 students**

15. Which does the model represent?

A  $\frac{3}{8} \times \frac{3}{5}$

B  $\frac{7}{8} \times \frac{2}{5}$

**C**  $\frac{3}{5} \times \frac{5}{8}$

D  $\frac{4}{8} \times \frac{3}{5}$

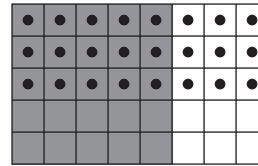

16. **Explain It** Describe a model that represents  $\frac{3}{3} \times \frac{4}{4}$ .

**Each fraction represents one whole, so the model would be completely shaded in for both fractions.**

# Multiplying Mixed Numbers

Estimate the product. Then complete the multiplication.

$$1. 5\frac{4}{5} \times 7 = \frac{29}{5} \times \frac{7}{1} = 40\frac{3}{5}$$

$$2. 3\frac{2}{3} \times 5\frac{1}{7} = \frac{11}{3} \times \frac{36}{7} = 18\frac{6}{7}$$

Estimate. Then find each product. Simplify.

$$3. 4\frac{3}{5} \times \frac{2}{3} = 3\frac{1}{15}$$

$$4. 6 \times 2\frac{2}{7} = 13\frac{5}{7}$$

$$5. 7\frac{4}{5} \times 2\frac{1}{3} = 18\frac{1}{5}$$

$$6. 3\frac{3}{4} \times 2\frac{4}{5} = 10\frac{1}{2}$$

$$7. 2\frac{1}{5} \times \frac{7}{8} = 1\frac{37}{40}$$

$$8. 6\frac{1}{3} \times 1\frac{5}{6} = 11\frac{11}{18}$$

$$9. 1\frac{4}{5} \times 1\frac{1}{3} \times 1\frac{3}{4} = 4\frac{1}{5}$$

$$10. \frac{3}{4} \times 2\frac{2}{3} \times 5\frac{1}{5} = 10\frac{2}{5}$$

11. **Algebra** Write a mixed number for  $p$  so that  $3\frac{1}{4} \times p$  is more than  $3\frac{1}{4}$ .

**Answers will vary. Any mixed number greater than 1 will work.**

12. A model house is built on a base that measures  $9\frac{1}{4}$  in. wide and  $8\frac{4}{5}$  in. long. What is the total area of the model house's base?

$$81\frac{2}{5} \text{ in}^2$$

13. Which is  $1\frac{3}{4}$  of  $150\frac{1}{2}$ ?

A 263

B  $263\frac{1}{8}$

**C**  $263\frac{3}{8}$

D  $264\frac{3}{8}$

14. **Explain It** Megan's dog Sparky eats  $4\frac{1}{4}$  cups of food each day. Explain how Megan can determine how much food to give Sparky if she needs to feed him only  $\frac{2}{3}$  as much. Solve the problem.

**Megan would multiply  $4\frac{1}{4}$  c by  $\frac{2}{3}$  to find  $2\frac{5}{6}$  c.**



# Relating Division to Multiplication of Fractions

In **1** and **2**, use the picture to find each quotient.



1. How many thirds are in 1?

**3**

2. How many thirds are in 7?

**21**

In **3** and **4**, draw a picture to find each quotient.

3.  $3 \div \frac{1}{2}$

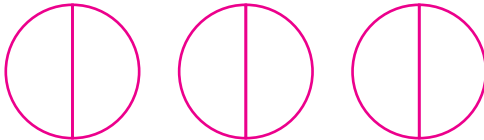

**6**

4.  $4 \div \frac{1}{8}$

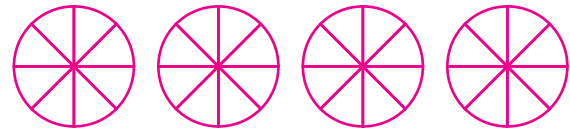

**32**

In **5** and **6**, use multiplication to find each quotient.

5.  $6 \div \frac{1}{3}$

**$6 \times 3 = 18$**

6.  $5 \div \frac{1}{10}$

**$5 \times 10 = 50$**

7. Julie bought 3 yards of cloth to make holiday napkin rings. If she needs  $\frac{3}{4}$  of a yard to make each ring, how many rings can she make?

**4**

8. **Reasoning** When you divide a whole number by a fraction with a numerator of 1, explain how you can find the quotient.

**Sample answer:**  
**You can multiply the whole number by the denominator of the fraction.**

## Problem Solving: Draw a Picture and Write an Equation

Solve each problem. Draw a picture to show the main idea for each problem. Then write an equation and solve it. Write the answer in a complete sentence. **Check student's drawings.**

1. Bobby has 3 times as many model spaceships as his friend Sylvester does. Bobby has 21 spaceships. How many model spaceships does Sylvester have?

**$21 \div 3 = x, x = 7$ ; Sylvester has 7 spaceships.**

2. Dan saved \$463 over the 12 weeks of summer break. He saved \$297 of it during the last 4 weeks. How much did he save during the first 8 weeks?

**$\$463 - \$297 = x, x = \$166$ ; Dan saved \$166 during the first 8 weeks.**

3. **Strategy Practice** Use a separate sheet of paper to show the main idea for the following problem. Choose the answer that solves the problem correctly.

A box of peanut-butter crackers was divided evenly among 6 children. Each child got 9 crackers. How many crackers were in the box?

- A** 54      **B** 48      **C** 39      **D** 36

4. **Explain It** Why is it helpful to draw a picture when attempting to solve an equation?

**Sample answer: Drawing can give you a picture of the problem that will help you create the right equation to solve the problem.**

# Using Customary Units of Length

Measure each segment to the nearest inch,  $\frac{1}{2}$  inch,  $\frac{1}{4}$  inch, and  $\frac{1}{8}$  inch.

1.   
 $2 \text{ in.}; 2\frac{1}{2} \text{ in.}; 2\frac{1}{4} \text{ in.}; 2\frac{1}{4} \text{ in.}$

2.   
 $2 \text{ in.}; 1\frac{1}{2} \text{ in.}; 1\frac{1}{2} \text{ in.}; 1\frac{1}{2} \text{ in.};$

3. **Reasoning** Sarah gave the same answer when asked to round  $4\frac{7}{8}$  in. to the nearest  $\frac{1}{2}$  inch and the nearest inch. Explain why Sarah is correct.

**Sample answer: 5 in. is the nearest inch and  $\frac{1}{2}$  in. to  $4\frac{7}{8}$  in.**

4. Estimate the length of your thumb. Then use a ruler to find the actual measure.

**Answers will vary.**

5. **Estimation** A real motorcycle is 18 times as large as a model motorcycle. If the model motorcycle is  $5\frac{1}{16}$  in. long, about how long is the real motorcycle?

A 23 in.

B 48 in.

**C** 90 in.

D 112 in.

6. **Explain It** If a line is measured as  $1\frac{4}{8}$  in. long, explain how you could simplify the measurement.

**Sample answer: I could simplify  $1\frac{4}{8}$  to  $1\frac{1}{2}$  by dividing the numerator and denominator by 4.**

# Using Metric Units of Length

Measure each segment to the nearest centimeter then to the nearest millimeter.

1. 

2. 

**5 cm, 54 mm**

**4 cm, 39mm**

**Number Sense** Some of the events at an upcoming track and field meet are shown at the right.

### Track and Field Events

50-m dash
1,500-m dash
400-m dash
100-m dash

3. In which event or events do athletes travel more than a kilometer?

**1,500-m dash**

4. In which event or events do athletes travel less than a kilometer?

**50-m dash, 100-m dash, 400-m dash**

5. **Reasonableness** Which unit would be most appropriate for measuring the distance from Chicago to Miami?

**A** mm

**B** cm

**C** m

**D** km

6. **Explain It** List one item in your classroom you would measure using centimeters and one item in the classroom you would measure using meters.

**Check students' work.**

# Perimeter

Find the perimeter of each figure.

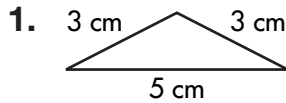

**11 cm**

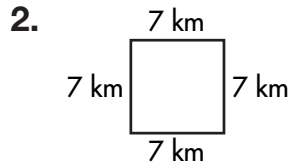

**28 km**

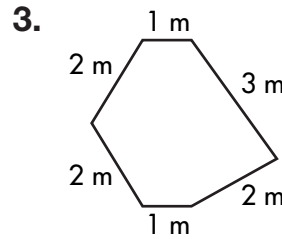

**11 m**

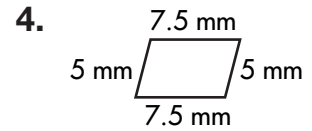

**25 mm**

5. **Number Sense** What is the perimeter of a square if one of the sides is 3 mi? **12 mi**

Use the dimensions of the football field shown at the right for 6 and 7.

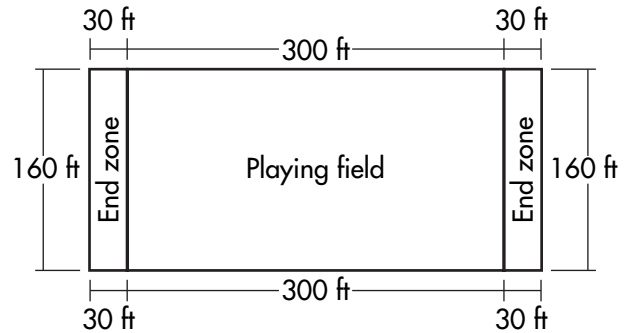

6. What is the perimeter of the entire football field including the end zones?

**1,040 ft**

7. What is the perimeter of each end zone?

**380 ft**

8. What is the perimeter of this figure?

- A** 18 m                      **C** 12 m  
**B** 15 ft                      **D** 10 ft

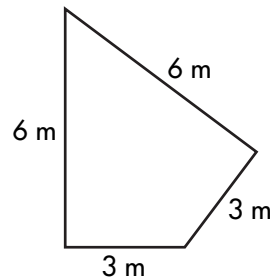

9. **Explain It** A rectangle has a perimeter of 12 m. If each side is a whole number of meters, what are the possible dimensions for the length and width? List them and explain your answer.

**1 and 5, 2 and 4, 3 and 3, 4 and 2, 5**

**and 1. If the perimeter is 12 m, the**

**length and width must add to 6 m.**

# Areas of Squares and Rectangles

Find the area of each figure.

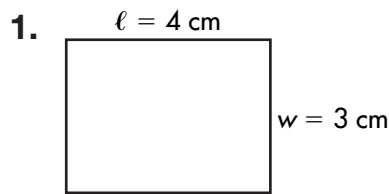

$$\underline{12 \text{ cm}^2}$$

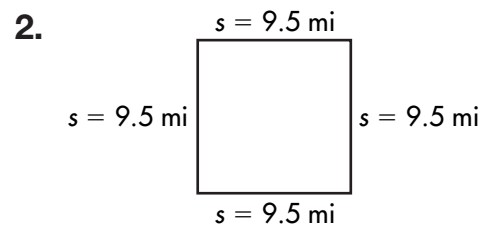

$$\underline{90.25 \text{ mi}^2}$$

3. a rectangle with sides 6.5 km and 3.4 km

$$\underline{22.1 \text{ km}^2}$$

4. a square with a side of 10.2 ft

$$\underline{104.04 \text{ ft}^2}$$

5. a rectangle with sides 9 m and 9.2 m

$$\underline{82.8 \text{ m}^2}$$

6. **Number Sense** Which units would you use to measure the area of a rectangle with  $l = 1$  m and  $w = 34$  cm? Explain.

**Sample answer: Centimeters; I would convert the 1 m to centimeters.**

7. Which of the following shapes has an area of  $34 \text{ ft}^2$ ?

- A** a square with  $s = 8.5$  m
- B** a rectangle with  $l = 15$  ft,  $w = 2$  ft
- C** a square with  $s = 16$  ft
- (D)** a rectangle with  $l = 17$  ft,  $w = 2$  ft

8. **Explain It** The area of a square is  $49 \text{ m}^2$ . What is the length of one of its sides? Explain how you solved this problem.

**7 m; Sample answer: The length of each side of a square is equal. The factors of 49 are 1, 7, 7, and 49, so each side must be 7 m.**

# Area of Parallelograms

Find the area of each parallelogram.

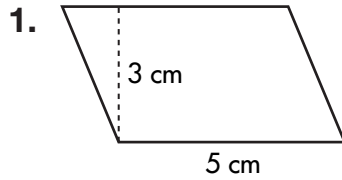

**$15 \text{ cm}^2$**

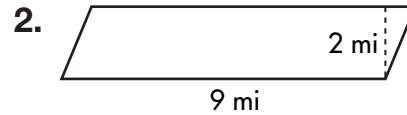

**$18 \text{ mi}^2$**

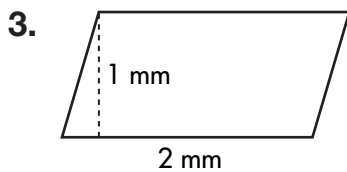

**$2 \text{ mm}^2$**

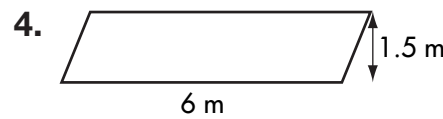

**$9 \text{ m}^2$**

**Algebra** Find the missing measurement for the parallelogram.

5.  $A = 34 \text{ in}^2$ ,  $b = 17 \text{ in.}$ ,  $h =$   **$2 \text{ in.}$**

6. List three sets of base and height measurements for parallelograms with areas of 40 square units.

**Sample answer:  $b = 2$ ,  $h = 20$ ;  $b = 4$ ,** **$h = 10$ ;  $b = 5$ ,  $h = 8$** 

7. Which is the height of the parallelogram?

- A 55 m  
 B 55.5 m  
 C 5 m  
**D 5.5 m**

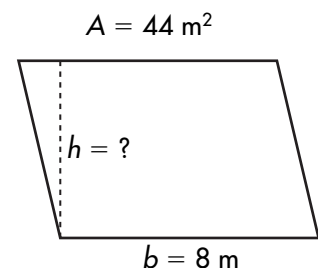

- 8.
- Explain It**
- What are a possible base and height for a parallelogram with an area of
- $45 \text{ ft}^2$
- if the base and height are a whole number of feet? Explain how you solved this problem.

**Sample answer: 9 ft and 5 ft; 9 and 5 are factors of 45, so a base of 9 ft and height of 5 ft would result in an area of  $45 \text{ ft}^2$ .**

# Area of Triangles

Find the area of each triangle.

1.

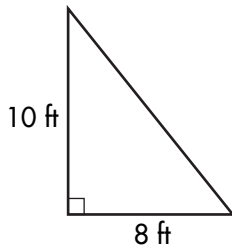

**40 ft<sup>2</sup>**

2.

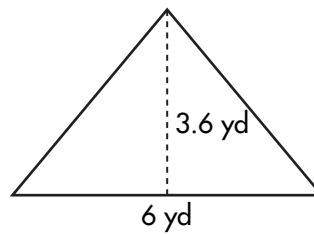

**10.8 yd<sup>2</sup>**

3.

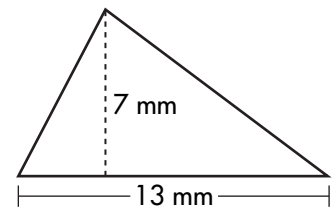

**45.5 mm<sup>2</sup>**

4. **Number Sense** What is the base measurement of a triangle with an area of  $30 \text{ m}^2$  and a height of 10 m?

**6 m**

**Algebra** Find the missing measurement for each triangle.

5.  $A = 36 \text{ mi}^2$ ,  $b =$  **6 mi**,  $h = 12 \text{ mi}$

6.  $A =$  **45 mm<sup>2</sup>**,  $b = 12 \text{ mm}$ ,  $h = 7.5 \text{ mm}$

7. List three sets of base and height measurements for triangles with areas of 30 square units.

**Sample answer:  $b = 4$ ,  $h = 15$ ;  $b = 6$ ,  $h = 10$ ;  $b = 8$ ,  $h = 7.5$**

8. Which is the height of the triangle?

**A** 4.5 ft

**C** 8 ft

**B** 6 ft

**D** 9 ft

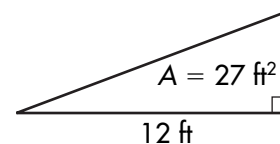

9. **Explain It** Can you find the base and height measurements for a triangle if you know that the area is 22 square units? Explain why or why not.

**No; Sample answer: You need to know at least 2 of the measurements of the base, the height, and the area.**



# Circles and Circumference

In 1 through 3, use circle X to identify the following.

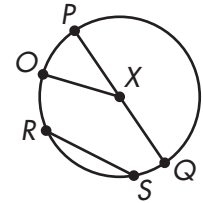

1. a diameter

 $\overline{QP}$ 

2. two chords

 $\overline{RS}$  and  $\overline{QP}$ 

3. a central angle

 $\angle QXP,$   
 $\angle QXO, PXO$ In 4 through 9, find the circumference. Use 3.14 for  $\pi$ .4.  $d = 20$  in. $62.8$  in.5.  $d = 5$  yd $15.7$  yd6.  $d = 9$  cm $28.26$  cm7.  $r = 3.20$  in. $20.1$  in.8.  $r = 13$  ft $81.64$  ft9.  $r = 20$  yd $125.6$  yd

10. A round swimming pool has a radius of 8 meters. What is its circumference?

 $50.24$  meters11. **Estimation** The length of the diameter of a circle is 11 centimeters. Is the circumference more or less than 33 centimeters? Explain. $3 \times 11 = 33,$  and  $\pi$  is greater than 3,so  $\pi \times 11 > 33$ 

12. Which equation can be used to find the circumference of a circle with a radius that measures 10 feet?

A  $C = 2 \times \pi \times 20$

C  $C = \pi \times 1.0$

B  $C = 2 \times \pi \times 10$

D  $C = \pi \times 10$

# Problem Solving: Draw a Picture and Make an Organized List

Draw a picture and make a list to solve.

1. Erica painted a picture of her dog. The picture has an area of  $3,600 \text{ cm}^2$  and is square. She has placed the picture in a frame that is 5 cm wide. What is the perimeter of the picture frame?

**280 cm**

---

2. The new playground at Middledale School will be enclosed by a fence. The playground will be rectangular and will have an area of  $225 \text{ yd}^2$ . The number of yards on each side will be a whole number. What is the least amount of fencing that could be required to enclose the playground?

**60 yd**

---

3. **Reasoning** Evan is thinking of a 3-digit odd number that uses the digit 7 twice. The digit in the tens place is less than one. What is the number?

**A** 707

**B** 717

**C** 770

**D** 777

4. **Explain It** Explain how you solved Exercise 3.

**Check students' work.**

---

---

---

**Solids**

For 1 through 3, use the solid at the right.

1. Name the vertices.

**A, B, C, D**

2. Name the faces.

**ABC, ABD, ACD, BCD**

3. Name the edges.

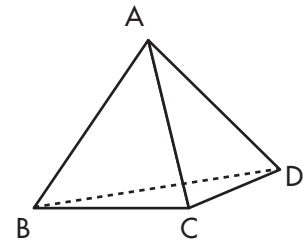
**AB, AC, AD, BC, BD, CD**

For 4 through 6, tell which solid figure each object resembles.

4.

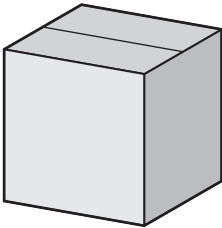
**Cube**

5.

**Cylinder**

6.

**Rectangular prism**

7. Which term best describes the figure at the right?

A Cone

 B Triangular prism

C Pyramid

D Rectangular prism

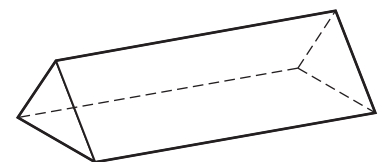

- 8.
- Explain It**
- How many vertices does a cone have? Explain.

**One; the circular base does not have any vertices but every point on the circle meets at one point, the vertex, outside the base.**

# Relating Shapes and Solids

For 1 and 2, predict what shape each net will make.

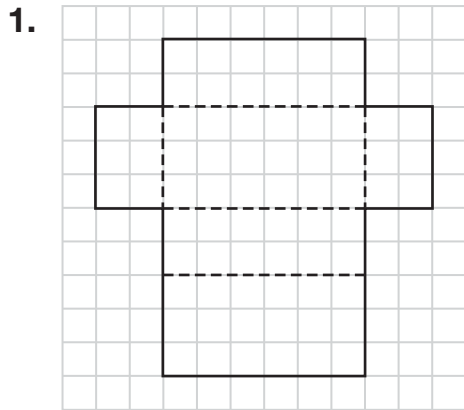

Rectangular prism

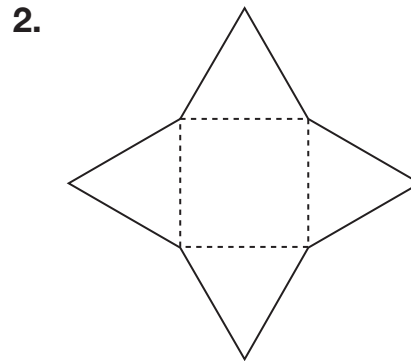

Square pyramid

**Reasoning** For 3 through 5, tell which solid figures could be made from the descriptions given.

3. A net that has 6 squares
4. A net that has 4 triangles
5. A net that has 2 circles and a rectangle
6. Which solid can be made by a net that has exactly one circle in it?

Cube

Triangular pyramid

Cylinder

- A** Cone      **B** Cylinder      **C** Sphere      **D** Pyramid

7. **Explain It** Draw a net for a triangular pyramid. Explain how you know your diagram is correct.

Sample answer: The  
4 equilateral triangles  
fold into a triangular  
pyramid.

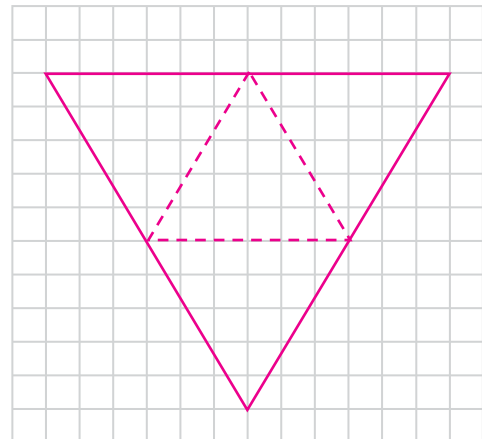

# Surface Area

Find the surface area of each rectangular prism.

1.

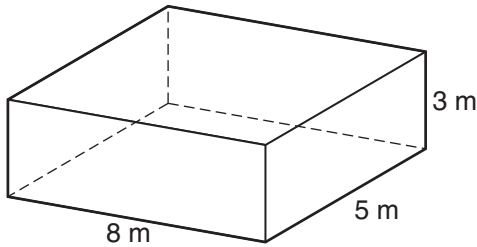

$$\underline{158 \text{ m}^2}$$

2.

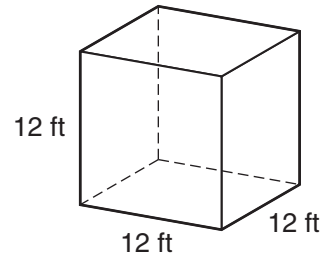

$$\underline{864 \text{ ft}^2}$$

**Strategy Practice** Music and computer CDs are often stored in plastic cases called jewel cases.

3. One size of jewel case is  $140 \text{ mm} \times 120 \text{ mm} \times 4 \text{ mm}$ . What is the surface area of this jewel case?

$$\underline{35,680 \text{ mm}^2}$$

4. A jewel case that holds 2 CDs is  $140 \text{ mm} \times 120 \text{ mm} \times 9 \text{ mm}$ . What is the surface area of this jewel case?

$$\underline{38,280 \text{ mm}^2}$$

5. What is the surface area of a rectangular prism with the dimensions 3 in. by 4 in. by 8 in.?

A 96 in<sup>2</sup>

B 112 in<sup>2</sup>

C 136 in<sup>2</sup>

D 152 in<sup>2</sup>

6. **Explain It** Explain why the formula for finding the surface area of a rectangular prism is helpful.

**Possible answer: the formula gives the total area of a solid rectangular shape that needs to be covered or painted.**

# Views of Solids

For **1** and **2**, draw front, side, and top views of each stack of unit blocks.

1.

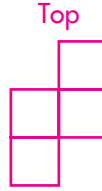
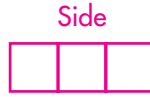
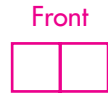
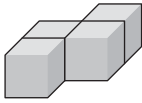

2.

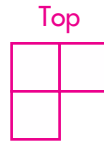
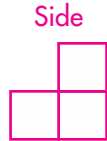
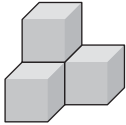

3. **Reasoning** In the figure for Exercise **2**, how many blocks are not visible?

**1**

4. In the figure at the right, how many unit blocks are being used?

- A 8
- B 9
- C 10**
- D 11

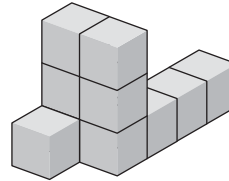

5. **Explain It** A figure is made from 8 unit blocks. It is 3 units tall. What is the maximum length the figure could be? Explain.

**The maximum length is 6, because 2 are used to give the figure height.**

# Volume

Find the volume of each rectangular prism.

1. base area
- $56 \text{ in}^2$
- , height 6 in.

**$336 \text{ in}^3$**

2. base area
- $32 \text{ cm}^2$
- , height 12 cm

**$384 \text{ cm}^3$**

3. base area
- $42 \text{ m}^2$
- , height 8 m

**$336 \text{ m}^3$**

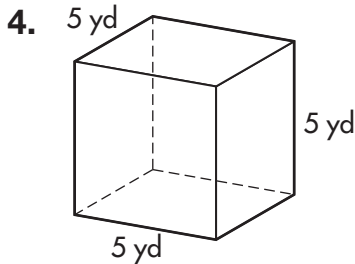

**$125 \text{ yd}^3$**

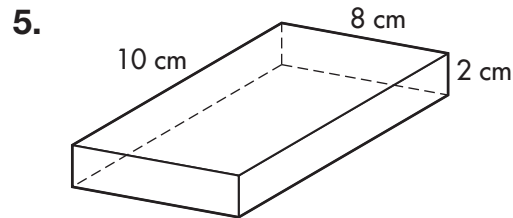

**$160 \text{ cm}^3$**

- 6.
- Algebra**
- What is the height of a solid with a volume of
- $120 \text{ m}^3$
- and base area of
- $30 \text{ m}^2$
- ?

**$4 \text{ m}$**

Michael bought some cereal at the grocery store.

7. What is the base area of the box?

**$28 \text{ in}^2$**

8. What is the volume of the box?

**$364 \text{ in}^3$**

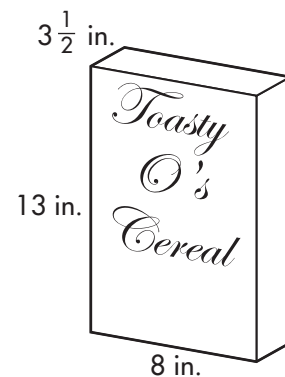

9. What is the base area of this figure?

A  $3.2 \text{ m}^2$

C  $320 \text{ m}^2$

**B**  $32 \text{ m}^2$

D  $3,200 \text{ m}^2$

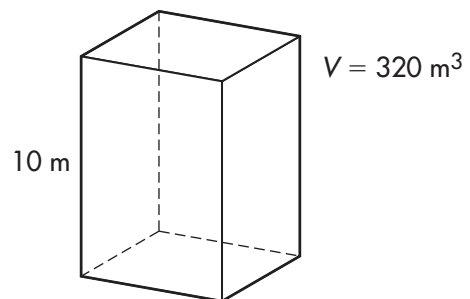

- 10.
- Explain It**
- Explain how you would find the base area of a rectangular prism if you know the volume and the height.

**Sample answer: Divide the volume by the height to find the base area.**

# Irregular Shapes and Solids

For 1 and 2, find the area of the irregular shape.

1.

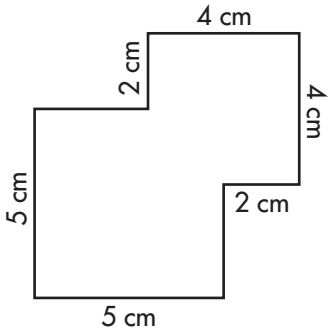

**37 cm<sup>2</sup>**

2.

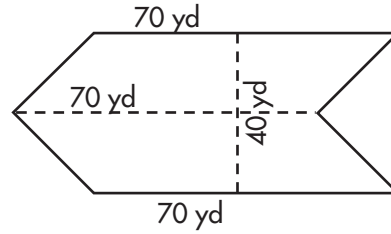

**2,800 yd<sup>2</sup>**

For 3 and 4, find the volume of the irregular solid.

3.

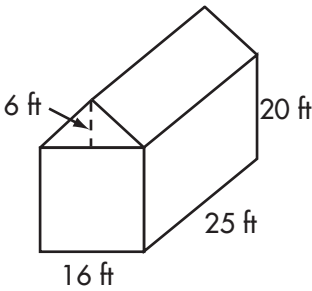

**9,200 ft<sup>3</sup>**

4.

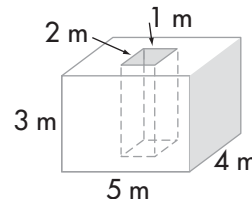

**54 m<sup>3</sup>**

5. What is the area of this irregular shape?

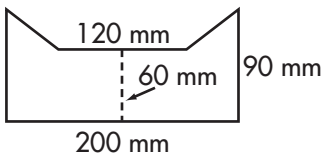

- A 1,200 mm<sup>2</sup>      **C** 13,200 mm<sup>2</sup>  
 B 12,000 mm<sup>2</sup>      D 14,400 mm<sup>2</sup>

6. **Explain It** When do you find an area or volume by separating the figure into smaller figures?

**When the figure is irregular**



# Problem Solving: Use Objects and Solve a Simpler Problem

Use objects to help you solve a simpler problem. Use the solution to help you solve the original problem.

1. **Number Sense** Six people can be seated at a table. If two tables are put together, 10 people can be seated. How many tables are needed to make a long table that will seat 22 people?

**5 tables**

2. Donna is building a large cube that will have 5 layers, each with 5 rows of 5 small cubes. How many small cubes will the larger cube contain?

**$5 \times 5 \times 5 = 125$**

3. **Strategy Practice** Jerome's job duties include feeding the fish. There are 5 kinds of fish that he feeds: guppies, zebra danios, betas, platys, and neon tetras.

Use the following clues to find the order in which Jerome feeds them.

- Jerome feeds the guppies third.
- Jerome does not feed the betas right before or right after the guppies.
- Jerome feeds the zebra danios last.
- Jerome feeds the platys after the betas.

**A** guppies, zebra danios, betas, platys, and neon tetras

**B** betas, platys, guppies, neon tetras, zebra danios

**C** neon tetras, zebra danios, guppies, platys, betas

**D** betas, guppies, platys, neon tetras, zebra danios

4. **Explain It** Suppose Ann is placing bowling pins in the following manner: 1 pin in the first row, 2 pins in the second row, 3 pins in the third row, and so on. How many pins will she use if she has 5 rows in her placement? Explain.

**$1 + 2 + 3 + 4 + 5 = 15$**

# Customary Units of Capacity

Which unit(s) of capacity would be most reasonable to measure each?

1. barrel of oil gal
2. can of applesauce cup or fl oz
3. individual carton of orange juice cup or pt

Give the amount of liquid in each container. Use a fraction if necessary.



2 pt



4 qt

6. **Reasoning** Do 1 gallon and 8 pints represent the same amount?

- A** No, 8 pints is 8 times the amount of 1 gallon.  
**B** No, 1 gallon is equal to 4 quarts.  
 **C** Yes, 1 gallon is equal to 4 quarts, which is equal to 8 pints.  
**D** Yes, 8 pints is equal to 8 cups, which is equal to 1 gallon.

7. **Explain It** If you only needed 1 c of milk, what is your best choice at the grocery store—a quart container, a pint container, or a  $\frac{1}{2}$  gal container? Explain.

**A pint container (16 fl oz) is closer to a cup (8 fl oz) than the other measures.**

# Metric Units of Capacity

**Estimation** Which unit of capacity would be most reasonable to measure each?

- bottle of water: 1 mL or 1 L
- bottle cap: 20 mL or 20 L
- swimming pool: 80,000 mL or 80,000 L

**1 L**

**20 mL**

**80,000 L**

Give the amount of liquid in each container.

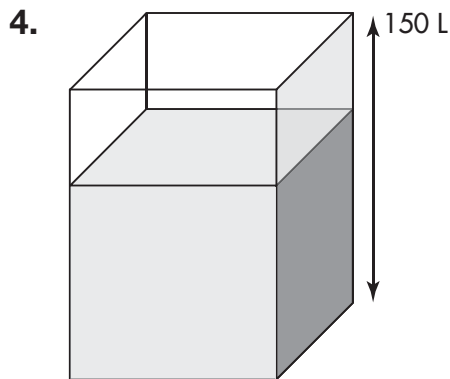

**100 L**

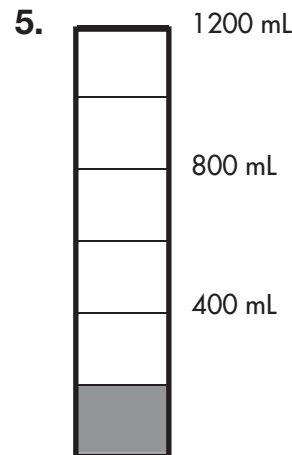

**200 mL**

6. **Reasonableness** In a science fair project, you test four different-sized containers of water: 1 L, 2 L, 4 L, and 5 L. Which of the following expresses these capacities in milliliters?

- A 1 mL, 2 mL, 4 mL, 5 mL  
 B 10 mL, 20 mL, 40 mL, 50 mL  
 C 100 mL, 200 mL, 400 mL, 500 mL  
 D 1,000 mL, 2,000 mL, 4,000 mL, 5,000 mL

7. **Explain It** Tell whether you would use multiplication or division to convert milliliters to liters. Explain your answer.

**Sample answer: I would divide by**

**1,000 to convert milliliters to liters, because 1,000 mL = 1 L.**

# Units of Weight and Mass

Which customary unit of weight would be best to measure each weight?

1. newborn baby     **pound**
2. earrings     **ounce**

Which metric unit of mass would be better to measure each mass?

3. necktie     **gram**
4. 5 math textbooks     **kilogram**

Which mass or weight is most reasonable for each?

5. laptop computer: 5 lb or 5 mg     **5 lb**
6. dozen donuts: 1 oz or 1 kg     **1 kg**

7. **Reasonableness** Which unit would you use to weigh a garbage truck?

- A** ton                      **B** kilogram                      **C** pound                      **D** milligram

8. **Explain It** Did you know that there is litter in outer space? Humans exploring space have left behind bags of trash, bolts, gloves, and pieces of satellites. Suppose there are about 4,000,000 lb of litter in orbit around Earth. About how many tons of space litter is this? Explain how you found your answer.

    **2,000 T**

# Converting Customary Units

In 1 through 9, convert each measurement. You may need to convert more than once.

1. 3,520 yd = 2 mi

2. 10 ft 5 in. = 125 in.

3. 3 T = 96,000 oz

4. 4 gal = 64 c

5. 2 gal = 256 fl oz

6. 6 yd 2 ft = 240 in.

7. 6 qt 1 pt = 13 pt

8. 40 qt = 10 gal

9. 48 ft = 16 yd

10. Jenny bought a gallon of orange juice. The recipe for punch calls for 2 quarts of juice. How many quarts will she have left over to drink at breakfast?

**2 qts left over**

11. **Algebra** Laura has a roll of ribbon. There are 20 yards of ribbon on the roll. What equation can Laura use to find the number of inches of ribbon on the roll?

**$n = 20 \times 36$**

12. Ramona drives a truck weighing 1 ton. She picks up 3 cows weighing 3,000 pounds total. How much do the truck and the cows weigh together?

A 50 lb

B 500 lb

C 5,000 lb

D 50,000 lb

13. **Explain It** If you want to convert pounds to ounces, do you multiply or divide?

**Sample answer: every pound contains 16 ounces. You multiply the number of pounds by 16 to find the number of ounces.**

# Converting Metric Units

In 1 through 6, convert each measurement.

1. 3,000 mm = 3 m

2. 8 km = 8,000 m

3. 6 m = 600 cm

4. 9.8 kg = 9,800 g

5. 20,000 mg = 20 g

6. 11,000 mL = 11 L

In 7 through 12, compare the measurements.

Use  $<$ ,  $>$ , or  $=$  for each  $\bigcirc$ .

7. 4,000 g  $<$  5 kg

8. 0.72 L  $>$  572 mL

9. 5.12 m  $=$  512 cm

10. 8 kg  $>$  5,000 g

11. 44 L  $=$  44,000 mL

12. 200 m  $>$  20,000 mm

13. A watering can holds 4.2 liters. If a small cactus requires 310 mL of water once every 3 weeks, how many of the same cactus plant can be watered at once without refilling the watering can?

**13 cactus plants**

14. **Critical Thinking** How do you convert kilometers to meters?

**Multiply by 1,000**

15. Jeremy's apartment building is 15 meters tall. How many centimeters is this?

A 1.5 cm

B 50 cm

**C 1,500 cm**

D 15,000 cm

16. **Explain It** Explain how to convert 24 kilograms to grams.

**Sample answer: Since  $1\text{ kg} = 1,000\text{ g}$ ,**

**multiply 24 kg by 1,000.  $24 \times 1,000 =$**

**24,000 grams**

# Elapsed Time

Find each elapsed time.

1. 9:59 P.M. to 10:45 P.M. 46 min

2. 1:45 P.M. to 5:38 P.M. 3 h 53 min

3.    
A.M. A.M.

2 h 51 min

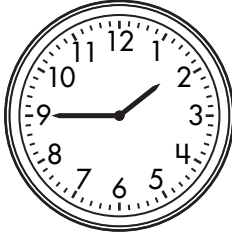
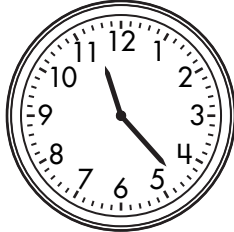
4.    
P.M. P.M.

9 h 38 min

Find the end time using the given elapsed time.

5. Start: 3:46 P.M. Elapsed: 2 h 20 min 6:06 P.M.

6. Add. 
$$\begin{array}{r} 2 \text{ h } 45 \text{ min} \\ + 3 \text{ h } 58 \text{ min} \\ \hline \end{array}$$

6 h 43 min

7. Add. 
$$\begin{array}{r} 6 \text{ h } 47 \text{ min} \\ + 5 \text{ h } 28 \text{ min} \\ \hline \end{array}$$

12 h 15 min

The White House Visitor Center is open from 7:30 A.M. until 4:00 P.M.

8. Tara and Miguel got to the Visitor Center when it opened, and spent 1 hour and 20 minutes there. At what time did they leave? 8:50 A.M.

9. Jennifer left the Visitor Center at 3:30 P.M. after spending 40 minutes there. At what time did she arrive? 2:50 P.M.

10. A football game lasted 2 hours and 37 minutes. It finished at 4:22 P.M. When did it start?

- A** 1:45 P.M.      **B** 1:55 P.M.      **C** 2:45 P.M.      **D** 2:50 P.M.

11. **Explain It** What is 1 hour and 35 minutes before 4:05 P.M.? Explain how you solved this problem.

Sample answer: 2:30 P.M.; I solved this problem using subtraction.

# Elapsed Time in Other Units

Find the elapsed time.

1. 9:50 P.M. to 4:00 A.M.

**6 h 10 min**

2. 5:15 A.M. to 2:15 P.M.

**9 h**

3. 10:00 P.M. to 4:45 A.M.

**6 h 45 min**

4. 6:30 P.M. to 5:10 A.M.

**10 h 40 min**

Find the end or start time.

5. Start time: 8:15 A.M.

Elapsed time: 30 h 20 min.

**End time: 2:35 p.m**

6. End time: 10:30 P.M.

Elapsed time: 13 h 30 min.

**Start time: 9:00 a.m**

7. **Number Sense** Krishan wakes up at 7:30 A.M. every morning. He spends 30 minutes getting ready, 6 hours at school, and 2 hours volunteering. Then he takes the bus for 15 minutes and arrives at his house. What time does he arrive at his house?

A 2:00 P.M.

B 3:45 P.M.

**C 4:15 P.M.**

D 5:45 P.M.

8. **Explain It** Emre left for a trip Sunday night at 10:00 P.M. He returned home Tuesday morning at 6:00 A.M. How many hours was he away on his trip? Explain how you found your answer.

**24 hours from Sunday to Monday 10 p.m.,  
and another 8 hours to Tues morning.**

**Total:  $24 + 8 = 32$  hours**



# Temperature Change

Write each temperature in Celsius and Fahrenheit.

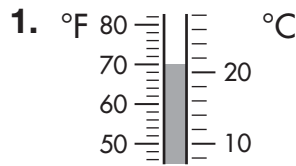

70°F, 21°C

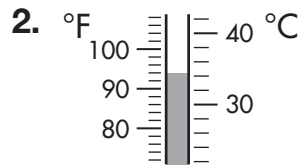

94°F, 34°C

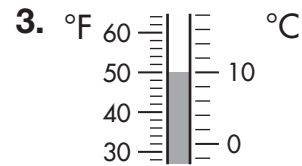

50°F, 10°C

Find each change in temperature.

4. 34°F to 67°F

33°F increase

5. 12°C to 7°C

5°C decrease

6. **Number Sense** Which is a smaller increase in temperature: a 5°F increase or a 5°C increase?

5°F is a smaller increase.

Information about the record high temperatures in four states is shown.

**Record High Temperature**

State	°F	°C
Alaska	100	38
Florida	109	43
Michigan	112	44
Hawaii	100	38

7. What is the difference between the record high temperature in Florida and the record high temperature in Alaska in °C?

5°C

8. What is the difference between the record high temperature in Michigan and the record high temperature in Florida in °F?

3°F

9. What is the difference between  $-6^{\circ}\text{C}$  and  $12^{\circ}\text{C}$ ?

A 6°C

B 12°C

**C** 18°C

D 19°C

10. **Explain It** Which is warmer,  $1^{\circ}\text{F}$  or  $1^{\circ}\text{C}$ ? Explain how you found this answer.

1°C is warmer. Sample answer: You can tell by looking at the thermometers.

# Problem Solving: Make a Table

Make a table to solve the problems.

1. The temperature in the room was  $55^{\circ}\text{F}$  at 8:00 A.M. Ed turned the heat on, and the temperature rose  $4^{\circ}\text{F}$  every 30 minutes. What was the temperature of the room at 11:30 A.M.?

**$83^{\circ}\text{F}$**

---

2. Charles can type 72 words per minute. He needs to type a paper with 432 words. How many minutes will it take Charles to type the paper?

**6 minutes**

---

3. **Number Sense** Yugita wakes up at 5:00 A.M. on Monday. Each day after that, she wakes up 17 minutes later. What time will she wake up on Friday?

A 5:17 A.M.

B 5:51 A.M.

C 6:08 A.M.

**D 6:25 A.M.**

4. **Explain It** Train A leaves from New York at 10:15 A.M. and arrives in New Haven at 12:23 P.M. Train B takes 2 hours to go from New York to New Haven, but takes a 20-minute rest break in the middle of the trip. Which train is faster? Explain.

**Train A. It takes 2 hours 8 minutes and**

---

**Train B takes 2 hours 20 minutes.**

---

# Solving Addition and Subtraction Equations

Solve and check each equation.

1.  $x + 4 = 16$       $x = 12$      2.  $t - 8 = 15$       $t = 23$

3.  $m - 9 = 81$       $m = 90$      4.  $7 + y = 19$       $y = 12$

5.  $k - 10 = 25$       $k = 35$      6.  $15 + b = 50$       $b = 35$

7.  $f + 18 = 20$       $f = 2$      8.  $w - 99 = 100$       $w = 199$

9.  $75 + n = 100$       $n = 25$      10.  $p - 40 = 0$       $p = 40$

11. Jennifer has \$14. She sold a notebook and pen, and now she has \$18. Solve the equation  $14 + m = 18$  to find how much money Jennifer received by selling the notebook and pen.

**\$4**

12. Kit Carson was born in 1809. He died in 1868. Use the equation  $1,809 + x = 1,868$  to find how many years Kit Carson lived.

**59 years**

13. **Strategy Practice** Which is the solution for  $y$  when  $y - 6 = 19$ ?

A 13

B 15

C 23

**D 25**

14. **Explain It** Nellie solved  $y - 3 = 16$ . Is her answer correct? Explain and find the correct answer if she is incorrect.

**No; Sample answer: Nellie****used the wrong operation.****She needed to use addition****to get the variable alone.****The correct answer is  $y = 19$ .**

$$y - 3 = 16$$

$$y = 13$$

Subtract 3

# Solving Multiplication and Division Equations

Solve each equation.

1.  $11y = 55$   **$y = 5$**

2.  $\frac{c}{9} = 6$   **$c = 54$**

3.  $150 = 25p$   **$p = 6$**

4.  $16 = \frac{w}{4}$   **$w = 64$**

5.  $\frac{k}{36} = 8$   **$k = 288$**

6.  $13d = 39$   **$d = 3$**

7.  $30 = 10x$   **$x = 3$**

8.  $\frac{m}{7} = 13$   **$m = 91$**

9.  $81 = 9t$   **$t = 9$**

10.  $5b = 30$   **$b = 6$**

11.  $20 = 4a$   **$a = 5$**

12.  $\frac{e}{80} = 2$   **$e = 160$**

13. **Reasoning** Antoinette divides 54 by 9 to solve an equation for  $y$ . One side of the equation is 54. Write the equation.

**$9y = 54$**

14. Adam is making a trout dinner for six people. He buys 48 oz of trout. How many ounces of trout will each person get?

**$6x = 48; x = 8$  oz each**

15. Which operation would you use to solve the equation  $19x = 646$ ?

A add 19

B subtract 17

**C** divide by 19

D multiply by 19

16. **Explain It** How would you use mental math to find  $m$  in the equation  $63\left(\frac{m}{63}\right) = 2$ ?

**Sample answer: Multiplying and dividing  $m$  by 63 undo each other. So the equation is  $m = 2$ .**

# Inequalities and the Number Line

Name three solutions of each inequality. Then graph each inequality on a number line.

1.  $b \geq 5$

**5, 6, 8**

2.  $s + 2 \leq 4$

**2, 1, 0**

3.  $x \leq 3$

**0, 1, 2, 3**

4.  $d - 1 \geq 6$

**8, 9, 10**

5. Lizette wants to read more books. Her goal is to read at least 2 books each month. Let  $m$  represent the number of books she will read in a year. Use  $m \geq 24$  to graph the number of books she plans to read on a number line.



6. **Estimation** Marcus is making cookies for his class. There are 26 students, and he wants to bring 3 cookies per student. On Sunday, he runs out of time and decides he must buy at least half the cookies and will make no more than half from scratch. Draw a graph to represent how many cookies he will make himself.



7. Which sentence is graphed on the line below?

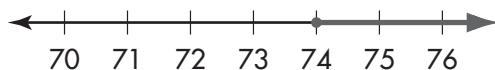

A  $m > 74$

**B**  $m \geq 74$

C  $m = 74$

D  $m < 74$

8. **Explain It** How do you know whether to use an open circle or a closed circle when graphing an inequality?

**Use an open circle when the inequality symbol is  $>$  or  $<$ . Use a closed circle when the inequality symbol is  $\geq$  or  $\leq$ .**

# Patterns and Equations

For 1 through 3, find a rule for each table. Write an equation for each rule.

1.

x	y
5	15
2	6
11	33
6	18

$$\underline{y = 3x}$$

2.

x	y
18	9
50	25
12	6
34	17

$$\underline{y = \frac{x}{2}}$$

3.

x	y
4	-4
8	0
12	4
16	8

$$\underline{y = x - 8}$$

4. **Reasoning** Write an equation that will give the answer  $y = 5$  when  $x = 12$ .

**Possible answer:  $y = x - 7$**

---

5. A farmer sells 200 apples at the market. The next week, he sells 345 apples. How many more apples did he sell the second week?

**$200 + x = 345$ ; 145 more apples**

---

6. In the equation  $y = x - 5$ , which numbers would you use for  $x$  if you wanted  $y < 0$ ?

**A** numbers  $< 10$    **(B)** 1, 2, 3, 4   **C** 6, 7, 8   **D** 10, 11, 12

7. **Explain It** If you know the rule for a table, how can you add pairs of numbers to the table?

**Sample answer: Use values for  $x$  not already in the table and solve for  $y$ .**

---

# Problem Solving: Draw a Picture and Write an Equation

Draw a picture, write, and solve an equation to answer the question.

- Suki and Amy made a total of 15 homemade holiday cards. Amy gave away 7 of them. How many cards did Suki give away?
- Ramon ate 3 more pieces of fruit today than he did yesterday. Today he ate 4 pieces. Write an equation to find out how many pieces of fruit he ate yesterday.

$$15 = 7 + p;$$

$$p = 8 \text{ cards for Suki to give away}$$

$$3 + p = 4;$$

$$p = 1 \text{ piece of fruit eaten yesterday}$$

- Critical Thinking** A total of 64 children are going on a field trip. If 14 of the children are girls, how many are boys?
- Naomi's class went to the museum. There are 16 students in her class. If the total cost of admission for the class was \$96, what does one admission to the museum cost?

$$14 + w = 64;$$

$$w = 50 \text{ boys}$$

$$\underline{\$96 = 16x; \$6 \text{ per admission}}$$

- Paul is in a 17-kilometer canoe race. He has just reached the 5-kilometer marker. Which of the following equations can you use to find out how many more kilometers he needs to paddle?

A  $k - 5 = 17$     **B**  $5 + k = 17$     C  $5 - k = 17$     D  $17 + 5 = k$

- Explain It** How can you use estimation to decide whether 24.50 multiplied by 4 is close to 100?

$$\underline{\text{Sample answer: } 24.50 \text{ is about } 25, \text{ and } 25 \times 4 \text{ is } 100.}$$

# Understanding Ratios

Use the chart below in 1 through 4 to write each ratio three ways.

**Mr. White's 3rd-Grade Class (24 Students)**

<b>Gender:</b>	Male	8	Female	16				
<b>Eye Color:</b>	Blue	6	Brown	4	Hazel	12	Green	2
<b>Hair Color:</b>	Blond	5	Red	1	Brown	15	Black	3

- male students to female students **8 to 16, 8:16,  $\frac{8}{16}$  (or  $\frac{1}{2}$ )**
- female students to male students **16 to 8, 16:8,  $\frac{16}{8}$  (or  $\frac{2}{1}$ )**
- red-haired students to all students **1 to 24, 1:24,  $\frac{1}{24}$**
- all students to green-eyed students **24 to 2, 24:2,  $\frac{24}{2}$  (or  $\frac{12}{1}$ )**

- Reasonableness** Is it reasonable to state that the ratio of male students to female students is the same as the ratio of male students to all students? Explain.

**No; the number of students that the male students are being compared to is different.**

- George has 2 sons and 1 daughter. What is the ratio of daughters to sons?

A 2 to 1

**B** 1 to 2

C 3:1

D  $\frac{2}{1}$

- Explain It** The ratio of blue beads to white beads in a necklace is 3:8. Nancy says that for every 11 beads, 3 are blue. Do you agree? Explain.

**Yes; Sample answer: If there are 3 blue beads to 8 white beads, that is 11 total beads, so 3 are blue.**



# Understanding Percent

Write the fraction in lowest terms and the percent that represents the shaded part of each figure.

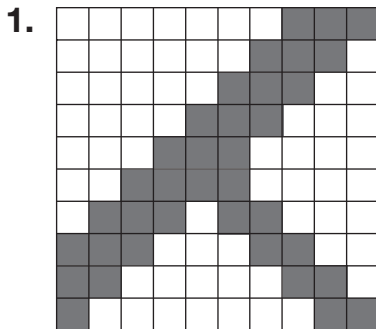

$$\frac{9}{25}, 36\%$$

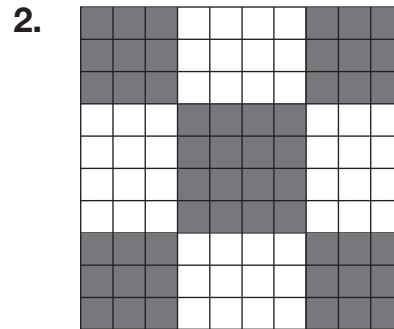

$$\frac{13}{25}, 52\%$$

3. **Strategy Practice** In the square, if part A is  $\frac{1}{4}$  of the square and part C is  $\frac{1}{10}$  of the square, what percent of the square is part B?

$$65\%$$

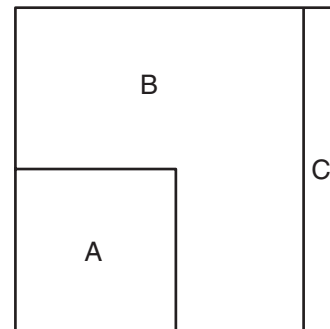

4. In Russia,  $\frac{1}{4}$  of the land is covered by forests. What percent of Russia is covered by forest? What percent of Russia is not covered by forest?

$$25\%; 75\%$$

5. In the United States,  $\frac{3}{10}$  of the land is forests and woodland. What percent of the United States is forest and woodland?

$$30\%$$

6. If  $\frac{2}{5}$  of a figure is shaded, what percent is not shaded?

A 20%

B 30%

C 50%

**D** 60%

7. **Explain It** Explain how a decimal is related to a percent.

**A percent is a decimal with the decimal point moved two places to the right.**

# Percents, Fractions, and Decimals

For questions 1 through 3, write the percent, decimal, and fraction in simplest form represented by the shaded part of each 100-grid.

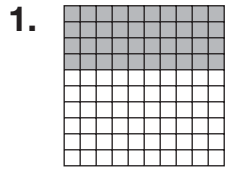

$$\underline{40\%, 0.4, \frac{2}{5}}$$

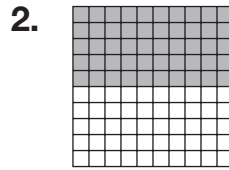

$$\underline{50\%, 0.5, \frac{1}{2}}$$

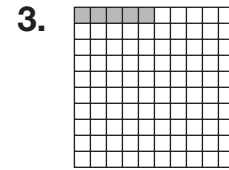

$$\underline{5\%, 0.05, \frac{1}{20}}$$

For questions 4 through 9, write each percent as a decimal and a fraction in simplest form.

4. 30%  $\underline{0.3, \frac{3}{10}}$

5. 60%  $\underline{0.6, \frac{3}{5}}$

6. 32%  $\underline{0.32, \frac{8}{25}}$

7. 11%  $\underline{0.11, \frac{11}{100}}$

8. 150%  $\underline{1.5, 1\frac{1}{2}}$

9. 100%  $\underline{1.0, 1}$

10. **Reasoning** If 40% of Jeanne's friends play kickball on weekends, what fraction of her friends don't play kickball?

$$\underline{\frac{3}{5}}$$

11. If there are 6 eggs in 50% of an egg crate, how many eggs are in the whole crate?

**12 eggs**

12. What would you do first to order the following numbers from least to greatest?

$$30\%, \frac{2}{3}, 0.67, \frac{8}{9}, 0.7$$

**A** Order the decimals.

**B** Convert the decimals to percents.

**C** Order the fractions.

**D** Convert all numbers to decimals.

13. **Explain It** When writing a percent as a decimal, why do you move the decimal point 2 places?

**Percent means "per hundred." Each decimal place is a factor of 10; 100 is two factors of 10.**

# Finding Percent of a Whole Number

Find each using mental math.

1. 20% of 60 12                      2. 30% of 500 150  
 3. 25% of 88 22                      4. 70% of 30 21

5. **Reasoning** Order these numbers from least to greatest.

0.85,  $\frac{1}{4}$ , 72%,  $\frac{5}{8}$ , 20%, 0.3

20%,  $\frac{1}{4}$ , 0.3,  $\frac{5}{8}$ , 72%, 0.85

6. What is 40% of 240?

A 48

**B** 96

C 128

D 960

The table below shows the percent of the population that live in rural and urban areas of each country. Use the table to answer 7 through 9.

	Rural	Urban
Bermuda	0%	100%
Cuba	25%	75%
Guatemala	60%	40%

7. Out of every 300 people in Cuba, how many of them live in a rural area? 75
8. Out of every 1,000 people in Guatemala, how many live in urban areas? 400
9. **Explain It** If there are 1,241,356 people who live in Bermuda, how many residents of Bermuda live in urban areas? How many live in rural areas? Explain your answer.

1,241,356 in urban; 0 in rural; Sample answer: If 100% are in urban areas, then 0% are in rural areas.

# Problem Solving: Make a Table and Look for a Pattern

For exercises 1 through 4, find each percent by completing each table.

1. 12 out of 40 days were rainy. **30%**

Rainy days	12	<b>6</b>	<b>3</b>	<b>30</b>
Total days	40	20	10	<b>100</b>

2. 2 out of 8 marbles are blue. **25%**

Blue	2	<b>4</b>	<b>1</b>	<b>25</b>
Total marbles	8	16	4	<b>100</b>

3. 32 out of 40 days were windy. **80%**

Windy days	32	<b>4</b>	<b>16</b>	<b>80</b>
Total days	40	5	20	<b>100</b>

4. 16 out of 40 pets on Jack's street are dogs. **40%**

Dogs	16	<b>32</b>	<b>4</b>	<b>40</b>
Total pets	40	80	10	<b>100</b>

5. **Write a Problem** Write a real-world problem that you can solve using a table to find a percent.

**Sample answer: Coins as a percent of a dollar or chance of rain**

6. Emmy plans to hike 32 miles this weekend. On Saturday, she hiked 24 miles. What percent of her goal has Emmy hiked?

**75%**

7. **Explain It** Dave estimated 45% of 87 by finding 50% of 90. Will his estimate be greater than or less than the exact answer?

**Greater than: since  $50\% > 45\%$  and  $90 > 87$ , his estimate will be greater than the exact answer.**

# Understanding Integers

Write an integer for each word description.

1. a withdrawal of \$50    2. a temperature rise of  $14^\circ$     3.  $10^\circ$  below zero
- 50                              +14                              -10

Use the number line for 4 through 7. Write the integer for each point.

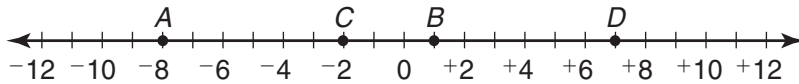

4. A     -8        5. B     +1        6. C     -2        7. D     +7

Compare. Use  $>$ ,  $<$ , or  $=$  for each  $\bigcirc$ .

8.  $-5$   $\bigcirc$   $>$   $-9$                       9.  $+8$   $\bigcirc$   $>$   $-12$                       10.  $+21$   $\bigcirc$   $>$   $-26$

Write in order from least to greatest.

11.  $-4, +11, -11, +4$                           -11    ,     -4    ,     +4    ,     +11
12.  $-6, +6, 0, -14$                           -14    ,     -6    ,     0    ,     +6
13.  $+11, -8, +7, -4$                           -8    ,     -4    ,     +7    ,     +11

14. **Strategy Practice** Which point is farthest to the right on a number line?

A  $-6$                       B  $-2$                       C  $0$                       **D**  $2$

15. **Explain It** In Fenland, U.K., the elevation from sea level is  $-4m$ . In San Diego, U.S., it is  $+40$  ft. The elevations are given in different units. Explain how to tell which location has a greater elevation.

**San Diego: any positive elevation is greater than a negative one.**

---



---

# Ordered Pairs

Write the ordered pair for each point.

1. A **(3, 4)**

2. B **(-2, 3)**

3. C **(2, -3)**

4. D **(-5, -4)**

5. E **(-7, 1)**

6. F **(8, 6)**

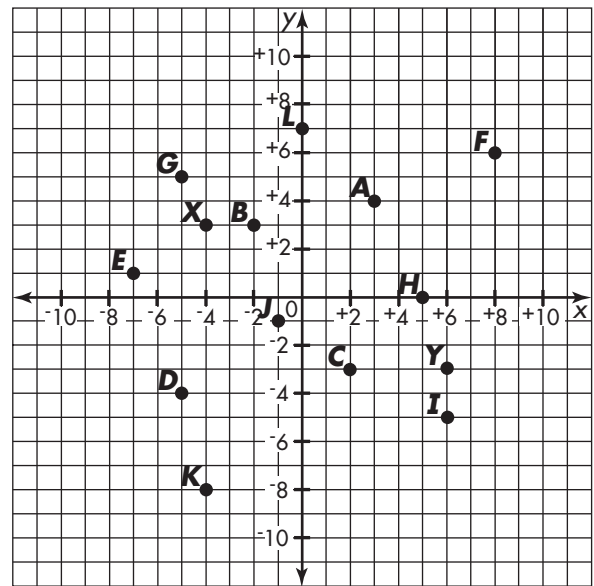

Name the point for each ordered pair.

7.  $(+5, 0)$  **H**

8.  $(-1, -1)$  **J**

9.  $(0, +7)$  **L**

10.  $(+6, -5)$  **I**

11.  $(-4, -8)$  **K**

12.  $(-5, +5)$  **G**

13. **Strategy Practice** If a taxicab were to start at the point  $(0, 0)$  and drive 6 units left, 3 units down, 1 unit right, and 9 units up, what ordered pair would name the point the cab would finish at?

**(-5, 6)**

14. Use the coordinate graph above. Which is the y-coordinate for point X?

A +6   **(B) +3**   C 3   D 6

15. **Explain It** Explain how to graph the ordered pair  $(-2, +3)$ .

**Begin at the origin and move****2 places to the left for the x-value****of -2. Then move 3 spaces up for****the y-value of 3.**

# Distances on Number Lines and the Coordinate Plane

Find the distance between each pair of integers on a number line.

1.  $-7, -3$   
4 units

2.  $-7, 1$   
8 units

3.  $-4, 0$   
4 units

4.  $0, 5$   
5 units

5.  $2, 8$   
6 units

6.  $-3, 3$   
6 units

Find the distance between the points named by each set of ordered pairs on the coordinate plane.

7.  $(-2, 5), (-2, -1)$  6 units

8.  $(-4, 1), (0, 1)$  4 units

9.  $(-1, 7), (-1, -2)$  9 units

10.  $(-2, -6), (-1, -6)$  1 unit

11. At 2:00 P.M., the temperature was  $3^{\circ}\text{C}$ . By 4:00 P.M., the temperature had dropped to  $-1^{\circ}\text{C}$ . What was the amount of the decrease in temperature?

$4^{\circ}\text{C}$

12. **Strategy Practice** What integer on a number line is the same distance from 0 as  $+4$ ?

$-4$

13. On the coordinate plane, what is the distance between the points named by  $(+2, -6)$  and  $(-3, -4)$ , if you move only along the lines of the grid?

A 11

B 9

**C** 7

D  $-7$

14. **Explain It** How can you tell if two points lie along the same grid line just by looking at the ordered pairs?

If two points lie along the same grid line, then the ordered pairs that name the points either have the same x-value or the same y-value.

# Graphing Equations

In 1 through 4, find the value of  $y$  when  $x = 4, 9,$  and  $15$ .

1.  $y = 2x$  8, 18, 30                      2.  $y = x - 4$  0, 5, 11

3.  $y = 4x$  16, 36, 60                      4.  $y = x + 6$  10, 15, 21

In 5 through 8, make a table of values for each equation and then graph the equations. Let  $x = 1, 3, 5,$  and  $7$ .

5.  $y = x + 2$  3, 5, 7, 9                      6.  $y = 3x$  3, 9, 15, 21

7.  $y = x - 1$  0, 2, 4, 6                      8.  $y = x + 5$  6, 8, 10, 12

9. **Reasoning** Without drawing the graph, describe what the graph of  $x = 100$  would look like. Explain.

It would be a vertical line at 100;  
every point on that line would have an  
 $x$ -coordinate of 100.

10. **Reasonableness** Which of the following ordered pairs is **NOT** on the graph of the equation  $y = x + 9$ ?

A (7, 16)                      B (15, 24)                      C (20, 29)                      **D** (28, 36)

11. **Explain It** A graph contains the ordered pair (2, 4). Write two different equations that would be possible for this graph. Explain how you found your answer.

$y = 2x$  or  $y = x + 2$  are both possible  
answers because their solutions both  
include the ordered pair listed.



# Problem Solving: Work Backward

Solve each problem by working backward. Write the answers in complete sentences.

Barbara is refilling her bird feeders and squirrel feeders in her yard.

1. After filling her bird feeders, Barbara has  $3\frac{1}{2}$  c of mixed birdseed left. The two feeders in the front yard took  $4\frac{1}{2}$  c each. The two feeders in the backyard each took  $2\frac{3}{4}$  c. The two feeders next to the living room window each took  $3\frac{1}{4}$  c. How much mixed birdseed did Barbara have before filling the feeders?

$$24\frac{1}{2} \text{ c}$$

---

2. After Barbara fills each of her 4 squirrel feeders with  $2\frac{2}{3}$  c of peanuts, she has  $1\frac{3}{4}$  c of peanuts left. How many cups of peanuts did Barbara start with?

$$12\frac{5}{12} \text{ c}$$

---

3. **Strategy Practice** Clint spends  $\frac{1}{4}$  hour practicing trumpet,  $\frac{1}{2}$  hour doing tasks around the house,  $1\frac{1}{2}$  hour doing homework, and  $\frac{3}{4}$  hour cleaning his room. He is finished at 7:30 P.M. When did Clint start?

A 4:00 P.M.

B 4:15 P.M.

C 4:30 P.M.

D 5:30 P.M.

4. **Write a Problem** Write a real-world problem that you can solve by working backward.

**Answers will vary. See students' work.**

---



---

# Data from Surveys

Ms. Chen’s class took a survey on how many minutes it took each student to get to school. The results are below:

12 14 5 22 18 12 12 6 14 18 12 5 11

1. What are the highest and lowest times?

**22 and 5**

2. Make a line plot to display the data.

**Students in Ms. Chen’s Class**



**Music Bought in Class B**

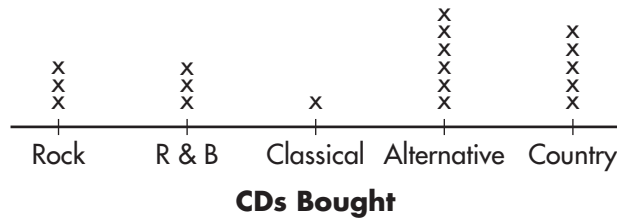

3. If the entire class responded to the survey, how many students are in the class?

**18 students**

4. What information was collected about music?  
**The type of music CDs students buy most often**

5. Use the line plot above. Which type of CDs did students buy most often?

- A** Alternative      **B** Classical      **C** Country      **D** Rock

6. **Explain It** Write a survey question that might gather the following information. “In one school there are 6 sets of twins, 2 sets of triplets, and one set of quadruplets.”

**Sample answer: Are you one of a set of twins, triplets, or quadruplets?**

# Bar Graphs and Picture Graphs

In 1 and 2, answer the questions about the double-bar graph below.

1. How many boys play indoor soccer? How many girls play?

**12 boys and 14 girls**

2. What is the least popular sport among girls? Among boys?

**Track**

**is least popular among girls and swimming among the boys.**

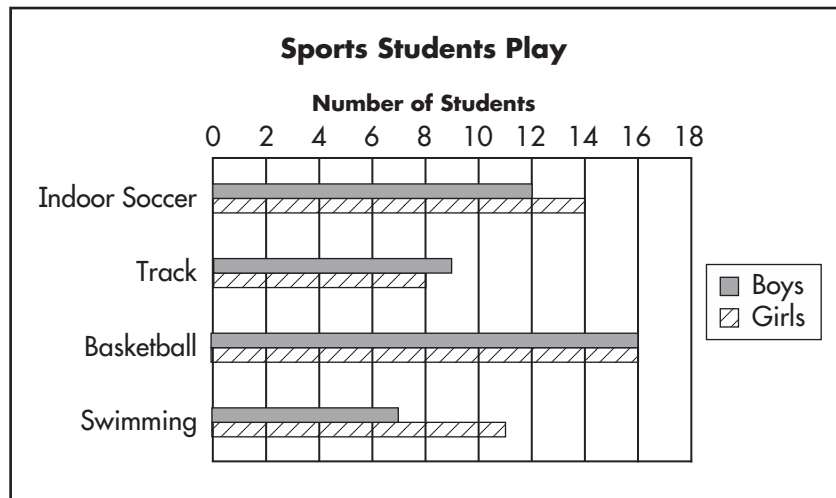

3. Frank bought 4 dozen doughnuts for his class. He had 4 left over. Which shows how to find how many doughnuts Frank gave away?

A  $(48 \times 2) - 4$       C  $(12 \times 2) + 4$   
 B  $(24 \times 2) - 12$       **D**  $(12 \times 4) - 4$

4. **Explain It** Could the data in the bar graph in Exercise 1 be presented in a picture graph? Explain.

**Yes, each game could be represented by a symbol like a basketball, water, etc. and a human figure could represent each participating student. The figures would be differently colored for boys or girls.**

# Line Graphs

Display the data in the table below on the coordinate grid.

Hour	Temperature (Celsius)
1	4°
2	8°
3	16°
4	21°

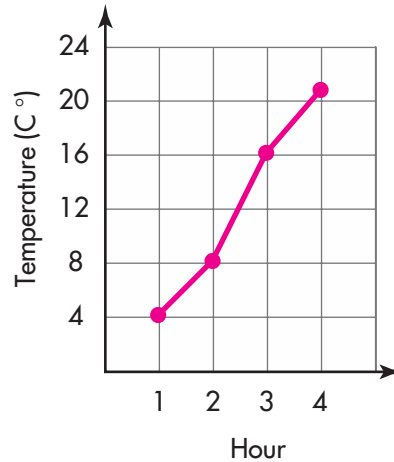

1. Which hour had the highest temperature? \_\_\_\_\_

**Hour 4**

2. How much higher was the temperature in Hour 4 than Hour 1? \_\_\_\_\_

**17 degrees**

3. **Reasoning** If Hour 1 was really 10:00 P.M., do you think the trend on the line graph would keep increasing? Explain.

**No, because in the evening, the temperature should drop.**

4. **Critical Thinking** Look at the line graph at the right. What do you know about the trend of the housing prices?

- A Housing prices increased.  
 B Housing prices decreased.  
 C Housing prices increased, then decreased.  
 D Housing prices decreased, then increased.

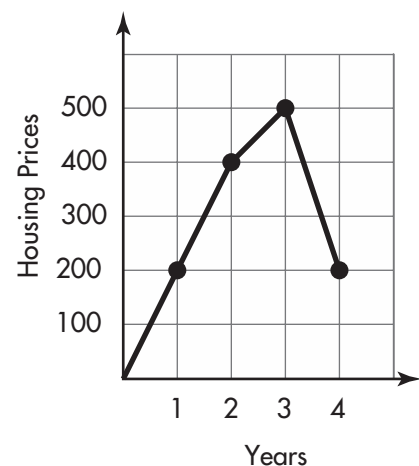

5. **Explain It** In the example above, if housing prices had stayed the same for all four years, what would the line graph look like? Explain.

**A straight horizontal line; it indicates no change occurred.**

# Stem-and-Leaf Plots

For **1** through **3**, use the stem-and-leaf plot below. It shows the ages of the 17 people who used the outdoor pool from 6:00 A.M. to 7:00 A.M. on a Tuesday morning in the summer.

Ages (years)	
Stem	Leaf
0	
1	1
2	3 9
3	
4	7
5	5 7 7 9
6	5 5 6 6 7 8 9
7	0 1

1. How many swimmers were younger than 30?

**3**

2. Which age group was swimming the most at this hour?

**people in their sixties or retirees**

3. Why are there two 5's as leaves next to the stem 6?

**the age 65 appears in the table twice**

4. Make a stem-and-leaf plot of the data below.

Prices of couch pillows (dollars)			
10	75	20	20
37	24	21	9

Stem	Leaf
0	9
1	0
2	0 0 1 4
3	7
7	5

**Key: 7 | 5 means 75**

5. Refer to the stem-and-leaf plot in Exercise 4. Which stem (or stems) have the most leaves?

**A** 70      **B** 9      **C** 20      **D** 30

# Histograms

This table shows the results of a class survey to find out how many pieces of fruit each student ate that week.

Amount of Fruit	Frequency
0–7	12
8–15	8
16–25	5

- Complete the histogram below. What percentage of students ate 16–25 pieces of fruit that week?

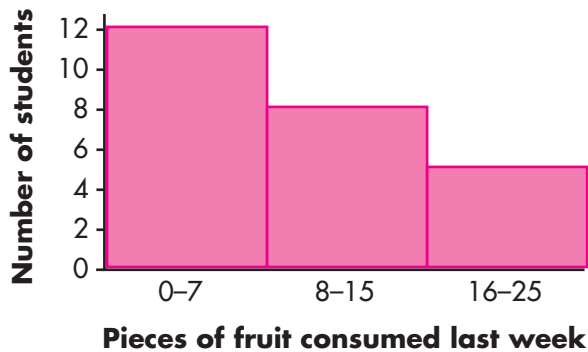

**5 out of 25 total students = 20%**

- Reasoning** Mary says a histogram shows that about 3 times as many people in the 60–79 age group answered a survey as in the 80–99 age group. How does she know this from looking at the histogram?

**The bar that represents ages 60–79 is three times as tall as the bar that represents ages 80–99.**

- Explain It** A political campaign recorded the ages of 100 callers. In a histogram, which data would go on the horizontal axis and which on the vertical?

**The horizontal axis would show equal age intervals. The vertical axis would show the numbers of callers in each age bracket.**

# Circle Graphs

1. A bagel shop offers a variety of bagels. One morning, the following choices were made by the first 20 customers of the day: plain, 10; poppy seed, 5; sesame seed, 3; multigrain, 2. Complete the table below.

	Fraction	Percent
Plain	$\frac{1}{2}$	<b>.50</b>
Poppy Seed	$\frac{1}{4}$	<b>.25</b>
Sesame Seed	$\frac{3}{20}$	<b>.15</b>
Multigrain	$\frac{1}{10}$	<b>.10</b>

2. Copy and complete the circle graph below with the data in the table above. Label each section with the percent and fraction of each bagel.

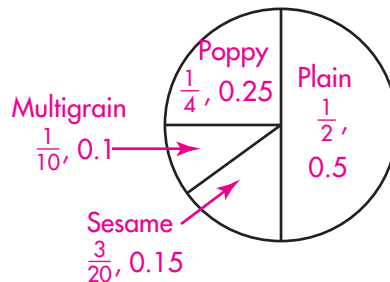

3. **Number Sense** A circle graph is divided into four sections. One section equals 40%. The other three sections are equal in size. What percent does each of the other three sections represent?

**20%**

4. **Reasoning** If 10 out of 30 students in a survey chose ice skating as their favorite sport, what fraction of the circle should be shaded to represent the students who chose ice skating? How many degrees will that segment of the circle include?

**$\frac{1}{3}$ ;  $120^\circ$**

# Mean

Find the mean of each set of data.

- |                             |       |            |
|-----------------------------|-------|------------|
| 1. 2, 5, 9, 4               | _____ | <b>5</b>   |
| 2. 44, 73, 63               | _____ | <b>60</b>  |
| 3. 11, 38, 65, 4, 67        | _____ | <b>37</b>  |
| 4. 3, 6, 3, 7, 8            | _____ | <b>5.4</b> |
| 5. 120, 450, 630            | _____ | <b>400</b> |
| 6. 4.2, 5.3, 7.1, 4.0, 11.9 | _____ | <b>6.5</b> |

Gene's bowling scores were as follows: 8, 4, 10, 10, 9, 6, 9.

7. What was his average bowling score? \_\_\_\_\_ **8**
8. If Gene gets two more strikes (scores of 10), what is his new average? \_\_\_\_\_ **8.44**
9. **Reasoning** Krishan wants his quiz average to be at least 90 so that he can get an A in the class. His current quiz scores are: 80, 100, 85. What does he have to get on his next quiz to have an average of 90?
- A** 85                      **B** 90                      **C** 92                      **D** 95
10. **Explain It** Suppose Krishan's teacher says that he can drop one of his test scores. Using his test scores of 80, 100, and 85, which one should he drop, and why? What is his new average?

**Drop the lowest score: 80. His new average would be 92.5.**

---



# Median, Mode, and Range

- Find the range of this data set: 225 342 288 552 263. 327
- Find the median of this data set: 476 234 355 765 470. 470
- Find the mode of this data set:  
16 7 8 5 16 7 8 4 7 8 16 7. 7
- Find the range of this data set:  
64 76 46 88 88 43 99 50 55. 56
- Reasoning** Would the mode change if a 76 were added to the data in Exercise 4?

**Yes. The mode is now 88. With another 76, the modes would be 76 and 88.**

The table below gives the math test scores for Mrs. Jung's fifth-grade class.

76	54	92	88	76	88
75	93	92	68	88	76
76	88	80	70	88	72
<b>Test Scores</b>					

- Find the mean of the data. 80
- Find the mode of the data. 88
- Find the median of the data. 78
- What is the range of the data set? 39
- Find the range of this data set: 247, 366, 785, 998.  
 A 998      B 781      **C 751**      D 538
- Explain It** Will a set of data always have a mode?  
Explain your answer.

**No: if every item is different, there is no mode.**

# Problem Solving: Make a Graph

1. In a survey, 100 students from around the country were asked what news source they preferred. Which news source is most popular? Make a circle graph to solve the problem.

News Source	Number of Votes
Television	48
Internet	27
Newspaper	15
Radio	10

**Students' Preferred News Source**

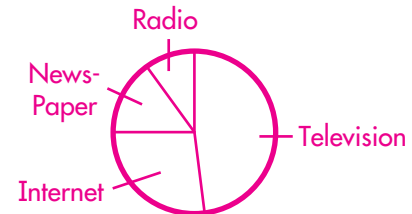

2. In a survey, 30 students from around the country were asked how they traveled to and from school. Make a circle graph to show the data.

Subway	Bus	Bike	On Foot	Taxi
6	12	4	8	0

**How Students Get to School**

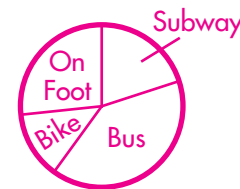

3. If a graph shows that there were 10 people who watched between 7 and 12 movies, what kind of graph could you be looking at?

**A** Circle      **B** Bar      **C** Histogram      **D** Line

4. **Explain It** Would a line graph be an appropriate graph in Exercise 3? Why or why not?

**Sample answer: No; a line graph is used to show data that changes over time. These data do not change over time.**

# Translations

Give the vertical and horizontal translation in units.

1.

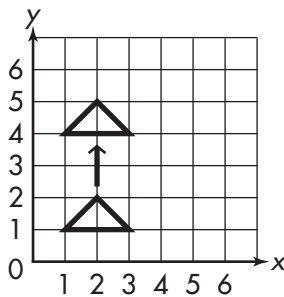

**up 3 units**

2.

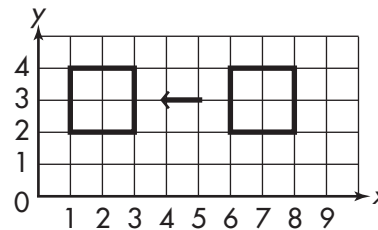

**left 5 units**

3.

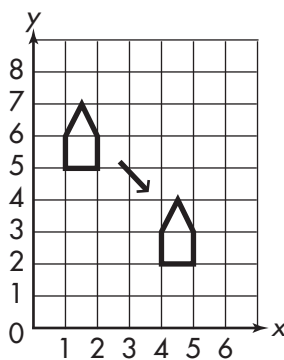

**right 3 units,  
down 3 units**

4.

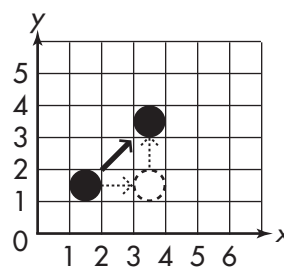

**right 2 units,  
up 2 units**

5. **Critical Thinking** If a vertex of a square moved from  $(11, 9)$  to  $(6, 4)$ , which of the following describes the translation?

**A** 5 left, 5 up

**C** 5 right, 5 up

**B** 5 left, 5 down

**D** 5 right, 5 down

6. **Explain It** Explain how the  $x$  and  $y$  coordinates are related to the direction an object moves.

**The  $x$ -coordinate increases when the object moves right and decreases when it moves left. The  $y$ -coordinate increases when an object moves up and decreases when it moves down.**

# Reflections

Draw the reflection of the object across the reflection line.

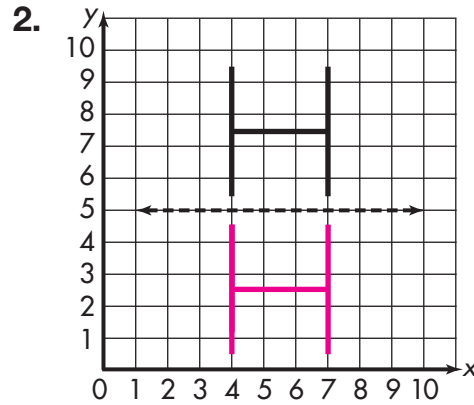
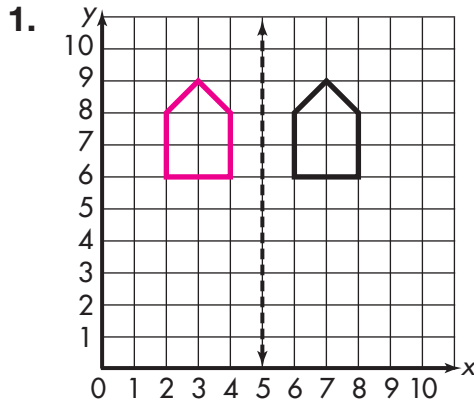

Tell whether the figures in each pair are related by a translation or a reflection.



**Reflection**

**Reflection or translation**

5. **Think About the Process** Which of the following gives enough information to determine whether the figures A and B have been translated or reflected?

- A Figure A is larger than Figure B.
- B Figure A and Figure B have the same shape and size.
- C Figure A has an identical shape to Figure B.
- D Figure A and Figure B are next to each other.

# Rotations

Describe whether the figures in each pair are related by a rotation, a translation, or a reflection.



**rotation**



**translation or reflection**

3. If the figure at the right is rotated  $90^\circ$  around the point shown, which of the figures below could be the result?

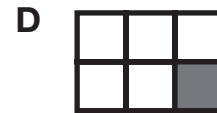
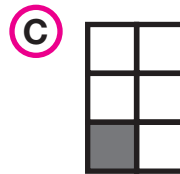
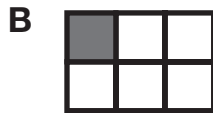
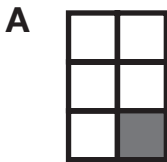

4. **Explain It** Mark says that the figure at the right is a reflection. Faith says that it is a rotation. Who is correct? Explain.

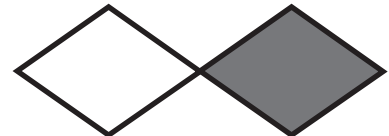

**They are both correct. It could be a reflection over a vertical line or it could be a  $180^\circ$  rotation.**

---



---



---

# Congruence

Tell whether the following figures are congruent or not.

1.

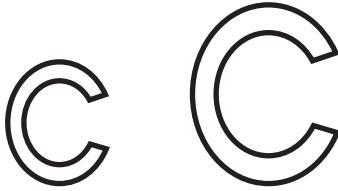
**No**

2.

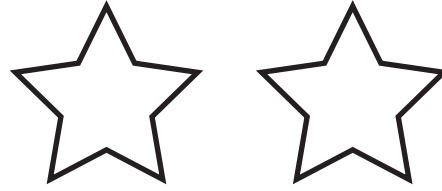
**Yes**

Identify each transformation. If not a transformation, explain why.

3.

**Not; figures are not the same size or shape**

4.

**Rotation**

5. **Reasonableness** Which of the following situations uses an example of congruent figures?

A A baker uses two sizes of loaf pans.

B The fifth-grade math book is wider than the fourth-grade book.

**C** You give five friends each a quarter.

D Two pencils are sharpened, the other two are not.

6. **Explain It** If two triangles are congruent, do they both have the same side lengths? Explain.

**Yes, if the triangles are congruent, they are exactly the same size, and all side lengths are equal.**

# Symmetry

For 1 through 4, tell if the figure has line symmetry, rotational symmetry, or both. If it has line symmetry, how many lines of symmetry are there? If it has rotational symmetry, what is the smallest rotation that will rotate the figure onto itself?



**1 line of symmetry**

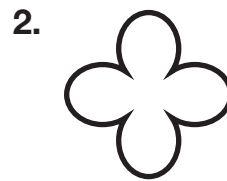

**4 lines of symmetry;**

**90° or  $\frac{1}{4}$  turn**



**180° or  $\frac{1}{2}$  turn**

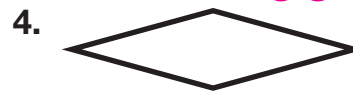

**2 lines of symmetry;**

**180° or  $\frac{1}{2}$  turn**

For 5 and 6, copy the figure. Then complete the figure so the dashed line is a line of symmetry.

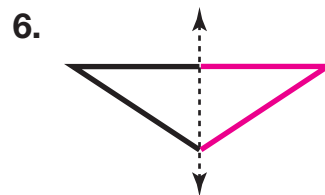
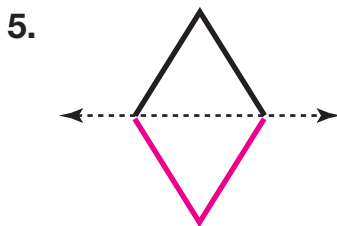

7. Does any rectangle rotate onto itself in less than a half-turn?

**A rectangle that is a square rotates onto itself in a 90° or quarter turn.**

8. **Draw a Picture** Draw a quadrilateral that has neither line symmetry nor rotational symmetry.

**Answers will vary.**

# Problem Solving: Use Objects

1. Is the following a pentomino? Explain.



**Yes; there are 5  
identical squares.**

Tell whether the pentominoes in each pair are related by a reflection or a rotation.

2.

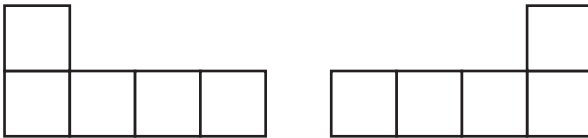

**Reflection**

3.

**Rotation**

4. How many possible different pentominoes can be formed?

**A** 3

**B** 7

**C** 10

**D** 12

5. **Explain It** Use objects to build pentominoes with 1 square in each row. How many of these kinds of pentominoes can be built? Explain.

**Only 1; using 5 squares, you can only  
put one square in each row, and every  
pentomino after that will be the same!**



# Outcomes

The coach is trying to decide in what order Jane, Pete, and Lou will run a relay race.

1. Complete the tree diagram below to show the sample space.

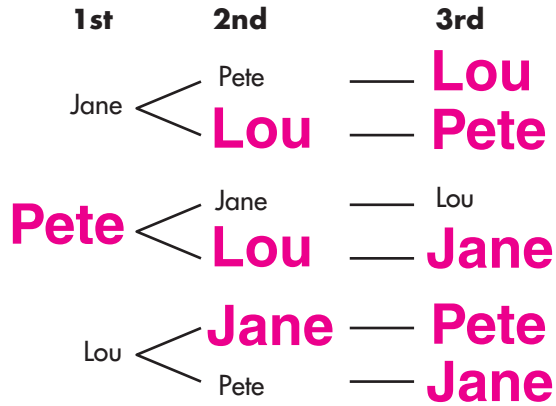

2. How many possible outcomes are there in the sample space? **6** \_\_\_\_\_
3. After the first runner is chosen, how many choices are there for the second runner? **2** \_\_\_\_\_
4. **Reasonableness** Tom, Bill, John, and Ed are running for school president. The person in second place automatically becomes vice-president. How many possible outcomes are there in the sample space?  
**A** 6                      **B** 9                      **C** 10                      **(D)** 12
5. **Explain It** The weather tomorrow could be sunny, cloudy, rainy, or snowy. Is there a 1 out of 4 chance of the weather being sunny?

**You do not know what the probability is, because not all the outcomes are equally likely.**

# Writing Probability as a Fraction

Tom put 4 yellow marbles, 2 blue marbles, 6 red marbles, and 5 black marbles in a bag.

1. Find  $P(\text{yellow})$ .

$$\frac{4}{17}$$

2. Find  $P(\text{blue})$ .

$$\frac{2}{17}$$

3. Find  $P(\text{black})$ .

$$\frac{5}{17}$$

4. Find  $P(\text{red})$ .

$$\frac{6}{17}$$

A bag contains 12 slips of paper of the same size. Each slip has one number on it, 1–12.

5. Find  $P(\text{even number})$ .

$$\frac{6}{12} \text{ or } \frac{1}{2}$$

6. Find  $P(\text{a number less than 6})$ .

$$\frac{5}{12}$$

7. Find  $P(\text{an odd number})$ .

$$\frac{6}{12} \text{ or } \frac{1}{2}$$

8. Find  $P(\text{a number greater than 8})$ .

$$\frac{4}{12} \text{ or } \frac{1}{3}$$

9. Describe an impossible event.

**You will pull out a number greater than 12.**

10. A cube has 6 sides and is numbered 1 through 6. If the cube is tossed, what is the probability that a 3 will be tossed?

**A**  $\frac{1}{6}$

**B**  $\frac{2}{6}$

**C**  $\frac{3}{6}$

**D**  $\frac{6}{6}$

11. **Explain It** Explain the probability of tossing a prime number when you toss the cube with numbers 1 through 6.

**Prime numbers would be 2, 3, and 5, so the probability would be  $\frac{3}{6}$  or  $\frac{1}{2}$ .**

# Experiments and Predictions

Write each of the following as a fraction in lowest terms.

1. 20 out of 60

$$\frac{1}{3}$$

2. 16 out of 64

$$\frac{1}{4}$$

3. 24 out of 60

$$\frac{2}{5}$$

The table below shows data from the woodshop classes at Jones Elementary School. Students had the choice of making a shelf, a chair, or a birdhouse.

Project	Number of students
Shelf	15
Chair	25
Birdhouse	20

4. What is the total number of students who were taking a woodshop class?

$$\frac{60}{5} = \frac{12}{1}$$

5. What is the probability that someone will make a chair? a birdhouse?

$$\frac{1}{3}$$

6. Predict how many students will make a shelf if there are 180 students in the woodshop class.

$$45$$

7. **Reasonableness** Using the letters in the word ELEMENTARY, find the probability of choosing a letter that is not E.

A  $\frac{3}{10}$

B  $\frac{5}{10}$

C  $\frac{7}{10}$

D  $\frac{9}{10}$

8. **Explain It** If  $\frac{2}{3}$  of the 45 customers in the past hour bought a cup of coffee, predict the number of cups that will be sold in the next 3 hours if sales continue at the same level.

$$90; \text{ if } 30 \text{ are sold in } 1 \text{ hour, } 30 \times 3 = 90$$

# Problem Solving: Solve a Simpler Problem

Solve the simpler problems. Use the solutions to help you solve the original problem.

1. Reggie is designing a triangular magazine rack with 5 shelves. The top shelf will hold 1 magazine. The second shelf will hold 3 magazines, and the third shelf will hold 5 magazines. This pattern continues to the bottom shelf. How many magazines will the magazine rack hold altogether?

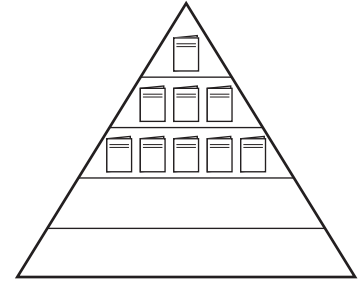

**Simpler Problem** What is the pattern?

**Each shelf down holds 2 more**

**magazines than the shelf above.**

How many magazines will the fourth shelf hold?

**7 magazines**

How many magazines will the bottom shelf hold?

**9 magazines**

**Solution:**

**The magazine rack will hold 25**

**magazines.**

2. At the deli, you receive 1 free sub after you buy 8 subs. How many free subs will you receive from the deli if you buy 24 subs?

**3 subs**

3. The chef has 5 different kinds of pasta and 3 different flavors of sauce. How many different meals is she able to make?

**15 different meals**