

Diagramming Worksheets Name: _____

Sentence Diagram - A sentence diagram is a chart that shows the relation of the words, phrases, and clauses in a sentence to analyze a fault in a sentence or whether the word "who" or "whom" is to be used.

Subject Noun And Predicate Verb



I sing.

You are singing.

He has been singing.

We have been singing.

You had been singing.

They had sung.

Diagramming Worksheets Name: _____

Compound Subject Simple Sentence

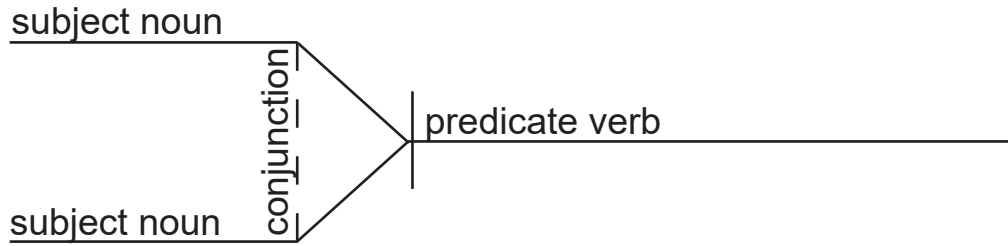

Joseph and Mary sing.

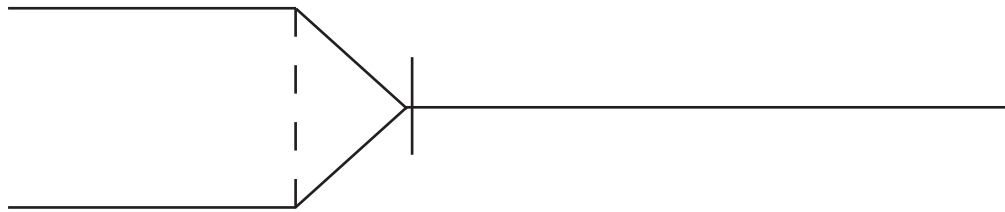

James and John wrote.

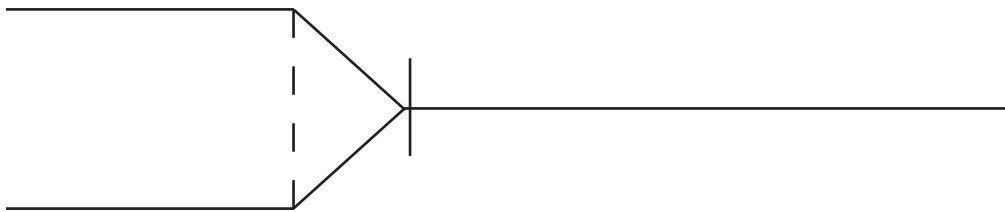

Matthew, Mark, Luke, and John evangelized.

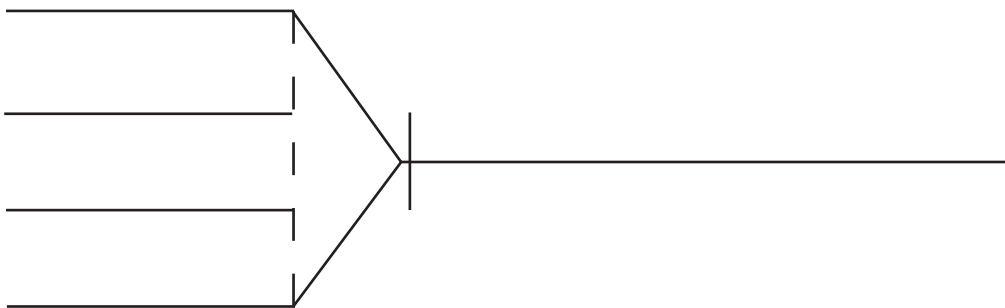

Diagramming Worksheets

Compound Predicate Simple Sentence

Name: _____

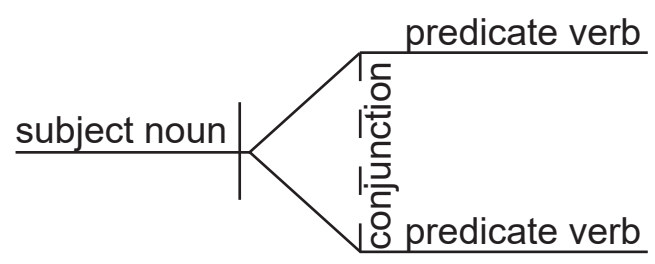

I worked and left.

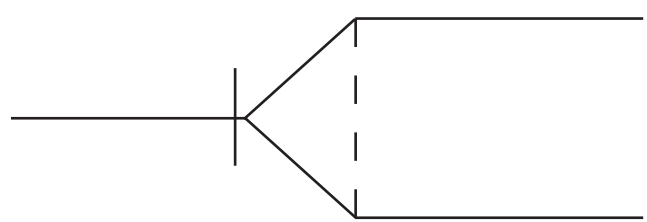

You have come and gone.

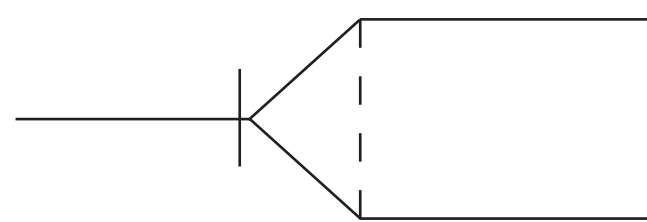

He will come or regret.

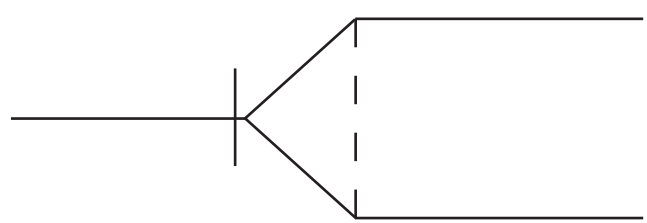

Date: _____

Diagramming Worksheets Name: _____

Dummy Subjects (Like direct address and exclamations)

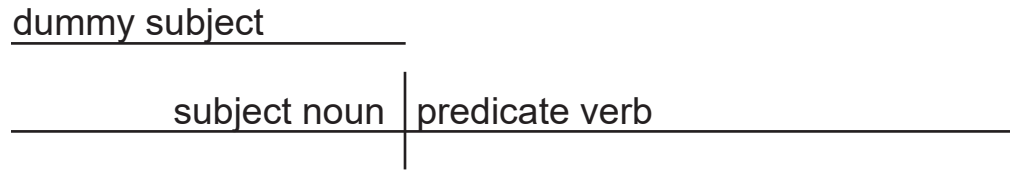

There flew a hawk.

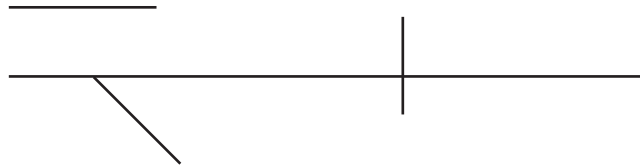

There arose a storm.



It is encouraging to be together.

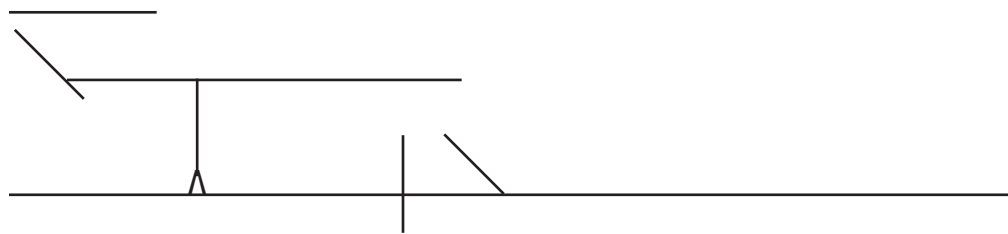

There grew a tree in the field.

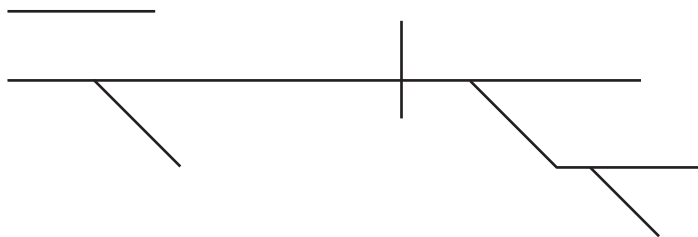

Diagramming Worksheets Name: _____

Direct Objects



John wrote testimonials.



Laura likes apples and bananas.

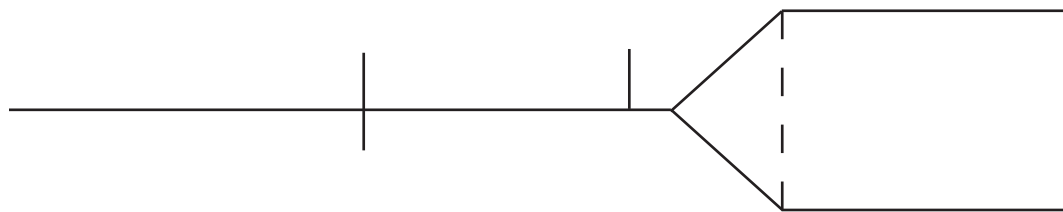

Paul wrote letters.

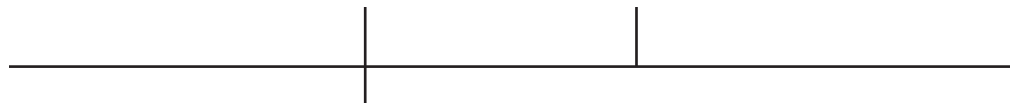

Joseph built tables.

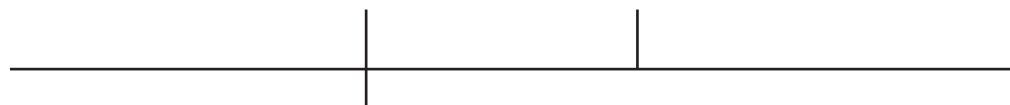

Diagramming Worksheets Name: _____

Indirect Objects

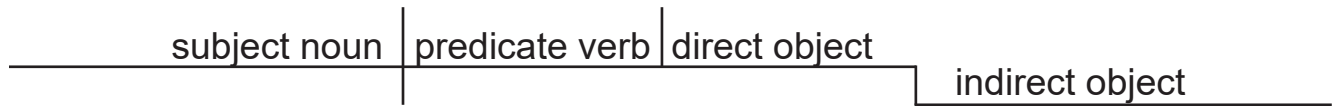

Dr. Brown brought Dad medicine.

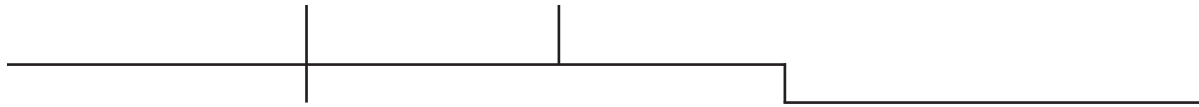

Sally sent my Mother flowers.

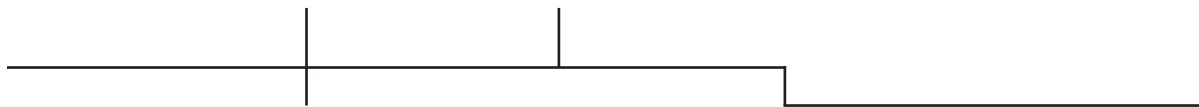

John took the coach equipment.

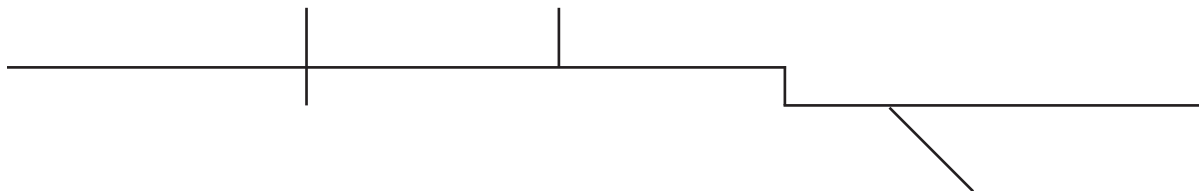

Andrew gave Michael and Anthony pictures.

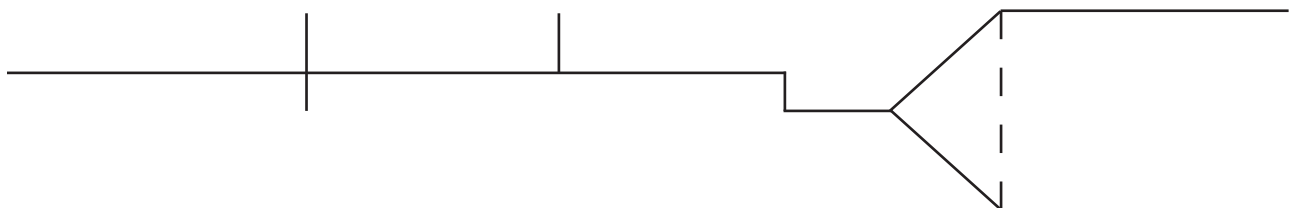

Diagramming Worksheets Name: _____

Predicate Complements

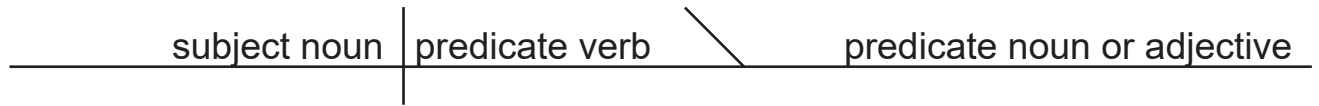

Predicate Noun Or Pronouns

This is milk.



Those are clouds.

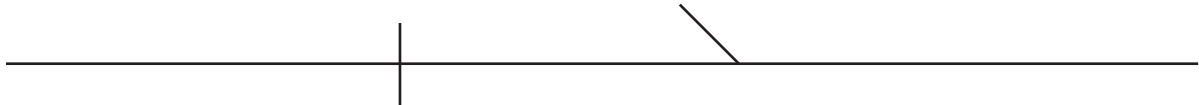

This is mud.



It is she.

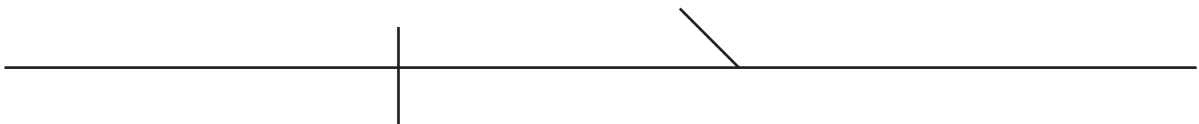

Predicate Adjectives

This is milky.

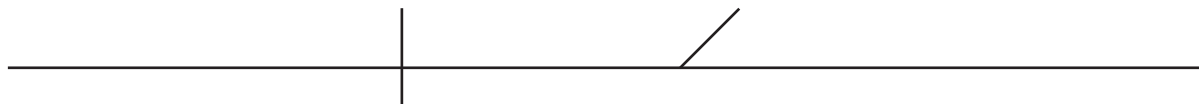

That is cloudy.

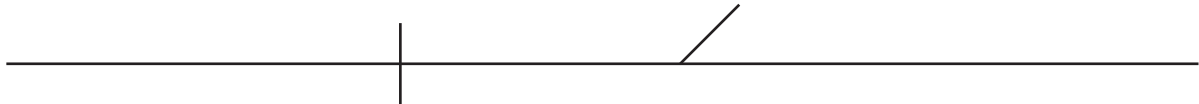

This is muddy.

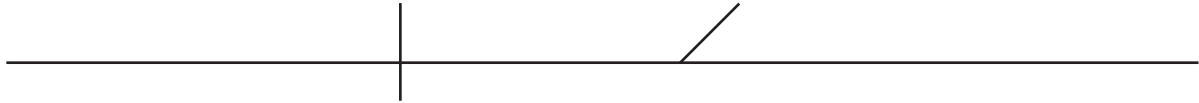

It is hers.



Diagramming Worksheets Name: _____

Objective Complement

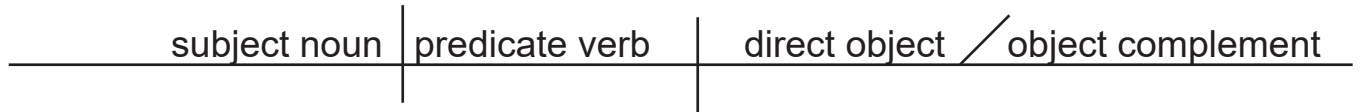

The class elected Shannon president. (noun)

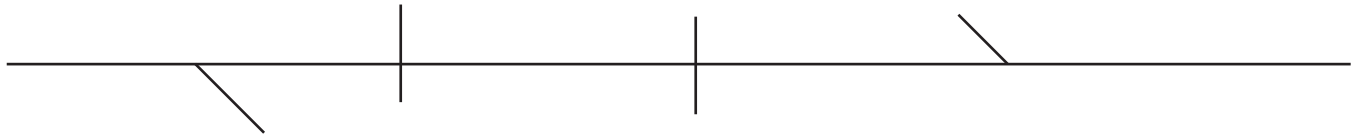

Missouri voted him governor. (noun)



Nancy chose Susan first. (adjective)

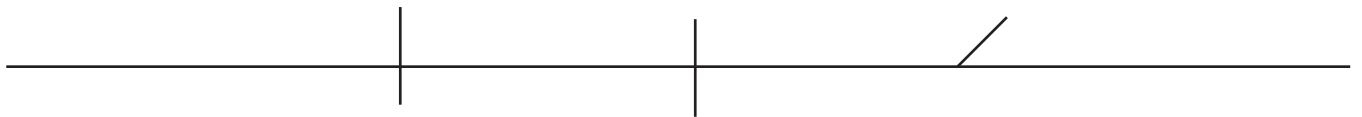

She called it beautiful. (adjective)

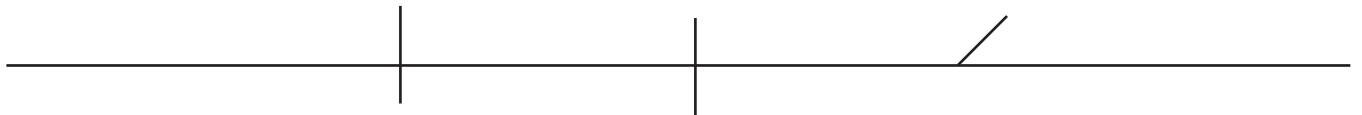

She was appointed secretary and treasurer. (compound noun)

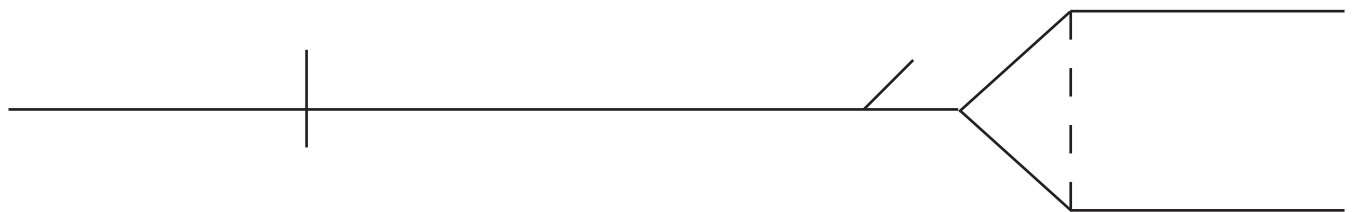

Black Jack was groomed neat and clean. (compound adjective)



Diagramming Worksheets Name: _____

Adjectives

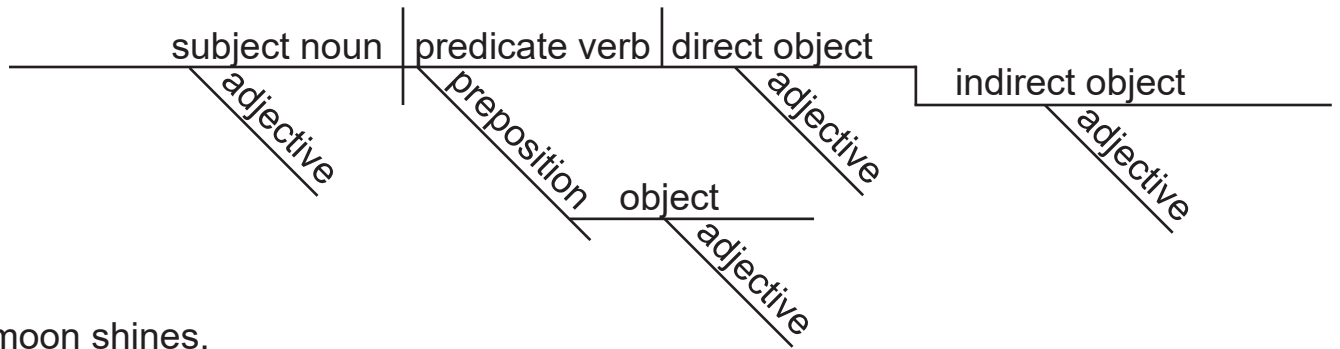

The moon shines.

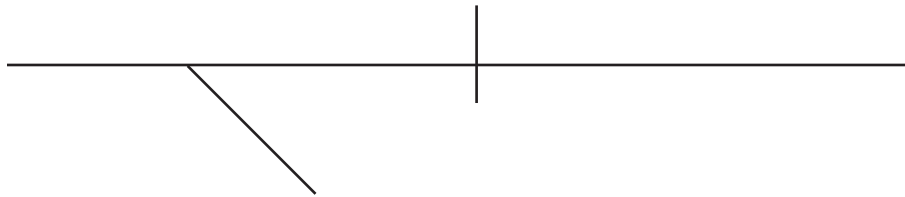

The evening moon and the daytime sun shine.

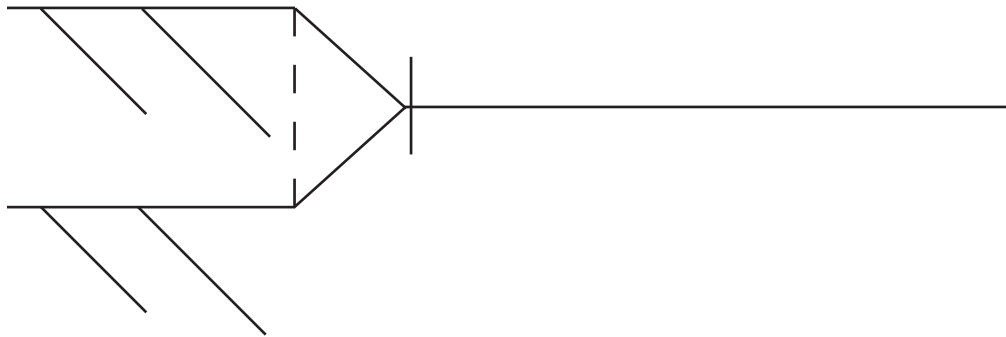

Bright and happy, the painter finished the bookshelf.

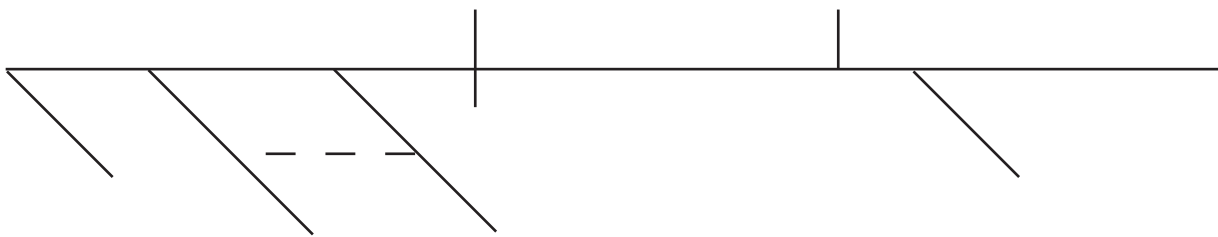

During the afternoon recital the conductor showed only us the new score.

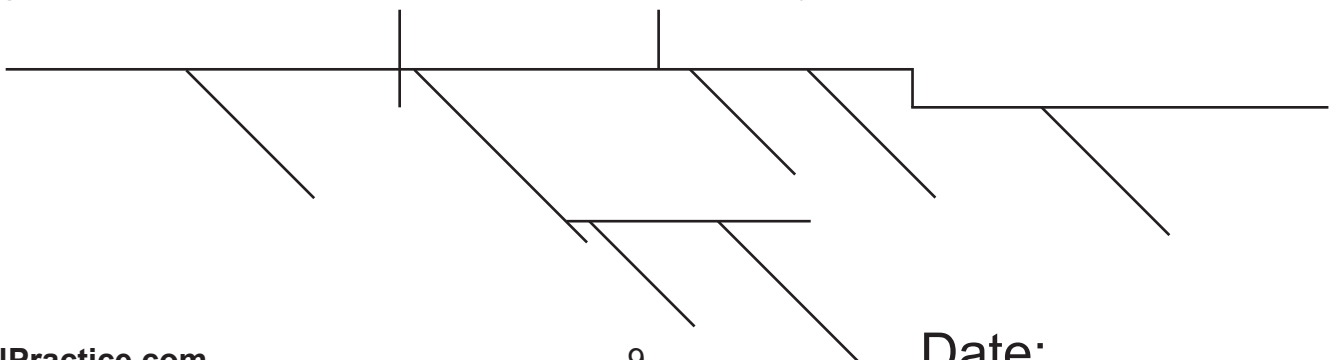

Diagramming Worksheets Name: _____

Adverb

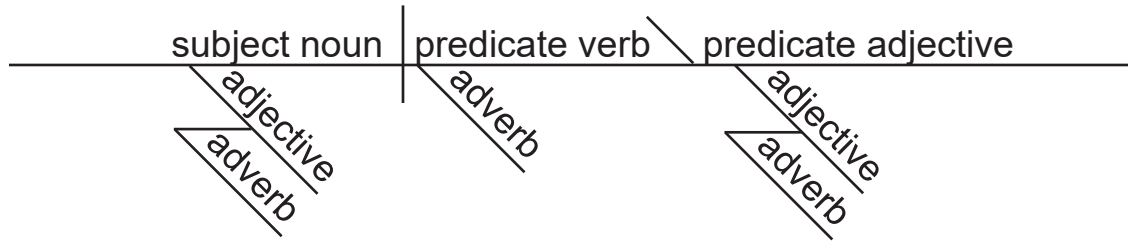

Very expensive tools are frequently nearly all available.

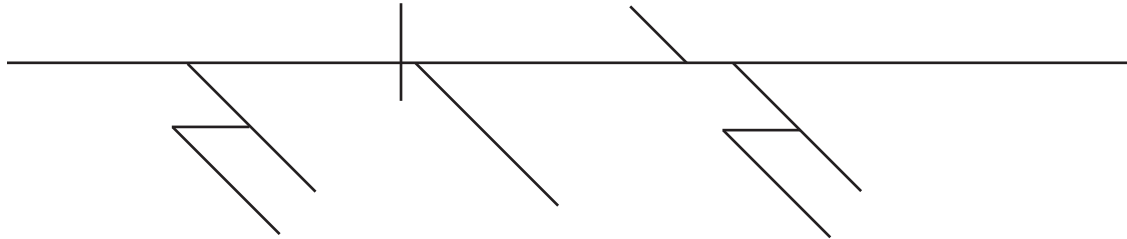

Good baseball bats are more and more expensive.

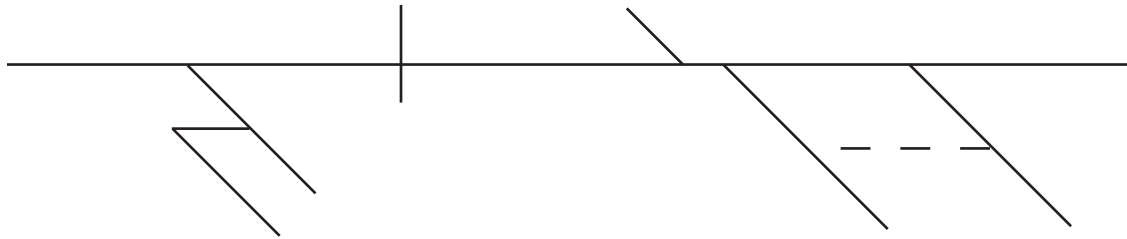

PHRASES IN GENERAL

Noun Phrases

Prepositional Noun Phrases

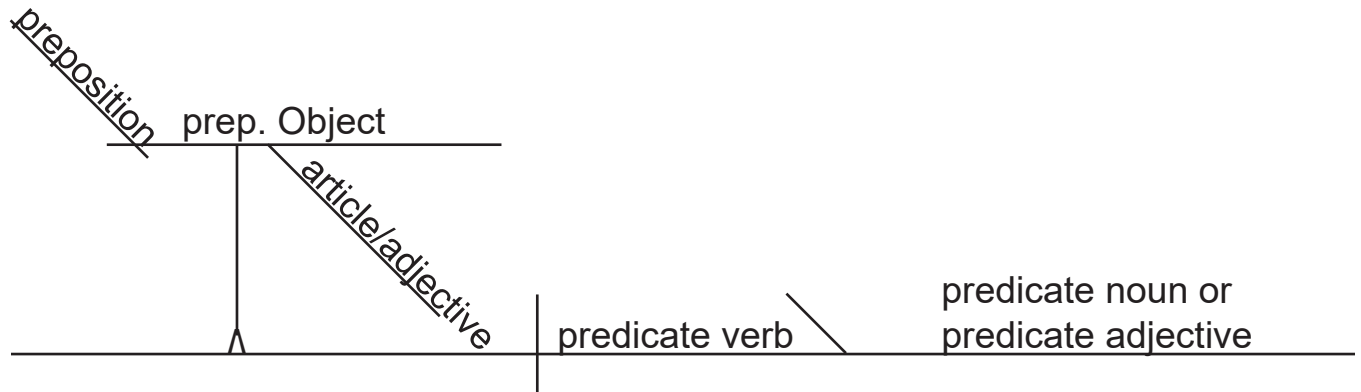

Across the road is out.

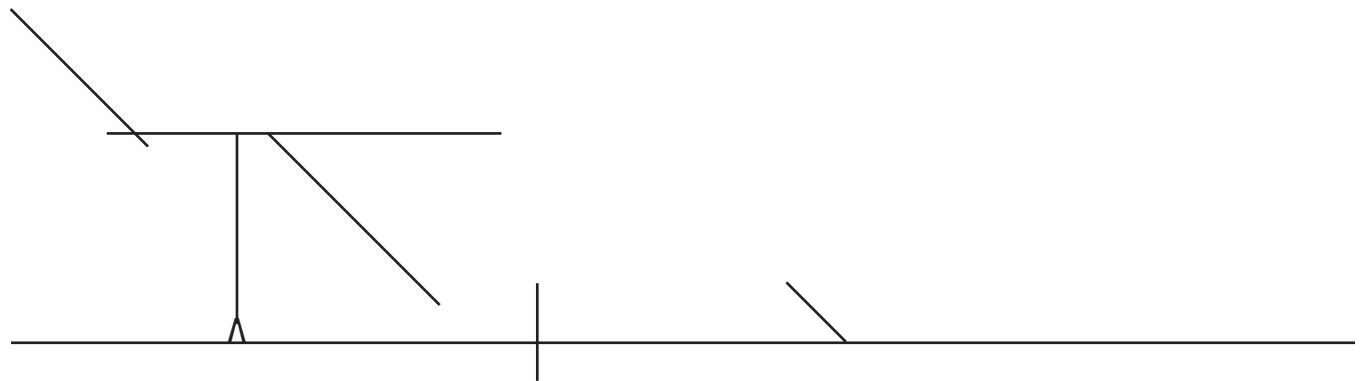

The water is coming from under the garage.

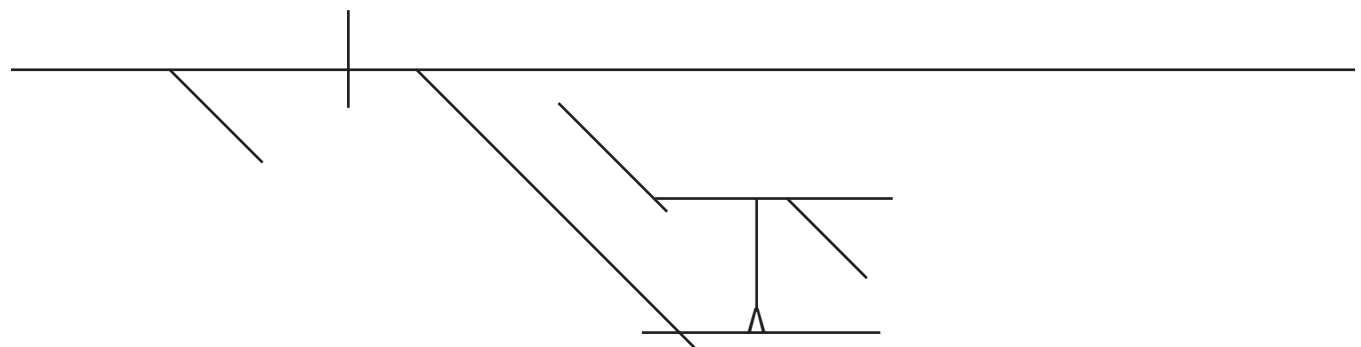

Diagramming Worksheets Name: _____

Gerund Noun Phrase

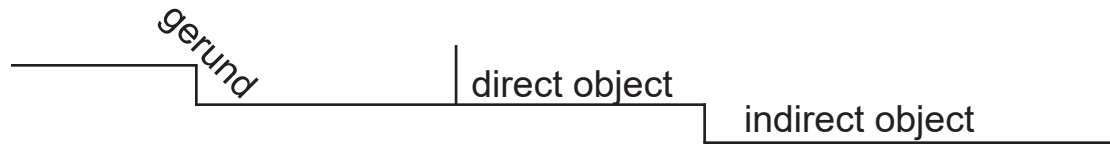

Calling your friend names can be hurtful.

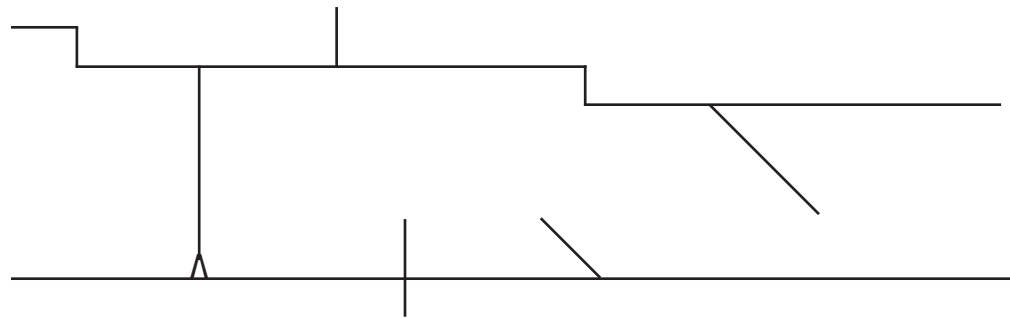

Riding roller coasters is exciting.

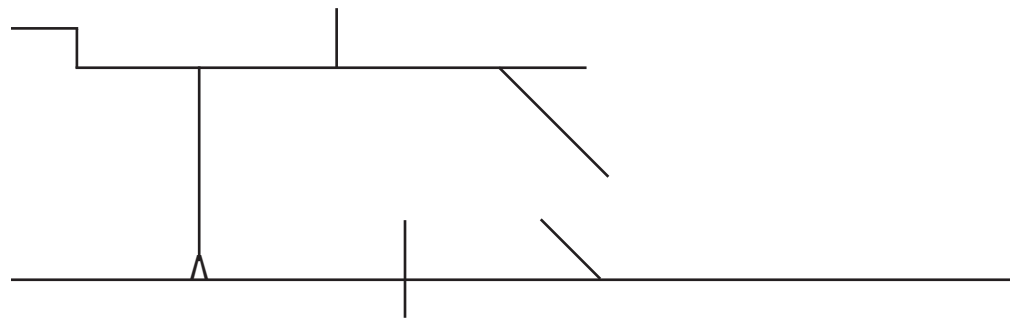

Baking a cake requires a timer.

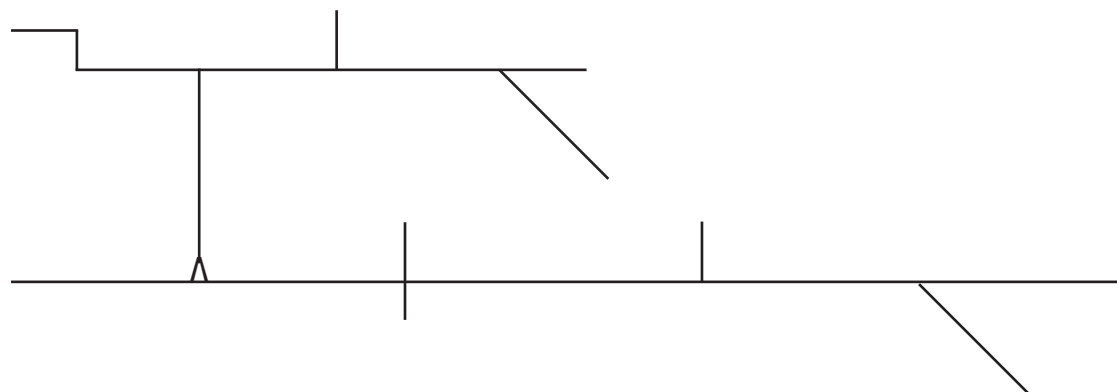

Diagramming Worksheets Name: _____

Infinitive Noun Phrase



To speak is important this time.

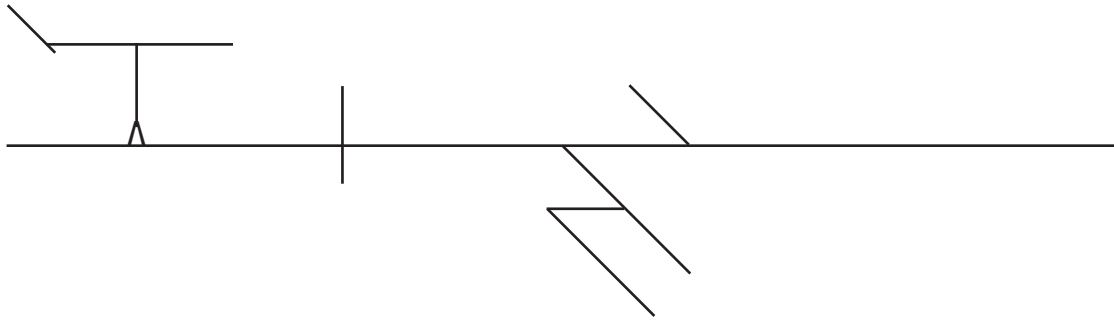

To study well requires patience.



The students are to leave later.

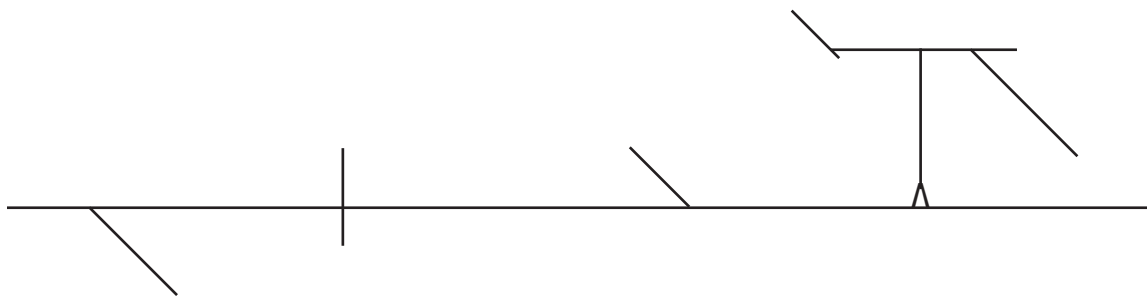

We ought to sound the alarm.

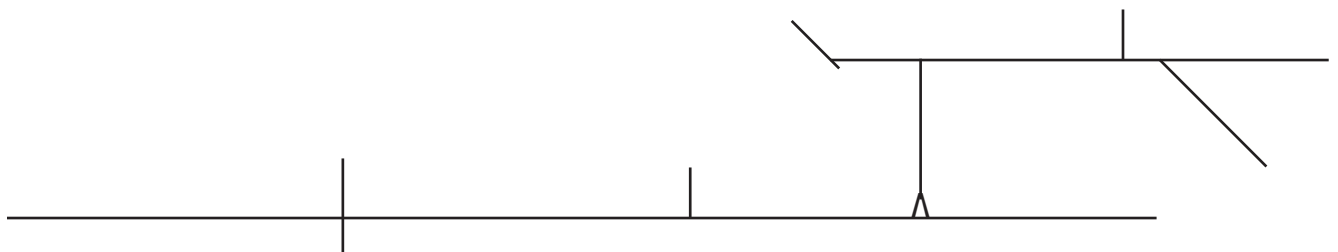

Diagramming Worksheets Name: _____

Prepositional Adjective Phrases

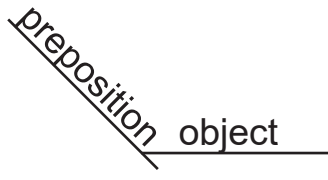

She wants one with a flower.

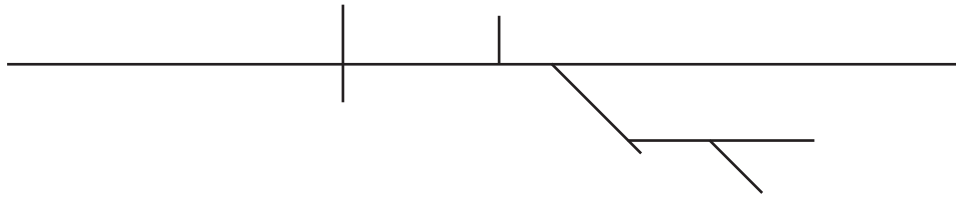

He needs one with a shield.

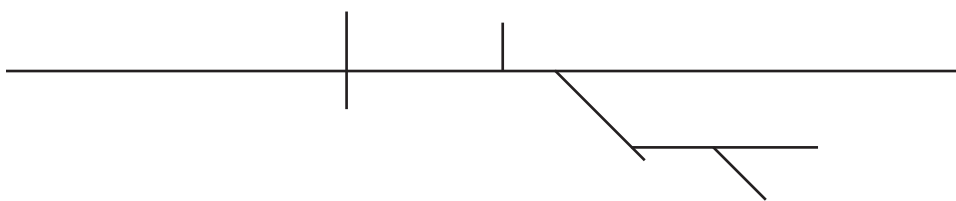

It requires tools from the shop.



The benefit of praying is great.

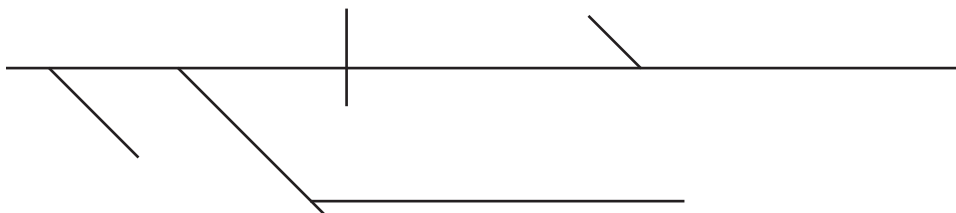

Diagramming Worksheets Name: _____

Prepositional Adverb Phrases - Adverbial Phrases

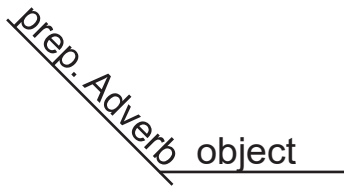

She is charmed by the puppy.

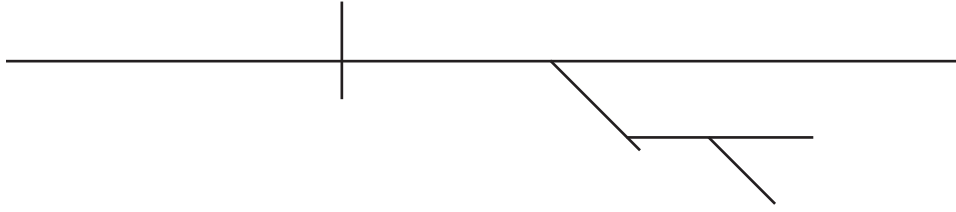

He ran daily around the park.

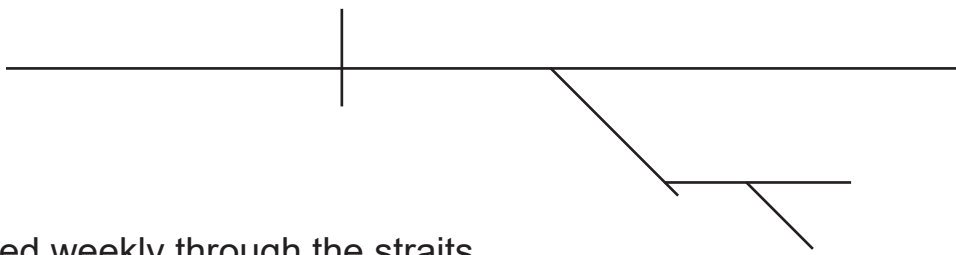

It sailed weekly through the straits.

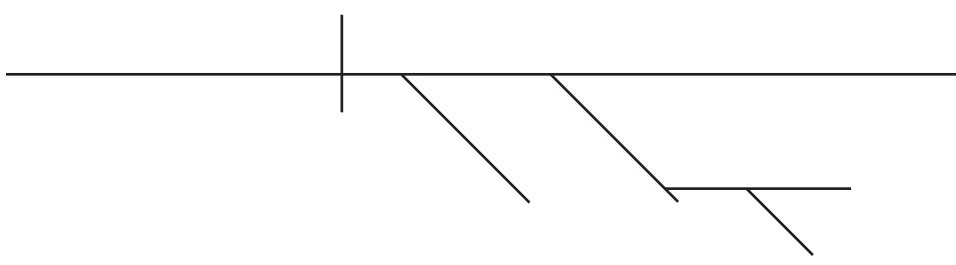

Diagramming Worksheets Name: _____

Appositives

head word (appositive)

My daughter Anna is the girl for the job.

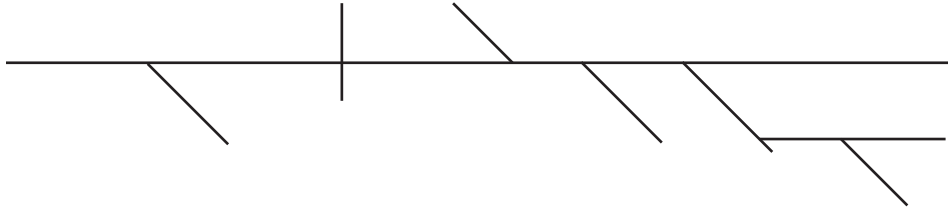

My teacher Mrs. Henry told us the story.

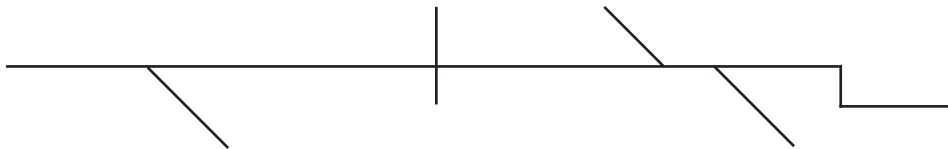

Your church St. Anne's is old.

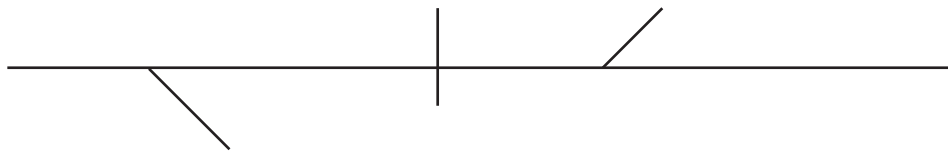

His school Kent Academy is brand new.

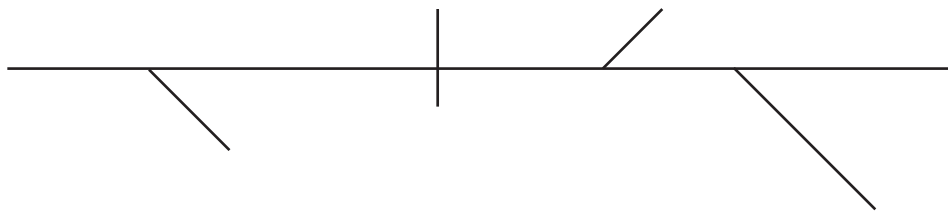

Our boss Mark needs help.

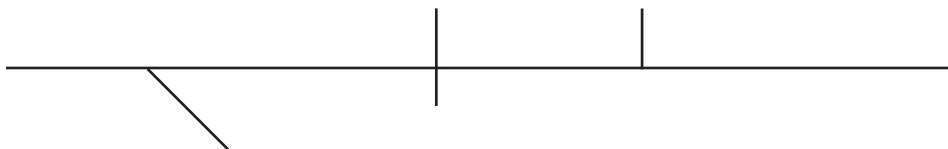

Your coach Frank taught you well.

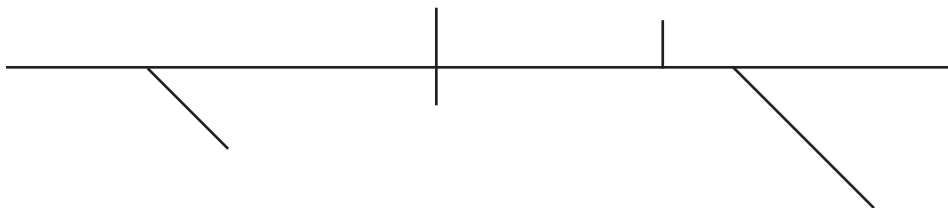

Diagramming Worksheets Name: _____

Possessive Adjectives

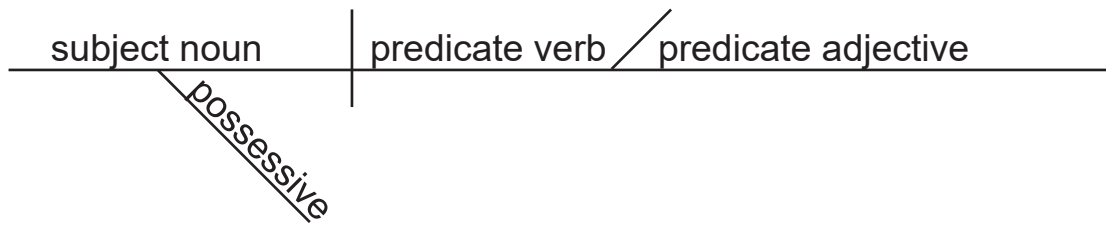

His story is tragic.

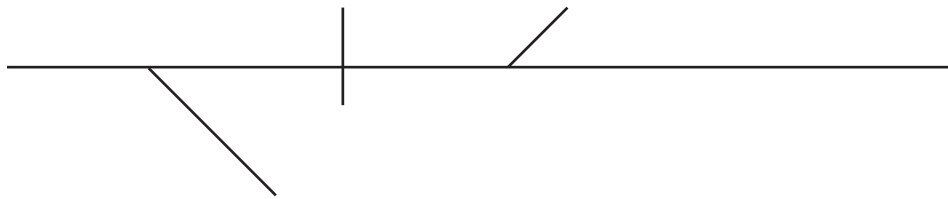

Moses' trip was steep.

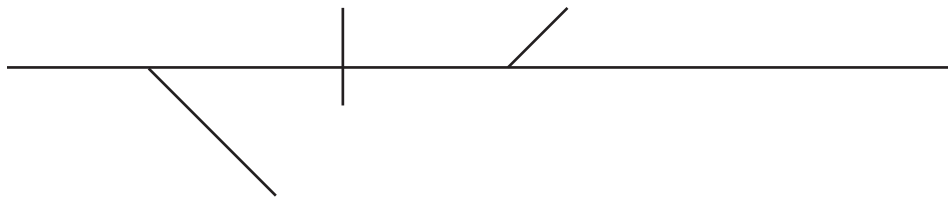

My nose is cold.

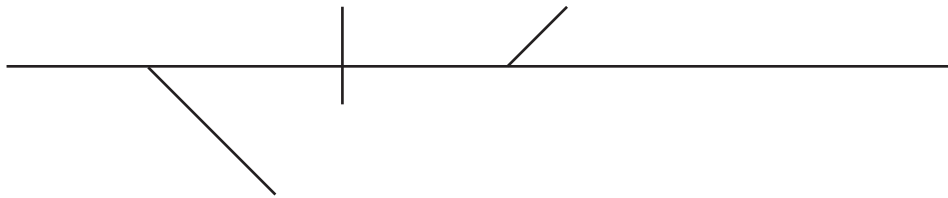

Your hat is lost.

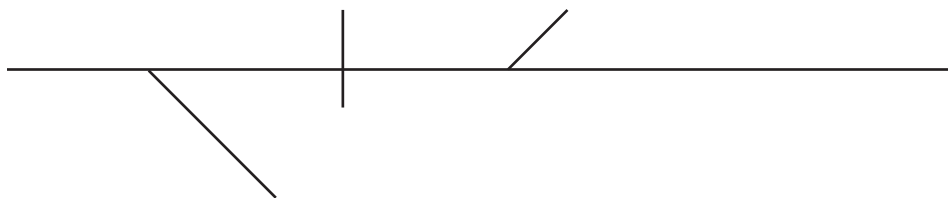

Her coat is pretty.

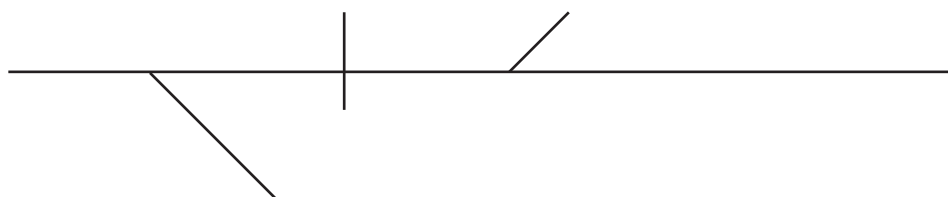

Diagramming Worksheets Name: _____

Direct Address (Like dummy subjects and exclamations)

direct address



Michael, pass the salt.

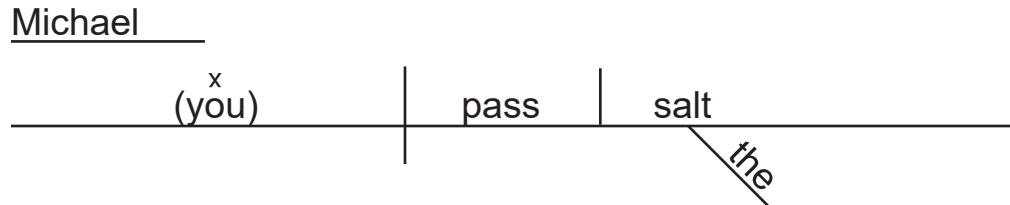

Chris, move the statue.

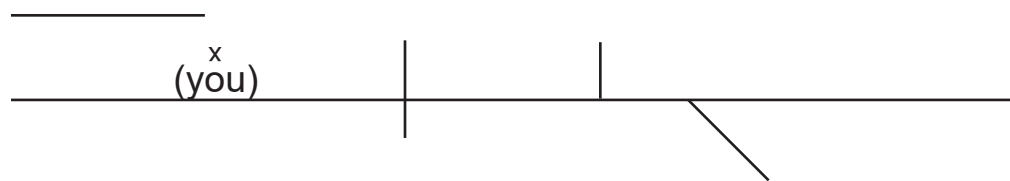

Andrew, carry this quiver.

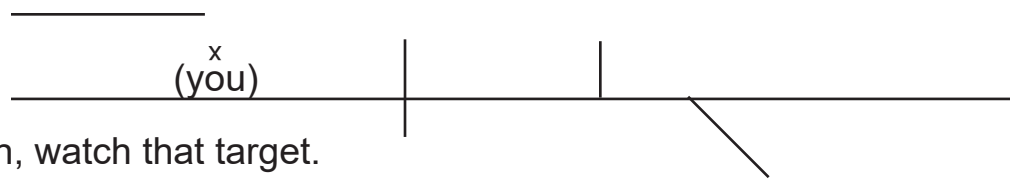

Justin, watch that target.

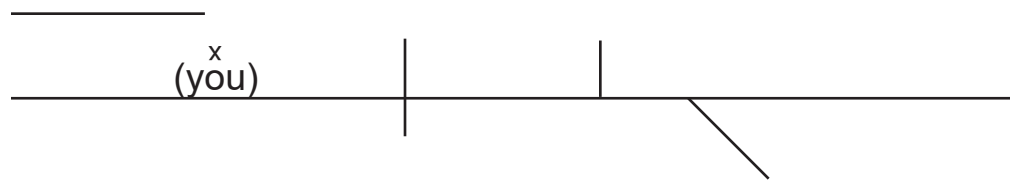

Brendan, ride this horse.



Diagramming Worksheets Name: _____

Exclamations (Like dummy subjects and direct address)

exclamation

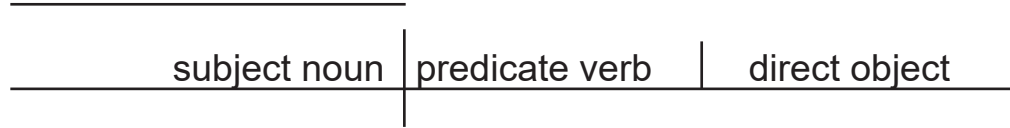

Oh! Look here.



Goodness! You surprised me.

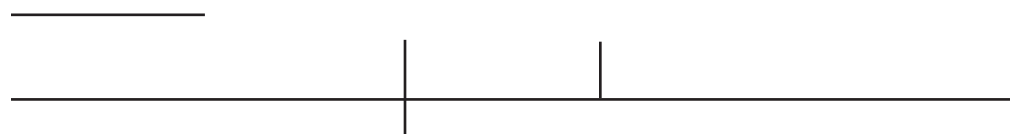

Look! We found it.

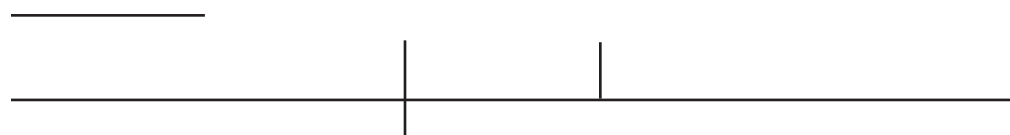

Please! You must eat lunch.



Ah! Silence is a treasure.

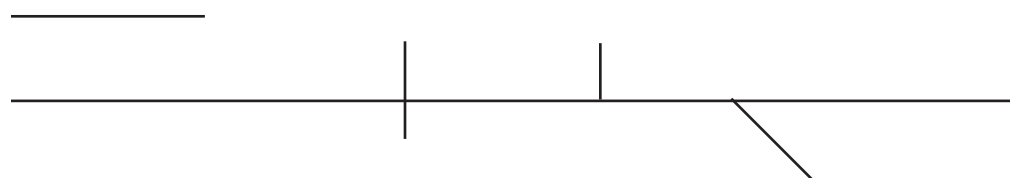

Diagramming Worksheets Name: _____

DIAGRAMMING COMPOUND SENTENCES

A compound sentence, according to STRUCTURE, is a sentence made up of TWO or more independent clauses that are connected by punctuation or conjunctions. Diagram compound sentences in the same manner as simple sentences except show the connection between the clauses. When a compound sentence omits to use the conjunctions and, or, nor, but, yet, or for (FANBOY) between clauses add a semicolon between them in the diagram.

Subject Noun And Predicate Verb

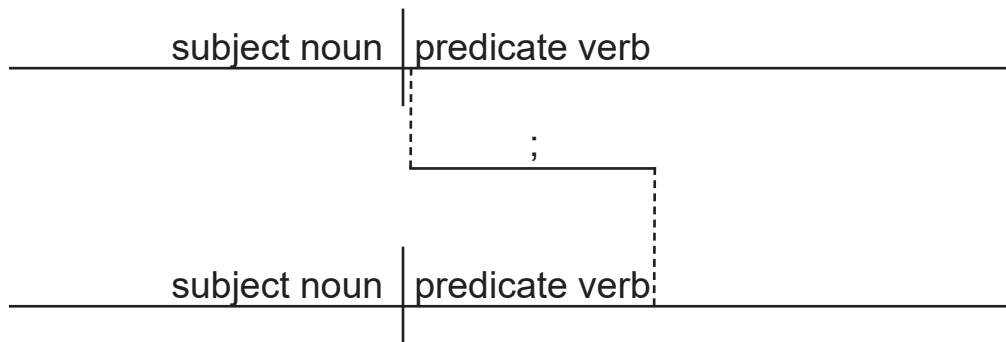

He ran; she walked.

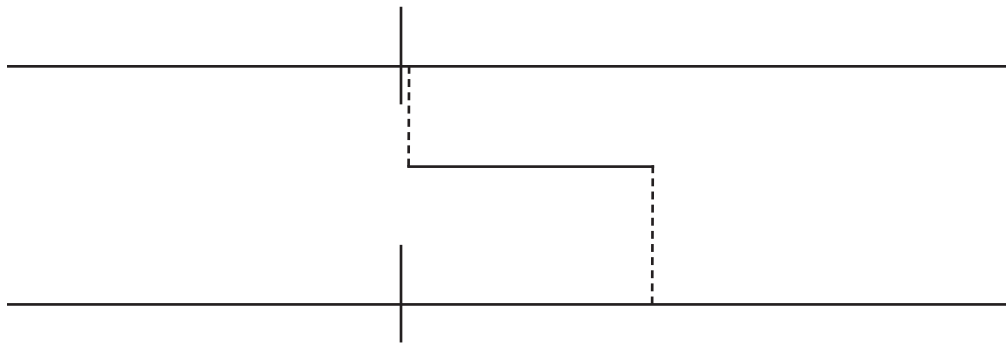

Tip: When and, or, nor, but, yet, or for (FANBOY) are used between the clauses of a compound sentence, place the conjunction on the line between the clauses.

He ran and she walked.

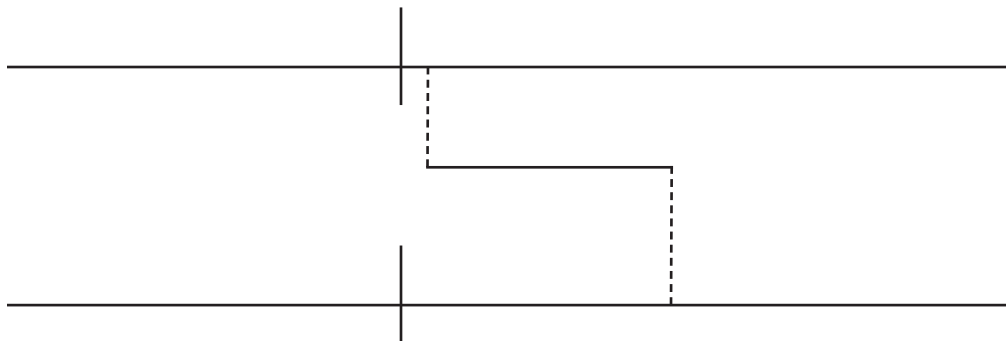

Diagramming Worksheets Name: _____

DIAGRAMMING COMPLEX SENTENCES

A complex sentence, according to STRUCTURE, is a sentence that is made up of ONE independent clause AND ONE OR MORE dependent clauses.

- Put a dependent noun clause on a stilt where it would go as a subject or object and write any subordinating conjunction on the stilt line.

Subject Noun And Predicate Verb

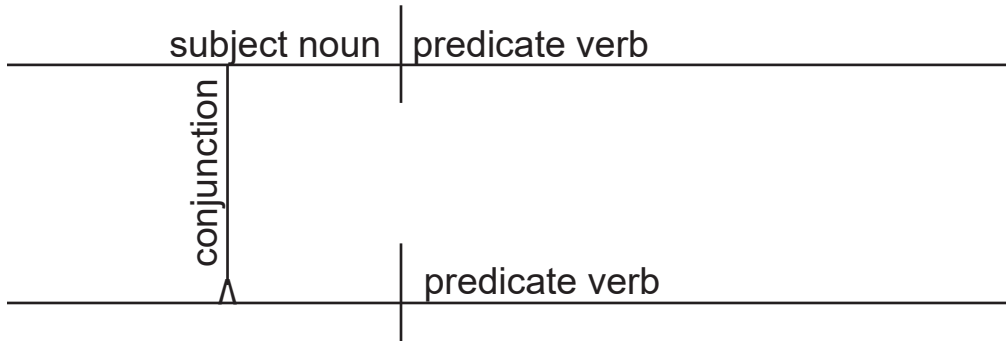

Where he went is known now.

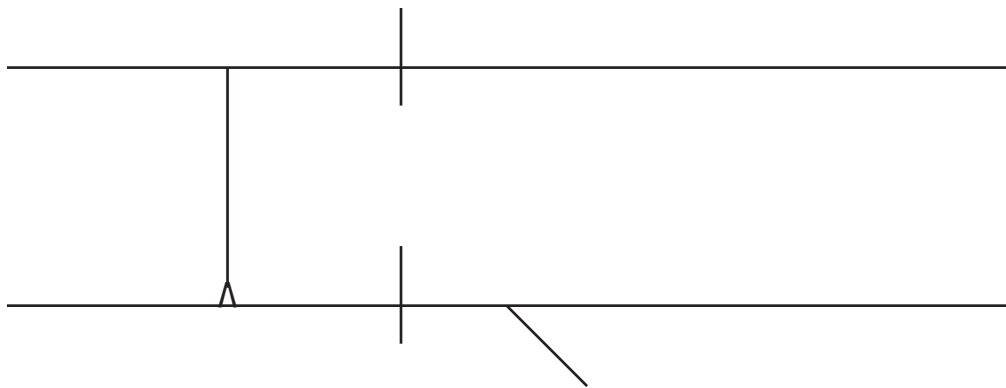

Diagramming Worksheets Name: _____

Adjective Clause

Draw a line to a dependent adjective clause from the noun or pronoun (antecedent) that it describes to the subordinating conjunction.

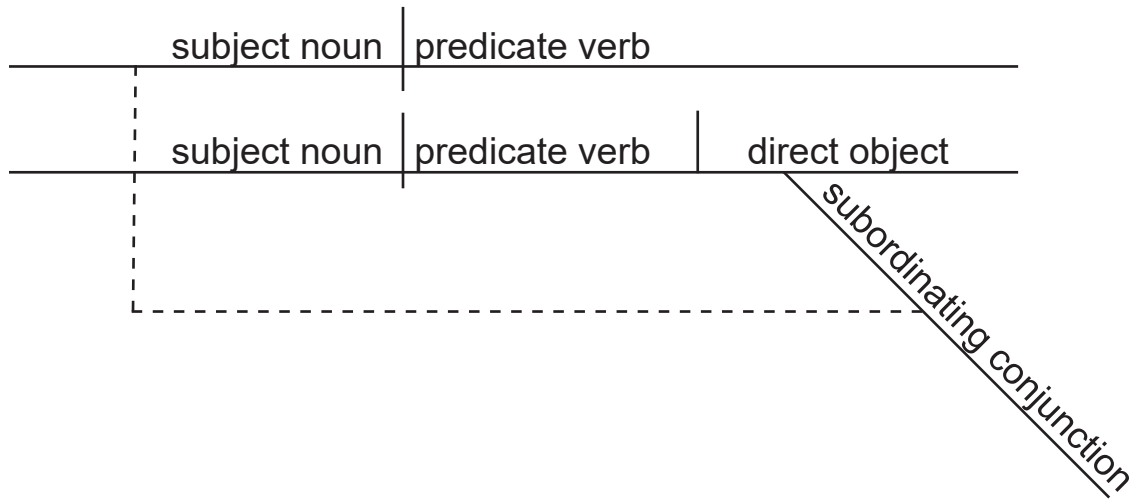

Walsh, whose biography you have read, has died.

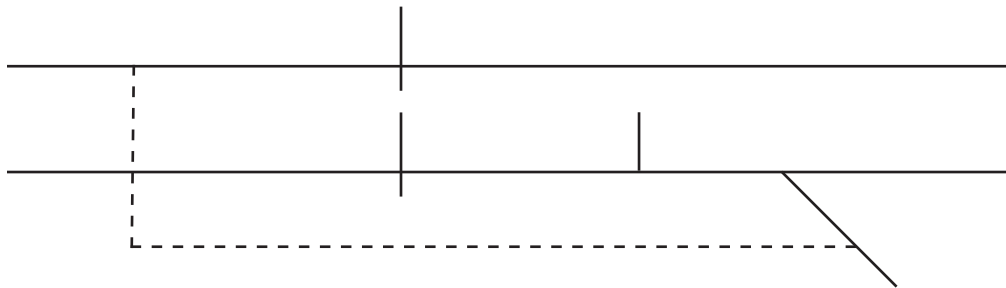

Draw a dotted line to a dependent adverb clause to the predicate verb that it describes and write the subordinating conjunction on the dotted line.

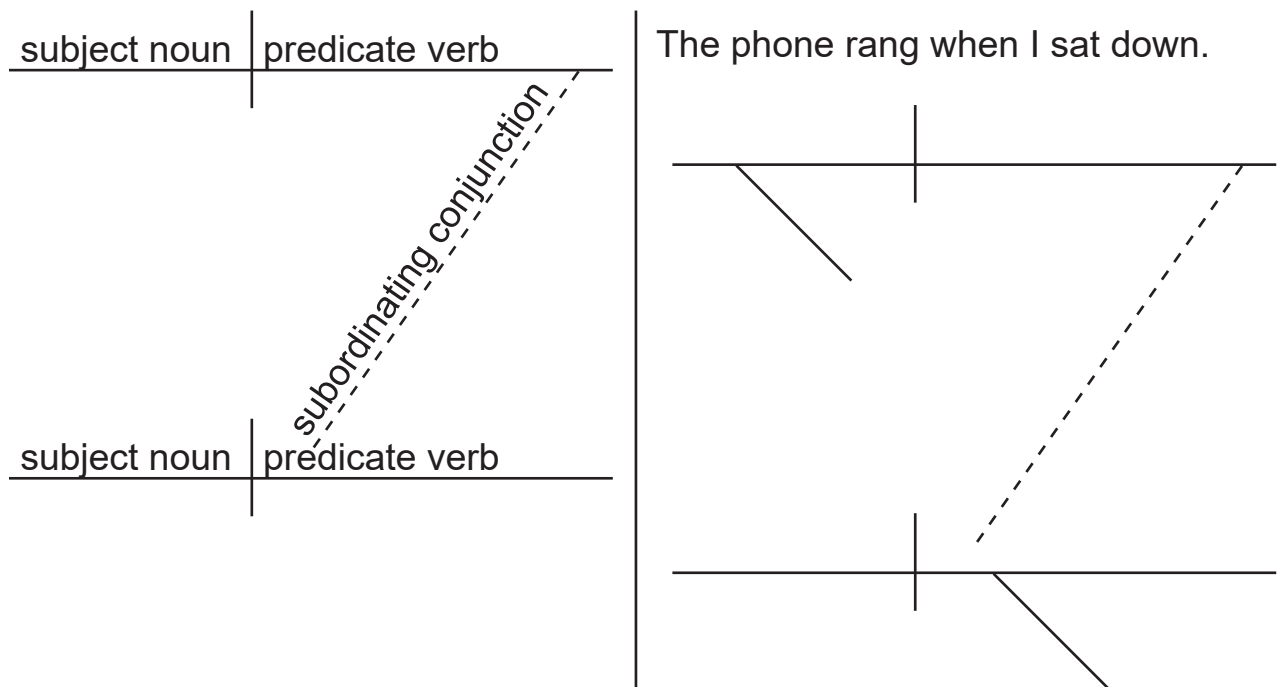

Diagramming Worksheets Name: _____

DIAGRAMMING COMPOUND COMPLEX SENTENCES

A compound-complex sentence, according to STRUCTURE, is a sentence that has TWO or more independent clauses AND one or more dependent clauses. Again, simply connect the different phrases with their conjunction, subordinating conjunction or semicolon.

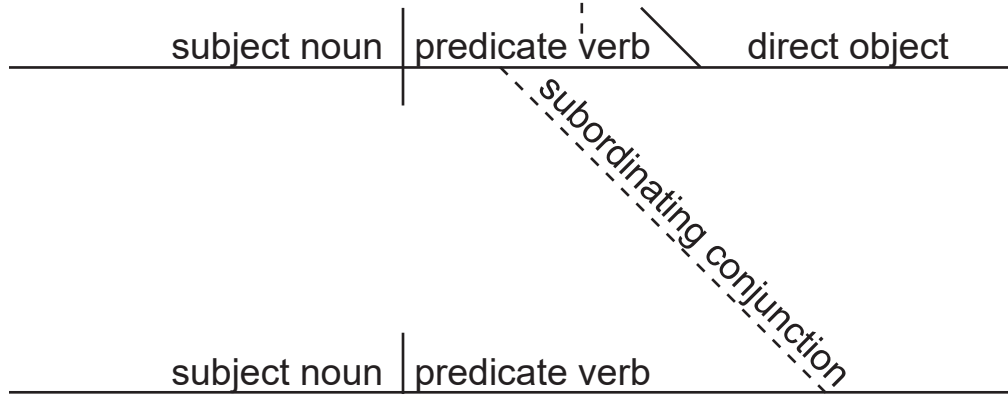
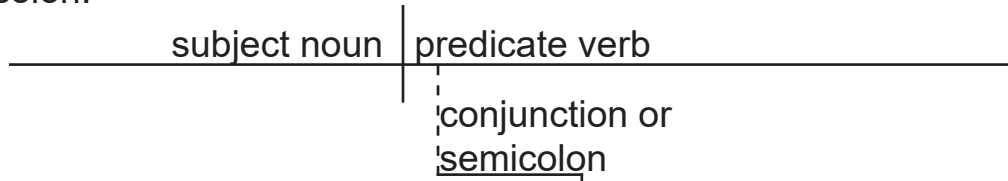

John watched; but, when night fell, the soldiers returned.

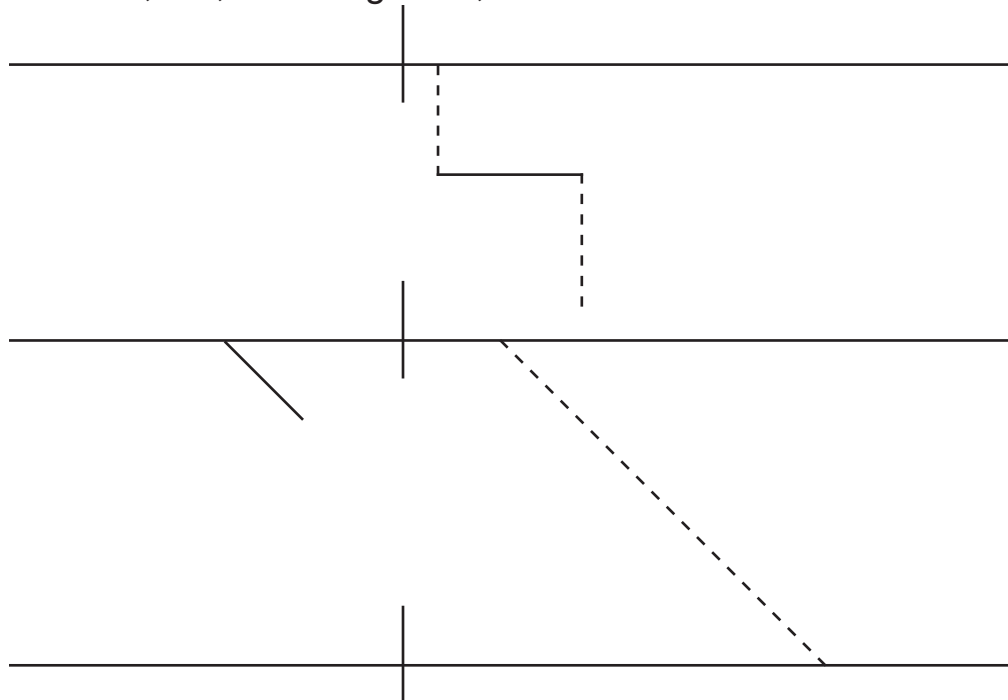

Diagramming Worksheets Name: _____

DIAGRAMMING DIRECT QUOTATIONS

When the quote is a partial sentence that is part of the host sentence, diagram it as part of the sentence or clause.

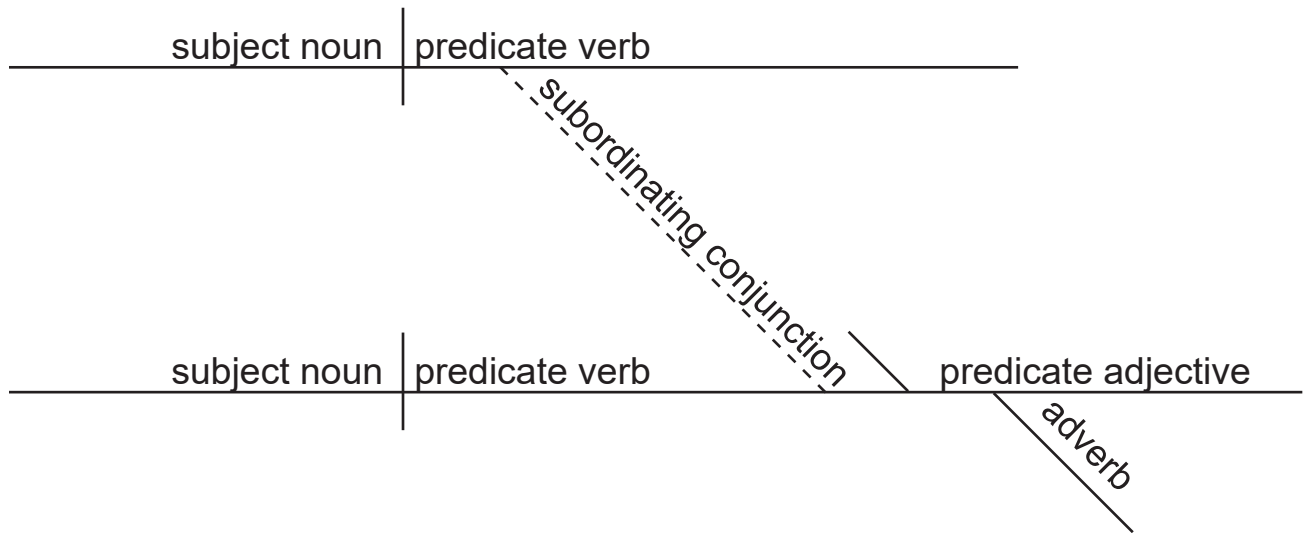

She exclaimed that it was "pretty cute"!

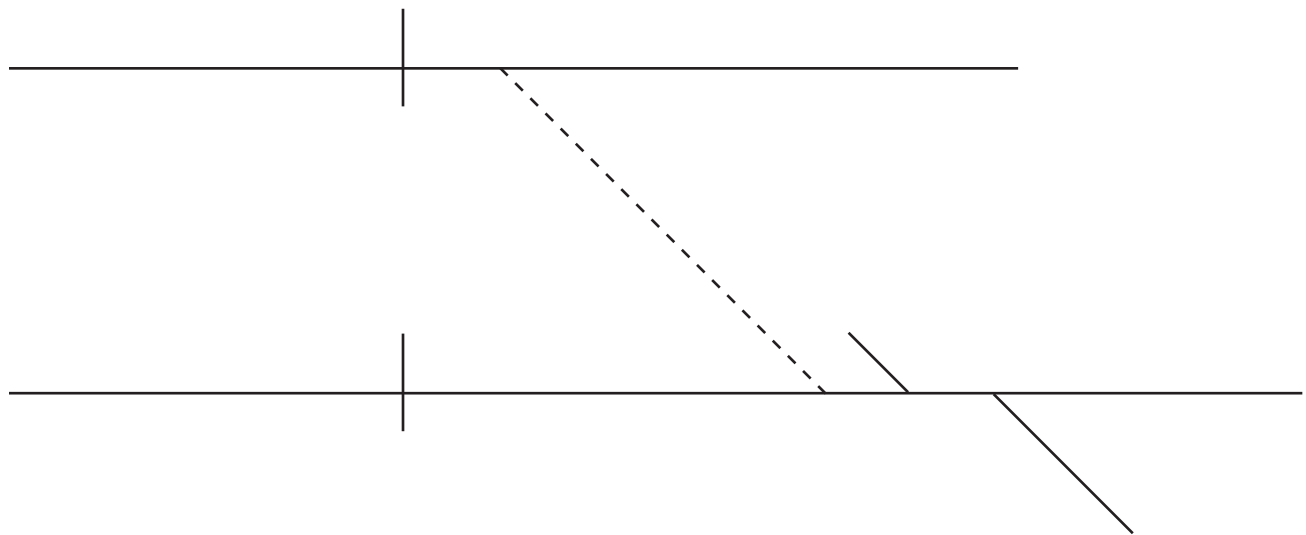

When the quote is a full sentence diagram it as a sentence and diagram the HE SAID portion independently of the quote.

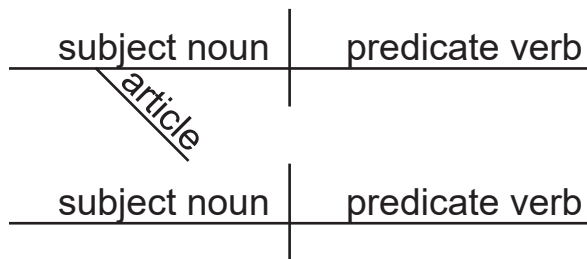

The Bible said, "Jesus wept."

