

# Aerosol Science and Technology: History and Reviews

Edited by David S. Ensor

**RTI** Press

 **RTI**  
INTERNATIONAL

©2011 Research Triangle Institute.

RTI International is a trade name of Research Triangle Institute.

All rights reserved. Please note that this document is copyrighted and credit must be provided to the authors and source of the document when you quote from it. You must not sell the document or make a profit from reproducing it.

Library of Congress Control Number:

2011936936

ISBN: 978-1-934831-01-4

doi:10.3768/rtipress.2011.bk.0003.1109

[www.rti.org/rtipress](http://www.rti.org/rtipress)

### **About the Cover**

The cover depicts an important episode in aerosol history—the Pasadena experiment and ACHEX. It includes a photograph of three of the key organizers and an illustration of a major concept of atmospheric aerosol particle size distribution. The photograph is from Chapter 8, Figure 1. The front row shows Kenneth Whitby, George Hidy, Sheldon Friedlander, and Peter Mueller; the back row shows Dale Lundgren and Josef Pich. The background figure is from Chapter 9, Figure 13, illustrating the trimodal atmospheric aerosol volume size distribution. This concept has been the basis of atmospheric aerosol research and regulation since the late 1970s.

This publication is part of the RTI Press Book series.

RTI International

3040 Cornwallis Road, PO Box 12194, Research Triangle Park, NC 27709-2194 USA

[rtipress@rti.org](mailto:rtipress@rti.org)

[www.rti.org](http://www.rti.org)

# History of Virtual Impactors

Virgil A. Marple and Bernard A. Olson

## Introduction

The virtual impactor is a subclass of the conventional inertial impactor. The conventional impactor accelerates a jet of air through a nozzle and directs it at an impaction plate, as Figure 1A shows. The impactor will separate particles with sufficient inertia from the air stream; these particles will then impact on the impaction plate. A virtual impactor replaces the impaction plate with a collection probe, as Figure 1B shows; it separates the particles that would be collected on the impaction plate of a conventional impactor from the air stream inside the collection probe and flushes them out of the collection probe with a small fraction of the total flow (i.e., the “minor flow”). The larger portion of the flow (i.e., the “major flow”) passes out the side of the virtual impactor, carrying with it particles too small to be captured in the minor flow.

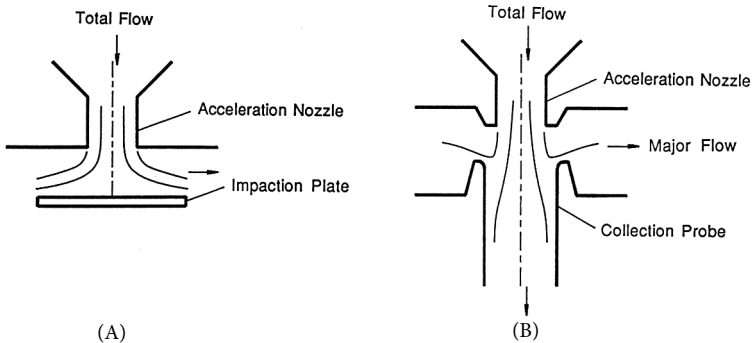

Figure 1. (A) Conventional plate (or jet) impactor and (B) virtual impactor.

In the limited number of pages that this book can allot to describing the history of virtual impactors, it would be impossible to list and discuss every paper that has been written on virtual impactors. In the interest of covering virtual impactor history and not performing a total review of virtual

impactors, we have limited the time span of our history from the origin of virtual impactors through the year 2000. Thus, this chapter investigates the origin of the virtual impactor, reviews some studies on the general flow fields and particle collection characteristics, discusses problem areas and unique variations that make the virtual impactor an interesting and versatile particle sampler, and finally, explores the role of the virtual impactor as a particle concentrator.

### **Origin of the Virtual Impactor**

Many papers written on virtual impactors credit the centripeter with being the first virtual impactor (Hounam & Sherwood, 1965). However, according to David Ensor (personal communication, February 2, 2006), the centripeter may not have been the original virtual impactor but just the first such device to be reported in the literature; also, as we explain in this chapter, the centripeter itself is not a virtual impactor. Ensor's communication states:

I had a discussion on that topic [the origin of virtual impactor] with Bill Conner about 20 years ago. Bill said that the assignment to make a particle separator was his first when he started with the USPHS [US Public Health Service] in the early 1960s. He also said that he successfully developed the device but did not publish anything for a few years. He also claimed that Hounam visited his lab in Cincinnati, got all excited about his device and got inspired to develop the Centripeter. Further, Conner claimed that the reason that he finally published in 1966 was because Hounam published the Centripeter paper based on extending Conner's unpublished idea. (Ensor, personal communication, February 2, 2006)

Investigation into the centripeter article (Hounam & Sherwood, 1965) and the article by Conner (1966) indicates that Conner's claim is probably correct. For example, Conner's paper describes an analysis of particle trajectories and states that "the converging air entering the tube tends to throw the larger particles toward the axis of the tube." He also shows that a perfectly sharp cut can be obtained if all particles are on the centerline of the flow. The centripeter article indicates that focusing the large particles into the center of the flow and then collecting only the particles near the centerline are the goals of the centripeter design. Figure 2 and the following statement illustrate these goals:

Fine particles will travel with the air stream, while coarse particles originally on the axis of the orifice will be carried in the center of the stream and be trapped in the nozzle. Coarse particles approaching the orifice radially will be carried by their momentum across the flow lines to the axis of the orifice and again be collected in the nozzle. (Hounam & Sherwood, 1965)

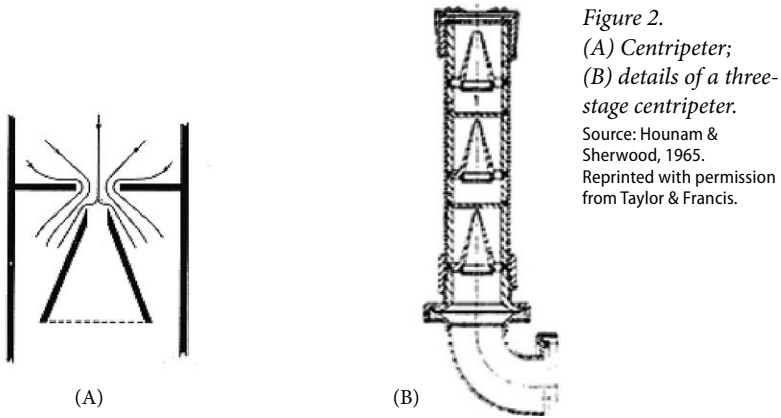

Figure 2.  
(A) Centripeter;  
(B) details of a three-stage centripeter.  
Source: Hounam & Sherwood, 1965.  
Reprinted with permission from Taylor & Francis.

Figure 2 also shows that each stage of the centripeter actually comprises a focusing lens followed by a centerline particle skimmer; thus, the centripeter is not a virtual impactor as Baron and Willeke (2001) define it in Appendix A (glossary of terms) of their book *Aerosol Measurement*. This definition states that a virtual impactor is

a device in which particles are removed by impacting them through a virtual surface into a stagnant volume, or a volume with a slowly moving air flow, so that large particles remain in this volume, while smaller particles are deflected with the bulk of the original air flow. (Baron & Willeke, 2001)

The diameters of the collection probes of the centripeter are half the diameter of the nozzles for all stages, and the collection probe does not create the virtual surface below the nozzle that the definition for virtual impactors describes. Thus, the centripeter is not a virtual impactor but a series of particle-focusing lenses with centerline particle skimmers. Hounam and Sherwood do not claim that the centripeter is the instrument described in Conner's paper, which is a virtual impactor, but authors of subsequent papers on virtual impactors have erroneously referred to the centripeter as a virtual impactor.

We have concluded that the instrument described by Conner (1966), shown in Figure 3, is the original virtual impactor.

The name “virtual impactor” was not given to this device until later. The US Army coined the term when they were testing a particle concentrator, built by the Environmental Research Corporation (ERC), that was based on a particle classifier similar to the device described by Conner (C. Peterson, personal communication, February 2006). This device (Figure 4) was later studied by Dzubay and Stevens (1975) for application as an ambient sampler and became the first dichotomous sampler. The development of this sampler eventually led to the widely used dichotomous virtual impactor sampler developed by Loo et al. (1976), shown in Figure 5, for large-scale monitoring of airborne particulate matter. This sampler is probably the most widely used virtual impactor and has been the subject of several studies and reviews

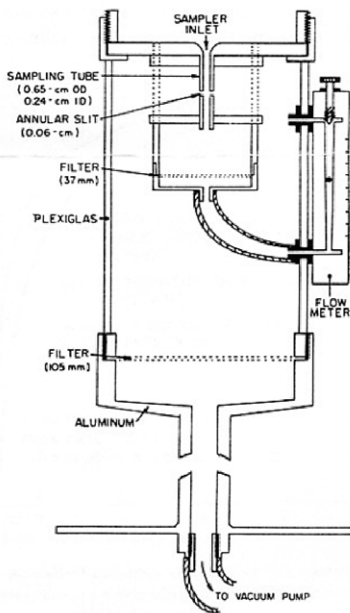

Figure 3. Conner's inertial-type particle separator for collecting large samples (the first virtual impactor).

Source: Conner, 1966. Reproduced with permission from the Air and Waste Management Association, *Journal of the Air Pollution Control Association*. Permission via the Copyright Clearance Center.

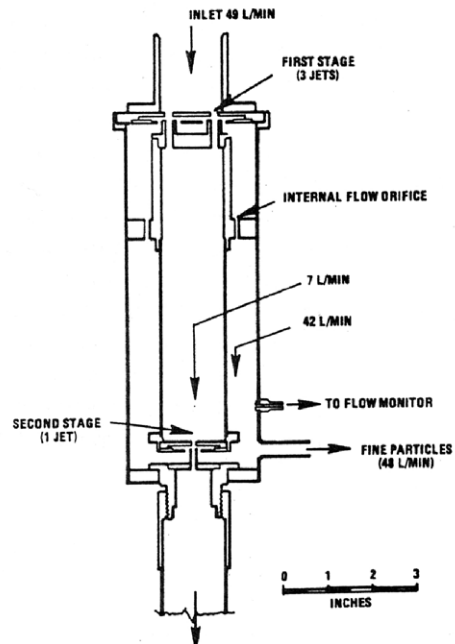

Figure 4. First virtual impactor-based dichotomous sampler.

Source: Dzubay & Stevens, 1975. Reprinted with permission from the American Chemical Society.

(Loo & Jaklevic, 1974, 1979; Loo et al., 1976; Loo & Cork, 1988; McFarland et al., 1978; US Patent No. 4,301,002, 1981). Thus, between 1966 and 1976, the virtual impactor went from a discovery to a widespread application in a network of ambient air samplers.

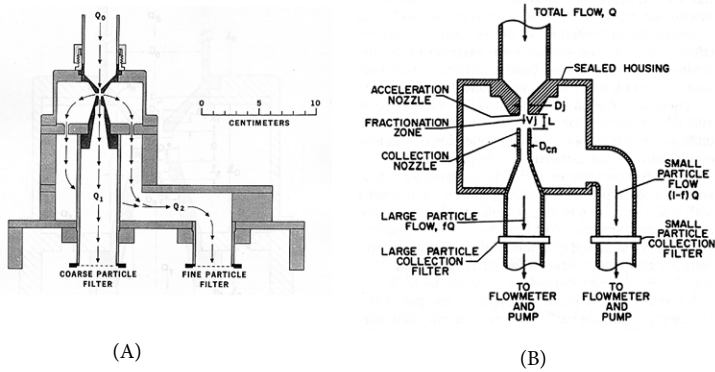

Figure 5. Dichotomous virtual impactor sampler.

Source: (A) Loo et al. 1976; (B) McFarland et al. 1978.

## General Studies of Virtual Impactors

Some studies have examined how certain parameters (airflow and geometry) affect the separation of particles in a virtual impactor. These parameters include a wide variety of geometric parameters, the flow split ratio between the minor and major flows, and the Reynolds number of the flow through the acceleration nozzle.

Forney and co-workers studied the influence of flow field and slit virtual impactors on particle separation (Forney, 1976; Forney et al., 1978, 1982; Ravenhall et al., 1978). They assumed ideal fluid flow and used a coordinate transformation technique to map the flow field and a water model with dye streamlines to trace the flow streamlines. Han and Moss (1997) conducted a water model flow visualization study of round nozzle virtual impactors. Although their work was to study clean core virtual impactors, figures in the article provide insight into the flow fields in round nozzle virtual impactors.

A theoretical analysis of round nozzle virtual impactors, performed by Marple and Chien (1980), solved the complete Navier-Stokes equations using computational fluid dynamics (CFD) analysis to determine the flow fields.

They then traced particle trajectories through these flow fields by numerically solving the particle equations of motion, using a Runge-Kutta integration technique. This technique allowed Marple and Chien to determine the particle collection efficiencies in the minor flow and major flow, as well as wall losses. Upon developing this analysis technique, Marple and Chien performed a parametric study to determine the influence of parameters, such as jet Reynolds number, minor flow rate ratio, collection probe/nozzle diameter ratio, nozzle length, entrance cone angle, nozzle-to-collection probe distance, and several collection probe entrance configurations on the minor flow and major flow particle collection efficiency and wall loss curves.

Loo and Cork (1988) conducted an experimental study on the effect of geometric configurations on the performance of the  $2.5\ \mu\text{m}$  dichotomous sampler. They investigated the effect of 27 geometric parameters on the particle collection efficiency curves and on particle losses within the virtual impactor.

Xu (1991) studied the effect of nozzle and collection probe design and minor flow ratio on the performance of round jet virtual impactors. His basic test apparatus, shown in Figure 6, consisted of a frame in which he could insert different nozzles and collection probes and then determine the particle losses for these two components as well as the particle collection curves.

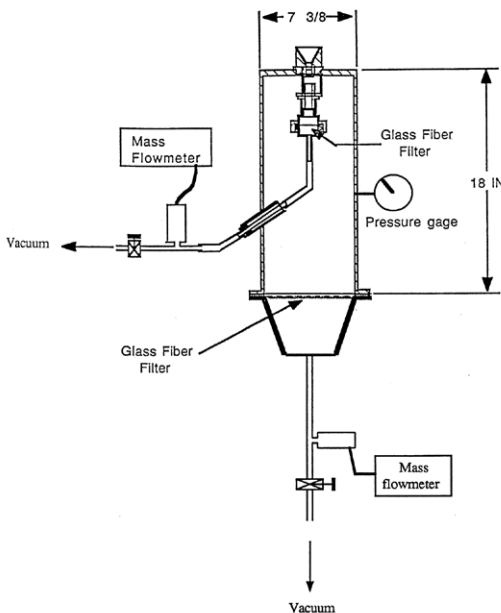

*Figure 6. Test apparatus for evaluating different nozzle/collection probe designs.*  
Source: Xu, 1991.



## Problem Areas of Virtual Impactors and Solutions

The virtual impactor was developed to sample large quantities of particles without the problems of particle bounce and fragile particle shattering inherent to traditional impactors. However, the virtual impactor has its own problems, including internal particle losses and contamination of the large particle fraction with small particles in the minor flow. For example, if the minor flow is 10 percent of the total flow, 10 percent of the small particles end up in the minor flow with the large particle fraction, essentially “contaminating” the large particle fraction with small particles.

### Internal Losses

The problem of internal losses, which normally occur in the entrance of the collection probe or on the backside of the nozzle, cannot be completely eliminated. However, proper design of the virtual impactor components can reduce internal losses. For example, Loo and Cork (1988) identified 27 geometric parameters in the design of the virtual impactor. They suggested ranges for these parameters that would optimize the virtual impactor design; however, because this work was based around the design of a single instrument operation at a single total flow rate and minor flow rate (i.e., the dichotomous sampler), only a limited number of his suggested parametric ranges could be used in general virtual impactor designs. Xu (1991) studied Loo’s design and concluded that Loo’s design appeared to be optimized for minimum collection probe tip losses, whereas nozzle backside losses increased with decreasing minor flow rate ratio. Xu was able to solve this problem using a protruding nozzle (Figure 7). This modification allowed the small particles exiting the collection probe to reduce their velocity so that they would not impact on the backside of the nozzle.

Losses can also occur in the minor flow cavity. The minor flow propels large particles into this cavity at high speeds. If the cavity is not sufficiently long, the particles will impact on the surface opposite the exit of the collection

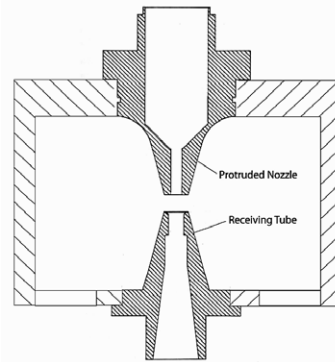

Figure 7. Protruded nozzle.

Source: Xu, 1991.

probe. One solution is to make the minor flow cavity long enough so that the large particles will slow and not impact. This solution results in a rather large virtual impactor minor flow cavity. Another solution to this problem is to use a pair of virtual impactor nozzle/collection probe sets configured so that the outlets of the two collection probes are directed at each other. This was the solution devised by Marple et al. (1990) in the high-volume virtual impactor (HVVI) (Figure 8); this solution allowed for a  $2.5\ \mu\text{m}$  cut size, 40 cfm virtual impactor with a size of only  $16.4 \times 17.1 \times 12.1\ \text{cm}$ . The HVVI was developed for the US Environmental Protection Agency (EPA) for the separation of wood smoke from ambient aerosols in areas in which there were considerable rates of residential fireplace wood burning. Figure 8 also shows that 12 virtual impactor nozzle/collection probe pairs are incorporated in one body. This design is unique in that it includes flow restrictors at the exit of the collection probes so that the minor flow is distributed evenly across the 12 collection probes. Also, multiple nozzles on a single stage, compared with a single nozzle with the same cut size, will have a smaller pressure drop. Marple et al. (1990) showed that the pressure drop is inversely proportional to the number of nozzles to the  $2/3$  power.

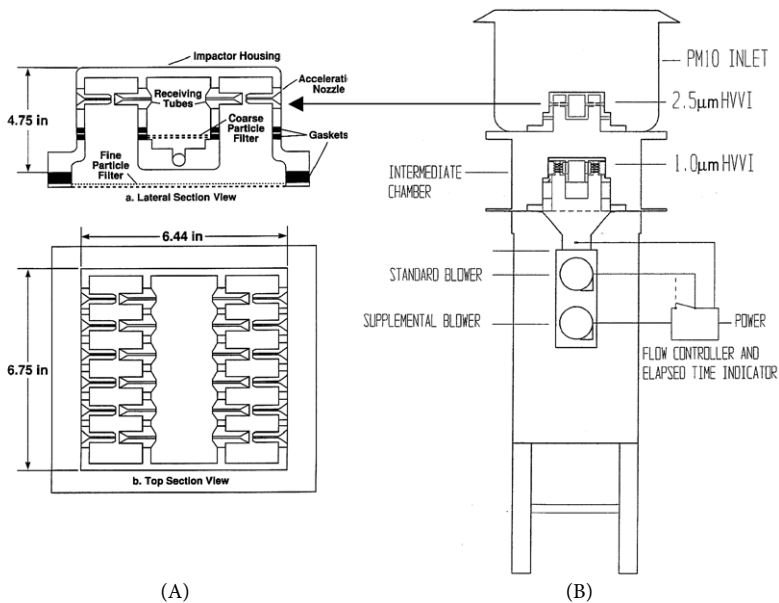

Figure 8. (A) High-volume virtual impactor; (B) high-volume  $\text{PM}_{10/2.5/1.0}$  trichotomous sampler.

Source: (A) Marple et al., 1990. Reproduced with permission from the Air and Waste Management Association, *Journal of the Air Pollution Control Association*. Permission via the Copyright Clearance Center. (B) Marple & Olson, 1995.

### Contamination of Large Particle Fraction by Small Particles

Several widely different approaches can address the problem of small particle contamination in the minor flow. The most obvious solution is to reduce the minor flow ratio. Xu (1991) showed that this was feasible by operating his apparatus at minor flow ratios as low as 0.05 percent. He concluded that 0.1 percent was the practical lower limit.

Another technique is to provide for a core of particle-free air in the center of the flow passing through the nozzle (Masuda et al., 1979; Chen & Yeh, 1987; Chein & Lundgren, 1993; Li & Lundgren, 1997). The clean core virtual impactor designed by Masuda et al. (1979) is shown in Figure 9. With this technique, no small particles enter the minor flow. However, the design of the sampler is much more complex because filtered clean air must be provided at the center of the nozzle; thus, this technique is not practical for multiple nozzle samplers or cascade samplers. The Masuda virtual impactor also introduces a sheath of clean air along the surface of the nozzle. This keeps particles out of the boundary layer along the wall and should provide for sharper efficiency curves and fewer particle losses on the walls of the nozzle.

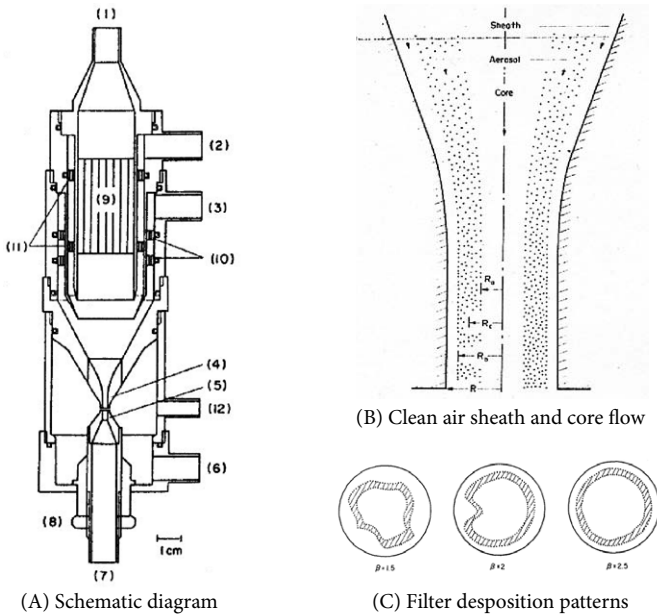

Figure 9. Virtual impactor with a core of clean air to eliminate small particles in the minor flow and a sheath to reduce particle losses.

Source: Masuda et al., 1979. Reprinted with permission from Elsevier.

A third technique is to determine the concentration of the small particles in the major flow and subtract these results from the results of the minor flow. This was used extensively in the high-volume  $PM_{10/2.5/1.0}$  trichotomous sampler, shown in Figure 8b (Marple & Olson, 1995). This sampler determines whether the particles in the 1.0 to 2.5  $\mu\text{m}$  range have the same chemical composition as the particles in the 2.5 to 10  $\mu\text{m}$  size range or in the less than 1.0  $\mu\text{m}$  size range. Thus, the chemical composition of the small particle contamination in the minor flow is important. To solve the problem, the sampler collects particles from the major flow with filters made of the same material and having the same flow rate as the filters used to collect the minor flow particles. One can then subtract the quantity of material captured in the filters in the major flow stream from that captured from the minor flow filter, effectively negating the influence of the small contaminate particles that exist in the minor flow.

## **Unique Designs and Applications of the Virtual Impactor Classifier**

Virtual impactors have been used for some special applications besides particle sampling or particle concentrating. Three types of specialty virtual impactors are multistage (cascade) virtual impactors, cascade impactors used as aerosol generators, and virtual impactors used to deliver respirable particle classification for analysis.

### **Cascade Virtual Impactors**

Novick and Alvarez (1987) designed and calibrated a 2 L/min, two-stage cascade virtual impactor as an alternative to conventional cascade impactors. This sampler, shown in Figure 10, allows for three size classes (two virtual impactor minor flows and an after filter) to be collected on one plane. Novick and Alvarez compared the size distribution defined by the cascade virtual impactor with that of a real cascade impactor and found fairly good agreement in the mass median aerodynamic diameter (MMAD) and the geometric standard deviation (GSD). Although this was only a two-stage sampler, Novick and Alvarez indicated that more stages could be easily added.

Liu et al. (1991) designed and tested the shuttle particle sampler, a somewhat different configuration of a cascade virtual impactor, shown in Figure 11. The cut sizes were 10 and 2.5  $\mu\text{m}$  at a flow rate of 12 L/min. The Space Shuttle *Columbia* used this sampler on board to determine the size of particles that existed inside the shuttle cabin during zero gravity conditions. Liu et al.

collected the particles from the two minor flows and the after filter on filters to determine the particle size distribution and to identify particles by scanning electron microscopy (SEM) and energy dispersive spectroscopy (EDS).

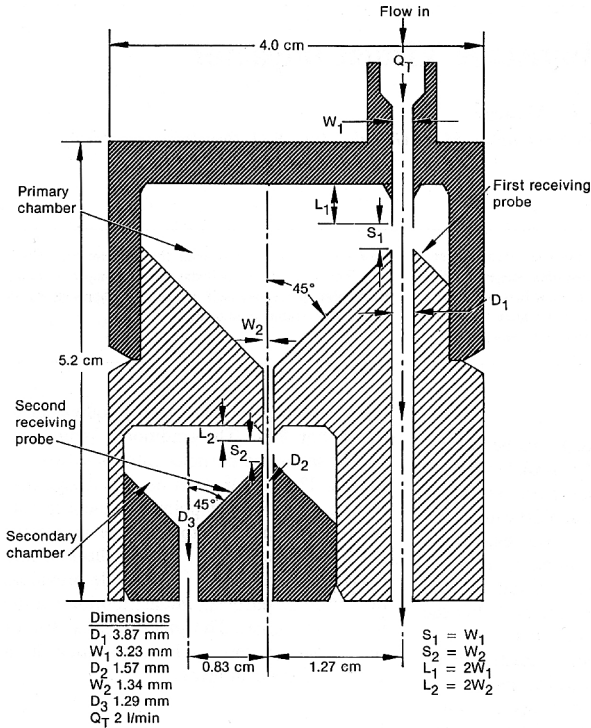
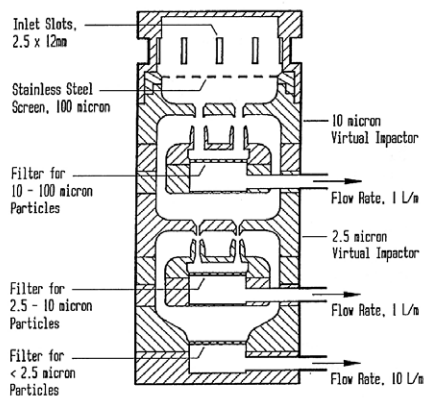
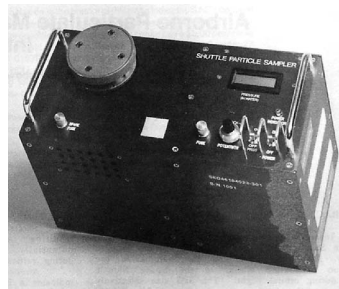

Figure 10. Two-stage cascade impactor.  
Source: Novick & Alvarez, 1987.



(A) Schematic diagram



(B) Enclosure

Figure 11. Virtual impactor used in the Space Shuttle Columbia.

Source: Liu et al., 1991. Reprinted with permission from SAE paper 911476 © 1991 SAE International.

Another cascade virtual impactor, the Respicon, was a personal sampler with time-resolved concentration monitoring designed to provide cuts corresponding to the total, thoracic, and respirable size cuts (Koch et al., 1999; Figure 12). The instrument combined inertial classification, filter sampling, and photometric aerosol detection. It consisted of a two-stage virtual impactor with cut sizes of 4 and 10  $\mu\text{m}$ , three filters, three light-scattering photometers; the instrument operated at a flow rate of 3.1 L/min. Koch et al. calibrated the optical sensors in situ, using the mass concentrations obtained gravimetrically from the filter samples.

The high-volume  $\text{PM}_{10/2.5/1.0}$  trichotomous sampler (Marple & Olson, 1995), shown in Figure 8 and discussed earlier, was also a cascade virtual impactor with cut sizes of 2.5 and 1.0  $\mu\text{m}$  at 1,200 L/min. This sampler was a modified Andersen high-volume sampler and was used for ambient sampling.

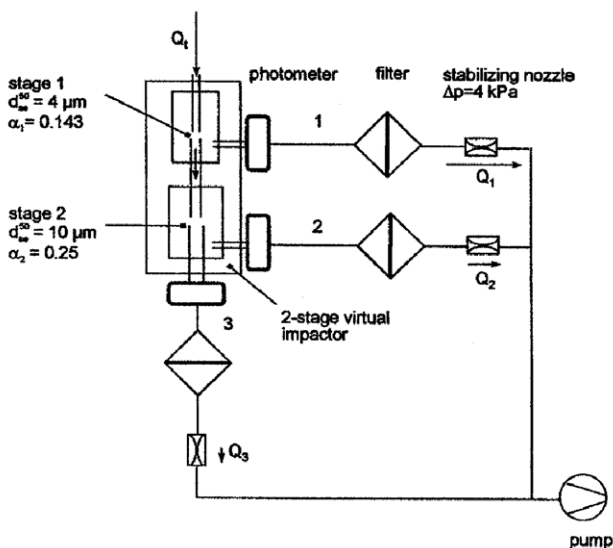

Figure 12. Schematic diagram of Respicon cascade virtual impactor.

Source: Koch et al., 1999.

### Virtual Impactors for Sampling in Dieselized Coal Mines

Diesel powered coal-mining equipment, with the exhaust passing through scrubbers, emitted exhaust particles from the scrubbers that were all less than 0.8  $\mu\text{m}$  in diameter (Rubow et al., 1990). Moreover, coal dust particles resulting from mining operations were all larger than 0.8  $\mu\text{m}$  in diameter. To separate the diesel exhaust particulates from the coal dust particles, Marple et al. (1995) developed a virtual impactor personal aerosol sampler (VIPAS) for

use in diesel-equipped mines. As Figure 13 shows, the sampler consists of a 10 mm respirable cyclone, a 0.8  $\mu\text{m}$  cutpoint virtual impactor, and two filter cassettes. The respirable particles penetrating the cyclone pass through a 0.8  $\mu\text{m}$  cutpoint virtual impactor, which collects the particles larger than (coal dust particles) and smaller than (diesel exhaust particles) 0.8  $\mu\text{m}$  on two 37 mm filter cassettes. The sampling flow rate is 2 L/min, which is compatible with the standard respirable dust sampler and personal sampling pumps.

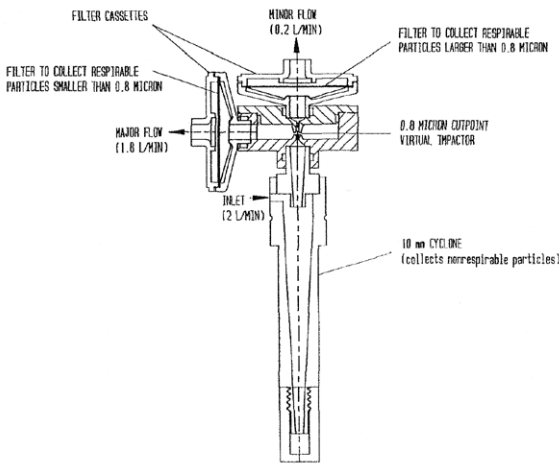

Figure 13. Schematic diagram of virtual impactor personal aerosol sampler

Source: Marple et al., 1995.

### Virtual Impactors in Dust Generators to Provide Narrow Size Distributions

By passing a broad distribution aerosol through two virtual impactors with different cut sizes, one can remove the small particles in one virtual impactor and remove the large particles in the other virtual impactor, resulting in the availability of a narrow slice of the distribution. These particles can be used as test, or calibration, aerosols or may be used for process control.

Masuda et al. (1979) used two “improved” virtual impactors (virtual impactors with clean sheath air at the outer walls and clean cores of air) for classifying paraffin aerosols, coal dust, slate powder, and asbestos fibers. Later, Masuda et al. (1987) used a single-stage rectangular virtual impactor to classify powders for the ceramic industry.

Chen et al. (1988) used two virtual impactors to generate narrow size ranges of raw oil shale, talc, and fly ash particles. They used two virtual impactors with cut sizes of 4.4 and 3.1  $\mu\text{m}$ , respectively, and classified the

powder into three size classes: (1) greater than the larger cut size (coarse), (2) smaller than the smaller cut size (fine), and (3) between the two cut sizes (middle).

Chen and Lundgren (1993) took a slightly different approach, using a virtual impactor to remove the small particles and a conventional impactor to remove the large particles. The virtual impactor used clean sheath air and interchangeable nozzles to vary the size of generated dust particles.

### Virtual Impactors with Respirable Particle Collection Efficiencies

Historically, virtual impactors have been designed to provide a sharp size cut between the particles in the major and minor flow fractions. However, if the virtual impactor is used as a respirable sampler, the separation characteristics must mimic a respirable curve such as that of the British Medical Research Council (BMRC), the American Conference of Industrial Hygienists (ACGIH), or the International Organization for Standardization (ISO). Olson (2000) developed such a virtual impactor to monitor a continuous coal-mining machine (see Figure 14). Olson achieved these respirable curves with the virtual impactor by adjusting (1) the minor-to-total flow ratio, (2) the inlet angle, (3) the nozzle throat length, and (4) the nozzle-to-collection probe distance.

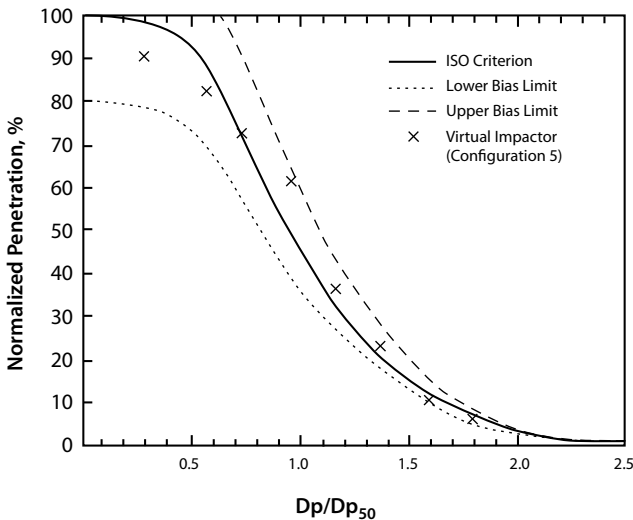

Figure 14. Respirable cut virtual impactor following the International Organization for Standardization (ISO) respirable criteria.

Source: Olson, 2000.



## Virtual Impactor as a Particle Concentrator

The feature that originally made the virtual impactor a popular sampler was its ability to separate particles into two size classes and keep both classifications airborne. This solved the problems of particle bounce and stage overloading that were common in conventional impactors. Thus, much of the early work in the field involved developing virtual impactors with sharp, well-defined separation characteristics between large and small particle fractions, as well as low internal particle losses. A key feature of virtual impactors is that the large particle fraction is concentrated in the minor flow, which is a small fraction of the total flow.

This feature has been important for several applications, including use of virtual impactors as concentrators for particle sizing instrumentation (Keskinen et al., 1987; Wu et al., 1989; Liebhaber et al., 1991), environmental particulate exposure chambers (Barr et al., 1983; Sioutas et al., 1994a, 1994b, 1995), and biological particle samplers.

The feature is particularly interesting in its application to exposure chambers. These virtual impactors use a rectangular slit design with a flow rate of 1,000 L/min and a cut size of 0.1  $\mu\text{m}$ . Figure 15 shows a schematic diagram of a slit virtual impactor (Sioutas et al., 1995).

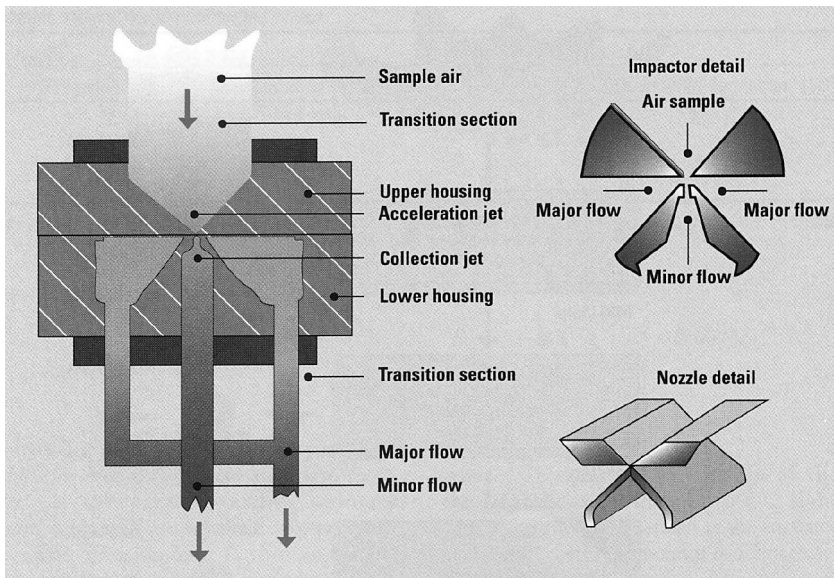

Figure 15. High-volume slit virtual impactor.

Source: Sioutas et al., 1995.

Another version of this type of concentrator, in which even smaller particles can be concentrated, first grows the particles in size by condensing water vapor on the particles and then passes the grown particles through a virtual impactor concentrator. After the particles are concentrated, the particles are dried, and the concentrated particles in their original state can be used for the exposure tests (Sioutas & Koutrakis, 1996).

The particle concentrating feature of virtual impactors has been important in sampling biological particles of the type used in biological warfare and terrorism activity. Here the purpose of the virtual impactor is to concentrate the threat particles into a small flow so that an appropriate instrument can analyze them. In these cases, it is not important that the cut size is well defined or that the particle concentration is known accurately, it is only important to know that some of the threat particles are present. Because the use of virtual impactors to sample aerosols from biological warfare and terrorism activity is a rather recent development and numerous variations of virtual impactors have been developed for this purpose, this chapter will not cover these virtual impactors.

## Conclusion

Conventional impactors were introduced in 1860 (Marple, 2004); thus, the virtual impactor, which was introduced in the 1960s, is a relatively new type of inertial size separator. Despite its relative newness, the virtual impactor has proved to be very useful as both a particle classifier and a particle concentrator. Conner (1966) originally developed the virtual impactor as an aerosol classifier. As such, the virtual impactor has been most valuable as the 2.5  $\mu\text{m}$  dichotomous sampler, having the ability to measure coarse ( $\text{PM}_{10-2.5}$ ) and fine particles ( $\text{PM}_{2.5}$ ). The advantage of using a virtual impactor rather than a conventional inertial impactor in this sampler is that there are not problems of particle overloading and particle bounce from the impaction plate. Biological samplers in which particles are concentrated in a small fraction of the flow have made extensive use of virtual impactors as particle concentrators, because they are suitable for a variety of analysis techniques.

Finally, the literature has disputed the origin of the virtual impactor. Many authors have credited the centripeter developed by Hounam and Sherwood (1965) as the first virtual impactor; however, other authors have credited the device developed by Connor (1966) as the first virtual impactor. Our analysis of these two papers shows that the device reported by Connor (1966) was

the original virtual impactor. Our analysis also shows that the centripeter is not a virtual impactor but is instead a series of particle-focusing lenses with centerline particle skimmers.

## References

- Baron, P. A., & Willeke, K. (Eds.). (2001). *Aerosol measurement: Principles, techniques, and applications* (2nd ed.). New York, NY: John Wiley & Sons.
- Barr, E. B., Hoover, M. D., Kanapilly, G. M., Yeh, H. C., & Rothenberg, S. J. (1983). Aerosol concentrator: Design, construction, calibration and use. *Aerosol Science and Technology*, 2, 437–442.
- Chein, H., & Lundgren, D. A. (1993). Virtual impactor with clean air core for the generation of aerosols with narrow size distributions. *Aerosol Science and Technology*, 18, 376–388.
- Chen, B. T., & Yeh, H. C. (1987). An improved virtual impactor: Design and performance. *Journal of Aerosol Science*, 18, 203–214.
- Chen, B. T., Yeh, H. C., & Rivero, M. A. (1988). Use of two virtual impactors in series as an aerosol generator. *Journal of Aerosol Science*, 16, 343–354.
- Conner, W. D. (1966). An inertial-type particle separator for collecting large samples. *Journal of the Air Pollution Control Association*, 16, 35.
- Dzubay, T. G., & Stevens, R. K. (1975). Ambient air analysis with dichotomous sampler and X-ray fluorescence. *Environmental Science & Technology*, 9, 663–668.
- Forney, L. J. (1976). Aerosol fractionator for large-scale sampling. *Review of Scientific Instruments*, 47, 1264–1269.
- Forney, L. J., Ravenhall, D. G., & Lee, S. S. (1982). Experimental and theoretical study of a two-dimensional virtual impactor. *Environmental Science & Technology*, 16, 492–497.
- Forney, L. J., Ravenhall, D. G., & Wins, D. S. (1978). Aerosol impactors: A study of a fluid jet impinging upon a void. *Journal of Applied Physics*, 49, 2339–2345.
- Han, R., & Moss, O. R. (1997). Flow visualization inside a water model virtual impactor. *Journal of Aerosol Science*, 28, 1005–1014.

- Hounam, R. F., & Sherwood, R. J. (1965). The cascade centripeter: A device for determining the concentration and size distribution of aerosols. *American Industrial Hygiene Journal*, 26, 122–131.
- Keskinen, J., Janka, K., & Lehtimäki, M. (1987). Virtual impactor as an accessory to optical particle counters. *Aerosol Science and Technology*, 6, 79–83.
- Koch, W., Dunkhorst, W., & Lodding, H. (1999). Design and performance of a new personal aerosol monitor. *Aerosol Science and Technology*, 31, 231–246.
- Li, S., & Lundgren, D. A. (1997). Effect of clean air core geometry on fine particle contamination and calibration of a virtual impactor. *Aerosol Science and Technology*, 27, 625–635.
- Liebhaber, F. B., Lehtimäki, M., & Willeke, K. (1991). Low-cost virtual impactor for large-particle amplification in optical particle counters. *Aerosol Science and Technology*, 15, 208–213.
- Liu, B. Y. H., Rubow, K. L., McMurry P. H., & Kotz, T. J. (1991, July 7). *Airborne particulate matter and spacecraft internal environments* (SAE Paper No. 911476). Paper presented at the International Conference on Environmental Systems, San Francisco, CA.
- Loo, B. W. (1981). *United States Patent No. 4,301,002*. Washington, DC: US Patent and Trademark Office.
- Loo, B. W., & Cork, C. C. (1988). Development of high efficiency virtual impactors. *Aerosol Science and Technology*, 9, 167–176.
- Loo, B. W., & Jaklevic, J. M. (1974). *An evaluation of the ERC virtual impactor* (Report to EPA and US Atomic Energy Commission, Contract No. W-7405-ENG-48). Berkeley, CA: Lawrence Berkeley Laboratory.
- Loo, B. W., & Jaklevic, J. M. (1979). *A second generation dichotomous sampler for large scale monitoring of airborne particulate matter* (Report to the US Department of Energy, Contract No. W-7405-ENG-48). Berkeley, CA: Lawrence Berkeley Laboratory.
- Loo, B. W., Jaklevic, J. M., & Goulding, F. S. (1976). Dichotomous virtual impactors for large scale monitoring of airborne particulate matter. In B. Y. H. Liu (Ed.), *Fine particles: Aerosol generation, measurement, sampling and analysis* (pp. 311–350). New York, NY: Academic Press.

- Marple, V. A. (2004). History of impactors—The first 110 years. *Aerosol Science and Technology*, 38, 247–292.
- Marple, V. A., & Chien, C. M. (1980). Virtual impactors: A theoretical study. *Environmental Science & Technology*, 14, 976–985.
- Marple, V. A., Liu, B. Y. H., & Burton, R. M. (1990). High-volume impactor for sampling fine and coarse particles. *Journal of the Air & Waste Management Association*, 40, 762–767.
- Marple, V. A., & Olson, B. A. (1995). A high volume PM<sub>10/2.5/1.0</sub> trichotomous sampler. *Particulate matter: Health and regulatory issues, VIP-49. Proceedings of an International Specialty Conference*. Pittsburgh, PA: Air and Waste Management Association.
- Marple, V. A., Rubow, K. L., & Olson, B. A. (1995). Diesel exhaust/mine dust personal aerosol: Sampler design, calibration and field evaluation. *Aerosol Science and Technology*, 22, 140–150.
- Masuda, H., Hochrainer, D., & Stober, W. (1979). An improved virtual impactor for particle classification and generation of test aerosols with narrow size distributions. *Journal of Aerosol Science*, 10, 275–287.
- Masuda, H., Motooka, T., Tanabe, T., Hong, G. H., & Watanabe, K. (1987). Size classification of industrial sub-micron powder by a virtual impactor. *Powder Technology*, 50, 155–161.
- McFarland, A. R., Ortiz, C. A., & Bertch, R. W., Jr. (1978). Particle collection characteristics of a single-stage dichotomous sampler. *Environmental Science & Technology*, 12, 679–682.
- Novick, V. J., & Alvarez, J. L. (1987). Design of a multistage virtual impactor. *Aerosol Science and Technology*, 6, 63–70.
- Olson, B. A. (2000). *Simulation of respirable mass sampling criteria using single round-nozzle virtual impactor technology* (Doctoral dissertation). University of Minnesota, Minneapolis.
- Ravenhall, D. G., Forney, L. J., & Jazayeri, M. (1978). Aerosol sizing with a slotted virtual impactor. *Journal of Colloid and Interface Science*, 1, 108–117.

- Rubow, K. L., Cantrell, B. K., & Marple, V. A. (1990). Measurement of coal dust and diesel exhaust aerosols in underground mines. In *Proceedings of the 7th International Conference on the Pneumoconiosis, August 23-26, 1988, Pittsburgh, PA* (NIOSH Publication No. 90-108, pp. 645-650). Atlanta, GA: US Department of Health and Human Services.
- Sioutas, C., & Koutrakis, P. (1996). Inertial separation of ultrafine particles using a condensational growth virtual impaction system. *Aerosol Science and Technology*, 25, 424-436.
- Sioutas, C., Koutrakis, P., & Burton, R. M. (1994b). Development of a low cutpoint slit virtual impactor for sampling ambient fine particles. *Aerosol Science and Technology*, 25, 1321-1330.
- Sioutas, C., Koutrakis, P., & Burton, R. M. (1995). A technique to expose animals to concentrated fine ambient aerosols. *Environmental Health Perspectives*, 103, 172-177.
- Sioutas, C., Koutrakis, P., & Olson, B. A. (1994a). Development and evaluation of a low cutpoint virtual impactor. *Aerosol Science and Technology*, 21, 223-235.
- Wu, J. J., Cooper, D. W., & Miller, R. J. (1989). Virtual impactor aerosol concentrator for cleanroom monitoring. *Journal of Environmental Sciences*, 5, 52-56.
- Xu, X. (1991). *A study of virtual impactor* (Doctoral dissertation). University of Minnesota, Minneapolis.