

# Won-Door Corporation

<b>FIREGUARD 20, 60, 90, 180; TR .....</b>	<b>1</b>
<b>FIRE DOOR SELECTION GUIDE .....</b>	<b>1</b>
<b>SPECIFICATIONS: FIREGUARD 20, 60, 90, 180; TR.....</b>	<b>3</b>
<b>GUIDELINES FOR TEMPERATURE RISE DOORS .....</b>	<b>10</b>
<b>STRAIGHT DOOR – HEAD DETAIL PLYWOOD HEADER .....</b>	<b>11</b>
<b>STRAIGHT DOOR – HEAD DETAIL UNITIZED TRACK SYSTEM.....</b>	<b>12</b>
<b>STRAIGHT DOOR – HEAD DETAIL STEEL PAN HEADER .....</b>	<b>13</b>
<b>STRAIGHT DOOR – PLAN VIEW SINGLE PARTING.....</b>	<b>14</b>
<b>STRAIGHT DOOR – PLAN VIEW BI-PARTING .....</b>	<b>15</b>
<b>STRAIGHT DOOR – ELEVATION SIDE VIEW .....</b>	<b>16</b>
<b>STRAIGHT DOOR – ELEVATION FRONT VIEW .....</b>	<b>17</b>
<b>POCKET DEPTH CHART INSTRUCTIONS.....</b>	<b>18</b>
<b>STRAIGHT DOOR – POCKET DEPTH CALCULATION CHART .....</b>	<b>19</b>
<b>CURVED DOOR – HEAD DETAIL .....</b>	<b>20</b>
<b>CURVED DOOR – PLAN VIEW SINGLE PARTING.....</b>	<b>21</b>
<b>CURVED DOOR – PLAN VIEW BI-PARTING .....</b>	<b>22</b>
<b>CURVED DOOR GUIDELINES.....</b>	<b>23</b>
<b>CURVED DOOR – ELEVATION FRONT VIEW .....</b>	<b>24</b>
<b>POCKET DEPTH CHART INSTRUCTIONS.....</b>	<b>25</b>
<b>CURVED DOOR – POCKET DEPTH CALCULATION CHART .....</b>	<b>26</b>
<b>POCKET DEPTH CHART INSTRUCTIONS.....</b>	<b>27</b>
<b>POCKET DEPTH CALCULATION CHART TR.....</b>	<b>28</b>
<b>POCKET COVER DOOR GUIDELINES.....</b>	<b>29</b>
<b>POCKET COVER DOOR DETAIL .....</b>	<b>30</b>
<b>POCKET MOUNTED MOTOR OPERATOR ELECTRICAL DIAGRAM .....</b>	<b>31</b>
<b>LARGE DOOR MOTOR OPERATOR ASSEMBLY WIRING DIAGRAM .....</b>	<b>32</b>
<b>OPTIONAL KEY SWITCH.....</b>	<b>33</b>
<b>CCOM ROCKER SWITCH .....</b>	<b>34</b>
<b>OPTIONAL VISION PANEL .....</b>	<b>35</b>
<b>OPTIONAL INDIVIDUAL LCD DOOR STATUS DISPLAY .....</b>	<b>36</b>
<b>OPTIONAL MULTIPLE EXIT DEVICE DETAIL .....</b>	<b>37</b>



# Won-Door Corporation

<b>FIREGUARD STOCK DOOR .....</b>	<b>39</b>
<b>SPECIFICATIONS: FIREGUARD STOCK DOOR.....</b>	<b>39</b>
<b>HEAD DETAIL .....</b>	<b>45</b>
<b>PLAN VIEW - SLIM DRIVE.....</b>	<b>46</b>
<b>ELEVATION SIDE VIEW SLIM DRIVE.....</b>	<b>47</b>
<b>ELEVATION FRONT VIEW .....</b>	<b>48</b>
<b>SLIM DRIVE MOTOR OPERATOR ELECTRICAL DIAGRAM.....</b>	<b>49</b>
<b>CCOM ROCKER SWITCH .....</b>	<b>50</b>
<b>FIREGUARD CC.....</b>	<b>51</b>
<b>GUIDELINES FOR FIREGUARD CROSS CORRIDOR (CC).....</b>	<b>51</b>
<b>SPECIFICATIONS: FIREGUARD CROSS CORRIDOR .....</b>	<b>53</b>
<b>HEAD DETAIL .....</b>	<b>59</b>
<b>PLAN VIEW - SLIM DRIVE.....</b>	<b>60</b>
<b>ELEVATION SIDE VIEW SLIM DRIVE.....</b>	<b>61</b>
<b>ELEVATION FRONT VIEW .....</b>	<b>62</b>
<b>POCKET DEPTH CHART INSTRUCTIONS.....</b>	<b>63</b>
<b>POCKET DEPTH CALCULATION CHART .....</b>	<b>64</b>
<b>SLIM DRIVE MOTOR OPERATOR ELECTRICAL DIAGRAM.....</b>	<b>65</b>
<b>OPTIONAL KEY SWITCH.....</b>	<b>66</b>
<b>CCOM ROCKER SWITCH .....</b>	<b>67</b>
<b>OPTIONAL VISION PANEL .....</b>	<b>68</b>



# Won-Door Corporation

<b>FIREGUARD CROSS CORRIDOR CS.....</b>	<b>69</b>
GUIDELINES FOR FIREGUARD COMPRESSED STACK (CS) .....	69
SPECIFICATIONS: FIREGUARD CROSS CORRIDOR CS .....	71
HEAD DETAIL .....	77
PLAN VIEW - 12'-0" AND LESS OPENING WIDTH.....	78
PLAN VIEW - ABOVE 12'-0" OPENING WIDTH .....	79
ELEVATION SIDE VIEW 12'-0" AND LESS OPENING WIDTH .....	80
ELEVATION SIDE VIEW ABOVE 12'-0" OPENING WIDTH .....	81
ELEVATION FRONT VIEW .....	82
POCKET DEPTH CHART INSTRUCTIONS.....	83
POCKET DEPTH CALCULATION CHART .....	84
SLIM DRIVE MOTOR OPERATOR ELECTRICAL DIAGRAM.....	85
POCKET MOUNTED MOTOR OPERATOR ELECTRICAL DIAGRAM .....	86
OPTIONAL KEY SWITCH.....	87
CCOM ROCKER SWITCH .....	88
OPTIONAL VISION PANEL .....	89
OPTIONAL MULTIPLE EXIT DEVICE DETAIL .....	90
<b>FIREGUARD MOVEABLE FIREWALL .....</b>	<b>91</b>
GUIDELINES FOR FIREGUARD MOVEABLE FIRE WALL.....	91
SPECIFICATIONS: FIREGUARD MFW .....	93
MFW – HEAD DETAIL .....	99
MFW – PLAN VIEW .....	100
MFW – ELEVATION SIDE VIEW .....	101
MFW – ELEVATION FRONT VIEW .....	102
POCKET DEPTH CHART INSTRUCTIONS.....	103
POCKET DEPTH CALCULATION CHART .....	104
POCKET COVER DOOR GUIDELINES.....	105
POCKET COVER DOOR DETAILS .....	106
POCKET MOUNTED MOTOR OPERATOR ELECTRICAL DIAGRAM .....	107
OPTIONAL KEY SWITCH.....	108



# Won-Door Corporation

<b>DURASOUND SOUND BARRIER (STC 48)</b> .....	<b>109</b>
SPECIFICATIONS: DURASOUND .....	109
STRAIGHT DOOR – HEAD DETAIL .....	113
STRAIGHT DOOR – HEAD DETAIL .....	114
STRAIGHT DOOR – HEAD DETAIL .....	115
CURVED DOOR – HEAD DETAIL .....	116
PLAN VIEW – MANUAL OPERATION .....	117
PLAN VIEW – MOTORIZED OPERATION.....	118
ELEVATION – SIDE VIEW.....	119
ELEVATION – SIDE VIEW.....	120
ELEVATION – FRONT VIEW .....	121
DURASOUND – POCKET DEPTH CALCULATION CHART MANUALLY OPERATED .....	122
DURASOUND – POCKET DEPTH CALCULATION CHART MOTOR OPERATED .....	123
CURVED DOOR GUIDELINES.....	124
CURVED DOOR GUIDELINES.....	125
CONFIGURATION OPTIONS MULTI-MEETING LEAD POSTS.....	126
MOTOR OPERATOR WIRING DIAGRAM .....	127
OPTIONAL KEY SWITCH.....	128
<b>DURASOUND XL SOUND BARRIER (STC 48)</b> .....	<b>129</b>
SPECIFICATIONS: DURASOUND XL.....	129
STRAIGHT DOOR – HEAD DETAIL .....	133
STRAIGHT/CURVED – MOTORIZED DOOR HEAD DETAIL.....	134
PLAN VIEW.....	135
ELEVATION – SIDE VIEW MANUAL OPERATION.....	136
ELEVATION – SIDE VIEW MOTORIZED OPERATION .....	137
ELEVATION – FRONT VIEW .....	138
DURASOUND XL – POCKET DEPTH CALCULATION CHART MANUALLY OPERATED ....	139
DURASOUND XL – POCKET DEPTH CALCULATION CHART MOTOR OPERATED.....	140
MOTOR OPERATOR WIRING DIAGRAM .....	141
OPTIONAL KEY SWITCH.....	142



# Won-Door FireGuard

## FIRE DOOR SELECTION GUIDE

This guide will assist the specifier in selecting the most appropriate assembly and related options based on:

1. Fire rating required.
2. Special requirements for access control/security.

### FIRE RATINGS:

1. Won-Door FireGuard is listed as a fire-rated door (NFPA 252 and UL10B) with ratings up to 3 hours.

<u>Door Model</u>	<u>Fire Rating</u>
Won-Door FireGuard 20	20 Minutes
Won-Door FireGuard 60	1 Hour
Won-Door FireGuard 90	1 1/2 Hours
Won-Door FireGuard 180	3 Hours

2. Won-Door FireGuard is also listed as a 450° temperature rise door (NFPA 252) with a 1 1/2 hour rating for use in stairwell enclosure applications

<u>Door Model</u>	<u>Fire Rating</u>
Won-Door FireGuard 90TR	1 1/2 Hour Temperature Rise

3. Won-Door FireGuard is also listed as a moveable fire wall (ASTM E-119) in straight, single parting configurations.

<u>Door Model</u>	<u>Fire Rating</u>
Won-Door FireGuard MFWI	1 Hour
Won-Door FireGuard MFWII	2 Hours

### SPECIAL REQUIREMENTS (OPTIONAL):

1. Exit Devices may be specified at multiple locations along the door assembly to allow exiting from a space where a single exit device would not be sufficient. (see details on page 37)
2. Vision Panels may be specified to meet code requirements for smoke barriers. (see details on page 35)
3. Access Control Options. Where required, the Won-Door FireGuard assembly can be equipped to provide two levels of access control. (*Note: Access Control is disabled when the door is in fire mode.*)

#### a. SteelCurtain Level 1 Access Control – Disabled Exit Devices

When the door is in the normal supervisory mode, the door's exit devices are programmed to be inactive (it is active in emergency mode only). In addition, the closing system will seek the closed position. If an attempt is made to force the door off its closed limit, it immediately re-closes and sounds an alarm. The alarm can sound locally or remotely. When the door re-closes, the clutch engages for approximately 5 minutes to resist further attempts to force it open. A key switch or other access device is required to open/close the door, therefore specifiers must determine the type and location of the device(s) and specify the required boxes, conduit and wiring in the electrical section of the specification. (See pages 31, 32)

For increased security, the standard sliding jamb and "quick release" jamb stops can be replaced with a heavy-gauge steel sliding jamb and rigid Z-shaped fixed jamb stops. An additional 1" of pocket depth is required.

#### b. SteelCurtain Level 2 Access Control – Electromagnetic Locking Device

An electromagnetic locking clutch is added to the closing system and provides 400 to 500 pounds of resistance to opening. A key switch or other access device is required to open/close the door, therefore specifiers must determine the type and location of the device(s) and specify the required boxes, conduit and wiring in the electrical section of the specification. (See pages 31, 32)

### USING OTHER TYPES OF ACCESS DEVICES (OPTIONAL)

In the access control applications, other types of operating devices can be added including numeric keypads, push button and infrared operating devices, providing they are capable of receiving a low voltage signal via stranded 18-gauge wire in conduit to the Won-Door automatic closing system control box. Additional operating device contacts can be added as required. These access devices should be defined, provided, and installed under the respective specification section.



# Won-Door FireGuard

This page intentionally left blank.



# Won-Door FireGuard

## SECTION 08 35 13.23 – ACCORDION FOLDING FIRE DOORS

### PART 1 – GENERAL

#### 1.01 SUMMARY OF WORK

- A. Division 0 and 1, as indexed, apply to this section.
- B. Furnish and install all horizontal sliding, accordion folding fire doors shown on the drawings and specified herein.

#### 1.02 RELATED SECTIONS

- A. All headers, support structures, surrounding insulation, jambs, storage pockets, pocket doors, access doors, blocking and trim shall be furnished and installed by other sections. *(NOTE 1: Plywood headers may be included as an option. See Section 2.03 E. The plywood header option does not include support structures, fire protection of support structures, surrounding insulation, jambs, storage pockets, pocket doors, access doors, blocking, drywall work or trim. NOTE 2: Unitized track for straight doors in size up to 30'-0" x 10'-0" may be included as an option. See Section 2.03 F. The unitized track option does not require a plywood header. The unitized track option does not include support structures, fire protection of support structures, surrounding insulation, jambs, storage pockets, pocket doors, access doors, blocking, drywall work or trim.)*
- B. All electrical wire, wiring, conduit and electrical boxes shall be furnished and installed by electrical section including connections to smoke detectors and building fire alarm panels.
- C. Drilling/placement of anchorage points into pre or post tensioned decks, welding/punching/drilling steel members and all drywall work.
- D. **OPTION:** All track, soffit, chain guide and wall mounted striker posts shall be painted by Section 09900. Color shall be selected by the architect.
- E. **OPTION:** *If Section 2.03 I, Individual LCD Door Status Display, is selected as an option, the following paragraph should be included:* Wiring for Individual LCD Door Status Display at fire door-One (1) USOC RJ14-6POS 4 wire jack shall be supplied at the back of the storage pocket and shall be tied to the 4 square junction box adjacent to the door with CAT 5 twisted 2 pair cable. The junction box, RJ14 jack and wire shall be furnished and installed by the electrical section. Termination to the Individual LCD Door Status Display panel shall be by punch down block and shall be by the electrical section as per the manufacturer's instructions.

#### 1.03 QUALITY ASSURANCE

- A. Installation shall be performed by factory trained and certified installers with a minimum of three years experience installing electrically operated accordion folding fire doors.
- B. Fire doors shall be listed by Underwriters Laboratories for ratings as indicated, when tested in accordance with the requirements of UL 10B and NFPA 252.
- C. Automatic closing system shall be listed by Underwriters Laboratories in accordance with the requirements of UL 864 and be listed for use with assembly in compliance with NFPA 80, Chapter 9. Motor operator shall be rated for continuous use with unlimited cycle duty.
- D. Fire doors used for smoke and draft control shall bear the "S" mark on the fire door label and shall have an air leakage of less than 3 ft<sup>3</sup>/ft<sup>2</sup> at 0.1 inch of water column pressure when tested in accordance with UL 1784 with an artificial bottom seal.



# Won-Door FireGuard

- E. Fire doors used at the point of access to an elevator shall bear the “SE” mark on the fire door label and shall have an air leakage of less than 3 ft<sup>3</sup>/ft<sup>2</sup> at 0.1 inch of water column pressure when tested in accordance with UL 1784 without an artificial bottom seal.
- F. Fire Door shall be capable of resisting an air pressure differential up to 0.05 inches of water column. Air pressure resistance to 0.1 inches of water column available. (See Section 2.03 J)

## 1.04 SUBMITTALS

- A. Refer to Section 01 30 00 – Administrative requirements for shop drawings and submittals.
- B. Product Data: Provide manufacturer’s technical literature; include UL listing data.
- C. Shop Drawings: Indicate construction and installation details and dimensions, including layout, electrical requirements, required stacking depth, height of header above finished floor, and requirements for anchorage and support of each door.
- D. Operation and Maintenance Data: Operating manual, troubleshooting and repair methods, and wiring diagrams shall be provided as part of project close out procedure.

## 1.05 DELIVERY, STORAGE, AND HANDLING

- A. Deliver to the job site in manufacturer's original, unopened package.

## 1.06 COORDINATION BY GENERAL CONTRACTOR

- A. Coordinate with the following:
  - 1. Fire Alarm System.
  - 2. Electrical.
  - 3. Panel pocket doors and wood veneer paneling (if applicable).
  - 4. Floor and ceiling finish.
- B. Assure accurate installation of header, jamb, and trim. Provide “As-Built” dimensions for opening and storage pocket. Supervise unloading and handling of materials.
- C. Permanent power shall be in-place and ready for final connection when fire doors are erected. Assure access to and proper clearance for motor operators.
- D. After testing the fire alarm system, automatic-closing fire doors shall be re-set to the original position.
- E. Store boxes flat (not more than three high) in a dry area and protect from elements that may damage materials. Replace damaged materials at no cost to the owner.

## 1.07 WARRANTY

- A. Materials and installation shall be warranted against defects in workmanship for a period of one (1) year from the date of substantial completion.

## PART 2 – PRODUCTS

### 2.01 MANUFACTURER AND MODEL

- A. Horizontal sliding accordion folding fire doors shall be Won-Door FireGuard model FG\_\_(select one: 20, 60, 90, or 180 - number designates minutes of fire rating) as manufactured by Won-Door Corporation, Salt Lake City, Utah. *(Note: Add suffix “S” for smoke and draft OR suffix “SE” if door is used at the point of access to an elevator OR suffix*





# Won-Door FireGuard

*“TR” for temperature rise of 450° F at 30 minutes. When specifying “TR” doors, contact the manufacturer for pocket depths, hanging weight and size limitations.)*

- B. Products of other manufacturers demonstrating complete compliance with each of the fire rating and performance criteria of the product specified will be considered for approval. Written requests for substitutions will be considered by the architect up to ten days prior to the bid date.
- C. **OPTION:** No substitutions allowed.

## 2.02 ACCORDION FIRE DOORS - GENERAL

- A. Provide power operated self-closing fire doors of configurations indicated on the drawings.
  - 1. Fire rating as required.
- B. Fire Rating: Fire Doors shall be listed by Underwriters Laboratory as special purpose fire doors having a [select one: 20, 60, 90, or 180] minute fire-resistive rating in accordance with the requirements of UL 10B and NFPA 252.
- C. Closing and Opening Operation: Automatic Closing System including motor operator and releasing devices shall be a Microprocessor-based system rated to UL864 (Releasing Device Control Unit) and shall commence closing upon activation by fire alarm system and/or by low battery charge.
  - 1. Obstruction Detection: Contact with an obstruction shall cause the door to stop, reverse enough to remove pressure on the leading edge, pause, and then re-close when in an alarm condition.
  - 2. While the door is opening under motor power, constant pressure to the leading edge in the direction of opening shall cause the door to continue to open until the leading edge is released. This is termed motor-assisted opening.
  - 3. Constant pressure to the leading edge while not under motor power shall prevent motor operation and allow the door to be opened manually.
- D. Exit Device Operation: Provide fire exit devices on both sides of door.
  - 1. In emergency mode, a slight pressure on the device will cause the door to open a minimum of 32 inches, pause for 3 seconds, and then automatically close.
  - 2. The open distance shall be field programmable, up to the entire opening width, if the local authority requires an opening larger than 32 inches.
  - 3. The pause before re-close shall be field programmable, up to 30 seconds, if the local authority requires a longer pause time.
  - 4. The exit device shall have the ability when not in the emergency (fire) mode to be used to open the door and move it back into the storage pocket.
  - 5. **OPTION:** *If Section 2.03 M or N, Access Control, is selected as an option, the following paragraph should be included:* The exit devices shall be field programmable to provide access control. When programmed, the exit device shall not respond when pressed until activated by signal from smoke detector or fire alarm.

## 2.03 COMPONENTS

- A. Door Construction: Two parallel, accordion-type walls of panels independently suspended with no floor tracks, pantographs, or interconnections except at the lead-post.



# Won-Door FireGuard

1. Panels shall be formed of 24-gauge enamel coated steel V-grooved for strength and resilience. Panels shall be connected by full height 24-gauge enamel coated steel hinges. Panels shall be modular in design and capable of in-place repair-ability.
  2. Perimeter Seals: shall consist of continuous extruded vinyl sweeps attached to the top and bottom of the fire door to form a smoke and draft seal.
  3. Hanging weight shall be 5.5 pounds per square foot (6.5 lbs. per sq. ft. for TR models) when extended across the opening.
  4. Finish: All steel parts factory applied enamel.
  5. Color: Manufacturer's standard platinum.
- B. Suspension System: Two tracks, on 8 inch centers, attached to overhead structural support.
1. Tracks: 14 gauge cold rolled steel or .125 aluminum.
  2. Panel hangers: Panels supported from a steel hanger pin and a ball bearing roller.
  3. Lead Post hangers: 8 wheel ball bearing trolley.
- C. Power Supply: 12-volt/24-volt maintenance-free DC battery, automatically maintained at capacity by continuous charger, 120 V AC.
- D. Automatic Closing System shall be listed to UL864 including capability to send and receive signals from the Fire Control Panel and shall consist of the following:
1. Microprocessor based Electronic Control box with these features:
    - a. Ability to monitor dual power sources continually for peak performance including:
      - 1) Detect a missing battery, bad battery, or low battery condition.
      - 2) Detect if the charging circuit is bad.
      - 3) Detect fuse failures.
      - 4) Detect high or low AC conditions.
    - b. Ability to monitor the health of the drive train.
    - c. Ability to monitor inputs including: Sticky door block, exit devices, and patron devices.
    - d. Ability to run a "watch dog" monitoring circuit which will force a software restart in the event the software hangs, including the ability to track the number of resets that occur for diagnostic purposes.
    - e. Ability to withstand voltages up to 120 volts AC on the fire alarm input circuit without damage including the ability to indicate that the alarm circuit has not been wired as a dry contact, "no voltage" circuit when errant voltages are applied to the circuit.
    - f. Ability to communicate with other microprocessors in the assembly via an internal buss system.
    - g. Ability to indicate trouble or supervised information both locally and at a remote location.



# Won-Door FireGuard

2. Motor Operator Assembly including: A DC gear-motor, drive sprocket, clutch, and position sensors. The motor shall drive the fire door by means of a chain attached to a stabilizer bar.
  3. If a key switch (**NOTE: Section 2.03 H**) is NOT used, a door control momentary rocker switch shall be mounted on one side of the door near the lead post and shall function as follows:
    - a. Pressing the upper portion of the switch shall close the door and/or clear fault conditions.
    - b. Pressing the lower portion of the switch shall open the door and/or temporarily mute the local horn.
    - c. For doors using wall mounted key switches, Section 2.03 H, a color coordinated cover plate shall be provided to fill the hole left when the rocker switch is removed.
  4. Leading Edge Obstruction Detector: shall be pressure sensitive such that each contact with an obstruction shall cause the door to stop, reverse enough to remove pressure on the leading edge, pause, and then re-close when in an alarm condition. The leading edge obstruction detector shall be fully functional at all times, including during the initial closing cycle.
  5. Exit Devices will be located on both sides of the fire door.
  6. Doors installed at the point of access to an elevator include the following extras: anti-sway brackets every five feet or less across the opening and foil tape between the panels and the smoke liner.
- E. **OPTION:** Plywood headers shall be furnished and installed under this section. Installation is contingent on the structural support being less than five (5) feet above the plywood header assembly. Materials included are the plywood, threaded rods, and mechanical attachment hardware only. Drilling/placement of anchorage points into pre- or post-tensioned decks is by others. Welding/punching/drilling of steel members is by others. All drywall work is by others. Field dimensions are included.
- F. **OPTION:** Unitized track shall be furnished and installed under this section for straight doors up to 30'-0" x 10'-0". No header required. Installation is contingent on the structural support being less than five (5) feet above the track assembly. Materials included are unitized track, threaded rods and mechanical attachment hardware only. Drilling/placement of anchorage points into pre- or post-tensioned decks is by others. Welding/punching/drilling of steel members is by others. All drywall work is by others.
- G. **OPTION:** Door shall include a Vision Panel consisting of a frame and clear glass assembly with listings from Underwriters Laboratory up to 1 1/2 hours. (*Note: required only in smoke barriers in Group I occupancies.*)
- H. **OPTION:** A Key switch module shall be provided, located as directed by the Architect. (*Note: required for doors with Large Door Motor Operators and doors equipped with Access Control devices.*)
- I. **OPTION:** An Individual LCD Door Status Display panel shall be provided adjacent to the door to indicate in the English language the status of the door, i.e. door position and trouble conditions. It shall have a port that allows easy access to a diagnostic tool for the purposes of field programming the door to customized settings.



# Won-Door FireGuard

- J. **OPTION:** Air Pressure Resistance. The door shall be capable of resisting an air pressure differential between 0.05 - 0.15 inches water column and maintain normal operation. For air pressure differentials of 0.05 to 0.1, anti-sway brackets shall be placed interior to the door approximately every five (5) feet or less and lead post outriggers shall be provided; for air pressure differentials of 0.1 to 0.15, a self-leveling lead post assembly shall provide motorized tracking of the leading edge of the door to assure proper closure. (*NOTE: edit above selections depending on level of pressure differential expected*)
- K. **OPTION:** An infrared light beam shall be provided on non-curved doors to monitor the opening path. In the event that an object is placed in the path of the door for more than 4 minutes, the beam shall cause the door to sound an alarm indicating a path obstruction.
- L. **OPTION:** Acoustic Insulation: Interior surfaces of both walls shall be completely covered with a continuous blanket of 2 lb. density foil-backed fiberglass fastened in place with steel spring-clips. (*Note: When specifying insulated doors, contact the manufacturer for pocket depths, hanging weight and size limitations.*)
- M. **OPTION:** Level 1 Access Control: The Exit Devices shall not respond when pressed until activated/over-ridden by signal from smoke detector or fire alarm. A rigid jamb stop and key switch shall be provided for authorized operation of the door assembly. A signal from the smoke detector or fire alarm will automatically override the access control feature. (*Note: at least one key-switch required.*)
- N. **OPTION:** Level 2 Access Control. The door(s) shall be programmable such that when in the access control mode, the exit devices shall not respond when pressed until activated/over-ridden by a signal from the smoke detector or fire alarm. Door(s) shall also include a steel sliding jamb, rigid jamb stops, and 10 gauge steel vertical reinforcement to the lead post. An electromagnetic locking brake shall be added to the motor operator assembly to provide 400-500 pounds of resistance to manual opening. Key switch/alarm module shall be provided to open/close/reset the doors. (*Note: Level 1 and Level 2 Access Control options are independent systems and may not be specified in conjunction with each other*)

## 2.04 RELATED CONSTRUCTION

- A. Track Support Construction: Provide supports attached to structure and mounting surface for tracks; comply with door manufacturer's instructions and recommendations. Headers, if furnished & installed by the general contractor or other sections, shall be parallel with the finished floor within +/- 1/8" tolerance over the entire length of the opening.
- B. Pocket Construction: Provide pocket for concealment of accordion folding fire door when open; comply with door manufacturer's instructions and recommendations to ensure pocket and soffit are built to the dimensions specified, plumb and level.
- C. Pocket Door: Maintain full pocket clear width when pocket door is open.
- D. Striker Recess: mount 16 gauge steel striker in wall recess deep enough to prevent striker from protruding beyond face of wall; construct recess to maintain fire rating of wall.

## PART 3 – EXECUTION

### 3.01 EXAMINATION

- A. Verify that adjacent construction is suitable for installation of door.
- B. Verify that electrical utilities have been installed and are accessible.
- C. Verify that door opening is plumb and header is level and of correct dimensions.



# Won-Door FireGuard

D. Notify Architect of any unacceptable conditions or varying dimensions.

## 3.02 INSTALLATION

A. Install fire doors in accordance with manufacturer's instructions, shop drawings, and NFPA 80.

B. Install fire doors plumb and level.

C. Installation shall be performed by factory trained and certified installers with a minimum of three years experience installing electrically operated accordion folding fire doors.

## 3.03 ADJUSTING

A. Adjust door installation to provide uniform clearances and smooth, quiet, non-binding operation.

B. Test that all operations are functional and meet the requirements of local codes.

## 3.04 CLEANING

A. Clean surfaces using manufacturer's recommended means and methods.

## 3.05 PROTECTION

A. Protect installed work from damage.

## 3.06 STORAGE OF WASTE AND RECYCLING

A. Store and recycle waste in accordance with Section 01 74 19 Construction Waste Management and Disposal.

Copyright © 2013 by Won-Door Corporation, all rights reserved.  
END OF SECTION



# Won-Door FireGuard

## GUIDELINES FOR TEMPERATURE RISE DOORS

**Won-Door FireGuard TR** (temperature rise) doors have been tested in accordance with the ASTM E-252 standard for fire doors for 90 minutes and have qualified for the “temperature rise” label because the monitored back-face (unexposed side) temperature did not exceed 450° during the first 30 minutes of the test.

1 1/2 hour fire-rated temperature rise doors are required in all current model building codes as opening protectives for door penetrations in non-sprinklered exit enclosures.

This section includes a Specification and a Pocket Depth Calculation chart that apply specifically to Won-Door FireGuard TR. All TR model head details, plan views, elevations, pocket details, pocket cover door details, wiring diagrams and accessories (except for the vision panel which is not allowed in TR doors) are identical to other Won-Door FireGuard door models. Refer to the details in Section 2 of this design manual entitled “Won-Door FireGuard” (pages 11 through 37).



# Won-Door FireGuard

## STRAIGHT DOOR – HEAD DETAIL PLYWOOD HEADER

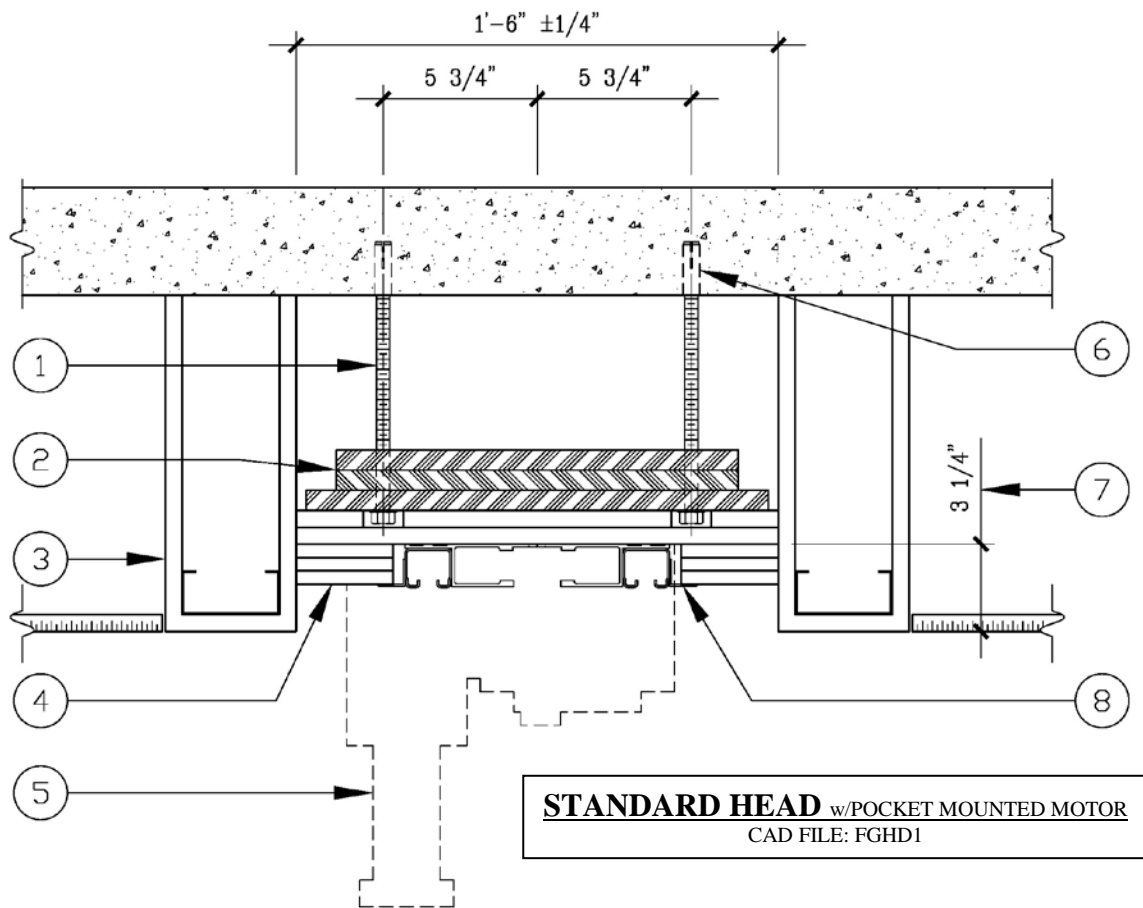

This detail to be used for doors greater than 30'-0" single parting, 60'-0" bi-parting, greater than 12'-0" tall.

1. 1/2" dia. threaded rod with nuts and washers by others. (18" O.C. in opening, 12" O.C. in stack area.)
2. 1 layer 3/4" x 17 1/4" continuous plywood and 2 layers 3/4" x 15" continuous plywood. Stagger joints, glue and screw together @24" O.C. with 2 #7 x 1 5/8" screws. [OR] 1/2" X 18" steel plate.
3. Provide rated construction on each side corresponding to rating required for opening by others. (Note: 1 hour condition shown. To view additional rated conditions, visit our website @ [www.wondoors.com](http://www.wondoors.com))
4. Two layers 5/8" x 18" x continuous type "X" gypsum board and three layers 1/2" x 3 5/8" type "X" gypsum board terminating 12" into the pocket. All gypsum to be furnished, installed, finished, and field painted by others.
5. Motor operator unit. (Mounted at back of pocket.) (See page 16)
6. Structural support or anchorage by others. Structural support is not limited to concrete deck.
7. Minimum dimension required to meet U.L. compliance. The dimension may be increased to further recess the head condition if required.
8. L-shaped trim piece with pre-finished white color to match track by Won-Door. (Provides transition from track to gypsum soffit.)



Brackets [ ] indicate specifier's option



# Won-Door FireGuard

## STRAIGHT DOOR – HEAD DETAIL UNITIZED TRACK SYSTEM

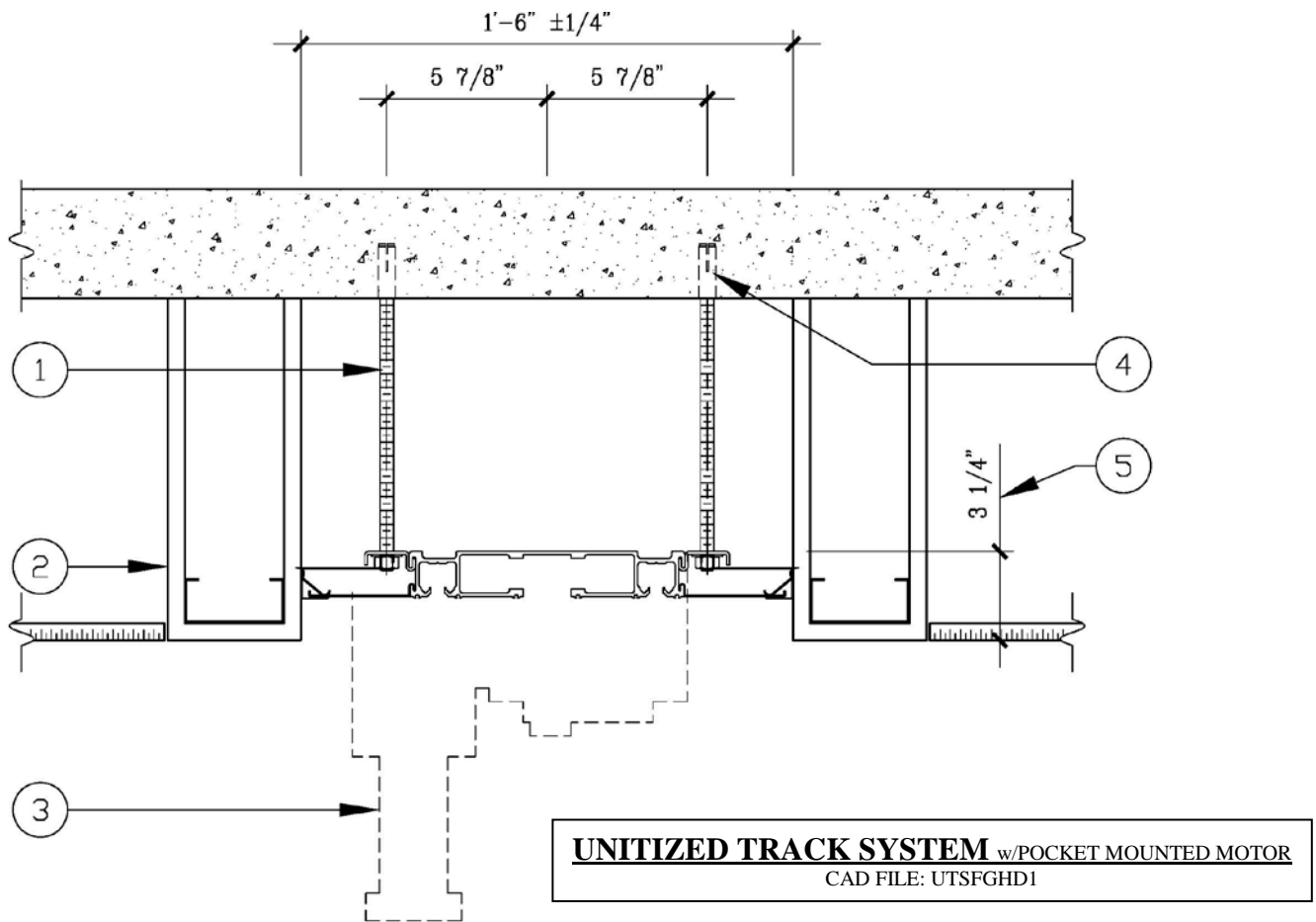

This detail to be used for 20, 60, 90 minute rated doors less than 30'-0" single parting, 60'-0" bi-parting, less than 12'-0" tall.

1. 1/2" threaded rods, Unitized Track System by Won-Door.
2. Provide rated construction on each side corresponding to rating required for opening by others. (Note: 1 hour condition shown. To view additional rated conditions, visit our website @ [www.wondoors.com](http://www.wondoors.com))
3. Motor operator unit. (Mounted at back of pocket.) (See page 16)
4. Structural support or anchorage by others. Structural support is not limited to concrete deck.
5. Minimum dimension required to meet U.L. compliance. The dimension may be increased to further recess the head condition if required.



The Unitized Track System may be specified for straight doors less than 30'-0" wide and 10'-0" tall.





# Won-Door FireGuard

## STRAIGHT DOOR – HEAD DETAIL STEEL PAN HEADER

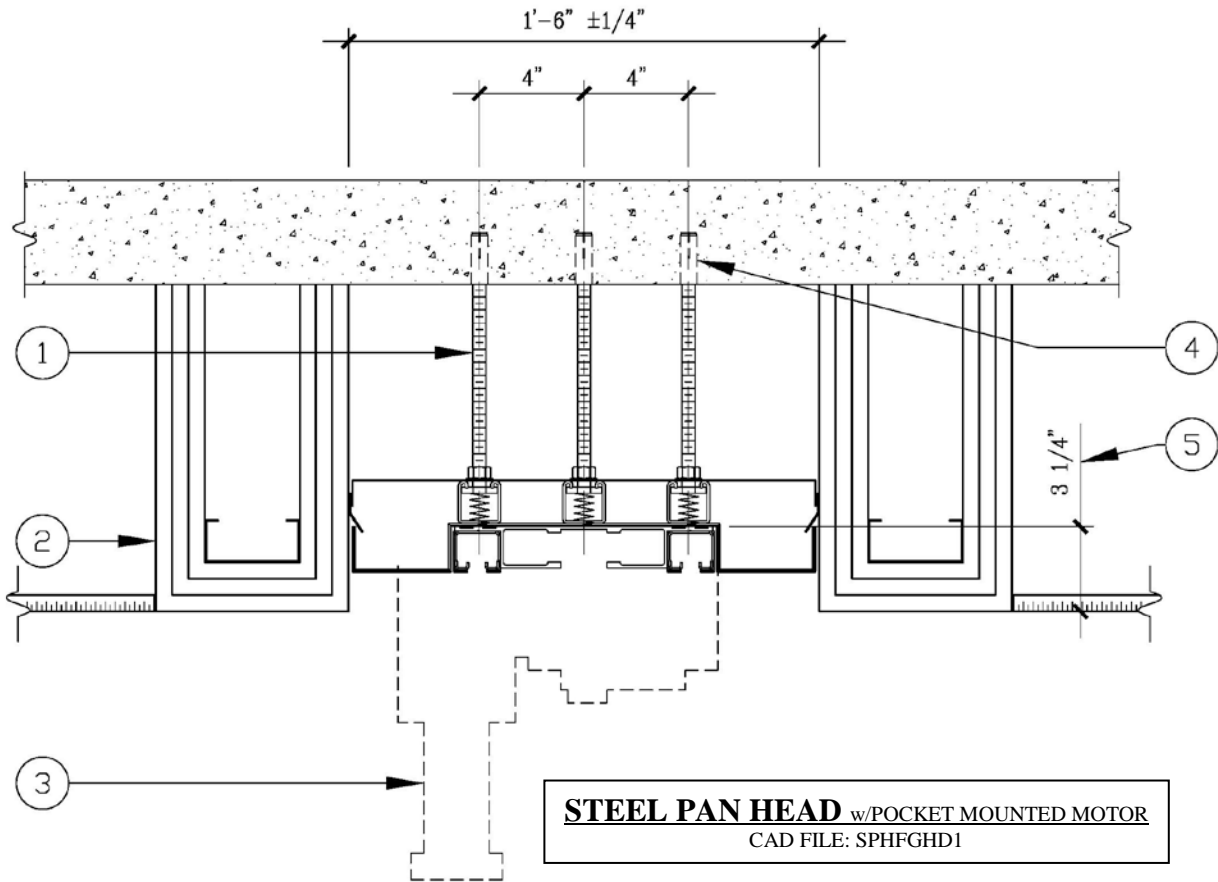

This detail to be used for 3 hour rated doors less than 30'-0" single parting, 60'-0" bi-parting, less than 12'-0" tall.

1. 1/2" threaded rods, Steel Pan Header and track assembly by Won-Door.
2. Provide rated construction on each side corresponding to rating required for opening by others. (Note: 1 hour condition shown. To view additional rated conditions, visit our website @ [www.wondoor.com](http://www.wondoor.com))
3. Motor operator unit. (Mounted at back of pocket. (See page 16)
4. Structural support or anchorage by others. Structural support is not limited to concrete deck.
5. Minimum dimension required to meet U.L. compliance. The dimension may be increased to further recess the head condition if required.

Specifier's  
note

The Steel Pan Header System may be specified for straight doors less than 30'-0" wide and 10'-0" tall.



# Won-Door FireGuard

## STRAIGHT DOOR – PLAN VIEW SINGLE PARTING

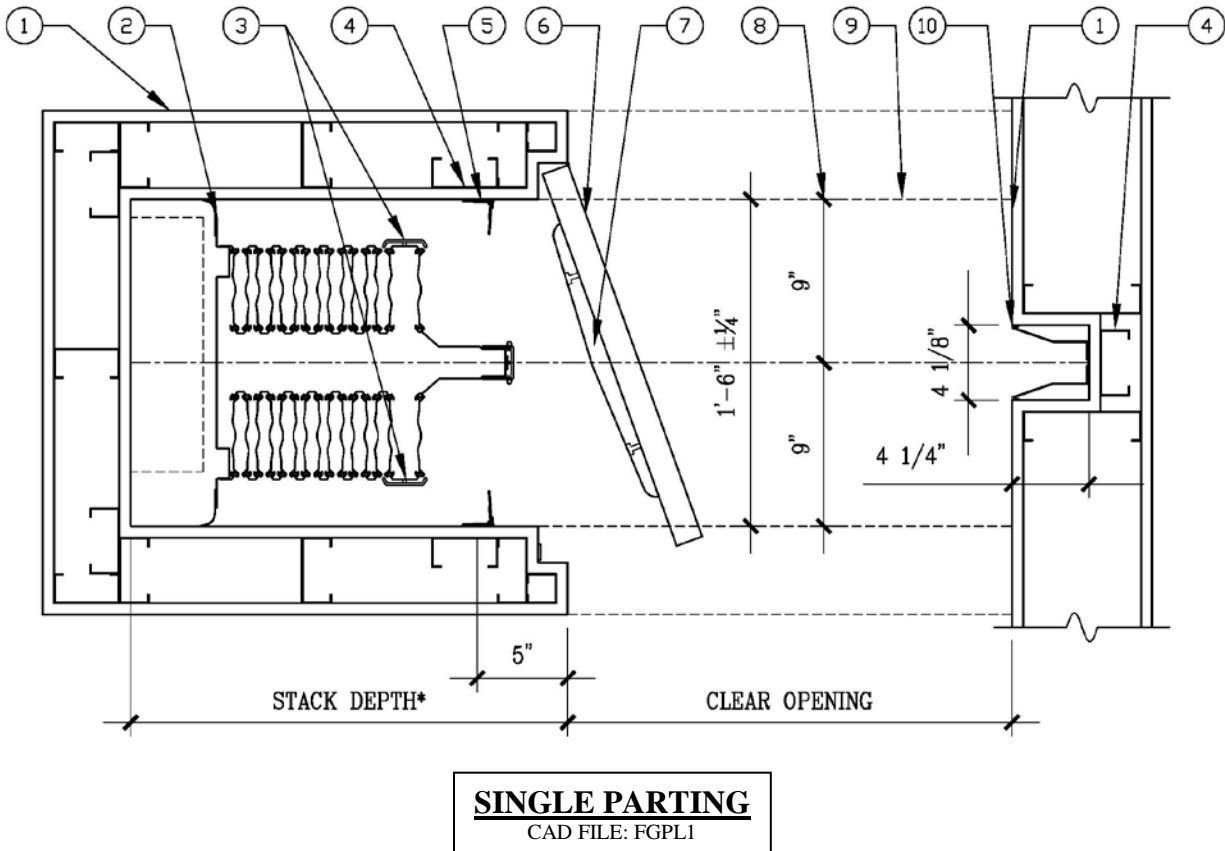

1. Provide rated construction on each side corresponding to rating required for opening by others. (Note: 1 hour condition shown. To view additional rated conditions, visit our website @ [www.wondoors.com](http://www.wondoors.com))
2. Sliding jamb assembly.
3. Exit Devices.
4. Blocking by others.
5. Sliding jamb stops mounted 5" back from face of pocket.
6. Non-rated pocket cover door by others. (See page 29, 30)
7. Door bumper by others required when spring loaded hinge is not used by others. (See page 30)
8. Maintain 9" clearance on each side of the centerline of the door.
9. Fire rated bulkhead above, drop or flush with ceiling.
10. Striker by Won-Door recessed into rated construction and caulked by others.



Brackets [ ] indicate specifier's option

\*To determine pocket depth, see the *Instructions* on page 18 and *Pocket Depth Calculation Chart* on page 19.



# Won-Door FireGuard

## STRAIGHT DOOR – PLAN VIEW BI-PARTING

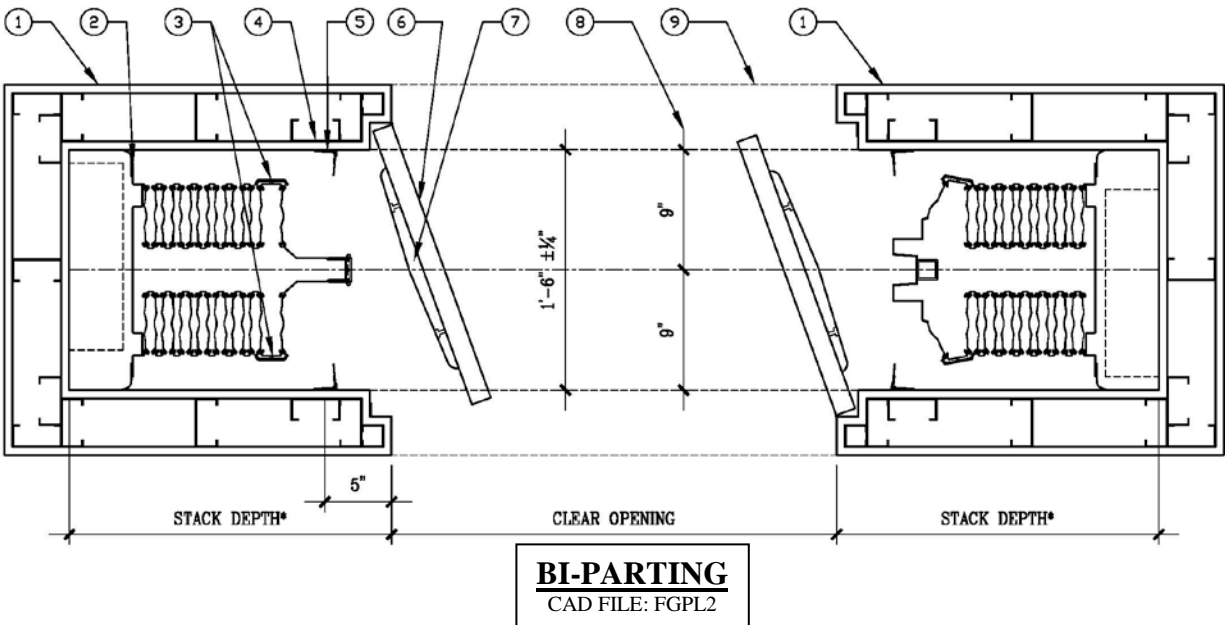

1. Provide rated construction on each side corresponding to rating required for opening by others. (Note: 1 hour condition shown. To view additional rated conditions, visit our website @ [www.wondoors.com](http://www.wondoors.com))
2. Sliding jamb assembly.
3. Exit Devices.
4. Blocking by others.
5. Sliding jamb stops mounted 5" back from face of pocket.
6. Non-rated pocket cover door by others. (See page 29, 30)
7. Door bumper by others. Bumper required when spring loaded hinge is not used. (See page 30)
8. Maintain 9" clearance on each side of the centerline of the door.
9. Fire rated bulkhead above, drop or flush with ceiling.



Brackets [ ] indicate specifier's option

\*To determine pocket depth, see the *Instructions* on page 18 and *Pocket Depth Calculation Chart* on page 19.



# Won-Door FireGuard

## STRAIGHT DOOR – ELEVATION SIDE VIEW

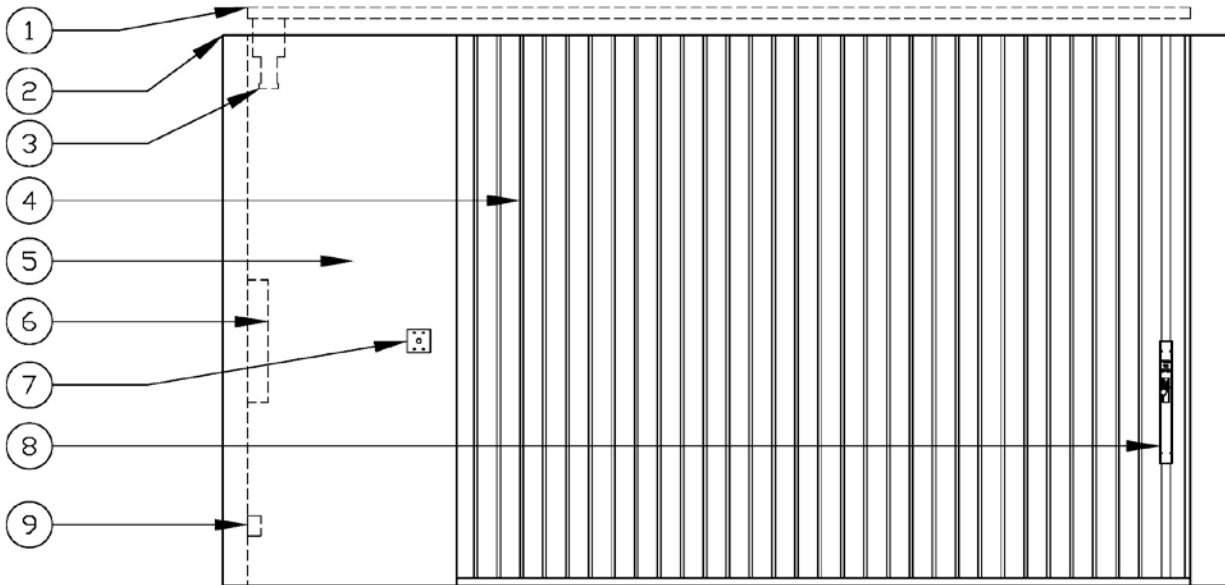

### STANDARD POCKET MOUNTED MOTOR

CAD FILE: FGELEV1

1. Top of door track. (Fabrication height.)
2. Ceiling line.
3. Motor operator assembly.
4. Folding fire door by Won-Door.
5. Storage pocket.
6. Electronic control box by Won-Door.
7. [Optional key switch by Won-Door. (See page 33.)]
8. Fire exit devices mounted 36" A.F.F. (Allows passage through the door when closed.)
9. Two 4" x 4" junction boxes surface mounted side by side on back wall of pocket 12" A.F.F. for required electrical connections.



Brackets [ ] indicate specifier's option



# Won-Door FireGuard

## STRAIGHT DOOR – ELEVATION FRONT VIEW

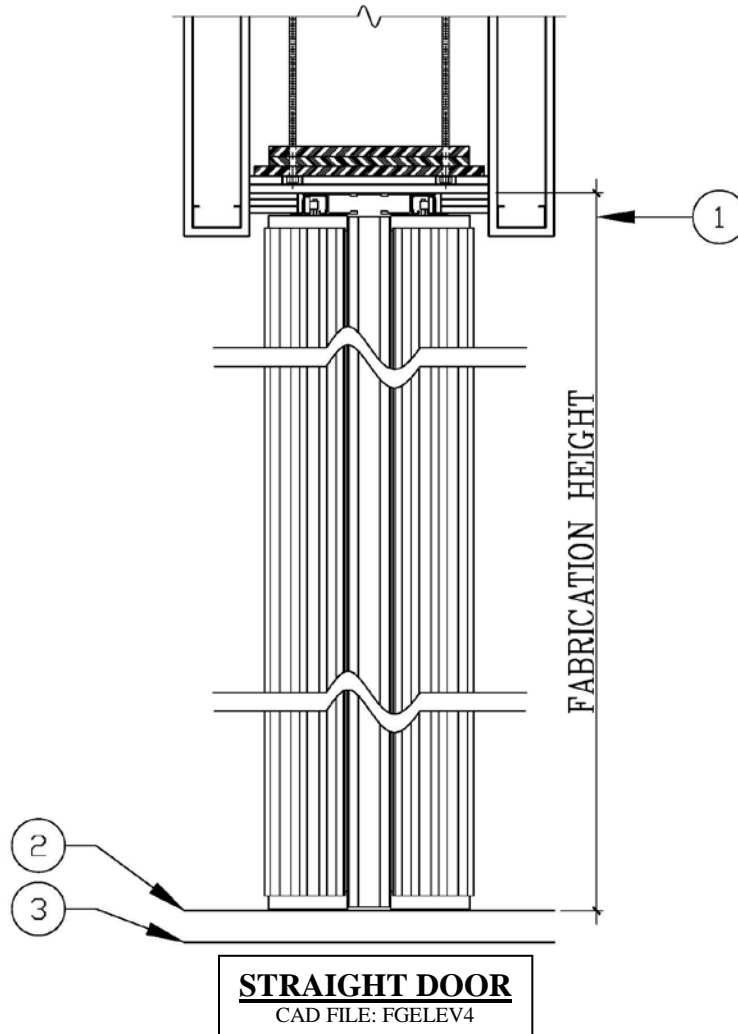

1. Fabrication height/field dimension height taken from top of track to top of finished floor.
2. Finished floor. (Carpet, tile, etc.)
3. Sub floor. (Concrete, etc.)

- Door Profile Widths:
- Stacked Width: 16"
  - Extended Width: 11 1/2"

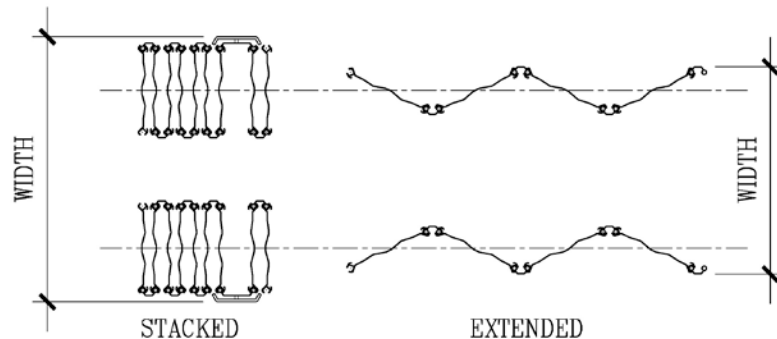

# Won-Door FireGuard

## POCKET DEPTH CHART INSTRUCTIONS

### Single Parting Straight Doors

The term CLEAR OPENING WIDTH on the *POCKET DEPTH CALCULATION CHART* refers to the distance from the front of the storage pocket to face of the striker.

To determine the pocket depth requirement of a door:

1. Determine the door's CLEAR OPENING WIDTH
2. Find the appropriate range for that width (*From-To* columns)
3. Refer to the "Single" (for single parting) column.
4. Consult the *OPTIONS AFFECTING POCKET DEPTH* section below the chart to determine how optional equipment affects stack requirements.

**Example below:** Pocket depth for FireGuard 60 single parting door w/ 8'-4" clear opening (in the range from 8'-2" to 8'-10"). Minimum pocket depth = 3'-2".

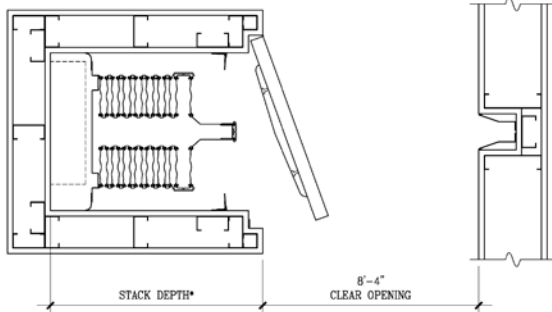

Clear Opening Width		Min. Pocket Depth	
From:	To:	Single	Bi-Part
7'- 5 "	8'- 1 "	3'- 1 "	3'- 6 "
8'- 2 "	8'- 10 "	3'- 2 "	3'- 7 "
8'- 11 "	9'- 7 "	3'- 4 "	3'- 9 "

### Bi Parting Straight Doors

Bi-part doors require two storage pockets. Instead of using the *total* CLEAR OPENING WIDTH when referring to the stack chart, use 1/2 of the CLEAR OPENING WIDTH (which is the distance from the front of storage pocket on one side to the center of the door opening), then follow the same instructions listed in "single parting" (above) to determine the pocket depth requirement. For bi-parting doors, a motor operator can be placed in each pocket to increase the maximum door size for a standard pocket mounted motor. For unequal bi-parting doors, consult the factory.

**Example below:** Pocket depth for FireGuard 60 bi-parting door with 15'-8" clear opening width. Look up 7'-10" on stack chart (1/2 of 15'-8"). Min. pocket depth = 3'-6" for each pocket.

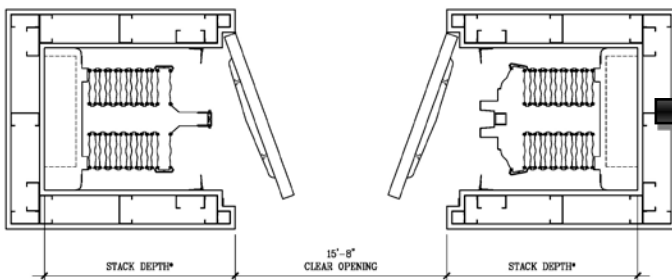

Clear Opening Width		Min. Pocket Depth	
From:	To:	Single	Bi-Part
7'- 5 "	8'- 1 "	3'- 1 "	3'- 6 "
8'- 2 "	8'- 10 "	3'- 2 "	3'- 7 "
8'- 11 "	9'- 7 "	3'- 4 "	3'- 9 "

### List of Options Affecting Pocket Depth

Once you have determined the appropriate depth requirements using the chart on the next page, consult the *OPTIONS AFFECTING POCKET DEPTH* section below the chart. Note that the chart only applies to standard pocket mounted motor Operators with the size limitations listed on the page containing the stack chart. Larger doors will require a Large Door Motor Operator which will affect pocket depth requirements. Optional equipment such as the access control sliding jambs, vision panels, and multiple exit devices will also affect pocket depth as will pocket cover doors in excess of 2" thick.

# Won-Door FireGuard

## STRAIGHT DOOR – POCKET DEPTH CALCULATION CHART

FireGuard 20, 60, 90, 180

Clear Opening Width		Pocket Depth	
From:	To:	Single Parting	Bi-Parting
0'-0"	4'-3"	2'-5"	2'-10"
4'-3"	5'-0"	2'-6"	2'-11"
5'-0"	5'-9"	2'-8"	3'-1"
5'-9"	6'-6"	2'-9"	3'-2"
6'-6"	7'-4"	2'-11"	3'-4"
7'-4"	8'-1"	3'-1"	3'-6"
8'-1"	8'-10"	3'-2"	3'-7"
8'-10"	9'-7"	3'-4"	3'-9"
9'-7"	10'-4"	3'-5"	3'-10"
10'-4"	11'-2"	3'-7"	4'-0"
11'-2"	11'-11"	3'-8"	4'-1"
11'-11"	12'-8"	3'-10"	4'-3"
12'-8"	13'-5"	3'-11"	4'-4"
13'-5"	14'-2"	4'-1"	4'-6"
14'-2"	15'-0"	4'-2"	4'-7"
15'-0"	15'-9"	4'-4"	4'-9"
15'-9"	16'-6"	4'-6"	4'-11"
16'-6"	17'-0"	4'-9"	5'-2"
17'-0"	17'-8"	4'-10"	5'-3"
17'-8"	18'-5"	5'-0"	5'-5"
18'-5"	19'-2"	5'-1"	5'-6"
19'-2"	19'-11"	5'-3"	5'-8"
19'-11"	20'-8"	5'-4"	5'-9"
20'-8"	21'-5"	5'-6"	5'-11"
21'-5"	22'-2"	5'-8"	6'-1"
22'-2"	22'-11"	5'-9"	6'-2"
22'-11"	23'-8"	5'-11"	6'-4"
23'-8"	24'-5"	6'-0"	6'-5"
24'-5"	25'-2"	6'-2"	6'-7"
25'-2"	25'-11"	6'-4"	6'-9"
25'-11"	26'-8"	6'-5"	6'-10"
26'-8"	27'-5"	6'-7"	7'-0"
27'-5"	28'-2"	6'-8"	7'-1"
28'-2"	28'-11"	6'-10"	7'-3"
28'-11"	29'-8"	7'-0"	7'-5"
29'-8"	30'-5"	7'-1"	7'-6"
30'-5"	31'-2"	7'-3"	7'-8"
31'-2"	31'-11"	7'-4"	7'-9"

\*For bi-parting doors: Use 1/2 the clear opening width.

Minimum pocket depth is affected by door height. The charts on this page show minimum pocket depths for doors 10' in height or less.

Minimum pocket depths for taller doors are shown below.

Height	Single	Bi-Part
10'-14'	3'-1"	3'-3"
14'-16'	3'-8"	3'-10"
16'-20'	4'-3"	4'-5"

For doors over 10' in height, if the minimum pocket depth shown on the charts for the required width is less than that shown above, use the appropriate value from above instead. If it is not, use the value shown on the charts.

For doors over 15' in height, the minimum pocket width of 20" is required.

For doors over 20' in height, please consult the factory.

This chart is for straight door openings less than 600 sq.ft. For straight door openings greater than 600 sq.ft., please consult the factory.

Clear Opening Width		Pocket Depth	
From:	To:	Single Parting	Bi-Parting
31'-11"	32'-8"	7'-6"	7'-11"
32'-8"	33'-5"	7'-8"	8'-1"
33'-5"	34'-2"	7'-9"	8'-2"
34'-2"	34'-11"	7'-11"	8'-4"
34'-11"	35'-8"	8'-0"	8'-5"
35'-8"	36'-5"	8'-2"	8'-7"
36'-5"	37'-2"	8'-4"	8'-9"
37'-2"	37'-11"	8'-5"	8'-10"
37'-11"	38'-8"	8'-7"	9'-0"
38'-8"	39'-5"	8'-9"	9'-2"
39'-5"	40'-2"	8'-10"	9'-3"
40'-2"	40'-11"	9'-0"	9'-5"
40'-11"	41'-8"	9'-1"	9'-6"
41'-8"	42'-5"	9'-3"	9'-8"
42'-5"	43'-2"	9'-5"	9'-10"
43'-2"	43'-11"	9'-6"	9'-11"
43'-11"	44'-8"	9'-8"	10'-1"
44'-8"	45'-5"	9'-9"	10'-2"
45'-5"	46'-2"	9'-11"	10'-4"
46'-2"	46'-11"	10'-1"	10'-6"
46'-11"	47'-8"	10'-2"	10'-7"
47'-8"	48'-5"	10'-4"	10'-9"
48'-5"	49'-2"	10'-5"	10'-10"
49'-2"	49'-11"	10'-7"	11'-0"
49'-11"	50'-8"	10'-9"	11'-2"
50'-8"	51'-5"	10'-10"	11'-3"
51'-5"	52'-2"	11'-0"	11'-5"
52'-2"	52'-11"	11'-1"	11'-6"
52'-11"	53'-8"	11'-3"	11'-8"
53'-8"	54'-5"	11'-5"	11'-10"
54'-5"	55'-2"	11'-6"	11'-11"
55'-2"	55'-11"	11'-8"	12'-1"
55'-11"	56'-8"	11'-9"	12'-2"
56'-8"	57'-5"	11'-11"	12'-4"
57'-5"	58'-2"	12'-1"	12'-6"
58'-2"	58'-11"	12'-2"	12'-7"
58'-11"	59'-8"	12'-4"	12'-9"
59'-8"	60'-0"	12'-5"	12'-10"

### Limitations and Considerations:

- Access Control Sliding Jamb:** Add 1" to stack depth.
- Additional Exit Devices:** Add 1" to stack depth for each exit device.
- Pocket Cover Door:** Above charts allow for 2" thick cover door and 1" bumper. Add appropriate amount if cover door and finish materials are thicker than 3".
- FireGuard SE Minimum Stack:** 2'-8" for single parting doors and 3'-1" for bi-parting doors.
- Vision Panel:** Add 6" to stack depth.



# Won-Door FireGuard

## CURVED DOOR – HEAD DETAIL

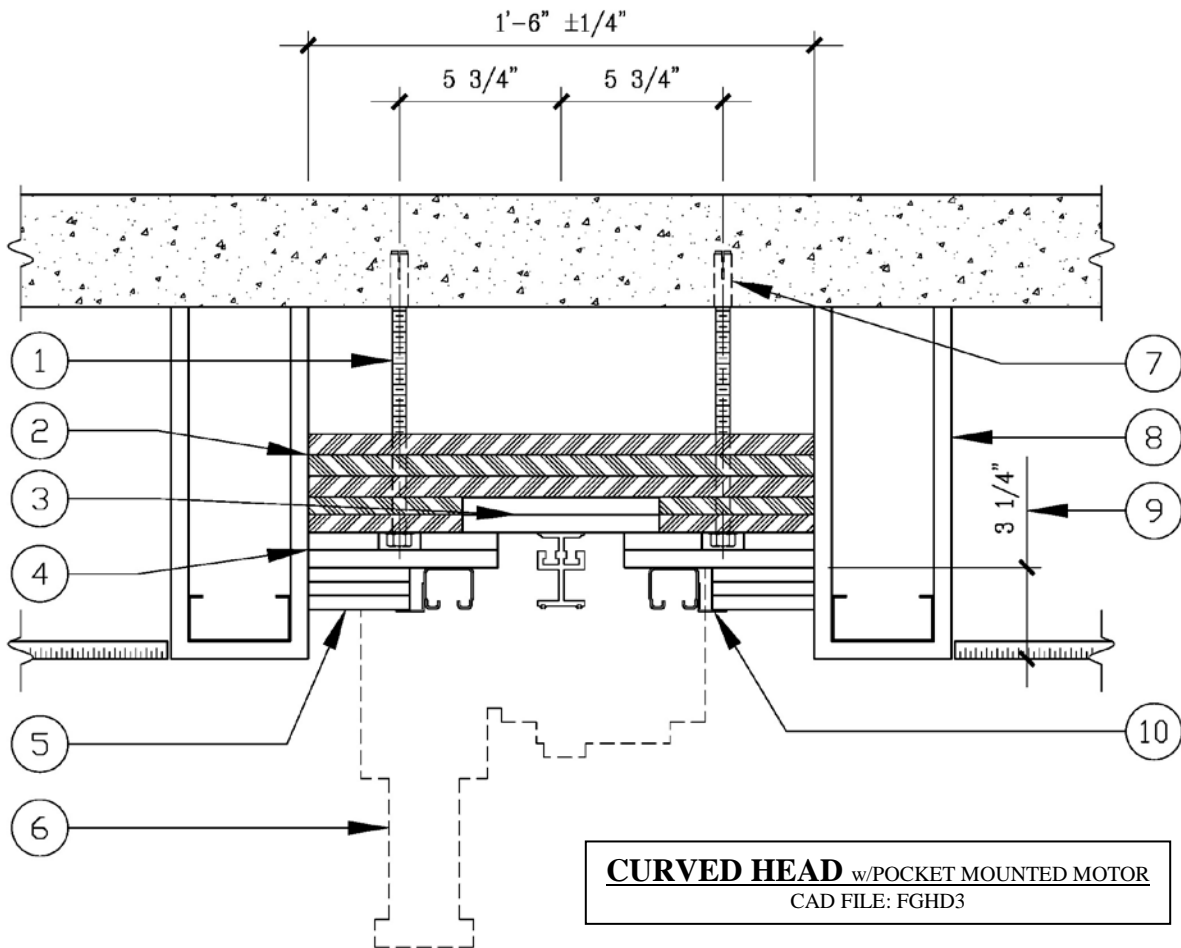

1. 1/2" dia. threaded rod with nuts and washers by others. (18" O.C. in opening, 12" O.C. in stack area.)
2. 3 layers 3/4" x 18" continuous plywood and 2 layers 5/8" x 5 1/2" continuous plywood. Stagger joints, glue and screw together @24" O.C. with 2 #7 x 1 5/8" screws.
3. 2 layers 5/8" x 7" continuous type "X" gypsum board by others.
4. 2 layers 5/8" x 6 3/4" continuous type "X" gypsum board by others.
5. Three layers 1/2" x 3 5/8" type "X" gypsum board terminating 12" into the pocket. All gypsum to be furnished, installed finished, and field painted by others.
6. Motor operator unit. (Mounted at back of pocket. See page 16.)
7. Structural support or anchorage by others. (Structural support is not limited to concrete deck.)
8. Provide rated construction on each side corresponding to rating required for opening by others. (Note: 1 hour condition shown. To view additional rated conditions, visit our website @ [www.wondoors.com](http://www.wondoors.com))
9. Minimum dimension required to meet U.L. compliance. The dimension may be increased to further recess the head condition if required.
10. L-shaped trim piece with pre-finished white color to match track by Won-Door. (Provides transition from track to gypsum soffit.)



Brackets [ ] indicate specifier's option





# Won-Door FireGuard

## CURVED DOOR – PLAN VIEW SINGLE PARTING

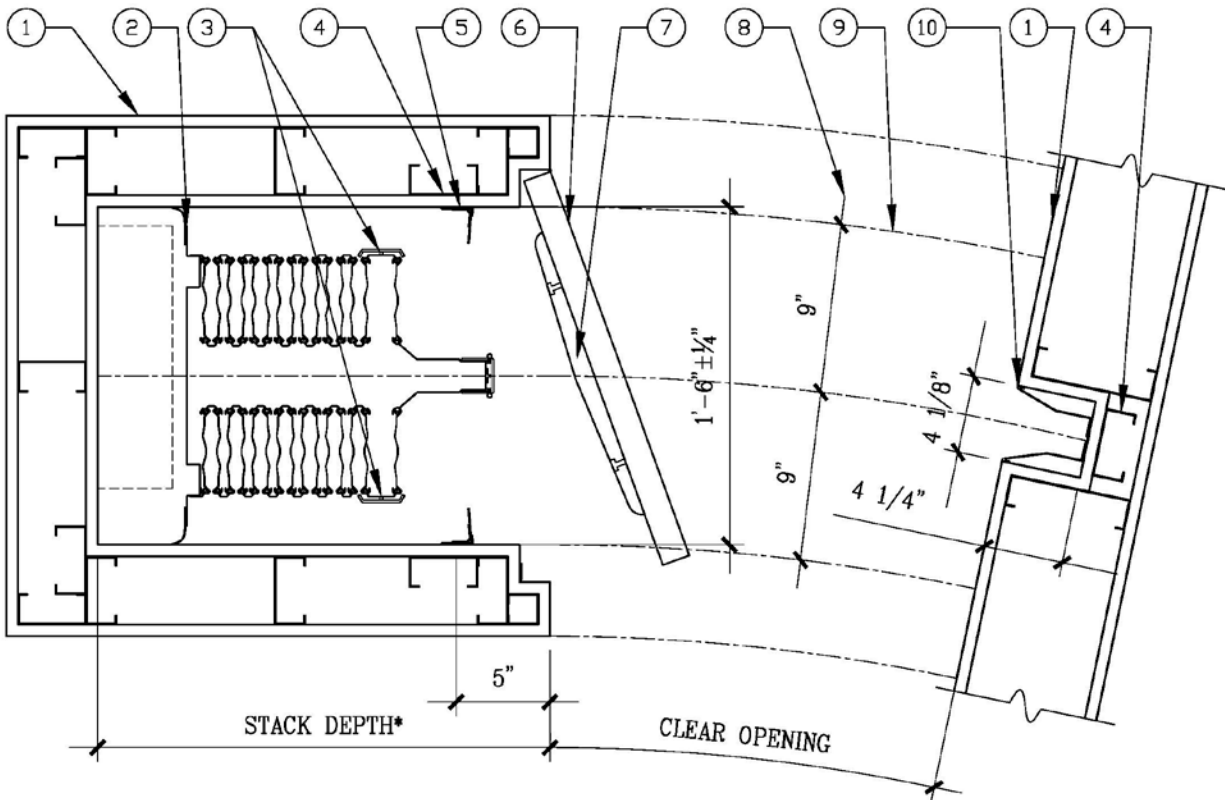

### **CURVED DOOR** CAD FILE: FGPL1

1. Provide rated construction on each side corresponding to rating required for opening by others (Note: 1 hour condition shown. To view additional rated conditions, visit our website @ [www.wondoer.com](http://www.wondoer.com))
2. Sliding jamb assembly.
3. Exit Devices.
4. Blocking by others.
5. Sliding jamb stops mounted 5" back from face of pocket.
6. Non-rated pocket cover door by others. (See page 29, 30)
7. Door bumper by others. Bumper required when spring loaded hinge is not used. (See page 30)
8. Maintain 9" clearance on each side of the centerline of the door.
9. Fire rated bulkhead above, drop or flush with ceiling.
10. Striker by Won-Door recessed into rated construction and caulked by others.

Brackets [ ] indicate specifier's option

\*To determine pocket depth, see *Instructions* on page 25 and *Pocket Depth Calculation Chart* on page 26.

Minimum radius is 5'. Standard radii are 5' and 10'. Custom curves greater than 5' and multiple curves are available.

Specifier's  
note



# Won-Door FireGuard

## CURVED DOOR – PLAN VIEW BI-PARTING

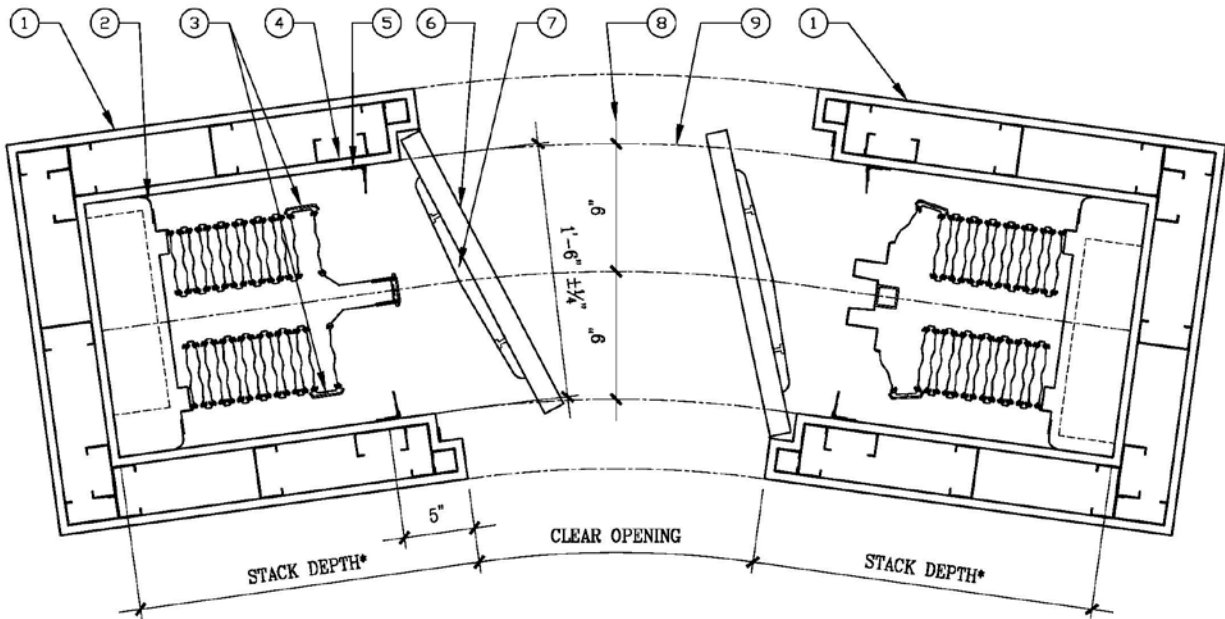

**CURVED DOOR**  
CAD FILE: FGPL2CURVED

1. Provide rated construction on each side corresponding to rating required for opening by others. (Note: 1 hour condition shown. To view additional rated conditions, visit our website @ [www.wondoors.com](http://www.wondoors.com))
2. Sliding jamb assembly.
3. Exit Devices.
4. Blocking by others.
5. Sliding jamb stops mounted 5" back from face of pocket.
6. Non-rated pocket cover door by others. (See page 29, 30)
7. Door bumper by others. Bumper required when spring loaded hinge is not used. (See page 30)
8. Maintain 9" clearance on each side of the centerline of the door.
9. Fire rated bulkhead above, drop or flush with ceiling.

Specifier's  
note

Brackets [ ] indicate specifier's option

\*To determine pocket depth, see *Instructions* on page 25 and *Pocket Depth Calculation Chart* on page 26.

Minimum radius is 5'. Standard radii are 5' and 10'. Custom curves greater than 5' and multiple curves are available.



# Won-Door FireGuard

## CURVED DOOR GUIDELINES

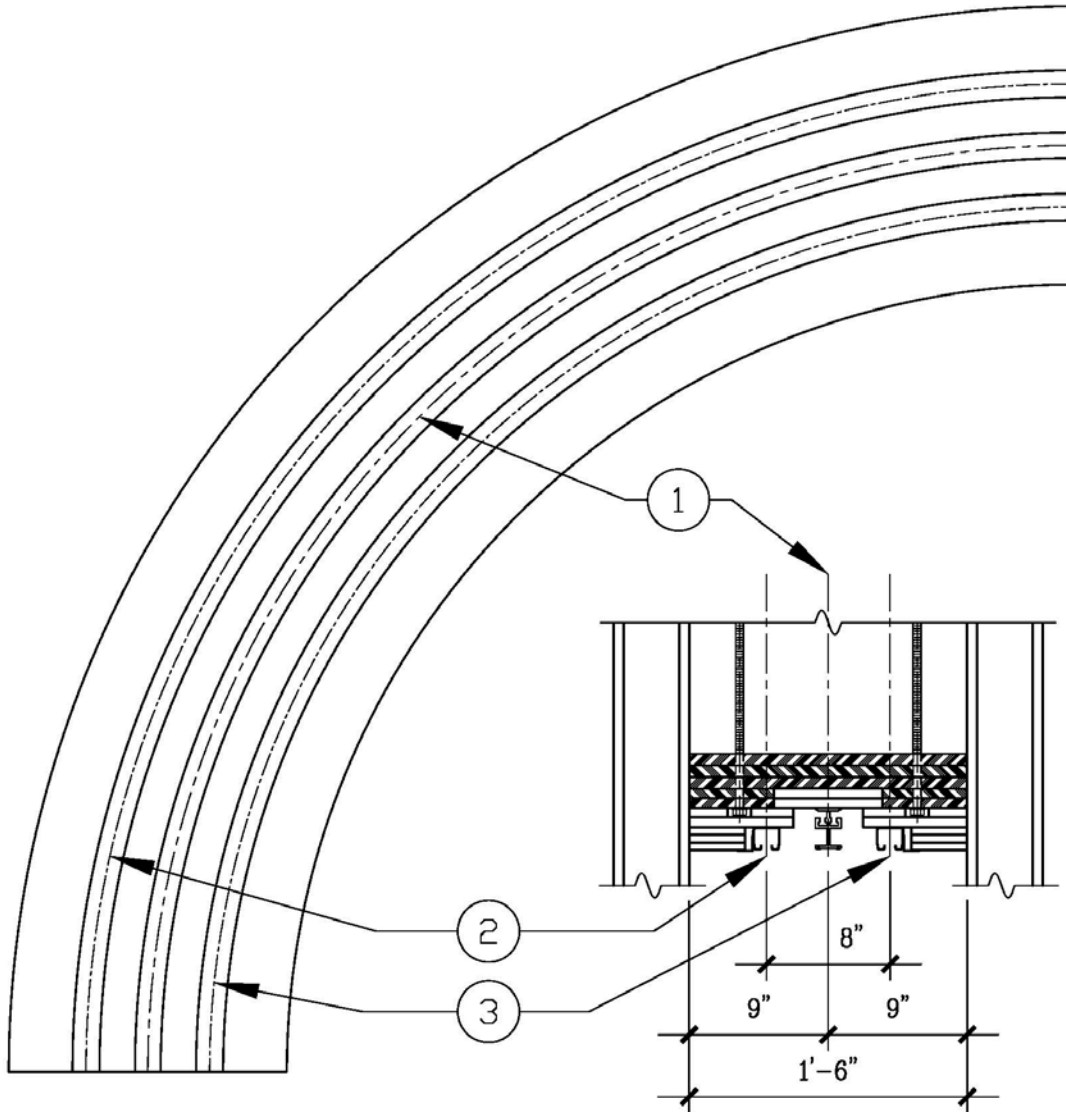

1. Centerline of header. (Radius of curved track is determined by measuring the centerline of the header.)
2. Centerline of outside track.
3. Centerline of inside track.



1. Standard 5' and 10' radius with custom curves greater than 5' and multiple curves available.
2. Templates of header radii are supplied to the field upon request.



# Won-Door FireGuard

## CURVED DOOR – ELEVATION FRONT VIEW

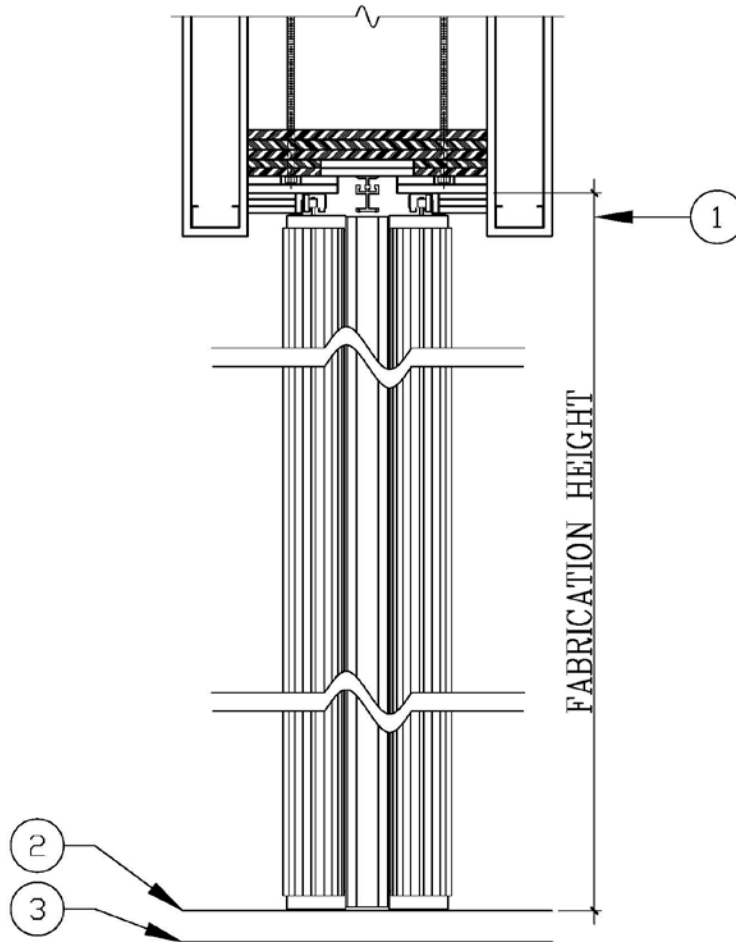

**CURVED DOOR**  
CAD FILE: FGELEV5

1. Fabrication height/field dimension height taken from top of track to top of finished floor.
2. Finished floor. (Carpet, tile, etc.)
3. Sub floor. (Concrete, etc.)

### Door Profile Widths:

- Stacked Width: 16"
- Extended Width: 11 1/2"

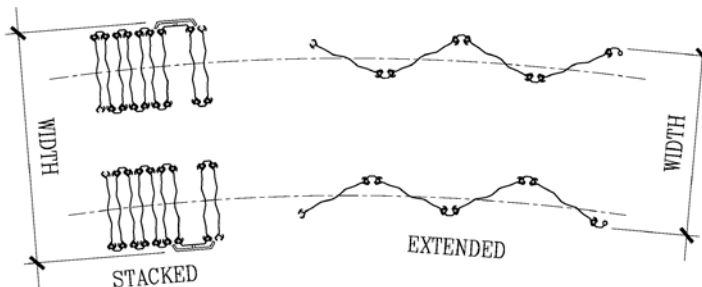

# Won-Door FireGuard

## POCKET DEPTH CHART INSTRUCTIONS

### Single Parting Curved Doors

The term CLEAR OPENING WIDTH on the *Pocket Depth Calculation Chart* refers to the distance from the front of the storage pocket to face of the striker.

To determine the pocket depth requirement of a door:

1. Determine the door's CLEAR OPENING WIDTH
2. Find the appropriate range for that width (*From-To* columns)
3. Refer to the "Single" (for single parting) column.
4. Consult the *Options Affecting Pocket Depth* section below the chart to determine how optional equipment affects stack requirements.

**Example below:** Pocket depth for FireGuard 60 single parting door w/ 8'-4" clear opening (in the range from 8'-2" to 8'-10"). Minimum pocket depth = 3'-2".

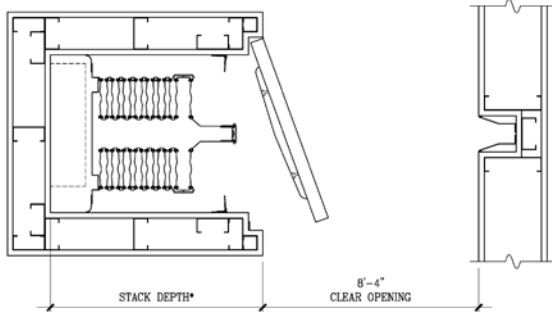

Clear Opening Width		Min. Pocket Depth	
From:	To:	Single	Bi-Part
7'- 3 "	7'- 11 "	3'- 1 "	3'- 6 "
8'- 0 "	8'- 8 "	3'- 3 "	3'- 8 "
8'- 9 "	9'- 5 "	3'- 4 "	3'- 9 "

### Bi Parting Curved Doors

Bi-part doors require two storage pockets. Instead of using the *total* CLEAR OPENING WIDTH when referring to the stack chart, use *1/2* of the CLEAR OPENING WIDTH (which is the distance from the front of storage pocket on one side to the center of the door opening), then follow the same instructions listed in "single parting" (above) to determine the pocket depth requirement. For bi-parting doors, a motor operator can be placed in each pocket to increase the maximum door size for a standard pocket mounted motor. For *unequal* bi-parting doors, consult the factory.

**Example below:** Pocket depth for FireGuard 60 bi-parting door with 15'-8" clear opening width. Look up 7'-10" on stack chart (1/2 of 15'-8"). Min. pocket depth = 3'-6" for each pocket.

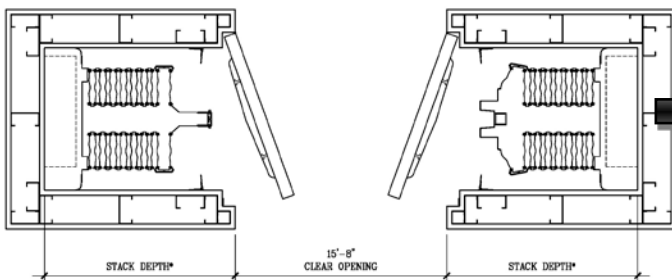

Clear Opening Width		Min. Pocket Depth	
From:	To:	Single	Bi-Part
7'- 3 "	7'- 11 "	3'- 1 "	3'- 6 "
8'- 0 "	8'- 8 "	3'- 3 "	3'- 8 "
8'- 9 "	9'- 5 "	3'- 4 "	3'- 9 "

### List of Options Affecting Pocket Depth

Once you have determined the appropriate depth requirements using the chart on the next page, consult the *Options Affecting Pocket Depth* section below the chart. Note that the chart only applies to standard pocket mounted motor operators with the size limitations on the page containing the stack chart. Larger doors will require a Large Door Motor Operator which will affect pocket depth requirements. Optional equipment such as the access control sliding jambs, vision panels, and multiple exit devices will also affect pocket depth as will pocket cover doors in excess of 2" thick.



# Won-Door FireGuard

## CURVED DOOR – POCKET DEPTH CALCULATION CHART

FireGuard 20, 60, 90, 180

Clear Opening Width		Pocket Depth	
From:	To:	Single Parting	Bi-Parting
0'-0"	9'-0"	3'-3"	3'-8"
9'-0"	9'-9"	3'-4"	3'-9"
9'-9"	10'-6"	3'-6"	3'-11"
10'-6"	11'-3"	3'-8"	4'-1"
11'-3"	12'-0"	3'-9"	4'-2"
12'-0"	12'-9"	3'-11"	4'-4"
12'-9"	13'-6"	4'-0"	4'-5"
13'-6"	14'-3"	4'-2"	4'-7"
14'-3"	15'-0"	4'-4"	4'-9"
15'-0"	15'-9"	4'-5"	4'-10"
15'-9"	16'-6"	4'-7"	5'-0"
16'-6"	17'-3"	4'-8"	5'-1"
17'-3"	18'-0"	4'-10"	5'-3"
18'-0"	18'-9"	5'-0"	5'-5"
18'-9"	19'-6"	5'-1"	5'-6"
19'-6"	20'-3"	5'-3"	5'-8"
20'-3"	21'-0"	5'-4"	5'-9"
21'-0"	21'-9"	5'-6"	5'-11"
21'-9"	22'-6"	5'-8"	6'-1"
22'-6"	23'-3"	5'-9"	6'-2"
23'-3"	24'-0"	5'-11"	6'-4"
24'-0"	24'-9"	6'-0"	6'-5"
24'-9"	25'-6"	6'-2"	6'-7"
25'-6"	26'-3"	6'-4"	6'-9"
26'-3"	27'-0"	6'-5"	6'-10"
27'-0"	27'-9"	6'-7"	7'-0"
27'-9"	28'-6"	6'-8"	7'-1"
28'-6"	29'-3"	6'-10"	7'-3"
29'-3"	30'-0"	7'-0"	7'-5"
30'-0"	30'-9"	7'-1"	7'-6"
30'-9"	31'-6"	7'-3"	7'-8"
31'-6"	32'-3"	7'-4"	7'-9"
32'-3"	33'-0"	7'-6"	7'-11"
33'-0"	33'-9"	7'-8"	8'-1"
33'-9"	34'-6"	7'-9"	8'-2"
34'-6"	35'-3"	7'-11"	8'-4"
35'-3"	36'-0"	8'-0"	8'-5"
36'-0"	36'-9"	8'-2"	8'-7"

\*For bi-parting doors: Use 1/2 the clear opening width. Minimum pocket depth is affected by door height. The charts on this page show minimum pocket depths for doors 10' in height or less.

Minimum pocket depths for taller doors are shown below.

Height	Single	Bi-Part
10'-14"	3'-9"	3'-11"
14'-16"	3'-9"	3'-11"
16'-20"	5'-3"	5'-5"

For doors over 10' in height, if the minimum pocket depth shown on the charts for the required width is less than that shown above, use the appropriate value from above instead. If it is not, use the value shown on the charts.

For doors over 15' in height, the minimum pocket width of 20" is required.

For doors over 20' in height, please consult the factory.

This chart is for straight door openings less than 500 sq.ft. For straight door openings greater than 500 sq.ft., please consult the factory.

Clear Opening Width		Pocket Depth	
From:	To:	Single Parting	Bi-Parting
36'-9"	37'-6"	8'-4"	8'-9"
37'-6"	38'-3"	8'-5"	8'-10"
38'-3"	39'-0"	8'-7"	9'-0"
39'-0"	39'-9"	8'-9"	9'-2"
39'-9"	40'-6"	8'-10"	9'-3"
40'-6"	41'-3"	9'-0"	9'-5"
41'-3"	42'-0"	9'-1"	9'-6"
42'-0"	42'-9"	9'-3"	9'-8"
42'-9"	43'-6"	9'-5"	9'-10"
43'-6"	44'-3"	9'-6"	9'-11"
44'-3"	45'-0"	9'-8"	10'-1"
45'-0"	45'-9"	9'-9"	10'-2"
45'-9"	46'-6"	9'-11"	10'-4"
46'-6"	47'-3"	10'-1"	10'-6"
47'-3"	48'-0"	10'-2"	10'-7"
48'-0"	48'-9"	10'-4"	10'-9"
48'-9"	49'-6"	10'-5"	10'-10"
49'-6"	50'-3"	10'-7"	11'-0"
50'-3"	51'-0"	10'-9"	11'-2"
51'-0"	51'-9"	10'-10"	11'-3"
51'-9"	52'-6"	11'-0"	11'-5"
52'-6"	53'-3"	11'-1"	11'-6"
53'-3"	54'-0"	11'-3"	11'-8"
54'-0"	54'-9"	11'-5"	11'-10"
54'-9"	55'-6"	11'-6"	11'-11"
55'-6"	56'-3"	11'-8"	12'-1"
56'-3"	57'-0"	11'-9"	12'-2"
57'-0"	57'-9"	11'-11"	12'-4"
57'-9"	58'-6"	12'-1"	12'-6"
58'-6"	59'-3"	12'-2"	12'-7"
59'-3"	60'-0"	12'-4"	12'-9"

### Limitations and Considerations:

- Access Control Sliding Jamb:** Add 1" to stack depth.
- Additional Exit Devices:** Add 1" to stack depth for each exit device.
- Pocket Cover Door:** Above charts allow for 2" thick cover door and 1" bumper. Add appropriate amount if cover door and finish materials are thicker than 3".
- Vision Panel:** Add 6" to stack depth.



# Won-Door FireGuard

## POCKET DEPTH CHART INSTRUCTIONS

### Single Parting Straight 90TR Doors

The term CLEAR OPENING WIDTH on the *Pocket Depth Calculation Chart* refers to the distance from the front of the storage pocket to face of the striker.

To determine the pocket depth requirement of a door:

1. Determine the door's CLEAR OPENING WIDTH
2. Find the appropriate range for that width (*From-To* columns)
3. Refer to the "Single" (for single parting) column.
4. Consult the *Options Affecting Pocket Depth* section below the chart to determine how optional equipment affects stack requirements.

**Example below:** Pocket depth for FireGuard 90TR single parting door w/ 8'-4" clear opening (in the range from 8'-2" to 8'-10"). Minimum pocket depth = 3'-2".

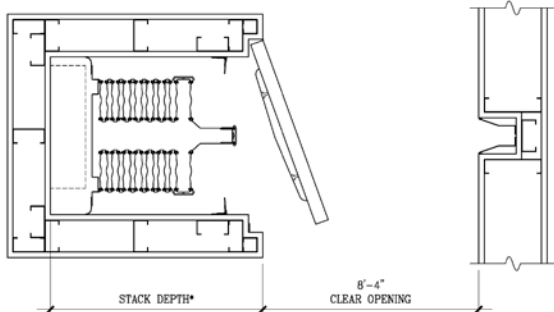

Clear Opening Width		Min. Pocket Depth	
From:	To:	Single	Bi-Part
7'- 5 "	8'- 1 "	3'- 1 "	3'- 6 "
8'- 2 "	8'- 10 "	3'- 2 "	3'- 7 "
8'- 11 "	9'- 7 "	3'- 4 "	3'- 9 "

### Bi Parting Straight 90TR Doors

Bi-part doors require two storage pockets. Instead of using the *total* CLEAR OPENING WIDTH when referring to the stack chart, use 1/2 of the CLEAR OPENING WIDTH (which is the distance from the front of storage pocket on one side to the center of the door opening), then follow the same instructions listed in "single parting" (above) to determine the pocket depth requirement. For bi-parting doors, a motor operator can be placed in each pocket to increase the maximum door size for a standard pocket mounted motor. For *unequal* bi-parting doors, consult the factory.

**Example below:** Pocket depth for FireGuard 90TR bi-parting door with 15'-8" clear opening width. Look up 7'-10" on stack chart (1/2 of 15'-8"). Min. pocket depth = 3'-6" for each pocket.

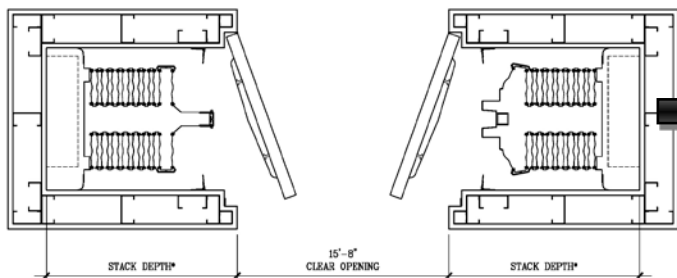

Clear Opening Width		Min. Pocket Depth	
From:	To:	Single	Bi-Part
7'- 5 "	8'- 1 "	3'- 1 "	3'- 6 "
8'- 2 "	8'- 10 "	3'- 2 "	3'- 7 "
8'- 11 "	9'- 7 "	3'- 4 "	3'- 9 "

### List of Options Affecting Pocket Depth

Once you have determined the appropriate depth requirements using the chart on the next page, consult the *Options Affecting Pocket Depth* section below the chart. Note that the chart only applies to standard pocket mounted motor Operators with the size limitations listed on the page containing the stack chart. Larger doors will require a Large Door Motor Operator which will Affect pocket depth requirements. Optional equipment such as the access control sliding jambs and multiple exit devices will also affect pocket depth as will pocket cover doors in excess of 2" thick.



# Won-Door FireGuard

## POCKET DEPTH CALCULATION CHART TR FireGuard 90TR

Clear Opening Width		Pocket Depth	
		Single Parting	Bi-Parting
From:	To:		
0'-0"	3'-10"	2'-8"	3'-1"
3'-10"	4'-7"	2'-11"	3'-4"
4'-7"	5'-4"	3'-2"	3'-7"
5'-4"	6'-2"	3'-4"	3'-9"
6'-2"	6'-11"	3'-7"	4'-0"
6'-11"	7'-8"	3'-10"	4'-3"
7'-8"	8'-5"	4'-1"	4'-6"
8'-5"	9'-3"	4'-3"	4'-8"
9'-3"	10'-0"	4'-6"	4'-11"
10'-0"	10'-9"	4'-9"	5'-2"
10'-9"	11'-6"	5'-0"	5'-5"
11'-6"	12'-4"	5'-2"	5'-7"
12'-4"	13'-1"	5'-5"	5'-10"
13'-1"	13'-10"	5'-8"	6'-1"
13'-10"	14'-7"	5'-11"	6'-4"
14'-7"	15'-5"	6'-1"	6'-6"
15'-5"	16'-2"	6'-4"	6'-9"
16'-2"	16'-11"	6'-7"	7'-0"
16'-11"	17'-8"	6'-8"	7'-1"
17'-8"	18'-6"	6'-11"	7'-4"
18'-6"	19'-3"	7'-2"	7'-7"
19'-3"	20'-0"	7'-4"	7'-9"
20'-0"	20'-9"	7'-7"	8'-0"
20'-9"	21'-7"	7'-10"	8'-3"
21'-7"	22'-4"	8'-1"	8'-6"
22'-4"	23'-1"	8'-3"	8'-8"
23'-1"	23'-10"	8'-6"	8'-11"
23'-10"	24'-8"	8'-9"	9'-2"
24'-8"	25'-5"	9'-0"	9'-5"
25'-5"	26'-2"	9'-2"	9'-7"
26'-2"	26'-11"	9'-5"	9'-10"
26'-11"	27'-9"	9'-8"	10'-1"
27'-9"	28'-6"	9'-11"	10'-4"
28'-6"	29'-3"	10'-1"	10'-6"
29'-3"	30'-0"	10'-4"	10'-9"

\*For bi-parting doors: Use 1/2 the clear opening width.

### Limitations and Considerations:

- Access Control Sliding Jamb:** Add 1" to stack depth.
- Pocket Cover Door:** Above charts allow for 2" thick cover door and 1" bumper. Add appropriate amount if cover door and finish materials are thicker than 3".
- Additional Exit Devices:** Add 1" to stack depth for each exit device.





# Won-Door FireGuard

## POCKET COVER DOOR GUIDELINES

Pocket cover doors are not required, but may be used to aesthetically conceal Won-Door FireGuard doors. When properly done, they add to the continuity of the project and provide anonymity to the installation.

Won-Door Corporation does not manufacture or install pocket cover doors. Therefore, they should be specified in a separate specification section. Unless specifically required by the Authority Having Jurisdiction, pocket doors need not be fire-rated, but solid core doors are preferable for reasons of durability. The door thickness and covering material is at the discretion of the designer. Many covering materials have been successfully used including: plastic laminates, wood veneers, vinyl, paint, bronze, stainless steel, and marble. If the aggregate thickness of the pocket cover door exceeds 2", however, the additional thickness must be added to the calculation of the pocket depth (see *Pocket Depth Calculation Chart* on page 18, 25.)

Some basic criteria for the successful design of pocket cover doors are listed below:

1. Doors must be side hinge swinging and must swing at least 90°. When in the open position, pocket doors may not encroach on the 18" minimum opening width required for the pocket. Designing "notches" on either side of the pocket opening to accommodate the cover door thickness will prevent this (see *Pocket Cover Door Detail* on page 30.)
2. Cover doors must be operable with less than 50 lbs. of lateral force. As the Won-Door FireGuard door is activated, the leading edge will make contact with the cover door and push it open. 50 lbs. is the normal operating force required for egress-type swinging doors and only if the cover door is unusually heavy would special considerations need to be taken.
3. When activated, pocket doors should remain in the open position so as not to obstruct the path of the Won-Door FireGuard door when it is closing.
4. Won-Door recommends specifying either (a) a spring-action such as the Hager #1257 (with reversed spring action) to hold the cover door open when activated **or** (b) a continuous hinge such as a Stanley #314.
  - a. The reversed spring action in the Hager #1257 butt hinge makes the cover door self-opening rather than self-closing. Cover doors without spring action hinges may swing back into the operating path of the Won-Door FireGuard and cause damage or obstruct emergency operation.
  - b. For aesthetic considerations, a continuous hinge is preferable because it does not protrude beyond the face of the pocket cover door and therefore presents a "hinge less" appearance. When a continuous hinge is used, however, a "bumper" is required. The bumper prevents the pocket door from swinging back in to the operating path of the Won-Door FireGuard. Won-door does not provide bumpers, but its design is shown on page 30.
5. A magnetic catch not to exceed 30 lbs. can serve to keep the pocket cover doors in the closed position when the Won-Door FireGuard door is not in use. Positive latches such as hooks or throw bolts are not permitted because they prevent the Won-door FireGuard door from pushing the cover door open during operation.
6. A door frame is not required although one may be used. For aesthetic considerations, however, a "frame less" design may be preferable because it leaves only two slight reveals at the door edges and provides a less noticeable pocket door installation.



# Won-Door FireGuard

## POCKET COVER DOOR DETAIL

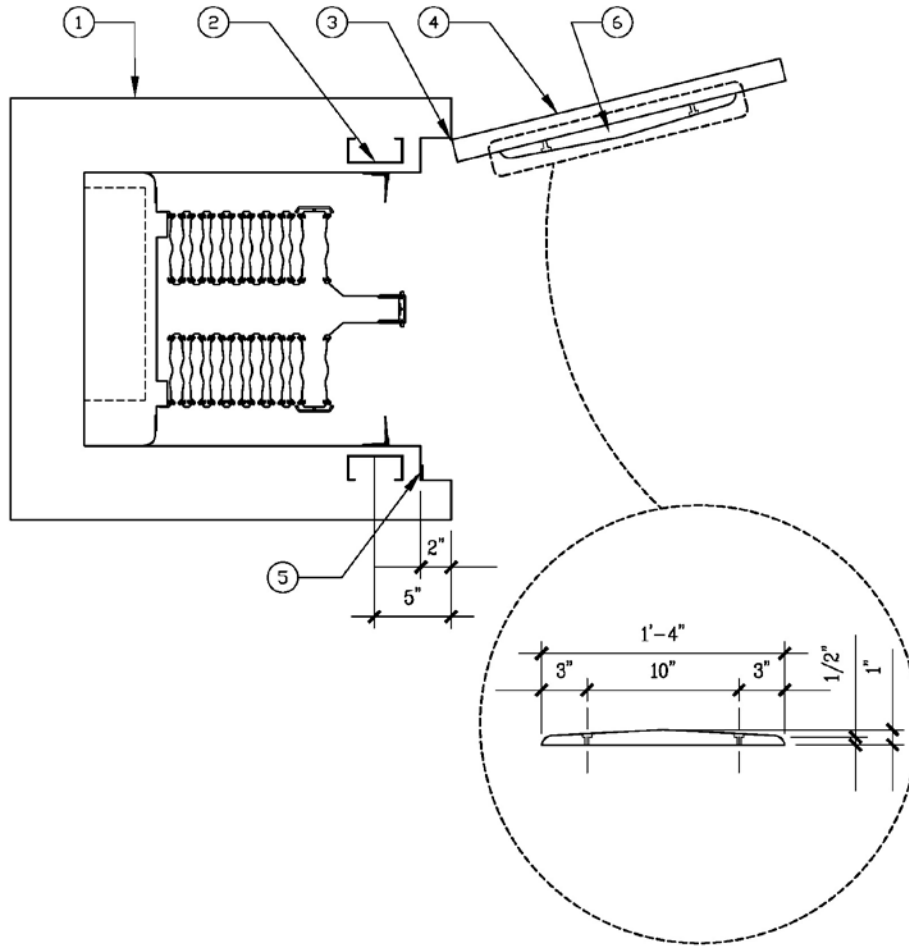

1. Provide fire rated construction corresponding to rating required for opening by others. (1 hour construction shown).
2. Blocking for sliding jamb stops centered at 5" from face of pocket by others.
3. Spring action hinge or continuous hinge by others.
4. Non-rated pocket cover door by others.
5. Magnetic catch (not to exceed 30 lbs.) by others.
6. Bumper (mounted on inside of pocket cover door 3" above finished floor) by others.



Bumpers must be specified when non-spring action hinges are used.



# Won-Door FireGuard

## POCKET MOUNTED MOTOR OPERATOR ELECTRICAL DIAGRAM

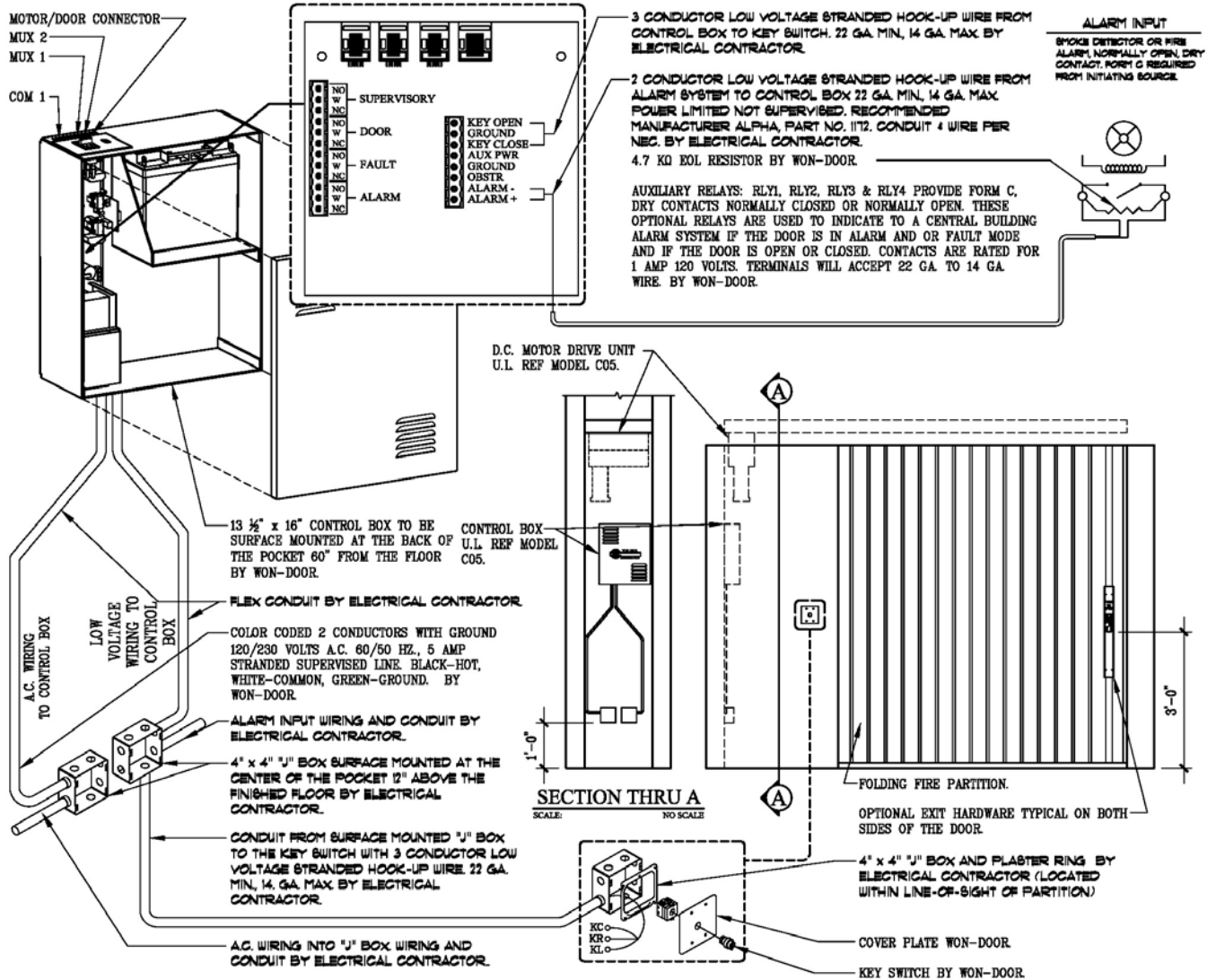

Specifier's note

Note: Cable lengths referred to in this detail are actual cable lengths, not straight line distances. If cable length exceeds 25 wire feet, consult the factory.  
Key switch is required with access control.



# Won-Door FireGuard

## LARGE DOOR MOTOR OPERATOR ASSEMBLY WIRING DIAGRAM

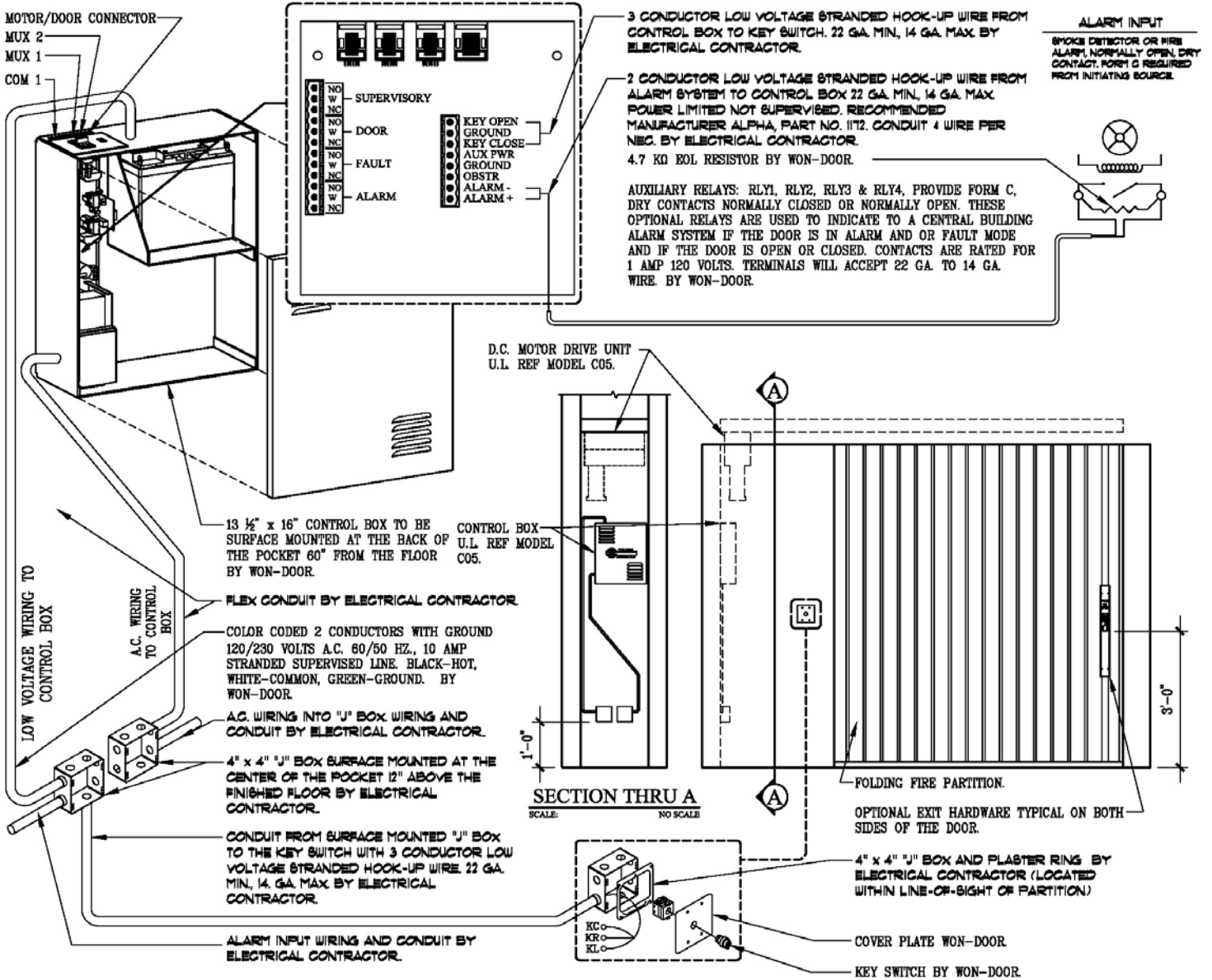

Note: Cable lengths referred to in this detail are actual cable lengths, not straight line distances. If cable length exceeds 25 wire feet, consult the factory.



# Won-Door FireGuard

## OPTIONAL KEY SWITCH

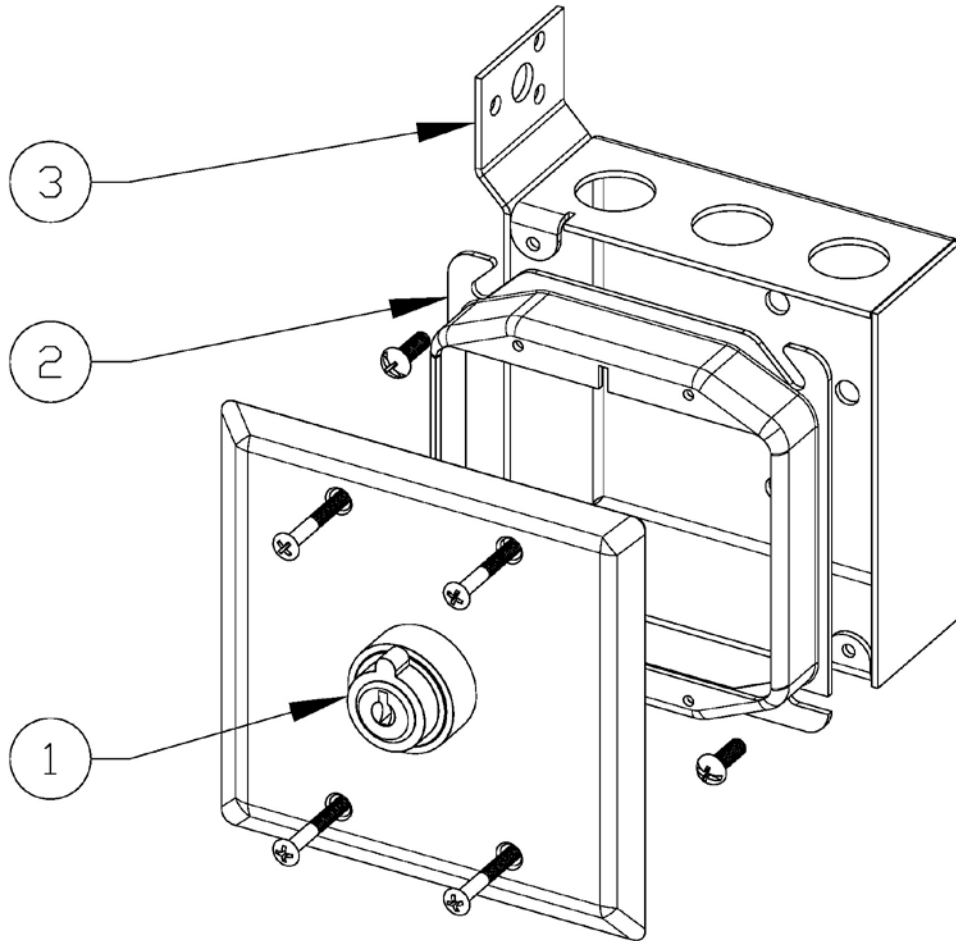

1. Key switch module.
2. Plaster ring by others.
3. 4" x 4" x 2 1/2" electrical box by others.

Key switches are *optional* except for the following applications:

1. Large door motor operator assemblies
2. Access control options.

Specifier's  
note

For safety reasons, a key switch must be installed within line-of-sight of the operation of the Won-Door FireGuard door.



# Won-Door FireGuard

## CCOM ROCKER SWITCH

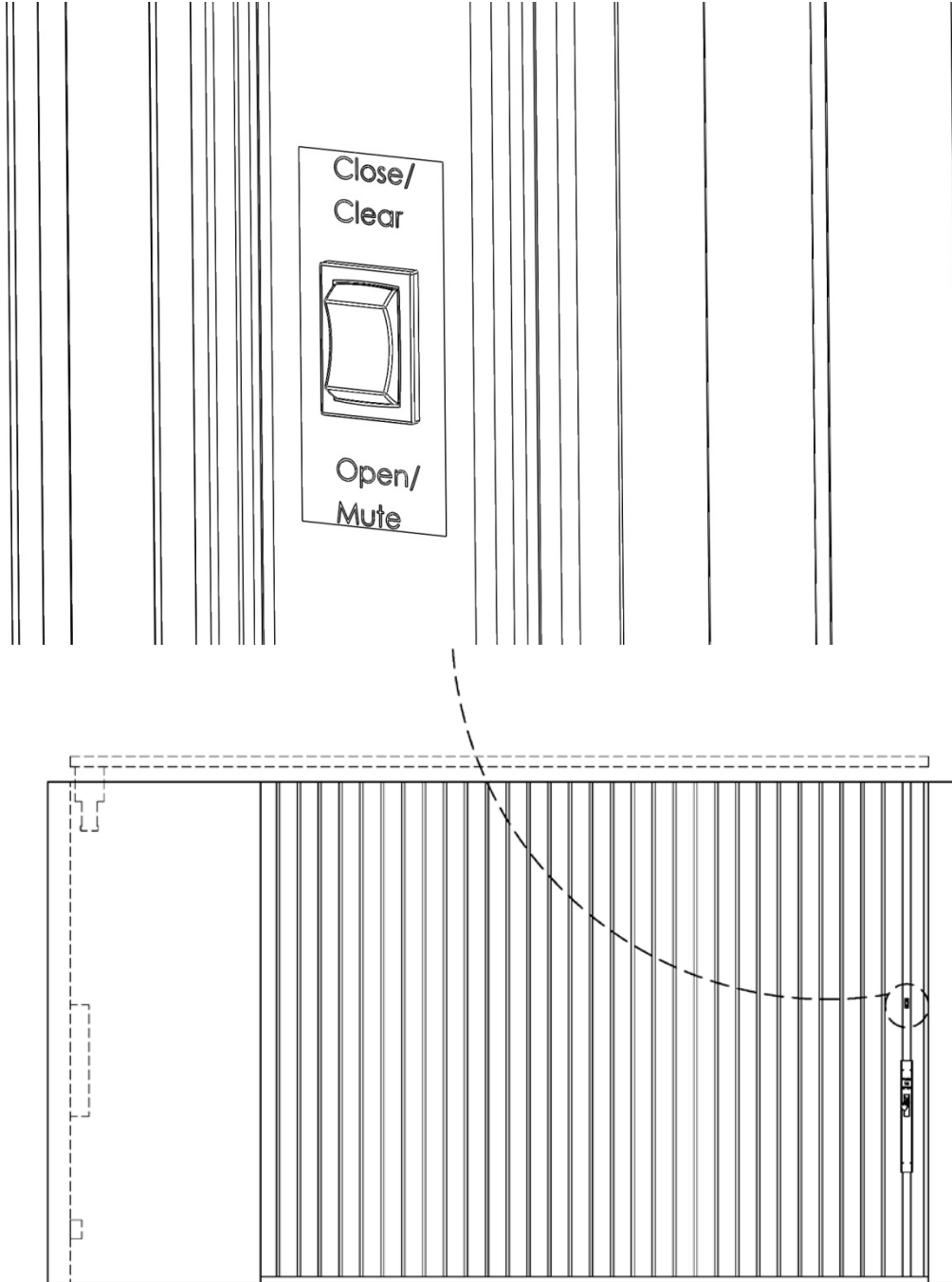

CCOM rocker switch is included when a key switch is not specified. The switch is used to open and close the door and to reset and silence door faults.



# Won-Door FireGuard

## OPTIONAL VISION PANEL

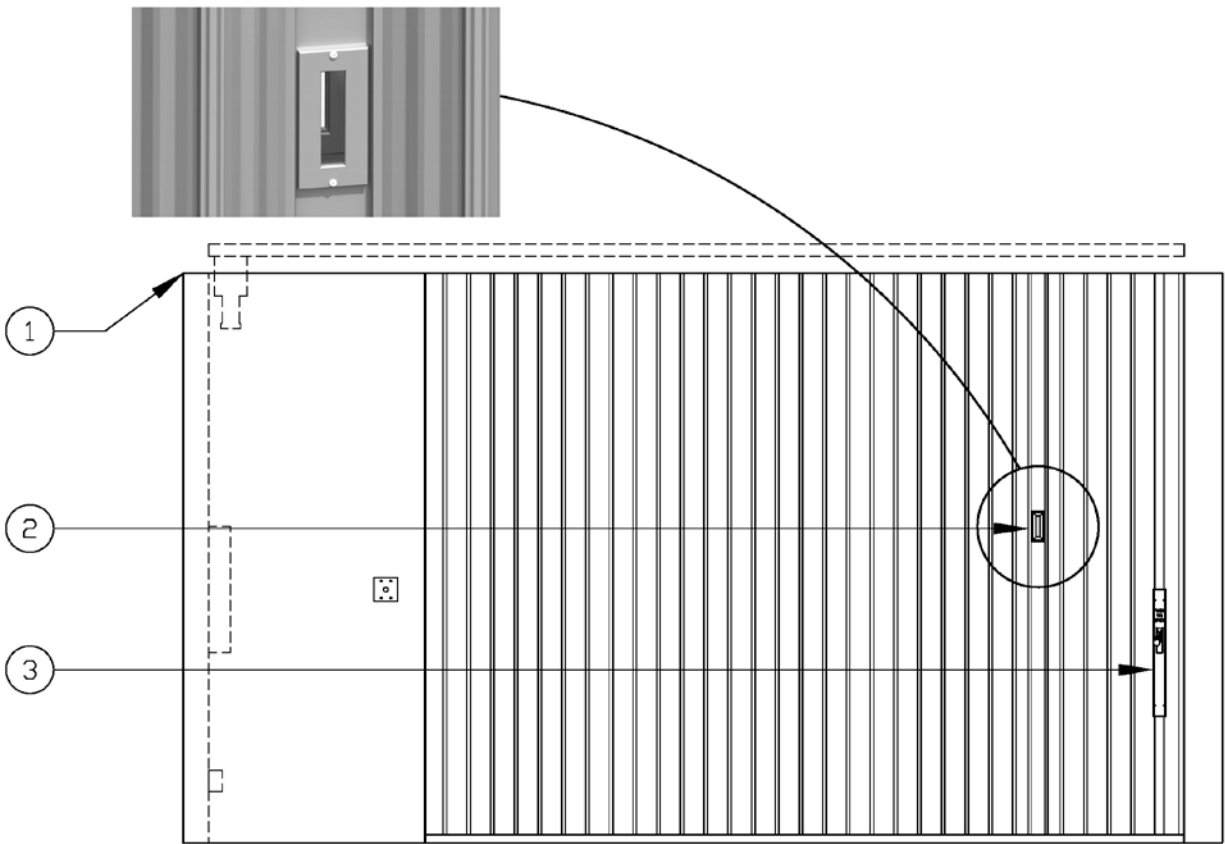

1. Ceiling line.
2. 1 1/2-hour U.L. listed Vision Panel. Required only for smoke barrier applications in Group I occupancies. Maximum size is 5 3/4" x 2 5/8".
3. Exit devices.



Add 6" to pocket depth for vision panel (*except* when the vision panel is required to be closer than 48" to the leading edge of the door or 96" on a curved door. In these cases, contact the factory for details.)



# Won-Door FireGuard

## OPTIONAL INDIVIDUAL LCD DOOR STATUS DISPLAY

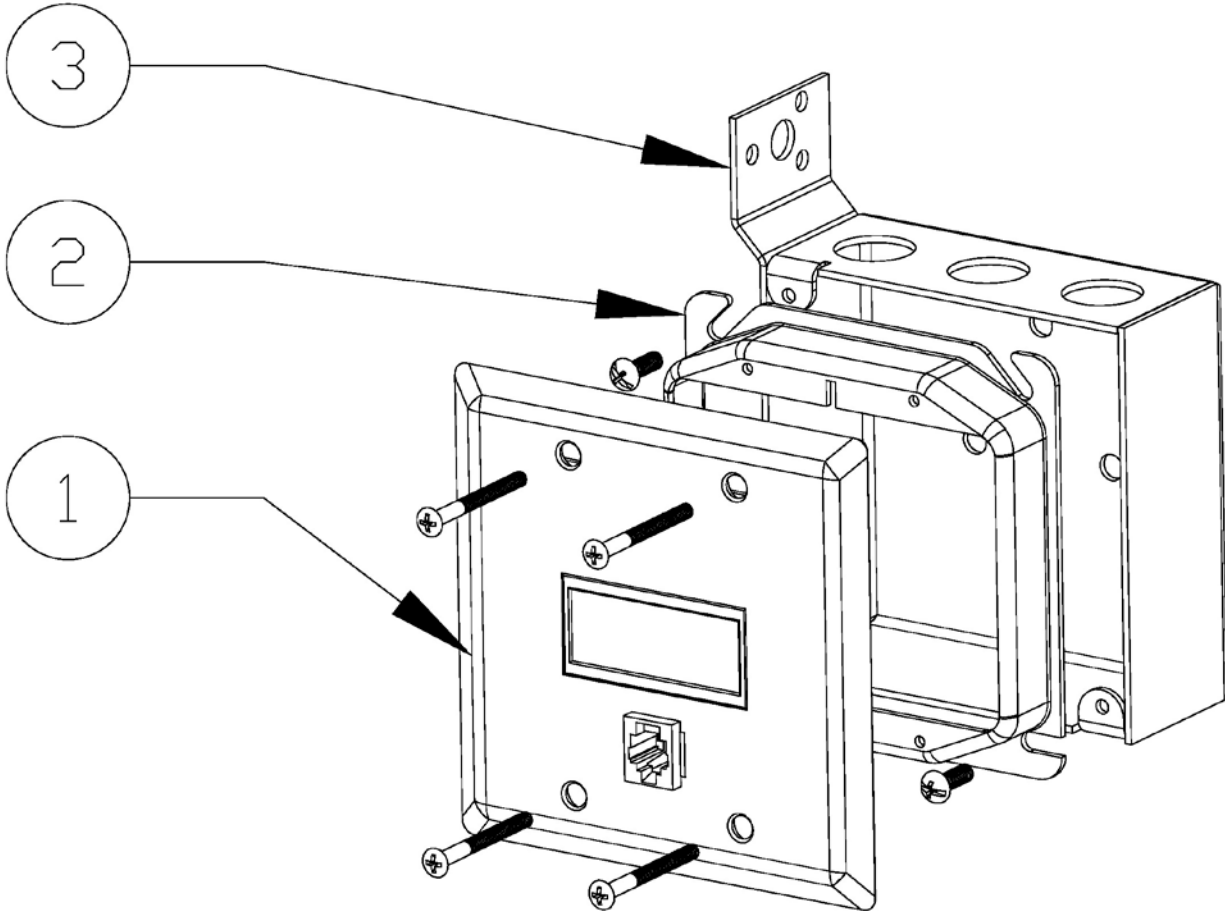

1. Individual LCD Door Status Display module.
2. Plaster ring by others.
3. 4" x 4" electrical box by others.

Specifier's  
note

The Individual LCD Door Status Display communicates door status & fault information to building tenants. Mounted in a standard 4" x 4" recessed "J" box.





# Won-Door FireGuard

## OPTIONAL MULTIPLE EXIT DEVICE DETAIL

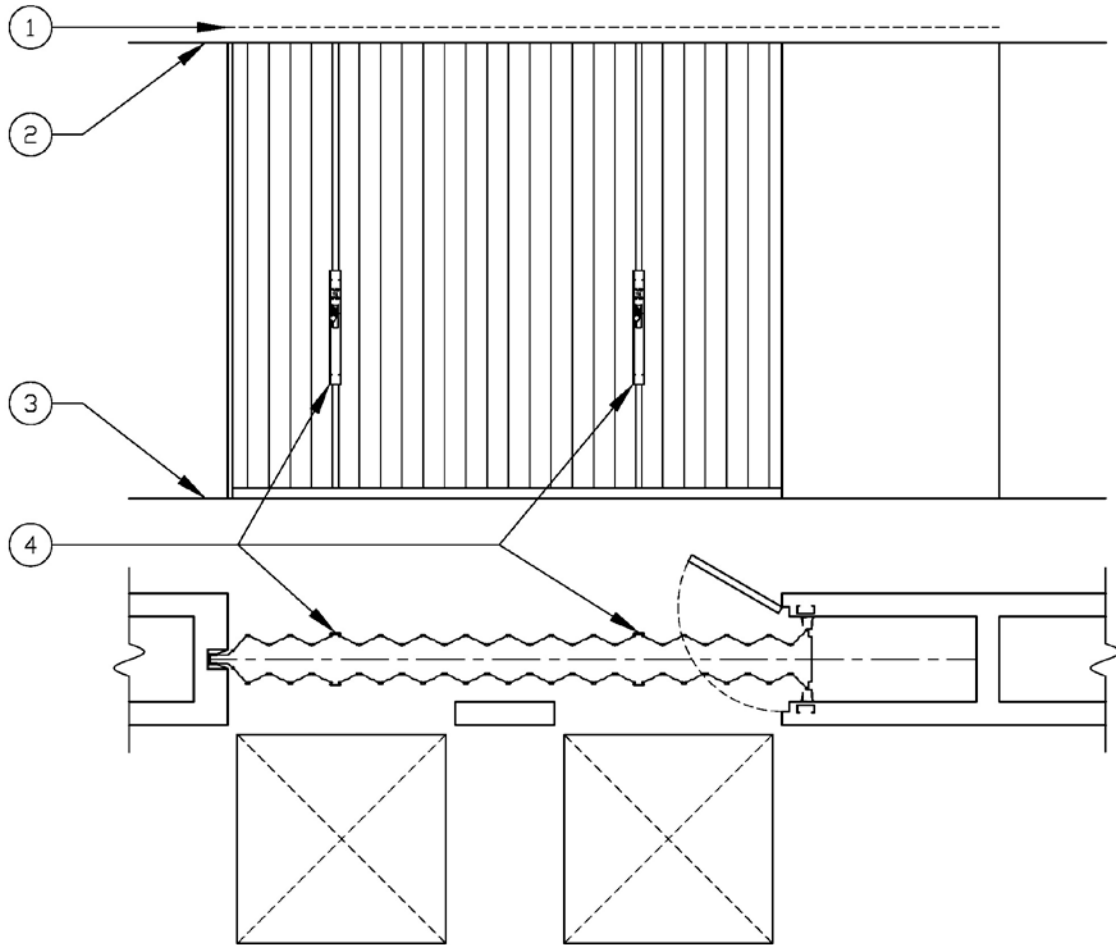

1. Top of track.
2. Ceiling line.
3. Finished floor.
4. Exit devices mounted 36" A.F.F. (In sets, one on *each side* of the door, **or** one side only.)



1. Up to three (3) sets of exit devices per leaf may be specified at any horizontal locations on the door (example above shows two sets in front of a bank of elevators). Upon activation of the exit device, the FireGuard door will open to a field-programmable distance.
2. Add 1" to stack or pocket depth for each set of exit devices.



# Won-Door FireGuard Stock Door

This page intentionally left blank.

# Won-Door FireGuard Stock Door

## SECTION 08 35 13.23 – ACCORDION FOLDING FIRE DOORS

### PART 1 – GENERAL

#### 1.01 SUMMARY OF WORK

- A. Division 0 and 1, as indexed, apply to this section.
- B. Furnish and install all horizontal sliding, accordion folding fire doors shown on the drawings and specified herein.

#### 1.02 RELATED SECTIONS

- A. All headers, support structures, fire protection of support structures, surrounding insulation, jambs, storage pockets, blocking and trim shall be furnished and installed by other sections.
- B. All electrical wire, wiring, conduit and electrical boxes shall be furnished and installed by electrical section.
- C. Drilling/placement of anchorage points into pre or post tensioned decks, welding/punching/drilling steel members and all drywall work.

#### 1.03 QUALITY ASSURANCE

- A. Installation shall be performed by factory trained and certified installers with a minimum of three years experience installing electrically operated accordion folding fire doors.
- B. Fire doors shall be listed by Underwriters Laboratories for ratings as indicated, when tested in accordance with the requirements of UL 10B NFPA 252.
- C. Automatic closing system shall be listed by Underwriters Laboratories in accordance with the requirements of UL 864 and be listed for use with the assembly in compliance with NFPA 80, Chapter 9.
- D. Fire doors used for smoke and draft control shall bear the “S” mark on the fire door label and shall have an air leakage of less than  $3 \text{ ft}^3/\text{ft}^2$  at 0.1 inch of water column pressure when tested in accordance with UL 1784 with an artificial bottom seal.
- E. Fire Doors shall be capable of resisting an air pressure differential up to 0.05 inches of water column. Air pressure resistance to 0.1 inches of water column available. (*See Section 2.03 J*)

#### 1.04 SUBMITTALS

- A. See Section 01 30 00 – Administrative Requirements, for submittal procedures.
- B. Product Data: Provide manufacturer’s technical literature, include UL listing data.
- C. Shop Drawings: Indicate construction and installation details and dimensions, including layout, electrical requirements, required stack depth, height of header above finished floor, and requirements for anchorage and support of each door.
- D. Operation and Maintenance Data: Operating procedures, troubleshooting and repair methods, and wiring diagrams.

#### 1.05 DELIVERY, STORAGE, AND HANDLING

- A. Deliver to the job site in manufacturer's original, unopened package, labeled to show name, brand and type.
- B. Store products in a protected dry location. Replace damaged materials on-site at no cost to owner.



# Won-Door FireGuard Stock Door

## 1.06 COORDINATION BY GENERAL CONTRACTOR

- A. Coordinate with the following:
  - 1. Fire Alarm system.
  - 2. Electrical.
  - 3. Panel pocket doors finish and wood veneer paneling (if applicable).
  - 4. Floor and ceiling finish.
- B. Assure accurate installation of header, jamb, and trim. Provide “As-Built” dimensions for opening and storage pocket. Supervise unloading and handling of materials.
- C. Store boxes flat (not more than three high) in a protected dry area. Replace damaged materials at no cost to owner.
- D. Permanent power shall be in-place and ready for final connection when fire doors are installed. Assure access to and proper clearance for motor operators.
- E. After testing the fire alarm system, automatic-closing fire doors shall be re-set to the original position.

## 1.07 WARRANTY

- A. Materials and installation shall be warranted against defects in workmanship for a period of one (1) year from the date of substantial completion.

## PART 2 – PRODUCTS

### 2.01 MANUFACTURERS

- A. Horizontal sliding accordion folding fire doors shall be Won-Door FireGuard Stock Door model FG-\_\_\_\_ (select one: 20, 60, or 90 – number designates minutes of fire rating) as manufactured by Won-Door Corporation, Salt Lake City, UT.
- B. Products of other manufacturers demonstrating complete compliance with each of the fire rating and performance criteria of the product specified will be considered for approval. Written requests for substitutions will be considered by the architect up to ten days prior to the bid date.
- C. **OPTION:** No substitutions allowed.

### 2.02 ACCORDION FIRE DOORS – GENERAL

- A. Provide electrically powered self-closing fire doors of configurations indicated on the drawings.
  - 1. Fire rating as required.
- B. Fire Rating – Fire doors shall be listed by Underwriters Laboratory as special purpose fire doors having a (*select one: 20, 60, or 90*) minute fire-resistive rating in accordance with the requirements of UL 10B and NFPA 252.
- C. Closing and Opening Operation: Automatic Closing System including motor operator and releasing devices shall be a Microprocessor-based system rated to UL864 (Releasing Device Control Unit) and shall commence closing upon activation by fire alarm system and/or by low battery charge.



# Won-Door FireGuard Stock Door

1. Obstruction Detection: Contact with an obstruction shall cause the door to stop, reverse enough to remove pressure on the leading edge, pause, and then re-close when in an alarm condition.
  2. While the door is opening under motor power, constant pressure to the leading edge in the direction of opening shall cause the door to continue to open until the leading edge is released. This is termed motor-assisted opening.
  3. Constant pressure to the leading edge while not under motor power shall prevent motor operation and allow the door to be opened manually.
- D. Exit Device Operation: Provide fire exit devices on both sides of door.
1. In emergency mode, a slight pressure on the devices will cause the door to open a minimum of 32 inches, pause for 3 seconds, and then automatically close.
  2. The open distance shall be field programmable, up to the entire opening width, if the local authority requires an opening larger than 32 inches.
  3. The pause before re-close shall be field programmable, up to 30 seconds, if the local authority requires a longer pause time.
  4. The exit devices shall have the ability when not in the emergency (fire) mode to be used to open the door and move it back into the storage pocket.
  5. **OPTION:** The exit devices shall be field programmable to provide access control. When programmed, the exit devices shall not respond when pressed until activated by signal from smoke detector or fire alarm.

## 2.03 COMPONENTS

- A. Door Construction: Two parallel, accordion-type walls independently suspended with no floor tracks, pantographs, or interconnections.
1. Panels: 24 gauge steel, V-grooved; modular in design; capable of in-place repair.
  2. Perimeter Seals: shall consist of continuous extruded vinyl sweeps attached to the top and bottom of the fire door to form a smoke and draft seal.
  3. Hanging Weight: 5.5 pounds per sq. ft. when extended across opening.
  4. Finish: All steel parts factory-applied enamel.
  5. Color: Manufacturer's standard platinum.
- B. Suspension System: Two tracks, on 8 inch centers, attached to overhead structural support.
1. Tracks: .125 aluminum.
  2. Panel Hangers: Every other panel is suspended by a steel hanger pin and ball bearing roller.
  3. Lead Post Hangers: 16-gauge steel structural tube frame with 18-gauge steel preformed cover. The lead post shall function as an integrated cover panel over the storage pocket opening when the fire door is in the open position.
- C. Power Supply: 12-volt maintenance-free DC battery, automatically maintained at capacity by continuous charger, 120 V AC.
- D. Automatic Closing System shall be listed to UL864 including capability to send and receive signals from the Fire Control Panel, and shall consist of the following:



# Won-Door FireGuard Stock Door

1. Microprocessor based Electronic Control box with the ability to:
  - a. Monitor dual power sources continually for peak performance including:
    - 1) Detect a missing battery, bad battery, or low battery condition.
    - 2) Detect if the charging circuit is bad.
    - 3) Detect fuse failures.
    - 4) Detect high or low AC conditions.
  - b. Monitor the health of the drive train.
  - c. Monitor inputs including: sticky door block, exit devices, patron devices, and key switches.
  - d. Run a “watch dog” monitoring circuit which will force a software restart in the event the software hangs, including tracking the number of resets that occur for diagnostic purposes.
  - e. Withstand voltages up to 120 volts AC on the fire alarm input circuit without damage including the ability to indicate that the alarm circuit has not been wired as a dry contact, “no voltage” circuit when errant voltages are applied to the circuit.
  - f. Communicate with other microprocessors on the system via an internal buss system.
  - g. Indicate faults or supervised information both locally and at a remote location.
2. Motor Operator Assembly including a DC gear-motor, drive sprocket, clutch, and position sensors. The motor shall drive the fire door by means of a chain attached to a stabilizer bar trolley. The motor shall be rated for continuous use with unlimited cycle duty.
3. A door control momentary rocker switch shall be mounted on one side of the door and shall function as follows:
  - a. Pressing the upper portion shall close the door and/or clear fault conditions.
  - b. Pressing the lower portion of the switch shall open the door and/or temporarily mute the local horn.
4. Leading Edge Obstruction Detector shall be pressure sensitive such that contact with an obstruction shall cause the door to stop, pause for 3 seconds, then re-close when in alarm mode. The obstruction detection system shall be fully functional at all times.
5. Exit Devices will be located on both sides of each fire door.
- E. The header shall be eliminated because of the Unitized Track System. Self-supporting track, threaded rods and mechanical attachment hardware are included.
- F. Striker: Surface mounted striker jambs.
- G. **OPTION:** Vision Panel located at the leadpost consisting of a frame and clear glass assembly with listings from Underwriters Laboratory up to 90 minutes. *(Required only in smoke barriers in Group I Occupancies)*



# Won-Door FireGuard Stock Door

## 2.04 RELATED CONSTRUCTION

- A. Track Support Construction: Provide supports attached to structure and mounting surface for track including drilling/placement of anchorage points into pre or post tensioned decks, welding/punching/drilling steel members, and all drywall work; comply with door manufacturer's instructions and recommendations.
- B. Pocket Construction: Provide pocket for concealment of accordion door when open; comply with door manufacturer's instructions and recommendations.

## PART 3 – EXECUTION

### 3.01 EXAMINATION

- A. Verify that adjacent construction is suitable for installation of door.
- B. Verify that electrical utilities have been installed and are accessible.
- C. Verify that door opening is plumb and header is level and of correct dimensions.
- D. Notify Architect of any unacceptable conditions or varying dimensions.

### 3.02 INSTALLATION

- A. Install in accordance with manufacturer's instructions, shop drawings and NFPA 80.
- B. Install fire doors parallel with the finished floor.

### 3.03 ADJUSTING

- A. Adjust door installation to provide uniform clearances and smooth, quiet, non-binding operation.
- B. Test that all operations are functional and meet the requirements of local codes.

### 3.04 CLEANING

- A. Clean surfaces using manufacturer's recommended means and methods.

### 3.05 PROTECTION

- A. Protect installed work from damage.

### 3.06 STORAGE OF WASTE AND RECYCLING

- A. Store and recycle waste in accordance with Section 01 74 19 Construction Waste Management and Disposal.

Copyright © 2013 by Won-Door Corporation, all rights reserved.  
END OF SECTION



# Won-Door FireGuard Stock Door

This page intentionally left blank.





# Won-Door FireGuard Stock Door

## HEAD DETAIL

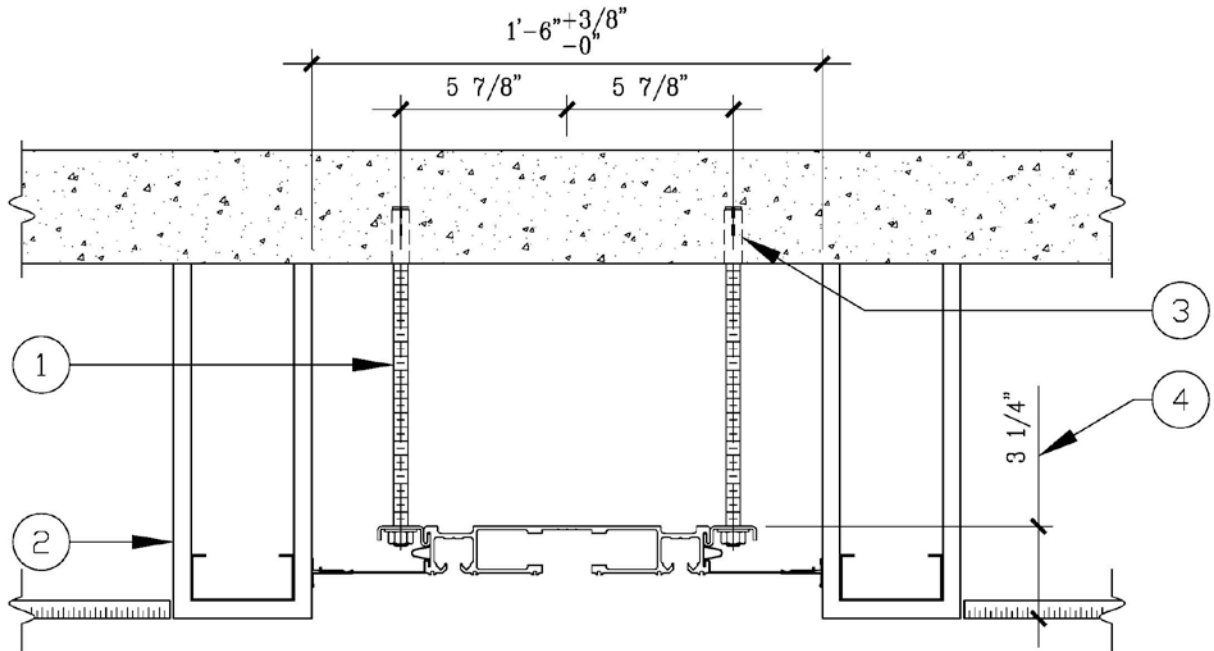

**UNITIZED TRACK SYSTEM**  
CAD FILE: SDHD1

1. 1/2" threaded rods, Unitized Track System by Won-Door.
2. Provide rated construction on each side corresponding to rating required for opening by others. (Note: 1 hour condition shown. To view additional rated conditions, visit our website @ [www.wondoors.com](http://www.wondoors.com))
3. Structural support or anchorage by others. Structural support is not limited to concrete deck.
4. Minimum dimension required to meet U.L. compliance. The dimension may be increased to further recess the head condition if required



# Won-Door FireGuard Stock Door

## PLAN VIEW - SLIM DRIVE

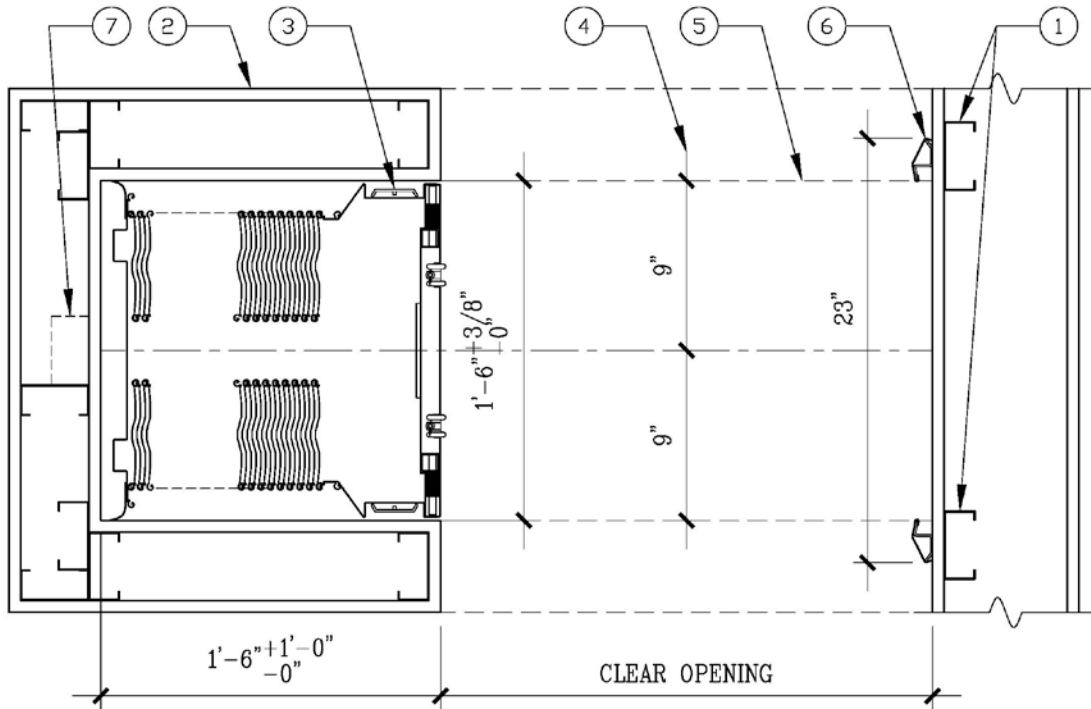

### **SINGLE PARTING**

CAD FILE: SDPL1

1. Continuous blocking by others.
2. Provide rated construction on each side corresponding to rating required for opening by others. (Note: 1 hour condition shown. To view additional rated conditions, visit our website @ [www.wondoor.com](http://www.wondoor.com))
3. Exit Devices. (meets all IBC Chapter 10 egress requirements)
4. Maintain 9" clearance on each side of the centerline of the door.
5. Fire rated bulkhead above, drop or flush with ceiling.
6. (2) 2 3/8" x 1 1/2" striker jambs by Won-Door. If recessed, provide 24" x 1 5/8" clearance. Finish wall to top of finished floor-no base or molding material allowed.
7. Two 4" x 4" junction boxes recess mounted 12" below top of track, centered on back wall of pocket for required electrical connections.

# Won-Door FireGuard Stock Door

## ELEVATION SIDE VIEW SLIM DRIVE

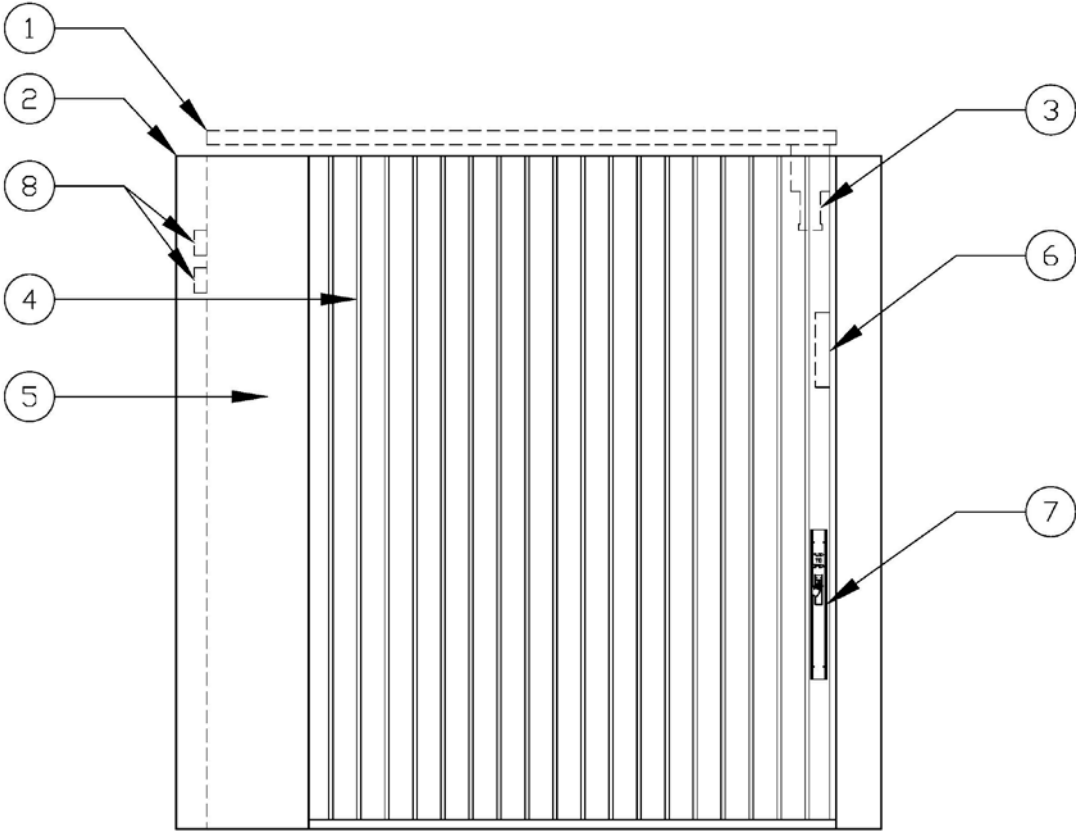

**SLIM DRIVE MOTOR OPERATOR**  
CAD FILE: FGCCELEV2

- 1. Top of door track. (Fabrication height.)
- 2. Ceiling line.
- 3. Motor operator assembly. (self-contained within lead post)
- 4. Folding fire door by Won-Door.
- 5. Storage pocket.
- 6. Electronic control box by Won-Door. (self-contained within lead post)
- 7. Fire exit devices mounted 36" A.F.F. (meets all IBC Chapter 10 egress requirements)
- 8. Two 4" x 4" junction boxes recess mounted 12" below top of track, centered on back wall of pocket for required electrical connections.



# Won-Door FireGuard Stock Door

## ELEVATION FRONT VIEW

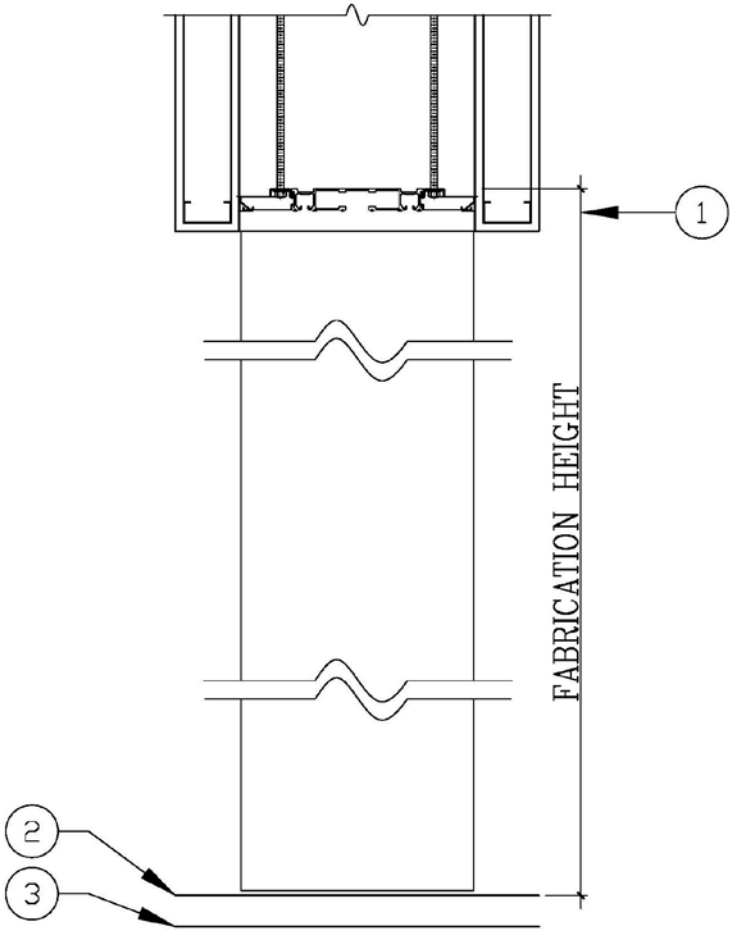

**STRAIGHT DOOR**  
CAD FILE: FGUTELEV3

1. Fabrication height/field dimension height taken from top of track to top of finished floor.
2. Finished floor. (Carpet, tile, etc.)
3. Sub floor. (Concrete, etc.)

- Door Profile Widths:
- Stacked Width: 14"
  - Extended Width: 9"

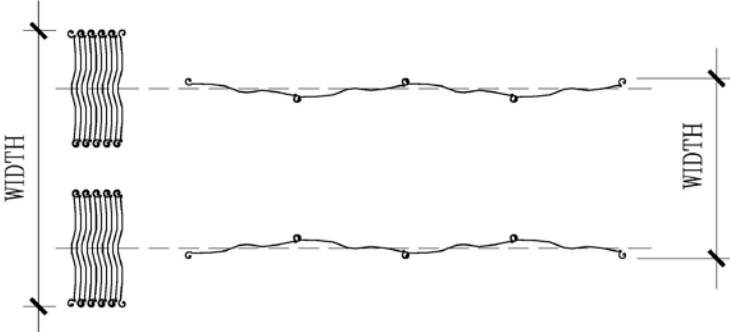

# Won-Door FireGuard Stock Door

## SLIM DRIVE MOTOR OPERATOR ELECTRICAL DIAGRAM

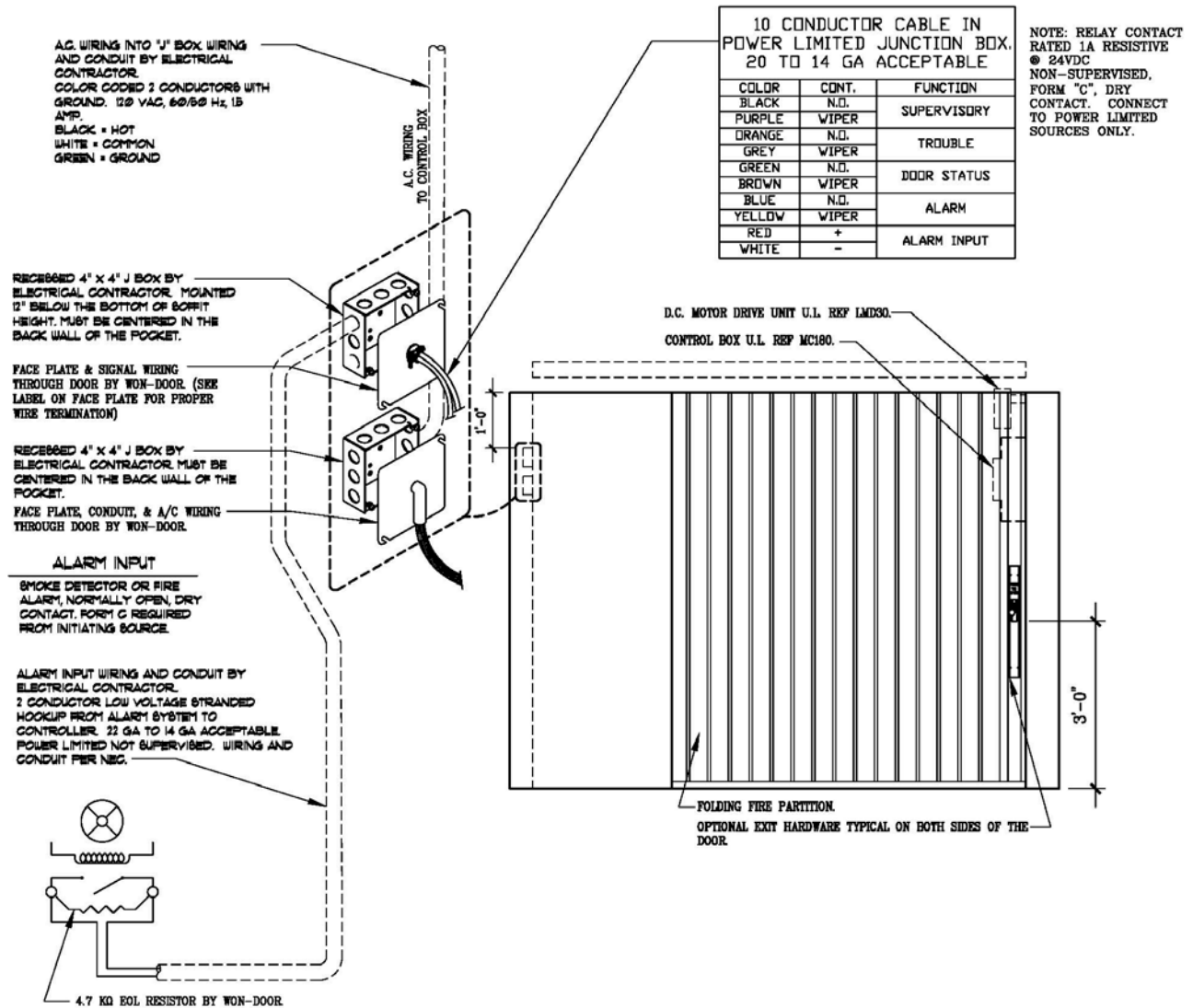

Note: Cable lengths referred to in this detail are actual cable lengths, not straight line distances. If cable length exceeds 25 wire feet, consult the factory.



# Won-Door FireGuard Stock Door

## CCOM ROCKER SWITCH

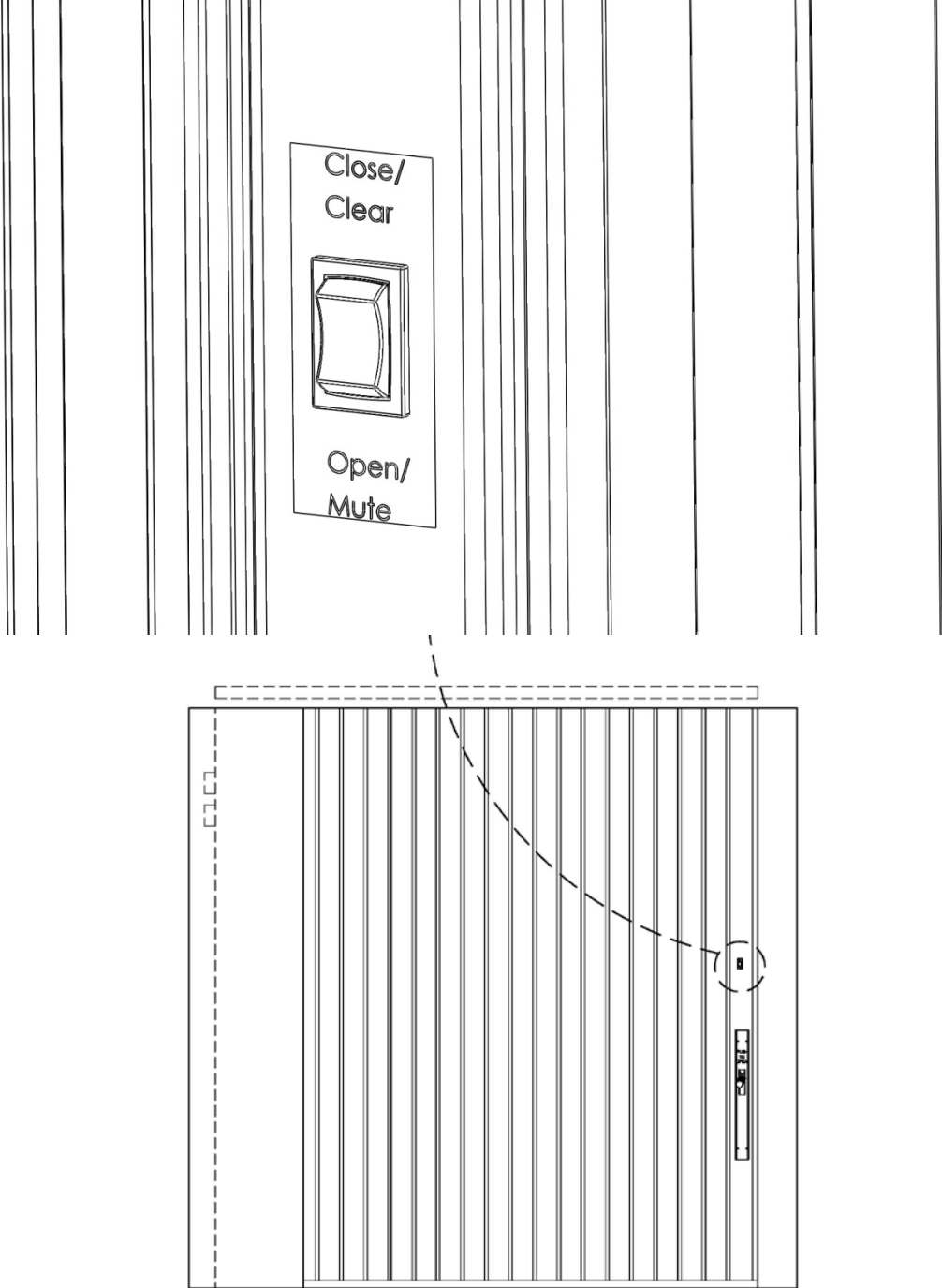

The CCOM switch is used to open and close the door and to reset and silence door faults.

# Won-Door FireGuard CC

## GUIDELINES FOR FIREGUARD CROSS CORRIDOR (CC)

**Won-Door FireGuard Cross Corridor (CC)** doors reduce storage pocket depths by up to 50% and include a flat lead post that eliminates the need for a custom made pocket cover door. FireGuard CC doors are single-parting and limited to a maximum width of 12'-0" and a maximum height of 10'-3 ¼". They are not available in bi-parting or curved configurations.

This section includes a Specification, details, and a Pocket Depth Calculation chart that apply specifically to the FireGuard CC fire door.



# Won-Door FireGuard CC

This page intentionally left blank.





# Won-Door FireGuard CC

## SECTION 08 35 13.23 – ACCORDION FOLDING FIRE DOORS

### PART 1 – GENERAL

#### 1.01 SUMMARY OF WORK

- A. Division 0 and 1, as indexed, apply to this section.
- B. Furnish and install all horizontal sliding, accordion folding fire doors shown on the drawings and specified herein.

#### 1.02 RELATED SECTIONS

- A. All headers, support structures, fire protection of support structures, surrounding insulation, jambs, storage pockets, blocking and trim shall be furnished and installed by other sections.
- B. All electrical wire, wiring, conduit and electrical boxes shall be furnished and installed by electrical section.
- C. Drilling/placement of anchorage points into pre or post tensioned decks, welding/punching/drilling steel members and all drywall work.
- D. **OPTION:** All track, soffit, chain guide and wall mounted striker pieces and integrated pocket cover door surface shall be painted by Section 09900. Color shall be selected by the architect.
- E. **OPTION:** *If Section 2.03 I, Individual LCD Door Status Display, is selected as an option, the following paragraph should be included:* Wiring for Individual LCD Door Status Display at fire door-One (1) USOC RJ14-6POS 4 wire jack shall be supplied at the back of the storage pocket and shall be tied to the 4 square junction box adjacent to the door with CAT 5 twisted 2 pair cable. The junction box, RJ14 jack and wire shall be furnished and installed by the electrical section. Termination to the LCD panel shall be by punch down block and shall be by the electrical section as per the manufacturer's instructions.

#### 1.03 QUALITY ASSURANCE

- A. Installation shall be performed by factory trained and certified installers with a minimum of three years experience installing electrically operated accordion folding fire doors.
- B. Fire doors shall be listed by Underwriters Laboratories for ratings as indicated, when tested in accordance with the requirements of UL 10B NFPA 252.
- C. Automatic closing system shall be listed by Underwriters Laboratories in accordance with the requirements of UL 864 and be listed for use with the assembly in compliance with NFPA 80, Chapter 9.
- D. Fire doors used for smoke and draft control shall bear the "S" mark on the fire door label and shall have an air leakage of less than  $3 \text{ ft}^3/\text{ft}^2$  at 0.1 inch of water column pressure when tested in accordance with UL 1784 with an artificial bottom seal.
- E. Fire doors used at the point of access to an elevator shall bear the "SE" mark on the fire door label and shall have an air leakage of less than  $3 \text{ ft}^3/\text{ft}^2$  at 0.1 inch of water column pressure when tested in accordance with UL 1784 without an artificial bottom seal.
- F. Fire Doors shall be capable of resisting an air pressure differential up to 0.05 inches of water column. Air pressure resistance to 0.1 inches of water column available. (*See Section 2.03 J*)

#### 1.04 SUBMITTALS

- A. See Section 01 30 00 – Administrative Requirements, for submittal procedures.
- B. Product Data: Provide manufacturer's technical literature, include UL listing data.



# Won-Door FireGuard CC

- C. Shop Drawings: Indicate construction and installation details and dimensions, including layout, electrical requirements, required stack depth, height of header above finished floor, and requirements for anchorage and support of each door.
- D. Operation and Maintenance Data: Operating procedures, troubleshooting and repair methods, and wiring diagrams.

## 1.05 DELIVERY, STORAGE, AND HANDLING

- A. Deliver to the job site in manufacturer's original, unopened package, labeled to show name, brand and type.
- B. Store products in a protected dry location. Replace damaged materials on-site at no cost to owner.

## 1.06 COORDINATION BY GENERAL CONTRACTOR

- A. Coordinate with the following:
  - 1. Fire Alarm system.
  - 2. Electrical.
  - 3. Panel pocket doors finish and wood veneer paneling (if applicable).
  - 4. Floor and ceiling finish.
- B. Assure accurate installation of header, jamb, and trim. Provide "As-Built" dimensions for opening and storage pocket. Supervise unloading and handling of materials.
- C. Store boxes flat (not more than three high) in a protected dry area. Replace damaged materials at no cost to owner.
- D. Permanent power shall be in-place and ready for final connection when fire doors are installed. Assure access to and proper clearance for motor operators.
- E. After testing the fire alarm system, automatic-closing fire doors shall be re-set to the original position.

## 1.07 WARRANTY

- A. Materials and installation shall be warranted against defects in workmanship for a period of one (1) year from the date of substantial completion.

## PART 2 – PRODUCTS

### 2.01 MANUFACTURERS

- A. Horizontal sliding accordion folding fire doors shall be Won-Door FireGuard Cross Corridor model FG-CC\_\_\_\_ (select one: 20, 60, or 90 – number designates minutes of fire rating) as manufactured by Won-Door Corporation, Salt Lake City, UT.
- B. Products of other manufacturers demonstrating complete compliance with each of the fire rating and performance criteria of the product specified will be considered for approval. Written requests for substitutions will be considered by the architect up to ten days prior to the bid date.
- C. **OPTION:** No substitutions allowed.



# Won-Door FireGuard CC

## 2.02 ACCORDION FIRE DOORS – GENERAL

- A. Provide electrically powered self-closing fire doors of configurations indicated on the drawings.
  - 1. Fire rating as required.
- B. Fire Rating – Fire doors shall be listed by Underwriters Laboratory as special purpose fire doors having a (*select one: 20, 60, or 90*) minute fire-resistive rating in accordance with the requirements of UL 10B and NFPA 252.
- C. Closing and Opening Operation: Automatic Closing System including motor operator and releasing devices shall be a Microprocessor-based system rated to UL864 (Releasing Device Control Unit) and shall commence closing upon activation by fire alarm system and/or by low battery charge.
  - 1. Obstruction Detection: Contact with an obstruction shall cause the door to stop, reverse enough to remove pressure on the leading edge, pause, and then re-close when in an alarm condition.
  - 2. While the door is opening under motor power, constant pressure to the leading edge in the direction of opening shall cause the door to continue to open until the leading edge is released. This is termed motor-assisted opening.
  - 3. Constant pressure to the leading edge while not under motor power shall prevent motor operation and allow the door to be opened manually.
- D. Exit Devices Operation: Provide fire exit devices on both sides of door.
  - 1. In emergency mode, a slight pressure on the device will cause the door to open a minimum of 32 inches, pause for 3 seconds, and then automatically close.
  - 2. The open distance shall be field programmable, up to the entire opening width, if the local authority requires an opening larger than 32 inches.
  - 3. The pause before re-close shall be field programmable, up to 30 seconds, if the local authority requires a longer pause time.
  - 4. The exit device shall have the ability when not in the emergency (fire) mode to be used to open the door and move it back into the storage pocket.
  - 5. **OPTION:** *If Section 2.03 H, Access Control, is selected as an option, the following paragraph should be included:* The exit device shall be field programmable to provide access control. When programmed, the exit device shall not respond when pressed until activated by signal from smoke detector or fire alarm.

## 2.03 COMPONENTS

- A. Door Construction: Two parallel, accordion-type walls independently suspended with no floor tracks, pantographs, or interconnections.
  - 1. Panels: 24 gauge steel, V-grooved; modular in design; capable of in-place repair.
  - 2. Perimeter Seals: shall consist of continuous extruded vinyl sweeps attached to the top and bottom of the fire door to form a smoke and draft seal.
  - 3. Hanging Weight: 5.5 pounds per sq. ft. when extended across opening.
  - 4. Finish: All steel parts factory-applied enamel.
  - 5. Color: Manufacturer's standard platinum.



# Won-Door FireGuard CC

- B. Suspension System: Two tracks, on 8 inch centers, attached to overhead structural support.
  - 1. Tracks: .125 aluminum.
  - 2. Panel Hangers: Every other panel is suspended by a steel hanger pin and ball bearing roller.
  - 3. Lead Post Hangers: 16-gauge steel structural tube frame with 18-gauge steel preformed cover. The lead post shall function as an integrated cover panel over the storage pocket opening when the fire door is in the open position.
- C. Power Supply: 12-volt maintenance-free DC battery, automatically maintained at capacity by continuous charger, 120 V AC.
- D. Automatic Closing System shall be listed to UL864 including capability to send and receive signals from the Fire Control Panel, and shall consist of the following:
  - 1. Microprocessor based Electronic Control box with the ability to:
    - a. Monitor dual power sources continually for peak performance including:
      - 1) Detect a missing battery, bad battery, or low battery condition.
      - 2) Detect if the charging circuit is bad.
      - 3) Detect fuse failures.
      - 4) Detect high or low AC conditions.
    - b. Monitor the health of the drive train.
    - c. Monitor inputs including: sticky door block, exit devices, patron devices, and key switches.
    - d. Run a “watch dog” monitoring circuit which will force a software restart in the event the software hangs, including tracking the number of resets that occur for diagnostic purposes.
    - e. Withstand voltages up to 120 volts AC on the fire alarm input circuit without damage including the ability to indicate that the alarm circuit has not been wired as a dry contact, “no voltage” circuit when errant voltages are applied to the circuit.
    - f. Communicate with other microprocessors on the system via an internal buss system.
    - g. Indicate faults or supervised information both locally and at a remote location.
  - 2. Motor Operator Assembly including a DC gear-motor, drive sprocket, clutch, and position sensors. The motor shall drive the fire door by means of a chain attached to a stabilizer bar trolley. The motor shall be rated for continuous use with unlimited cycle duty.
  - 3. If a key switch (*NOTE: Section 2.03 G*) is NOT used, A door control momentary rocker switch shall be mounted on one side of the door and shall function as follows:
    - a. Pressing the upper portion shall close the door and/or clear fault conditions.
    - b. Pressing the lower portion of the switch shall open the door and/or temporarily mute the local horn.



# Won-Door FireGuard CC

4. Leading Edge Obstruction Detector shall be pressure sensitive such that contact with an obstruction shall cause the door to stop, pause for 3 seconds, then re-close when in alarm mode. The obstruction detection system shall be fully functional at all times.
5. Exit Devices will be located on both sides of each fire door.
- E. The header shall be eliminated because of the Unitized Track System. Self-supporting track, threaded rods and mechanical attachment hardware are included.
- F. **OPTION:** Vision Panel located at the leadpost consisting of a frame and clear glass assembly with listings from Underwriters Laboratory up to 90 minutes.
- G. **OPTION:** A Key Switch shall be provided, located as directed by the Architect. (*Note: required with door equipped with Access Control option*)
- H. **OPTION:** Access Control: The Exit Devices shall not respond when pressed until activated/over-ridden by signal from smoke detector or fire alarm. A rigid jamb stop and key switch shall be provided for authorized operation of the door assembly. A signal from the smoke detector or fire alarm will automatically override the access control feature. (*Note: at least one key-switch required.*)
- I. **OPTION:** A Individual LCD Door Status Display panel shall be provided adjacent to the door to indicate in the English language the status of the door, i.e. door position and trouble conditions (*Note: Electrical requirements for the Individual LCD Door Status Display panel can be found in Section 1.02 E*)
- J. **OPTION:** Air Pressure Resistance. The door shall be capable of resisting an air pressure differential to 0.1 inches water column with the addition of anti-sway brackets placed interior to the door.

## 2.04 RELATED CONSTRUCTION

- A. Track Support Construction: Provide supports attached to structure and mounting surface for track including drilling/placement of anchorage points into pre or post tensioned decks, welding/punching/drilling steel members, and all drywall work; comply with door manufacturer's instructions and recommendations.
- B. Pocket Construction: Provide pocket for concealment of accordion door when open; comply with door manufacturer's instructions and recommendations.

## PART 3 – EXECUTION

### 3.01 EXAMINATION

- A. Verify that adjacent construction is suitable for installation of door.
- B. Verify that electrical utilities have been installed and are accessible.
- C. Verify that door opening is plumb and header is level and of correct dimensions.
- D. Notify Architect of any unacceptable conditions or varying dimensions.

### 3.02 INSTALLATION

- A. Install in accordance with manufacturer's instructions, shop drawings and NFPA 80.
- B. Install fire doors parallel with the finished floor.



# Won-Door FireGuard CC

## 3.03 ADJUSTING

- A. Adjust door installation to provide uniform clearances and smooth, quiet, non-binding operation.
- B. Test that all operations are functional and meet the requirements of local codes.

## 3.04 CLEANING

- A. Clean surfaces using manufacturer's recommended means and methods.

## 3.05 PROTECTION

- B. Protect installed work from damage.

## 3.06 STORAGE OF WASTE AND RECYCLING

- A. Store and recycle waste in accordance with Section 01 74 19 Construction Waste Management and Disposal.

Copyright © 2013 by Won-Door Corporation, all rights reserved.  
END OF SECTION



# Won-Door FireGuard CC

## HEAD DETAIL

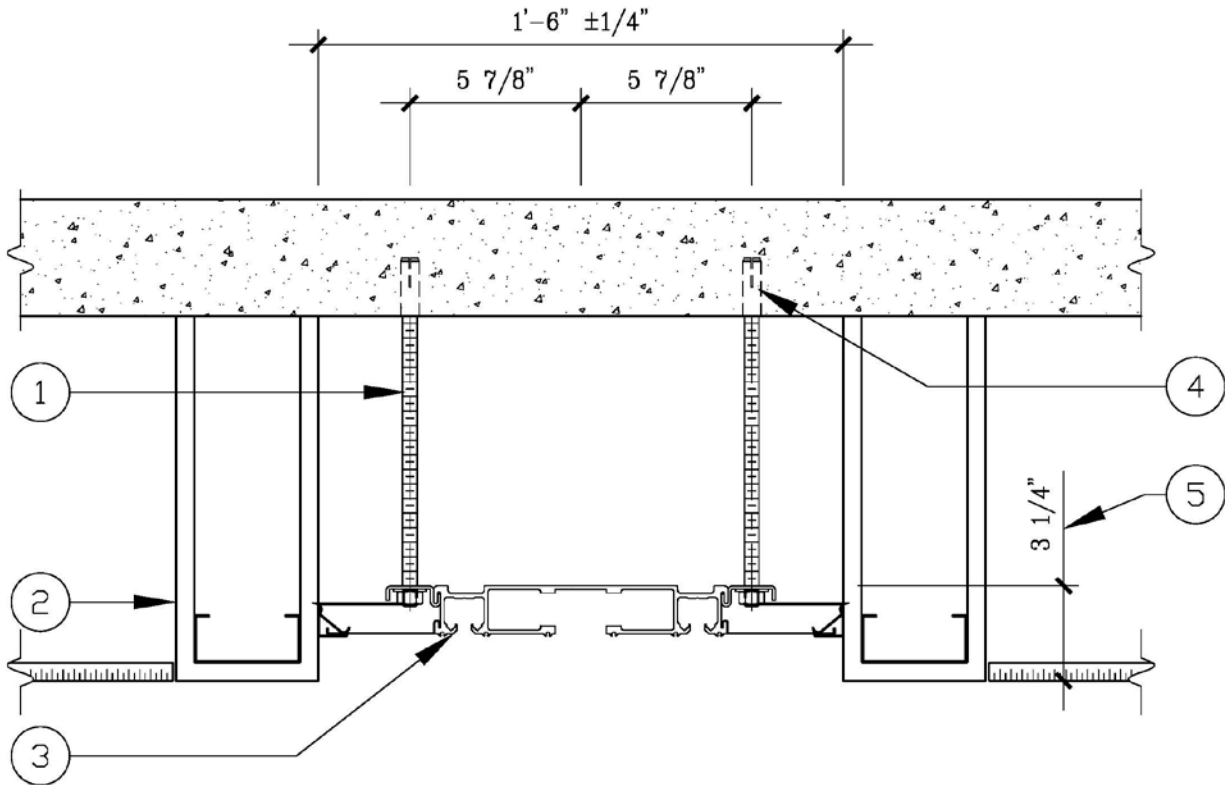

### **STANDARD HEAD**

CAD FILE: UTFGHD1

1. 1/2" dia. threaded rod with nuts and washers by Won-Door. (12" from each end and 24" O.C. across opening.)
2. Provide rated construction on each side corresponding to rating required for opening by others. (Note: 1 hour condition shown. To view additional rated conditions, visit our website @ [www.wondoor.com](http://www.wondoor.com))
3. Pre-finished white track and soffit assembly by Won-Door.
4. Structural support or anchorage by others. Structural support is not limited to concrete deck.
5. Minimum dimension required to meet U.L. compliance. The dimension may be increased to further recess the head condition if required.



# Won-Door FireGuard CC

## PLAN VIEW - SLIM DRIVE

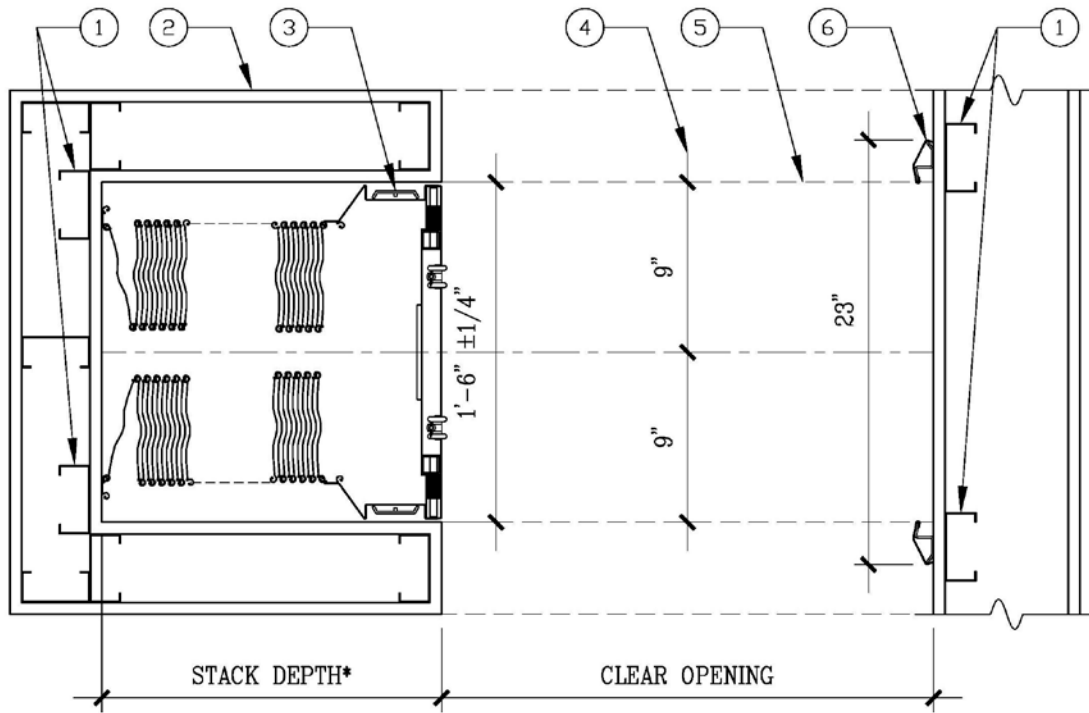

### **SINGLE PARTING**

CAD FILE: FGCCPL1

1. Continuous blocking by others.
2. Provide rated construction on each side corresponding to rating required for opening by others. (Note: 1 hour condition shown. To view additional rated conditions, visit our website @ [www.wondoors.com](http://www.wondoors.com))
3. Exit Devices. (meets all IBC Chapter 10 egress requirements)
4. Maintain 9" clearance on each side of the centerline of the door.
5. Fire rated bulkhead above, drop or flush with ceiling.
6. (2) 2 3/8" x 1 1/2" striker jambs by Won-Door. If recessed, provide 24" x 1 5/8" clearance. Finish wall to top of finished floor-no base or molding material allowed.
7. U.L. listed integrated cover door by Won-Door.

Specifier's  
note

\*To determine pocket depth, see the *Instructions* on page 63 and *Pocket Depth Calculation Chart* on page 64.



# Won-Door FireGuard CC

## ELEVATION SIDE VIEW SLIM DRIVE

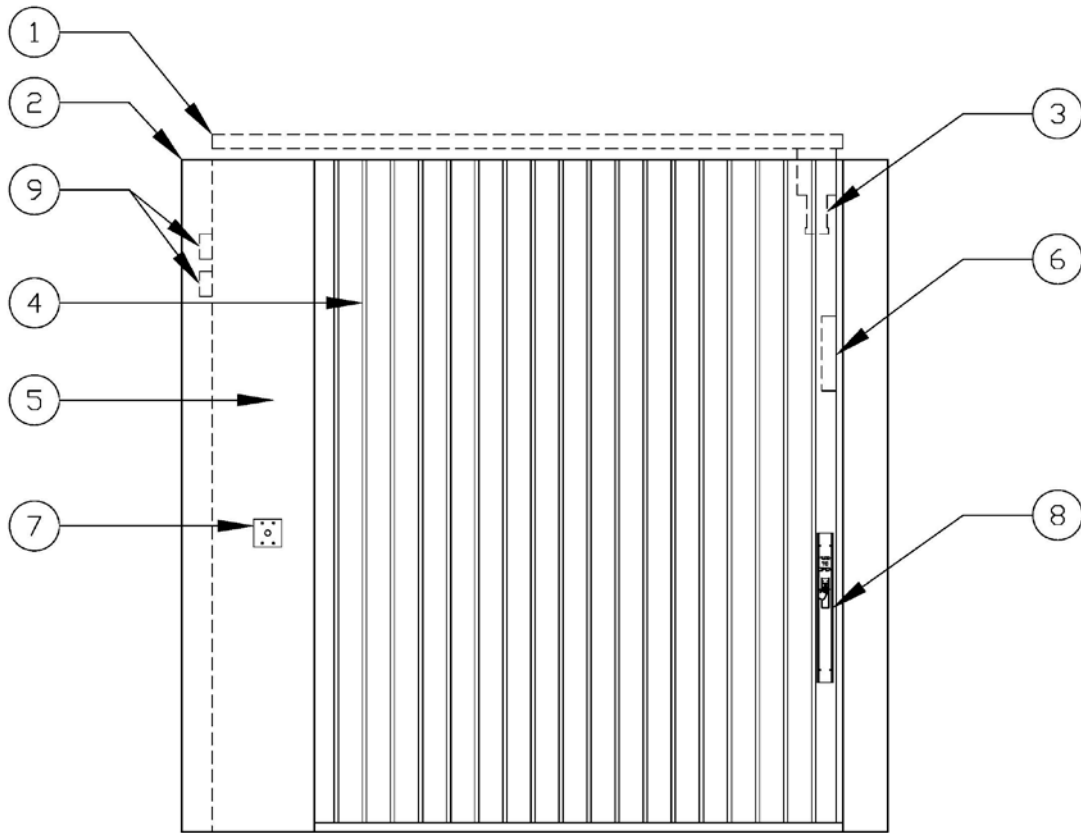

### **SLIM DRIVE MOTOR OPERATOR**

CAD FILE: FGCCELEV2

1. Top of door track. (Fabrication height.)
2. Ceiling line.
3. Motor operator assembly. (self-contained within lead post)
4. Folding fire door by Won-Door.
5. Storage pocket.
6. Electronic control box by Won-Door. (self-contained within lead post)
7. [Optional key switch by Won-Door. (See page 66.)
8. Fire exit devices mounted 36" A.F.F. (meets all IBC Chapter 10 egress requirements)
9. Two 4" x 4" junction boxes recess mounted 12" below top of track, centered on back wall of pocket for required electrical connections.



Brackets [ ] indicate specifier's option



# Won-Door FireGuard CC

## ELEVATION FRONT VIEW

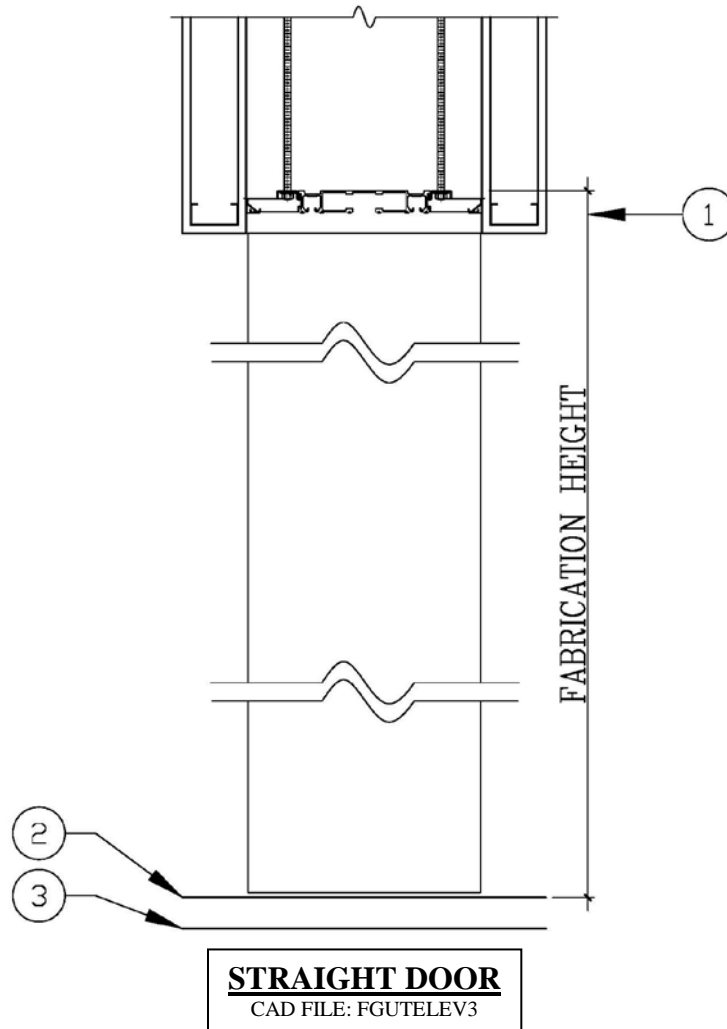

1. Fabrication height/field dimension height taken from top of track to top of finished floor.
2. Finished floor. (Carpet, tile, etc.)
3. Sub floor. (Concrete, etc.)

### Door Profile Widths:

- Stacked Width: 14"
- Extended Width: 9"

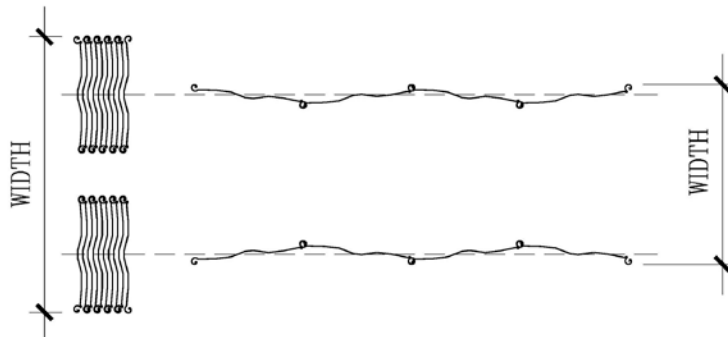

# Won-Door FireGuard CC

## POCKET DEPTH CHART INSTRUCTIONS

The term CLEAR OPENING WIDTH on the *Pocket Depth Calculation Chart* refers to the distance from the front of the storage pocket to face of the striker.

To determine the pocket depth requirement of a door:

1. Determine the door's CLEAR OPENING WIDTH
2. Find the appropriate range for that width (*From-To* columns)
4. Consult the *Options Affecting Pocket Depth* section below the chart to determine how optional equipment affects stack requirements.

**Example below:** Pocket depth for FireGuard CC single parting door w/ 10'-5" clear opening (in the range from 9'-10" to 10'-7"). Minimum pocket depth = 1'-8".

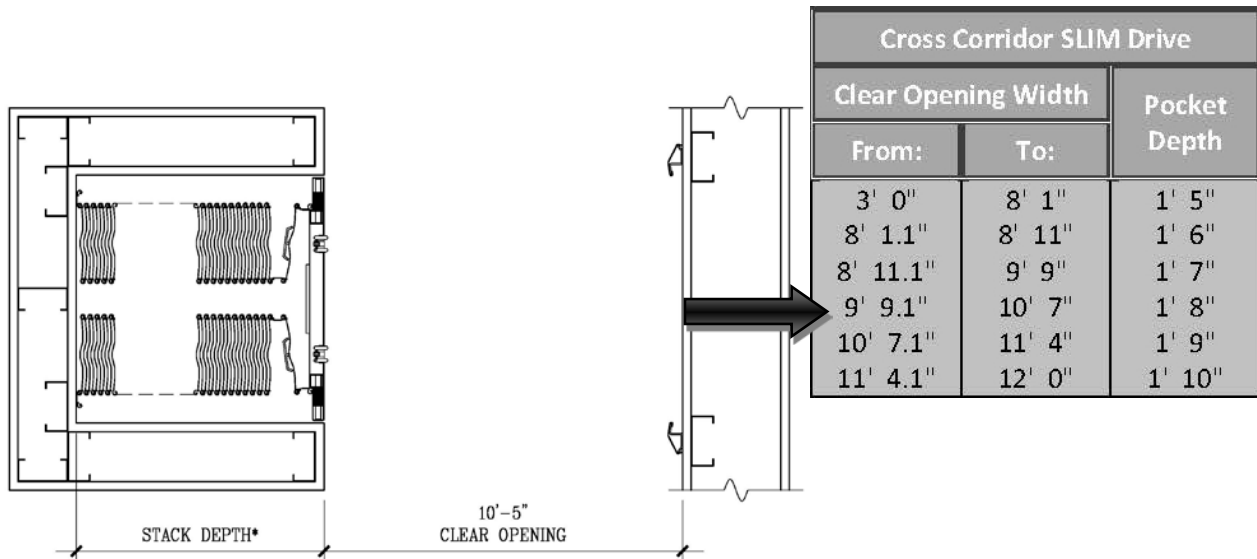

### List of Options Affecting Pocket Depth

- Security: Add 1" to the stack depth.



# Won-Door FireGuard CC

## POCKET DEPTH CALCULATION CHART FireGuard CC

Clear Opening Width		Pocket Depth
		SLIM DRIVE
From:	To:	
0'-0"	8'-0"	1'-6"
8'-0"	8'-10"	1'-7"
8'-10"	10'-7"	1'-8"
10'-7"	11'-6"	1'-9"
11'-6"	12'-0"	1'-10"

### Limitations and Considerations

1. Size: Maximum height is 10'-3 1/4" to the top of track (ceiling height = 10'-0"). Maximum width is 12'-0".
2. Fire Rating: Fire ratings up to 1 1/2 hours are available.
3. Security: Level 1 is the maximum allowed.
4. Vision panels: One vision panel is the maximum allowed. Additional vision panels are not available.
5. Fire Exit Devices: One set of exit devices is included. Additional exit devices are not available.
6. Air Pressure Resistance: Maximum of 0.1" W.C. is allowed.(additional equipment is required)
7. Smoke Rating: S or SE ratings are available.
8. Bi-Part: Not available.
9. Curves: Not available.
10. Temperature Rise: Not available.
11. Moveable Fire Wall: Not available.



# Won-Door FireGuard CC

## SLIM DRIVE MOTOR OPERATOR ELECTRICAL DIAGRAM

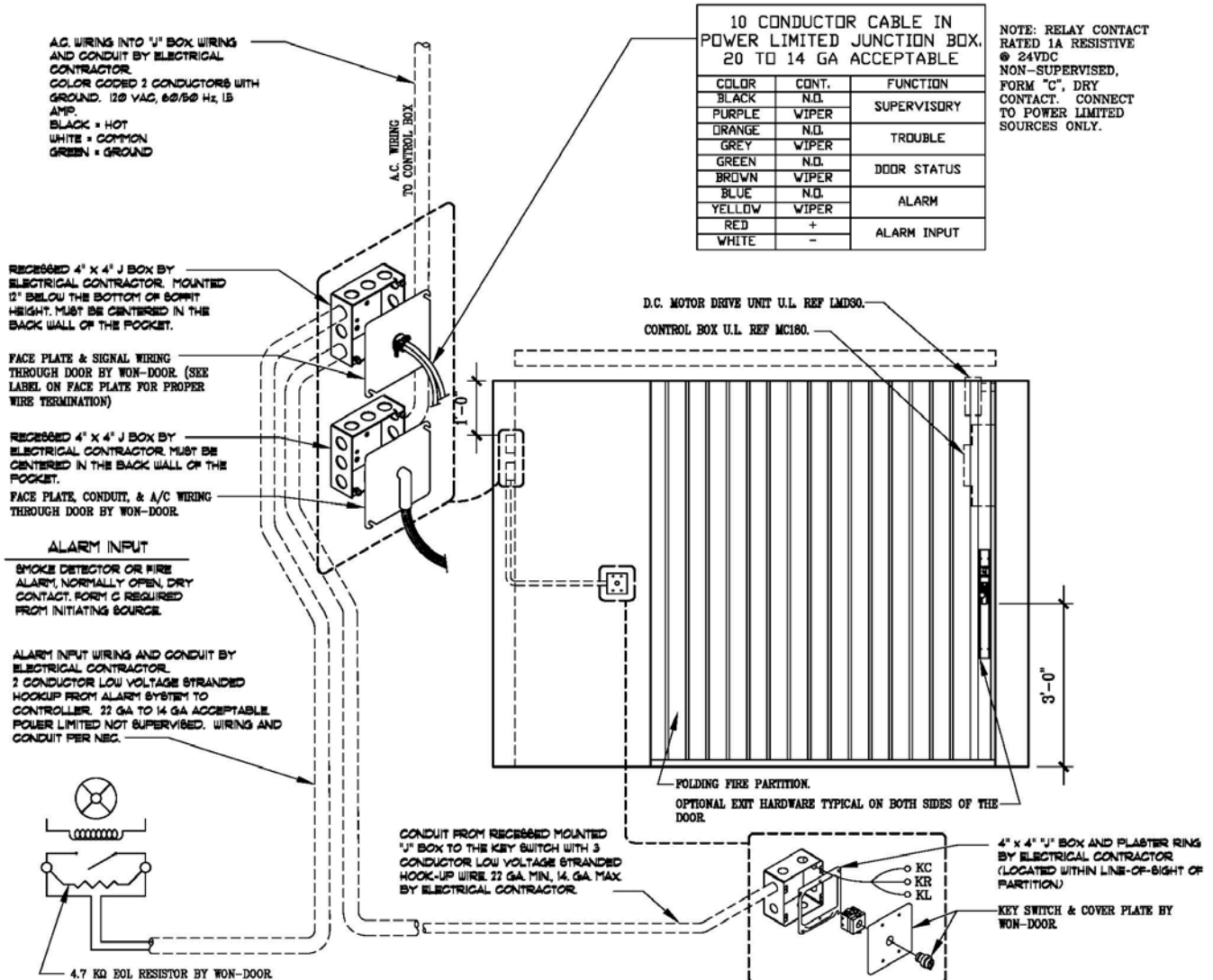

Note: Cable lengths referred to in this detail are actual cable lengths, not straight line distances. If cable length exceeds 25 wire feet, consult the factory.  
Key switch is required with access control.



# Won-Door FireGuard CC

## OPTIONAL KEY SWITCH

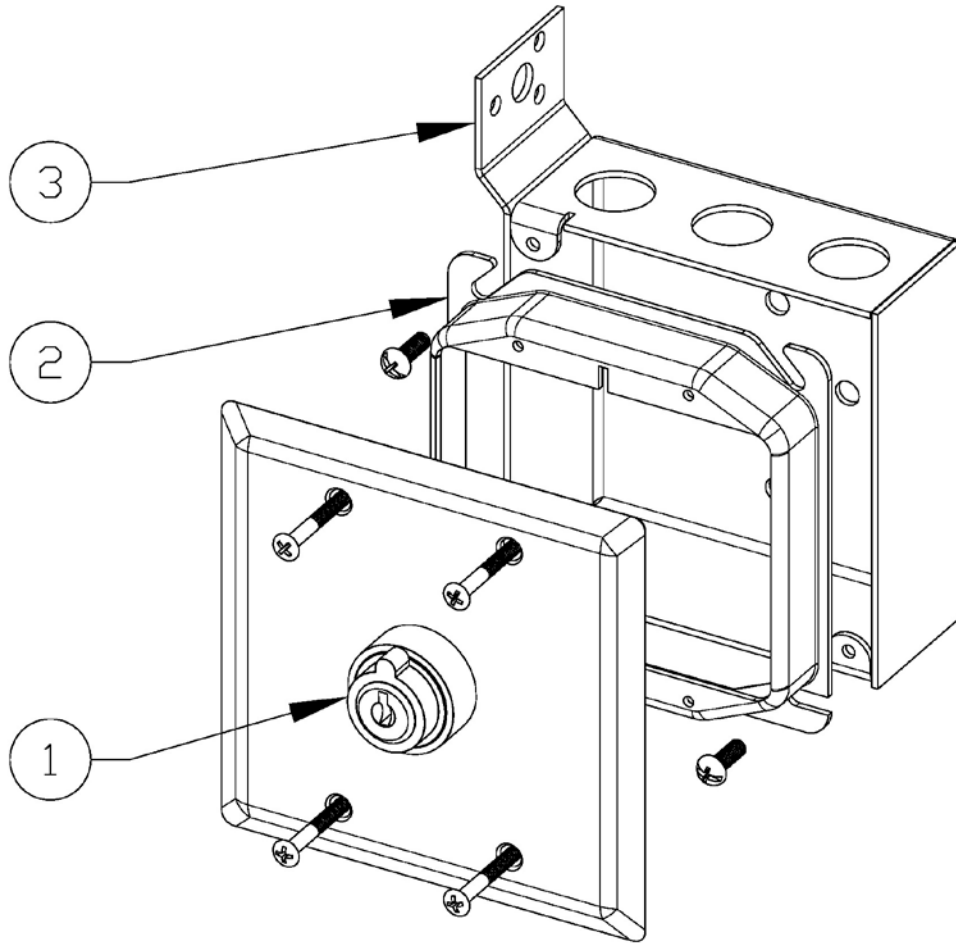

1. Key switch module.
2. Plaster ring by others.
3. 4" x 4" x 2 1/2" electrical box by others.

Key switches are *optional* except for the following application:

1. Access control options.

For safety reasons, a key switch must be installed within line-of-sight of the operation of the Won-Door FireGuard door.

Specifier's  
note



# Won-Door FireGuard CC

## CCOM ROCKER SWITCH

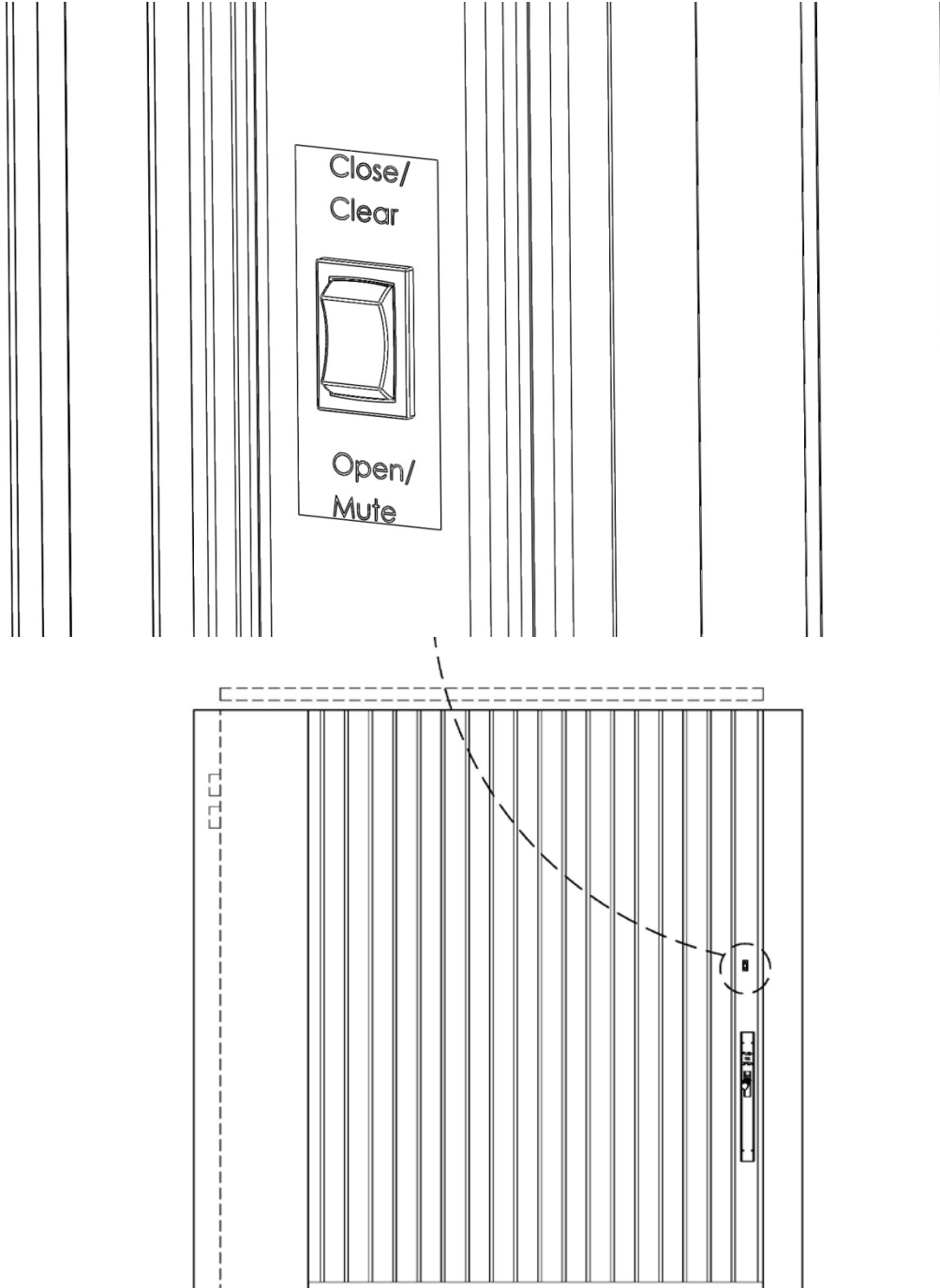

Specifier's  
note

CCOM rocker switch is included when a key switch is not specified. The switch is used to open and close the door and to reset and silence door faults.



# Won-Door FireGuard CC

## OPTIONAL VISION PANEL

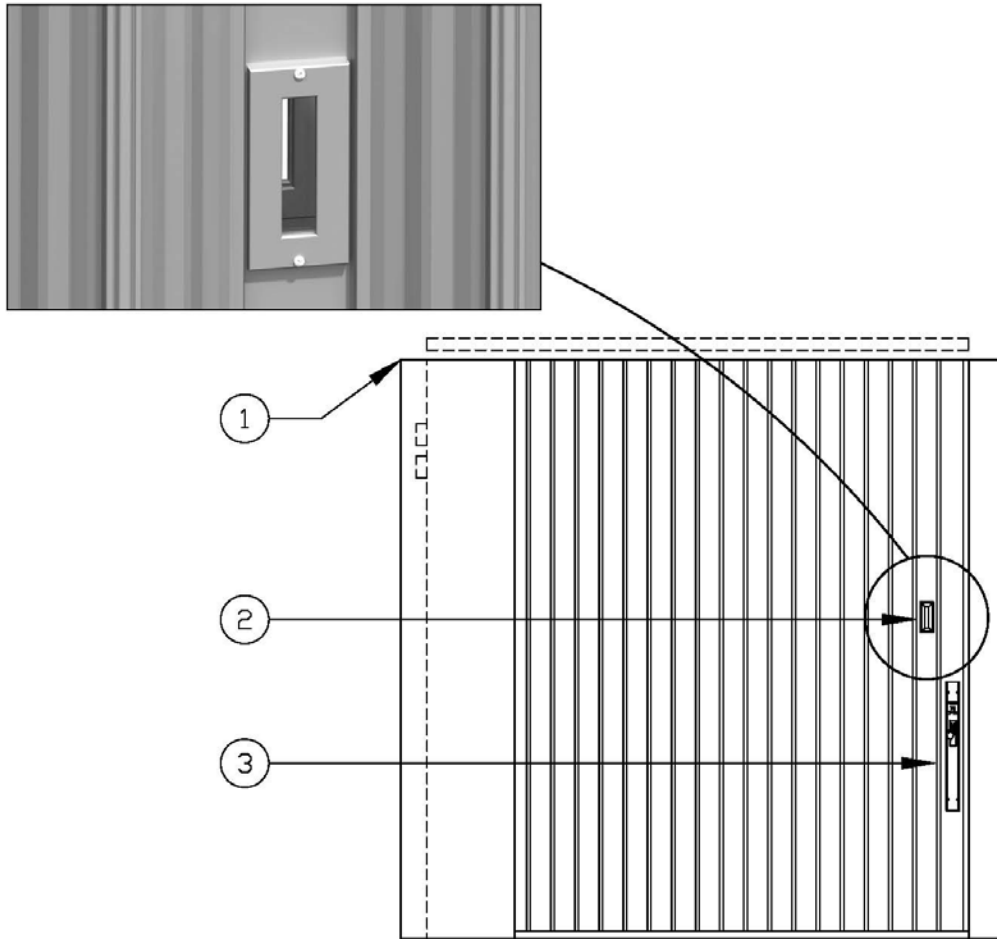

1. Ceiling line.
2. 1 1/2-hour U.L. listed Vision Panel. Required only for smoke barrier applications in Group I occupancies. Maximum size is 5 3/4" x 2 5/8".
3. Exit devices.



# Won-Door FireGuard CS

## GUIDELINES FOR FIREGUARD COMPRESSED STACK (CS)

**Won-Door FireGuard Compressed Stack (CS)** doors reduce storage pocket depths by up to 50% and include a flat lead post that eliminates the need for a custom made pocket cover door. FireGuard CS doors are single parting and are limited to a maximum length of 30'-0" and a maximum height 12'-3/4". They are not available in bi-parting or curved configurations.

This section includes a Specification and a Pocket Depth Calculation chart that apply specifically to Won-Door FireGuard Compressed Stack (CS)



# Won-Door FireGuard CS

This page intentionally left blank.



# Won-Door FireGuard CS

## SECTION 08 35 13.23 – ACCORDION FOLDING FIRE DOORS

### PART 1 – GENERAL

#### 1.01 SUMMARY OF WORK

- A. Division 0 and 1, as indexed, apply to this section.
- B. Furnish and install all horizontal sliding, accordion folding fire doors shown on the drawings and specified herein.

#### 1.02 RELATED SECTIONS

- A. All headers, support structures, fire protection of support structures, surrounding insulation, jambs, storage pockets, blocking and trim shall be furnished and installed by other sections.
- B. All electrical wire, wiring, conduit and electrical boxes shall be furnished and installed by electrical section including connections to smoke detectors and building fire alarm panels.
- C. Drilling/placement of anchorage points into pre or post tensioned decks, welding/punching/drilling steel members and all drywall work.
- D. **OPTION:** All track, soffit, chain guide and wall mounted striker pieces and integrated pocket cover door surface shall be painted by Section 09900. Color shall be selected by the architect.
- E. **OPTION:** *If Section 2.03 I, Individual LCD Door Status Display, is selected as an option, the following paragraph should be included:* Wiring for Individual LCD Door Status Display at fire door-One (1) USOC RJ14-6POS 4 wire jack shall be supplied at the back of the storage pocket and shall be tied to the 4 square junction box adjacent to the door with CAT 5 twisted 2 pair cable. The junction box, RJ14 jack and wire shall be furnished and installed by the electrical section. Termination to the LCD panel shall be by punch down block and shall be by the electrical section as per the manufacturer's instructions.

#### 1.03 QUALITY ASSURANCE

- A. Installation shall be performed by factory trained and certified installers with a minimum of three years experience installing electrically operated accordion folding fire doors.
- B. Fire doors shall be listed by Underwriters Laboratories for ratings as indicated, when tested in accordance with the requirements of UL 10B NFPA 252.
- C. Automatic closing system shall be listed by Underwriters Laboratories in accordance with the requirements of UL 864 and be listed for use with the assembly in compliance with NFPA 80, Chapter 9.
- D. Fire doors used for smoke and draft control shall bear the "S" mark on the fire door label and shall have an air leakage of less than  $3 \text{ ft}^3/\text{ft}^2$  at 0.1 inch of water column pressure when tested in accordance with UL 1784 with an artificial bottom seal.
- E. Fire doors used at the point of access to an elevator shall bear the "SE" mark on the fire door label and shall have an air leakage of less than  $3 \text{ ft}^3/\text{ft}^2$  at 0.1 inch of water column pressure when tested in accordance with UL 1784 without an artificial bottom seal.
- F. Fire Doors shall be capable of resisting an air pressure differential up to 0.05 inches of water column. Air pressure resistance to 0.1 inches of water column available. (See Section 2.03 J)

#### 1.04 SUBMITTALS

- A. See Section 01 30 00 – Administrative Requirements, for submittal procedures.
- B. Product Data: Provide manufacturer's technical literature, include UL listing data.



# Won-Door FireGuard CS

- C. Shop Drawings: Indicate construction and installation details and dimensions, including layout, electrical requirements, required stack depth, height of header above finished floor, and requirements for anchorage and support of each door.
- D. Operation and Maintenance Data: Operating procedures, troubleshooting and repair methods, and wiring diagrams.

## 1.05 DELIVERY, STORAGE, AND HANDLING

- A. Deliver to the job site in manufacturer's original, unopened package, labeled to show name, brand and type.
- B. Store products in a protected dry location. Replace damaged materials on-site at no cost to owner.

## 1.06 COORDINATION BY GENERAL CONTRACTOR

- A. Coordinate with the following:
  - 1. Fire Alarm system.
  - 2. Electrical.
  - 3. Panel pocket doors finish and wood veneer paneling (if applicable).
  - 4. Floor and ceiling finish.
- B. Assure accurate installation of header, jamb, and trim. Provide "As-Built" dimensions for opening and storage pocket. Supervise unloading and handling of materials.
- C. Store boxes flat (not more than three high) in a protected dry area. Replace damaged materials at no cost to owner.
- D. Permanent power shall be in-place and ready for final connection when fire doors are installed. Assure access to and proper clearance for motor operators.
- E. After testing the fire alarm system, automatic-closing fire doors shall be re-set to the original position.

## 1.07 WARRANTY

- A. Materials and installation shall be warranted against defects in workmanship for a period of one (1) year from the date of substantial completion.

## PART 2 – PRODUCTS

### 2.01 MANUFACTURERS

- A. Horizontal sliding accordion folding fire doors shall be Won-Door FireGuard Compressed Stack model FG-CS\_\_\_\_ (select one: 20, 60, 90 or 180 – number designates minutes of fire rating) as manufactured by Won-Door Corporation, Salt Lake City, UT.
- B. Products of other manufacturers demonstrating complete compliance with each of the fire rating and performance criteria of the product specified will be considered for approval. Written requests for substitutions will be considered by the architect up to ten days prior to the bid date.
- C. **OPTION:** No substitutions allowed.



# Won-Door FireGuard CS

## 2.02 ACCORDION FIRE DOORS – GENERAL

- A. Provide electrically powered self-closing fire doors of configurations indicated on the drawings.
  - 1. Fire rating as required.
- B. Fire Rating – Fire doors shall be listed by Underwriters Laboratory as special purpose fire doors having a (*select one: 20, 60, 90, or 180*) minute fire-resistive rating in accordance with the requirements of UL 10B and NFPA 252.
- C. Closing and Opening Operation: Automatic Closing System including motor operator and releasing devices shall be a Microprocessor-based system rated to UL864 (Releasing Device Control Unit) and shall commence closing upon activation by fire alarm system and/or by low battery charge.
  - 1. Obstruction Detection: Contact with an obstruction shall cause the door to stop, reverse enough to remove pressure on the leading edge, pause, and then re-close when in an alarm condition.
  - 2. While the door is opening under motor power, constant pressure to the leading edge in the direction of opening shall cause the door to continue to open until the leading edge is released. This is termed motor-assisted opening.
  - 3. Constant pressure to the leading edge while not under motor power shall prevent motor operation and allow the door to be opened manually.
- D. Exit Device Operation: Provide fire exit devices on both sides of door.
  - 1. In emergency mode, a slight pressure on the device will cause the door to open a minimum of 32 inches, pause for 3 seconds, and then automatically close.
  - 2. The open distance shall be field programmable, up to the entire opening width, if the local authority requires an opening larger than 32 inches.
  - 3. The pause before re-close shall be field programmable, up to 30 seconds, if the local authority requires a longer pause time.
  - 4. The exit device shall have the ability when not in the emergency (fire) mode to be used to open the door and move it back into the storage pocket.
  - 5. **OPTION:** *If Section 2.03 H, Access Control, is selected as an option, the following paragraph should be included:* The exit devices shall be field programmable to provide access control. When programmed, the exit device shall not respond when pressed until activated by signal from smoke detector or fire alarm.

## 2.03 COMPONENTS

- A. Door Construction: Two parallel, accordion-type walls independently suspended with no floor tracks, pantographs, or interconnections.
  - 1. Panels: 24 gauge steel, V-grooved; modular in design; capable of in-place repair.
  - 2. Perimeter Seals: shall consist of continuous extruded vinyl sweeps attached to the top and bottom of the fire door to form a smoke and draft seal.
  - 3. Hanging Weight: 5.5 pounds per sq. ft. when extended across opening.
  - 4. Finish: All steel parts factory-applied enamel.
  - 5. Color: Manufacturer's standard platinum.



# Won-Door FireGuard CS

- B. Suspension System: Two tracks, on 8 inch centers, attached to overhead structural support.
  - 1. Tracks: .125 aluminum.
  - 2. Panel Hangers: Every other panel is suspended by a steel hanger pin and ball bearing roller.
  - 3. Lead Post Hangers: 16-gauge steel structural tube frame with 18-gauge steel preformed cover. The lead post shall function as an integrated cover panel over the storage pocket opening when the fire door is in the open position.
- C. Power Supply: 12-volt maintenance-free DC battery, automatically maintained at capacity by continuous charger, 120 V AC.
- D. Automatic Closing System shall be listed to UL864 including capability to send and receive signals from the Fire Control Panel, and shall consist of the following:
  - 1. Microprocessor based Electronic Control box with the ability to:
    - a. Monitor dual power sources continually for peak performance including:
      - 1) Detect a missing battery, bad battery, or low battery condition.
      - 2) Detect if the charging circuit is bad.
      - 3) Detect fuse failures.
      - 4) Detect high or low AC conditions.
    - b. Monitor the health of the drive train.
    - c. Monitor inputs including: sticky door block, exit devices, patron devices, and key switches.
    - d. Run a “watch dog” monitoring circuit which will force a software restart in the event the software hangs, including tracking the number of resets that occur for diagnostic purposes.
    - e. Withstand voltages up to 120 volts AC on the fire alarm input circuit without damage including the ability to indicate that the alarm circuit has not been wired as a dry contact, “no voltage” circuit when errant voltages are applied to the circuit.
    - f. Communicate with other microprocessors on the system via an internal buss system.
    - g. Indicate faults or supervised information both locally and at a remote location.
  - 2. Motor Operator Assembly including a DC gear-motor, drive sprocket, clutch, and position sensors. The motor shall drive the fire door by means of a chain attached to a stabilizer bar trolley. The motor shall be rated for continuous use with unlimited cycle duty.
  - 3. If a key switch (**NOTE:** Section 2.03 G) is NOT used, A door control momentary rocker switch shall be mounted on one side of the door and shall function as follows:
    - a. Pressing the upper portion shall close the door and/or clear fault conditions.
    - b. Pressing the lower portion of the switch shall open the door and/or temporarily mute the local horn.



# Won-Door FireGuard CS

4. Leading Edge Obstruction Detector shall be pressure sensitive such that contact with an obstruction shall cause the door to stop, pause for 3 seconds, then re-close when in alarm mode. The obstruction detection system shall be fully functional at all times.
5. Exit Devices will be located on both sides of each fire door.
- E. The header shall be provided as an integrated part of the door assembly Including integrated self-supporting track, threaded rods and mechanical attachment hardware.
- F. **OPTION:** Vision Panel consisting of a frame and clear glass assembly with listings from Underwriters Laboratory up to 90 minutes.
- G. **OPTION:** A Key Switch shall be provided, located as directed by the Architect. (*Note: required with door equipped with Access Control option*)
- H. **OPTION:** Access Control: Shall inactivate Fire Exit Devices and sound an audible alarm in an attempt is made to manually operate the door assembly. A key switch shall be provided for authorized operation of the door assembly. A signal from the smoke detector or fire alarm will automatically override the access control feature. (*Note: at least one key-switch required.*)
- I. **OPTION:** An Individual LCD Door Status Display panel shall be provided adjacent to the door to indicate in the English language the status of the door, i.e. door position and trouble conditions. It shall have a port that allows easy access to a diagnostic tool for the purposes of field programming the door to customized settings. (*Note: Electrical requirements for the Individual LCD Door Status Display panel can be found in Section 1.02 E*)
- J. **OPTION:** Air Pressure Resistance. The door shall be capable of resisting an air pressure differential to 0.1 inches water column with the addition of anti-sway brackets placed interior to the door and lead post outriggers.

## 2.04 RELATED CONSTRUCTION

- A. Track Support Construction: Provide supports attached to structure and mounting surface for track including drilling/placement of anchorage points into pre or post tensioned decks, welding/punching/drilling steel members, and all drywall work; comply with door manufacturer's instructions and recommendations.
- B. Pocket Construction: Provide pocket for concealment of accordion door when open; comply with door manufacturer's instructions and recommendations.

## PART 3 – EXECUTION

### 3.01 EXAMINATION

- A. Verify that adjacent construction is suitable for installation of door.
- B. Verify that electrical utilities have been installed and are accessible.
- C. Verify that door opening is plumb and header is level and of correct dimensions.
- D. Notify Architect of any unacceptable conditions or varying dimensions.

### 3.02 INSTALLATION

- A. Install in accordance with manufacturer's instructions, shop drawings and NFPA 80.
- B. Install fire doors plumb and level.



# Won-Door FireGuard CS

## 3.03 ADJUSTING

- A. Adjust door installation to provide uniform clearances and smooth, quiet, non-binding operation.
- B. Test that all operations are functional and meet the requirements of local codes.

## 3.04 CLEANING

- A. Clean surfaces using manufacturer's recommended means and methods.

## 3.05 PROTECTION

- A. Protect installed work from damage.

## 3.06 STORAGE OF WASTE AND RECYCLING

- A. Store and recycle waste in accordance with Section 01 74 19 Construction Waste Management and Disposal.

Copyright © 2013 by Won-Door Corporation, all rights reserved.  
END OF SECTION





# Won-Door FireGuard CS

## HEAD DETAIL

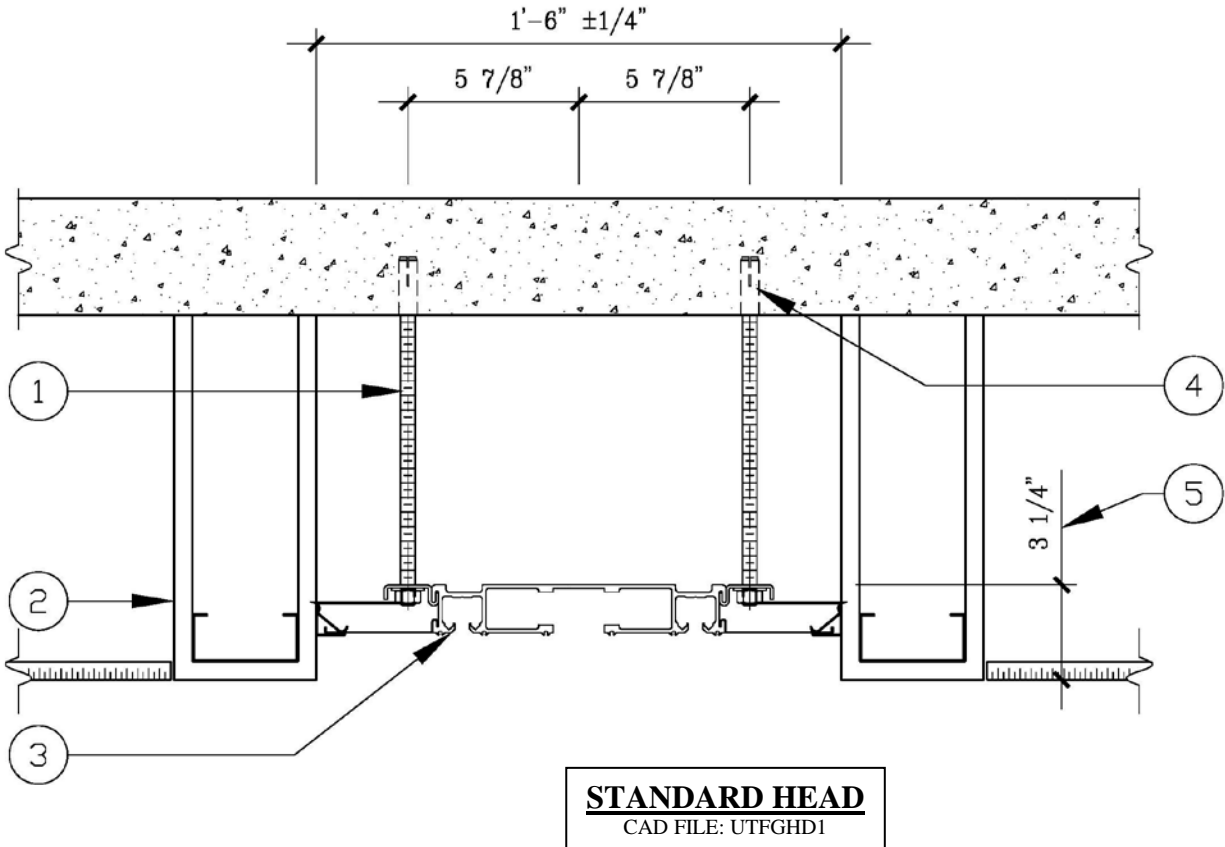

1. 1/2" dia. threaded rod with nuts and washers by Won-Door. (12" from each end and 24" O.C. across opening.)
2. Provide rated construction on each side corresponding to rating required for opening by others. (Note: 1 hour condition shown. To view additional rated conditions, visit our website @ [www.wondoer.com](http://www.wondoer.com))
3. Pre-finished white track and soffit assembly by Won-Door.
4. Structural support or anchorage by others. Structural support is not limited to concrete deck.
5. Minimum dimension required to meet U.L. compliance. The dimension may be increased to further recess the head condition if required.



Brackets [ ] indicate specifier's option



# Won-Door FireGuard CS

## PLAN VIEW - 12'-0" AND LESS OPENING WIDTH

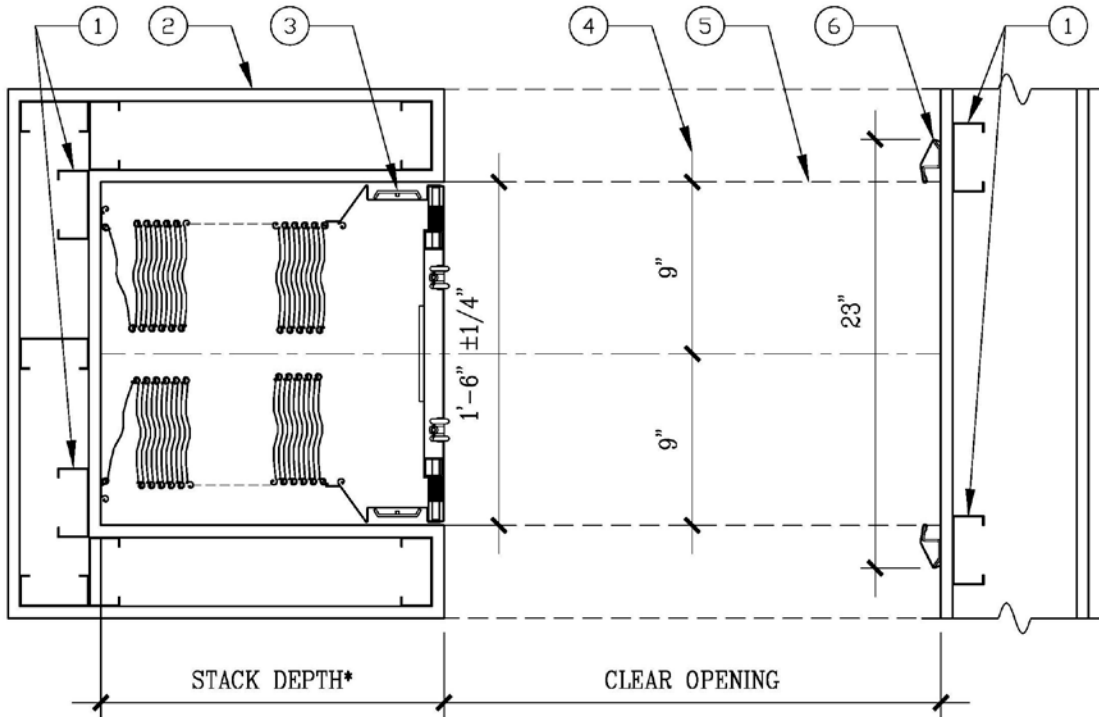

**SINGLE PARTING**  
CAD FILE: FGCCPLI

1. Continuous blocking by others.
2. Provide rated construction on each side corresponding to rating required for opening by others. (Note: 1 hour condition shown. To view additional rated conditions, visit our website @ [www.wondoors.com](http://www.wondoors.com))
3. Exit Devices.(meets all IBC Chapter 10 egress requirements)
4. Maintain 9" clearance on each side of the centerline of the door.
5. Fire rated bulkhead above, drop or flush with ceiling.
6. (2) 2 3/8" x 1 1/2" striker jambs by Won-Door. If recessed, provide 24" x 1 5/8" clearance. Finish wall to top of finished floor-no base or molding material allowed.
7. U.L. listed integrated cover door by Won-Door.

Specifier's  
note

\*To determine pocket depth, see the *Instructions* on page 83 and *Pocket Depth Calculation Chart* on page 84.



# Won-Door FireGuard CS

## PLAN VIEW - ABOVE 12'-0" OPENING WIDTH

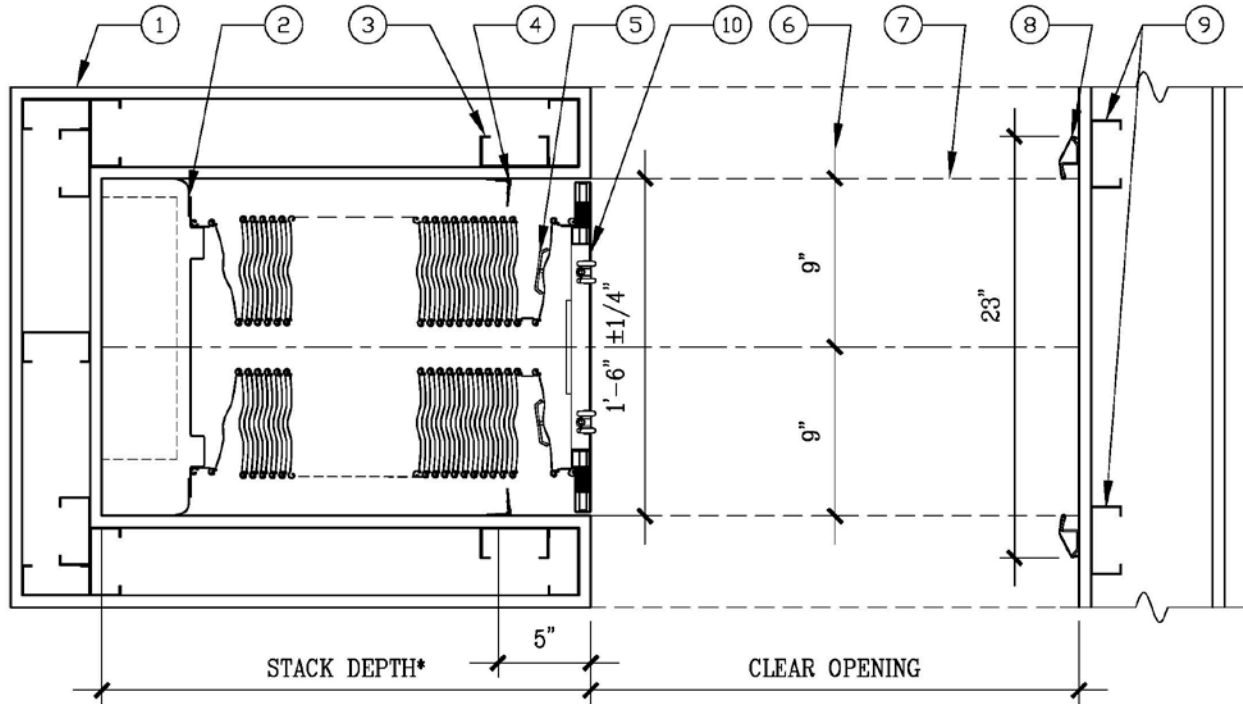

### **SINGLE PARTING**

CAD FILE: FGCSPL1

1. Provide rated construction on each side corresponding to rating required for opening by others. (Note: 1 hour condition shown. To view additional rated conditions, visit our website @ [www.wondoor.com](http://www.wondoor.com))
2. Sliding jamb assembly.
3. Continuous blocking by others.
4. Sliding jamb stops mounted 5" back from face of pocket.
5. Exit Devices. (meets all IBC Chapter 10 egress requirements)
6. Maintain 9" clearance on each side of the centerline of the door.
7. Fire rated bulkhead above, drop or flush with ceiling.
8. (2) 2 3/8" x 1 1/2" striker jambs by Won-Door. If recessed, provide 24" x 1 5/8" clearance. Finish wall to top of finished floor-no base or molding material allowed.
9. Continuous blocking by others.
10. U.L. listed integrated cover door by Won-Door.

Specifier's  
note

\*To determine pocket depth, see the *Instructions* on page 83 and *Pocket Depth Calculation Chart* on page 84.



# Won-Door FireGuard CS

## ELEVATION SIDE VIEW 12'-0" AND LESS OPENING WIDTH

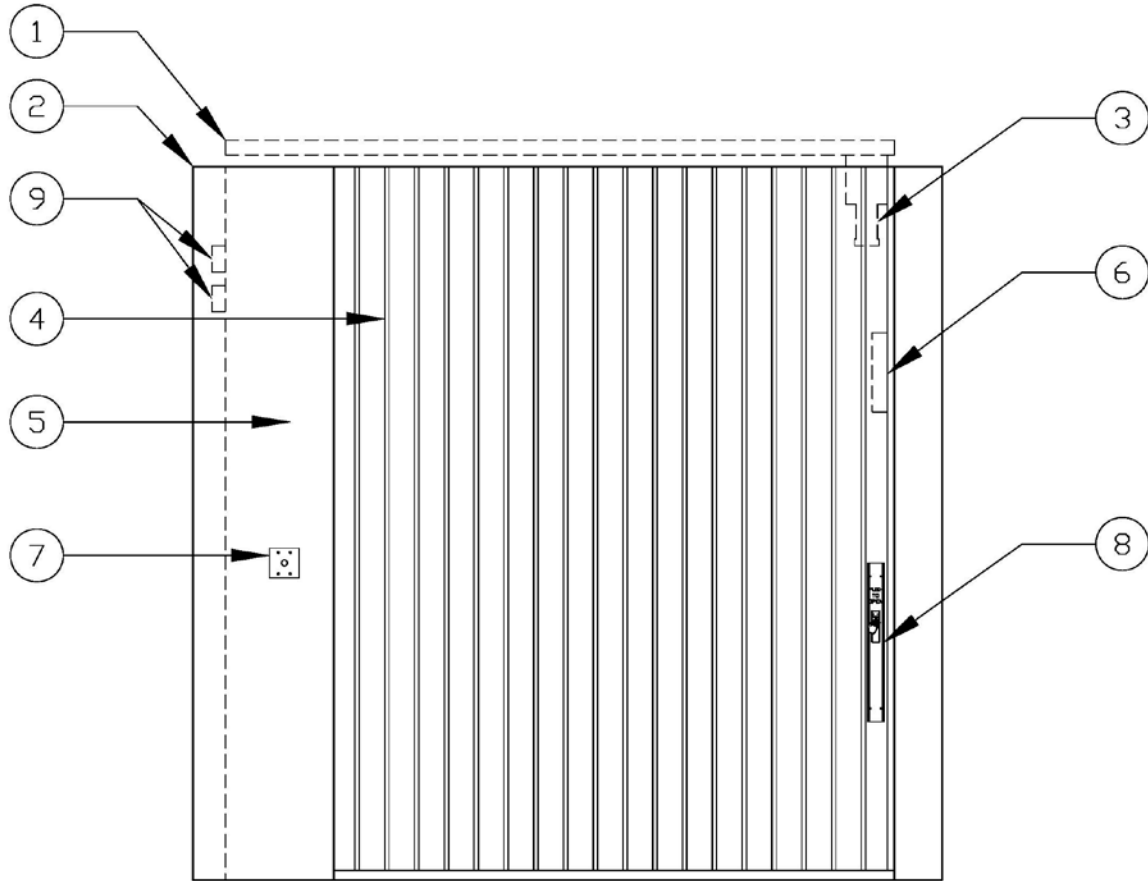

### **SLIM DRIVE MOTOR OPERATOR**

CAD FILE: FGCCELEV2

1. Top of door track. (Fabrication height.)
2. Ceiling line.
3. Motor operator assembly. (self-contained within lead post)
4. Folding fire door by Won-Door.
5. Storage pocket.
6. Electronic control box by Won-Door. (self-contained within lead post)
7. [Optional key switch by Won-Door. (See page 87.)
8. Fire exit devices mounted 36" A.F.F.
9. Two 4" x 4" junction boxes recess mounted 12" below top of track centered on back wall of pocket for required electrical connections.



Brackets [ ] indicate specifier's option

# Won-Door FireGuard CS

## ELEVATION SIDE VIEW ABOVE 12'-0" OPENING WIDTH

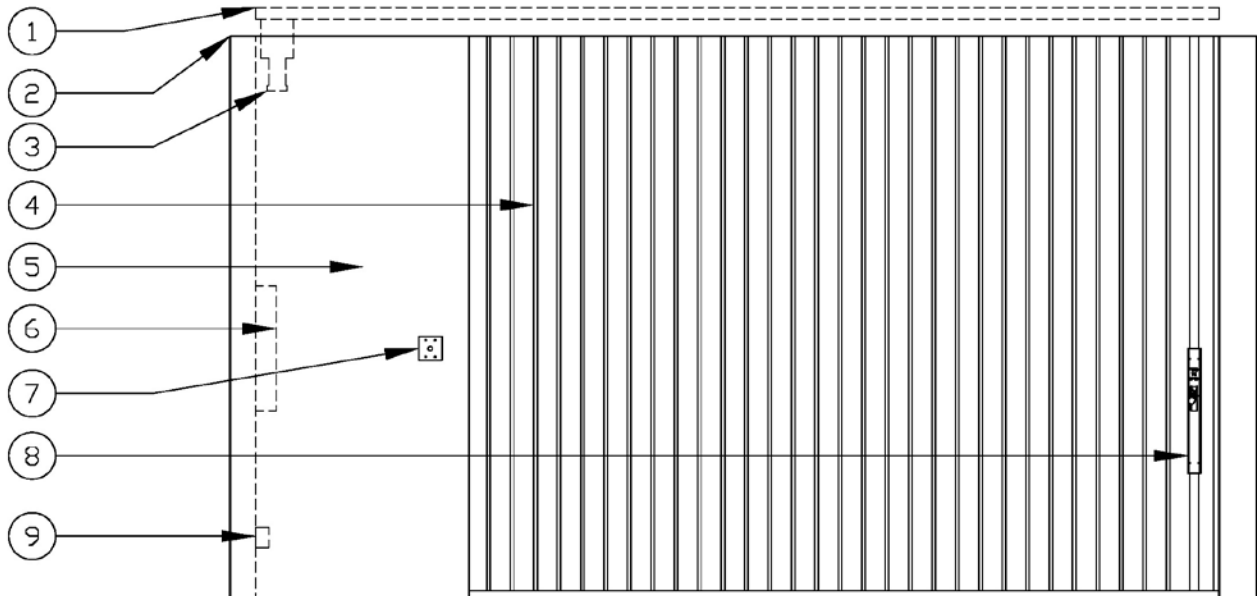

### **STANDARD POCKET MOUNTED MOTOR**

CAD FILE: FGELEV1

1. Top of door track. (Fabrication height.)
2. Ceiling line.
3. Motor operator assembly.
4. Folding fire door by Won-Door.
5. Storage pocket.
6. Electronic control box by Won-Door.
7. [Optional key switch by Won-Door. (See page 87.)]
8. Fire exit devices mounted 36" A.F.F.
9. Two 4" x 4" junction boxes surface mounted side by side on back wall of pocket 12" A.F.F. for required electrical connections.



Brackets [ ] indicate specifier's option



# Won-Door FireGuard CS

## ELEVATION FRONT VIEW

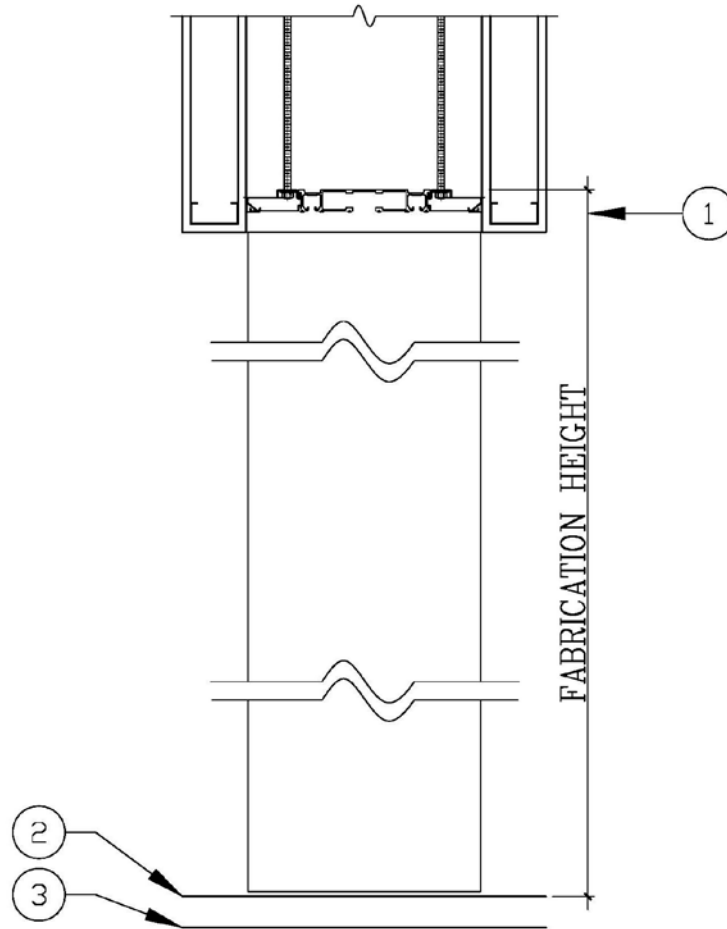

### **STRAIGHT DOOR**

CAD FILE: FGCCELEV3

1. Fabrication height/field dimension height taken from top of track to top of finished floor.
2. Finished floor. (Carpet, tile, etc.)
3. Sub floor. (Concrete, etc.)

#### Door Profile Widths:

- Stacked Width: 14"
- Extended Width: 9"

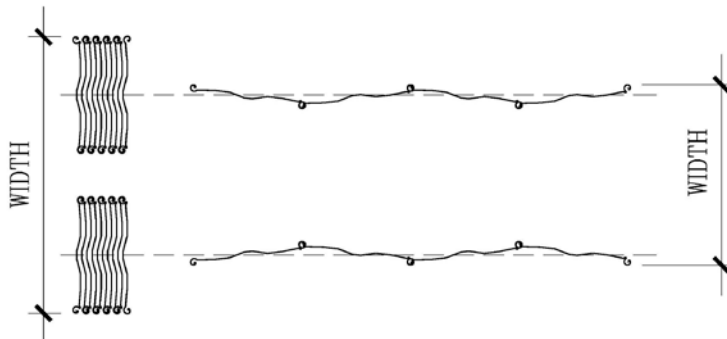

# Won-Door FireGuard CS

## POCKET DEPTH CHART INSTRUCTIONS

The term CLEAR OPENING WIDTH on the *Pocket Depth Calculation Chart* refers to the distance from the front of the storage pocket to face of the striker.

To determine the pocket depth requirement of a door:

1. Determine the door's CLEAR OPENING WIDTH
2. Find the appropriate range for that width (*From-To* columns)
3. Find the minimum stack depth for that range.
4. Consult the *Options Affecting Pocket Depth* section below the chart to determine how optional equipment affects stack requirements.

**Example below:** Pocket depth for FireGuard CS single parting door w/ 10'-5" clear opening (in the range from 10'-1" to 10'-10"). Minimum pocket depth = 2'-2".

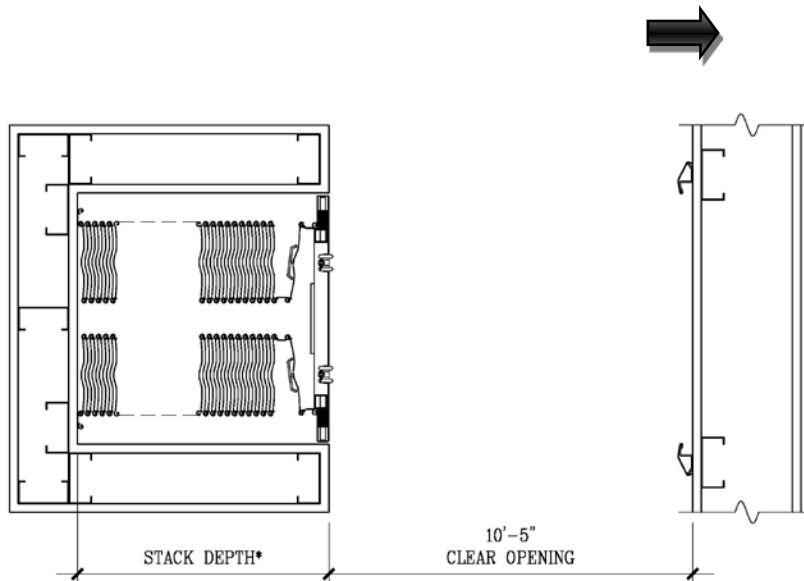

### List of Options Affecting Pocket Depth

- Security: Add 1" to the stack depth.
- Vision panels: Add 1" to the stack depth.
- Fire Exit Devices: Add 2" to the stack depth for each additional device.



# Won-Door FireGuard CS

## POCKET DEPTH CALCULATION CHART

FireGuard CS

Clear Opening Width		Pocket Depth	
		Height less than or equal to: 10'-3 1/4"	Height less than or equal to: 12'-3 1/4"
From:	To:		
0'-0"	9'-6"	1'-9"	2'-3"
9'-6"	10'-5"	1'-10"	2'-3"
10'-5"	11'-3"	1'-11"	2'-3"
11'-3"	12'-0"	2'-1"	2'-3"
12'-0"	13'-0"	2'-2"	2'-5"
13'-0"	13'-11"	2'-3"	2'-5"
13'-11"	14'-9"	2'-4"	2'-5"
14'-9"	15'-8"	2'-5"	2'-5"
15'-8"	16'-6"	2'-6"	2'-6"
16'-6"	17'-5"	2'-8"	2'-8"
17'-5"	18'-3"	2'-9"	2'-9"
18'-3"	19'-2"	2'-10"	2'-10"
19'-2"	20'-0"	2'-11"	2'-11"
20'-0"	20'-11"	3'-0"	3'-0"
20'-11"	21'-9"	3'-1"	3'-1"
21'-9"	22'-8"	3'-2"	3'-2"
22'-8"	23'-6"	3'-3"	3'-3"
23'-6"	24'-5"	3'-4"	3'-4"
24'-5"	25'-3"	3'-5"	3'-5"
25'-3"	26'-2"	3'-7"	3'-7"
26'-2"	27'-0"	3'-8"	3'-8"
27'-0"	27'-11"	3'-9"	3'-9"
27'-11"	28'-9"	3'-10"	3'-10"
28'-9"	29'-8"	3'-11"	3'-11"
29'-8"	30'-0"	4'-0"	4'-0"

### Limitations and Considerations:

- Pocket Cover Door:** The pocket cover is integrated into the lead post.
- Size:** Maximum height is 12'-3 1/4". Maximum width is 30'.
- Fire Rating:** Fire ratings up to 3 hours are available.
- Security:** Level 1 or level 2 may be specified. For level 2 security, add 4" to the stack.
- Vision Panels:** If a vision panel is required, add 1" to the stack depth.
- Exit Devices:** First set of exit devices is included. Add 2" to stack depth for each additional device.
- Air Pressure:** Maximum of 0.1" W.C. is allowed. (additional equipment is required)
- Smoke Rating:** S or SE ratings are available.
- Bi-Part:** Not available.
- Curves:** Not available.
- Temperature Rise:** Not available.
- Moveable Fire Wall:** Not available.





# Won-Door FireGuard CS

## SLIM DRIVE MOTOR OPERATOR ELECTRICAL DIAGRAM

For CS doors 12'-0" wide or less

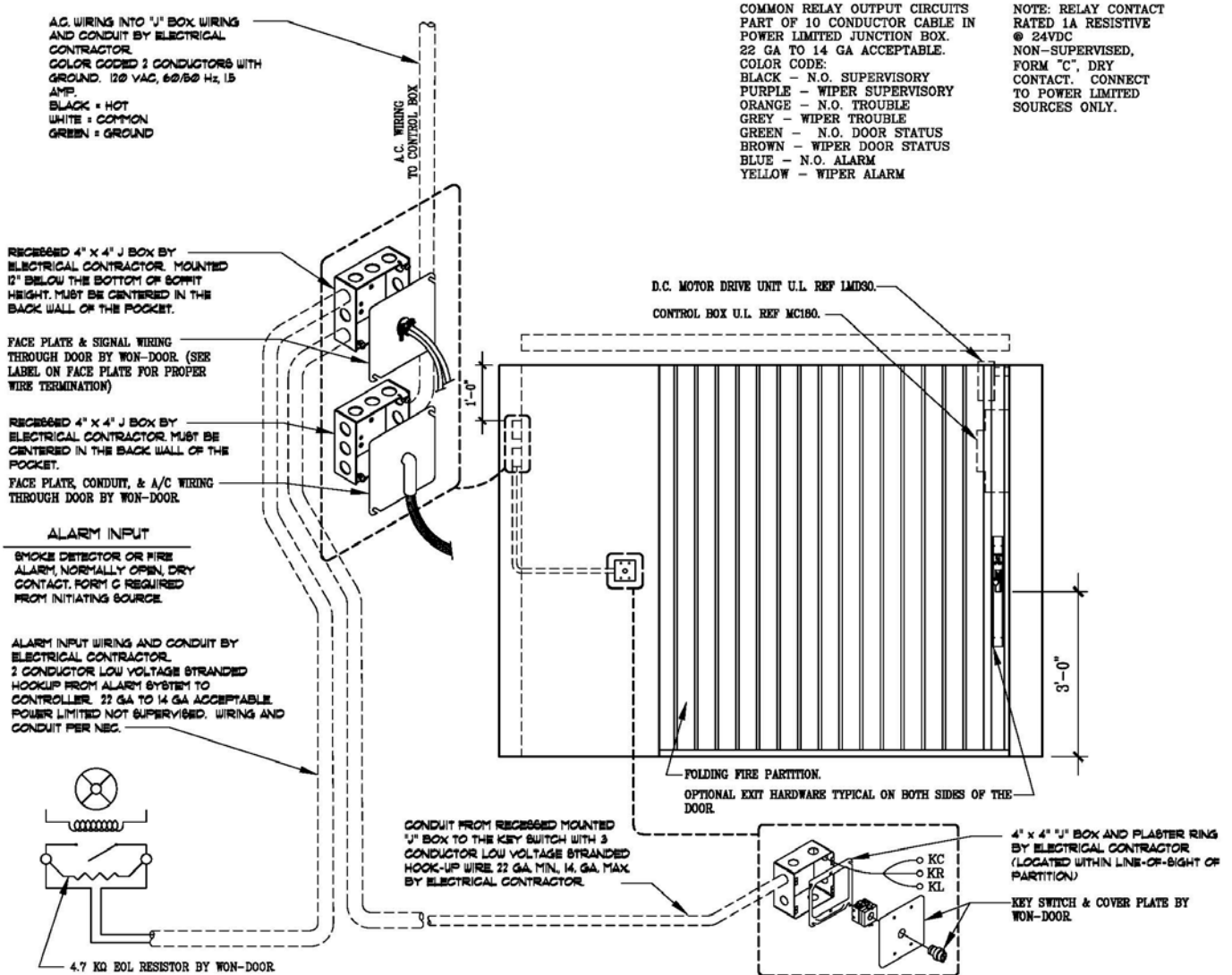

Note: Cable lengths referred to in this detail are actual cable lengths, not straight line distances. If cable length exceeds 25 wire feet, consult the factory.  
 Key switch is required with access control.



# Won-Door FireGuard CS

## POCKET MOUNTED MOTOR OPERATOR ELECTRICAL DIAGRAM

For CS doors greater than 12'-0" wide.

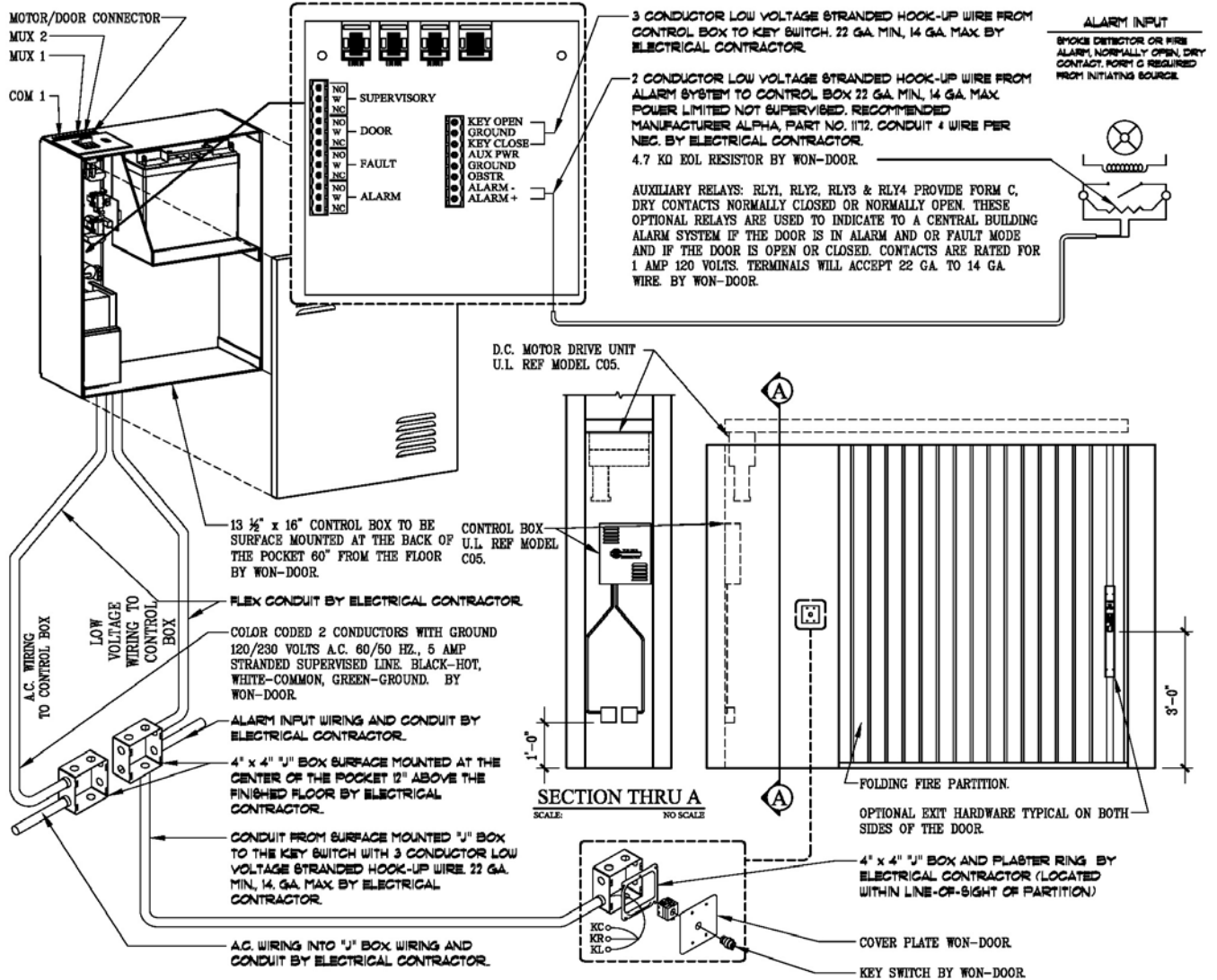

**Specifier's note**

Note: Cable lengths referred to in this detail are actual cable lengths, not straight line distances. If cable length exceeds 25 wire feet, consult the factory.  
Key switch is required with access control.



# Won-Door FireGuard CS

## OPTIONAL KEY SWITCH

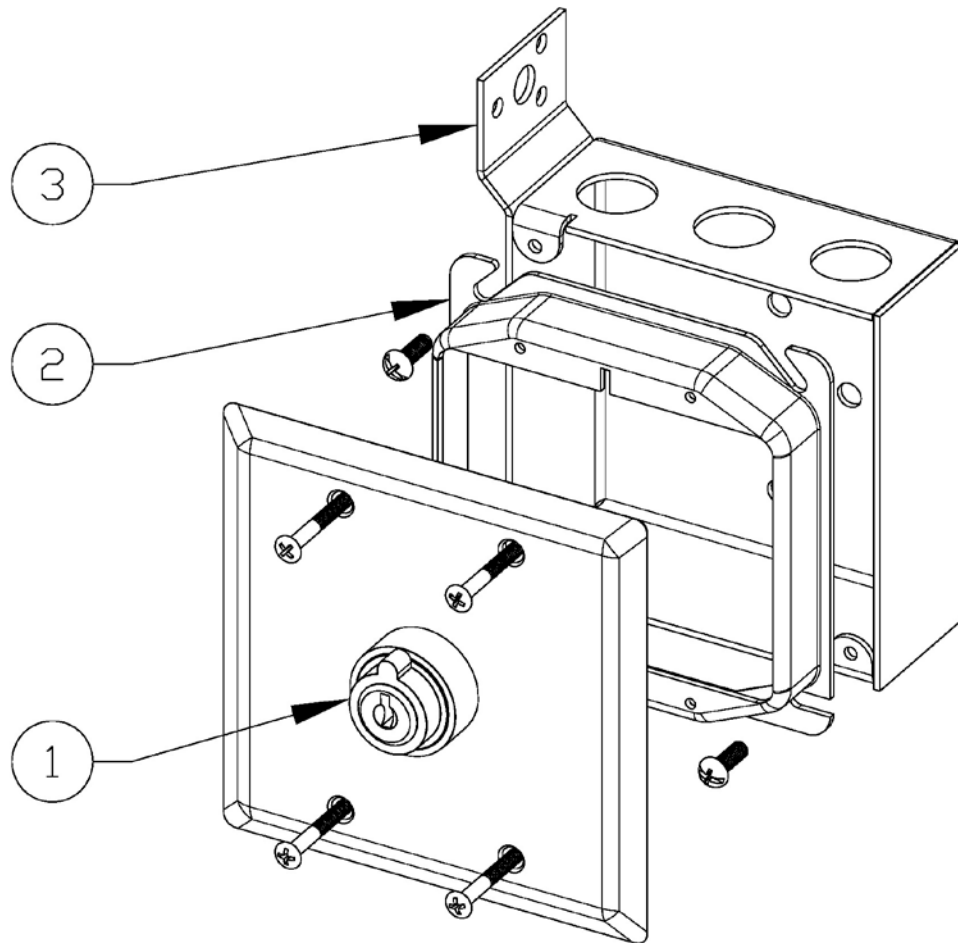

1. Key switch module.
2. Plaster ring by others.
3. 4" x 4" x 2 1/2" electrical box by others.

Key switches are *optional* except for the following application:

1. Large door motor operator assemblies

For safety reasons, a key switch must be installed within line-of-sight of the operation of the Won-Door FireGuard door.

Specifier's  
note



# Won-Door FireGuard CS

## CCOM ROCKER SWITCH

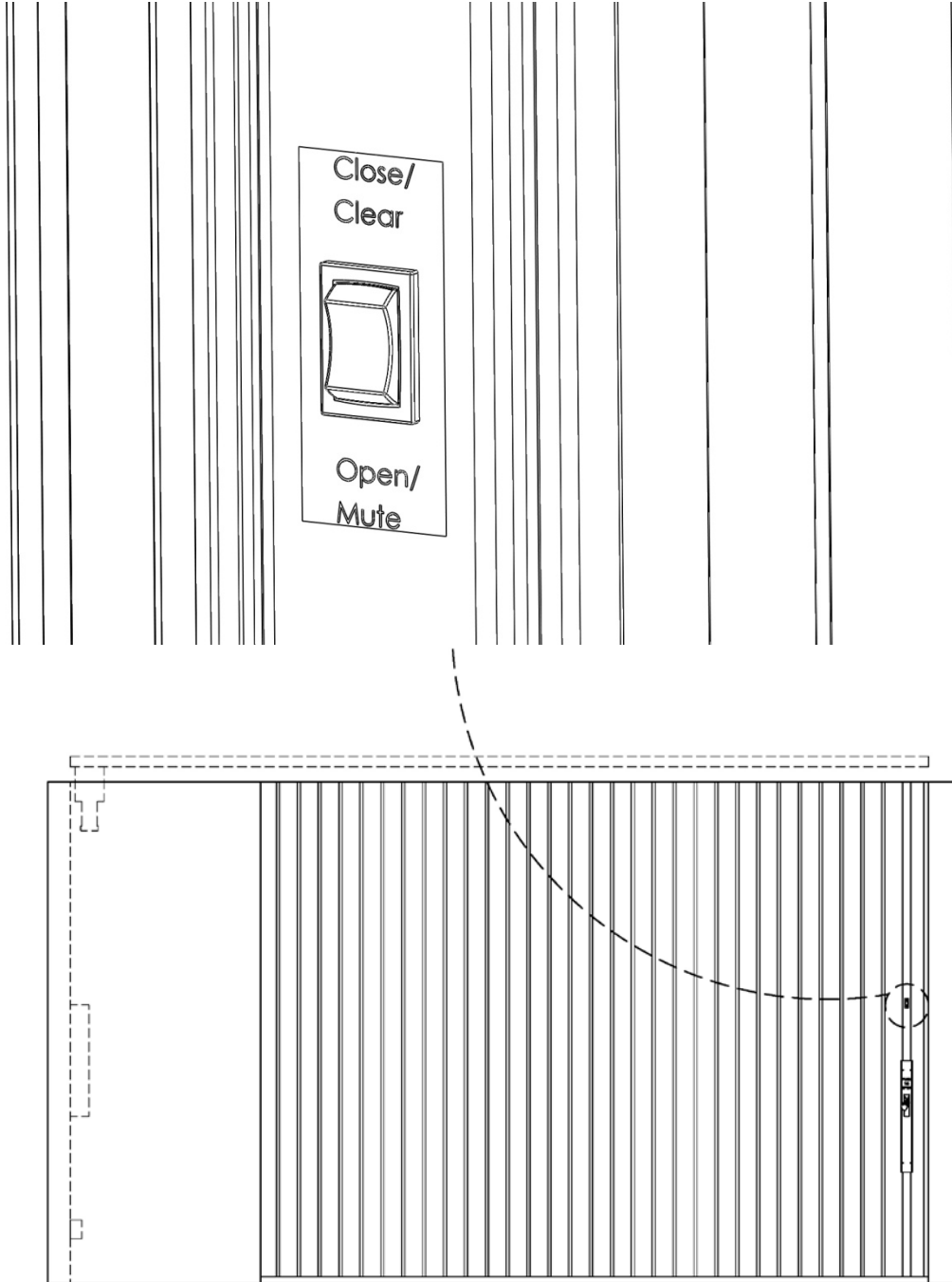

CCOM rocker switch is included when a key switch is not specified. The switch is used to open and close the door and to reset and silence door faults.



# Won-Door FireGuard CS

## OPTIONAL VISION PANEL

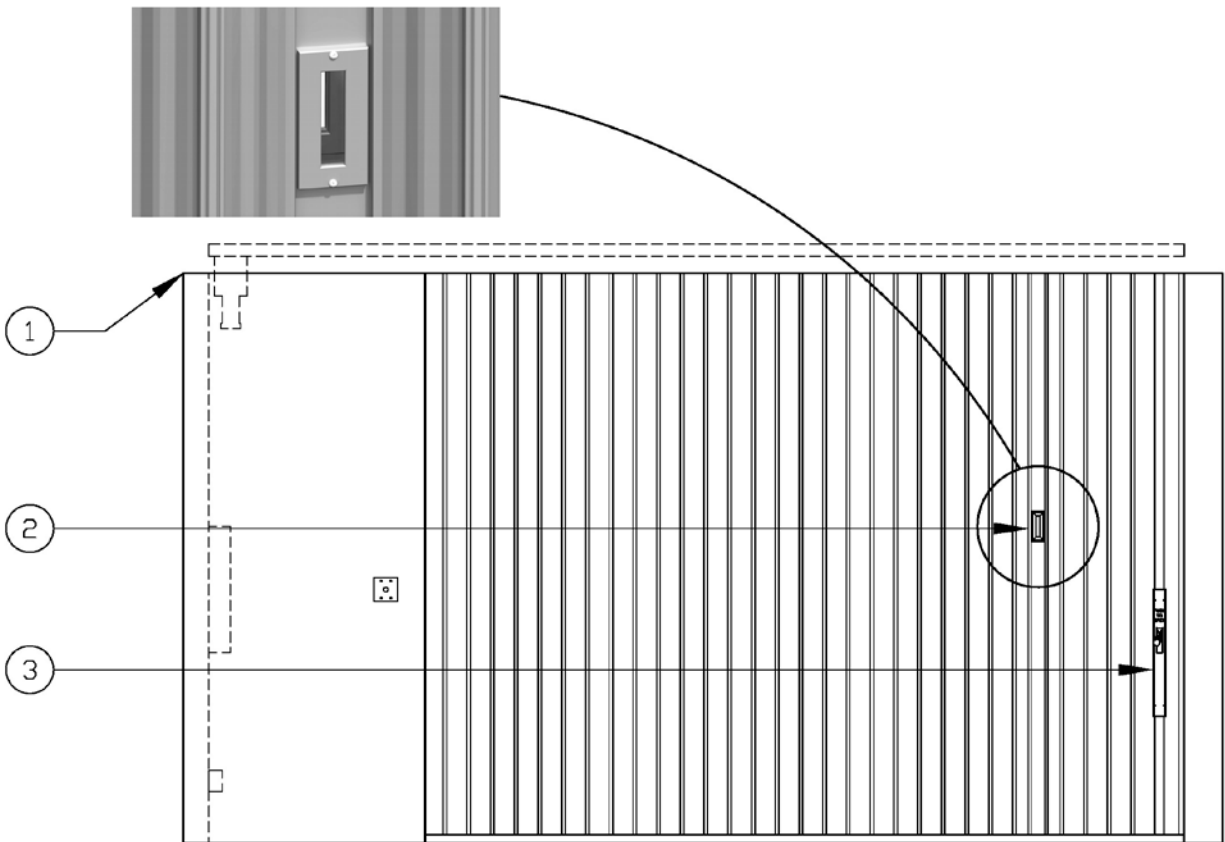

1. Ceiling line.
2. 1 1/2-hour U.L. listed Vision Panel. Required only for smoke barrier applications in Group I occupancies. Maximum size is 5 3/4" x 2 5/8".
3. Exit devices mounted 36" A.F.F.



# Won-Door FireGuard CS

## OPTIONAL MULTIPLE EXIT DEVICE DETAIL

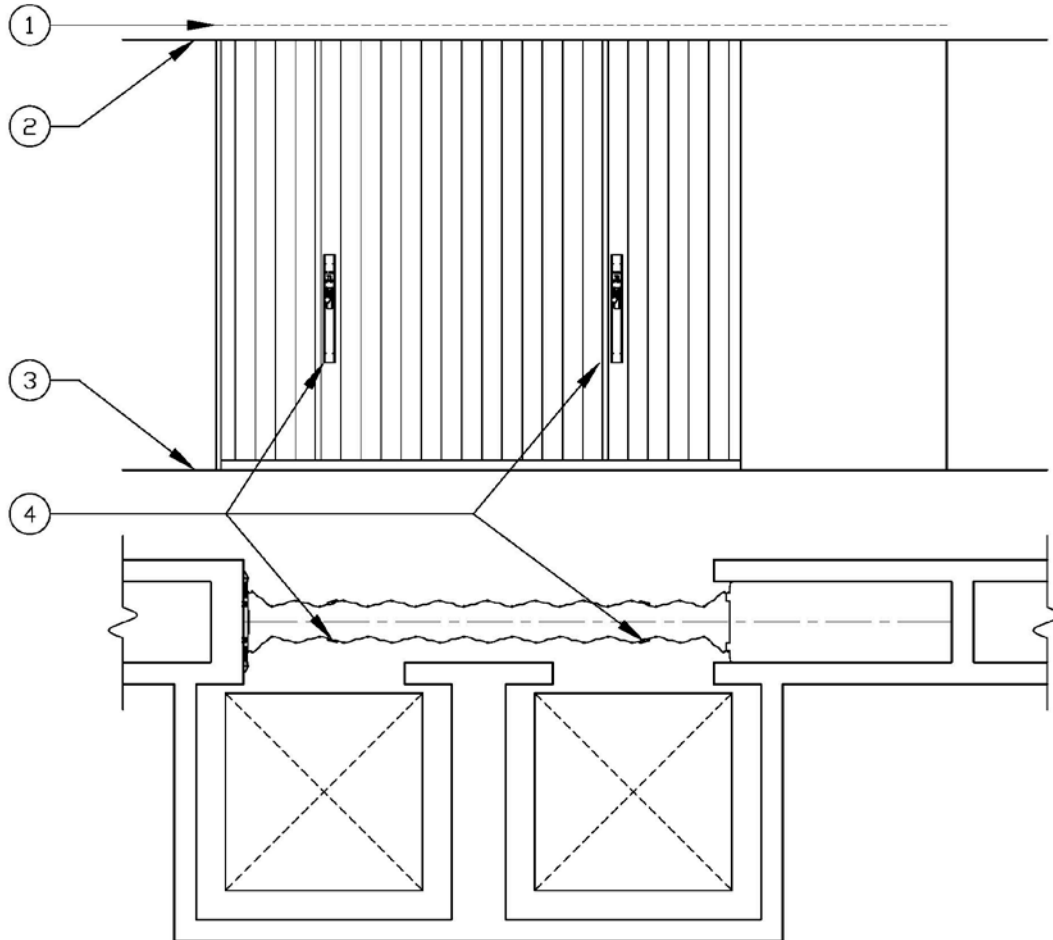

1. Top of track.
2. Ceiling line.
3. Finished floor.
4. Exit devices. (In sets, one on *each side* of the door, **or** one side only.)

Specifier's  
note

1. Up to three (3) sets of exit devices per leaf may be specified at any horizontal locations on the door (example above shows two sets in front of a bank of elevators). Upon activation of the exit devices, the FireGuard door will open to a field-programmable distance.
2. Add 1" to stack or pocket depth for each set of exit devices.

# Won-Door FireGuard MFW

## GUIDELINES FOR FIREGUARD MOVEABLE FIRE WALL

**Won-Door FireGuard MFW** (Moveable Fire Wall) doors have been tested in accordance with the ASTM E-119 and UL 263 standard for moveable fire walls. FireGuard MFW is offered as an opening protective in a fire barrier following the provision of Section 707.6.3 (2009 IBC) that states “Openings shall not be limited to 156 square feet or an aggregate width of 25 percent of the length of the wall where the opening protective has been tested in accordance with ASTM E 119 or UL 263 and has a minimum *fire resistance rating* not less than the *fire resistance rating* of the wall.” This product is offered as a design alternative to fire rated glass and other ASTM E 119 rated assemblies.

Moveable fire walls are limited to a maximum length of 20’-0” and a maximum height of 9’-0”. They are not available in bi-parting or curved configurations. Moveable fire walls must have at least a 20” wide pocket,

This section includes a Specification and a Pocket Depth Calculation chart that apply specifically to Won-Door FireGuard MFW.



# Won-Door FireGuard MFW

This page intentionally left blank.





# Won-Door FireGuard MFW

SECTION: 08 35 13.23 – ACCORDION FOLDING FIRE DOORS

## PART 1 – GENERAL

### 1.01 SUMMARY OF WORK

- A. Division 0 and 1, as indexed, apply to this section.
- B. Furnish and install all horizontal sliding, accordion folding fire doors shown on the drawings and specified herein.

### 1.02 RELATED SECTIONS

- A. All headers, support structures, fire protection of support structures, surrounding insulation, jambs, storage pockets, pocket doors, access doors, blocking and trim shall be furnished and installed by other sections. Plywood headers may be included under Section 2.03 E. The plywood header option does not include support structures, fire protection of support structures, surrounding insulation, jambs, storage pockets, pocket doors, access doors, blocking, drywall work or trim.
- B. All electrical wire, wiring, conduit and electrical boxes shall be furnished and installed by electrical section including connections to smoke detectors and building fire alarm panels.
- C. Drilling/placement of anchorage points into pre or post tensioned decks, welding/punching/drilling steel members and all drywall work.
- D. **OPTION:** All track, soffit, chain guide and wall mounted striker posts shall be painted by Section 09900. Color shall be selected by the architect.
- E. **OPTION:** *If Section 2.03 G, Individual LCD Door Status Display, is selected as an option, the following paragraph should be included:* Wiring for Individual LCD Door Status Display at fire door-One (1) USOC RJ14-6POS 4 wire jack shall be supplied at the back of the storage pocket and shall be tied to the 4 square junction box adjacent to the door with CAT 5 twisted 2 pair cable. The junction box, RJ14 jack and wire shall be furnished and installed by the electrical section. Termination to the LCD panel shall be by punch down block and shall be by the electrical section as per the manufacturer's instructions.

### 1.03 QUALITY ASSURANCE

- A. Installation shall be performed by factory trained and certified installers with a minimum of three years experience installing electrically operated accordion folding fire doors.
- B. Fire doors shall be listed by Underwriters Laboratories for ratings as indicated, when tested in accordance with the requirements of UL 263 and ASTM E-119.
- C. Automatic closing system shall be listed by Underwriters Laboratories in accordance with the requirements of UL 864 and be listed for use with assembly in compliance with NFPA 80, Chapter 9. Motor operator shall be rated for continuous use with unlimited cycle duty.

### 1.04 SUBMITTALS

- A. Refer to Section 01 30 00 – Administrative requirements for shop drawings and submittals.
- B. Product Data: Provide manufacturer's technical literature; include UL listing data.
- C. Shop Drawings: Indicate construction and installation details and dimensions, including layout, electrical requirements, required stacking depth, height of header above finished floor, and requirements for anchorage and support of each door.



# Won-Door FireGuard MFW

- D. Operation and Maintenance Data: Operating manual, troubleshooting and repair methods, and wiring diagrams shall be provided as part of project close out procedure.

## 1.05 DELIVERY, STORAGE, AND HANDLING

- A. Deliver to the job site in manufacturer's original, unopened package.

## 1.06 COORDINATION BY GENERAL CONTRACTOR

- A. Coordinate with the following:
  - 1. Fire Alarm System.
  - 2. Electrical.
  - 3. Panel pocket doors and wood veneer paneling (if applicable).
  - 4. Floor and ceiling finish.
- B. Assure accurate installation of header, jamb, and trim. Provide "As-Built" dimensions for opening and storage pocket. Supervise unloading and handling of materials.
- C. Permanent power shall be in-place and ready for final connection when fire doors are erected. Assure access to and proper clearance for motor operators.
- D. After testing the fire alarm system, automatic-closing fire doors shall be re-set to the original position.
- E. Store boxes flat (not more than three high) in a dry area and protect from elements that may damage materials. Replace damaged materials at no cost to the owner.

## 1.07 WARRANTY

- A. Materials and installation shall be warranted against defects in workmanship for a period of one (1) year from the date of substantial completion.

## PART 2 – PRODUCTS

### 2.01 MANUFACTURER AND MODEL

- A. Horizontal sliding opening protective shall be Won-Door FireGuard Moveable Fire Wall model MFW\_\_\_\_ (*select one: 1 or 2 – number designates hours of fire rating*) as manufactured by Won-Door Corporation, Salt Lake City, UT.
- B. Products of other manufacturers demonstrating complete compliance with each of the fire rating and performance criteria of the product specified will be considered for approval. Written requests for substitutions will be considered by the architect up to ten days prior to the bid date.
- C. **OPTION:** No substitutions allowed.

### 2.02 ACCORDION FIRE DOORS - GENERAL

- A. Provide power operated self-closing fire doors of configurations indicated on the drawings.
  - 1. Fire rating as required.
- B. Fire Rating: Fire Doors shall be listed by Underwriters Laboratory as special purpose fire doors having a (*select one: 1 or 2*) hour fire-resistive rating in accordance with the requirements of UL 263 and ASTM E-119.
- C. Closing and Opening Operation: Automatic Closing System including motor operator and releasing devices shall be a Microprocessor-based system rated to UL864 (Releasing Device



# Won-Door FireGuard MFW

Control Unit) and shall commence closing upon activation by fire alarm system and/or by low battery charge.

1. Obstruction Detection: Contact with an obstruction shall cause the door to stop, reverse enough to remove pressure on the leading edge, pause, and then re-close when in an alarm condition.
2. While the door is opening under motor power, constant pressure to the leading edge in the direction of opening shall cause the door to continue to open until the leading edge is released. This is termed motor-assisted opening.
3. Constant pressure to the leading edge while not under motor power shall prevent motor operation and allow the door to be opened manually.

## 2.03 COMPONENTS

- A. Door Construction: Two parallel, accordion-type walls of panels independently suspended with no floor tracks, pantographs, or interconnections except at the lead-post.
  1. Panels: 24 gauge steel; V-grooved; modular design; capable of in-place repair.
  2. Perimeter Seals: shall consist of continuous extruded vinyl sweeps attached to the top and bottom of the fire door to form a smoke and draft seal.
  3. Hanging weight shall be 6.5 pounds per square foot when extended across the opening.
  4. Finish: All steel parts factory applied enamel.
  5. Color: Manufacturer's standard platinum.
- B. Suspension System: Two tracks, on 8 inch centers, attached to overhead structural support.
  1. Tracks: 14 gauge cold rolled steel or .125 aluminum.
  2. Panel hangers: Each panel suspended from a steel hanger pin and a ball bearing roller.
  3. Lead post hangers: 8 wheel ball bearing trolley.
- C. Power Supply: 12-volt/24-volt maintenance-free DC battery, automatically maintained at capacity by continuous charger, 120 V AC.
- D. Automatic Closing System shall be listed to UL864 including capability to send and receive signals from the Fire Control Panel and shall consist of the following:
  1. Microprocessor based Electronic Control box with these features:
    - a. Ability to monitor dual power sources continually for peak performance including:
      - 1) Detect a missing battery, bad battery, or low battery condition.
      - 2) Detect if the charging circuit is bad.
      - 3) Detect fuse failures.
      - 4) Detect high or low AC conditions.
    - b. Ability to monitor the health of the drive train.
    - c. Ability to monitor inputs including: sticky door block, exit devices, patron devices, and key switches.



# Won-Door FireGuard MFW

- d. Ability to run a “watch dog” monitoring circuit which will force a software restart in the event the software hangs, including the ability to track the number of resets that occur for diagnostic purposes.
  - e. Ability to withstand voltages up to 120 volts AC on the fire alarm input circuit without damage including the ability to indicate that the alarm circuit has not been wired as a dry contact, “no voltage” circuit when errant voltages are applied to the circuit.
  - f. Ability to communicate with other microprocessors in the assembly via an internal buss system.
  - g. Ability to indicate trouble or supervised information both locally and at a remote location.
2. Motor Operator Assembly including: A DC gear-motor, drive sprocket, clutch, and position sensors. The motor shall drive the fire door by means of a chain attached to a stabilizer bar trolley. The motor shall be rated for continuous use with unlimited cycle duty.
  3. If a key switch (**NOTE:** Section 2.03 F) is NOT used, a door control momentary rocker switch shall be mounted on one side of the door near the lead post and shall have the following functions:
    - a. Pressing the upper portion of the switch shall close the door and/or clear fault conditions.
    - b. Pressing the lower portion of the switch shall open the door and/or temporarily mute the local horn.
    - c. For doors using wall mounted key switches, Section 2.03 F, a color coordinated cover plate shall be provided to fill the hole left when the rocker switch is removed.
  4. Leading Edge Obstruction Detector: Shall be pressure sensitive such that contact with an obstruction shall cause the door to stop, pause for 3 seconds, and then re-close when in an alarm mode. The obstruction detection system shall be fully functional at all times.
- E. **OPTION:** Plywood headers shall be provided. Installation is contingent on the structural support being less than five (5) feet above the plywood header assembly. Materials included are the plywood, threaded rods, and mechanical attachment hardware only. Drilling/placement of anchorage points into pre- or post-tensioned decks is by others. Welding/punching/drilling of steel members is by others. All drywall work is by others. Field dimensions are included.
- F. **OPTION:** A Key switch module shall be provided, located as directed by the Architect. (*Note: required with Access Control devices.*)
- G. **OPTION:** An Individual LCD Door Status Display panel shall be provided adjacent to the door to indicate in the English language the status of the door, i.e. door position and trouble conditions. It shall have a port that allows easy access to a diagnostic tool for the purposes of field programming the door to customized settings. (*Note: Electrical requirements for the Individual LCD Door Status Display panel can be found in Section 1.02 E*)
- H. **OPTION:** Air Pressure Resistance. The door shall be capable of resisting an air pressure differential between 0.05 - 0.15 inches water column and maintain normal operation. For air pressure differentials of 0.05 to 0.1, anti-sway brackets shall be placed interior to the door



# Won-Door FireGuard MFW

approximately every five (5) feet or less and lead post outriggers shall be provided; for air pressure differentials of 0.1 to 0.15, a self-leveling lead post assembly shall provide motorized tracking of the leading edge of the door to assure proper closure. (*NOTE: edit above selections depending on level of pressure differential expected*)

- I. **OPTION:** An infrared light beam shall be provided on non-curved doors to monitor the opening path. In the event that an object is placed in the path of the door for more than 4 minutes, the beam shall cause the door to sound an alarm indicating a path obstruction.
- J. **OPTION:** Level 1 Access Control: A rigid jamb stop and key switch shall be provided for authorized operation of the door assembly. A signal from the smoke detector or fire alarm will automatically override the access control feature. (*Note: at least one key-switch required.*)
- K. **OPTION:** Level 2 Access Control. The door(s) shall be programmable such that when in the access control mode, the exit devices shall not respond when pressed until activated/overridden by a signal from the smoke detector or fire alarm. Door(s) shall also include a steel sliding jamb, rigid jamb stops, and 10 gauge steel vertical reinforcement to the lead post. An electromagnetic locking brake shall be added to the motor operator assembly to provide 400-500 pounds of resistance to manual opening. Key switch/alarm module shall be provided to open/close/reset the doors. (*Note: Level 1 and Level 2 Access Control options are independent systems and may not be specified in conjunction with each other*)

## 2.04 RELATED CONSTRUCTION

- A. Track Support Construction: Provide supports attached to structure and mounting surface for tracks; comply with door manufacturer's instructions and recommendations, Headers, if furnished & installed by the general contractor or other sections, shall be parallel with the finished floor within +/- 1/8" tolerance over the entire length of the opening.
- B. Pocket Construction: Provide pocket for concealment of accordion folding fire door when open; comply with door manufacturer's instructions and recommendations to ensure pocket and soffit are built to the dimensions specified, plumb and level.
- C. Pocket Door: Maintain full pocket clear width when pocket door is open.
- D. Striker Recess: mount 16 gauge steel striker in wall recess deep enough to prevent striker from protruding beyond face of wall; construct recess to maintain fire rating of wall.

## PART 3 – EXECUTION

### 3.01 EXAMINATION

- A. Verify that adjacent construction is suitable for installation of door.
- B. Verify that electrical utilities have been installed and are accessible.
- C. Verify that door opening is plumb and header is level and of correct dimensions.
- D. Notify Architect of any unacceptable conditions or varying dimensions.

### 3.02 INSTALLATION

- A. Install fire doors in accordance with manufacturer's instructions, shop drawings, and NFPA 80.
- B. Install fire doors plumb and level.



# Won-Door FireGuard MFW

- C. Installation shall be performed by factory trained and certified installers with a minimum of three years experience installing electrically operated accordion folding fire doors.

## 3.03 ADJUSTING

- A. Adjust door installation to provide uniform clearances and smooth, quiet, non-binding operation.
- B. Test that all operations are functional and meet the requirements of local codes.

## 3.04 CLEANING

- A. Clean surfaces using manufacturer's recommended means and methods.

## 3.05 PROTECTION

- A. Protect installed work from damage.

## 3.06 STORAGE OF WASTE AND RECYCLING

- A. Store and recycle waste in accordance with Section 01 74 19 Construction Waste Management and Disposal.

Copyright © 2013 by Won-Door Corporation, all rights reserved.  
END OF SECTION





# Won-Door FireGuard MFW

## MFW – PLAN VIEW

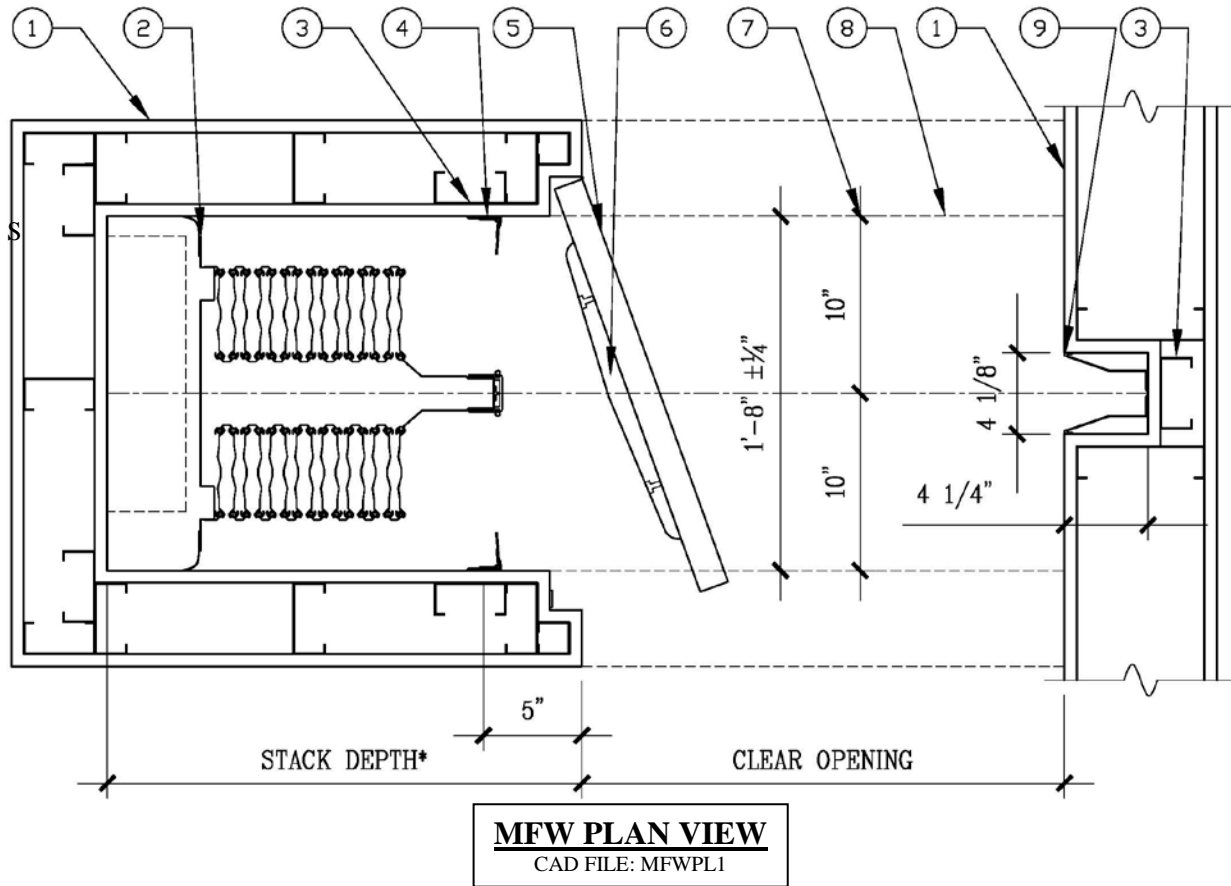

1. Provide rated construction on each side corresponding to rating required for opening by others. (Note: 1 hour condition shown. To view additional rated conditions, visit our website @ [www.wondoor.com](http://www.wondoor.com))
2. Sliding jamb assembly.
3. Blocking by others.
4. Sliding jamb stops mounted 5" back from face of pocket.
5. Non-rated pocket cover door by others. (See pages 105 106)
6. Door bumper by others. Bumper required when spring loaded hinge is not used. (See page 106)
7. Maintain 10" clearance on each side of the centerline of the door.
8. Fire rated bulkhead above, drop or flush with ceiling.
9. Recessed into rated construction striker by Won-Door to be caulked by others.

Specifier's  
note

Brackets [ ] indicate specifier's option

\*To determine pocket depth, see the *Instructions* on page 103 and *Pocket Depth Calculation Chart* on page 104.



# Won-Door FireGuard MFW

## MFW – ELEVATION SIDE VIEW

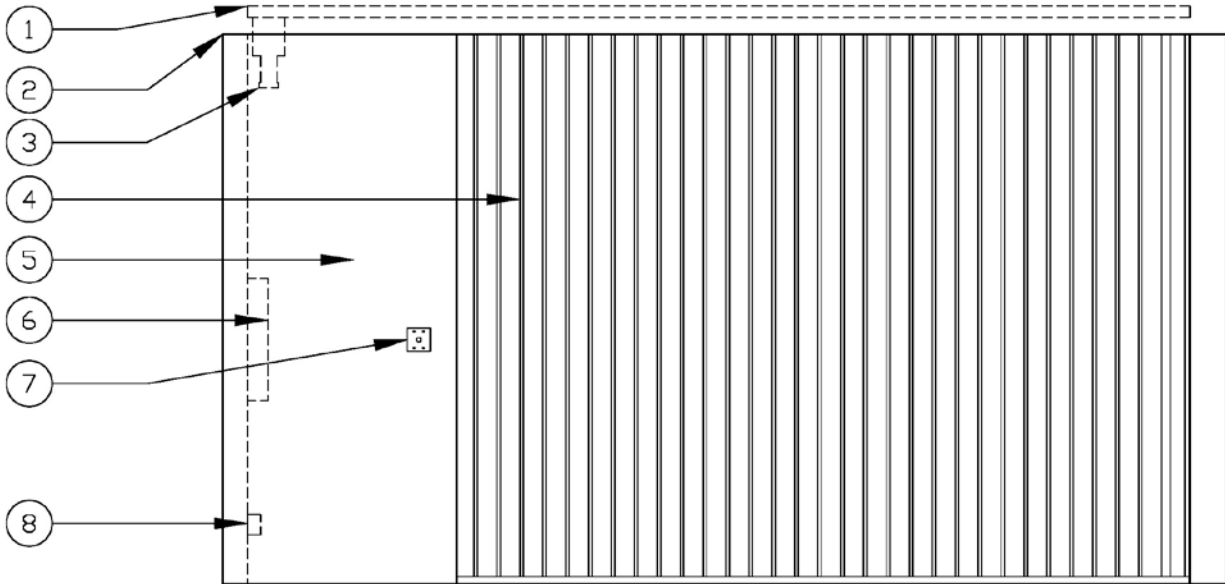

### **STANDARD POCKET MOUNTED MOTOR**

CAD FILE: MFWELEV1

1. Top of door track. (Fabrication height.)
2. Ceiling line.
3. Motor operator assembly.
4. Folding moveable fire wall by Won-Door.
5. Storage pocket.
6. Electronic control box by Won-Door.
7. [Optional key switch by Won-Door.] (See page 33).
8. Two 4" x 4" junction boxes surface mounted side by side on back wall of pocket 12" A.F.F. for required electrical connections.



Brackets [ ] indicate specifier's option  
Note: maximum height for moveable fire walls is 9'-0"



# Won-Door FireGuard MFW

## MFW – ELEVATION FRONT VIEW

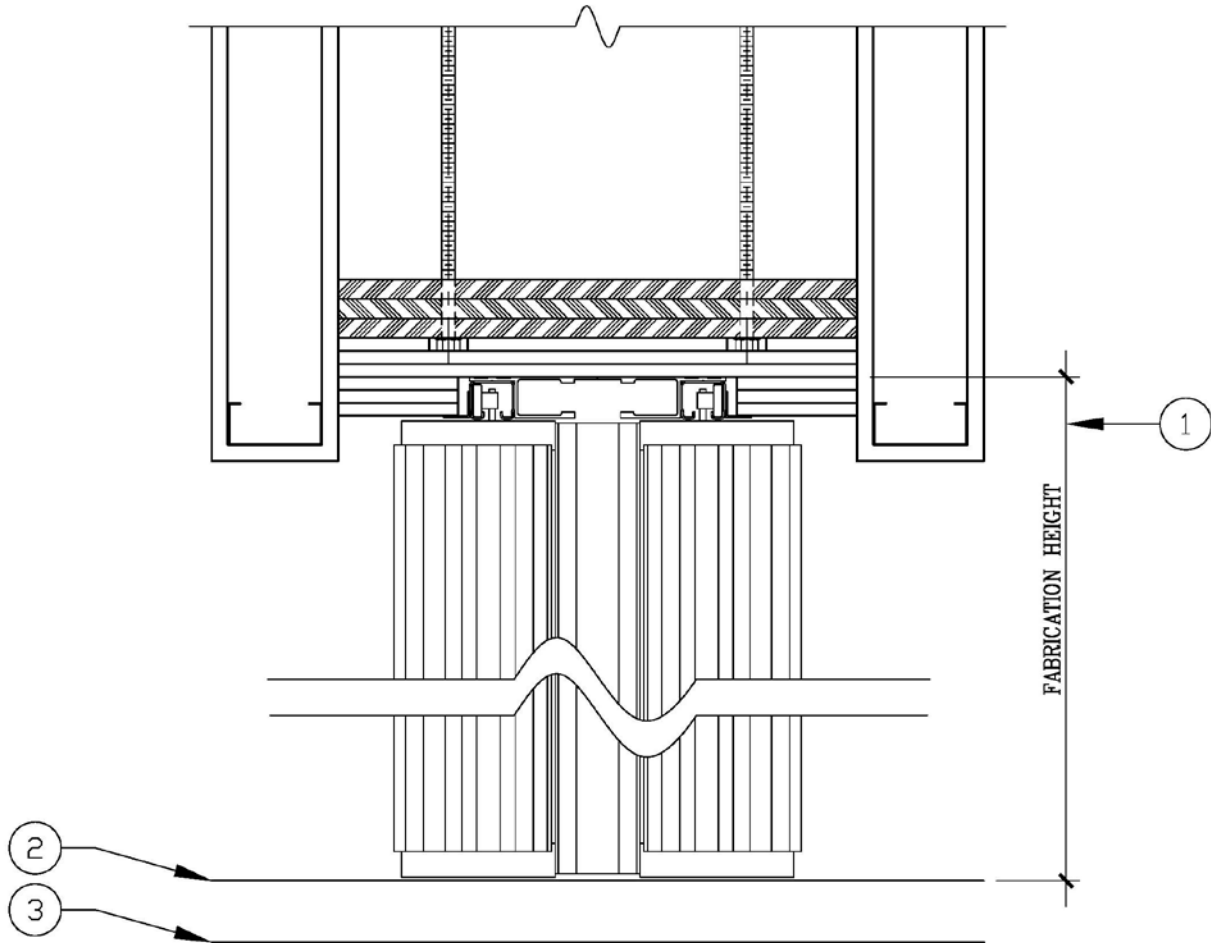

**MFW**  
CAD FILE: MFWELEV2

1. Fabrication height/field dimension height taken from top of track to top of finished floor.
2. Finished Floor. (Carpet, tile, etc.)
3. Sub floor. (Concrete, etc.)

Door Profile Widths:

- Stacked Width: 16"
- Extended Width: 11 1/2"

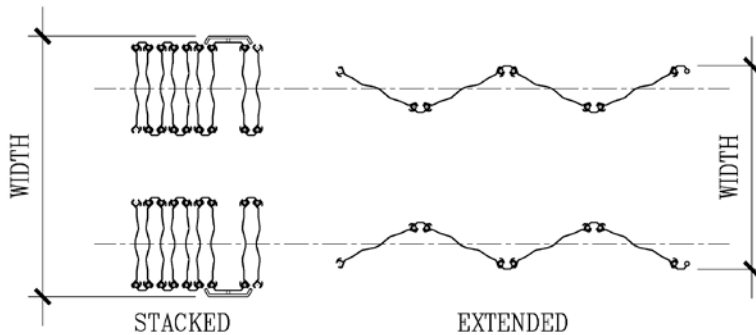

# Won-Door FireGuard MFW

## POCKET DEPTH CHART INSTRUCTIONS

### Moveable Fire Walls

The term CLEAR OPENING WIDTH on the *Pocket Depth Calculation Chart* refers to the distance from the front of the storage pocket to face of the striker.

To determine the pocket depth requirement of a door:

1. Determine the door's CLEAR OPENING WIDTH
2. Find the appropriate range for that width (*From-To* columns)
3. Refer to the "Single" (for single parting) column.
4. Consult the *Options Affecting Pocket Depth* section below the chart to determine how optional equipment affects stack requirements.

**Example below:** Pocket depth for moveable fire walls single parting door w/ 8'-4" clear opening (in the range from 7'-6" to 8'-4"). Minimum pocket depth = 4'-3".

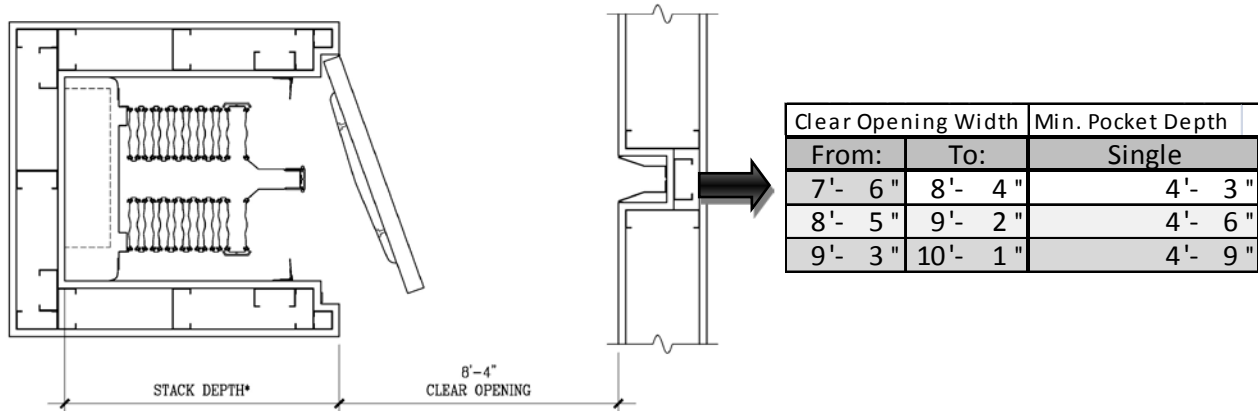

### List of Options Affecting Pocket Depth

Once you have determined the appropriate depth requirements using the chart on the next page, consult the *Options Affecting Pocket Depth* section below the chart. Note that the chart only applies to standard pocket mounted motor Operators with the size limitations listed on the page containing the stack chart. Larger doors will require a Large Door Motor Operator which will affect pocket depth requirements. Optional equipment such as the access control sliding jambs and multiple exit devices will also affect pocket depth as will pocket cover doors in excess of 2" thick.



# Won-Door FireGuard MFW

## POCKET DEPTH CALCULATION CHART

MFW1, MFW2

Clear Opening Width		Pocket Depth
From:	To:	Single Parting
0'-0"	5'-1"	3'-5"
5'-1"	5'-11"	3'-8"
5'-11"	6'-10"	4'-0"
6'-10"	7'-8"	4'-4"
7'-8"	8'-6"	4'-8"
8'-6"	9'-4"	4'-11"
9'-4"	10'-3"	5'-3"
10'-3"	11'-1"	5'-7"
11'-1"	11'-11"	5'-11"
11'-11"	12'-9"	6'-2"
12'-9"	13'-8"	6'-6"
13'-8"	14'-6"	6'-10"
14'-6"	15'-4"	7'-2"
15'-4"	16'-2"	7'-5"
16'-2"	17'-1"	7'-9"
17'-1"	17'-11"	8'-3"
17'-11"	18'-4"	8'-5"
18'-4"	19'-2"	8'-9"
19'-2"	20'-0"	9'-0"

**\*Note:** This chart is for Moveable Fire Walls at a maximum length of 20'-0" and a maximum height of 9'-0". For doors outside of these sizes, please consult the factory. Moveable Fire Walls are not available in bi-parting or curved configurations.

**Limitations and Considerations:**

**Access Control Sliding Jamb:**

Add 1" to stack depth.

**Pocket Cover Door:**

Above charts allow for 2" thick cover door and 1" bumper. Add appropriate amount if cover door and finish materials are thicker than 3".



# Won-Door FireGuard MFW

## POCKET COVER DOOR GUIDELINES

Pocket cover doors are not required, but may be used to aesthetically conceal Won-Door FireGuard doors. When properly done, they add to the continuity of the project and provide anonymity to the installation.

Won-Door Corporation does not manufacture or install pocket cover doors. Therefore, they should be specified in a separate specification section. Unless specifically required by the Authority Having Jurisdiction, pocket doors need not be fire-rated, but solid core doors are preferable for reasons of durability. The door thickness and covering material is at the discretion of the designer. Many covering materials have been successfully used including: plastic laminates, wood veneers, vinyl, paint, bronze, stainless steel, and marble. If the aggregate thickness of the pocket cover door exceeds 2", however, the additional thickness must be added to the calculation of the pocket depth (see *Pocket Depth Calculation Chart* on page 104.)

Some basic criteria for the successful design of pocket cover doors are listed below:

1. Doors must be side hinge swinging and must swing at least 90°. When in the open position, pocket doors may not encroach on the 18" minimum opening width required for the pocket. Designing "notches" on either side of the pocket opening to accommodate the cover door thickness will prevent this (see *Pocket Cover Door Detail* on page 106.)
2. Cover doors must be operable with less than 50 lbs. of lateral force. As the Won-Door FireGuard door is activated, the leading edge will make contact with the cover door and push it open. 50 lbs. is the normal operating force required for egress-type swinging doors and only if the cover door is unusually heavy would special considerations need to be taken.
3. When activated, pocket doors should remain in the open position so as not to obstruct the path of the Won-Door FireGuard door when it is closing.
4. Won-Door recommends specifying either (a) a spring-action such as the Hager #1257 (with reversed spring action) to hold the cover door open when activated **or** (b) a continuous hinge such as a Stanley #314.
  - a. The reversed spring action in the Hager #1257 butt hinge makes the cover door self-opening rather than self-closing. Cover doors without spring action hinges may swing back into the operating path of the Won-Door FireGuard and cause damage or obstruct emergency operation.
  - b. For aesthetic considerations, a continuous hinge is preferable because it does not protrude beyond the face of the pocket cover door and therefore presents a "hinge less" appearance. When a continuous hinge is used, however, a "bumper" is required. The bumper prevents the pocket door from swinging back in to the operating path of the Won-Door FireGuard. Won-door does not provide bumpers, but its design is shown on page 106.
5. A magnetic catch not to exceed 30 lbs. can serve to keep the pocket cover doors in the closed position when the Won-Door FireGuard door is not in use. Positive latches such as hooks or throw bolts are not permitted because they prevent the Won-door FireGuard door from pushing the cover door open during operation.
6. A door frame is not required although one may be used. For aesthetic considerations, however, a "frame less" design may be preferable because it leaves only two slight reveals at the door edges and provides a less noticeable pocket door installation.



# Won-Door FireGuard MFW

## POCKET COVER DOOR DETAILS

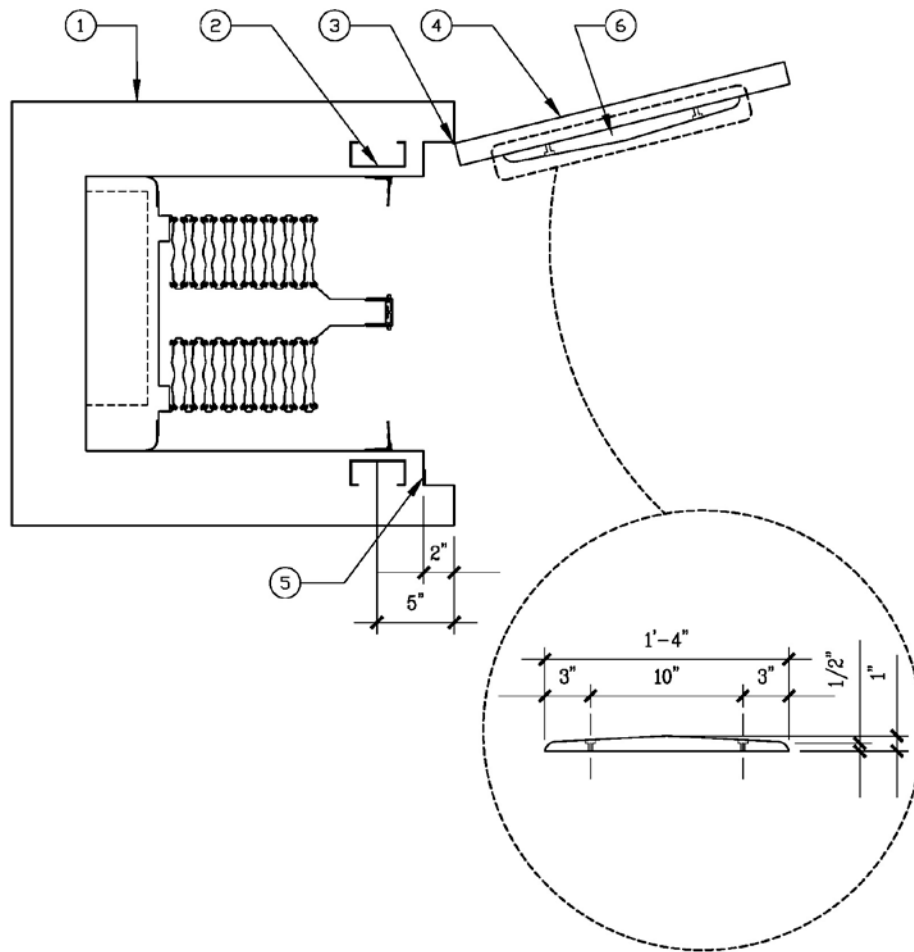

1. Provide fire rated construction corresponding to rating required for opening by others. (1 hour construction shown).
2. Blocking for sliding jamb stops centered at 5" from face of pocket by others.
3. Spring action hinge or continuous hinge by others.
4. Non-rated pocket cover door by others.
5. Magnetic catch (not to exceed 30 lbs.) by others.
6. Bumper (mounted on inside of pocket cover door 3" above finished floor) by others.



Bumpers must be specified when non-spring action hinges are used.



# Won-Door FireGuard MFW

## POCKET MOUNTED MOTOR OPERATOR ELECTRICAL DIAGRAM

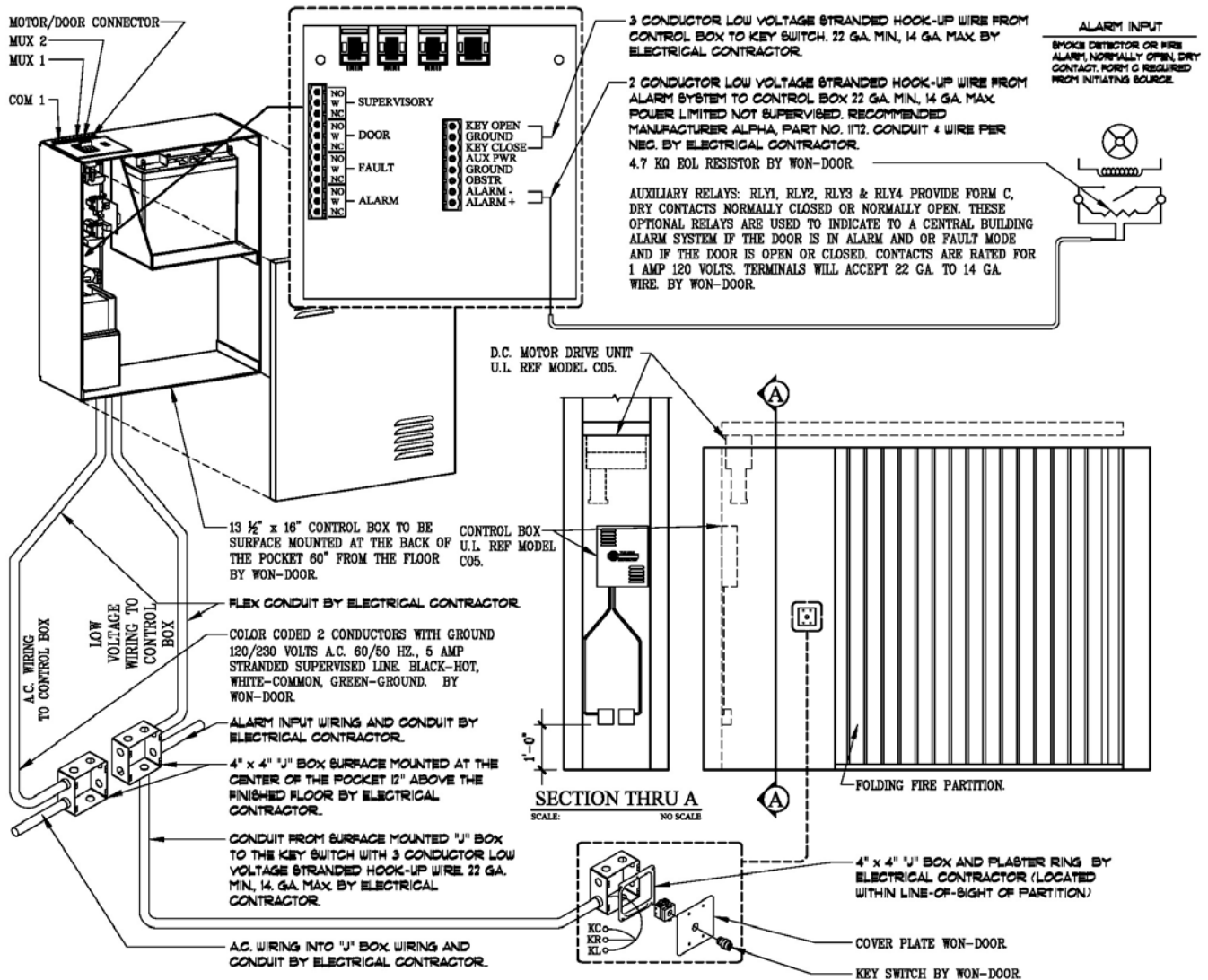

### POCKET MOUNTED MOTOR

CAD FILE: MFWELEC1

Specifier's note

Note: Cable lengths referred to in this detail are actual cable lengths, not straight line distances. If cable length exceeds 25 wire feet, consult the factory.



# Won-Door FireGuard MFW

## OPTIONAL KEY SWITCH

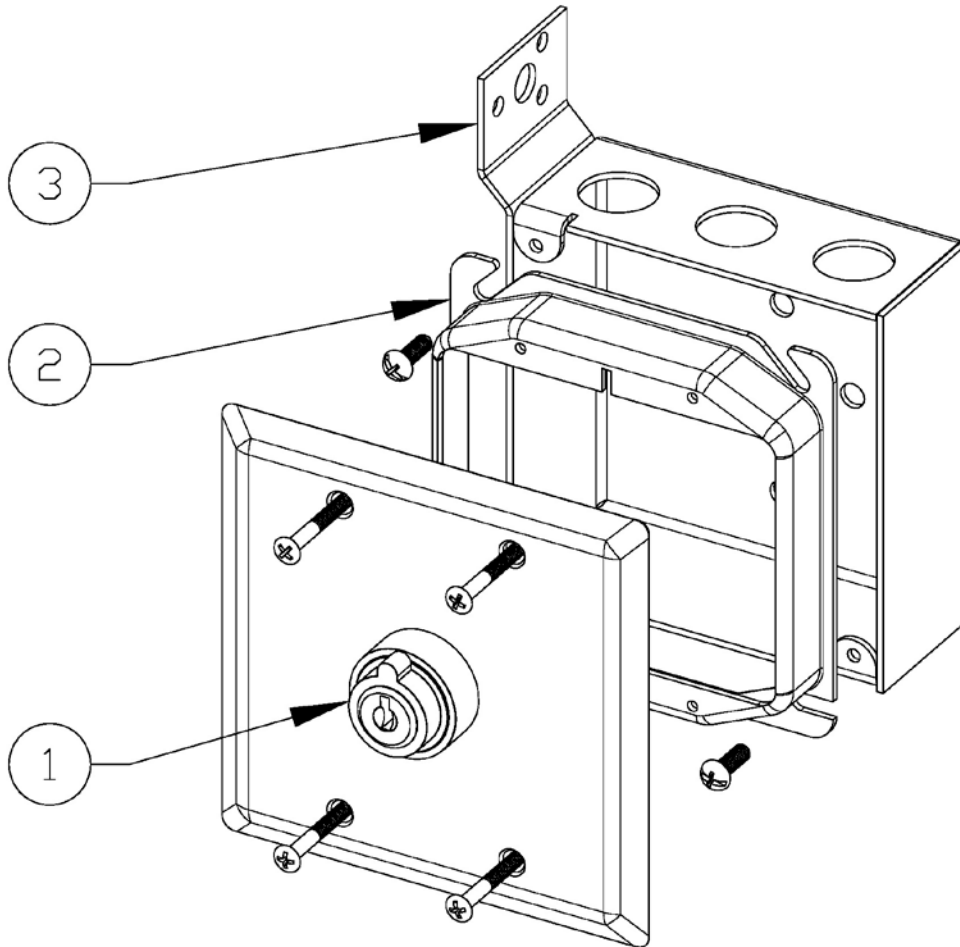

1. Key switch module.
2. Plaster ring by others.
3. 4" x 4" x 2 1/2" electrical box by others.



One (1) key switch is provided with each motor operated partition. Additional key switches must be specified. For safety reasons, a key switch must be located within line-of-sight of the entire door opening.



# Won-Door DuraSound

## SECTION: 10 22 26.13 ACCORDION FOLDING PARTITIONS

### PART 1 – GENERAL

#### 1.01 SUMMARY OF WORK

- A. Division 0 and Division 1, as indexed, apply to this section.
- B. Furnish and install all accordion folding partitions shown on the drawings and specified herein.

#### 1.02 RELATED SECTIONS

- A. All headers, support structures, surrounding insulation, jambs, pocket doors, blocking and trim shall be furnished and installed by other sections.
- B. **OPTION:** If Section 2.02 J is specified, the following paragraph should be included: All electrical work including but not limited to the following electrical work by Electrical Section:
  - 1. Provide 115/230 volt single-phase (or 208 volt, 3-phase A.C.) electrical service in conduit to the reversing magnetic starter.
  - 2. Provide 115/230 volt single-phase (or 208 volt, 3-phase A.C.) electrical service between the starter and the gear motor.
  - 3. Provide 4" x 4" electrical box for the key switch located within line-of-sight of the folding partition.
  - 4. Provide 3-conductor, 18-gauge stranded wire in conduit between the key switch and starter.
  - 5. Provide key switch for door operation (3 position switch, spring return to center from right or left).

#### 1.03 QUALITY ASSURANCE

- A. Installation shall be accomplished by factory trained personnel.
- B. Sound rated partitions shall have the laboratory sound rating indicated, when tested in accordance with the requirements of ASTM E-90.

#### 1.04 SUBMITTALS

- A. Refer to Section 01 30 00 – Shop Drawings and Submittals.
- B. Indicate required stacking depth, pocket width (if applicable) and height of header above finished floor. Show installation details, layout and any optional electrical requirements.

#### 1.05 DELIVERY, STORAGE AND HANDLING

- A. Deliver to job site in manufacturer's original, unopened package.

#### 1.06 COORDINATION BY GENERAL CONTRACTOR

- A. Coordinate the efforts of the various trades affected by the work of this section. Assure accurate installation of header, jamb and trim. Provide "As-Built" dimensions for opening and storage pocket.
- B. Supervise unloading and handling. Store boxes flat (no more than three high) in a dry area and protect from elements that may damage materials. Replace damaged materials at no additional cost to the owner.



# Won-Door DuraSound

- C. **OPTION:** When Section 2.02 J is specified, the following paragraph should be included: Permanent power shall be in place for final connection when partitions are erected. Assure access to and proper clearance for motor operators.

## 1.07 WARRANTY

- A. Materials shall be warranted against defects and workmanship for a period of one (1) year from the date of substantial completion.

## PART 2 – PRODUCTS

### 2.01 MANUFACTURER

- A. Folding partitions shall be DuraSound as manufactured by Won-Door Corporation, Salt Lake City, Utah.

### 2.02 MATERIALS

- A. Operation: Shall be top supported and manually operated.
- B. Construction: Shall consist of two parallel accordion-type walls of panels independently suspended with no pantographs or interconnections except at the lead-post.
- C. Panels shall be formed of cold rolled vinyl-clad 24-gauge V-grooved steel. Vinyl shall be permanently bonded by heat pressure lamination to the steel panel. Panels shall be connected by full height extruded vinyl hinges.
- D. Insulation: Interior surfaces of both walls shall be completely covered with a continuous blanket of 2 lb. density foil-backed fiberglass fastened in place with steel spring-clips.
- E. Suspension systems: Shall consist of two extruded aluminum tracks spaced 6” or 8” on center attached to the overhead structural support. Each panel shall be suspended by a steel hanger pin and a pair of nylon-tired ball bearing rollers. Each lead-post shall be suspended by an 4-wheel ball bearing trolley.
- F. Lead-posts: Shall be of 16-gauge cold rolled steel and shall be connected to the partition by specially formed steel panels. Lead-post hardware shall include standard grip-type handles and sliding latch to affect closure.
- G. Perimeter Seals: Shall consist of continuous extruded vinyl sweep strips attached to the top and bottom of the partition. Leading edges of lead-posts and receiver posts shall be acoustically sealed by extruded vinyl interlocking seals.
- H. Hanging weight shall be 4.2 pounds per square foot.
- I. **OPTION:** Stabilizer Bar: Shall consist of a top supported, internally mounted diagonal brace connected to the lead-post for proper alignment during operation and latching. (Requires 14” wide header. Required on all doors over 14’-0” high.)
- J. **OPTION:** Motor Operator:
1. Operation: Motor-operated folding partitions shall be driven by means of a roller chain attached to the stabilizer bar trolley. An internally mounted stabilizer bar shall keep lead posts plumb and in proper alignment during operation and insure a tight fitting closure without the use of mechanical latches.
  2. Assembly: Shall consist of a 115/230 volt single-phase A.C. motor or 208 volt 3-phase A.C. gear motor, reversing electromagnetic starter, and limit switch. Size of each motor shall be determined by manufacturer to insure proper operation.



# Won-Door DuraSound

K. **OPTION:** Key Locks: Key locks shall be provided by manufacturer.

## 2.03 ACOUSTICAL PERFORMANCE

A. Sound transmission class (STC) shall be STC 48 when tested in accordance with requirements of ASTM E-90.

## 2.04 COLORS

A. Vinyl finish color shall be selected by the architect from manufacturer's standard colors.

## PART 3 – EXECUTION

### 3.01 PREPARATION BY GENERAL CONTRACTOR

A. Openings shall be to the dimensions specified, plumb and level.

B. Headers shall be parallel with the finished floor to within  $\pm 1/4$ " tolerance over the entire length of the opening.

### 3.02 INSPECTION

A. Contractor shall inspect prepared opening and immediately notify the architect, in writing, of unacceptable conditions.

### 3.03 INSTALLATION

A. Install partitions in accordance with manufacturer's printed instructions.

B. Upon completion of the installation, the General Contractor shall protect partitions from damage and replace or repair subsequent damage so that partitions are acceptable to the architect, at no additional cost to the owner.

Copyright © 2013 by Won-Door Corporation, all rights reserved.

END OF SECTION



# Won-Door DuraSound

This page intentionally left blank.



# Won-Door DuraSound

## STRAIGHT DOOR – HEAD DETAIL UNDER 14'-0" IN HEIGHT – MANUAL OPERATION

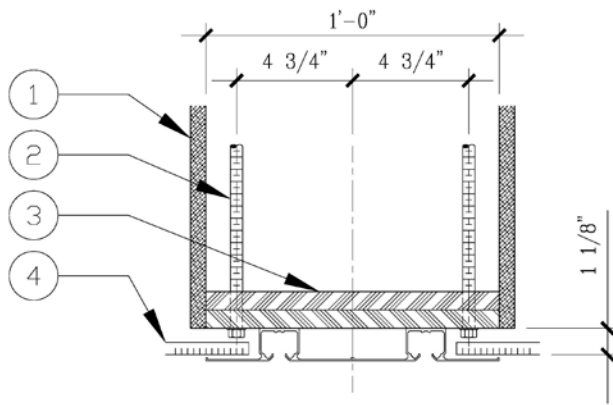

**STANDARD T-11 TRACK**  
CAD FILE: DSHD1

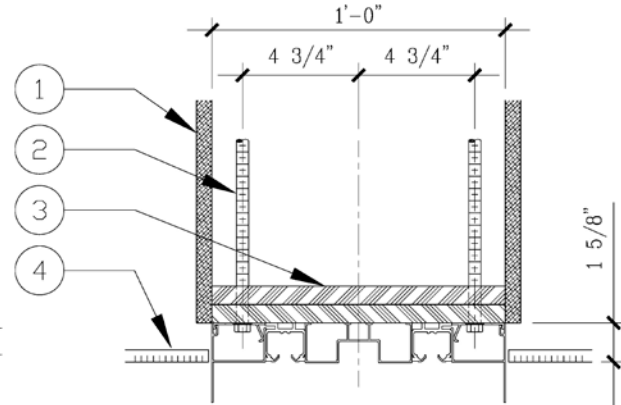

**T-09 TRACK w/PVC SOFFIT**  
CAD FILE: DSHD2

1. Insulate as required for sound attenuation by others.
2. 1/2" threaded rod, nuts, and washers by others (24" O.C. in opening, 12" O.C. in stack area).
3. Two layers 3/4" x 12" x continuous plywood, to be parallel with floor with maximum tolerance of  $\pm 1/4$ " by others.
4. Ceiling by others. (Ceiling not supported by Won-Door PVC soffit).
5. 1 1/2" x 2 1/8" wood trim by others.

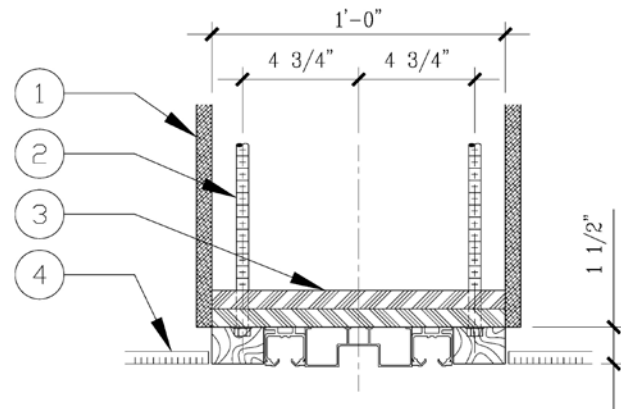

**T-09 TRACK w/WOOD TRIM**  
CAD FILE: DSHD3

Specifier's  
note

\*Folding partitions greater than 14' in height require an internal stabilizer bar to keep the lead-post plumb during operation. In order to allow adequate space within the partition for the stabilizer bar, a 14" wide header is required.



# Won-Door DuraSound

## STRAIGHT DOOR – HEAD DETAIL OVER 14'-0" IN HEIGHT – MANUAL OPERATION

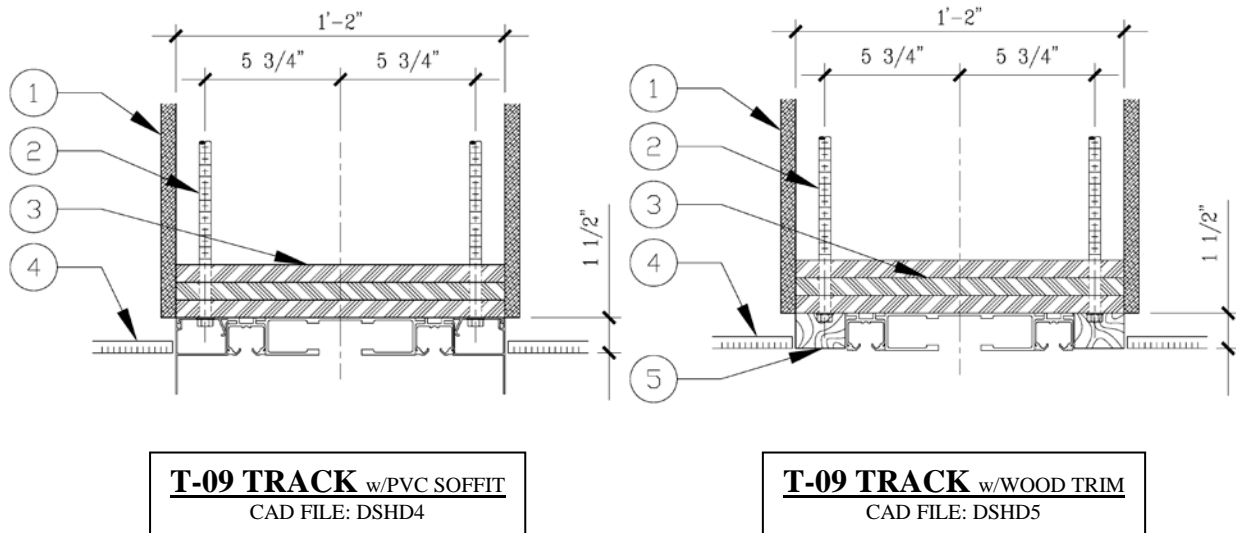

1. Insulate as required for sound attenuation by others.
2. 1/2" threaded rod, nuts, and washers by others (24" O.C. in opening, 12" O.C. in stack area).
3. Three layers 3/4" x 14" x continuous plywood, to be parallel with floor with maximum tolerance of  $\pm 1/4$ " by others.
4. Ceiling by others. (Ceiling not supported by Won-Door PVC soffit).
5. 1 1/2" x 2 1/8" wood trim by others.



\*Folding partitions greater than 14' in height require an internal stabilizer bar to keep the lead-post plumb during operation. In order to allow adequate space within the partition for the stabilizer bar, a 14" wide header is required.



# Won-Door DuraSound

## STRAIGHT DOOR – HEAD DETAIL MOTORIZED OPERATION

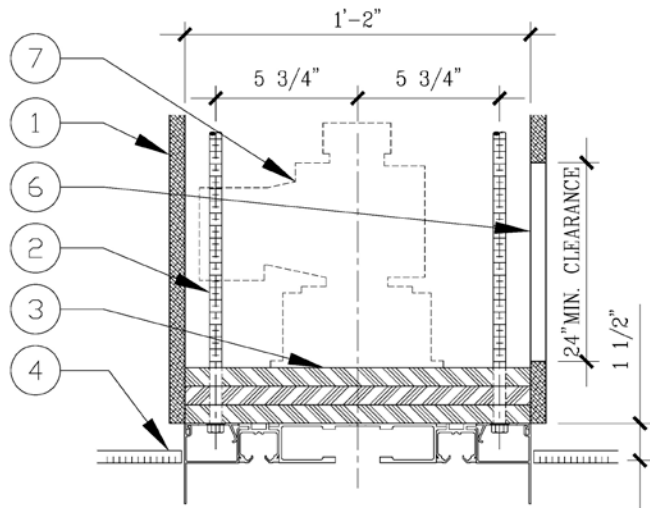

**T-09 TRACK** w/PVC SOFFIT  
CAD FILE: DSHD6

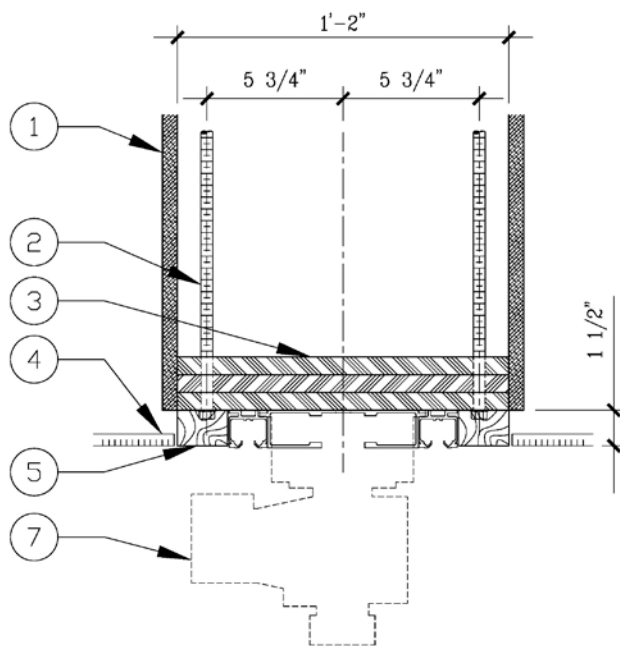

**T-09 TRACK** w/WOOD TRIM  
CAD FILE: DSHD7

1. Insulate as required for sound attenuation by others.
2. 1/2" threaded rod, nuts, and washers by others (24" O.C. in opening, 12" O.C. in stack area).
3. Three layers 3/4" x 14" x continuous plywood, to be parallel with floor with maximum tolerance of  $\pm 1/4$ " by others.
4. Ceiling by others. (Ceiling not supported by Won-Door PVC soffit).
5. 1 1/2" x 2 1/8" wood trim by others.
6. 24" x 24" access for installation and service of motor by others.
7. AC electric motor assembly. (Motor can be mounted above or below the header.) See page 127 for details about location.



# Won-Door DuraSound

## CURVED DOOR – HEAD DETAIL MANUAL & MOTORIZED OPERATION

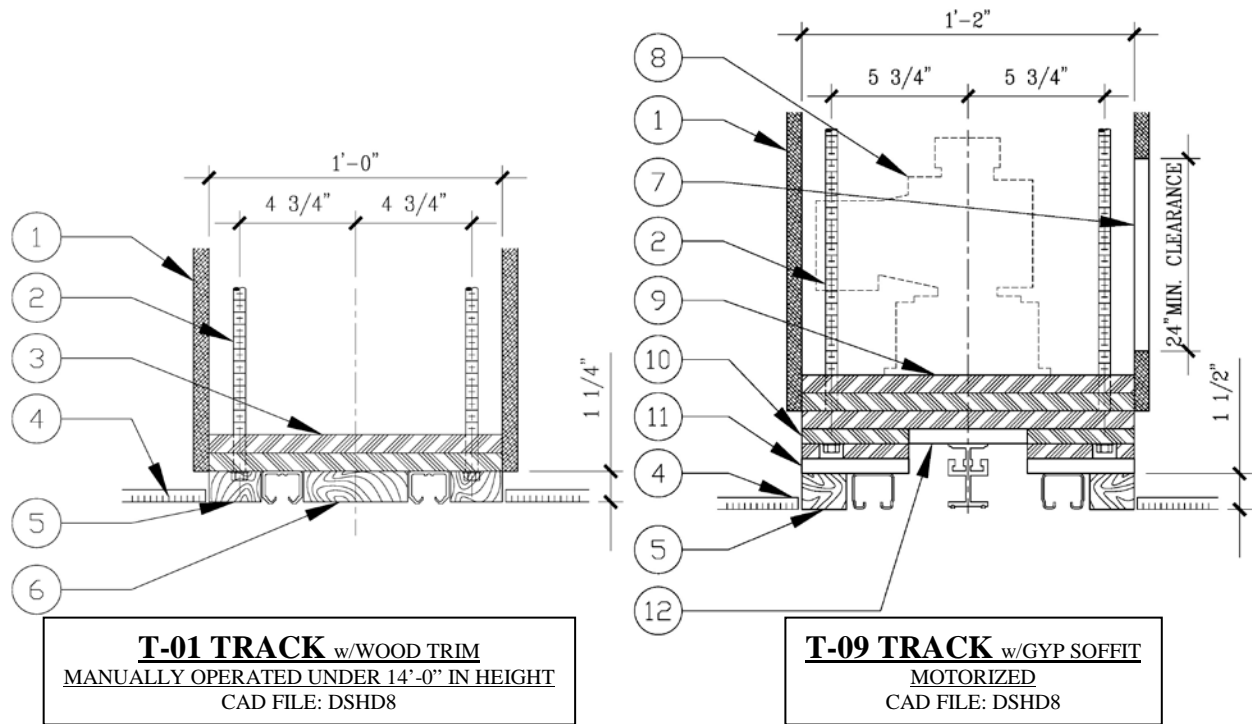

1. Insulate as required for sound attenuation by others.
2. 1/2" threaded rod, nuts, and washers by others (24" O.C. in opening, 12" O.C. in stack area).
3. Two layers 3/4" x 14" x continuous plywood, to be parallel with floor with maximum tolerance of ±1/4" by others.
4. Ceiling by others. (Ceiling not supported by Won-Door PVC soffit).
5. 1 1/2" x 2 1/8" wood trim by others.
6. 1 1/2" x 4 1/4" wood trim by others.
7. 24" x 24" access for installation and service of motor by others.
8. AC electric motor assembly. (Motor can be mounted above or below the header.) See page 127 for details about location.
9. Three layers 3/4" x 14" x continuous plywood, to be parallel with floor with maximum tolerance of ±1/4" by others.
10. Two layers 5/8" x 4 1/2" x continuous plywood by others.
11. One layer 5/8" x 4 1/2" x continuous gypsum furnished and finished by others.
12. One layer 5/8" x 5" x continuous gypsum furnished and finished by others.

Specifier's  
note

\*Minimum radius for a manually operated curved DuraSound partition is 4'-0".  
Minimum radius for a motorized curved DuraSound partition is 5'-0".





# Won-Door DuraSound

## PLAN VIEW – MANUAL OPERATION

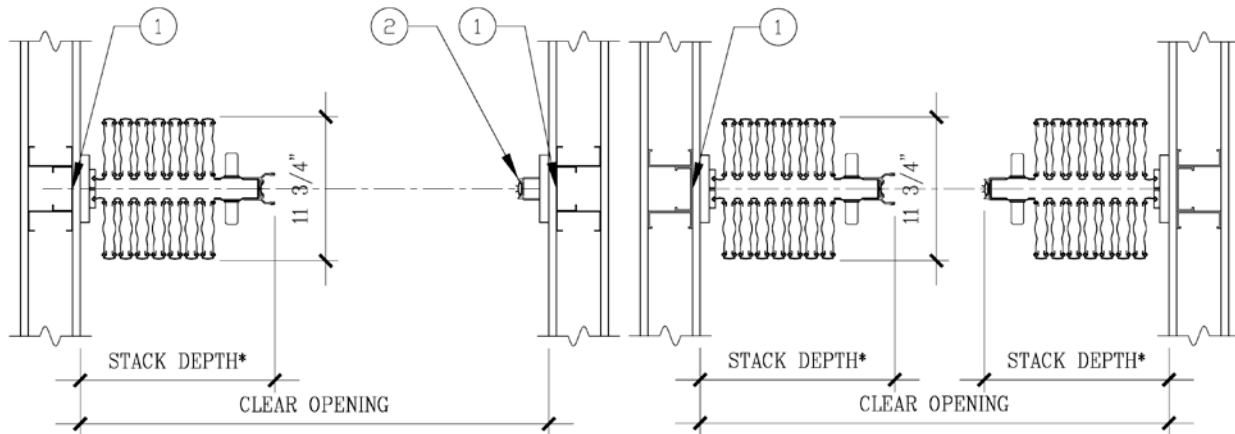

### **SINGLE PARTING** w/FIXED JAMB

\*Stack Depth= (opening in feet x 1.75"/ft.)+6"  
CAD FILE: DSPL1

### **BI-PARTING** w/FIXED JAMB

\*Stack Depth= (1/2 opening in feet x 1.75"/ft.)+6"  
CAD FILE: DSPL2

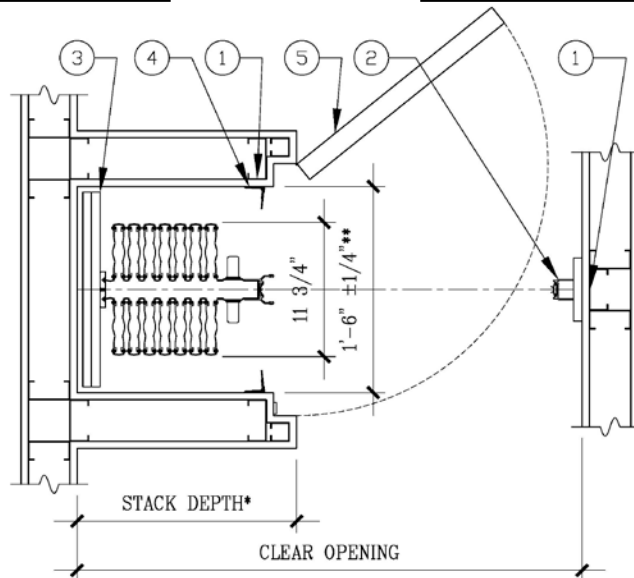

### **SINGLE PARTING** w/FLOATING JAMB

\*Stack Depth= (opening in feet x 1.75"/ft.)+9"+pocket door thickness  
CAD FILE: DSPL3

1. Blocking by others.
2. Aluminum striker by Won-Door.
3. Floating jamb by Won-Door.
4. Floating jamb stops by Won-Door.
5. [Optional pocket cover door by others.]

Specifier's  
note

Brackets [ ] indicate specifier's option

\*Minimum stack depth for a motorized DuraSound is 56"

\*\*Pocket width shown is for doors taller than 15'-0". For doors taller than 15'-0", consult the factory.



# Won-Door DuraSound

## PLAN VIEW – MOTORIZED OPERATION

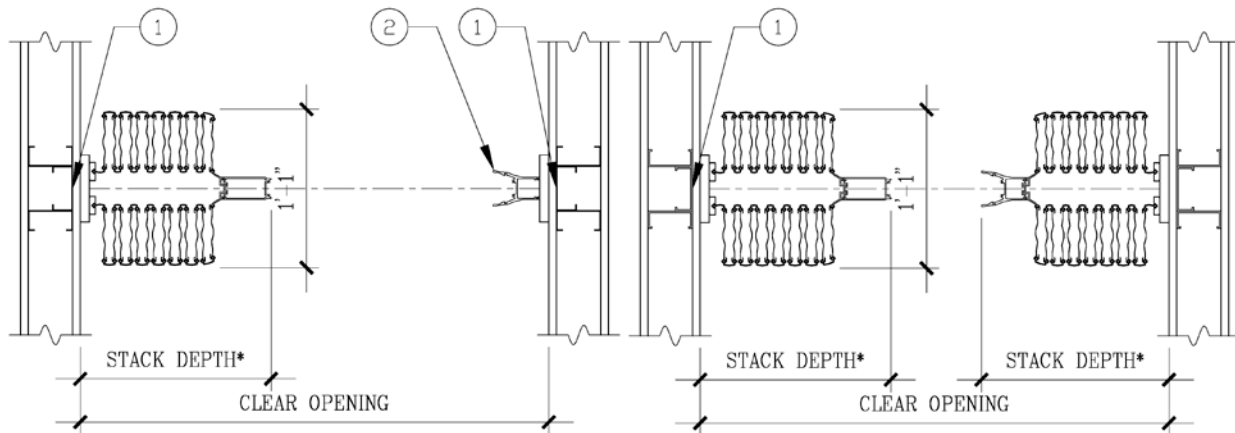

### **SINGLE PARTING** w/FIXED JAMB

\*Stack Depth= (opening in feet x 1.75"/ft.)+6"  
CAD FILE: DSPL4

### **BI-PARTING** w/FIXED JAMB

\*Stack Depth= (1/2 opening in feet x 1.75"/ft.)+6"  
CAD FILE: DSPL5

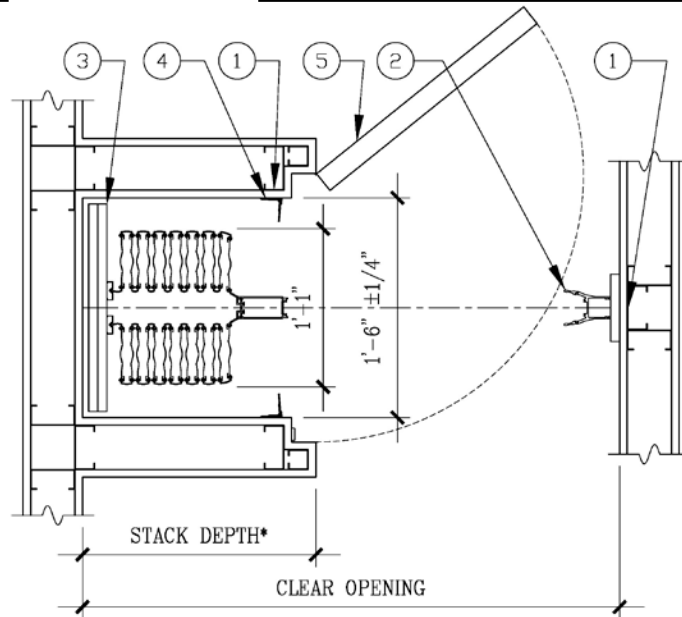

### **SINGLE PARTING** w/FLOATING JAMB

\*Stack Depth= (opening in feet x 1.75"/ft.)+9"+pocket door thickness  
CAD FILE: DSPL6

1. Blocking by others.
2. Aluminum striker by Won-Door.
3. Floating jamb by Won-Door.
4. Floating jamb stops by Won-Door.
5. [Optional pocket cover door by others.]



Brackets [ ] indicate specifier's option

\*Minimum stack depth for a motorized DuraSound is 56".

\*\*Pocket width shown is for doors taller than 15'-0". For doors taller than 15'-0", consult the factory.



# Won-Door DuraSound

## ELEVATION – SIDE VIEW MANUAL OPERATION

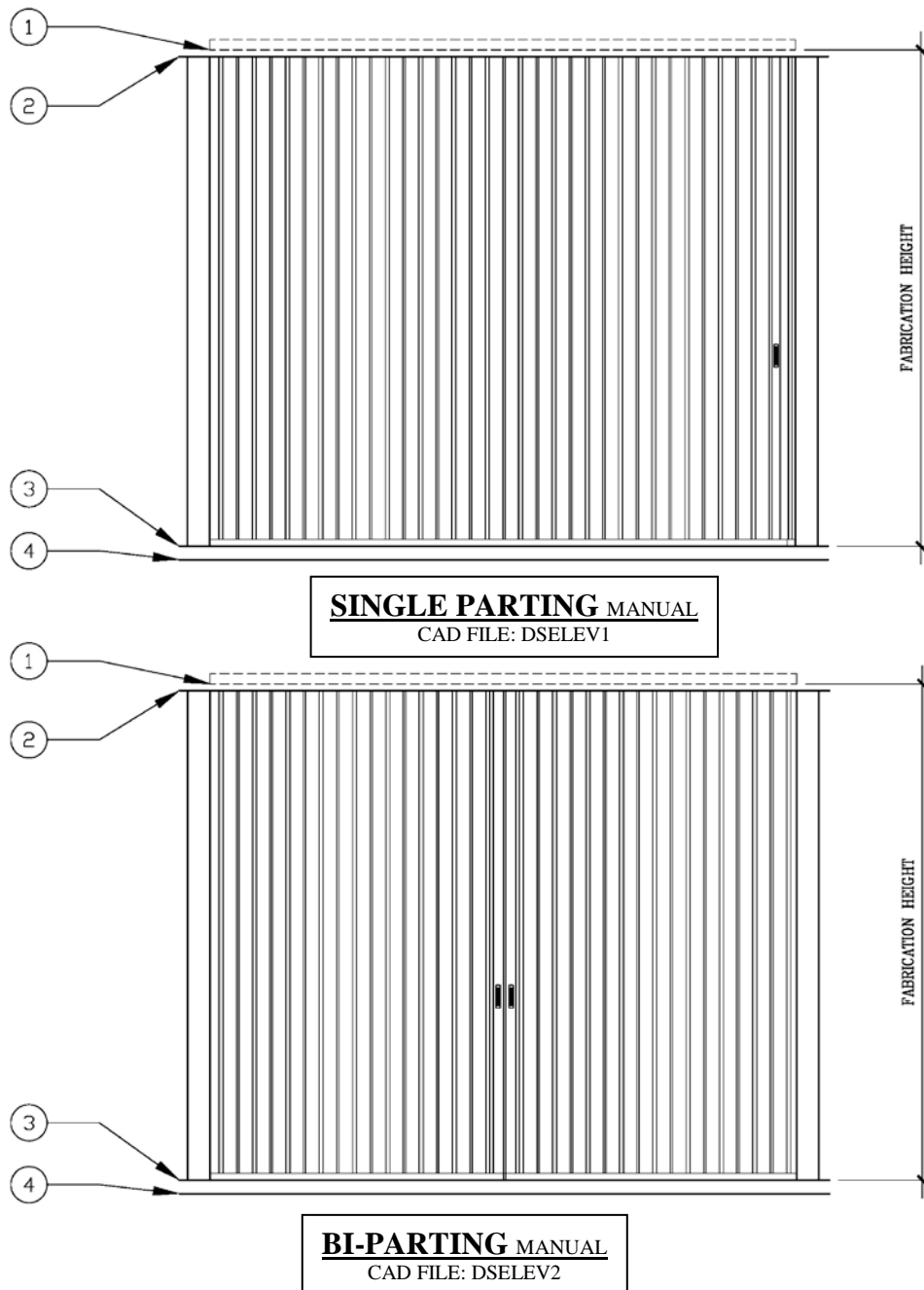

1. Bottom of header.
2. Ceiling line.
3. Top of finished floor (carpet, tile, etc.)
4. Sub floor (concrete, etc.)



# Won-Door DuraSound

## ELEVATION – SIDE VIEW MOTORIZED OPERATION

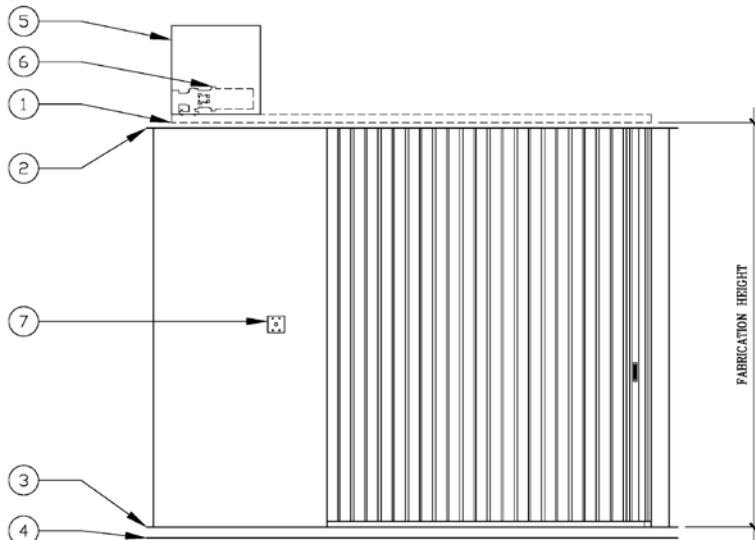

**SINGLE PARTING** MOTORIZED  
CAD FILE: DSELEV3

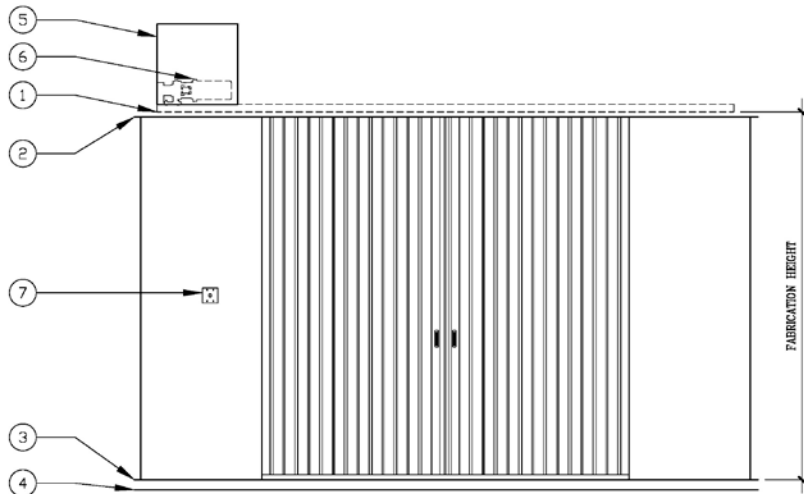

**BI-PARTING** MOTORIZED  
CAD FILE: DSELEV4

1. Bottom of header.
2. Ceiling line.
3. Top of finished floor (carpet, tile, etc.)
4. Sub floor (concrete, etc.)
5. AC motor operator by Won-Door. (Motor may be located above or below header).
6. 24" x 24" access by others.
7. Key switch by Won-Door. (Must be located within line-of-sight of the entire door opening). (See page 128).



Brackets [ ] indicate specifier's option  
For motorized bi-parting doors, a motor operator is located at one end only. For motorized un-equal bi-parting doors, motor operators and access are required at both ends.



# Won-Door DuraSound

## ELEVATION – FRONT VIEW MANUAL OPERATION

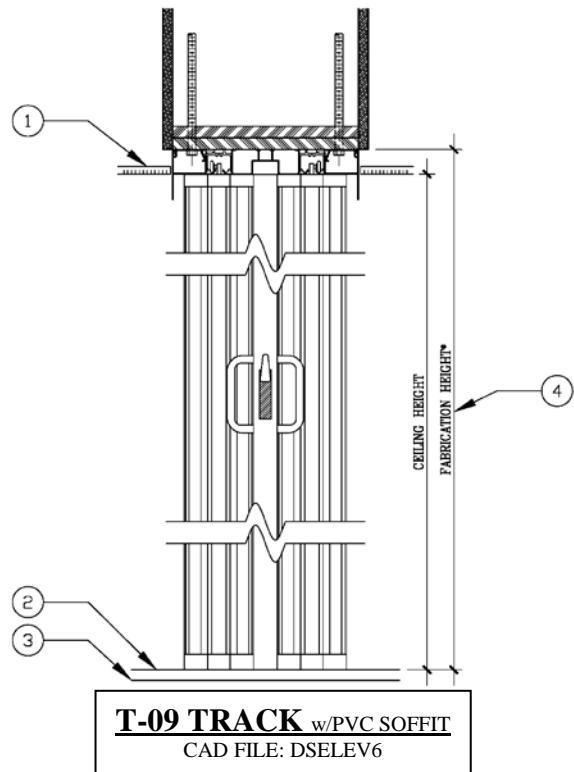
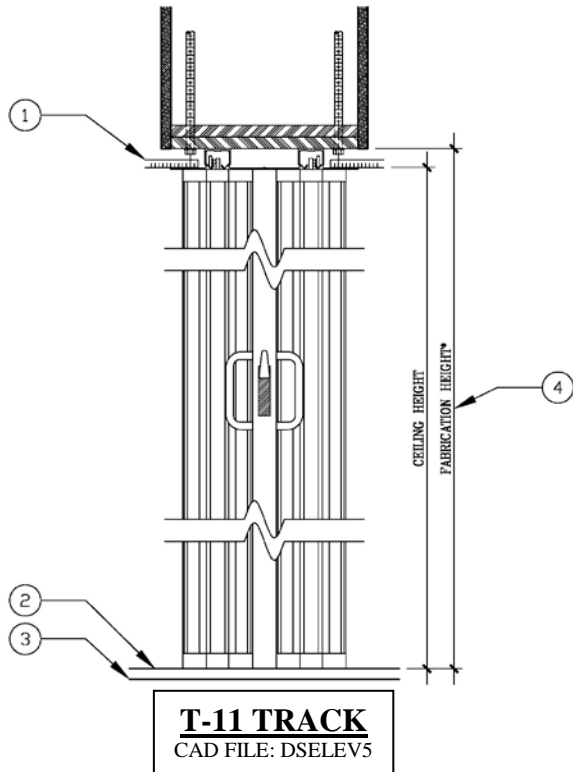

1. Ceiling by others (not supported by PVC soffit)
2. Top of finished floor (carpet, tile, etc.)
3. Sub floor (concrete, etc.)
4. Fabrication height. \*Field dimension taken from top of track to top of finished floor.

### Door Profile Widths:

- Manually operated doors below 14'-0" in height:
  - Stacked width: 11 3/4"
  - Extended width: 9 1/2"
- All motorized doors and manual doors above 14'-0" in height:
  - Stacked width: 13 3/4"
  - Extended width: 11 1/2"

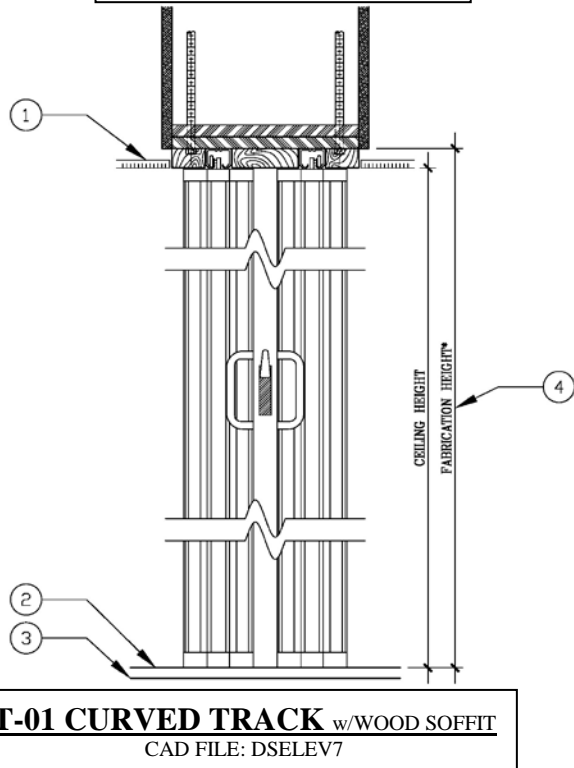
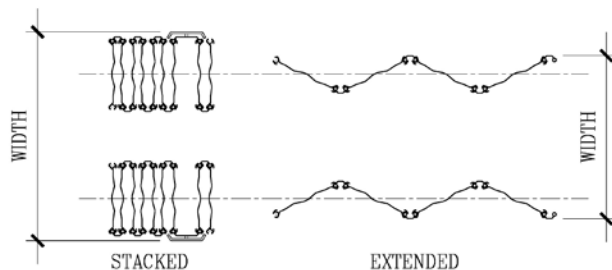

# Won-Door DuraSound

## DURASOUND – POCKET DEPTH CALCULATION CHART MANUALLY OPERATED

Clear Opening Width		Pocket Depth
From:	To:	
3'-0"	3'-5"	1'-0"
3'-6"	3'-11"	1'-1"
4'-0"	4'-7"	1'-3"
4'-8"	5'-3"	1'-4"
5'-4"	5'-11"	1'-5"
6'-0"	6'-7"	1'-6"
6'-8"	7'-3"	1'-7"
7'-4"	7'-11"	1'-8"
8'-0"	8'-7"	1'-10"
8'-8"	9'-3"	1'-11"
9'-4"	9'-11"	2'-0"
10'-0"	10'-7"	2'-1"
10'-8"	11'-3"	2'-2"
11'-4"	11'-11"	2'-3"
12'-0"	12'-7"	2'-5"
12'-8"	13'-3"	2'-6"
13'-4"	13'-11"	2'-7"
14'-0"	14'-7"	2'-8"
14'-8"	15'-3"	2'-9"
15'-4"	15'-11"	2'-10"
16'-0"	16'-7"	3'-0"
16'-8"	17'-3"	3'-1"
17'-4"	17'-11"	3'-2"
18'-0"	18'-7"	3'-3"
18'-8"	19'-3"	3'-4"
19'-4"	19'-11"	3'-5"
20'-0"	20'-7"	3'-7"
20'-8"	21'-3"	3'-8"
21'-4"	21'-11"	3'-9"
22'-0"	22'-7"	3'-10"
22'-8"	23'-3"	3'-11"
23'-4"	23'-11"	4'-0"
24'-0"	24'-7"	4'-2"
24'-8"	25'-3"	4'-3"
25'-4"	25'-11"	4'-4"
26'-0"	26'-7"	4'-5"
26'-8"	27'-3"	4'-6"
27'-4"	27'-11"	4'-7"
28'-0"	28'-7"	4'-9"
28'-8"	29'-3"	4'-10"
29'-4"	29'-11"	4'-11"
30'-0"	30'-5"	5'-0"

\*For bi-parting doors: Use 1/2 the clear opening width.

Clear Opening Width		Pocket Depth
From:	To:	
30'-6"	31'-1"	5'-1"
31'-2"	31'-9"	5'-2"
31'-10"	32'-5"	5'-3"
32'-6"	33'-1"	5'-4"
33'-2"	33'-9"	5'-6"
33'-10"	34'-5"	5'-7"
34'-6"	35'-1"	5'-8"
35'-2"	35'-9"	5'-9"
35'-10"	36'-5"	5'-10"
36'-6"	37'-1"	5'-11"
37'-2"	37'-9"	6'-1"
37'-10"	38'-5"	6'-2"
38'-6"	39'-1"	6'-3"
39'-2"	39'-9"	6'-4"
39'-10"	40'-5"	6'-5"
40'-6"	41'-1"	6'-6"
41'-2"	41'-9"	6'-8"
41'-10"	42'-5"	6'-9"
42'-6"	43'-1"	6'-10"
43'-2"	43'-9"	6'-11"
43'-10"	44'-5"	7'-0"
44'-6"	45'-1"	7'-1"
45'-2"	45'-9"	7'-3"
45'-10"	46'-5"	7'-4"
46'-6"	47'-1"	7'-5"
47'-2"	47'-9"	7'-6"
47'-10"	48'-5"	7'-7"
48'-6"	49'-1"	7'-8"
49'-2"	49'-9"	7'-10"
49'-10"	50'-5"	7'-11"
50'-6"	51'-1"	8'-0"
51'-2"	51'-9"	8'-1"
51'-10"	52'-5"	8'-2"
52'-6"	53'-1"	8'-3"
53'-2"	53'-9"	8'-5"
53'-10"	54'-5"	8'-6"
54'-6"	55'-1"	8'-7"
55'-2"	55'-9"	8'-8"
55'-10"	56'-5"	8'-9"
56'-6"	56'-11"	8'-10"
57'-0"	57'-7"	8'-11"
57'-8"	58'-3"	9'-0"

### OPTIONS AFFECTING POCKET DEPTH:

Maximum square feet for manually operated door: 400 sq. ft.

For with floating jamb add 3".

For doors with pocket cover door add 2".

For doors over 14' in height, minimum pocket depth is: 3'-2".

For other options such as multi-meeting post, rolling post or motorized doors, consult the factory.



# Won-Door DuraSound

## DURASOUND – POCKET DEPTH CALCULATION CHART MOTOR OPERATED

Clear Opening Width		Pocket Depth
From:	To:	
3'-0"	28'-1"	4'-8"
28'-2"	28'-7"	4'-9"
28'-8"	29'-3"	4'-10"
29'-4"	29'-11"	4'-11"
30'-0"	30'-7"	5'-0"
30'-8"	31'-3"	5'-1"
31'-4"	31'-11"	5'-2"
32'-0"	32'-7"	5'-4"
32'-8"	33'-3"	5'-5"
33'-4"	33'-11"	5'-6"
34'-0"	34'-7"	5'-7"
34'-8"	35'-3"	5'-8"
35'-4"	35'-11"	5'-9"
36'-0"	36'-7"	5'-11"
36'-8"	37'-3"	6'-0"
37'-4"	37'-11"	6'-1"
38'-0"	38'-7"	6'-2"
38'-8"	39'-3"	6'-3"
39'-4"	39'-11"	6'-4"
40'-0"	40'-7"	6'-6"
40'-8"	41'-3"	6'-7"
41'-4"	41'-11"	6'-8"
42'-0"	42'-7"	6'-9"
42'-8"	43'-3"	6'-10"
43'-4"	43'-11"	6'-11"
44'-0"	44'-7"	7'-1"
44'-8"	45'-3"	7'-2"
45'-4"	45'-11"	7'-3"
46'-0"	46'-7"	7'-4"
46'-8"	47'-3"	7'-5"
47'-4"	47'-11"	7'-6"
48'-0"	48'-7"	7'-8"
48'-8"	49'-3"	7'-9"
49'-4"	49'-11"	7'-10"
50'-0"	50'-7"	7'-11"
50'-8"	51'-3"	8'-0"
51'-4"	51'-11"	8'-1"
52'-0"	52'-7"	8'-3"
52'-8"	53'-3"	8'-4"
53'-4"	53'-11"	8'-5"
54'-0"	54'-7"	8'-6"
54'-8"	55'-1"	8'-7"

\*For bi-parting doors: Use 1/2 the clear opening width.

Clear Opening Width		Pocket Depth
From:	To:	
55'-2"	55'-9"	8'-8"
55'-10"	56'-5"	8'-9"
56'-6"	57'-1"	8'-10"
57'-2"	57'-9"	9'-0"
57'-10"	58'-5"	9'-1"
58'-6"	59'-1"	9'-2"
59'-2"	59'-9"	9'-3"
59'-10"	60'-5"	9'-4"
60'-6"	61'-1"	9'-5"
61'-2"	61'-9"	9'-7"
61'-10"	62'-5"	9'-8"
62'-6"	63'-1"	9'-9"
63'-2"	63'-9"	9'-10"
63'-10"	64'-5"	9'-11"
64'-6"	65'-1"	10'-0"
65'-2"	65'-9"	10'-2"
65'-10"	66'-5"	10'-3"
66'-6"	67'-1"	10'-4"
67'-2"	67'-9"	10'-5"
67'-10"	68'-5"	10'-6"
68'-6"	69'-1"	10'-7"
69'-2"	69'-9"	10'-9"
69'-10"	70'-5"	10'-10"
70'-6"	71'-1"	10'-11"
71'-2"	71'-9"	11'-0"
71'-10"	72'-5"	11'-1"
72'-6"	73'-1"	11'-2"
73'-2"	73'-9"	11'-4"
73'-10"	74'-5"	11'-5"
74'-6"	75'-1"	11'-6"
75'-2"	75'-9"	11'-7"
75'-10"	76'-5"	11'-8"
76'-6"	77'-1"	11'-9"
77'-2"	77'-9"	11'-11"
77'-10"	78'-5"	12'-0"
78'-6"	79'-1"	12'-1"
79'-2"	79'-9"	12'-2"
79'-10"	80'-5"	12'-3"
80'-6"	81'-1"	12'-4"
81'-2"	81'-9"	12'-5"
81'-8"	82'-3"	12'-6"
82'-4"	82'-11"	12'-8"

### OPTIONS AFFECTING POCKET DEPTH:

For with floating jamb add 3".

For doors with pocket cover door add 2".

For doors over 14' in height, minimum pocket depth is: 3'-2".

For other options such as multi-meeting post, rolling post or motorized doors, consult the factory.

When the motor is mounted below the header, add 22" to the stack depth.



# Won-Door DuraSound

## CURVED DOOR GUIDELINES

MANUALLY OPERATED UNDER 14'-0"

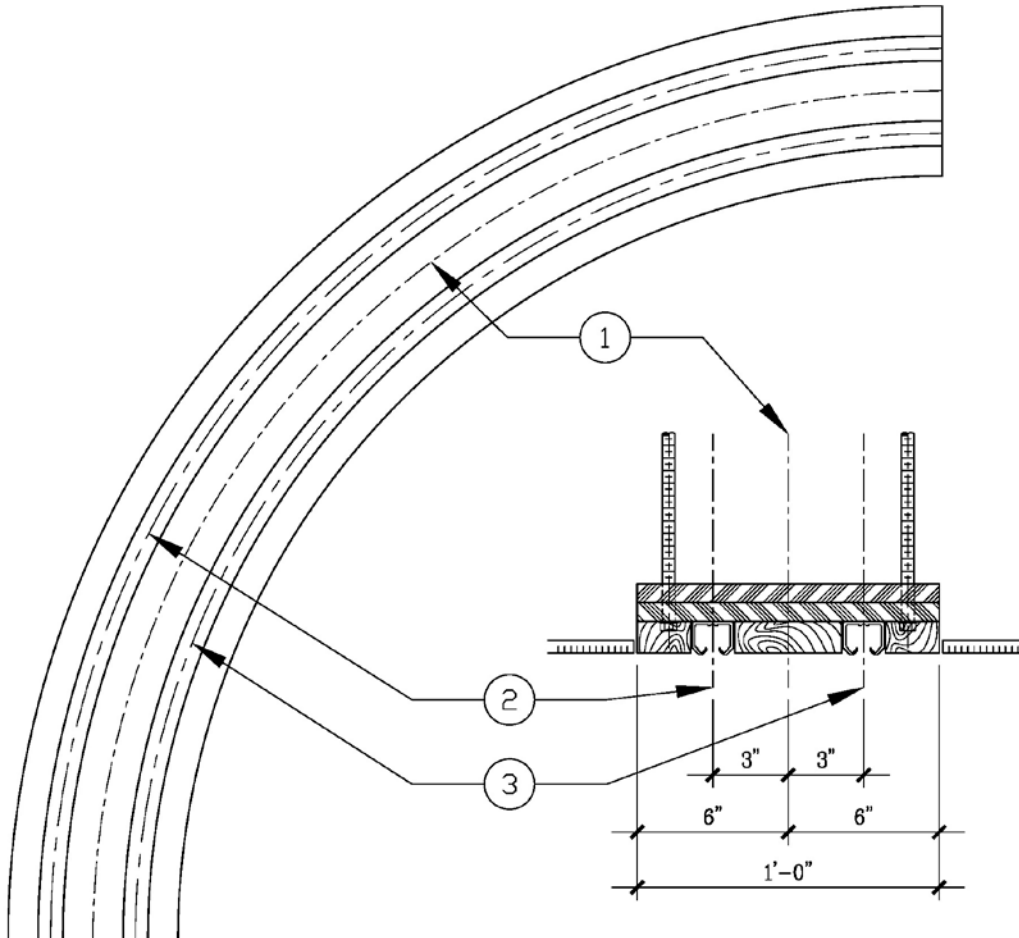

1. Centerline of header. (Radius of curved track is determined by measuring the centerline of the header).
2. Centerline of outside track.
3. Centerline of inside track.

- Minimum standard radius is 4'-0" (measured from the centerline of the header). Any custom radius greater than 4'-0" may be specified. (Minimum radius for a manually operated curved DuraSound partition is 4'-0". Minimum radius for a motorized curved DuraSound partition is 5'-0".)
- Templates of header radii are supplied to the field upon request.
- Refer to head detail for manually operated door on page 116.

Specifier's  
note





# Won-Door DuraSound

## CURVED DOOR GUIDELINES

MOTORIZED AND MANUALLY OPERATED OVER 14'-0"

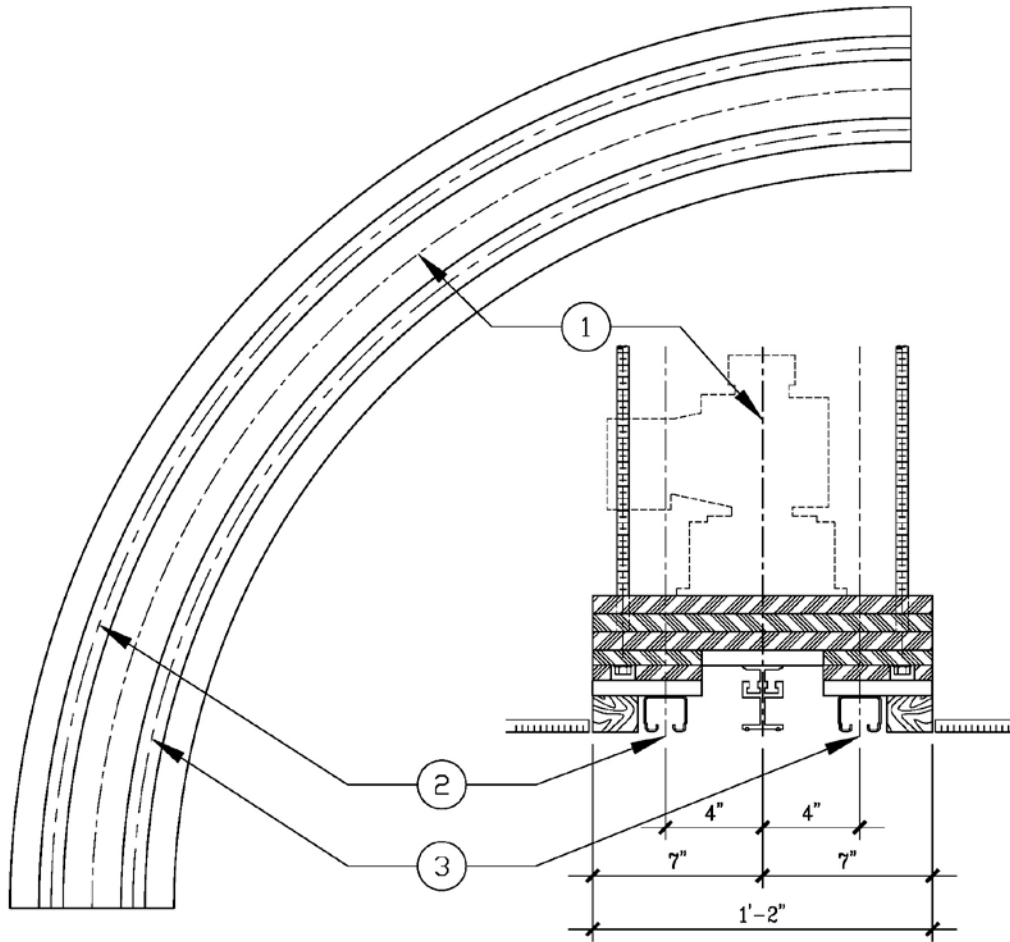

1. Centerline of header. (Radius of curved track is determined by measuring the centerline of the header).
2. Centerline of outside track.
3. Centerline of inside track.

Specifier's  
note

- Minimum standard radius is 4'-0" (measured from the centerline of the header). Any custom radius greater than 4'-0" may be specified. (Minimum radius for a manually operated curved DuraSound partition is 4'-0". Minimum radius for a motorized curved DuraSound partition is 5'-0".)
- Templates of header radii are supplied to the field upon request.
- Refer to head detail for manually operated door on page 116.



# Won-Door DuraSound

## CONFIGURATION OPTIONS MULTI-MEETING LEAD POSTS

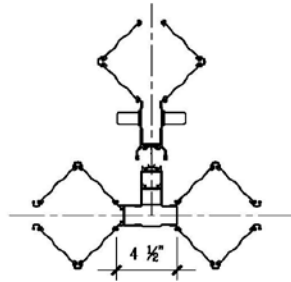

2-WAY INTERMEDIATE

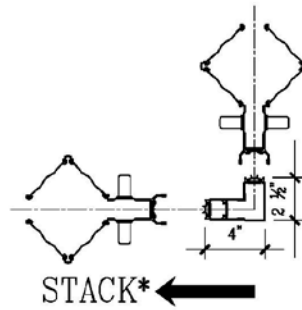

2-WAY, 90° MEETING

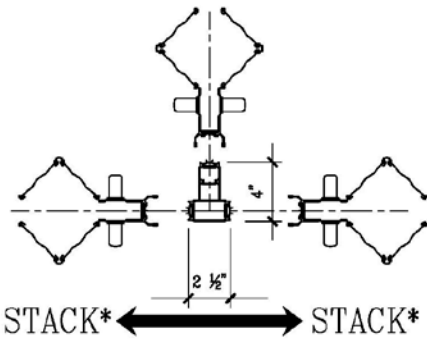

3-WAY MEETING

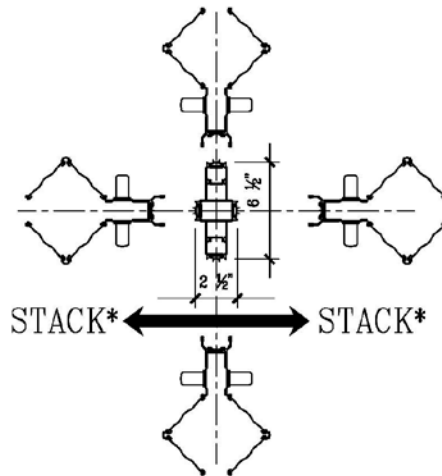

4-WAY MEETING



- \*Meeting post stacks in the direction indicated by the arrow.
- 2-way intermediate: add 4 1/2" to the stack depth.
  - 2-way 90° meeting: add 4" to the stack depth.
  - 3-way meeting: add 2 1/2" to the stack depth.
  - 4-way meeting: add 2 1/2" to the stack depth.



# Won-Door DuraSound

## MOTOR OPERATOR WIRING DIAGRAM

### TERMINAL BLOCK CONNECTIONS

- 0 GROUND
- 1 120VAC HOT
- 2 120VAC COM
- 3 KEY SWX COMMON
- 4 KEY SWX CLOSE
- 5 KEY SWX OPEN
- 8 MOTOR T1/T3
- 9 MOTOR T2/T4
- 10 MOTOR T5
- 11 MOTOR T8

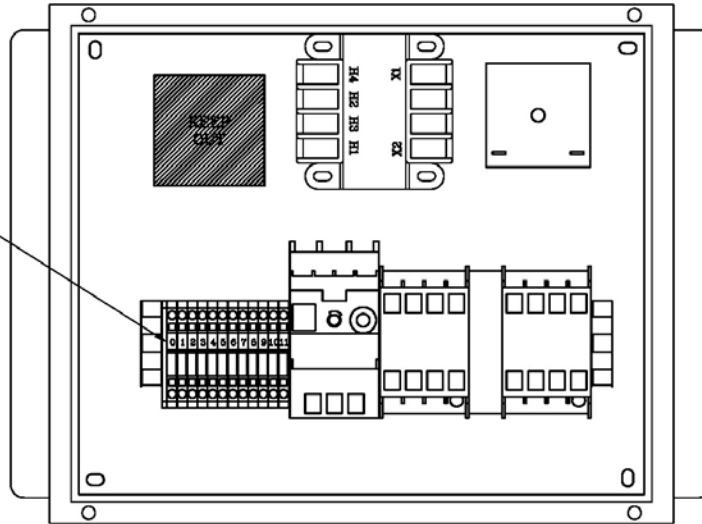

TYPICAL CONTROL SCHEMATIC

3 CONDUCTOR, 14 GA. MAX. & 18 GA. MIN.,  
24 VOLT A.C. CONDUIT & WIRE BY  
ELECTRICAL CONTRACTOR  
4" x 4" "J" BOX WITH PLASTER RING BY  
ELECTRICAL CONTRACTOR

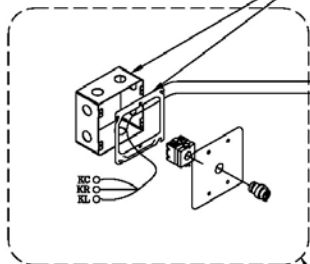

COVER PLATE & KEY SWITCH ASSEMBLY BY  
WON-DOOR (LOCATED WITHIN LINE OF  
SIGHT OF PARTITION)

120 VOLT, SINGLE PHASE W/ GROUND TO  
POWER SUPPLY BY ELECTRICAL  
CONTRACTOR

REVERSING  
MAGNETIC  
STARTER

REVERSING MAGNETIC STARTER BOX  
LOCATED ABOVE HEADER OR WITHIN SIGHT  
OF PARTITION.

4 CONDUCTOR, 14 GA. MIN., 12 GA. MAX.,  
CONDUIT & WIRING BY ELECTRICAL  
CONTRACTOR

A.C. MOTOR DRIVE UNIT

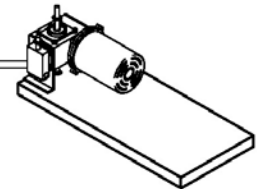

NOTE: ALL WIRING, CONDUIT, FITTINGS, ETC. MUST  
CONFORM TO NEC, JIC INDUSTRIAL CODE & APPLICABLE  
LOCAL CODES. ALL CONDUITS & CONDUCTORS BY  
ELECTRICAL CONTRACTOR UNLESS OTHERWISE NOTED.

### DURASOUND ELECTRICAL DIAGRAM

CAD FILE: DSELEC1



# Won-Door DuraSound

## OPTIONAL KEY SWITCH

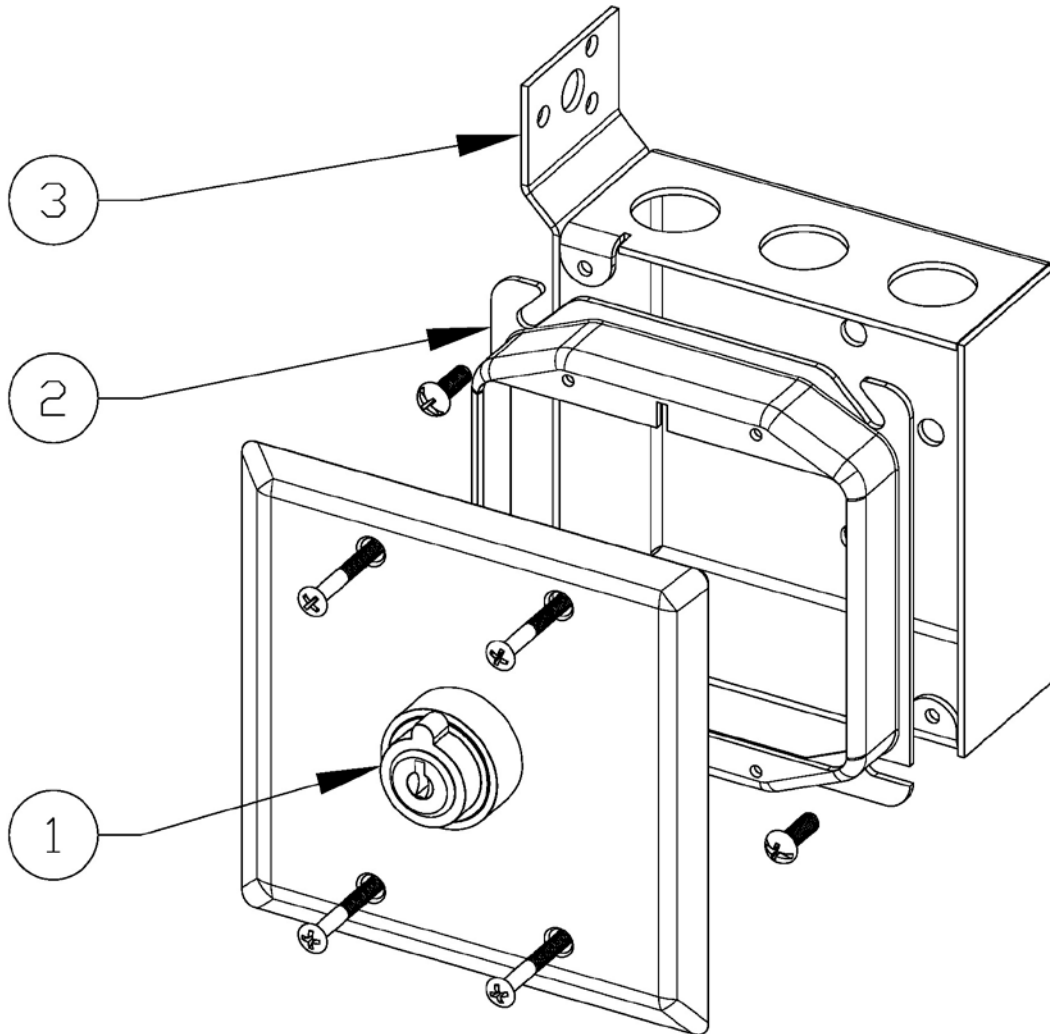

1. Key switch module.
2. Plaster ring by others.
3. 4" x 4" x 2 1/2" electrical box by others.

Specifier's  
note

One (1) key switch is provided with each motor operated partition. Additional key switches must be specified. For safety reasons, a key switch must be located within line-of-sight of the entire door opening.

# Won-Door DuraSound XL

## SECTION: 10 22 26.13 ACCORDION FOLDING PARTITIONS

### PART 1 – GENERAL

#### 1.01 SUMMARY OF WORK

- A. Division 0 and Division 1, as indexed, apply to this section.
- B. Furnish and install all accordion folding partitions shown on the drawing and specified herein.

#### 1.02 RELATED SECTIONS

- A. All headers, support structures, surrounding insulation, jambs, pocket doors, field painting, blocking and wood trim as required shall be furnished and installed by other sections.
- B. **OPTION:** If Section 2.02 K is specified, the following paragraph should be included: All electrical work including but not limited to the following electrical work by Electrical Section:
  - 1. Provide 115 volt single-phase (or 208 volt 3-phase A.C.) electrical service in conduit to the reversing magnetic starter.
  - 2. Provide 115 volt single-phase (or 208 volt 3-phase A.C. electrical service in conduit between the starter and the gear motor.
  - 3. Provide 4" x 4" electrical box for the key switch located within line-of-sight of the folding partition.
  - 4. Provide 3-conductor, 18-gauge stranded wire in conduit between the key switch and starter.
  - 5. Provide key switch for door operation (3 position switch, spring return to center from right or left).

#### 1.03 QUALITY ASSURANCE

- A. Installation shall be accomplished by factory trained personnel.
- B. Sound rated partitions shall have the laboratory sound rating indicated, when tested in accordance with the requirements of ASTM E-90.

#### 1.04 SUBMITTALS

- A. Refer to Section 01 30 00-Shop Drawings and Submittals.
- B. Indicate required stacking depth, pocket width, if applicable, and height of header above finished floor. Show installation details and layout and any optional electrical requirements.

#### 1.05 DELIVERY, STORAGE AND HANDLING

- A. Deliver to the job site in manufacturer's original, unopened package.

#### 1.06 COORDINATION BY GENERAL CONTRACTOR

- A. Coordinate the efforts of the various trades affected by the work of the section. Assure accurate installation of header, jamb, and trim. Provide "As-Built" dimensions for opening and storage pocket.
- B. Supervise unloading and handling. Store boxes flat (not more than three high) in a dry area and protect from elements that may damage materials. Replace damaged materials at no additional cost to the owner.



# Won-Door DuraSound XL

- C. **OPTION:** When Section 2.02 K is specified, the following paragraph should be included: Permanent power shall be in place for final connection when partitions are erected. Assure access to and proper clearance for motor operations.

## 1.07 WARRANTY

- A. Materials shall be warranted against defects and workmanship for a period of one (1) year from the date of substantial completion.

## PART 2 – PRODUCTS

### 2.01 MANUFACTURER

- A. Folding partitions shall be DuraSound XL as manufactured by Won-Door Corporation, Salt Lake City, Utah.

### 2.02 MATERIALS

- A. Operation: Shall be top supported and manually operated.
- B. Construction: Shall consist of two parallel, accordion-type walls of panels independently suspended with no pantographs or interconnections except at the lead-post.
- C. Panels: Shall be formed of cold rolled vinyl-clad 24-gauge V-grooved steel. Vinyl shall be permanently bonded by heat pressure lamination to the steel panels. Panels shall be connected by full height extruded vinyl hinges.
- D. Insulation: Interior surfaces of both walls shall be completely covered with a continuous blanket of two (2) pounds density foil-backed fiberglass fastened in place with steel spring-clips.
- E. Suspension systems: Shall consist of two extruded aluminum tracks spaced 12” on center attached to the overhead structural support. Each panel shall be suspended by a steel hanger pin and a pair of 1 1/2” diameter nylon-tired ball bearing rollers. Each lead-post shall be suspended by an 8-wheel ball bearing trolley.
- F. Lead-post: Shall be of 16-gauge cold rolled steel and shall be connected to the partition by specially formed steel panels. Lead-post hardware shall include standard grip-type handles and a sliding latch to affect closure.
- G. Perimeter seals: Shall consist of continuous extruded vinyl sweep strips attached to the top and bottom of the partition. Leading edges of the lead-posts and receiver posts shall be acoustically sealed by extruded vinyl interlocking seals.
- H. Hanging weight shall be 4.5 pounds per square foot.
- I. Stabilizer bar: Shall consist of a top supported internal diagonal bracing member that insures proper alignment and latching of the lead-post during operation.
- J. **OPTION:** Key Locks: Key locks shall be provided by manufacturer.
- K. **OPTION:** Motor Operator:
1. Operation: Motor-operated folding partitions shall be driven by means of a roller chain attached to the stabilizer bar trolley. An internally mounted stabilizer bar shall keep lead posts plumb and in proper alignment during operation and insure a tight fitting closure without the use of mechanical latches.



# Won-Door DuraSound XL

2. Assembly: Shall consist of a 115/230 volt single-phase A.C. motor or 208 volt 3-phase A.C. gear motor, reversing electromagnetic starter, and limit switch. Size of each motor shall be determined by manufacturer to insure proper operation.

## 2.03 ACOUSTICAL PERFORMANCE

- A. Sound transmission class (STC) shall be 48 when tested in accordance with requirements of ASTM E-90.

## 2.04 COLORS

- A. Vinyl finish color shall be selected by the architect from manufacturer's standard colors (M-885 White or ML-745 Teak).

## PART 3 – EXECUTION

### 3.01 PREPARATION BY GENERAL CONTRACTOR

- A. Openings shall be to the dimensions specified, plumb and level.
- B. Headers shall be parallel with the finished floor to within  $\pm 1/4$ " tolerance over the entire length of the opening.

### 3.02 INSPECTION

- A. Contractor shall inspect prepared opening and immediately notify the architect, in writing, of any unacceptable conditions.

### 3.03 INSTALLATION

- B. Install partitions in accordance with manufacturer's printed instructions.
- C. Upon completion of the installation, the General Contractor shall protect partitions from damage and replace or repair subsequent damage so that partitions are acceptable to the architect, at no additional charge to the owner.

Copyright © 2013 by Won-Door Corporation, all rights reserved.

END OF SECTION



# Won-Door DuraSound XL

This page intentionally left blank.





# Won-Door DuraSound XL

## STRAIGHT DOOR – HEAD DETAIL

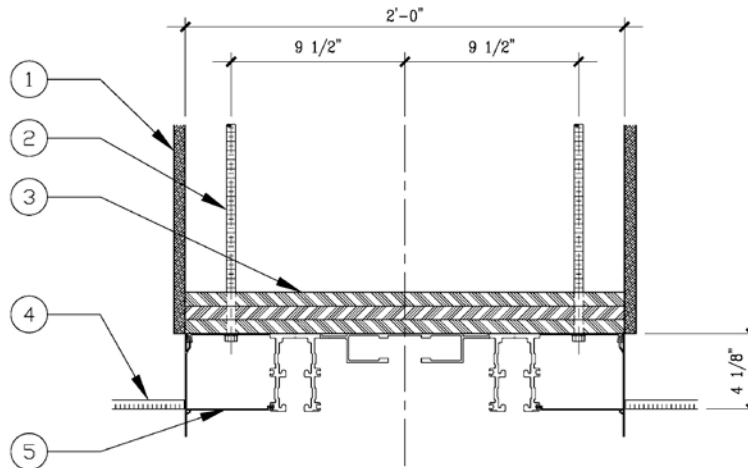

**STRAIGHT - MANUAL w/PVC SOFFIT**  
CAD FILE: XLHD1

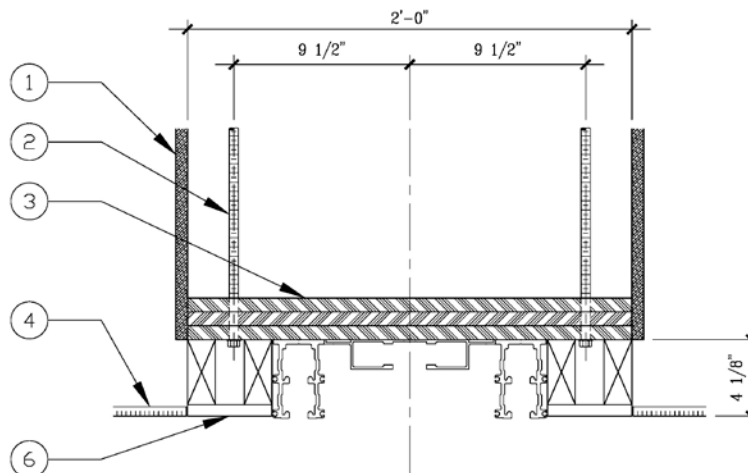

**STRAIGHT - MANUAL w/WOOD TRIM**  
CAD FILE: XLHD2

1. Insulate as required by others.
2. 1/2" threaded rods, nuts and washers by others (24" O.C. in opening, 12" O.C. in stack area).
3. Two (2) layers 3/4" x 24" x continuous plywood, to be parallel with floor with maximum tolerance of  $\pm 1/4$ " by others. (Three (3) layers required if over 14'-0" in height).
4. Ceiling by others. (Ceiling not supported by Won-Door soffit).
5. PVC Soffit by Won-Door.
6. 4 3/8" x continuous wood trim by others.



# Won-Door DuraSound XL

## STRAIGHT/CURVED – MOTORIZED DOOR HEAD DETAIL

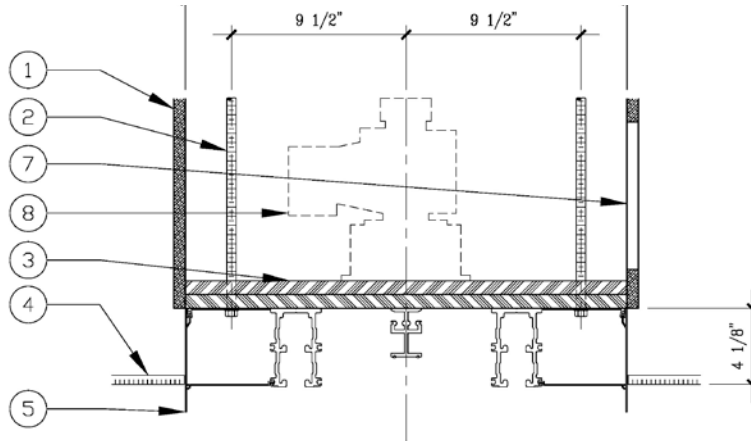

**STRAIGHT - MOTORIZED** w/PVC SOFFIT  
CAD FILE: XLHD3

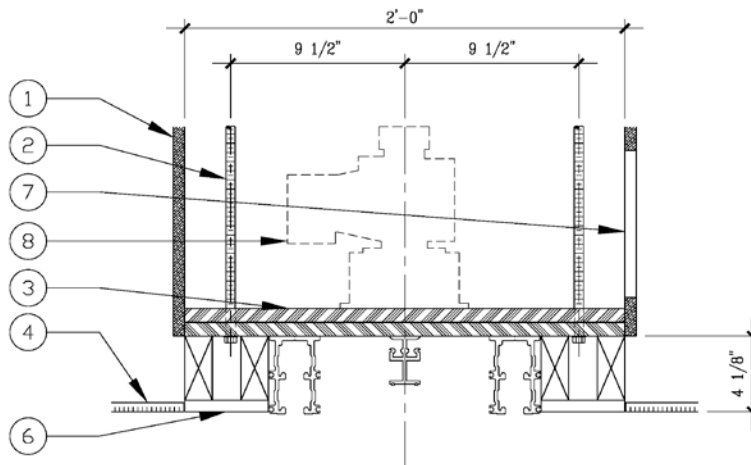

**CURVED - MOTORIZED** w/WOOD TRIM  
CAD FILE: XLHD4

1. Insulate as required by others.
2. 1/2" threaded rods, nuts and washers by others (24" O.C. in opening, 12" O.C. in stack area).
3. Three (3) layers 3/4" x 24" x continuous plywood, to be parallel with floor with maximum tolerance of  $\pm 1/4$ " by others. (Three (3) layers required if over 14'-0" in height).
4. Ceiling by others. (Ceiling not supported by Won-Door soffit).
5. PVC Soffit by Won-Door.
6. 4 3/8" x continuous wood trim by others.
7. 24" x 24" access for motor installation and service by others.
8. Motor operator assembly. (Can be mounted above or below header).

# Won-Door DuraSound XL

## PLAN VIEW

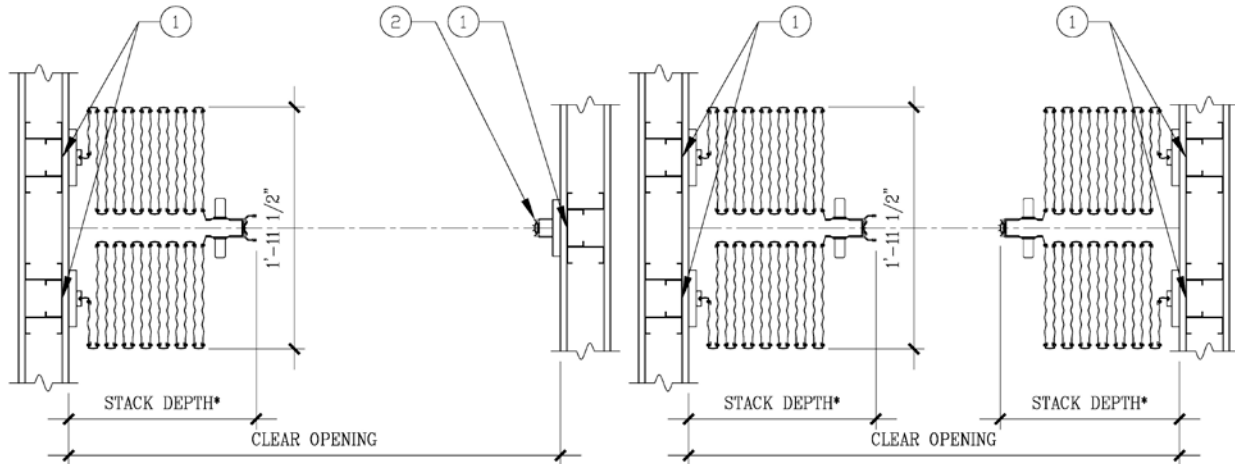

### **SINGLE PARTING w/FIXED JAMB**

\*Stack Depth= (opening in feet x .875"/ft.)+8"  
CAD FILE: XLPL1

### **BI-PARTING w/FIXED JAMB**

\*Stack Depth= (1/2 opening in feet x .875"/ft.)+8"  
CAD FILE: XLPL2

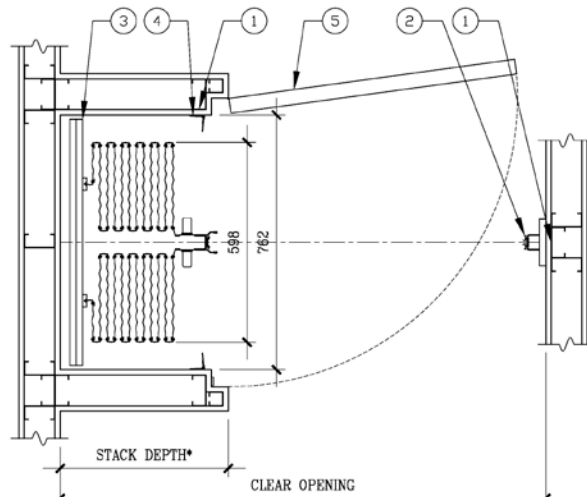

### **SINGLE PARTING w/FLOATING JAMB**

\*Stack Depth= (opening in feet x .875"/ft.)+11"+pocket door thickness  
CAD FILE: XLPL3

1. Blocking by others.
2. Aluminum striker by Won-Door.
3. Floating jamb by Won-Door.
4. Floating jamb stops by Won-Door.
5. [Optional pocket cover door by others.]



Brackets [ ] indicate specifier's option  
Minimum stack depth for a motorized DuraSound XL is 64"



# Won-Door DuraSound XL

## ELEVATION – SIDE VIEW MANUAL OPERATION

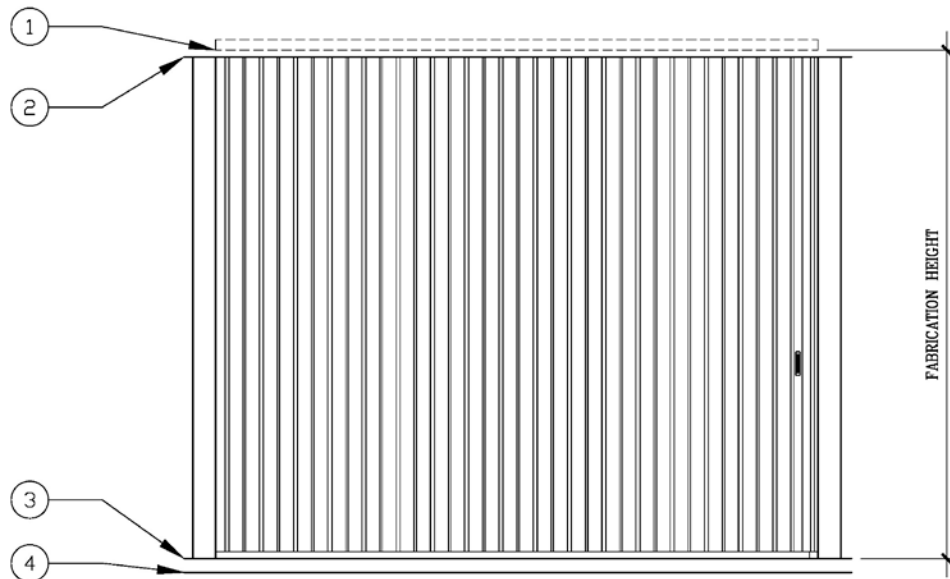

**SINGLE PARTING**  
CAD FILE: XLELEV1

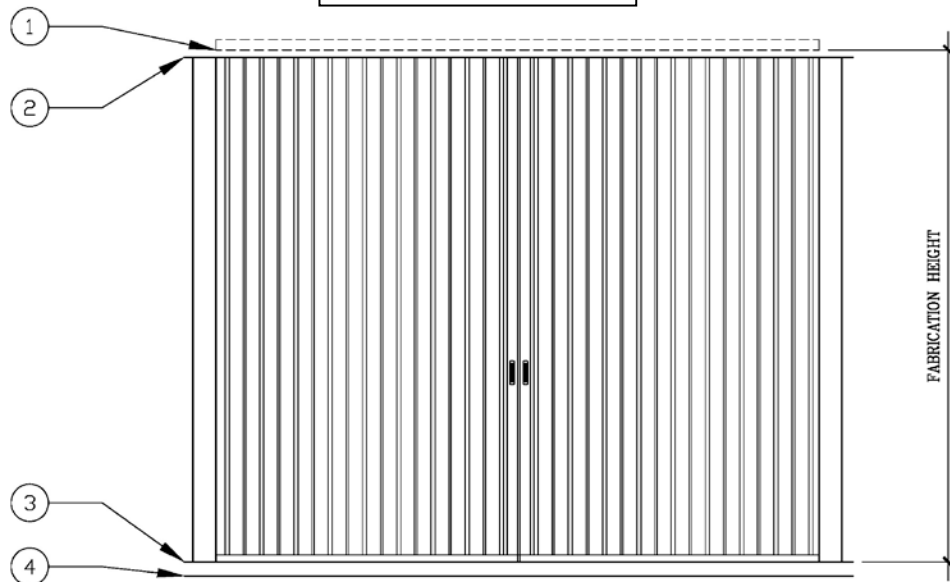

**BI-PARTING**  
CAD FILE: XLELEV2

1. Bottom of header.
2. Ceiling line.
3. Top of finished floor (carpet, tile, etc.)
4. Sub floor (concrete, etc.)



# Won-Door DuraSound XL

## ELEVATION – SIDE VIEW MOTORIZED OPERATION

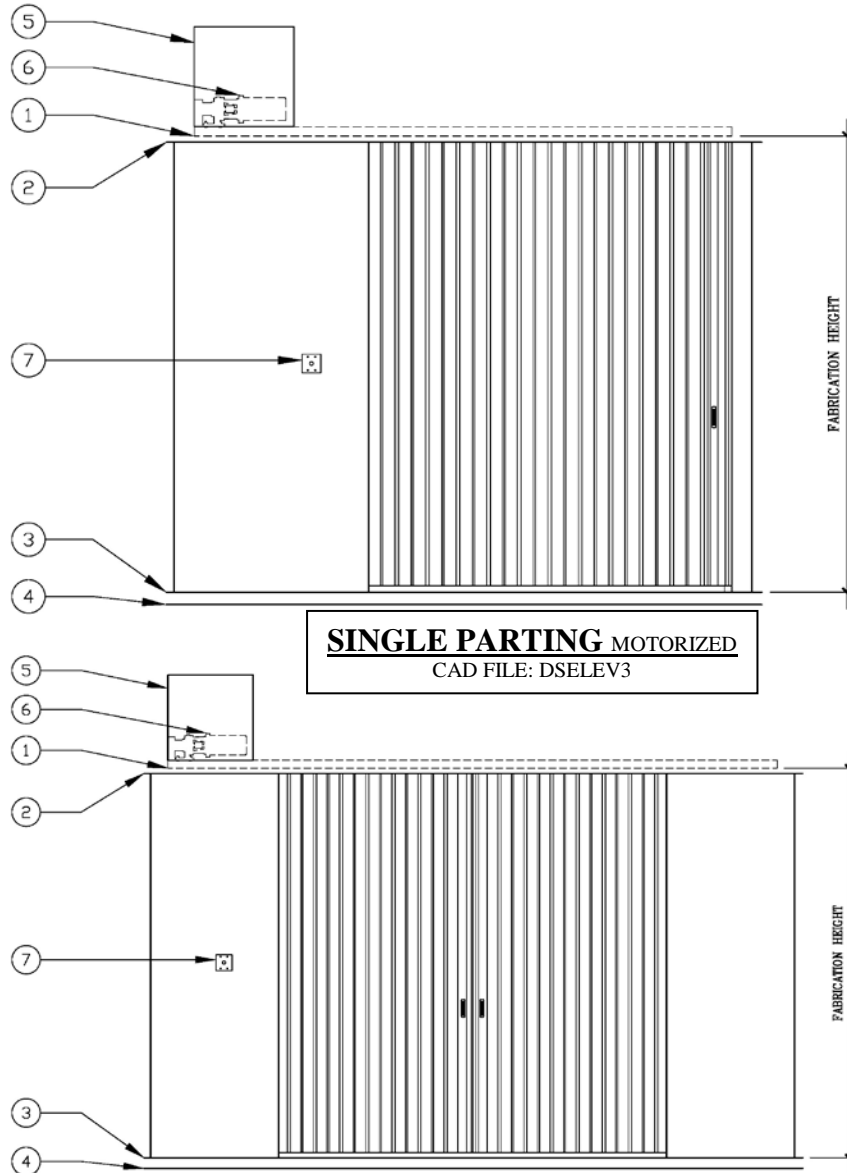

1. Bottom of header.
2. Ceiling line.
3. Top of finished floor (carpet, tile, etc.)
4. Sub floor (concrete, etc.)
5. AC motor operator by Won-Door. (Motor may be located above or below header).
6. 24" x 24" access by others.
7. Key switch by Won-Door. (Must be located within line-of-sight of the entire door opening). (See page 142.)

Specifier's  
note

For motorized bi-parting doors, a motor operator is located at one end only. For motorized unequal bi-parting doors, motor operators and access are required at both ends.



# Won-Door DuraSound XL

## ELEVATION – FRONT VIEW

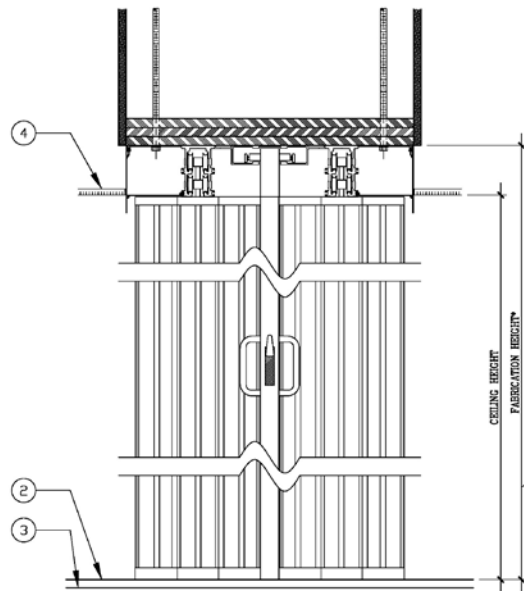

**T-08 STRAIGHT TRACK** w/PVC SOFFIT  
CAD FILE: XLELEV5

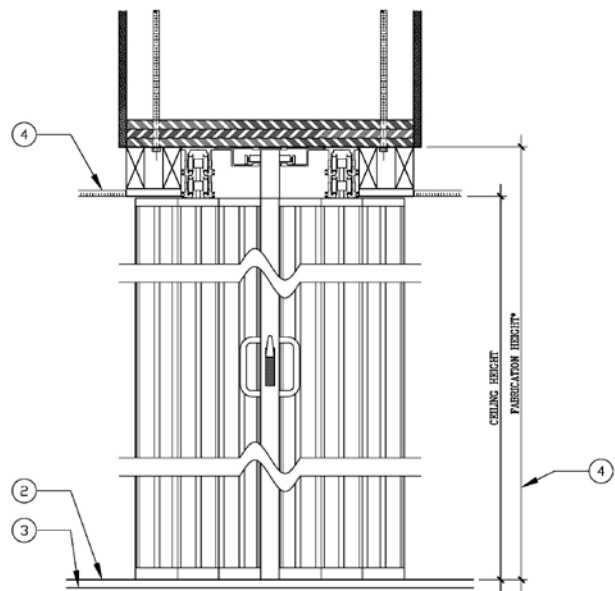

**T-08 CURVED TRACK** w/WOOD TRIM  
CAD FILE: XLELEV6

1. Ceiling by others (not supported by PVC soffit)
2. Top of finished floor (carpet, tile, etc.)
3. Sub floor (concrete, etc.)
4. Fabrication height. \*Field dimension taken from top of track to top of finished floor.

### Door Profile Widths:

- Motorized Operated Doors:
  - Stacked width: 23 3/4"
  - Extended width: 14"
- Manually Operated Doors:
  - Stacked width: 13 3/4"
  - Extended width: 11 1/2"

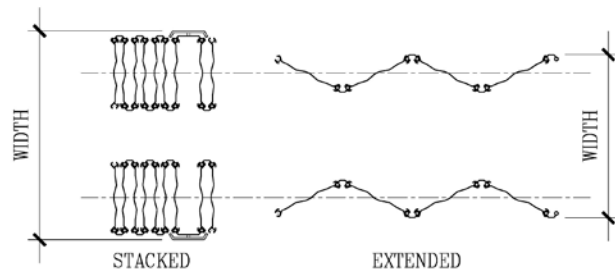

# Won-Door DuraSound XL

## DURASOUND XL – POCKET DEPTH CALCULATION CHART MANUALLY OPERATED

Clear Opening Width		Pocket Depth
From:	To:	
3'-0"	12'-7"	1'-6"
12'-8"	13'-11"	1'-7"
14'-0"	15'-3"	1'-8"
15'-4"	16'-7"	1'-9"
16'-8"	17'-11"	1'-10"
18'-0"	19'-3"	1'-11"
19'-4"	20'-7"	2'-1"
20'-8"	21'-11"	2'-2"
22'-0"	23'-3"	2'-3"
23'-4"	24'-7"	2'-4"
24'-8"	25'-11"	2'-5"
26'-0"	27'-3"	2'-6"
27'-4"	28'-7"	2'-8"
28'-8"	29'-11"	2'-9"
30'-0"	31'-3"	2'-10"
31'-4"	32'-7"	2'-11"
32'-8"	33'-11"	3'-0"
34'-0"	35'-3"	3'-1"
35'-4"	36'-7"	3'-3"
36'-8"	37'-11"	3'-4"
38'-0"	39'-3"	3'-5"
39'-4"	40'-7"	3'-6"
40'-8"	41'-11"	3'-7"
42'-0"	43'-3"	3'-8"
43'-4"	44'-7"	3'-10"
44'-8"	45'-11"	3'-11"
46'-0"	47'-3"	4'-0"
47'-4"	48'-7"	4'-1"
48'-8"	49'-11"	4'-2"
50'-0"	51'-3"	4'-3"
51'-4"	52'-7"	4'-5"
52'-8"	53'-11"	4'-6"
54'-0"	55'-3"	4'-7"
55'-4"	56'-7"	4'-8"
56'-8"	57'-11"	4'-9"
58'-0"	59'-3"	4'-10"
59'-4"	60'-7"	5'-0"
60'-8"	61'-11"	5'-1"
62'-0"	63'-3"	5'-2"
63'-4"	64'-7"	5'-3"
64'-8"	65'-11"	5'-4"
66'-0"	67'-3"	5'-5"

\*For bi-parting doors: Use 1/2 the clear opening width.

Clear Opening Width		Pocket Depth
From:	To:	
67'-4"	68'-7"	5'-7"
68'-8"	69'-11"	5'-8"
70'-0"	71'-3"	5'-9"
71'-4"	72'-7"	5'-10"
72'-8"	73'-11"	5'-11"
74'-0"	75'-3"	6'-0"
75'-4"	76'-7"	6'-2"
76'-8"	77'-11"	6'-3"
78'-0"	79'-3"	6'-4"
79'-4"	80'-7"	6'-5"
80'-8"	81'-11"	6'-6"
82'-0"	83'-3"	6'-7"
83'-4"	84'-7"	6'-9"
84'-8"	85'-11"	6'-10"
86'-0"	87'-3"	6'-11"
87'-4"	88'-7"	7'-0"
88'-8"	89'-11"	7'-1"
90'-0"	91'-3"	7'-2"
91'-4"	92'-7"	7'-4"
92'-8"	93'-11"	7'-5"
94'-0"	95'-3"	7'-6"
95'-4"	96'-7"	7'-7"
96'-8"	97'-11"	7'-8"
98'-0"	99'-3"	7'-9"
99'-4"	100'-7"	7'-11"
100'-8"	101'-11"	8'-0"
102'-0"	103'-3"	8'-1"
103'-4"	104'-7"	8'-2"
104'-8"	105'-11"	8'-3"
106'-0"	107'-3"	8'-4"
107'-4"	108'-7"	8'-6"
108'-8"	109'-11"	8'-7"
110'-0"	111'-3"	8'-8"
111'-4"	112'-7"	8'-9"
112'-8"	113'-11"	8'-10"
114'-0"	115'-3"	8'-11"
115'-4"	116'-7"	9'-1"
116'-8"	117'-11"	9'-2"
118'-0"	119'-3"	9'-3"
119'-4"	120'-7"	9'-4"
120'-8"	121'-11"	9'-5"
122'-0"	123'-3"	9'-6"

### OPTIONS AFFECTING POCKET DEPTH:

For with floating jamb add 3".

For doors with pocket cover door add 2".

For doors over 14' in height, minimum pocket depth is: 3'-2".

For other options such as multi-meeting post, rolling post or motorized doors, consult the factory.



# Won-Door DuraSound XL

## DURASOUND XL – POCKET DEPTH CALCULATION CHART MOTOR OPERATED

\*For bi-parting doors: Use 1/2 the clear opening width.

Clear Opening Width		Pocket Depth
From:	To:	
3'-0"	54'-10"	4'-6"
54'-11"	56'-2"	4'-8"
56'-3"	57'-6"	4'-9"
57'-7"	58'-10"	4'-10"
58'-11"	60'-2"	4'-11"
60'-3"	61'-6"	5'-0"
61'-7"	62'-10"	5'-1"
62'-11"	64'-2"	5'-3"
64'-3"	65'-6"	5'-4"
65'-7"	66'-10"	5'-5"
66'-11"	68'-2"	5'-6"
68'-3"	69'-6"	5'-7"
69'-7"	70'-10"	5'-8"
70'-11"	72'-2"	5'-10"
72'-3"	73'-6"	5'-11"
73'-7"	74'-10"	6'-0"
74'-11"	76'-2"	6'-1"
76'-3"	77'-6"	6'-2"
77'-7"	78'-10"	6'-3"
78'-11"	80'-2"	6'-5"
80'-3"	81'-6"	6'-6"
81'-7"	82'-10"	6'-7"
82'-11"	84'-2"	6'-8"
84'-3"	85'-6"	6'-9"
85'-7"	86'-10"	6'-10"
86'-11"	88'-2"	7'-0"
88'-3"	89'-6"	7'-1"
89'-7"	90'-10"	7'-2"
90'-11"	92'-2"	7'-3"
92'-3"	93'-6"	7'-4"
93'-7"	94'-10"	7'-5"
94'-11"	96'-2"	7'-7"
96'-3"	97'-6"	7'-8"
97'-7"	98'-10"	7'-9"
98'-11"	100'-2"	7'-10"
100'-3"	101'-6"	7'-11"
101'-7"	102'-10"	8'-0"
102'-11"	104'-2"	8'-2"
104'-3"	105'-6"	8'-3"
105'-7"	106'-10"	8'-4"
106'-11"	108'-2"	8'-5"
108'-3"	109'-6"	8'-6"

Clear Opening Width		Pocket Depth
From:	To:	
109'-7"	110'-10"	8'-7"
110'-11"	112'-2"	8'-9"
112'-3"	113'-6"	8'-10"
113'-7"	114'-10"	8'-11"
114'-11"	116'-2"	9'-0"
116'-3"	117'-6"	9'-1"
117'-7"	118'-10"	9'-2"
118'-11"	120'-2"	9'-4"
120'-3"	121'-6"	9'-5"
121'-7"	122'-10"	9'-6"
122'-11"	124'-2"	9'-7"
124'-3"	125'-6"	9'-8"
125'-7"	126'-10"	9'-9"
126'-11"	128'-2"	9'-11"
128'-3"	129'-6"	10'-0"
129'-7"	130'-10"	10'-1"
130'-11"	132'-2"	10'-2"
132'-3"	133'-6"	10'-3"
133'-7"	134'-10"	10'-4"
134'-11"	136'-2"	10'-6"
136'-3"	137'-6"	10'-7"
137'-7"	138'-10"	10'-8"
138'-11"	140'-2"	10'-9"
140'-3"	141'-6"	10'-10"
141'-7"	142'-10"	10'-11"
142'-11"	144'-2"	11'-1"
144'-3"	145'-6"	11'-2"
145'-7"	146'-10"	11'-3"
146'-11"	148'-2"	11'-4"
148'-3"	149'-6"	11'-5"
149'-7"	150'-10"	11'-6"
150'-11"	152'-2"	11'-8"
152'-3"	153'-6"	11'-9"
153'-7"	154'-10"	11'-10"
154'-11"	156'-2"	11'-11"
156'-3"	157'-6"	12'-0"
157'-7"	158'-10"	12'-1"
158'-11"	160'-2"	12'-3"
160'-3"	161'-6"	12'-4"
161'-7"	162'-10"	12'-5"
162'-11"	164'-2"	12'-6"
164'-3"	165'-6"	12'-7"

### OPTIONS AFFECTING POCKET DEPTH:

For with floating jamb add 3".

For doors with pocket cover door ad 2".

For doors over 14' in height, minimum pocket depth is: 3'-2".

For other options such as multi-meeting post, rolling post or motorized doors, consult the factory.

When the motor is mounted below the header, add 22" to the stack depth.





# Won-Door DuraSound XL

## MOTOR OPERATOR WIRING DIAGRAM

### TERMINAL BLOCK CONNECTIONS

- 0 GROUND
- 1 120VAC HOT
- 2 120VAC COM
- 3 KEY SWX COMMON
- 4 KEY SWX CLOSE
- 5 KEY SWX OPEN
- 8 MOTOR T1/T3
- 9 MOTOR T2/T4
- 10 MOTOR T5
- 11 MOTOR T8

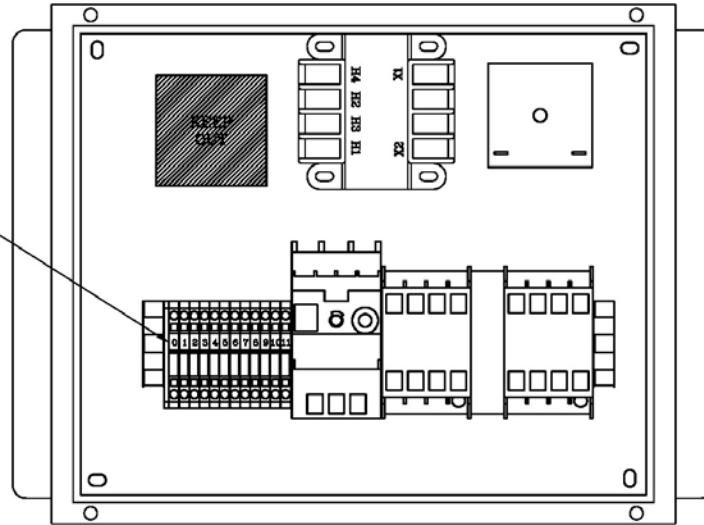

TYPICAL CONTROL SCHEMATIC

3 CONDUCTOR, 14 GA. MAX. & 18 GA. MIN.,  
24 VOLT A.C. CONDUIT & WIRE BY  
ELECTRICAL CONTRACTOR  
4" x 4" "J" BOX WITH PLASTER RING BY  
ELECTRICAL CONTRACTOR

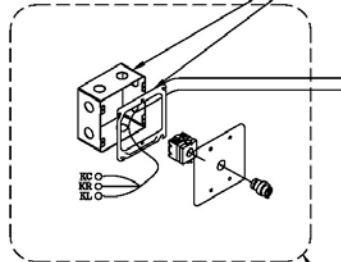

COVER PLATE & KEY SWITCH ASSEMBLY BY  
WON-DOOR (LOCATED WITHIN LINE OF  
SIGHT OF PARTITION)

120 VOLT, SINGLE PHASE W/ GROUND TO  
POWER SUPPLY BY ELECTRICAL  
CONTRACTOR

REVERSING  
MAGNETIC  
STARTER

REVERSING MAGNETIC STARTER BOX  
LOCATED ABOVE HEADER OR WITHIN SIGHT  
OF PARTITION.

4 CONDUCTOR, 14 GA. MIN., 12 GA. MAX.,  
CONDUIT & WIRING BY ELECTRICAL  
CONTRACTOR

A.C. MOTOR DRIVE UNIT

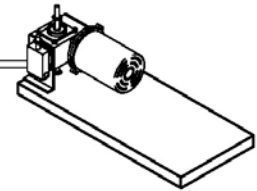

NOTE: ALL WIRING, CONDUIT, FITTINGS, ETC. MUST  
CONFORM TO NEC, JIC INDUSTRIAL CODE & APPLICABLE  
LOCAL CODES. ALL CONDUITS & CONDUCTORS BY  
ELECTRICAL CONTRACTOR UNLESS OTHERWISE NOTED.

### DURASOUND XL ELECTRICAL DIAGRAM

CAD FILE: DSELEC1



# Won-Door DuraSound XL

## OPTIONAL KEY SWITCH

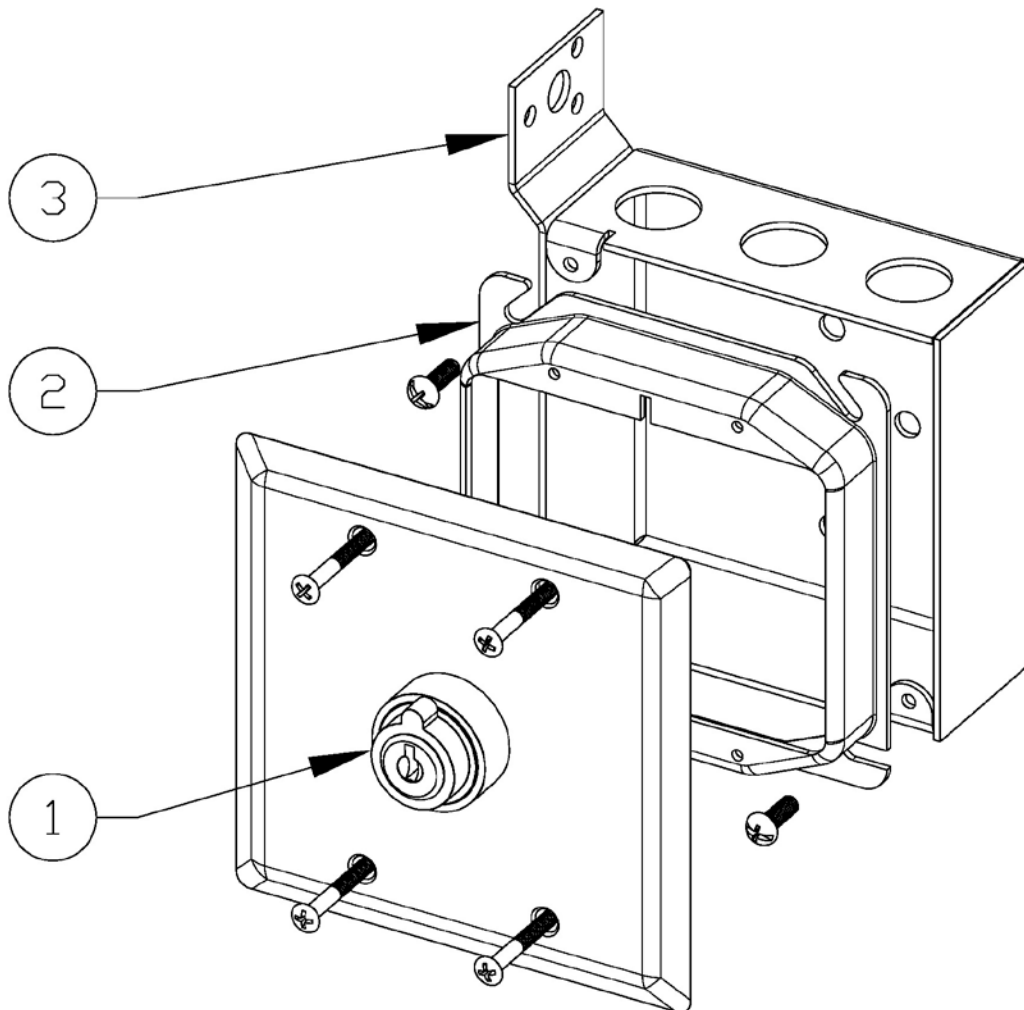

1. Key switch module.
2. Plaster ring by others.
3. 4" x 4" x 2 1/2" electrical box by others.



One (1) key switch is provided with each motor operated partition. Additional key switches must be specified. For safety reasons, a key switch must be located within line-of-sight of the entire door opening.