



BLAST FOUNDATIONS

PASSAGES



Name: _____





Really Great Reading

P.O. Box 46
Cabin John, MD 20818
866-401-7323

www.ReallyGreatReading.com

Copyright © 2018 Really Great Reading®

Curriculum Development Team:
Janeen Hergert, M.Ed., Sarah Zelenak, Amy E. Vanden Boogart, Ed.D.,
Kathryn A Sevier, M.Ed, Julie Sealine, M.S.

Graphic Design/Illustration:
Ingrid Shwaiko

No portion of this book may be reproduced or transmitted in any form or by any means, electronic or mechanical, including photocopying or recording or by any information storage or retrieval system, without the express written permission of the publisher.

Printed in the U.S.A.

INTRODUCTION

OVERVIEW

Blast Foundations is a series of lessons focused on the essential foundational skills that students should master in their early reading education. It includes explicit instruction and progress monitoring of letter-sound correspondences, phonemic and phonological awareness, high-frequency word fluency, phonics knowledge, and spelling. The lessons are designed to teach these essential skills, which promote strong decoding and fluent, accurate reading.

Blast Foundations lessons are designed for young emerging or older struggling readers. *Blast* is most commonly taught in Kindergarten, 1st, and 2nd grade to students who are working to master beginning reading skills appropriate for their age and grade level. For students in 3rd grade and beyond, *Blast* is typically reserved for the most severely struggling readers who have not yet learned the skills they should have mastered in Kindergarten through 2nd grade.

The *Blast Passages* are strictly controlled stories that align with the phonics skills and Heart Words taught in *Blast Foundations*. Aside from the Heart Words in the passages, all of the words included are decodable; however, due to the use of some Heart Words that have not been explicitly taught in *Blast Foundations* according to the guidelines described below, we consider the passages to be “strictly controlled” rather than completely “decodable.”

There are 22 passages, most of which are fiction: one for each unit in *Blast*, beginning with Unit 4. The passages provide students with longer, connected-text opportunities to apply the skills they are learning in *Blast Foundations*. In both sets of *Blast* workbooks, the *Primary Student Workbook* and the *Elementary Student Workbook*, students practice reading words, phrases, and sentences. With the *Blast Passages*, students extend their practice to longer sections of text. As students develop mastery and automaticity with the skills taught in *Blast*, the *Blast Passages* can be used to reinforce these skills, to provide opportunities for practice, and, ideally, to build fluency. Students will also gain confidence as readers. Reading text controlled for the specific skills students have already learned allows them to read with success, leading to confidence and the willingness to tackle more difficult text in the future.

FEATURES

Controlled and Cumulative

The *Blast Passages* are strictly controlled. The passages consist of words containing phonics skills students have explicitly learned in *Blast Foundations*, Heart Words taught in *Blast Foundations*, and other select words from the Dolch 220 high-frequency word list.

Each passage emphasizes the phonics skill(s) students learned in the corresponding unit of *Blast Foundations*. Other words that are not high-frequency words are decodable according to the phonics skills students learned in

QUICK FACTS

WHAT?

22 strictly controlled passages, one for each unit in our *Blast Foundations Teacher Guides*, beginning with Unit 4.

WHEN?

After Lesson 4 of each corresponding *Blast* unit has been taught.

WHERE?

Can be used in the classroom, in small groups, or sent home for practice.

For more information, see pp. 29–33 in this document, or visit reallygreatreading.com/blast-foundations



previous units. If a student struggles with a decodable word while reading through a passage, remind him or her to use the strategies learned in the *Blast* phonics lessons to read the word.

The high-frequency words used in the passages fall into one of three categories: 1) Heart Words that students have been explicitly taught in the current and previous *Blast Foundations* units; 2) up to 5 additional words per passage, not explicitly taught in *Blast*, from the Dolch 220 first through third grade lists (these are included in a “Words to Preview” section in the standard and differentiated versions of the passages since they may be unfamiliar to students); 3) additional words, not explicitly taught in *Blast*, from the Dolch 220 pre-primer and primer lists. In the differentiated version of each passage, the additional Dolch 220 pre-primer and primer words are limited to five or fewer. See below for more information on the Words to Preview and on the differentiated passages.

Words to Preview

As mentioned above, up to four words from the Dolch 220 list that are from the first through third grade word lists and have not been explicitly taught in the *Blast* lessons appear in a “Words to Preview” section at the top of each passage. In the passages, these words will be underlined. The teacher should review these words with the students several times before reading the passage. Since students are not expected to know these words (as they are above grade level for most *Blast Foundations* students), the teacher may read these words to the students when they are encountered in the passage if necessary. Optionally, the teacher may consider devoting some instructional time to teaching words that frequently appear in the passages. See Words to Preview A in the chart on pages vii-ix for a list of these words for each passage.

Heart Words

Heart Words the students have already learned in *Blast Foundations* are not marked in the standard versions of the passages. If a student struggles with a Heart Word, remind him or her this is a Heart Word he or she has learned and, if necessary, encourage the student to look at, think about, and say (Look, Think, Say) the word, or provide the word for the student.

Increasing Length

The *Blast Passages* increase in length as the units increase, ranging from half a page to a full page of text. The passages contain only single-syllable words (including only single-syllable Heart Words) until Unit 14 when students are introduced to two-syllable words. The complexity of the passages and the level of vocabulary also increase as students progress.

Comprehension Questions

You can use the comprehension questions on page 23 to help students practice extracting meaning from the passages. There are three literal questions and one inferential question for each passage.

USING THE BLAST PASSAGES

The *Blast Passages* can be used in the classroom, in small groups, or sent home for practice. Students can begin practicing with a passage after Lesson 4 of the corresponding



unit in *Blast Foundations* has been taught. Students should practice with words, phrases, and sentences in the Lesson 4 student workbook activities for their current unit before moving on to read the passage. The passages can be read as part of the *Blast* lesson or at another time, such as at the beginning of guided reading groups or at a teacher-led center.

Before asking students to read the passage, review the words in the “Words to Preview” section several times. (If you are using the differentiated version of the passage, there will be two sections of words to review.) You should read and pronounce these words for your students and provide definitions or example sentences to clarify the meaning of any unfamiliar words. Students should then practice reading the passages aloud, focusing on reading each word accurately.

Additional Activities

Once students have read through a passage with you, incorporate other opportunities to practice with the text throughout the next several days. Some ideas for additional practice include:

- Underlining a new phonics concept in words, such as *digraph th* or 2-sound blends
- Highlighting words containing a certain feature, such as *short a* or Open Syllables
- Drawing a line to separate the syllables of 2-syllable words
- Circling the Heart Words
- Reading to a partner
- Reading silently
- Reading to someone at home
- Using the comprehension questions on page 23 to help students practice extracting meaning from the passages

Building Fluency

To use the *Blast Passages* to help build fluency, students should reread the passages multiple times over the course of several days. It is important to note that students should be reading accurately before they begin working on reading faster. A quick, informal way to check for accuracy is to have the student read the passage aloud to you. If the student can read the passage with three or fewer errors, he or she can use that passage to work on building his or her reading rate. A more precise way to check for accuracy is to calculate a student’s accuracy percentage with the passage. Have the student read the passage aloud and keep track of the number of errors that are made. To find the number of words correct, subtract the number of errors from the total number of words in the passage, which can be found at the top of each passage in the gray polygon. Divide the number of words correct by the total number of words in the passage (this information is in the top corner of each passage); then, multiply by 100 to get the accuracy percentage. Many teachers consider 95% accuracy to be a good goal to have students meet before beginning to work on increasing reading rate.

To begin working on fluency, ask the students to read the passage out loud; then model fluent reading by reading the passage aloud to them. After modeling what it sounds like when the passage is read fluently, ask the students to read the passage aloud again, trying to make their reading sound like yours. This procedure can be repeated on several



occasions. Students can get additional practice building fluency by reading the passages to partners in class or taking the passages home to read aloud to a sibling, parent, or other caretaker or adult.

DIFFERENTIATED PASSAGES

Each *Blast Passage* has differentiated versions that can be found in *Blast Online's Supplemental Resources*. You'll find an example differentiated passage on page 29 of this packet. The differentiated versions can be used for students needing additional support to read the passages accurately and/or fluently. Once a student has been successful reading the differentiated passage, he or she should move on to the standard passage.

Words with Target Phonics Concepts in the Differentiated Passages

Teachers can use the differentiated passages with students needing additional support with phonics concepts such as digraphs and two-syllable words as well. The differentiated passages direct teachers to work with students to identify and mark words containing the target phonics concept for that unit. For example, students may underline *digraph sh* or draw a line between the syllables in two-syllable words. Words in the passage containing the target phonics concept are listed in a column on the right side of the passage. In small groups, the teacher can guide students to preview the text as they identify words containing the target feature and mark them. The students should decode these words individually and then read the passage. A list of the target phonics concepts students can mark for each unit can be found in the Words to Preview and Differentiation Suggestions table on pages vii-ix.

Heart Words and Dolch Words in the Differentiated Passages

The differentiated version is for students struggling to read the words accurately. These differentiated passages may vary slightly from the standard version so that students encounter fewer high-frequency words and a higher percentage of decodable words. There are only up to five pre-primer and primer Dolch words (not including **l** and **a**) included that have not been explicitly taught in *Blast*. These words will appear in list B of the “Words to Preview” section at the top of the passage. The teacher can quickly review these words with the students before focusing on the less familiar 1st, 2nd, or 3rd grade Dolch words in “Words to Preview” list A. All the words in the “Words to Preview” section are underlined in the passage. In addition, Heart Words that have been taught in the *Blast* lessons have small hearts above them. Beginning in Unit 15, the words **a**, **an**, **and**, **the**, **l**, and **to** are no longer marked since students should be very familiar with these words.

Utilizing Differentiated Passages for Fluency Practice

Phrase scooping is a useful scaffold for helping students to read more fluently. It involves using a pen or pencil to draw a “scoop” or a curved line underneath groups of words, essentially “chunking” the sentence into phrases. You may guide students in scooping phrases within the sentences of the passage on the standard passage or on the differentiated passage for Heart Words and Dolch words. It may be helpful to review the passage once with the student, helping him or her to scoop the phrases. Then, the student can read the passage independently, using the scooped phrases to guide them



to fluency. Generally, phrases of two to five words allow for fluent reading without losing comprehension. Phrases often begin with prepositions (to, for, with, like...), conjunctions (and, but, so, or...), or adverbs (when, how, why...) as in “We take a cab – to the ship – and get on,” or “I don’t know – how to bake a cake.”

Pre-Primer and Primer Dolch Words

These words are included in the passages but not placed in the “Words to Preview” section of the standard version because most typically developing readers should be familiar with these words before first grade. (Note that these words are included in list B of the “Words to Preview” section in all of the differentiated versions of the passages, as described above. This enables students who are not familiar with the words to practice with them briefly before reading the passage.) A list of the pre-primer and primer Dolch words included in each passage can be found on in Words to Preview B in the table on pages vii-ix.

Additional Differentiated Passages for Units 4-6

An additional differentiated version is available for the Unit 4-6 passages. Passages 4-6 have been modified to strictly control the consonants that are used in decodable words according to the sequence of consonants students are expected to have mastered in *Blast*. In contrast, the standard passages for Units 4-6 are controlled for vowels and other phonics concepts such as digraphs, but all single consonants are used. The standard passages can be read by students who have a firm grasp of consonant spellings. The differentiated passages can be used by students who are only comfortable with the consonants that have been explicitly introduced in the *Blast* sequence.

Available Versions of the Blast Passages

- Units 4-6
 1. Standard passage
 2. Differentiated passage for Heart Words, Dolch words, and phonics features
 3. Differentiated passage for strictly controlled consonants
- Units 7-25
 1. Standard passage
 2. Differentiated passage for Heart Words, Dolch words, and phonics features

Words to Preview and Differentiation Suggestions for Differentiated Passages

BLAST PASSAGE	WORDS TO PREVIEW <i>List A is 1st-3rd Grade Dolch Words. List B is pre-primer and primer Dolch words.</i>	DIFFERENTIATION SUGGESTIONS <i>Have the students find and mark these skills before reading the passage.</i>
Unit 4: On the Ship	A: take, give B: we, get, new, find, go, eat	Underline digraph sh – Students should underline the s and h together since the letters work together to spell one sound.
Unit 5: The Rush to Camp	A: could, fall, when, gave B: get, no, so, said, go	Underline words with <i>short u</i> .



BLAST PASSAGE	WORDS TO PREVIEW <i>List A is 1st-3rd Grade Dolch Words. List B is pre-primer and primer Dolch words.</i>	DIFFERENTIATION SUGGESTIONS <i>Have the students find and mark these skills before reading the passage.</i>
Unit 6: A New Dog	A: walk, give, best, kind B: saw, be, have, too, get	Underline <i>digraph th</i> – Students should underline both letters together since they work together to spell one sound.
Unit 7: Hens and Pigs	A: live B: go, out, like, eat, are	Underline words with <i>short e</i> .
Unit 8: The Chimp	A: <i>none</i> B: too, eat, say, go, find	Underline <i>digraphs ch</i> and <i>wh</i> – Students should underline both letters together since they work together to spell one sound.
Unit 9: Tick Tock	A: take, give, put, bring B: so, out, go, now, down	Underline <i>digraph ck</i> – Students should underline both letters together since they work together to spell one sound.
Unit 10: Fudge	A: made, put, would, give B: good, my, so, me, new	Underline <i>trigraphs tch</i> and <i>dge</i> – Students should underline all three letters together since they work together to spell one sound.
Unit 11: The Fall	A: gave, her, pull B: play, my, me, want, saw	Underline <i>chunk all</i> and/or words that follow the Double Trouble Rule.
Unit 12: A Ball	A: may, round, try B: too, two, play, good	Underline <i>digraph ck</i> , <i>trigraphs tch</i> and <i>dge</i> , and words that follow the Double Trouble Rule.
Unit 13: Our Plants	A: some B: find, are, like, see, new	Underline 2-sound blends – Students should underline each letter in the blend separately since each letter in a blend spells its own sound.
Unit 14: The Potluck	A: think, put, after, take B: eat, make, play, see	Draw a line to divide two-syllable words into syllables – Students can underline the vowel letters in words first and then divide the word so that there are two Closed Syllables.
Unit 15: The Attic	A: made, old, open, read B: away, find, into, saw, under	Draw a line to divide two-syllable words into syllables – Students can underline the vowel letters in words first and then divide the word so that there are two Closed Syllables.
Unit 16: The Picnic	A: after, could, first, laugh B: blue, good, see, under	Underline Open Syllable words.



BLAST PASSAGE	WORDS TO PREVIEW <i>List A is 1st-3rd Grade Dolch Words. List B is pre-primer and primer Dolch words.</i>	DIFFERENTIATION SUGGESTIONS <i>Have the students find and mark these skills before reading the passage.</i>
Unit 17: Robots	A: about, many, think, use B: find, good, play, say	Draw a line to divide two-syllable words into syllables – Students can underline the vowel letters in words first and then divide the word. They should read the word aloud to see if it makes sense and move the line if necessary.
Unit 18: The Puppet Show	A: first, laugh, show, thinks B: eat, good, say, who	Circle the vowels flexing to <i>schwa</i> – Students can underline the vowel letters in words and divide them into syllables. They should read the word out loud and try to identify if there is a vowel flexing to <i>schwa</i> . If there is a vowel flexing to <i>schwa</i> , students should circle it.
Unit 19: Take a Trip	A: far B: too, blue, find, new, play	Underline the Vowel-Consonant-e – Students can underline the vowel and the e and connect them with a scoop in words that have the VCE pattern.
Unit 20: Camping	A: after, better, keep B: find, see, are	Underline the Vowel-Consonant-e – Students can look for the vowel letters and draw a line to divide words into syllables. They can underline the vowel and the e and connect them with a scoop in words that have the VCE pattern.
Unit 21: The Beach	A: always, walk B: are, find	Underline Vowel Teams – Students can underline the vowel teams ee , ea , ai and ay . The letters of the vowel team should be underlined together.
Unit 22: Trick or Treat	A: does, give, goes, laugh B: <i>none</i>	Underline Vowel Teams – Students can underline the vowel teams igh and oa . The letters of the vowel team should be underlined together.
Unit 23: Ted’s Bad Day	A: done, far, better B: find, blue	Circle <i>suffix -ed</i> – Students can circle the <i>suffix -ed</i> at the end of words.
Unit 24: Ruby’s Dream	A: once B: <i>none</i>	Circle the inflectional endings – Students can circle the inflectional endings -er , -ed , -s , -es and -ing at the end of words.
Unit 25: My Siblings	A: never B: blue, new, are, find	Teachers can direct students to mark any previously learned skills they are still struggling with.



On the Ship

Sam, Dad, and I take a trip on a ship. We take a cab to the ship and get on. The ship is big, and there is a lot to do. Sam and I shop for a hat. Dad and I sit on a cot and fish. I get three fish in a flash. One is too big, so my rod snaps. I can get a new rod if I dash to the shop. At the shop, I see Sam. We find Dad, and we all go eat. The hot ham dish is good! We have jam and figs too. The figs give Sam a rash. They go in the trash, and we go fish with my new rod. I will miss the ship when we get off.

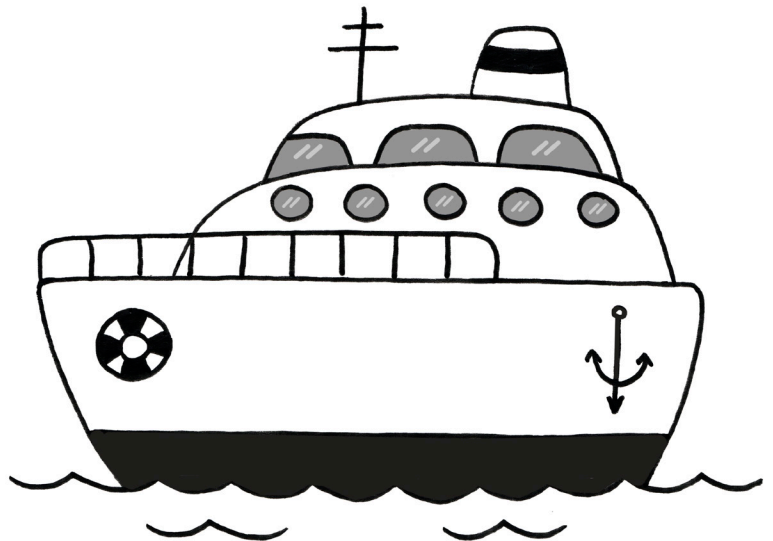

The Rush to Camp

Gus was in a rush to get to camp. He could take a bus. He could grab a cab. He had no cash, so he had to run fast! Gus ran, but he did trip and land in the mud. When he got to camp, his dad had a big grin, but his dad saw the mud on his hands. Gus said, "I had no cash, so I had to run in the hot sun. I did slip in a rut, so now I have mud on my hands." His dad was not mad. He gave Gus a hug and said to hop in the tub. When Gus got rid of the mud, he had fun at camp. His dad gave him cash, so Gus could take a cab when he must go.

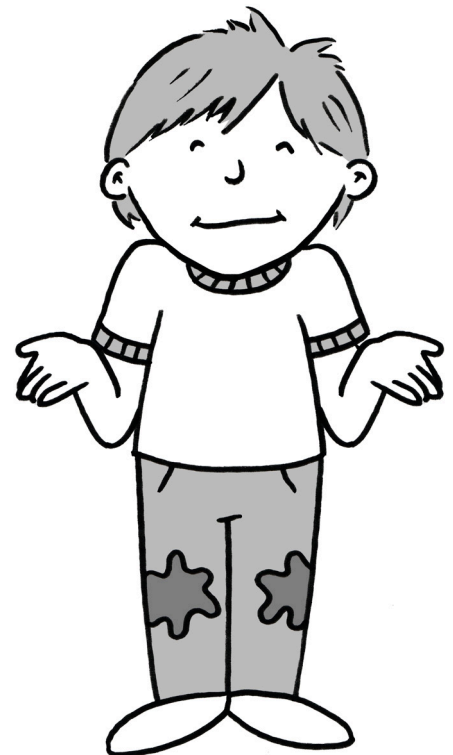

A New Dog

Thad has a wish for a dog. He saw a slim tan dog at the shop. His mom said that a dog can be fun for a kid, but Thad will have to do a lot with the dog. Thad must walk him on the path and take him to the vet. Thad will have to give the dog a hot bath in the tub, but not too hot. Then, Thad must brush the dog. Thad will have to fill the dog dish with mush. If not, the dog will get too thin. The dog will rush and dash, and then he will take a nap. He will want a bed to nap on. Dogs can just nap on the rug, but a soft pad is best. Thad still has a wish for a dog. He will go to the shop with his mom to get the tan dog.

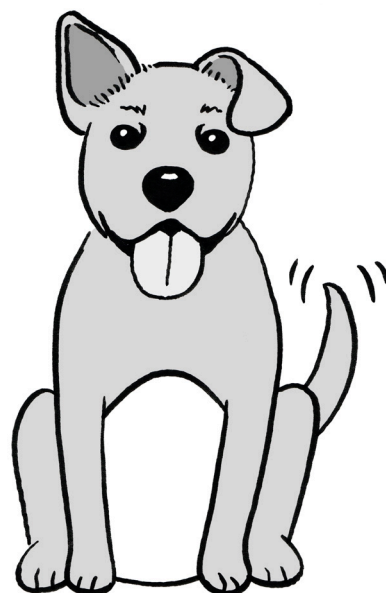

Hens and Pigs

Jed has pigs and hens on his land. Jed's hens live in a big pen. The hens yak and strut in the pen. The pen has a shed in it. This is where the hens have beds. They can go in the shed to nap and to get out of the sun. Hens like to eat pests like grubs and bugs. Yum!

The pig pen is just to the west of the hen shed. The pig pen has a pit of mud at one end. The pigs like to play, jump, and jog in the wet mud. They like to eat slop out of a vat, but they beg Jed for figs and yams.

Jed's hens and pigs are not pets. He can pat them, but they do nip. Jed's pet is his cat.

The cat is his pal and will go to the hen shed and the pig pen with Jed. Then she sits in the sun with Jed, and they rest.

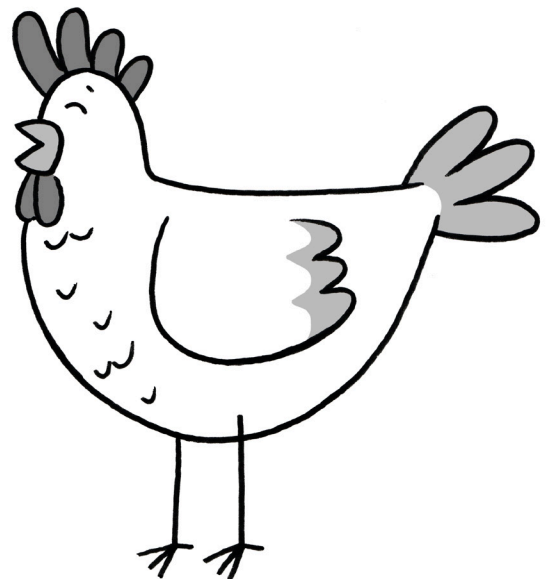

The Chimp

Chip the chimp sits on a branch in an elm. For lunch, he will munch and crunch on bugs. Then he will chat with his sis. They will have so much fun that Chip's chum will stop by too. The pals will jump from branch to branch. Chip will thump his chest and so will his sis and his pal. Next, the chimps will whip up a bit to eat and chit-chat. They will chat and say which bugs are best to munch on and which branch is best to rest on when the sun sets. Chip's sis will see a dot on Chip's chin and ask Chip if it is a bug. Chip will say it is a bit of mud and brush it off. On a whim, the chimps will go for a dip in the pond. When the sun sets, they will get a chill and find the best branch to rest on. It is such fun to be a chimp!

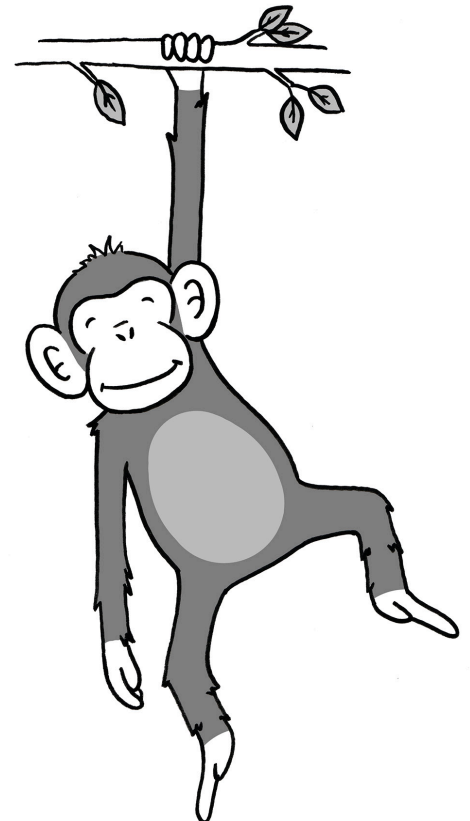

Tick Tock

Nick must take the duck and the chick to the vet at ten.

Tick tock. Nick must pack a quick snack to take with him. He runs to the shack to find the duck. The duck quacks so much that Nick must give him a stick from his snack pack to lick.

Then he must check the truck. The truck is stuck in the muck.

Nick can see Rick by the shed. Can Rick help? Yes, Rick can help tug the truck out of the muck! They tug the truck back

to the shack. Now, Nick must put the duck in the truck bed.

Then they go down the track to pick up the chick. He tucks

the chick in a box. Tick tock. It is ten! Nick and Rick bring the duck and the chick to the vet.

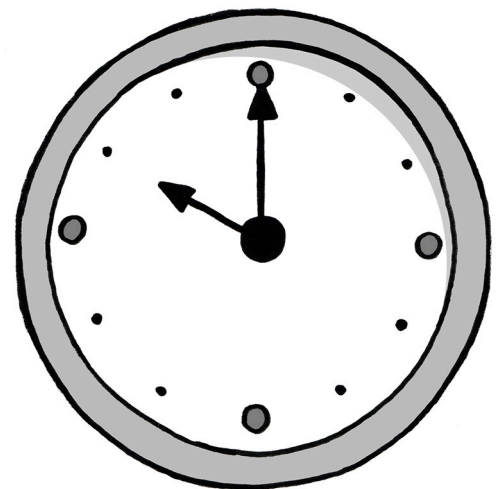

Fudge

Madge made a batch of fudge in the big Dutch pot. She put in a pinch of this and a dash of that. I had a wedge of it to judge if it was good. It was good! The fudge was soft, but it did not melt in my hand. Then the fudge made the edge of my hand itch. I got a red patch on my neck and it did itch. The fudge was good, but it had nuts! I went to fetch mom. Mom would give me a shot so I would not get sick. I said to Madge, "The fudge is good, but it has nuts." Madge put the fudge up on the ledge, and I sat down for a bit. When the itch and the red patch left, I felt top notch. Madge and I made a new batch of fudge with no nuts for me to eat. Yum!

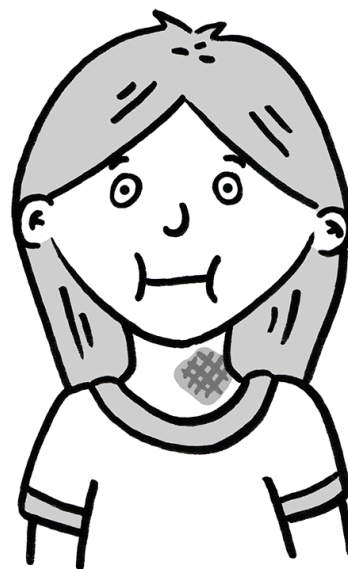

The Fall

When I went to play ball, my mom did tell me not to run too fast. She did not want me to miss a step and trip. I did trip when I went to catch a pass from a pal in class. I fell down in the tall grass. My leg had a cut, and I had grass stuck in the cuff of my pants. I did not want to call for my mom. I did not want her to fuss and say, "What a mess!" My pal did pull me up and help me to the wall. I sat down to let my leg rest. Then, my mom came and saw me on the wall. She gave my leg a kiss and said the mess was not bad.

She did dab the cut with a cloth and brush the grass from the cuff. Then, we went down the hill and got new pants at the mall.

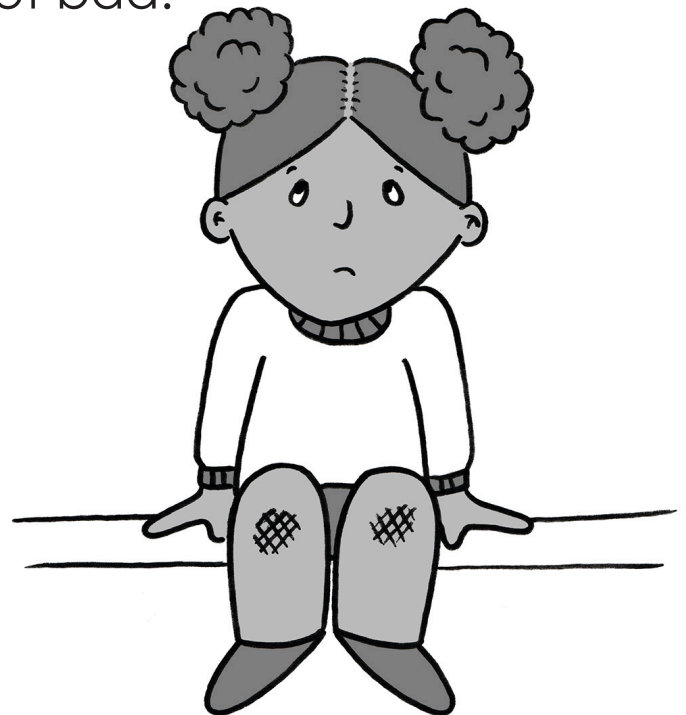

A Ball

A ball can be fun. You can toss a ball. You can pitch a ball. You can kick a ball. You can catch a ball, too. You can catch a small ball with one hand and a big ball with two hands. Try not to miss the ball. You may have to budge from one spot to catch it. Duck if the ball is too fast for you. Then, just pick up the ball from the grass. If you have a dog, the dog can fetch the ball from the grass. You can hit the ball with a bat. If you do not have a bat, you can hit the ball with the edge of a thick stick. It is best to ask a pal to play. A pal can toss the ball to you, and you can pass the ball back. You can play a match of kick ball or dodge ball with a pal too. Pick a good round ball, and all will be well!

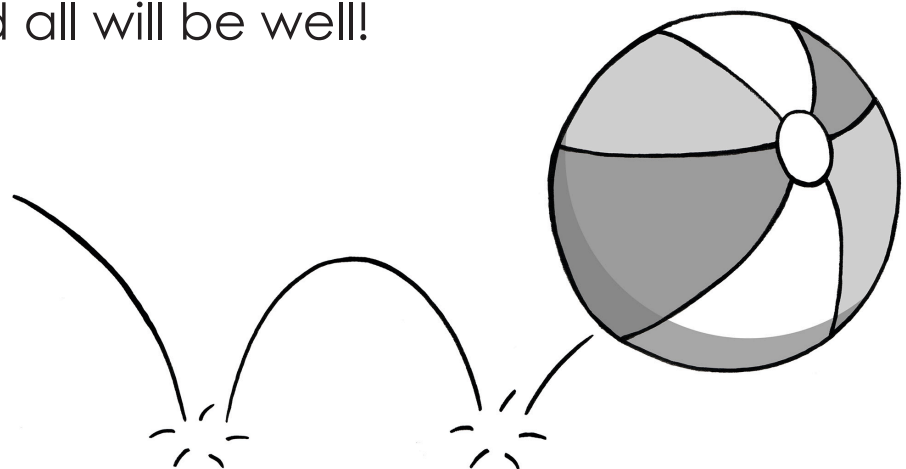

Our Plants

When it is hot and the sun is up, I find lush plants on our plot of land. Some are soft like moss and some are stiff. The plants on the edge of the pond like to be kept damp. They look like thin twigs in the wet sand. Frogs jump and catch the bugs that land on the stems. To the left of the pond is a hill with a grand shrub. There is a nest with six eggs on one branch. In the fall, the shrub has red and brown specks. Next to the shrub is a tall plant. We like to camp in a tent by that plant. We pack a lamp to see past dusk and fresh grub to snack on. The plants are lush when it is hot and there is a lot of sun, but the plants do not like frost. Some plants are lost when there is a chill. Then new plants come back as soon as the frost ends.

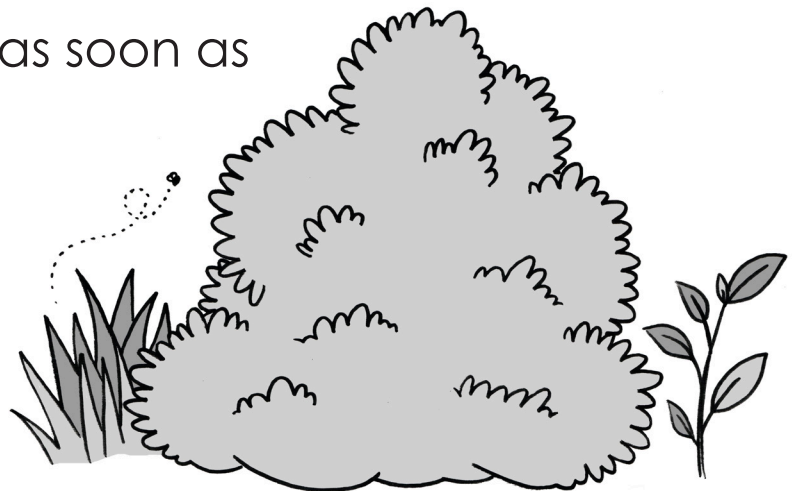

The Potluck

Our class will have a potluck after the math test. Robin will make ham and eggs. Edwin will make a catfish sandwich. I think I will make a pumpkin dish. The setup will be quick. We will put down plastic cups and fabric napkins. When we finish, we will toss the cups in the trashcan and set the napkins back in the picnic box. After we eat, we will play catch on the blacktop. Then, we will take the path to the hilltop to see the sunset. We can have a contest to run to the tiptop of the hill. At the top, there is a windmill we can sit by to rest. Edwin will insist that we stop to see the sun dip down. We will not panic if we must run back at dusk.

Then we will pack up. What a splendid potluck picnic it will be!

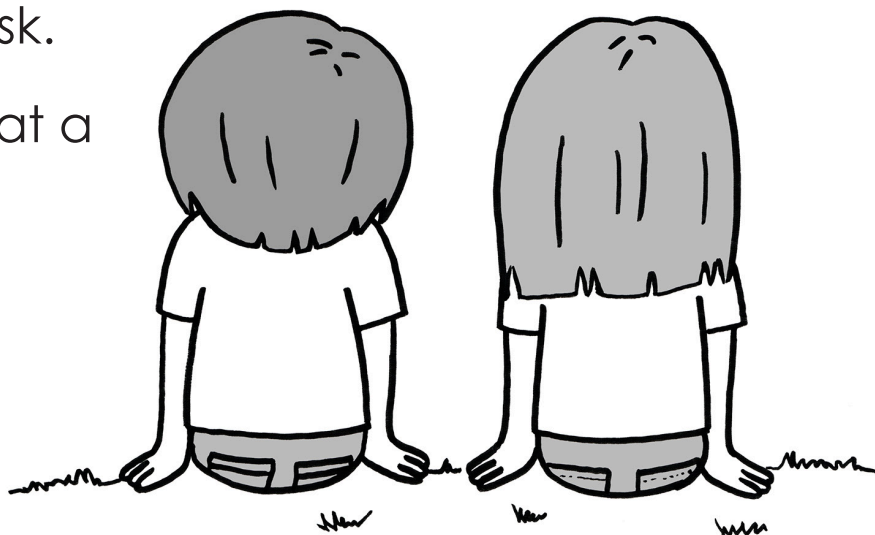

WORDS TO PREVIEW:

made, old, open, read

BLAST UNIT 15Spelling 2-Syllable Words
with Closed Syllables**170 words**

The Attic

Calvin went up to the cabin's attic to find his mom's old comics. What would you expect him to find up there? Not just comics! He saw a chipmunk run by him in a flash. This made Calvin panic, and he got the hiccups. He fell into a plastic trashcan with lots of tennis balls. When he got out, he saw a plastic rabbit on top of an old laptop. He had to brush away a cobweb in disgust. At last, he saw ten classic comics in a red fabric handbag under a small bathtub. He came down from the attic and sat with the comics and a snack. He went to flip a comic open and hit his glass. What luck! The milk did not spill on the comics. His mom would be upset if they got wet. He said he would just read them at his desk. Calvin ate his sandwich and then went down the hall to his desk with the comics. He will read them all!

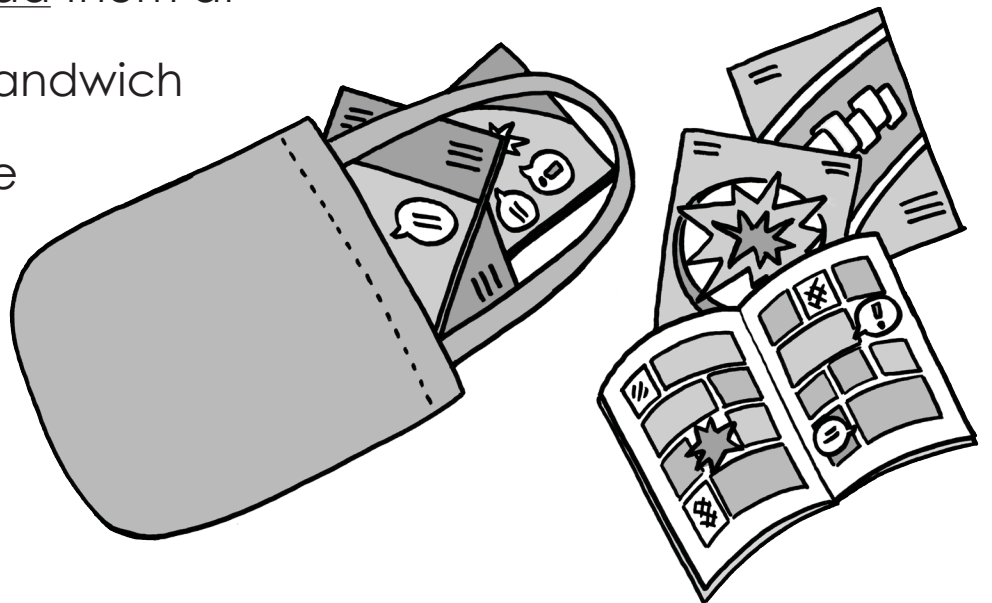

The Picnic

Patrick and Flo went on a picnic. First, they had to unpack. Patrick said, "Please go get the plastic cloth and the backpack from the pickup truck. I will try to find a good spot for us." Patrick did inspect the grass and got a spot with no rocks. Flo set the cloth down.

They had lunch under the blue sky. First, they had some eggnog from a can. The top was stuck, so they had to pry it off. Then, they had a fish fry and split a relish and pumpkin sandwich. Flo said that the sandwich was so good that Patrick could be a pro.

After lunch, Patrick did panic when a big insect with six legs sat in a cobweb next to him. With a little jump and a yell, he put a napkin on top of it and ran! Patrick did try not to cry.

Flo said, "Why are you upset, Patrick?"

"There was a bug with six legs by me,"

Patrick said with a shy grin.

Flo put the insect in the public trashcan. It was funny, but she did not laugh at him. They sat back down by the cloth to see the sunset.

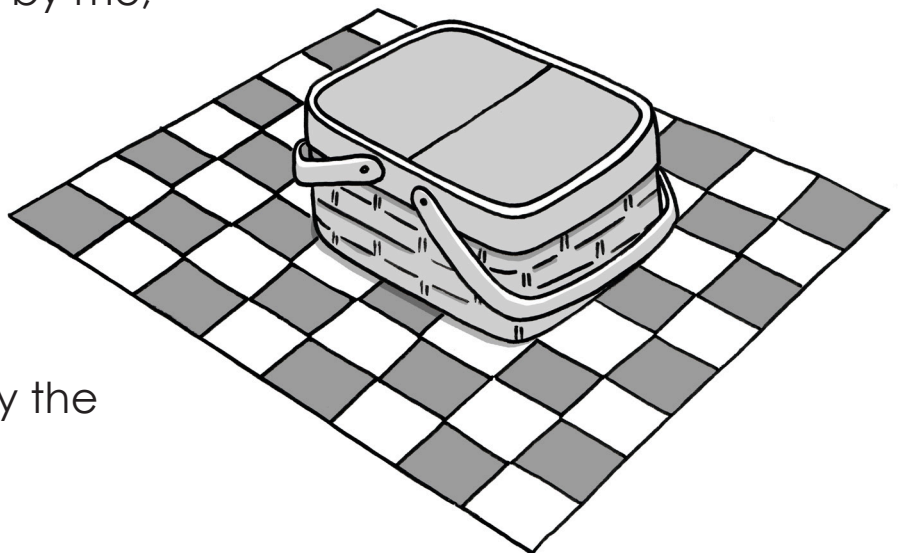

WORDS TO PREVIEW:

about, many, think, use

.....

BLAST UNIT 17

Two-Syllable Words
with Open and Closed
Syllables & Chunking

187 words

Robots

You can program robots to do many things. Robots can do basic things like say “hello.” They can take a photo and play music. Robots could be good at making a snack as you are taking a bath.

Robots can add and subtract to find a result. They can even do complex math. You can program robots to protect a secret camp or to plan a trip to Fresno. Some robots are silent, but some will respond if you chat with them. You can program robots to tell you about things like new events or the lunch menu.

Robots can do many things, but there is a limit to what they can do.

Robots cannot relax. They cannot be in a hotdog tasting event. They will not use napkins. Robots cannot get sick with a virus and cannot hiccup.

Insects cannot sting them. Robots will not

have a tantrum or get upset if they

get a zero on a test. They will not brag

about winning a math contest. You can

program a robot to do many things, but

they cannot think or act with no help.

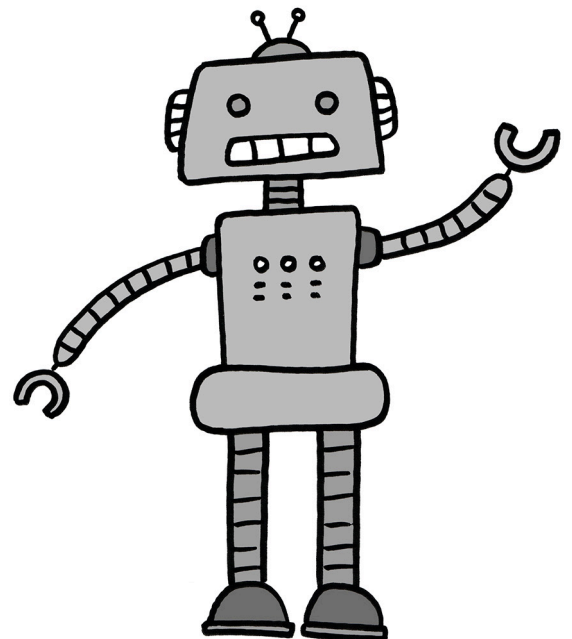

The Puppet Show

There is a puppet show at six in the local children's hall across the canal. You may want to see it. I even have extra tickets for the second show at seven if you would like to go. I went to the latest show, so I can tell you about it. First, you will see a chimp puppet on a canvas hammock. He will be munching on some bacon. Then, a cricket puppet will come hopping across the grass to a picnic blanket. It will pick at the spinach salad that the humans put down. You will see a panda puppet in the branches chomping on stems and a piglet puppet hunting for bugs. The piglet thinks the cricket would be good to eat. He is about to chomp down, but at that instant, the panda falls off the branch and happens to land in the spinach salad! The puppets all laugh and the children all clap. At the end, the panel is taken down and the humans who pretend to be the puppets say hello. There is so much talent in this show. You will not regret it if you happen to go.



Take a Trip

If you do not want to be stuck at home this fall, plan a trip. Pick a date, select a spot, and go. You can stick close to home or travel the globe to a distant land. If you stick close, you could drive. If you go far, you could ride a bus, take a plane, or even fly in a blimp. You could visit a new state like Texas or a spot like the Grand Canyon. You could attend an event in your home state too. Hit the blacktop and plan for a nonstop trip. Safe travels!

Make a note of things you want to do on your quest. It can be fun to branch out and try new things, not the same things you do at home. You may want to see a local ball game or a play about a brave robot. If you want to have a picnic, you could make a snack or a sandwich and take it with you. You could be brave and try a new plate for lunch. If you want some milk or punch on the go, take time to bring a thermos.

You do not have to spend a lot. You and your pal could ride a bike to the lake and fly a kite in the blue sky or just bring a blanket and laze for a moment. You could go for a swim, catch a wave, or run in a zigzag on the white sand. If you go on a hike, bring your compass so you do not get lost. You may even find a cave, canyon, or tunnel to inspect.

So, save your extra nickels in a can, and then fetch them and make it happen. I hope you rave about your trip when you come back.

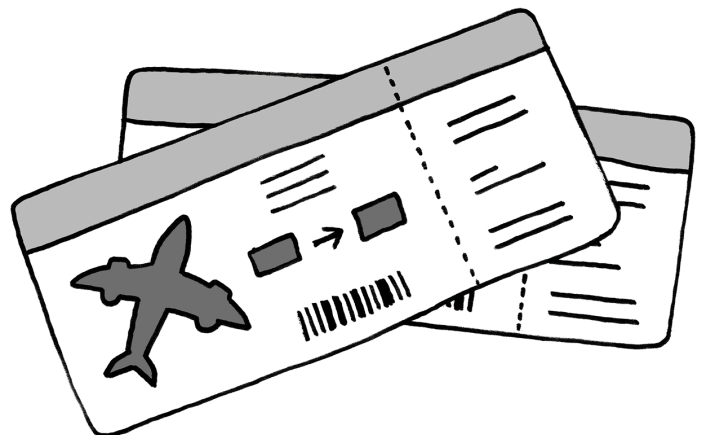

Camping

Jolene and Blake want to take a camping trip to escape for a while. They get the tent out of the basement and pack the van. They invite Jake to come with them, but he has plans to see the parade. When Jolene and Blake get there, they locate a good spot to pitch the tent and complete the campsite setup. Jolene brings a mattress to inflate inside the tent. It is better if she puts the mattress on the grass and not on concrete. After the campsite is set, they go on a hike to see the landscape. They find a path on the map and begin. It is good to be out in the sunshine! At lunchtime, they have a homemade sandwich and a pancake made over an open flame. On the path back to camp, they have a small debate about where to go left, but Jolene has a compass and they find the campsite. It is late when they get back. They ignite a log with a match and grill hotdogs on sticks. At bedtime, they are careful to put out the flame and zip up the tent to keep safe. When it is time to go home, they are polite and pick up their trash. They take down the tent and pile into the van. Then, they drive home.



The Beach

Do not wait. On the next sunny day, go to a beach. The beach could be at the lake or at the sea. There are many ways to spend a day at the beach. If you just want to relax, set up a chair and read. You could read an essay or a novel. It can be good to just feel the wind in your hair and the sand beneath your feet. Please be careful not to fall asleep in the sun and always have sunscreen on.

If you want to have a playful day, there are plenty of things to do at the beach. Go for a walk and get your feet messy with grains of sand. Go for a swim where it is clear from seaweed. Jump in and leap over a tall wave. Play frisbee with a pal in the sunshine. You can finish by eating your meal on a blanket.

You will find that there is a lot to do and see at the beach. You may see snails in shells or catch a peek at fish in the reef. If the sea is clean and clear and you are lucky, you may see eels deep down. At a lake, you may run into some crayfish or catfish. If you just need to get away, find a beach nearby and go. You will be happy you went!



Trick or Treat

While some kids like to trick-or-treat, Randy does not. His pal Betsy squeals with delight at white sheets that float in the trees and black bats that swing from the branches, but these things give Randy a fright. He does not like how frightful the streets look when daylight ends, but he does like the free candy he gets. So, he grabs a flashlight and goes down the road to trick-or-treat with Betsy.

Betsy tells Randy his light will reveal that there is no need to be afraid. The thing Randy sees might look like a pile of bones, but in the beam of the flashlight, it is just a pile of sticks. Randy thinks there is moaning and groaning to the right, but in the light, it is just a swing swaying in the wind.

Randy and Betsy get to a driveway and walk up the steps. A tall man in a raincoat with a cloak and a top hat hands them some candy. This brightens their night, and they go on. Next, they approach a lady in a green dress and tight socks with a toad made of foam in her right hand. She hands them a pack of gum.

Randy is feeling brave. "No sight can frighten me," he boasts. He stands upright and puts the flashlight away in his coat pocket.

Wait, where did Betsy go? "Hi!" she yells as she jumps out from the oak tree. Randy goes stiff with fright. Then, he grabs his flashlight and sees it is just Betsy. They laugh. They take their load of candy home and have hot cocoa. Randy is glad to be toasty and safe inside.



Ted's Bad Day

Friday was not a good day for Ted. He woke up with the sun, checked the clock, and saw that it was nine. He was late! Ted landed on a plastic game token as he jumped out of bed, so he limped down the hall. Ted wanted eggs. He opened the fridge to find them, whisked them in a dish, and then dumped them into a hot pan. While he waited, he made toast. Then Ted brushed his teeth, packed his backpack, and left for class.

Ted missed the math test and had to take it at lunch. He munched on his sandwich while he added seven and three. He was just about done when he bumped his glass and spilled milk on the test. Ted was lucky. Miss Best could still read the test and he passed. Ted leaped away from his desk and ran. He made it before the kickball game ended. He played for one inning. Ted kicked the ball far but stained his pants when he slid into home plate.

Ted painted in the next class. He mixed red and blue paint. As he squished the paint out, it sprayed on his smock and in his hair. His pal fetched a napkin and helped Ted clean up. What a day! Ted could not wait to go home.

On his walk home, Ted dented his lunchbox when it fell on a rock. By now, Ted was fed up. He jumped up the steps and went inside. His mom had left a cupcake as a snack with a note that said, "I hope you had a good day. From, Mom." That made Ted smile. He ate the cupcake and felt much better.



Ruby's Dreams

Steve's dog Ruby twitched in her sleep. Steve wanted to know what Ruby was dreaming about. Was she dreaming about the cats they had seen on their walk? While Steve and Ruby rested on the bench, three cats across the street had flicked their tails at Ruby. She had wanted to chase them, but Steve kept a tight grip on her leash. Maybe Ruby was chasing after them in her dream.

"What do dogs dream about?" Steve asked himself. Steve often dreamed of things he wished he could do. In some dreams, Steve was a painter or a singer. In some dreams, Steve was a baseball player, winning the game as his coaches clapped. One time, Steve dreamed he could run faster than a speeding train and jump higher than the tallest wall. Not all of Steve's dreams were good dreams. Once, in a bad dream, Steve was falling out of the sky while gripping a trumpet. He ended up landing in a soft pile of boxes, but it was frightful!

Steve did not think Ruby had the same dreams. Ruby might dream of eating treats or catching a ball or chasing foxes around the trees. She did not dream of acting in a play or flying a plane like Steve might. Steve could not know what she was dreaming of, but he trusted Ruby was dreaming a good dream. When she woke up, she stretched and wagged her tail, begging Steve to take her on a walk.



My Siblings

I have five siblings and each one is taller than the next. Let's begin with Tim. He is the tallest. He likes sailing and has no fear of the deep blue sea. When he takes me on the boat with him, it feels like we go faster than a speeding train.

Sammy is not as tall as Tim, but he is still taller than the rest of us. Last week, Sammy wanted to make a frozen soda treat. He did not know that soda expands in the freezer until the can cracked open. The soda slush was a mess, but tasty!

Next is Blake. He is the same size Tim was when Tim was ten. Mom adds patches to Tim's old pants for Blake. I think Blake wishes he could shop for new pants, but he does not whine about it. He is silent unless he is cheering for his baseball team.

My sis Beth is smaller than Tim, Sammy, and Blake, but she is taller than Gail. When Beth plans to spend time with her pals, Mom tells her it would be polite to invite Gail too. If Beth is going out, Gail always goes with her. I think it is funny because Beth and Gail are not alike. Beth likes to try new things and visit her pals. Gail likes to stay inside and read. They have one thing in common. They both like to play hide and seek with me. I always win because I can hide in tiny spots.

I am the smallest one of the bunch. Last year, I was upset that I could not do the same things as my siblings. This year,

I am older and wiser. My teacher tells me that when you are upset, you can try to find the bright side. Mom never asks me to put away the dishes because I cannot reach the shelf!



COMPREHENSION QUESTIONS FOR BLAST PASSAGES

All questions are literal comprehension questions except those marked with an asterisk (*). These starred questions are inferential in nature.

UNIT 4: On the Ship

1. How do they get to the ship? (A: They get to the ship in a cab.)
2. What do they sit on while they fish? (A: They sit on a cot to fish.)
3. What do they eat with the ham? (A: They eat jam and figs with the ham.)
4. *Why do you think the figs had to go in the trash? (A: I think they put the figs in the trash because they gave Sam a rash.)

UNIT 5: The Rush to Camp

1. Why didn't Gus take a cab or a bus? (A: Gus didn't take a cab or bus because he didn't have any cash.)
2. What happened to Gus's hands when he fell? (A: Gus's hands got mud on them when he fell.)
3. *How do you think Gus knew his dad was not mad? (A: I think Gus knew his dad was not mad because he hugged Gus.)
4. How will Gus get home after camp? (A: Gus's dad gave him cash to take a cab home.)

UNIT 6: A New Dog

1. What color is the dog Thad wished for? (A: Thad wished for a tan dog.)
2. Where will Thad have to walk the dog? (A: Thad will have to walk the dog on the path.)
3. What does Thad have to put in the dog dish? (A: Thad has to put mush in the dog dish.)
4. *Why do you think the dog will want a nap? (A: I think the dog will want a nap because he will rush and dash and get tired.)

UNIT 7: Hens and Pigs

1. Where is the hens' shed? (A: The hens' shed is in a big pen.)
2. What do the hens eat? (A: The hens like to eat pests like grubs and bugs.)
3. *Why do you think the pigs beg for figs and yams? (A: I think the pigs beg for figs and yams because maybe they like them better than the slop in the vat.)
4. What do Jed and his cat do in the sun? (A: They sit and rest in the sun.)



UNIT 8: The Chimp

1. What will the chimp eat for lunch? (A: He will eat bugs for lunch.)
2. What will Chip's sis think she sees on his chin? (A: She will think she sees a bug on Chip's chin.)
3. What is really on Chip's chin? (A: It is really a bit of mud.)
4. *Why do you think the chimps will get a chill? (A: I think they will get a chill because they will be wet from the pond and the sun will not keep them warm anymore.)

UNIT 9: Tick Tock

1. Where does Nick have to take the duck and the chick? (A: He has to take them to the vet.)
2. *Why do you think Nick needs help from Rick? (A: I think he needs help from Rick because it will take two people to tug the truck out of the muck.)
3. What does Nick put the chick in? (A: Nick puts the chick in a box.)
4. Did Nick and Rick get the duck and the chick to the vet on time? (A: Yes, they got them to the vet at ten.)

UNIT 10: Fudge

1. What did Madge make the fudge in? (A: She made the fudge in a big Dutch pot.)
2. *What do you think made the narrator's neck itch? (A: I think the nuts in the fudge made the narrator's neck itch because she got the red patch after eating the fudge with nuts.)
3. How did the narrator's mom help? (A: She gave the narrator a shot.)
4. What kind of fudge did they make at the end of the story? (A: They made fudge without nuts.)

UNIT 11: The Fall

1. When did the girl fall? (A: She fell when she went to catch a pass from a pal.)
2. Where did the girl get a cut? (A: She got a cut on her leg.)
3. *Do you think her mom was mad? (A: No, I don't think her mom was mad because the mom gave her a kiss on the leg.)
4. What did mom dab the cut with? (A: Mom dabbed the cut with a cloth.)



UNIT 12: A Ball

1. *Do you think the author likes playing with a ball? How do you know? (A: I think the author likes playing with a ball because he/she lists many different ways to play with a ball. The author also says, "A ball can be fun.")
2. If a ball is too fast for you, what should you do? (A: If a ball is too fast for you, you should duck.)
3. What can you use to hit the ball if you don't have a bat? (A: You can hit the ball with a thick stick.)
4. What games can you play with a pal? (A: You can play kick ball or dodge ball, or you can just pass it back and forth.)

UNIT 13: Our Plants

1. Where are the plants that can look like thin twigs? (A: The plants that look like thin twigs are in the wet sand on the edge of the pond.)
2. What is to the left of the pond? (A: A hill with a grand shrub is to the left of the pond.)
3. When does the shrub have red and brown specks? (A: The shrub has red and brown specks in the fall.)
4. *Why do you think some plants are lost when there is a chill? (A: I think that some plants are lost in a chill because they could freeze, which could hurt them.)

UNIT 14: The Potluck

1. When will the class have a potluck? (A: The class will have a potluck after the math test.)
2. Where will the napkin go after they finish eating? (A: The napkin will go back in the picnic box.)
3. What is at the top of the hill? (A: A windmill is at the top of the hill.)
4. *Why do you think they will need to rest at the top? (A: I think they will need to rest because they just ran up to the tiptop of the hill and they are tired.)

UNIT 15: The Attic

1. Why did Calvin go up to the attic? (A: He went up to the attic to find his mom's old comics.)
2. What ran past Calvin quickly? (A: A chipmunk ran past Calvin quickly.)
3. Where did Calvin find the comics? (A: He found the comics in a red fabric handbag under a small bathtub.)
4. *Why do you think Calvin waited to look at his comic until after he finished eating? (A: I think Calvin waited because he already spilled his milk, and he was worried about getting his food on the comics.)



UNIT 16: The Picnic

1. What did Patrick ask Flo to get out of the truck? (A: Patrick asked Flo to get the plastic cloth and the backpack from the truck.)
2. How did Patrick and Flo get the top off the can of eggnog? (A: They had to pry the top off.)
3. Why did Patrick jump and yell? (A: He jumped and yelled because he saw an insect next to him in a cobweb.)
4. *Do you think Flo was scared of the insect? How do you know? (A: I don't think she was scared of the insect because she picked the insect up and put it in the trashcan. She also didn't yell or jump like Patrick.)

UNIT 17: Robots

1. What might a robot do for you while you take a bath? (A: A robot might make you a snack while you take a bath.)
2. Can you have a conversation with all robots? (A: No, only some robots can talk.)
3. What are two things a robot cannot do? (A: A robot cannot relax, eat a hotdog, use a napkin, get sick, hiccup, get stung by an insect, have a tantrum or get upset, or brag.)
4. *What is one thing that robots can't do that you wish you couldn't do? (A: Robots can't get sick or hiccup, and I wish I couldn't get sick or get the hiccups either.)

UNIT 18: The Puppet Show

1. What time is the second puppet show? (A: The second puppet show is at seven.)
2. What does the chimp puppet eat during the puppet show? (A: The chimp puppet eats bacon.)
3. *Why do you think the piglet puppet doesn't get to eat the cricket? (A: The piglet puppet probably doesn't get to eat the cricket because the panda falls off the branch, which distracts him.)
4. Where does the panda land? (A: The panda puppet lands in the spinach salad.)

UNIT 19: Take a Trip

1. How can you travel if you want to go far from home? (A: You could travel by bus, plane, or a blimp if you want to go far from home.)
2. What does the passage say you could do to be brave? (A: The passage says you can be brave by trying a new food for lunch.)
3. What are two things you can do if you go to a lake? (A: If you go to a lake, you could fly a kite, laze on a blanket, go for a swim, catch a wave, or run in a zigzag on the white sand.)
4. *What do you think "save your nickels" really means? (A: I think "save your nickels" really means to save your money.)



UNIT 20: Camping

1. Where is the best spot to set up the tent with the mattress? (A: The best spot to set up the tent is on the grass, not on the concrete.)
2. What does Jolene use to help them figure out where to turn? (A: Jolene uses a compass to know where to turn.)
3. Why do they zip up the tent at bedtime? (A: They zip up the tent at bedtime to be safe.)
4. *Why do you think picking up their trash is polite? (A: I think picking up their trash is polite because then the campsite will be clean for the next people who camp there.)

UNIT 21: The Beach

1. Where could you find a beach? (A: You could find a beach at the lake or at the sea.)
2. *Why do you think the author tells you not to fall asleep in the sun? (A: I think the author tells us not to fall asleep in the sun because we could get sunburned.)
3. What are two things you could do at a beach? (A: At the beach, you can go for a walk, go for a swim, jump in and leap over a tall wave, play frisbee, or have a picnic on a blanket.)
4. What might you see deep down in the sea? (A: You might see eels deep down in the sea.)

UNIT 22: Trick or Treat

1. Why does Randy go trick-or-treating with Betsy even though he is scared? (A: Randy goes trick-or-treating with Betsy even though he is scared because he likes the candy.)
2. What is the lady in the green dress holding in her hand? (A: The lady in the green dress is holding a toad made of foam.)
3. *Do you think Randy was mad at Betsy for scaring him? How do you know? (A: No, I don't think Randy was mad at Betsy for scaring him because they laughed together after.)
4. What do Randy and Betsy do once they get home with their candy? (A: They drink hot cocoa once they get home.)

UNIT 23: Ted's Bad Day

1. What happened when Ted jumped out of bed? (A: When Ted jumped out of bed, he stepped on a plastic game token.)
2. How did Ted do on the math test? (A: Ted passed the math test.)
3. *What color paint do you think ended up on Ted's smock and hair? (A: I think he had purple paint on his smock and hair because red and blue make purple.)
4. What made Ted feel better after his bad day? (A: Ted's mom left him a nice note and a cupcake, and that made him feel better.)



UNIT 24: Ruby's Dreams

1. Who did Ruby want to chase during her walk? (**A:** Ruby wanted to chase three cats that flicked their tails at her.)
2. In one of Steve's dreams, he could run faster than what? (**A:** Steve dreamed he could run faster than a speeding train.)
3. What was Steve holding in the dream where he was falling out of the sky? (**A:** Steve was holding a trumpet while he was falling.)
4. *Why do you think Steve couldn't know what Ruby was really dreaming about? (**A:** I think Steve couldn't really know what Ruby was dreaming about because dogs can't talk.)

UNIT 25: My Siblings

1. What did Sammy put in the freezer that made a mess? (**A:** Sammy put soda in the freezer, and the can cracked open and made a mess.)
2. *Why do you think Mom needs to add patches to Tim's old pants for Blake? (**A:** I think Mom needs to add patches because Tim must have worn holes in the pants when they were his.)
3. Which brother or sister likes to stay inside and read? (**A:** Gail is the sister that likes to stay inside and read.)
4. Why can't the narrator help put the dishes away? (**A:** The narrator can't help put the dishes away because he/she is too short to reach the shelf.)



BLAST UNIT 10
Trigraphs -tch & -dge
148 words

WORDS TO PREVIEW:

A: made, put, would, give

B: good, my, so, me, new

Fudge

Madge made a batch of fudge in the big Dutch pot. Madge put in a pinch of this and a dash of that. I had a wedge of it to judge if it was good. It was good! The fudge was soft,

Underline the trigraph **-tch** or **-dge** with one line. Then read the words.

Madge
batch
fudge

Available in Blast Online's supplemental resources.

The differentiated *Blast Passages* offer additional support for students struggling to read the passages accurately and/or fluently.

QUICK FACTS

1. Students practice with new skill words before reading the passage.
2. All Heart Words students learned in *Blast* are marked with a heart.
3. All Dolch words not taught in *Blast* are provided in Words to Preview and appear underlined in the passage.

When the itch and the red patch left, I felt top notch. Madge and I made a new batch of fudge for me. Yum!



notch



A 15-MINUTE/DAY SUPPLEMENT FOR 1ST GRADE

Blast Foundations is a set of 25 units, designed for emerging readers in 1st grade. Each unit has five lessons, and each lesson is designed to be taught in approximately 15-20 minutes. *Blast Foundations* is often used as a whole group, daily supplement to core reading instruction.

In *Blast Foundations*, students learn and practice letter-sound correspondences, phonemic and phonological awareness, high-frequency word fluency, phonics knowledge, and spelling. Schools where the core reading programs do not provide a sufficient dose of foundational skills instruction often add *Blast* to ensure that their young students become efficient, effective decoders.

Blast can also be used as a small-group, early intervention for older students who still struggle with basic phonics or with older ELL or special education students who need to acquire foundational reading skills such as letter-sound correspondence and the basic structure of English words.

Blast Foundations lessons can be completed in 16-25 weeks depending on the amount of time that can be dedicated to instruction each day. *Blast Online* and the student manipulatives are designed to make instruction exciting and effective.

Download a sample lesson at reallygreatreading.com/samplelesson

PHONICS CONCEPT

3 BUILD REAL WORDS WITH DIGRAPH SH

1 DO: Build rash
Explain that students will build real words with digraph sh.
Say the word rash.
Stretch the phonemes - /r/ /ə/ /sh/, rash.
Place one colored tile on the board for each sound in rash while saying the phonemes - /r/ /ə/ /sh/.

Spell each sound by placing a letter tile above each colored tile while saying the phoneme.

Use Touch & Say to read rash - /r/ /ə/ /sh/, rash.
Clear board.

WE DO: Build shot
Say "Now, let's build the real word shot together, as in, "I had to get a flu shot at the doctor's office today." Repeat shot."
Stretch the phonemes - /sh/ /ɒ/ t/, shot.
Place one colored tile on the board for each phoneme in shot while saying the phonemes - /sh/ /ɒ/ t/.

Ask individual students the following questions to lead students in spelling each phoneme by placing letter tiles above the colored tiles, one at a time:

- "What is the first phoneme you hear?"
Answer: /sh/
- "What letters spell /sh/?"
Answer: sh

PRACTICE LINK FOR BLAST ONLINE: ExploreBlast.online

Sample page from Teacher Guide

Word Sort

Challenging ☆

	how many phonemes?	Digraph	Blend
1 stop	1 2 3 4		
2 cram	1 2 3 4		
3 drag	1 2 3 4		
4 rush	1 2 3 4		

More Challenging ☆☆☆

	how many phonemes?	Digraph	Blend
1 drum	1 2 3 4		
2 cash	1 2 3 4		
3 trap	1 2 3 4		
4 trash	1 2 3 4		

Most Challenging ☆☆☆

	how many phonemes?	Digraph	Blend
1 dress	1 2 3 4		
2 smash	1 2 3 4		
3 drip	1 2 3 4		
4 crash	1 2 3 4		

866.401.READ | ReallyGreatReading.com

Sample page from Student Workbook

QUICK FACTS

Whole class, daily supplemental instruction in 1st grade (prevention)

Small-group intervention in grades 2–5 for students who still struggle with phonics basics or older ELL or SPED students who struggle with letter-sound correspondence and the basic structure of English words

Improves high-frequency word knowledge, decoding, spelling, and fluency





Blast Foundations has 25 units, each with 5 daily lessons. Each lesson keeps students actively engaged in the learning process with multisensory teaching. Each daily lesson is designed to be completed in 15-30 minute sessions. In one week, students are immersed in 75-150 minutes of explicit foundational skills instruction.

1 LESSON 1 (MONDAY) Letter Sounds/High-Frequency Words

In the first lesson of the week, students focus on building up their fluency with letter sounds and high-frequency words. The target is automaticity. Concepts are taught and practiced in manner that helps students quickly recall what they have learned. Teachers have the flexibility to teach the words and letter sounds that their students still need to learn, rather than those that they have already mastered.

2 LESSON 2 (TUESDAY) Phonemic Awareness

The phonemic awareness components of Blast Foundations G1A starts with blending and segmenting single-syllable words, and then moves onto blending and segmenting multisyllabic words. These core skills are taught and practiced in a high-impact, engaging multi-sensory manner. The phonemic awareness instruction is pure; students concentrate on speech sounds without linking them to letters or spellings. There is high concentration on vowel phonemes which helps promote reading and spelling success.

3 LESSON 3 (WEDNESDAY) Phonics Instruction

The phonics lessons of Blast Foundations G1A build from simple concepts (letter-sound correspondence, CVC words, digraphs, blends) to progressively more

complex concepts of word structure (advanced vowel spellings, multi-syllabic words, inflectional endings). By Unit 14 of Blast Foundations G1A, students are reading multisyllabic words like *cactus*, *nutshell*, and *index*. By Unit 21, students are reading words like *nickname*, *escape*, and *seamless*. By the last unit, students are reading words like *rented*, *reaches*, and *coastline*.

4 LESSON 4 (THURSDAY) Student Practice

Each unit has a series of high-impact practice activities that focus on the phonics concepts taught. The practice is cumulative and controlled. Students only practice with the items that have been explicitly taught. These activities include Detective Work, Word Sorts, and Phrase and Sentence Reading. Each student reads aloud several times during each lesson so the teacher can provide immediate feedback through Positive Error Correction.

5 LESSON 5 (FRIDAY) Wrap-up

Each unit wraps up with a Show What You Know lesson. Students practice their letter sounds and high-frequency words and then read a series of phrases and sentences aloud. These activities allow teachers to see who has mastered the concepts and who needs more help. Lastly, students are asked to spell phonologically predictable words.



BLAST FOUNDATIONS™ SCOPE AND SEQUENCE

LESSON 1		LESSON 2	LESSON 3, 4, 5
Unit	Letter-Sound Fluency	Heart Word Fluency	Phonics Concept, Reading, and Spelling
1	<ul style="list-style-type: none"> • Introduction to <i>Blast Foundations</i> • Demonstrate the importance of reading accurately • Introduce <i>Blast Student Kits</i> and <i>Workbooks</i> 		<ul style="list-style-type: none"> • Introduction to <i>Blast Foundations</i> • Short and long vowel sounds and motions • Identification of short and long vowel sounds
2	<ul style="list-style-type: none"> • Consonant Letter Sounds m, t, & s • Teach <i>Look, Think, Say!</i> routine • Teach <i>Pop-Up</i> and <i>3-Up</i> games 		<ul style="list-style-type: none"> • Introduce <i>Build a Word</i> • Closed Syllables • Reading & Spelling Closed Syllable words with Short A & Short I • Introduce <i>Spell It!</i>
3	<ul style="list-style-type: none"> • Consonant Letter Sounds f, d, & r 	the, of, you, and, to	<ul style="list-style-type: none"> • Reading & Spelling Nonsense Words with Short A and Short I • Introduce <i>Detective Work</i> • Introduce <i>Phrases & Sentences to Read</i>
4	<ul style="list-style-type: none"> • Consonant Letter Sounds g, l, & h • Teach <i>Read a Row</i> game 	in, is, for, that, it	<ul style="list-style-type: none"> • Digraph sh • Reading & Spelling with Short A and Short I
5	<ul style="list-style-type: none"> • Consonant Letter Sounds b, n, & c 	he, was, his, on, are	<ul style="list-style-type: none"> • Reading & Spelling with Short U
6	<ul style="list-style-type: none"> • Consonant Letter Sounds k, w, & v 	as, with, this, they, if	<ul style="list-style-type: none"> • Digraph th
7	<ul style="list-style-type: none"> • Consonant Letter Sounds j, p, & y 	at, be, or, have, from	<ul style="list-style-type: none"> • Reading & Spelling with Short E
8	<ul style="list-style-type: none"> • Consonant Letter Sounds b, x, & z 	one, had, by, but, not	<ul style="list-style-type: none"> • Digraphs ch & wh
9	<ul style="list-style-type: none"> • Consonant Letter Sounds qu, y, & x 	what, all, were, we, when	<ul style="list-style-type: none"> • Digraph ck
10	<ul style="list-style-type: none"> • Trigraphs tch & dge 	your, can, said, there, down	<ul style="list-style-type: none"> • Trigraphs tch & dge
11	<ul style="list-style-type: none"> • Letter chunks al & all 	an, come, which, she, do	<ul style="list-style-type: none"> • Double Trouble Rule • Chunk all
12	<ul style="list-style-type: none"> • Graphemes ff, ll, & ss 	how, their, want, will, up	<ul style="list-style-type: none"> • Short vowel spelling rules: Double Trouble, Digraph ck, & Trigraphs tch & dge



BLAST FOUNDATIONS™ SCOPE AND SEQUENCE

LESSON 1		LESSON 2		LESSON 3, 4, 5	
Unit	Letter-Sound Fluency	Heart Word Fluency	Phonemic Awareness	Phonics Concept, Reading, and Spelling	
13	No new letter sounds	may, no, now, came, out	• 2-sound blends	• 2-sound blends	
14	No new letter sounds	many, these, then, so, some	• Teach <i>Whale Talk</i> • Teach <i>Syllable Stomp</i> • Teach segmenting syllables	• Reading two-syllable words with Closed Syllables	
15	No new letter sounds	them, her, would, make, like	• Review <i>Whale Talk</i> • Review <i>Syllable Stomp</i> • Teach blending syllables	• Spelling two-syllable words with Closed Syllables	
16	No new letter sounds	him, into, put, has, look	• Review <i>Whale Talk</i> • Review <i>Syllable Stomp</i> • Review blending syllables	• Open Syllables in one-syllable words	
17	• Letter chunk ing	take, go, see, could, where	• R-Controlled Vowel /or/	• Reading two-syllable words with Open and Closed Syllables • Chunk ing	
18	• Flexibility in sounds (schwa)	any, about, old, here, saw	• R-Controlled Vowel /ar/	• Reading two-syllable words with schwa	
19	• Vowel-Consonant-e spellings	little, ask, over, long, very	• R-Controlled Vowel /er/	• Reading one-syllable words with Vowel-Consonant-e	
20	• Review of Vowel-Consonant-e spellings	good, around, know, too, every	• Cumulative review of R-Controlled Vowels	• Reading two-syllable words with Vowel-Consonant-e	
21	• Long E Vowel Teams ee & ea • Long A Vowel Teams ai & ay • y spells Long E	pretty, away, after, think, going	• Other Vowel / /	• Reading one- and two-syllable words with Long E and Long A Vowel Teams ee , ea , ai , & ay • y spells Long E	
22	• Long I Vowel Spelling igh • Long O Vowel Team oa	walk, before, again, who, been	• Other Vowel /oi/	• Reading one- and two-syllable words with Long I Spelling igh & Long O Vowel Team oa	
23	• 3 Sounds of Suffix -ed	goes, always, because, own, only	• Other Vowel /ou/	• 3 Sounds of Suffix-ed	
24	• Inflectional endings -er , -ed , -s , -es , & -ing	give, our, both, does, write	• Other Vowel / /	• Reading words with inflectional endings	
25	• Cumulative review & celebration		• Cumulative review of Other Vowels	• Cumulative review & celebration	



COMPONENTS OF BLAST FOUNDATIONS™

TEACHER LESSON PLAN BOOK SET **BLASTILP \$225.00**



- Includes a thorough explanation of the concepts, routines, and procedures
- Provides guidance on how to adjust instruction to match the age and maturity level of the student
- Can be taught by a wide range of educators, not just seasoned literacy professionals
- Provides incremental professional development
- Can be used with both Primary and Elementary student workbooks
- Includes: 2 lesson plan books, set of vowel posters, set of 2 student workbooks

STUDENT WORKBOOK SET **BLASTIPRSW/BLASTIELSW \$19.00**



- Contains all the printed material a student needs to participate
- Helps students develop mastery and automaticity with key skills
- Two levels of workbooks to choose from:
 - PRSW (Primary Student Workbook: Grades K-1)
 - ELSW (Elementary Student Workbook: Grades 2 and beyond)

BLAST ONLINE **BLASTOL \$95/year \$59/6 months**

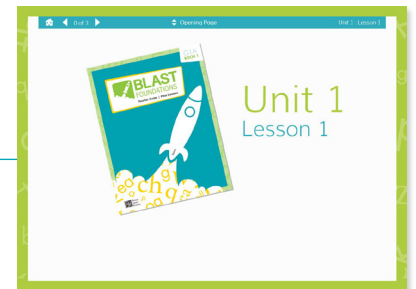

- Reduces teacher prep time
- Can be used with an interactive whiteboard, LCD projector, tablet, or stand-alone computer
- Helps students learn and retain concepts faster and more effectively

BLAST FOUNDATIONS STUDENT KIT **BLASTKIT \$52.00**



- Magnetic color tiles, letter tiles, and SyllaBoards™ are used to ensure students have a clear understanding of how English words are constructed
- Multisensory aspect helps students learn concepts faster and retain them better
- Includes all the physical manipulatives needed to complete the 25 units





Really Great Reading®
Specialists in Reading Education

P.O. Box 46, Cabin John, MD 20818-0046

Toll Free 866-401-READ (7323) • Fax 240-465-0478

info@reallygreatreading.com • www.ReallyGreatReading.com