

B60W

CONJOINT CONTROL OF VEHICLE SUB-UNITS OF DIFFERENT TYPE OR DIFFERENT FUNCTION; CONTROL SYSTEMS SPECIALLY ADAPTED FOR HYBRID VEHICLES; ROAD VEHICLE DRIVE CONTROL SYSTEMS FOR PURPOSES NOT RELATED TO THE CONTROL OF A PARTICULAR SUB-UNIT

Definition statement

This place covers:

Control systems for conjoint control of vehicle sub-units of different type or different function.

Control systems specially adapted for hybrid vehicles. Purposes of road vehicle drive control systems for purposes that are

- not related to control of any particular sub-unit, i.e. the controlled sub-unit is not specified, or
- related to conjoint control of vehicle sub-units of different type or different function.

Estimation or calculation of driving parameters for road vehicle drive systems that are used for purposes

- not related to a particular sub-unit, i.e. the controlled sub-unit is not specified, or
- for conjoint control of vehicle sub-units of different type or different function.

Details of control systems for road vehicle drive control, e.g. monitoring of signals for controllers that are used for purposes

- not related to a particular sub-unit, i.e. the controlled sub-unit is not specified, or
- for conjoint control of vehicle sub-units of different type or different function.

Control systems specially adapted for autonomous road vehicles (AV).

Philosophy of conjoint control in subclass [B60W](#):

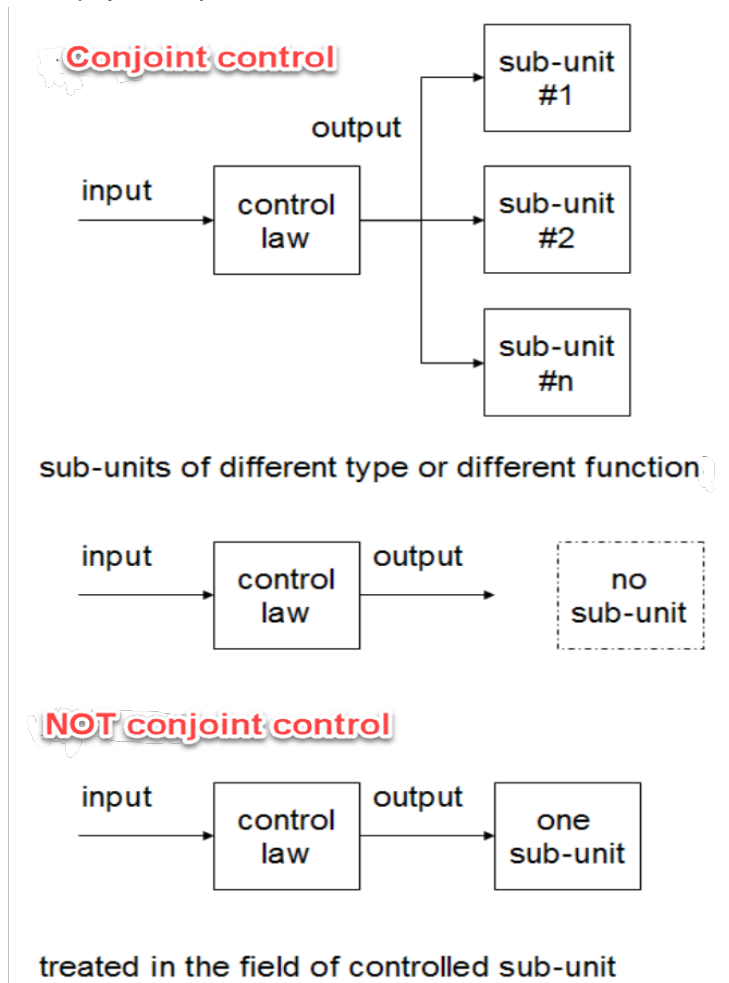

Relationships with other classification places

[B60W](#) is the application-oriented place covering vehicle drive control systems in general that are not related to a particular sub-unit or used for conjoint control of two or more sub-units. The control of a single particular sub-unit, or same type multiple sub-units for the same purpose are not covered by this subclass and have to be classified in the relevant class for the sub-unit, e.g. [F02D](#) or [F16H](#). Where a single particular sub-unit is controlled by signal or commands from other sub-units, the control of this single sub-unit is classified in the relevant place for this sub-unit. For example the control of variable ratio gearing by means of signals from the engine or accelerator is classified in the subclass for gearing [F16H](#).

Conjoint control of driveline units, e.g. engines, and variable-ratio gearing occurring only transiently during ratio shift and being also characterized by the control of the gearing is also classified in the subclass for gearing [F16H](#).

One main group ([B60W 20/00](#)) is intended for all control systems specially adapted for hybrid vehicles. This group also covers control systems specially adapted for hybrid vehicles that do not reveal any use of conjoint control. The arrangement or mounting of plural diverse prime-movers for common propulsion of a hybrid vehicle will be classified in the subclass [B60K](#). Conjoint control of pure electric drive units like motor and battery will be classified in subclass [B60L](#). When the architecture or type of transmission of the hybrid vehicle is also of interest, it should be classified in the relevant groups of main group [B60K 6/00](#).

This subclass also cover road vehicle drive control systems not related to any particular sub-unit, i.e. which do not specify which sub-unit is activated or actuated by the control system. For example a

Relationships with other classification places

control system or control method for predicting a collision which is not related to the control of any specific sub-unit will be correctly covered by the appropriate group [B60W 30/08](#).

Detecting means in general (e.g. ultrasonic radar, TV camera, image processing, or measuring means) are covered by the classes [G01](#), [G06](#) or [H04](#) and their appropriate subclasses.

References

Limiting references

This place does not cover:

Propulsion of purely electrically-propelled vehicles with power supplied within the vehicle	B60L 50/00 - B60L 58/00
---	---

Informative references

Attention is drawn to the following places, which may be of interest for search:

Arrangement or mounting of plural diverse prime-movers for mutual or common propulsion, e.g. hybrid propulsion systems comprising electrical and internal combustion motors	B60K 6/00
Vehicle fittings for automatically controlling vehicle speed by acting on a single sub-unit	B60K 31/00
Electrical circuits for triggering safety arrangements to protect or prevent injuries to occupants or pedestrians	B60R 21/01
Brake control systems for vehicle drive stability	B60T 8/1755
Controlling combustion engines, such controlling being peculiar to the devices driven thereby, the devices being other than parts or accessories essential to engine operation, e.g. controlling of engines by signals external thereto	F02D 29/00
Combinations of clutches and brakes	F16D 67/00
Control functions within change-speed- or reversing-gearings for conveying rotary motion	F16H 61/00
Systems for controlling position, course, altitude, or attitude of land, water, air, or space vehicles	G05D 1/00
Traffic control systems i.e. systems transmitting information to a plurality of vehicles simultaneously in order to co-ordinate the flow of vehicles or systems controlling platoons of vehicles	G08G 1/00
Anti-collision systems	G08G 1/16

Special rules of classification

Whenever one or more specific types of sub-units are controlled, classification in main group [B60W 10/00](#) should be given for each of the different sub-units controlled. For each controlled sub-unit a classification symbol should be added in the relevant place. When documents classified in main group [B60W 10/00](#) are also relevant for main groups [B60W 20/00](#) - [B60W 60/00](#), a classification in one of these groups is required.

Contrary to the IPC, [B60W](#) in CPC is a multi-aspect classification system where classifications have to be given for all features of the independent claims and for all features contributing to the operability of the disclosed invention.

The use of the indexing codes is mandatory.

Glossary of terms

In this place, the following terms or expressions are used with the meaning indicated:

Automatic control	Control system for mechanising or assisting, to a full- or partial extent, tasks associated with driving of the vehicle, e.g. those normally carried out by the driver or those necessary to control the motion of the vehicle.
Auxiliary equipment	Subsidiary or supplementary device of the propulsion, transmission or other units of the vehicle, e.g. a pump for supply of pressure for the control unit.
Conjoint Control	Programmed or condition-responsive automatic controller on-board the vehicle, embodying control logic for plural vehicle sub-units and sends control signals to actuators of two or more vehicle sub-units, so that the sub-units act together to solve a particular problem, in order to improve stability, comfort or safety by managing the global dynamics of the vehicle, or in response to a particular driving condition. The control logic considers the plural vehicle sub-units simultaneously, however, the control signals need not be sent at the same time.
Conjoint control of diverse vehicle sub-units	Control of different sub-units within the same vehicle for those vehicles defined under note to class B60, and of general applicability to different types of vehicles normally under the control of a human driver or autonomous driving system.
Cruise control	System for automatically controlling vehicle speed, which may include additional functions e.g. control of distance between vehicles, so-called "Adaptive Cruise Control" (ACC).
Drive control system	Electronic system in a road vehicle for automatically controlling the movement of that vehicle in order to take certain actions.
Driveline Clutch	Clutch used for purposes other than changing gear ratios.
Driving parameter	All input or output parameters of the road vehicle drive control systems, e.g. road specific parameters, driver or passenger related parameters, state variables of motion of the vehicle body or parameters related to the vehicle itself like load or weight of the vehicle.
Hybrid vehicle	Vehicles having two or more prime movers of more than one type, e.g. electrical and internal combustion motors, and that are either singularly or in combination used for propulsion of the vehicle.
Road Vehicle	Motorised passenger vehicle for transportation on roads, e.g. an automobile, truck or bus
Sub-Unit	One of the following vehicle systems: propulsion system, clutch system, torque converters, change-speed gearing system, system for distributing drive torque between front and rear axles, axle differential system, brake system, steering system, suspension system, energy storage means, fuel cells or auxiliary equipment.

B60W 10/00

Conjoint control of vehicle sub-units of different type or different function (for propulsion of purely electrically-propelled vehicles with power supplied within the vehicle [B60L 50/00](#) - [B60L 58/00](#))

Definition statement

This place covers:

Sub-units of different type or function, which are controlled by a controller on board of the vehicle. The controller sends control signals to two or more vehicle sub-units, so that the sub-units act together to solve a particular problem in order to improve stability, comfort or safety of the vehicle or to propel the vehicle. For each of the sub-units which are controlled by the controller a classification symbol (invention-type) should be added.

References

Limiting references

This place does not cover:

Propulsion of purely electrically-propelled vehicles with electric power supplied within the vehicle	B60L 50/00 – B60L 58/00
--	---

Special rules of classification

When classifying in group [B60W 10/00](#), classification must also be made in groups [B60W 20/00](#) - [B60W 60/00](#) in order to identify the purpose or use of the control. For each of the sub-units which are controlled by the controller a classification symbol (invention-type) should be added. The sub-units covered by [B60W 10/00](#) have to be sub-units of a vehicle as defined by [B60W 20/00](#) - [B60W 60/00](#).

The use of the indexing codes is mandatory.

B60W 10/198

with exhaust brakes

Definition statement

This place covers:

Exhaust brake systems provided in addition to the engine.

References

Informative references

Attention is drawn to the following places, which may be of interest for search:

Including control of combustion engines	B60W 10/06
---	----------------------------

B60W 20/00

Control systems specially adapted for hybrid vehicles {(hybrid vehicle design, [B60K 6/00](#); electric vehicles [B60L](#))}

Definition statement

This place covers:

Control systems exclusively for hybrid vehicles, i.e. vehicles combining at least two different prime movers which convert energy taken from at least two different in vehicle storage devices, e.g. fuel tank and battery, into mechanical energy for the propulsion of the vehicle.

References

Limiting references

This place does not cover:

Hybrid vehicle design	B60K 6/00
Electric vehicles	B60L

Special rules of classification

Whenever one or more specific types of sub-units are controlled, classification in main group [B60W 10/00](#) should be given for each of the different sub-units controlled. When the architecture or type of transmission of the hybrid vehicle is of interest, it should be classified in the relevant groups of [B60K 6/00](#).

B60W 20/10

Controlling the power contribution of each of the prime movers to meet required power demand

Definition statement

This place covers:

Conjoint control of the prime movers to meet power demand including also situations in which the power is not demanded for propelling the vehicle, to keep one prime mover in an off-state or an on-state, e.g. engine is kept on for warming up with high battery charge state or engine is kept off even with low battery charge state in a traffic jam.

B60W 20/11

using model predictive control [MPC] strategies, i.e. control methods based on models predicting performance {(utilising navigation and traffic information in the control strategy [B60W 20/12](#))}

Definition statement

This place covers:

Control strategies using performance models of prime movers and sub-units, e.g. battery or gearing, are predicted and adjusted to be controlled at their optimal working points; Control is based on internal vehicle information only;

Control strategies to operate the vehicle or one or more sub-units at the point of highest energy efficiency with MPC providing the data for selecting optimal points of operation to meet the required power demand.

References

Limiting references

This place does not cover:

Control strategies based on data provided by conventional technology, e.g. optimum fuel consumption line	B60W 20/10
Utilising navigation and traffic information in the control strategy	B60W 20/12

Special rules of classification

If the particular effect is fuel economy, no additional classification is necessary. If it is another effect, additional classification in [B60W 20/15](#) is necessary.

Glossary of terms

In this place, the following terms or expressions are used with the meaning indicated:

MPC	Model Predictive Control; Control relying on one or more models of the drive train or vehicle sub-units, wherein the presently applied control signal is based on an optimal control signal computed over a future period of time. For example, the current status of the vehicle, e.g. vehicle dynamics or weight, torque at drive wheels, the driver input, e.g. accelerator pedal position, steering and the status of various sub-units, e.g. engine speed, motor torque, gear ratio engaged, clutch position or torque, temperature, battery charge state. These data are fed into the models. Based on this information, MPC simulates possible changes to the sub-units, e.g. changing engine speed or gear ratio, switching from series hybrid to parallel hybrid. The models may deliver several results. These results are analysed to determine the most suitable sub-unit status in order to arrive at a particular effect.
-----	---

B60W 20/12

using control strategies taking into account route information {(estimation or calculation of non-directly measurable driving parameters [B60W 40/00](#))}

Definition statement

This place covers:

Control systems using path-dependent information, e.g. road slope, curve radius, distance to intersection, traffic information, weather conditions, emission or noise restrictions;

The sub-units are brought into the most suitable status depending on this information, e.g. keeping the engine switched off and propelling the vehicle using only the motor if there is a traffic jam.

References

Limiting references

This place does not cover:

Estimation or calculation of [non-directly measurable] driving parameters	B60W 40/00
---	----------------------------

B60W 20/13

in order to stay within battery power input or output limits; in order to prevent overcharging or battery depletion

Definition statement

This place covers:

Control strategies aiming at maintaining battery state of charge (SOC) within defined limits to extend battery lifetime.

References

Informative references

Attention is drawn to the following places, which may be of interest for search:

Control methods based on models predicting performance	B60W 20/11
--	----------------------------

B60W 20/14

in conjunction with braking regeneration

Definition statement

This place covers:

Control systems only usable for hybrid vehicles controlling power contribution of prime movers to keep battery healthy in combination with braking regeneration.

References

Limiting references

This place does not cover:

Braking regeneration	B60L 7/10
----------------------	---------------------------

Special rules of classification

Mandatory classification in Braking Regeneration: [B60W 30/18127](#)

B60W 20/15

Control strategies specially adapted for achieving a particular effect

Definition statement

This place covers:

Control strategies directed to performance or operation of the vehicle in such a way so as to provide a specific benefit, e.g. maintaining lubrication of an engine.

B60W 20/16

for reducing engine exhaust emissions

Definition statement

This place covers:

Control strategies lowering the level of emissions leaving the exhaust, i.e. downstream of catalytic converter or particle filter, not the emissions leaving the engine.

B60W 20/17

for noise reduction

Definition statement

This place covers:

Control strategies mitigating vehicle noise, e.g. for driver comfort, quiet running in noise abatement areas.

B60W 20/18

for avoiding ageing of fuel

Definition statement

This place covers:

Control strategies related to extended engine off times, e.g. preventing the fuel from getting old, cylinder purging, lubrication issues.

B60W 20/19

for achieving enhanced acceleration

Definition statement

This place covers:

Control strategies to provide enhanced acceleration, e.g. the electrical motor assists the engine for better acceleration.

B60W 20/20

Control strategies involving selection of hybrid configuration, e.g. selection between series or parallel configuration

Definition statement

This place covers:

Control systems deciding which hybrid configuration is used for vehicles with a drive train architecture which allows for different configurations, e.g. parallel, serial.

References

Limiting references

This place does not cover:

Architecture of the hybrid electric vehicle	B60K 6/442
---	----------------------------

B60W 20/30

Control strategies involving selection of transmission gear ratio {(control of change speed gearings, together with other vehicle sub-units [B60W 10/10](#); HEV transmission gearing [B60K 6/36](#); gearings and control thereof [F16H](#))}

Definition statement

This place covers:

Control systems deciding selection of transmission gear ratio, e.g. with a limited number of available gear ratios for electric drive mode or with a different number of available gear ratios in electric mode and in internal combustion mode.

References

Limiting references

This place does not cover:

Control of change speed gearings, together with other vehicle sub-units	B60W 10/10
HEV transmission gearing	B60K 6/36
Gearings and control of gearings	F16H

Special rules of classification

Control systems deciding selection of gear ratio and prime mover power distribution should receive classification [B60W 20/10](#).

Synonyms and Keywords

In patent documents, the following words/expressions are often used as synonyms:

- "transmission", "gearbox" and "gearing"

B60W 20/40

Controlling the engagement or disengagement of prime movers, e.g. for transition between prime movers {(power-up or power-down of the driveline [B60W 30/192](#))}

Definition statement

This place covers:

Control systems for enabling smooth transition between motor and engine propulsion, e.g. during hill hold, during synchronisation processes, during transition between electrical and combined drive mode.

References

Limiting references

This place does not cover:

Power-up or power down of the driveline	B60W 30/192
---	-----------------------------

B60W 20/50

Control strategies for responding to system failures, e.g. for fault diagnosis, failsafe operation or limp mode

Definition statement

This place covers:

Control strategies evaluating or monitoring of an operational condition of the vehicle to identify any potential failure, or operation of the vehicle with minimum or no harm to the vehicle in the event of failure, e.g. driving the vehicle to a reasonable distance without necessarily damaging the engine, electrical drive mode when fuel tank is empty.

B60W 30/00

Purposes of road vehicle drive control systems not related to the control of a particular sub-unit, e.g. of systems using conjoint control of vehicle sub-units {, or advanced driver assistance systems for ensuring comfort, stability and safety or drive control systems for propelling or retarding the vehicle (anti-lock brake systems [ABS] [B60T 8/00](#))}

Definition statement

This place covers:

Advanced Driver Assistance Systems for ensuring comfort, stability and safety or purposes of road vehicle drive control systems for propelling or retarding the vehicle

Relationships with other classification places

Control of a single sub-unit or of sub-units of the same type or function is classified in the relevant place for the sub-unit.

References

Informative references

Attention is drawn to the following places, which may be of interest for search:

Braking, in particular anti-lock braking systems	B60T
--	----------------------

B60W 30/02

Control of vehicle driving stability

Definition statement

This place covers:

- Control of vehicle driving stability when claimed in general and not related to a specific sub-unit.
- Control of vehicle driving stability using conjoint control of more than one sub-unit, e.g. propulsion unit, brake system and steering.

References

Limiting references

This place does not cover:

Exclusive brake control systems for vehicle drive stability	B60T 8/1755
---	-----------------------------

Informative references

Attention is drawn to the following places, which may be of interest for search:

Suspension control characterised by the regulation being combined with other vehicle control systems	B60G 17/0195
--	------------------------------

B60W 30/045**Improving turning performance****Definition statement**

This place covers:

Systems influencing the drivability or agility of a vehicle in a curve

References**Informative references**

Attention is drawn to the following places, which may be of interest for search:

Arrangements for automatically controlling steering depending on driving conditions sensed and responded to	B62D 6/00
---	---------------------------

B60W 30/06**Automatic manoeuvring for parking (controlling only the steering
[B62D 15/0285](#))****References****Informative references**

Attention is drawn to the following places, which may be of interest for search:

Steering aids	B62D 15/02
Parking performed automatically	B62D 15/0285

B60W 30/08**{Active safety systems} predicting or avoiding probable or impending collision
{or attempting to minimise its consequences}****Definition statement**

This place covers:

Control systems for predicting coming or possible collisions or taking measures to prevent or weaken the impact of a collision.

References**Limiting references**

This place does not cover:

Electrical circuits for triggering safety arrangements to protect or prevent injuries to occupants or pedestrians	B60R 21/01
---	----------------------------

Means for detecting collisions, impeding collision or roll-over	B60R 21/013
---	-----------------------------

Informative references

Attention is drawn to the following places, which may be of interest for search:

Anti-collision systems for land vehicles	G08G 1/16
--	---------------------------

B60W 30/14

{Adaptive} cruise control

Definition statement

This place covers:

Control systems for adapting vehicle speed to particular conditions, e.g. for controlling distance to preceding vehicle or taking actions when preceding vehicles is going to stop.

References

Informative references

Attention is drawn to the following places, which may be of interest for search:

Vehicle fittings for automatically controlling vehicle speed by acting on a single sub-unit	B60K 31/00
Traffic control systems i.e. systems transmitting information to a plurality of vehicles simultaneously in order to co-ordinate the flow of vehicles or systems controlling platoons of vehicles	G08G 1/00

B60W 30/18

Propelling the vehicle

Definition statement

This place covers:

Control systems for the driving or retarding of road vehicles controlling multiple sub-units

References

Informative references

Attention is drawn to the following places, which may be of interest for search:

Control systems specially adapted for hybrid vehicles	B60W 20/00
Controlling combustion engines, such controlling being peculiar to the devices driven thereby, the devices being other than parts or accessories essential to engine operation, e.g. controlling of engines by signals external thereto	F02D 29/00
Control functions within change-speed- or reversing-gearings for conveying rotary motion	F16H 61/00

B60W 40/00

Estimation or calculation of {non-directly measurable} driving parameters for road vehicle drive control systems not related to the control of a particular sub unit, {e.g. by using mathematical models}

Definition statement

This place covers:

The estimation or calculation of non-direct measurable parameters related to vehicle drive control and not used for a particular sub-unit, e.g. by using mathematic models for estimation of the parameters.

Special rules of classification

This group does not cover direct measurement of parameters related to vehicle drive control using a particular sensor. Parameter acquisition relying on sensors should be classified in the area of the sensor, e.g. cameras [G06K](#), ultrasonic [G01S](#).

B60W 50/00

Details of control systems for road vehicle drive control not related to the control of a particular sub-unit {, e.g. process diagnostic or vehicle driver interfaces}

Definition statement

This place covers:

- Process diagnostic or vehicle driver interfaces,
- Failure detection models,
- Failure correction strategy,
- Monitoring means for the function of the control systems,
- Interaction between the driver and the control system.

Special rules of classification

This group does not cover detection of failures of or in single sub-units. Such detection is classified in the relevant place for the sub-unit.

Glossary of terms

In this place, the following terms or expressions are used with the meaning indicated:

Interaction between the driver and the control system	Communications or actions with a feedback loop between the driver and the control system
---	--

B60W 50/02

Ensuring safety in case of control system failures, e.g. by diagnosing, circumventing or fixing failures

Definition statement

This place covers:

On board failure detection

Failure correction strategies

Means or methods to repair failures

Work around methods in case of failure

Control input devices for limp home

B60W 50/029

Adapting to failures or work around with other constraints, e.g. circumvention by avoiding use of failed parts

Definition statement

This place covers:

Control methods for fail safe which will avoid situations where a defect part is involved, i.e. the control uses different parts or a method for a work around. No redundant parts are used and these methods could lead to constraints in functionality.

B60W 50/035

Bringing the control units into a predefined state, e.g. giving priority to particular actuators

Definition statement

This place covers:

Control methods for fail safe which will put the control in a predefined state, e.g. the transmission in particular gear ratio, or for giving priority to a particular actuator.

B60W 50/08

Interaction between the driver and the control system

Definition statement

This place covers:

Interfaces between driver and control system not for a single or particular sub-unit with interaction, e.g. communications or actions with a feedback loop between the driver and the control system. The interaction can be a tactile feedback to the driver, e.g. vibrations of the steering wheel.

B60W 50/10

Interpretation of driver requests or demands

Definition statement

This place covers:

- Interpreting driver intention and initiating control based on different parameters, e.g. vehicle speed and driver activity
- By monitoring actuating speed of the accelerator

B60W 50/12

Limiting control by the driver depending on vehicle state, e.g. interlocking means for the control input for preventing unsafe operation

Definition statement

This place covers:

Preventing particular driving manoeuvres based on the vehicle situation, e.g. limiting driver control by drive assistance systems in critical driving situations

B60W 50/14

Means for informing the driver, warning the driver or prompting a driver intervention

Definition statement

This place covers:

- Warning or informing the driver when the movement of the vehicle will be changed momentarily, e.g. adding a slight yaw rate, momentary deceleration
- Informing the driver that the drive control mode will change, e.g. from comfort mode to performance mode
- Assistance systems for warning the driver, e.g. warning the driver if approaching speed at a stopping location will be too high

B60W 60/00

Drive control systems specially adapted for autonomous road vehicles

Definition statement

This place covers:

- On-board control systems for autonomous road vehicles operating on a road network, whereby the control systems perform decision making processes in real-time about all dynamic driving tasks necessary to control the position of the vehicle along the road network, based on factors related to the vehicle itself, its occupants or its environment, and actuate the required vehicle subsystems to execute the dynamic driving tasks. An example of a decision making process is to adjust the immediate trajectory of the autonomous vehicle based on the environmental conditions in a close surrounding of the vehicle, while traveling along a given route provided by a navigation system. Although the ultimate driving decision remains on board, the AV may outsource part of its computation tasks (e.g. for managing computation load, updating machine learning models).
- Control systems for hand-over processes to and from vehicle occupants specially adapted therefor.

Relationships with other classification places

This group covers on-board control systems, whereas subclass [G05D](#) covers remote control systems.

This group also covers control systems for autonomous vehicles in an open road environment.

Traffic control systems are covered by [G08G](#).

References

Informative references

Attention is drawn to the following places, which may be of interest for search:

Arrangement or adaptations of instruments	B60K 35/00
Route guidance in navigation systems	G01C 21/34
Radio direction-finding; Radio navigation; Determining distance or velocity by use of radio waves; Locating or presence-detecting by use of the reflection or reradiation of radio waves; Analogous arrangements using other waves	G01S
Systems controlling the positions of autonomous vehicles driving in a coordinated manner, e.g. in convoys or fleets	G05D 1/00
Control of position of land vehicles in two dimensions, in general	G05D 1/02
Electric digital data processing	G06F
Pattern recognition	G06K
Computer systems based on specific computational models	G06N
Image data processing or generation, in general	G06T
Traffic control systems for road vehicles	G08G 1/00

Special rules of classification

When classifying in group [B60W 60/00](#), multi-aspect classification must also be applied in groups [B60W 10/00](#) – [B60W 50/00](#), whenever appropriate.

The use of the indexing codes of this subclass is mandatory.

Glossary of terms

In this place, the following terms or expressions are used with the meaning indicated:

Route	series of road segments in a road network, between a starting point and a destination
Trajectory	path travelled over ground

B60W 60/001

{Planning or execution of driving tasks}

Definition statement

This place covers:

The planning or execution of the following dynamic driving tasks:

- Acceleration or deceleration
- Braking
- Steering

B60W 60/0013**{specially adapted for occupant comfort}****Definition statement***This place covers:*

Planning and execution of driving tasks adapted to the comfort of the occupants, e.g. by limiting acceleration, centrifugal or centripetal forces or jerk.

B60W 60/0015**{specially adapted for safety}****Definition statement***This place covers:*

Planning and execution of driving tasks prioritizing safety, e.g. increased spacing, reduced speed.

References**Informative references**

Attention is drawn to the following places, which may be of interest for search:

Active safety systems predicting or avoiding probable or impending collision or attempting to minimise its consequences	B60W 30/08
---	----------------------------

B60W 60/0018**{by employing degraded modes, e.g. reducing speed, in response to suboptimal conditions}****Definition statement***This place covers:*

Limitation of autonomous vehicle operations in response to vehicle systems failure, extreme weather conditions or infrastructure conditions.

B60W 60/00188**{related to detected security violation of control systems, e.g. hacking of moving vehicle}****Definition statement***This place covers:*

The operation of the autonomous vehicle is adapted or restricted in response to a detected security violation.

References**Informative references**

Attention is drawn to the following places, which may be of interest for search:

Means for preventing jamming or interference of a remote switch control signal	B60R 25/2072
--	------------------------------

Wireless connected vehicles in generals	H04W 4/40
Security arrangements, e.g. access security or fraud detection; Authentication, e.g. verifying user identity or authorisation	H04W 12/00
Fraud detection or prevention Detection of security violation	H04W 12/12

B60W 60/0025

{specially adapted for specific operations}

References

Informative references

Attention is drawn to the following places, which may be of interest for search:

Dispatching vehicles on the basis of a location, e.g. taxi dispatching	G08G 1/202
--	----------------------------

B60W 60/00253

{Taxi operations}

Definition statement

This place covers:

The "taxi operations" include the carriage of passengers for reward, e.g. buses. Taxi operations also include "ridesharing".

References

Informative references

Attention is drawn to the following places, which may be of interest for search:

Rendez-vous, i.e. searching a destination where several users can meet, and the routes to this destination for these users; Ride sharing, i.e. searching a route such that at least two users can share a vehicle for at least part of the route	G01C 21/3438
--	------------------------------

B60W 60/0027

{using trajectory prediction for other traffic participants}

References

Informative references

Attention is drawn to the following places, which may be of interest for search:

Target tracking using radar, ultrasonic or lidar systems	G01S 13/66 , G01S 15/66 , G01S 17/66
Radar, ultrasonic or lidar systems specially adapted for anti-collision purposes	G01S 13/931 , G01S 15/931 , G01S 17/931
Analysis of motion per image analysis per se	G06T 7/20

Informative references

Analysis of motion per image analysis, with motion prediction involving stochastic approaches, e.g. Kalman filters	G06T 7/277
Depth or shape recovery from motion	G06T 7/579
Determining a region of interest in an image for recognising patterns in scene	G06V 10/25
Extraction of features in an image for object recognition	G06V 10/40
Recognising patterns in scenes exterior to a vehicle, e.g. recognising other vehicles, pedestrians, traffic signs, parking places	G06V 20/56

B60W 60/005**{Handover processes (between vehicles and remote control entities
[G05D 1/0011](#))}****Definition statement**

This place covers:

Decision making processes used to initiate or abort handover of control of the driving tasks between the on-board control system and an occupant, e.g. ascertaining occupant or control system ability to perform driving tasks, determining time or distance required to perform handover.

Processes performed during handover of control of the driving tasks between the on-board control system and an occupant, e.g. processes for gradually transferring the driving tasks from the on-board control system to an occupant.

References**Limiting references**

This place does not cover:

Handover processes between vehicles and remote control entities	G05D 1/0011
---	-----------------------------

Informative references

Attention is drawn to the following places, which may be of interest for search:

Interaction between the driver and the control system	B60W 50/08
Selecting or switching between different modes of propelling	B60W 50/082

Special rules of classification

When classifying in [B60W 60/0051](#) - [B60W 60/0061](#), processes used to initiate or abort handover are classified in the relevant subgroups of [B60W 60/0051](#) - [B60W 60/0061](#) and processes performed during handover are classified in [B60W 60/0051](#) - [B60W 60/0053](#).

B60W 2556/40**High definition maps****Definition statement**

This place covers:

The use of precise infrastructure information provided by the on-board vehicle navigation system or by an external system.

References

Informative references

Attention is drawn to the following places, which may be of interest for search:

Traffic control systems	G08G
-------------------------	----------------------