

Natural Sciences Grade 8

By:
Siyavula Uploaders

Natural Sciences Grade 8

By:
Siyavula Uploaders

Online:
< <http://cnx.org/content/col11050/1.1/> >

CONNECTIONS

Rice University, Houston, Texas

This selection and arrangement of content as a collection is copyrighted by Siyavula Uploaders. It is licensed under the Creative Commons Attribution 3.0 license (<http://creativecommons.org/licenses/by/3.0/>).

Collection structure revised: September 12, 2009

PDF generated: October 28, 2012

For copyright and attribution information for the modules contained in this collection, see p. 140.

Table of Contents

1 Term 1	
1.1	Energy to begin 1
1.2	Present energy sources 3
1.3	Hydroelectricity 5
1.4	Nuclear power 7
1.5	Future energy sources 10
1.6	Electricity 12
1.7	Electric Circuits 15
1.8	Vocabulary for electricity 21
1.9	Units of electricity 24
1.10	Heat and temperature 28
1.11	Reflection and refraction of light 32
1.12	Refraction of white light 42
2 Term 2	
2.1	What is everything 47
2.2	Building blocks of matter 48
2.3	Phase changes of matter 50
2.4	Crystals and solutions 54
2.5	Atoms 57
2.6	Molecules 59
2.7	Elements and compounds 61
2.8	Metals and non-metals 75
2.9	Compounds and mixtures 77
2.10	Separation of mixtures 79
3 Term 3	
3.1	Prehistoric life 83
3.2	Fossils 84
3.3	Life on earth 89
3.4	Survival: habitat 93
3.5	Animals are adapted 97
3.6	Plant adaptations 101
3.7	Sustainability 105
3.8	Sustainable activities 107
3.9	World population 109
4 Term 4	
4.1	The ecosystem 111
4.2	Different ecosystems 115
4.3	The role of plants in an ecosystem 119
4.4	Ecological relationships 122
4.5	Special food relationships 125
4.6	Ecotourism 128
4.7	Role of water 130
4.8	Ecological problems 135
Attributions 140

Chapter 1

Term 1

1.1 Energy to begin¹

1.1.1 NATURAL SCIENCES GRADE 8

1.1.2 ENERGY: ELECTRICITY, HEAT AND LIGHT

1.1.3 Module 1: Energy to begin

Energy is derived mainly from the sun and is available to us in various forms.

Some facts concerning energy:

- Energy is the **capacity for doing work**. We measure energy in **joule (J)**.
- There are **two main types of energy**:
- The energy of action or motion is known as **KINETIC energy**
- The energy of position is known as **POTENTIAL energy**
- Energy also occurs in **various forms**, e.g.:

Chemical energy, which is obtained from chemical substances like petroleum, oil, gas, batteries and food-stuffs;

Electrical energy, which is derived from electricity;

Sound energy, from loudspeakers

Radiant energy, from light and heat. The sun is our largest source of radiant energy.

Nuclear energy, is stored in the nucleus of the atom.

Energy cannot be created or destroyed. It can only be converted from one form to another.

1.1.4 ACTIVITY:

1.1.5 To identify the different types of energy

1.1.6 [LO 2.1, LO 2.2, LO 2.4]

Assignment

In the following list, indicate the form of energy that is present:

1. Car battery
2. Paraffin stove
3. Wind-up toy car

¹This content is available online at <<http://cnx.org/content/m19990/1.1/>>.

4. Hair drier
5. Rubber band (shooting)
6. Radio
7. Food
8. A growing plant
9. Burning candle
10. Nuclear power station

Assessment of forms of Energy

Were you able to indicate the forms of energy correctly?

[LO 2.2]

1.1.7 Assessment

LO 2: Constructing Science Knowledge:

The learner will know and be able to interpret and apply scientific, technological and environmental knowledge.

This is evident when the learner:

- recalls meaningful information;
- categorises information;

2.4 applies knowledge.

1.1.8 Memorandum

Assignment:

1. Car battery – CHEMICAL to ELECTRICAL
2. Paraffin stove - CHEMICAL TO HEAT
3. Wind-up toy car – POTENTIAL TO KINETIC
4. Hair dryer – ELECTRICAL TO HEAT
5. Elastic band (being shot) - POTENTIAL TO KINETIC
6. Radio – ELECTRICAL TO SOUND
7. Food – CHEMICAL TO KINETIC
8. A growing plant – RADIANT TO KINETIC
9. Burning candle – CHEMICAL TO LIGHT AND HEAT
10. Nuclear power station – KINETIC TO ELECTRICAL

- Explain this to grade 8 with the help of a simple example.
- It is generally known that the common light bulb provides us with light, but also becomes so hot that it can hardly be touched after a few moments. Approximately 100J of electric energy are converted to light energy AND heat energy within one second. The light energy has the value of about 5J, while the heat equals about 95J.
- The conversion therefore is as follows:
 - ELECTRIC ENERGY TO LIGHT ENERGY AND HEAT ENERGY
 - A light bulb therefore is altogether uneconomical!
- If you consider this, you will realise that the food provides the **SOURCE OF ENERGY** of human beings, but electricity and fuels provide all other aspects of energy. This brings us to the next learning unit.

1.2 Present energy sources²

1.2.1 NATURAL SCIENCES

1.2.2 GRADE 8

1.2.3 ENERGY: ELECTRICITY, HEAT AND LIGHT

1.2.4 Module 2

1.2.5 Present Energy Sources

- At present, most of our energy is derived from fossil sources (coal, oil, natural gas with secondary products e.g. liquid petroleum) and nuclear sources. Fossil sources are not renewable and are becoming fewer. Utilising them also causes pollution. Although we may find it difficult to imagine a world without electricity, this energy source is not available in many parts of South Africa and the African continent.
- In South Africa, energy is provided in different forms, the most important being electricity and liquid fuels (refined from crude oil and coal), coal and biomass (firewood).

The main sources of energy for generating electricity in South Africa are:

burning of coal;
hydroelectricity;
nuclear power.

1.2.6 Coal-burning and power stations

1.2.6.1 ACTIVITY:

1.2.6.2 To understand and evaluate coal burning as a a source of energy

1.2.6.3 [LO 2.3, LO 2.4]

At present, coal is the most generally used source of energy, to produce electricity, as South Africa has vast coal reserves. ESKOM coal power stations produce roughly 90% of the country's electricity. We have 18 of these large power stations.

Assignment 1:

Visit the Eskom website to find more information about this type of power generation.

What you mainly need is information on the basic operation of a typical power station.

What does the acronym ESKOM stand for?

To whom is the electricity supplied?

Assignment 2:

Complete the following table to represent the power-generating process by placing the different steps of this process in the correct order.

Turbine turns the rotors of the generator.

Coal is burnt.

Steam drives the turbines.

Electricity is carried away through copper wires.

Coal is ground finely.

Water in pipes is heated to provide steam.

The rotor is an electromagnet that generates electricity.

Coal is mined and transported.

²This content is available online at <<http://cnx.org/content/m19991/1.1/>>.

1.	-----
2.	-----
3.	-----
4.	-----
5.	-----
6.	-----
7.	-----
8.	-----

Table 1.1

Assignment 3:

Answer the following questions, making use of the information you have gained concerning the process.

1. What eventually happens to the steam that drives the turbines?
2. How much water is needed to operate this system for a day?
3. Name one place in South Africa where you can see high cooling towers.
4. Name any other waste that is formed during the generation of electricity.
5. Is burning coal for the generation of electricity regarded as “clean” with regard to nature?

Assessment of the steps that are followed in the process of generating electricity:

Were you able to place the steps in the correct order and answer the questions correctly?

[LO 2.3; LO 2.4]

1.2.7 Assessment

LO 2: Constructing Science Knowledge:

The learner will know and be able to interpret and apply scientific, technological and environmental knowledge.

This is evident when the learner:

- categorises information;
- interprets information;

2.4 applies knowledge.

1.2.8 Memorandum

PRESENT ENERGY SOURCES

- In **South Africa** the main sources of energy used to generate electricity are:
 - Burning of coal
 - Hydroelectricity
 - Nuclear power

COAL-BURNING AND POWER STATIONS

Assignment 1

- At present, this is the most generally used source of energy, and therefore of electricity, as South Africa is blessed with vast coal reserves. The ESKOM coal power stations produce roughly 90% of the country’s electricity. We have 18 of these large power stations.

ESKOM — ELECTRICITY SUPPLY COMMISSION

- This organisation provides 95% of South Africa and more than half of Africa with electricity.

In brief, a coal-firing power station operates as follows:

Assignment 2

	Coal is mined and transported
	Coal is ground
	Coal is burned
	Water in pipes is heated to provide steam
	Steam drives the turbines
	Turbines turn the rotor of the generator
	The rotor is an electromagnet that generates electricity
	Electricity is carried away by means of copper wires

Table 1.2

Assignment 3:

The steam that turns the turbines has to escape somewhere - It has to be condensed through cooling, and this requires water!

Each power station requires approximately 150 million litres of water per day. Most of this is lost through evaporation!

Typical cooling towers can be seen along the N2 just outside Cape Town and elsewhere in South Africa.

Waste that is formed during the process comprises harmful gases like sulphur dioxide, carbon dioxide, and nitrogen dioxide – these can bind with moisture in the air and cause acid rain.

Burning coal to generate electricity cannot be seen as a "clean" method and is harmful to nature because of the resultant air pollution, acid rain and particles of ash pumped into the air.

1.3 Hydroelectricity³

1.3.1 NATURAL SCIENCES

1.3.2 Grade 8

1.3.3 Energy: Electricity, heat and light

1.3.4 Module 3

1.3.5 Hydroelectricity

1.3.5.1 Activity:

1.3.5.2 To understand and evaluate electricity as a source of energy

1.3.5.3 [LO 1.1, LO 1.2, LO 1.3]

We live in a very dry country, but we do have two large permanently flowing rivers and ESKOM has erected two large hydroelectric power stations. One is situated close to the Gariiep Dam in the Free State and the other is at the Van der Kloof Dam near Petrusville.

³This content is available online at <<http://cnx.org/content/m19992/1.1/>>.

Assignment 1:

Find out where these two large dams (and any other large dams), are situated and draw a map of South Africa to indicate their positions.

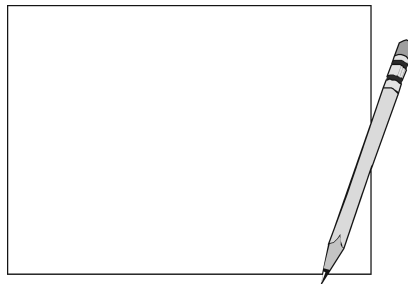

Figure 1.1

Assessment of location of Dams

Were you able to identify the dams correctly?

Hydroelectricity can basically be explained in brief by means of the following points:

- The downward movement of water, due to gravitational pull, energises the molecules of water.
- The falling water turns a turbine and converts the energy of the molecules to electric energy.
- The transfer of energy to some or other turning mechanism has been in use for more than 2 000 years.

Assignment 2:

Read and find out more: Visit the Internet and use a search engine, using words like “aqueduct” and “water wheel”.

The water wheel

Aqueducts

Give feedback to the class.

1.3.5.4 ACTIVITY:**1.3.5.5 To compare and evaluate hydroelectricity and coal burning as sources of energy [LO 2.2, LO 2.3]**

Assignment 1:

Complete the following table dealing with **coal-burning power stations** as opposed to **hydroelectric power stations** with regard to the following headings: Decide whether you are dealing with an advantage or disadvantage in each instance and mark the corresponding column.

Aspect	Coal power		Hydroelectricity	
	Advantage	Disadvantage	Advantage	Disadvantage
Pollution				
Cost				
Job-creation				
Reserves				
Speed of process				
Reliability of source				

Table 1.3

Conclusion:

1.3.6 Assessment

LO 1: Scientific investigations:

The learner will be able to act confidently on curiosity about natural phenomena, and to investigate relationships and solve problems in scientific, technological and environmental contexts.

This is evident when the learner:

- plans investigations;
- conducts investigations and collects data;
- evaluates data and communicates findings.

LO 2: Constructing Science Knowledge:

The learner will know and be able to interpret and apply scientific, technological and environmental knowledge.

This is evident when the learner:

- categorises information;
- interprets information;

1.4 Nuclear power⁴

1.4.1 NATURAL SCIENCES

1.4.2 Grade 8

1.4.3 Energy: Electricity, heat and light

1.4.4 Module 4

1.4.5 Nuclear power

1.4.5.1 ACTIVITY:

1.4.5.2 To investigate the generation of nuclear power as a source of energy

1.4.5.3 [LO 1.2, LO 1.3, LO 3.1]

Assignment 1:

⁴This content is available online at <<http://cnx.org/content/m19994/1.1/>>.

Do a project on “Nuclear power in South Africa”

Divide into groups for collecting information on nuclear power. Each group will answer the questions that follow and provide feedback in the form of a poster.

Where is South Africa’s nuclear power station?

How much electricity is provided by this power station?

To whom is this electricity provided?

Which dangerous metal is used in the power-generating process?

Why is cooling an important component of this power-generating process?

Is it true that you need to burn 25 railway truckloads of coal to obtain the same amount of energy that is provided by a piece of uranium the size of one golf ball?

Visit:

www.eskom.co.za/nuclear.overview

Assessment of Information Gathering

Were you able to gather adequate information to answer the questions and provide feedback through the poster?

[LO 1.2; LO 1.3]

Assignment 2:

Have a class discussion on whether nuclear power has value or not.

Assessment of Class Discussion

Were you able to identify values?

[LO 3.1]

1.4.6 Assessment

LO 1: Scientific investigations:

The learner will be able to act confidently on curiosity about natural phenomena, and to investigate relationships and solve problems in scientific, technological and environmental contexts.

This is evident when the learner:

- plans investigations;
- conducts investigations and collects data;
- evaluates data and communicates findings.

LO 3: Science, Society and the Environment

The learner will be able to demonstrate an understanding of the interrelationships between science and technology, society and the environment.

This is evident when the learner:

3.1 understands science as a human endeavour.

1.4.7 Memorandum

Assignment 1:

- Do a project on “Nuclear power in South Africa”
- The learners have to be divided into groups for collecting information on nuclear power. Each group is to address the questions that follow:
- Where is South Africa’s nuclear power station? AT DUINEFONTEIN NEAR MELKBOS
- How much electricity is provided by this power station? 6% + TO OTHER COUNTRIES
- Which dangerous metal is used for the power-generating process? ENRICHED URANIUM
- Why is cooling an important component of this power-generating process? BECAUSE OF THE IMMENSE HEAT THAT IS GENERATED

- Is it true that you can burn 25 railway truckloads of coal to obtain a quantity of energy equal to that which is provided by an amount of uranium that is equal to the size of one golf ball?
- YES
- Visit:
 - www.eskom.co.za/nuclear.overview
 - Many people become quite concerned when they think of nuclear power because of the horror of the Second World War and Hiroshima, etc.
 - The South African nuclear reactor is located north of Cape Town at Koeberg. It supplies roughly 6,5% of the country's electricity.
 - The Koeberg power station is the only nuclear power station on the African continent. It has a pressure water reactor with two units, each of which develops 960 MW of power. This represents approximately six percent of the power of that is developed in South Africa.
 - Koeberg supplies electricity to the whole of the Western Cape and exports surplus capacity to other parts of South Africa and to Namibia, our neighbour, during the summer.
 - Although is the only nuclear power station in Africa, there are 438 nuclear power installations right across the world. Most of these, namely 118, are in Northern America and supply approximately twenty percent of America's electricity. In France, 76 percent of the total power development capacity come from nuclear power stations. More than seventeen countries depend on nuclear facilities to provide at least a quarter of their total electricity requirement.
 - In spite of the perception that the use of nuclear power is being reduced, there are definite plans to extend the use of nuclear power in China, India, the Korean Republic and Japan. Six nuclear power installations were linked to electricity networks in 2000, and building was commenced on three new nuclear reactors – one in China and two in Japan. This has brought the number of nuclear reactors that are being built to 31.

A typical reactor comprises:

- Fuel – Uranium (U).
- A moderator – which slows down processes – almost like a system of brakes.
- Control rods – to stop a reaction.
- Cooling agent – which is able to cool down enormous heat.
- Protective covering to protect people from radioactive radiation – much concrete is frequently required in this regard.

The process is as follows:

- Enriched uranium is split (fission) under controlled conditions.
- Splitting of one atom of uranium provides 10 million times the amount of energy that is obtained from burning one atom of carbon!
- The nuclear reaction releases an enormous amount of heat.
- The heat converts to steam.
- The steam drives a turbine, which, in turn, drives a generator.
- The steam is condensed and pumped back to cool down for reuse.

A more detailed explanation of the process:

- The enriched uranium has the form of small particles coated with layers of carbon and silicon carbide. These layers create an inhibitor.
- The fuel comes in the form of balls, each containing 15 000 of these enclosed uranium particles. The reactor contains 440 000 balls, 310 000 of which are fuel balls.

- The heat that is generated during the nuclear reaction is borne away by means of helium gas, which enters the reactor at about 500°C, moves across the reactor fuel and leaves the reactor at about 900°C. This hot gas is directed through the closed-circuit gas turbine that drives a generator. From the turbine, the gas returns to the reactor and the cycle starts all over again.

1.5 Future energy sources⁵

1.5.1 NATURAL SCIENCES

1.5.2 GRADE 8

1.5.3 ENERGY: ELECTRICITY, HEAT AND LIGHT

1.5.4 Module 5

1.5.5 Future Energy Sources

- Now that we have completed the previous learning unit, it is clear that we shall have to investigate alternative sources for our country's energy and electricity supply.
- The sources that we are referring to are known as RENEWABLE ENERGY SOURCES, and a fair amount of information on these sources is available.
- Renewable energy sources refer to: **SOLAR POWER**: Solar panels that can run heating systems installed on the roofs of houses, solar cells in calculators and in some cars, as well as solar ovens are examples of this. **WIND POWER**: Large vanes mounted on towers catch the wind and drive turbines to generate electricity.

1.5.5.1 ACTIVITY

1.5.5.2 To investigate the value of solar and wind power as renewable sources of energy

1.5.5.3 [LO 1.1, LO 1.2, LO 1.3]

Assignment 1:

Work in pairs and design a brochure to advertise one of the renewable energy sources. Focus on:

- your motivation for promoting this type of source, i.e. the advantages;
- a diagram to briefly and simply illustrate the operation of this method bearing in mind that you are trying to explain this to ordinary people;
- how this type of energy source benefits or harms the environment;
- problems one would experience with the use of this source – consider financial aspects;
- your personal opinion and motivation for consumers to consider it!

Each group should make a presentation and the class could select the best brochures.

Assessment of Brochure

Were you able to gather adequate information for assembling the brochure?

Discuss the value of renewable energy sources in the class. Can the human race continue to ignore these sources?

Assessment of Discussion on Renewable Energy Sources

Were you able to recognise the value of energy sources and realise that some traditional sources are not sustainable?

[LO 3.2]

⁵This content is available online at <<http://cnx.org/content/m19998/1.1/>>.

1.5.5.4 ACTIVITY

1.5.5.5 To investigate other types of renewable energy sources [LO 1.2, LO 2.3]

Some renewable energy sources are already in use and should be considered by those who plan for the future.

These include:

Tidal energy: the rising and falling of the tides between high and low tide is utilised.

Wave energy: is used in countries like Japan, Great Britain and Norway

Bio-gas: rubbish dumps and animal manure release large amounts of methane gas that can be exploited.

Geothermal energy: hot water springs

Assignment 1:

See whether you are able to find more information through the Internet.

Would SA be able to use any of the above renewable energy sources? Discuss this in class.

Assessment of Information on Renewable Energy Sources

Were you able to find further information about energy sources and to pass it on to the class?

[LO 1.2; LO 1.3]

1.5.6 Assessment

LO 1: Scientific investigations:

The learner will be able to act confidently on curiosity about natural phenomena, and to investigate relationships and solve problems in scientific, technological and environmental contexts.

This is evident when the learner:

- plans investigations;
- conducts investigations and collects data;
- evaluates data and communicates findings.

LO 2: Constructing Science Knowledge:

The learner will know and be able to interpret and apply scientific, technological and environmental knowledge.

This is evident when the learner:

- recalls meaningful information;
- categorises information;
- interprets information;

2.4 applies knowledge.

LO 3: Science, Society and the Environment

The learner will be able to demonstrate an understanding of the interrelationships between science and technology, society and the environment.

This is evident when the learner:

3.2 understands sustainable use of the earth's resources.

1.5.7 Memorandum

FUTURE ENERGY SOURCES

Activity

Assignment 1:

- Open memo

ALTERNATIVE ENERGY SOURCES

Activity:

Assignment 1:

- Potential new sources of energy include biomass, geothermal energy, hydroelectricity, thermal oceanic energy, wind energy and the direct conversion of sunlight to energy by means of photovoltaic cells (SOLAR CELLS).

Biomass

- Electricity can be generated by burning organic waste to heat water to form steam. Biomass includes wood, leaves, harvest residue and even animal waste products. These materials are converted into liquid fuels like ethanol, which is added to petrol, or methane gas, which can be applied in the same way as natural gas. The most popular use of biomass is simply burning it as a fuel, for instance as wood in a fireplace. This is a good option in South Africa.
- Hydroelectricity and wind are as attractive as options as the direct conversion of sunlight, as neither causes pollution and have no resultant chemical or radioactive waste either. It is a pity that our country has such a short supply of water.

Thermal oceanic energy

- Thermal oceanic energy converters are machines that are designed to generate energy in warm tropical seas. They utilise arm water at the surface for the evaporation of a liquid, like ammonia, which boils at very low temperatures.
- The steam that is produced through evaporation is forced through turbines to generate electricity. Then this gas is stored in tanks where it is converted into a liquid again by being cooled with cold water brought from the ocean. This process is repeated in a closed circuit. Our problem is that South Africa is not situated in the tropics.

Solar power

- The direct conversion of sunlight is the most promising of the renewable systems. Solar panels are only used on a small scale at present, but further development of this technology will probably lead to solar energy becoming one of the most important alternative energy technologies.
- This holds much promise for our country.

1.6 Electricity⁶

1.6.1 NATURAL SCIENCES

1.6.2 GRADE 8

1.6.3 ENERGY: ELECTRICITY, HEAT AND LIGHT

1.6.4 Module 4

1.6.5 Electricity

One of the forms of energy mentioned above is **ELECTRICITY**.

Electricity is an invisible form of energy that is related to the movement of very small particles. To understand this, one needs to understand the structure of an atom.

- An atom is the smallest particle that any substance consists of. It comprises a nucleus of particles known as **protons** (positive) and **neutrons** (neutral), as well as a surrounding cloud of negative particles – **electrons**. The electrons move in an electric circuit.
- In a neutral atom, the positive and negative particles are in balance.

⁶This content is available online at <<http://cnx.org/content/m20014/1.1/>>.

1.6.5.1 ACTIVITY:**1.6.5.2 To make a drawing of the structure of an atom [LO 2.1, LO 2.3]**

Assignment 1:

Ask your educator to explain the typical structure of an atom to you and then draw your own representation of it.

Assessment of the Sketch of an Atom

Were you able to draw the atom clearly.

[LO 1.2; LO 1.3]

The positive and negative particles in a neutral atom are usually in balance.

1.6.5.3 ACTIVITY:**1.6.5.4 To understand the concept of potential difference****1.6.5.5 [LO 2.1, LO 2.3, LO 2.4]**

- When an imbalance occurs, the negative electrons are set in motion.
- Electricity can be conducted for great distances along wires. This energy can be converted to other forms of energy, like light, heat and movement by means of an appliance connected to the wires.
- The electrons are not able to move by themselves but are pushed by the electric transfer that occurs. This “pushing” is known as the **POTENTIAL DIFFERENCE (Pd)**.
- This potential difference is usually produced by a power station or a battery. Inside the wiring, electrons will jump from one atom to another, like wagons of a freight train bumping against each other when force is applied at one end – it causes an impact that is transferred all along the wiring.

Assignment 1: Questions:

What is potential difference?

Find out what direct current is. Where is it used?

Assessment of Potential Difference

Were you able to answer the questions correctly?

[LO 2.1; LO 2.4]

Did you know?

- There is a mild but similar electric current in the human body. It moves along the nerves in the form of pulses.
- The machine that is able to detect and record this current is an EEG, (an electroencephalograph).
- During an investigation with an electroencephalograph, electrodes with sensors are attached to the body.

1.6.6 Assessment

Learning outcomes(Los)

LO 1

Scientific Investigations

The learner will be able to act confidently on curiosity about natural phenomena, and to investigate relationships and solve problems in scientific, technological and environmental contexts.

Assessment Standards(Ass)

This is evident when the learner:

1.1 plans investigations;

1.2 conducts investigations and collects data;

1.3 evaluates data and communicates findings.

LO 2

Constructing Science Knowledge

The learner will know and be able to interpret and apply scientific, technological and environmental knowledge.

Assessment Standards(ASs)

This is evident when the learner:

2.1 recalls meaningful information;

2.2 categorises information;

2.3 interprets information;

2.4 applies knowledge.

1.6.7 Memorandum

Assignment 1:

One of the listed forms of energy is ELECTRICITY.

- Electricity is an invisible form of energy that is based on the movement of very small particles. To understand this, one needs to understand the structure of an atom.
- An atom represents the smallest particle that any substance consists of. It comprises a small nucleus of particles known as **protons** (positive) and **neutrons** (neutral), as well as a surrounding cloud of small negative particles – **electrons**. It is the electrons that move in the electric circuit.
- In a neutral atom, the positive and negative particles are usually in balance.
- When an imbalance is created, the negative electrons come into motion.^{n °}

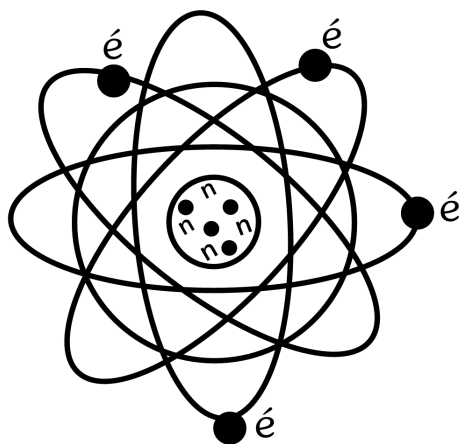

Figure 1.2

- Electricity is the movement of energy along long lengths of copper wire and this energy can be converted to other forms of energy such as light, warmth and movement by means of any appliance connected to it.
- The electrons cannot move by themselves; they are actually pushed forwards in the electric condition.

- This “pressure” is known as the **POTENTIAL DIFFERENCE (Pd)**.

éééé

The potential difference is usually produced by a power station or a battery.

- In the wiring, electrons will literally bounce from one atom to another like the wagons of a freight train that bump against one another when force is applied at one end – it causes an impact that is transferred all along the wiring.

Do you know?

- There is a mild but similar electric current in the human body, which moves along the nerves and muscles in the form of nerve and muscle pulses.
- The machine that is able to pick up and record this is an EEG, an electroencephalograph. During such an investigation, electrodes with sensors that take readings are attached to the body.
- Another application involves a pacemaker, which maintains the electrical impulses of the muscle tissue of the heart and supplements any inadequacy.

1.7 Electric Circuits⁷

1.7.1 NATURAL SCIENCES

1.7.2 Grade 8

1.7.3 Energy: Electicity, heat and light

1.7.4 Module 5

1.7.5 Electric circuits

An electric circuit consists of:

a source – cell (battery or cells)

conductors – wires

a switch – control point

other components like light bulbs, resistors and measuring instruments.

a Battery is a collection of cells.

1.7.5.1 ACTIVITY

1.7.5.2 To investigate the different components in a circuit and the symbols used to represent them [LO 2.3]

Assignment 1:

Draw a simple sketch of a single torch cell. One end has a protrusion, this is the positive pole. The opposite end is the negative pole. Add the labels “positive pole”, “negative pole”.

Now draw three more torch cells in a battery, as they would be placed in the shaft of a torch – what do you notice about the positive and negative poles.

This forms a battery and the cells are linked in series.

Assessment of Sketch

Were you able to draw the sketch and add labels correctly?

[LO 2.3]

⁷This content is available online at <<http://cnx.org/content/m20017/1.1/>>.

Drawing a number of components is time consuming and cumbersome. Using symbols saves time. These symbols are used internationally!

following symbols are used:

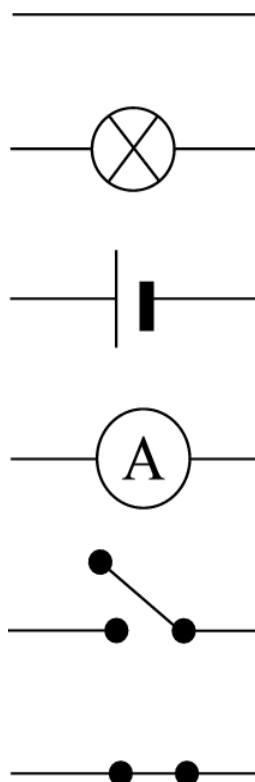

Figure 1.3

A length of copper wire is represented by means of a line

A light bulb is represented by means of:

A cell (the long thin line is the +)

An ammeter (to measure the strength of the current)

A switch : Open:

Closed:

A current diagram will always contain these components (parts). When we place all the components one after the other they are in series.

The diagram is always drawn in the form of a square. A simple circuit diagram will be drawn as follows.

Components can also be linked in parallel, as shown below.

Assignment 2:

Now draw three light bulbs that are linked in parallel – make use of symbols.

In a parallel linkage, the current is divided. If one of the light bulbs breaks the others will continue to glow!

The light bulbs in your home are mostly in _____.

Assessment of Sketch

Were you able to draw the sketch and add labels correctly?
[LO 2.4]

1.7.6 Assessment

LO 2: Constructing Science Knowledge:

The learner will know and be able to interpret and apply scientific, technological and environmental knowledge.

This is evident when the learner:

- interprets information;

1.7.7 Memorandum

Assignment 1:

An electric circuit comprises:

1. An electrical point and closed circuits.

2. A source – cell or battery

conductors – wires

a switch – controlling point

other components like light bulbs, resistors and measuring instruments.

cellbattery

Positive cellpool

A Battery is a collection of cells.

Drawing a number of components may be a nuisance and time-consuming. You need symbols that could provide shortcuts. Scientists have fortunately devised these already and they are used internationally!

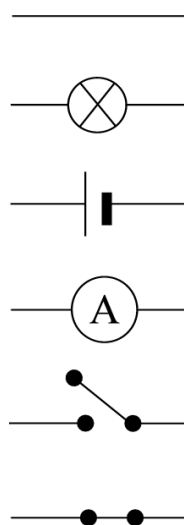

Figure 1.4

A length of copper wire is represented by means of a line

A light bulb is represented by means of:

A cell (the long thin line is the +)

An ammeter (to measure the strength of the current)

A switch

Assignment 2:

- A circuit diagram always contains these components (or parts) of the current.
- To begin, we arrange the components in line – this is known as "in series".
- The diagram is always drawn in the form of a square. A typical diagram is shown as:

A circuit diagram of three cells in series, an open switch, two light bulbs in series and an ammeter.

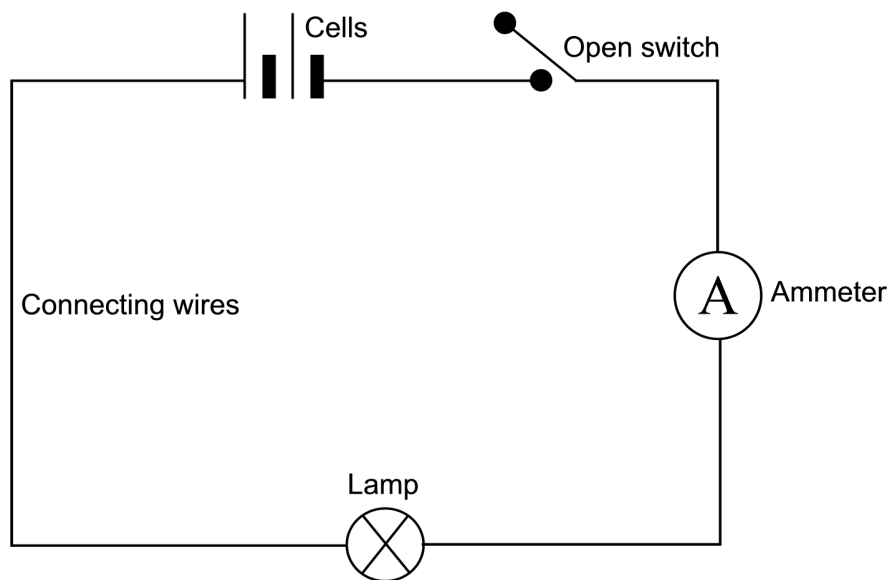

Figure 1.5

The concept of connection/linking in parallel may be difficult to understand. In the case of cells it can be shown as:

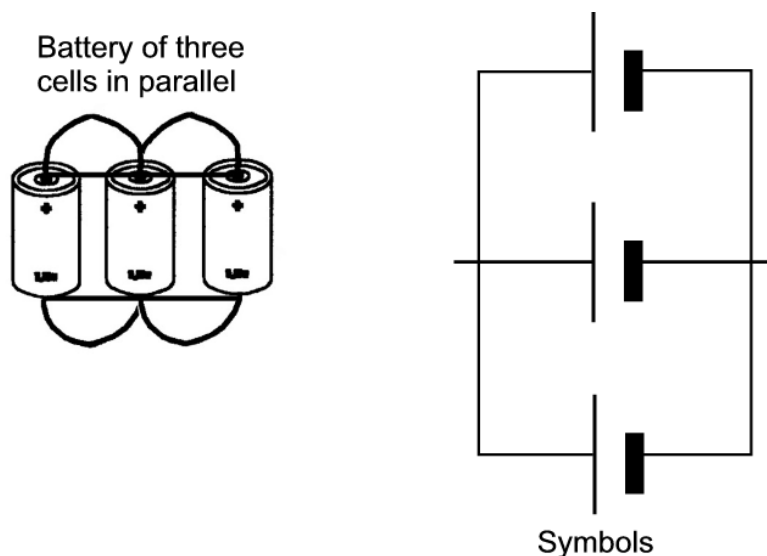

Figure 1.6

ELECTRICITY AND ITS USES IN THE HOME

THE LIGHT BULB:

- We'll begin with the light bulb. We have said that the light bulb represents ineffective utilisation of electric power. This is because 95 of the 100J are lost to heat and only 5J go towards light energy.
- We therefore need to think of a more economical means for lighting. But before we can investigate the issue further, we need to know what a typical light bulb consists of.
- The light bulb comprises a glass bulb filled with a particular gas, which isn't oxygen.
- The light bulb comprises a glass bulb filled with a particular gas, which isn't oxygen.

Why not? Wait and see. The wires inside a light bulb are wound up in small spirals. They are actually made of a particular metal filament (tungsten) that has resistance. This means that it tries to block the current and therefore becomes extremely hot. The heat is so intense that it begins to glow and becomes white hot! If the glass bulb were to be filled with oxygen, the intensity of the heat would melt everything. But the hollow is filled with a stable gas – Argon.

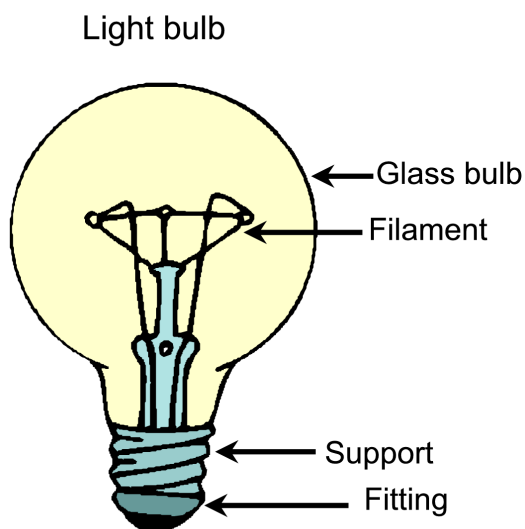

Figure 1.7

FLUORESCENT LIGHTS AND ECO-LAMPS:

Fluorescent lights (neon lights) are used in many offices and schools, as well as in some homes. They are filled with a particular gas and are lined with a chemical substance that emits light when an electric current passes through the tube. Fluorescent lights do not build up much heat, which reveals something of their effectiveness.

Eco-lamps: As we pay for our electricity, and also because electricity supply is limited, it is important for consumers to have electrical appliances that utilise electricity effectively. Fluorescent lights and eco-lamps do cost more, but they last much longer.



Figure 1.8

1.8 Vocabulary for electricity⁸

1.8.1 NATURAL SCIENCES

1.8.2 Grade 8

1.8.3 ENERGY: ELECTRICITY, HEAT AND LIGHT

1.8.4 Module 8

1.8.5 Vocabulary for Electricity

- There are words and terms that you will need to know before you study more about electricity.

TERM	SYMBOL	EXPLANATION
<u>Ampère</u>	A	The amount of current
Coulomb	C	The amount of electric charge that can be stored
Direct current	DC	A continuous electric current that flows in one direction only
Alternate current	AC	A continuous electric current that periodically reverses direction
Potential difference	PD	The difference between one side of the cell and the other side concerning electrons
Volt	V	Standard unit of measurement of electromotive force
Watt	W	Standard unit of electrical power
Ohm	Ω	An indication of the amount of resistance to the flow of electricity through a substance

Figure 1.9

Assignment 1:

Complete the following table:

⁸This content is available online at <<http://cnx.org/content/m31826/1.1/>>.

SYMBOL	TERM	EXPLANATION
Ω	
C		
A		
AC		
PD		

Figure 1.10

Assessment of Symbols

Were you able to identify the symbols correctly?

[LO 2.4]

The contributions made by scientists and inventors through the centuries have contributed greatly to our understanding of and the design of appliances that make our lives easier.

Assignment 2:

Find information about the following scientists and their work and make a poster to display your information in the class.

- Benjamin Franklin
- Nicola Tesla
- Alessandro Volta
- Georg Simon Ohm
- André Marie Ampère
- Charles Coulomb

You will notice that many of the terms that we use are derived from the name of the scientist who did the research.

Assessment of Poster on Scientists

Were you able to gather and communicate the information?

[LO 1.1; LO 1.2; LO 1.3]

Assessment of human Endeavour

Were you able to see the value of the work of the scientists?

[LO 2.4]

1.8.6 Assessment

LO 1: Scientific investigations:

The learner will be able to act confidently on curiosity about natural phenomena, and to investigate relationships and solve problems in scientific, technological and environmental contexts.

This is evident when the learner:

- plans investigations;
- conducts investigations and collects data;
- evaluates data and communicates findings.

LO 2: Constructing Science Knowledge:

The learner will know and be able to interpret and apply scientific, technological and environmental knowledge.

This is evident when the learner:

2.4 applies knowledge.

LO 3: Science, Society and the Environment

The learner will be able to demonstrate an understanding of the interrelationships between science and technology, society and the environment.

This is evident when the learner:

3.1 understands science as a human endeavour.

1.8.7 Memorandum

VOCABULARY FOR ELECTRICITY

Activity1

Assignment 1:

There is a list of words and terms that one needs to know before further studies in electricity can be undertaken

Term	Symbol	Explanation
Ampere	A	The amount of current that is used
Coulomb	C	The amount of electric charge that can be stored
Direct current	DC	A continuous electric current that flows in one direction only
Alternating current	AC	A continuous electric current that periodically reverses direction
Alternating current	AC	A continuous electric current that periodically reverses direction
Volt	V	Standard unit of measurement of electromotive force
Watt	W	Standard unit of electrical power

Figure 1.11

Assignment 2:

The contributions made by scientists through the centuries have contributed greatly to our concept of and to the design of machines that enhance our lives.

Among the important scientists that learners have to investigate, we have:

- **Benjamin Franklin**
- (1706-1790)
- 1752 - While flying a kite with a metal key during a thunderstorm, he observed sparks that indicated that lightning was charged with electricity.
- He initially thought that electricity was some magical liquid.

- Nicola Tesla:
- (1856-1943)
- He made the idea of alternating current acceptable and designed the Tesla coil, a transformer with an air core, used for producing high frequencies. It is used in radio technology.
- Alessandro Volta:
- (1745-1827)
- He discovered a method for separating two metals by means of electricity directed through chemical fluids in 1800. This produced the first electrical cells. He combined cells to produce the first battery.

- Georg Simon Ohm:
- He showed that all conductors offer resistance to an electric current.

- André Marie Ampère:
- (1775-1830)
- He discovered the electromagnetic effect, and developed the idea of the solenoid.

- Charles Coulomb:
- (1736-1806)
- He discovered the charges and forces that attract and repel in magnets.

1.9 Units of electricity⁹

1.9.1 NATURAL SCIENCES

1.9.2 Grade 8

1.9.3 ENERGY: ELECTRICITY, HEAT AND LIGHT

1.9.4 Module 9

1.9.5 Units of Electricity

1.9.5.1 ACTIVITY:

1.9.5.2 To calculate electricity costs [LO 1.3, LO 2.4]

- You may know that the unit in which electricity is sold is known as **kilowatt per hour – kW/hour**

⁹This content is available online at <<http://cnx.org/content/m20020/1.1/>>.

1 kWh is the amount of electric energy that an appliance with a power rating of 1 kW uses in one hour.

We use the following formula to calculate the kWh of any appliance:

$$\text{kWh} = \text{power} \times \text{time}$$

Say you want to know how much energy your hair drier (1 500 W = 1,5 kW) uses in 20 minutes (20 minutes = $\frac{1}{3}$ of an hour):

$$\text{kWh} = \text{power rating} \times \text{time}$$

$$= 1\,500\text{ W} \times 0,333$$

$$= 1,5\text{ kW} \times 0,333$$

$$= 0,5\text{ kWh}$$

You use the following formula to calculate the cost of the use of an electrical appliance:

$$\text{Cost} = \text{electrical energy in kWh} \times \text{cost of 1 kWh}$$

Supposing that 1 kWh costs 50c, the above hair drier will cost:

$$\text{Cost} = 0,5\text{ kWh} \times 50\text{c}$$

$$= 25\text{c}$$

$$= \text{R}0,25$$

Assignment 1:

Examine the pictures and calculate the cost of using each appliance. Electricity costs R2, 50 per kW.



Figure 1.12

Light bulb in use: 100 w for 5 hours



Figure 1.13

TV in use: 80W for 5 hours



Figure 1.14

Iron in use: 1500 W for 2 hours

Assessment of Calculations

Were you able to do the calculations correctly?

[LO 1.3; LO 2.4]

1.9.6 Assessment

LO 1: Scientific investigations:

The learner will be able to act confidently on curiosity about natural phenomena, and to investigate relationships and solve problems in scientific, technological and environmental contexts.

This is evident when the learner:

- evaluates data and communicates findings.

LO 2: Constructing Science Knowledge:

The learner will know and be able to interpret and apply scientific, technological and environmental knowledge.

This is evident when the learner:

2.4 applies knowledge.

1.9.7 Memorandum

Assignment 1

UNITS of ELECTRICITY

The amount of electricity that is used by an appliance depends on the type of appliance and the length of time for which it is used.

Appliances used for generating heat, like stoves (ovens), kettles, irons and hot water cylinders general use much more electricity and are more costly. Very powerful halogen light bulbs (spotlights) also consume much electricity, while appliances fitted with microchips or small motors, like electric toothbrushes and razors, will use less.

Each appliance bears an indication of its value - the **watt value**. This is the appliance's **power rating**. It is usually indicated on the outer cover of the appliance, like in the case of a light bulb. A 100-Watt light bulb will burn more brightly than a 60-Watt light bulb.

Watt actually indicates the amount of electricity per second that the appliance will use. As the watt unit is relatively small, we usually speak in terms of **kilowatt (kW)**

- 1 kW = 1000 W

A unit of electricity is read in terms of the amount of electricity that a 1 kW appliance will use in one hour or a 100 W appliance will use in 10 hours. This is the unit in which electricity is sold to consumers.

Your 100-W light bulb will therefore burn for 10 hours on 1 kW of electricity. Your father will be able to operate his electric drill (500W) for two hours only.

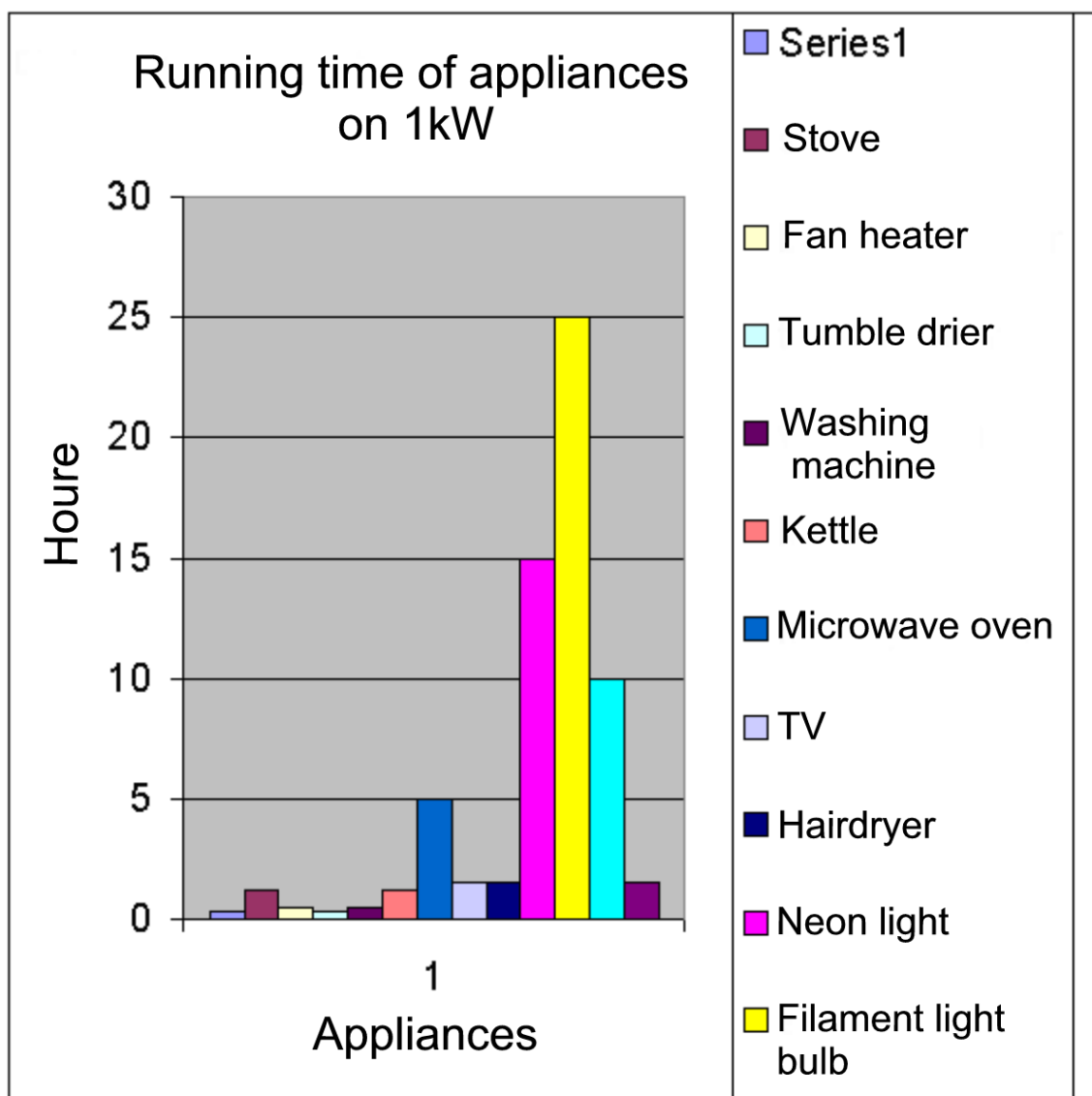

Figure 1.15

We know that electricity is sold units of **kilowatt per hour – kW/hour**

- 1 kWh is the amount of electrical energy that an appliance with a rating of 1 kW uses in one hour.

To determine the Wh rating of an appliance, we use the following formula:

- kWh = power rating x time

If you, for instance, want to know how much energy your hairdryer (1500W) uses in 20 minutes, you work it out like this:

- kWh = power rating x time
- 1 500w /1000w x 0.3
- = 0.45 kWh

The cost of using an electrical appliance can be determined by means of the following formula:

- Cost = electrical energy in kWh x cost of 1 kWh

Supposing that 1 kWh costs 50c, the use of your hairdryer (above) will cost:

- Cost = 0.45 kWh x 50c
- = R 2,25

1.10 Heat and temperature¹⁰

1.10.1 NATURAL SCIENCES

1.10.2 Grade 8

1.10.3 ENERGY: ELECTRICITY, HEAT AND LIGHT

1.10.4 Module 10

1.10.5 Heat and Temperature

Heat is a type of energy – the energy of the movement of particles. **Temperature** is the measure of how fast the molecules are moving

How do we measure temperature?

We use a **thermometer** that consists of a glass tube filled with a liquid such as mercury, which expands when it is warmed.

What is absolute zero?

The lowest temperature possible, at which it becomes impossible for molecules or atoms to move. This occurs at **-273,15 °C** or at 0 on the Kelvin scale. This low temperature was measured in a Finnish laboratory.

Find out what the **Kelvin scale** is.

You probably know that temperature can be measured on a Celsius scale or on a Fahrenheit scale. Temperatures used to be measured in Fahrenheit, so you may still find appliances that are marked in Fahrenheit, but most appliances nowadays use the Celsius scale.

How do you convert Fahrenheit to Celsius?

Subtract 32 and then divide by 9 and multiply by 5

F to C therefore is $(-32 \div 9 \times 5)$

For **Celsius to Fahrenheit** it is:

$\div 5 \times 9 + 32$

¹⁰This content is available online at <<http://cnx.org/content/m20027/1.1/>>.

1.10.5.1 ACTIVITY:**1.10.5.2 To understand temperature conversions [LO 2.4]**

Assignment 1:

Do you know the following?

1. The highest temperature ever recorded on earth is 720 million °F. It was recorded during nuclear fusion, in the USA.

What would this be in °C?

2. The highest air temperature has been measured in Libya, at 58 °C.

What is this in °F?

3. The lowest air temperature was recorded in Antarctica when the thermometer registered -190 °F.

What is this in °C?

Try: www.convert-me.com

Assessment of Temperature Conversions

Were you able to do the conversions?

[LO 2.4]

Heat Transfer

1.10.5.3 ACTIVITY:**1.10.5.4 To determine terms and concepts involved with the transfer of heat [LO 2.1, LO 2.3, LO 2.4]**

Assignment 1:

Complete:

There are different terms for describing the transfer of heat:

- CONVECTION

- CONDUCTION

- RADIATION

Assessment of Terms

Were you able to identify the terms?

[LO 2.4]

Heat and Water

Water has a remarkable capacity for retaining heat.

Much energy is needed for the temperature of water to increase or decrease by 1 °C.

Various factors influence heat retention by water:

- Water is a liquid.
- Water is transparent and light beams can penetrate to a depth of 20 m.
- A mass of water has waves and currents and vertical movement that can distribute heat.

If you compare the heat retention capacity of the land and the oceans, you will realise that there is a considerable difference.

Capacity for heat

We know that heat causes changes in temperature and that a unit of heat is measured in Joule as it is a type of energy.

Specific heat capacity is the amount of heat that is transferred (required or released) when the temperature of a substance changes by 1 °C or 1 K.

Water is the most expensive substance to heat because great amounts of heat are required to raise the temperature of water by a few degrees. Water, on the other hand, also provides large amounts of heat when it cools down.

The effect of this is most marked in the oceans, as they are large masses of water. They are warmed very slowly, but also retain the heat for a long time.

Assignment 2:

1. Explain why coastal towns have a moderate temperature in comparison with inland towns.
2. When does tea cool down faster? When you add cold milk and then leave it to cool or when you leave it to cool before adding cold milk? Explain.
3. Why does the water at the beach feel pleasantly warm when a cool day follows after several warm days?
4. Which factors play a part in the building up of heat capacity in water?

Assessment Explanations offered for Phenomena

Were you able to identify the symbols correctly? [LO 2.1; LO 2.3; LO 2.4]

Interesting applications of thermal principles have interesting results in the world around us.

Assignment 3:

Discuss each of the following:

Insulation of homes against heat.

Solar ovens.

Why the disk of a plough cooks food quickly.

Make your own solar cooking dish by shaping a sheet of cardboard to look like the disk of a plough and covering it with foil.

Position it at an angle that will ensure maximum sunlight, spear a sausage with a stick and hold it in position to see whether you can cook it with the use of solar power only!

1.10.6 Assessment

LO 2: Constructing Science Knowledge:

The learner will know and be able to interpret and apply scientific, technological and environmental knowledge.

This is evident when the learner:

- recalls meaningful information;

2.3 interprets information;

2.4 applies knowledge.

1.10.7 Memorandum

Activity1

Assignment 1:

HEAT AND TEMPERATURE

Heat is a type of energy – the energy of the movement of particles.

Temperature is the measure of how fast molecules move.

How is temperature measured?

- A **thermometer** is used. It is a glass tube that contains a fluid, e.g. mercury, which expands when it is warmed.

What is **absolute zero**?

- The lowest temperature possible, at which it becomes impossible for molecules or atoms to move. This occurs at **-273.15 °C** or at 0 on the Kelvin scale. This was measured in a Finnish laboratory.
- You probably know that temperature can be measured on a Celsius scale or on a Fahrenheit scale.
- Some appliances measure in Fahrenheit, while others measure in Celsius.

Celsius scale

- ON this scale, the lowest established point is freezing point, at 0 °C
- The highest established point is that of boiling water, i.e. steam, at 100 °C

Kelvin scale:

- For the Kelvin scale, zero is at absolute zero.
- $0\text{ K} = -273^{\circ}\text{C}$
- Add 273 to change from Kelvin to Celsius,
- Boiling water 100 °C is 373 K

How is Fahrenheit converted to Celsius?

- Subtract 32+, divide by 9 and multiply by 5
- F to C therefore is $(-32 \div 9 \times 5)$

Converting Celsius to Fahrenheit is done by:

- $F = C \div 5 \times 9 + 32$

TRANSFER OF HEAT

Activity

Assignment 1:

- **CONVECTION:** Movement of heat through air, e.g. air currents, e.g. fan heaters, warm winds.
- **CONDUCTION:** Distribution of heat through solid objects, e.g. warm rocks.
- **RADIATION:** Distribution of heat from heat-producing objects, e.g. the sun, a heater.

HEAT AND WATER

- Water has exceptional heat retention qualities.
- Much energy is required for the temperature of a mass of water to be increased or decreased by 1 °C.
- The relevant factors involve the following:
- Water is a liquid;
- Water is transparent and light beams can penetrate up to 20 m into water;
- Any mass of water has waves and currents and vertical motion that can distribute heat.
- If you compare the heat retention capacity of the land and the ocean, you will realise that there is a considerable difference.

THERMAL CAPACITY (HEAT CAPACITY)

Assignment 2:

We have mentioned that heat causes a change in the temperature and that the unit for measuring this heat is Joule, because it is a type of energy that is involved.

Specific thermal capacity is the amount of heat that is transferred (needed/released) when the temperature of a substance changes by 1 °C or 1 K.

- Water is the most expensive substance to heat because large amounts of heat are required to increase the temperature by a few degrees only.
- Water, on the other hand, yields large amounts of heat when it is cooled down.

- The effect of this is most evident over the oceans, which are large water masses.
- Water is heated very slowly, but retains heat for a long time.

Interesting applications of thermal principles result in the following phenomena around us:

- Discuss the following:
- Insulating houses against heat: houses lose 25 % of their heat through roofs and 25 % through the floor
- Solar ovens: a polystyrene cooker lined with foil provides a wonderful alternative for areas where there is no electricity
- Why the disk of a plough cooks food quickly

For the Learner

Make your own solar cooking dish by shaping a sheet of cardboard to look like the disk of a plough and covering it with foil.

Position it at an angle that will ensure maximum sunlight, spear a sausage with a stick and hold it in position to see whether you can warm it with the use of solar power only!

1.11 Reflection and refraction of light¹¹

1.11.1 NATURAL SCIENCES

1.11.2 Grade 8

1.11.3 ENERGY: ELECTRICITY, HEAT AND LIGHT

1.11.4 Module 11

1.11.5 Reflection and refraction of light

- **LIGHT** is another common type of energy.
- You parents or educators would like to have "eyes at the back of their heads" or would like you to believe that they see everything. We know that this is impossible, though, and for a simple reason.

1.11.5.1 ACTIVITY:

1.11.5.2 To determine the terms and concepts that relate to light

1.11.5.3 [LO 2.1, LO 2.3, LO 2.4]

1.11.5.3.1 Light travels along a straight line.

Light can change direction, though, and this happens in two ways:

- Refraction
- Reflection

REFLECTION: We are going to look at reflection as it occurs with **mirrors**.

When a beam of light arrives at a certain angle, it will be reflected at the same angle.

ANGLE OF INCIDENCE = ANGLE OF REFLECTION

¹¹This content is available online at <<http://cnx.org/content/m20029/1.1/>>.

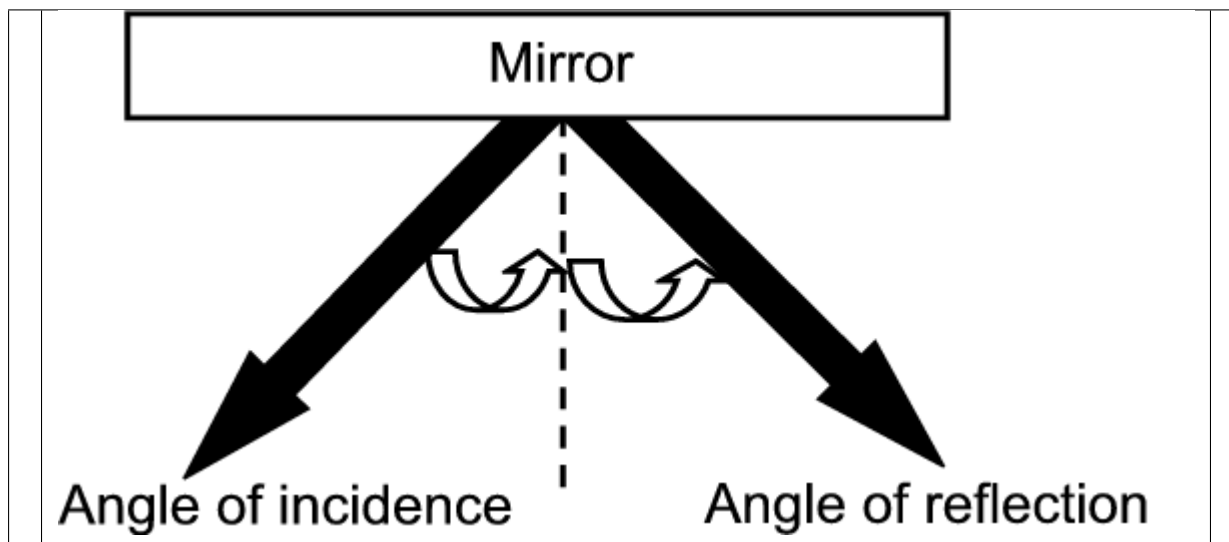

Table 1.4

1.11.5.4 ACTIVITY:

1.11.5.5 To establish concepts relating to reflection [LO 2.4]

Assignment 1:

1. Draw a sketch of a mirror, showing the angle of incidence and the angle of reflection. Use a protractor.

Assessment of the Sketch

Has the sketch been drawn correctly?

[LO 2.4]

Curved mirrors

Curved mirrors have many applications. They enlarge or diminish and distort the image. A curved mirror can be **CONCAVE**. This will **CONVERGE** light beams towards a fixed point, the **FOCUS**.

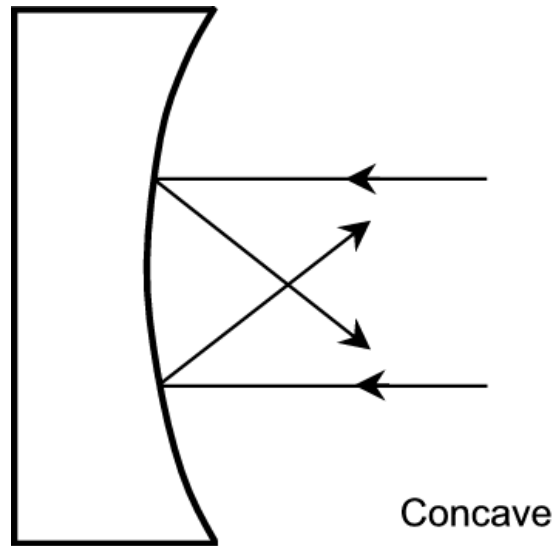

Figure 1.16

Other mirrors may be **CONVEX**. They will cause light beams to **DIVERGE** (spread apart). This scales down the image. An application of this is evident in the rear view mirror of a motor car or in wing mirrors.

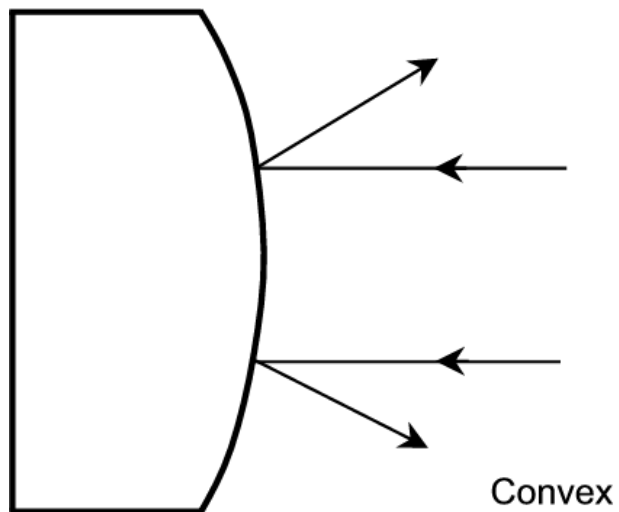

Figure 1.17

The same effect can be achieved with polished metals.

Assignment 2:

1. Try the following:

Polish the surface of a large serving spoon to get it to shine.

Look at your own image in the concave and on the convex side of the spoon and compare the shape of the reflections.

Draw the differences in the spaces that are provided:

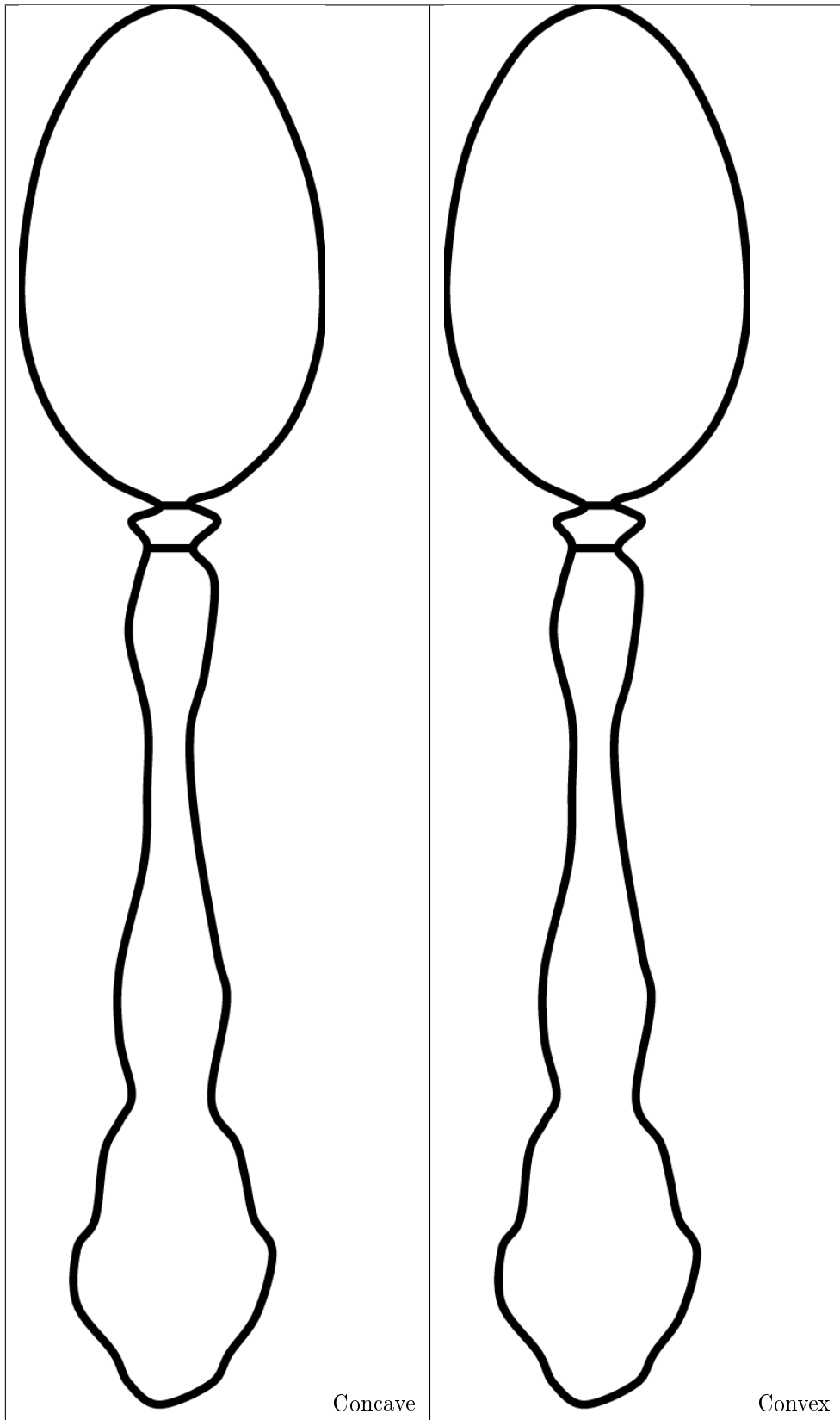
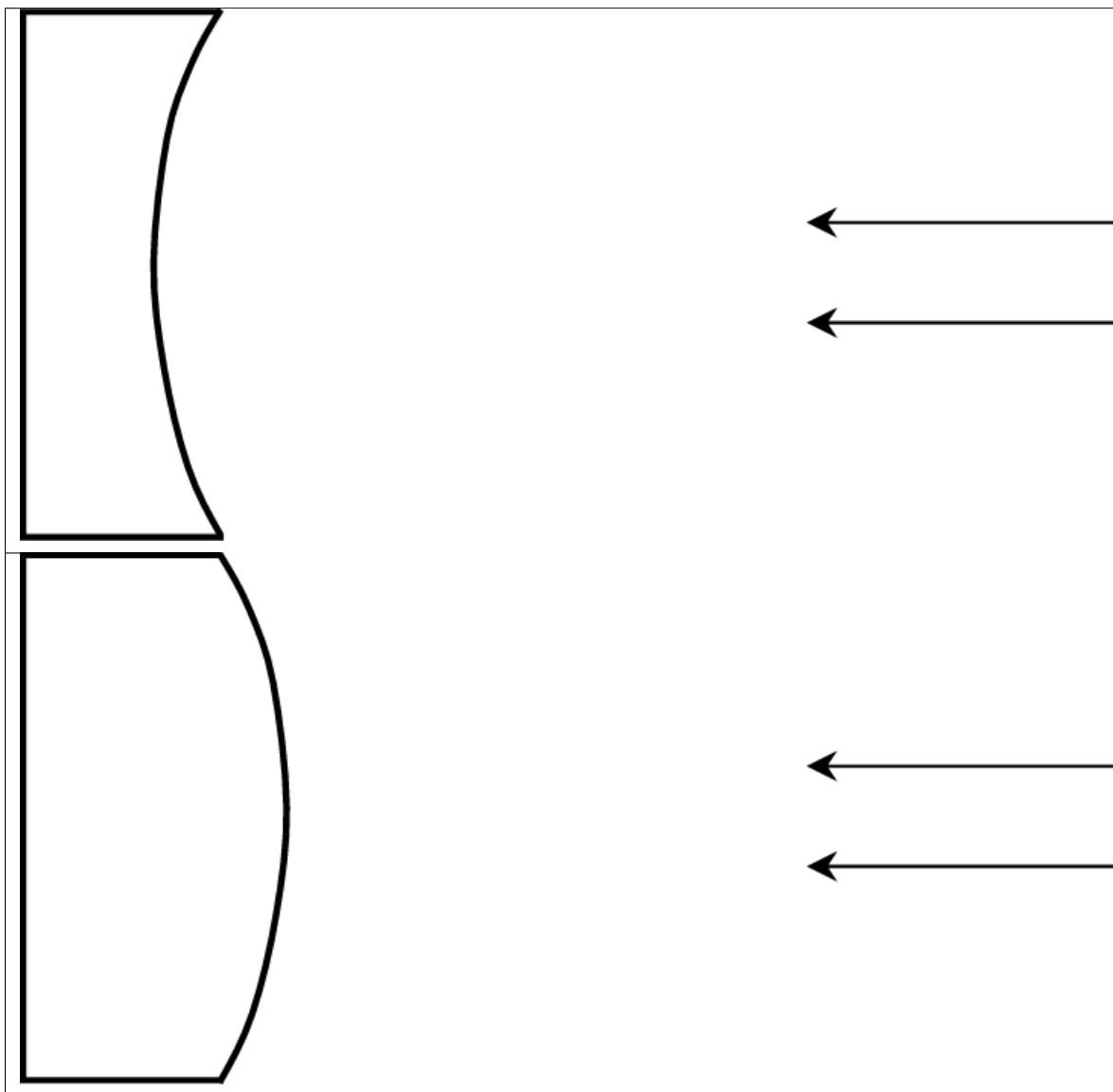

Table 1.5

Draw convergent and divergent beams from the right to add to the following sketches. Get your educator to help you.

**Table 1.6**

Assessment of Sketches

Were you able to complete the sketches correctly?

[LO 2.4]

1.11.6 Assessment

LO 2: Constructing Science Knowledge:

The learner will know and be able to interpret and apply scientific, technological and environmental knowledge.

This is evident when the learner:

- recalls meaningful information;
- interprets information;

2.4 applies knowledge.

1.11.7 Memorandum

Assignment 1:

LIGHT

- **LIGHT** is another common type of energy.
- You parents or teachers would like to have "eyes at the back of their heads" or would like you to believe that they see everything. We know that this is impossible, though, and for a simple reason
- Light travels along a straight line. Light can change direction, though. This can be achieved in two ways:

REFLECTION:

- We see this happening in the case of **mirrors**.

When a beam of light arrives at a certain angle, it will be reflected at the same angle.

1.11.7.1 ANGLE OF INCIDENCE = ANGLE OF REFLECTION

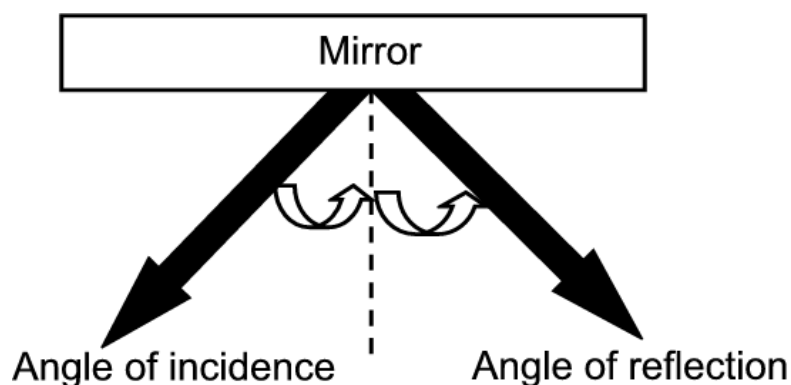

Figure 1.18

CURVED MIRRORS

- Curved mirrors have many applications.
- They enlarge and distort images.
- A mirror could be **CONCAVE**

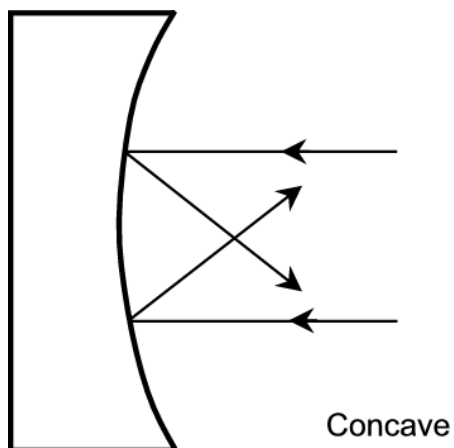

Figure 1.19

-
- It will **CONVERGE** light beams towards a fixed point, the **FOCUS**.
 - Other mirrors may be **CONVEX**.
 - They will cause light beams to **DIVERGE** (spread apart)
 - This scales down the image.
 - An application of this is evident in the rear view mirror of a motor car or in winged mirrors.

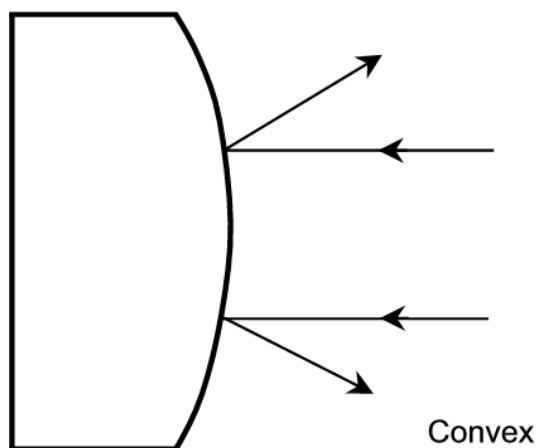

Figure 1.20

- Try the following:
 - Polish the surface of a large serving spoon to get it to shine.
 - Look at your own image in the concave and in the convex side of the spoon and compare the effect of the shape on the reflections.

Draw the differences in the spaces that are provided:

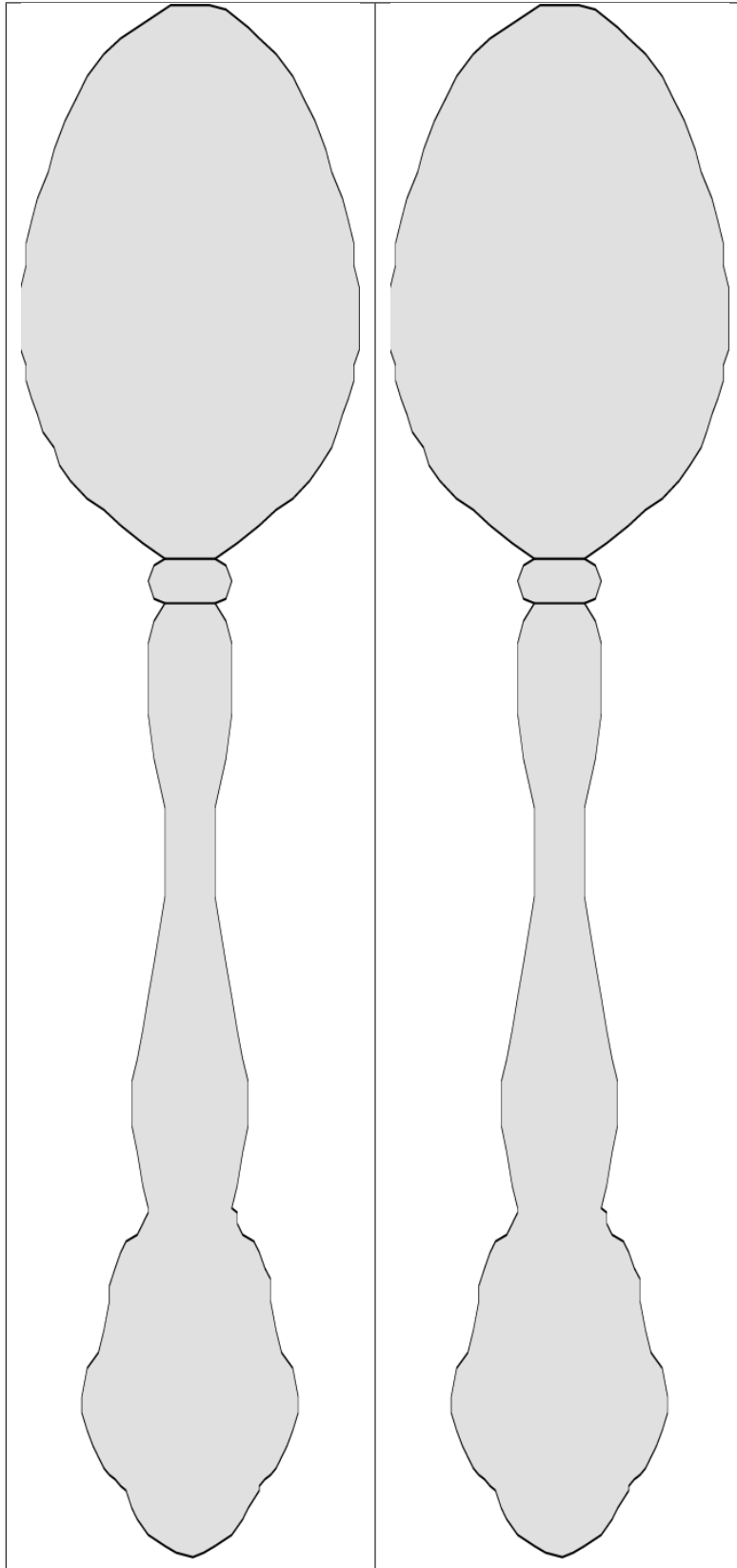

Table 1.7

1.12 Refraction of white light¹²

1.12.1 NATURAL SCIENCES

1.12.2 Grade 8

1.12.3 Energy: Electricity, heat and light

1.12.4 Module 12

1.12.5 The refraction of white light

1.12.5.1 ACTIVITY:

1.12.5.2 To investigate the refraction of white light [LO 2.1, LO 2.4]

Splitting up of white light:

- This phenomenon can be demonstrated in the classroom by directing a beam of light through a PRISM. A prism is a triangular bar of glass or perspex. When this is done, you will see that white light is a combination of all the colours of the rainbow – this range of colours is known as the SPECTRUM.
- Red, having the longest wavelength, will experience the least refraction. Blue light, on the opposite side of the SPECTRUM, having the shortest wavelength, will show the greatest degree of refraction.

Assignment 1:

Ask your educator to demonstrate refraction.

Complete the sketch that follows by using coloured pencils to indicate the spectrum.

Assessment of the Sketch of the Spectrum

Were you able to complete the sketch correctly?

[LO 2.1]

Spectacles **relieve the problems of people who suffer from short-sightedness or long-sightedness.**

Assignment 2:

Differentiate between:

Near-sightedness:

Long-sightedness:

The lenses of spectacles can be like the reflective surfaces you learnt about earlier, convex or concave. These lenses are shaped on both sides and are therefore biconvex or biconcave.

¹²This content is available online at <<http://cnx.org/content/m20030/1.1/>>.

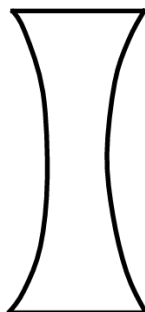

Figure 1.21

This shape is _____

Draw these lenses, showing the refraction that results from each type of lens. You might need to ask your educator's help.

Assessment of the Sketch of the Spectrum

Were you able to complete the sketch correctly?

[LO 2.4]

1.12.6 Assessment

LO 2: Constructing Science Knowledge:

The learner will know and be able to interpret and apply scientific, technological and environmental knowledge.

This is evident when the learner:

- recalls meaningful information;
- interprets information;

2.4 applies knowledge.

1.12.7 Memorandum

SPLITTING UP OF WHITE LIGHT:

Assignment 1:

- This phenomenon can be demonstrated in the classroom by directing a beam of light through a PRISM.
- A prism is a triangular bar of glass or perspex.
- When this is done, you will see that white light is a combination of all the colours of the rainbow – this range of colours is known as the **SPECTRUM**.
- The different colours that are combined to form white light do not move at the same speed.

- Red, having the longest wavelength, will experience the least amount of refraction. Blue light, on the opposite side of the **SPECTRUM**, having the shortest wavelength, will show the greatest degree of refraction.

Complete the sketch that follows by using coloured pencils to indicate the spectrum.

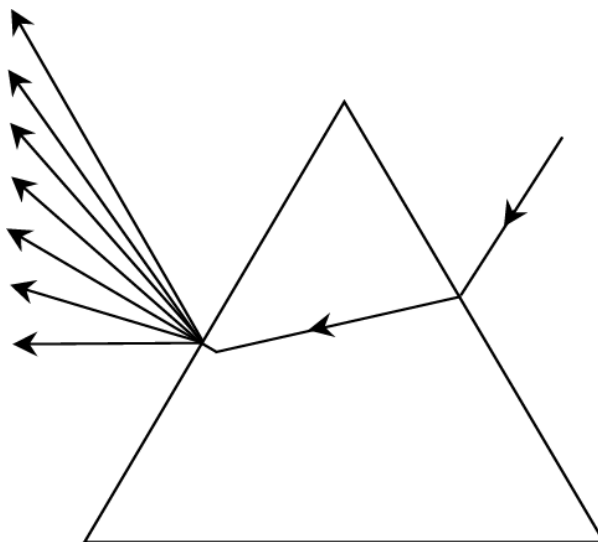

Figure 1.22

Spectrum colours:

Violet, blue, green, yellow, orange, red

- **Spectacles** relieve the problems of people who suffer from shortsightedness or farsightedness.
- **NEAR-SIGHTEDNESS:** People with this condition can see close objects well, but objects in the distance are unclear.
- **LONG-SIGHTEDNESS:** People with this condition can see distant objects clearly but find it difficult to focus on nearby objects and find reading difficult, for instance. Older people, in particular, develop this problem.
- The lenses of spectacles can be shaped, like the reflective surfaces about which you have learnt earlier, to be convex or concave. These lenses are shaped on both sides and are therefore biconvex or biconcave.

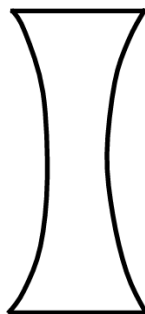

Figure 1.23

This illustrates a biconcave lens

- Further possibilities:
- Lens refraction
- Pinhole camera and binoculars

Chapter 2

Term 2

2.1 What is everything¹

2.1.1 NATURAL SCIENCES

2.1.2 Grade 8

2.1.3 MATTER: CLASSIFICATION

2.1.4 Module 13

2.1.5 What is everything made of?

Prior Knowledge from Grade 7:

Learners have learnt that all living and non-living things, are defined as matter.

Learners have learnt that matter occurs in three phases.

Learners have learnt that matter occupies space and that it has both volume and mass.

2.1.5.1 Class activity: Group discussion

1. Can you move with equal ease through all kinds of substances?
2. Is there any substance (matter) through which it is impossible to move?
3. Answer the following (yes/no) and give an example if no:
 - a) Can light move through all matter?
 - b) Can warmth move through all matter?
 - c) Can sound move through all matter?
 - d) Can electricity move through all matter?
 - e) Does matter always retain its form?

1. Classify matter observed around you according to the phases that you know by completing the following:

GAS:

LIQUID:

SOLID:

¹This content is available online at <<http://cnx.org/content/m20233/1.1/>>.

2.1.6 Memorandum

2.1.6.1 WHAT IS EVERYTHING MADE OF?

CLASS ACTIVITY: GROUP DISCUSSION

1. no
2. yes
3. a) no – walls, roofs
b) no – asbestos, wood
c) no – sound-proof material
d) no – insulators, e.g. plastic, rubber
e) no – heating and forces transform, e.g. by melting
4. gas: air; liquid: water; solid substance, table

2.2 Building blocks of matter²

2.2.1 NATURAL SCIENCES

2.2.2 Grade 8

2.2.3 MATTER: CLASSIFICATION

2.2.4 Module 14

2.2.5 The building blocks of matter

2.2.5.1 Class activity: Experiments in a Group context

2.2.5.2 EXPERIMENT 1: Movement of particles in liquids

Put a small quantity of table salt in a test tube, add some water and shake.

1. What has happened to the crystals?
2. Taste the water. Is there any salt in it?
3. What would have happened if you had not shaken the test tube?

Make deductions by completing the following:

4. The table salt became invisible, but the salt was still in the
5. The salt particles moved in among the particles of water. We say that it has
6. Water and table salt both consist of

2.2.5.3 EXPERIMENT 2: Movement of particles in liquids

Fill a glass beaker with water.

Use a drinking straw to gradually drop down potassium permanganate or food colouring into the water without agitating the liquid.

1. Observe what is happening and complete the series of sketches:



Figure 2.1

²This content is available online at <<http://cnx.org/content/m20236/1.1/>>.

Figure 2

Figure 3

Make deductions by completing the following:

2. The potassium permanganate or colouring spreads out from where there was to where there was until there was an equal quantity of it everywhere.
3. Particles therefore move
4. Liquids are also made up of

2.2.5.4 EXPERIMENT 3: Movement of particles in gases

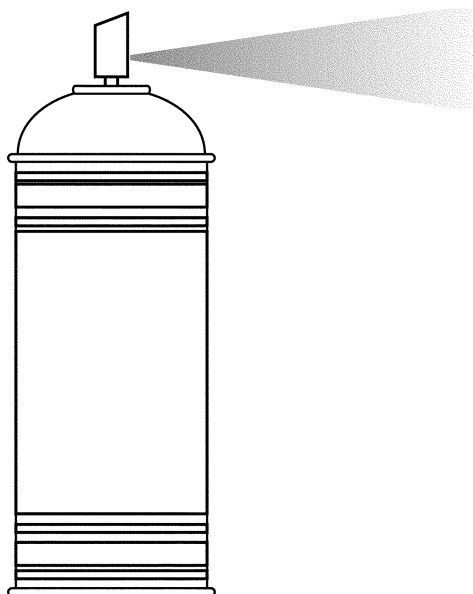

Figure 2.2

Make deductions from the gas spraying demonstration by completing the following sentences:

1. Gas particles move from where there is gas to where there is less until it is evenly dispersed.

1. Gases are therefore also made up of

Assessment of group work

Were you able to perform well in group work?

[LO 1.3]

Assessment of experimentation and deduction

Were you able to make correct deductions from the experiments?

[LO 1.2]

2.2.6 Assessment

Learning outcomes 1: Scientific investigations

The learner will be able to act confidently on curiosity about natural phenomena, and to investigate relationships and solve problems in scientific, technological and environmental contexts.

We know this when the learner

1.2 is able to execute an investigation and collect data.

1.3 is able to evaluate data and communicate findings.

2.2.7 Memorandum

EXPERIMENT 1:

1. crystals dissolve

2. yes

3. You would see more crystals lying at the bottom.

DEDUCTION:

- water
- dissolved
- small particles

EXPERIMENT 2:

DEDUCTIONS:

- much – little
- spontaneously
- particles

EXPERIMENT 3:

DEDUCTIONS:

- much
- particles

2.3 Phase changes of matter³

2.3.1 NATURAL SCIENCES

2.3.2 Grade 8

2.3.3 MATTER: CLASSIFICATION

2.3.4 module 15

2.3.5 Phase changes of Matter

Prior Knowledge:

- Matter has three phases: solid substances, liquid substances and gases

³This content is available online at <<http://cnx.org/content/m20238/1.1/>>.

2.3.5.1 Class activity: Reading skill

In the heart of a Cape winter

Adventurers went camping in the Cedar Mountains.

The night brought a fall of snow that

Glistened in the early morning light.

Slowly, surely, the ice was melted by the wintry sun

And water ran in rivulets to the riverbed.

A camper scooped up a billycan of the stream's water

He struck a match to light his fire

And soon steam billowed from his billycan!

1. Name all the phases of water mentioned in the text – list all the descriptive words.
2. Name the source of energy that causes:
 - a. the ice to melt
 - b. the water to steam
3. a. In which phase do particles of water have the greatest freedom of movement?
b. Which phase presents the strongest attraction between particles of water?
4. The phases of water are also an important part of nature, as the **WATER CYCLE** becomes possible because of it. Fill in the following:



Figure 2.3

The Water Cycle

6. The following illustrations represent phase changes. Explain what happens to the water in each instance:



Figure 2.4



Figure 2.5

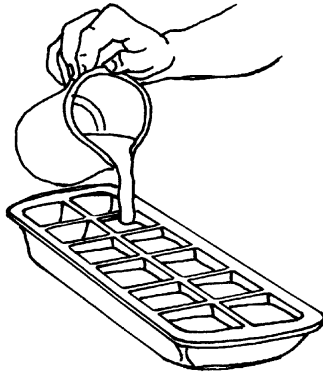

Figure 2.6



Figure 2.7

Assessment of reading skills

Were you able to make the correct deductions from the text?

[LO 2.3]

2.3.5.2 ASSIGNMENT

2.3.5.3 Find out the following:

(You could use the given web addresses or any other source for research.)



Figure 2.8

Why ice floats on water.– www.geocities.com (iceberg+ float)

How snowflakes are formed.– google.com (snowflakes)– www.edu.pe.ca/rural/chemist

Why alcohol (as in Schnapps or Witblits) does not freeze in the freezer.

What the boiling point of fluids like cooking oil and alcohol is.– www.ucc.ie – (boiling points)

Paste or write the information on the facing page.

Assessment for assignment

Has the information been collected and recorded?

[LO 1.3]

7. Each substance has its own boiling and freezing point.

Water freezes at

Water boils at

[U+F058] Do you know the following? [U+F057]

A fourth phase of matter has been discovered – it is known as PLASMA.

It only occurs at excessively high temperatures and in stars.

Read more about PLASMA!

<http://scsc.essortment.com>

2.3.6 Assessment

Learning outcomes 1: Scientific investigations

The learner will be able to act confidently on curiosity about natural phenomena, and to investigate relationships and solve problems in scientific, technological and environmental contexts.

We know this when the learner

1.3 is able to evaluate data and communicate findings.

Learning outcomes 2: Constructing science knowledge

The learner will know and be able to interpret and apply scientific, technological and environmental knowledge.

We know this when the learner

2.3 is able to interpret information.

2.3.7 Memorandum

1. snow; ice (solid substance) – water; river water (liquid) – steam (gas)
2. a) sun b) fire
3. a) steam (gas) b) snow/ice
4. spaces smaller in solid substances
5. 1 – evaporation; 2 – transpiration; 3 – cloud formation / condensation
4 – precipitation (rain, snow, etc.)
6. condenses; melts; freezes (crystallises); evaporates

2.4 Crystals and solutions⁴

2.4.1 NATURAL SCIENCES

2.4.2 Grade 8

2.4.3 MATTER: CLASSIFICATION

2.4.4 Module 16

2.4.5 crystals and solutions

- In the previous unit, mention was made of the formation of snowflakes.

Snow Crystals

- Each snowflake is unique and is formed when drops of water vapour in the atmosphere condense as snow crystals.

⁴This content is available online at <<http://cnx.org/content/m20244/1.1/>>.

- Snow crystals develop six “arms” from a six-sided prism. Each “arm” grows differently as it is affected by continual minute temperature variations
- Snow crystals combine to form snowflakes.
- Some of the most valuable stones in the world consist of solid matter in the form of crystals.
- Diamonds, rubies and sapphires are examples of precious stones. The atoms of these crystals form specific patterns.
- Crystals have flat sides known as *facets* – they can take the form of triangles, rectangles, or many other shapes.
- Minerals can be identified according to the crystalline form.
- The basic form of crystals vary – salt, for instance, is cubical.
- Most crystals have to be polished to reveal their beauty.

[U+F058] Do you know the following? [U+F057]

Sand is composed of quartz crystals. These crystals are shaped by constantly being knocked or rubbed against each other.

Read about QUARTZ WATCHES

Google.com (quartz +sand)

Rochhounding ar.com



Figure 2.9

Class Activity: Making a Solution

- Fill a glass beaker with cold water.
 - Add a teaspoon of salt or sugar to the water and stir.
 - Continue stirring until the substance stops dissolving.
1. How many spoonfuls of the substance did you add?
 - Repeat the experiment with an equal amount of hot water.
 2. What do you observe?
 3. What deduction can be made?
 4. Explain why warm water is more effective as a solvent:
 - Pour the solutes into watch-glasses and leave these on the classroom window sill for some days.
 5. What do you observe after a few days?
 6. What happened to the water?
 - Examine the crystals through a magnifying glass or a microscope.

2.4.5.1 ASSIGNMENT: Draw a couple of crystals to show their form.

Assessment for demonstration

Are you able to make correct deductions and communicate your findings?

[LO 1.3; LO 2.3]

2.4.5.2 Class Project

2.4.5.3 ASSIGNMENT:

Compile a scientific report on your investigation.

Grow your own crystals at home or in the classroom

You will need:

- alum powder (obtainable from a chemist)
- glass jars
- cotton thread and a pair of scissors
- a drinking straw
- elastic band

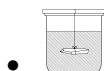

Figure 2.10

Fill the jar with hot water.

- Add alum powder by the method explained in the previous experiment – you will obtain a saturated solution. Use a watch-glass for crystals to form.
- Use the cotton thread to attach the crystals to the drinking straw and suspend them in the jar to a depth of three-quarters down the jar.
- Bend the straw and firmly attach it to the jar with the elastic band to hold it in position.

You will see crystals developing within a few days.

N.B.: Your educator could also let you grow copper sulphate crystals in the classroom.

Assessment of class project

Were you able to plan and execute the project, evaluate the data and apply your knowledge by handing in a properly compiled scientific report?

[LO 1.1; LO 1.2; LO 1.3; LO 2.4]

Problem Solving

Suppose you have a saturated solution, with excess crystals lying at the bottom of the beaker: Why would the crystals disappear if you began to heat the saturated solution slowly?

Assessment of problem solving

Were you able to provide an acceptable explanation for the problem?

[LO 2.4]

[U+F058] Do you know the following? [U+F057]

The gigantic rocks that form the Giant's Causeway in Northern Ireland are hexagonal crystals that were formed when molten rock cooled down rapidly.

www.geocities.com/amegman_uk/symmetry.html

2.4.6 Assessment

Learning outcome 1: Scientific investigations

The learner will be able to act confidently on curiosity about natural phenomena, and to investigate relationships and solve problems in scientific, technological and environmental contexts.

ASSESSMENT STANDARD: We know this when the learner

1.1 is able to plan investigations;

1.2 is able to execute an investigation and collect data;

- is able to evaluate data and communicate findings

Learning outcome 2: Constructing science knowledge

The learner will know and be able to interpret and apply scientific, technological and environmental knowledge.

ASSESSMENT STANDARD: We know this when the learner

2.3 is able to interpret information.

2.4 is able to apply knowledge.

2.4.7 Memorandum

CLASS ACTIVITY: MAKING SOLUTIONS

- Warm water contains more energy and crystals dissolve much faster in this
- Evaporation leads to crystallisation

ASSIGNMENT: CLASS PROJECT

- The scientific report must include the following:

Purpose

Method

Materials

Results

Deduction

PROBLEM SOLVING:

- The particles of warm water have more kinetic energy and are therefore further apart – more salt particles can fit into the spaces.

2.5 Atoms⁵

2.5.1 NATURAL SCIENCES

2.5.2 Grade 8

2.5.3 MATTER: CLASSIFICATION

2.5.4 Module 17

2.5.5 Atoms

- We have already mentioned the fact that atoms are the smallest particles in the composition of matter.

But what is the size of an atom and what is it like?

- The diameter of an atom is 0,000 000 001m – which is one millionth of a millimetre!
- When you inflate a balloon, which then seems to contain nothing, you need to consider that it will contain approximately one billion gas atoms (100 000 000 000 000 000)!
- One cubic millimetre of table salt (as much as will cover the head of a pin) will contain approximately 70 million atoms!

⁵This content is available online at <<http://cnx.org/content/m20250/1.1/>>.

- If each of the atoms in a grain of sand were the size of the head of a pin, the grain of sand would have a diameter of two kilometres!
- Atoms are rightfully regarded as the building blocks of matter, but there also are subatomic particles, which we know as **Protons**, **Neutrons** and **Electrons**.

Ask your educator for help with drawing the atoms of hydrogen and of oxygen:

2.5.5.1 Class Project

POSTER – Scientists through the ages

- Gather information about scientists like **Ernest Rutherford** (1911) and **Neils Bohr** (1913) and their contribution to present-day knowledge of atoms.
- Collect pictures and bring the information you have gathered to the class.
- Work together as groups to produce a poster dealing with **scientists through the ages**. We'll be adding other names to the list as we work through the module.

Assessment of class project

Did you collect the information and assemble the poster, honouring scientists through the ages for their efforts?

[LO 1.1; LO 1.2; LO 1.3; LO 3.1]

[U+F058] Do you know the following? [U+F057]

There are subatomic particles known as muons, gluons, and gravitons!

There are particles that are smaller than electrons known as quarks and leptons.

Quarks have strange names, like: *up*, *down*, *strange*, as well as *up and down*

Read more about these strange things, which are the smallest known particles.



Figure 2.11

www.geocities.com/omegaman_uk/2002

2.5.6 Assessment

Learning outcomes 1: Scientific investigations

The learner will be able to act confidently on curiosity about natural phenomena, and to investigate relationships and solve problems in scientific, technological and environmental contexts.

We know this when the learner:

- is able to plan investigations;
- is able to execute an investigation and collect data;
- is able to evaluate data and communicate findings.

Learning outcomes 3: Science, society and the environment

The learner will be able to demonstrate an understanding of the interrelationships between science and technology, society and the environment.

We know this when the learner:

3.1 is able to show appreciation of science as a human endeavour.

2.5.7 Memorandum

Project

2.6 Molecules⁶

2.6.1 NATURAL SCIENCES

2.6.2 Grade 8

2.6.3 MATTER: CLASSIFICATION

2.6.4 Module 18

2.6.5 MOLECULES

2.6.5.1 Class Activity

Building a Molecule

- Separate the balls into three groups according to colour.
- Each colour (pattern) represents a group of atoms.

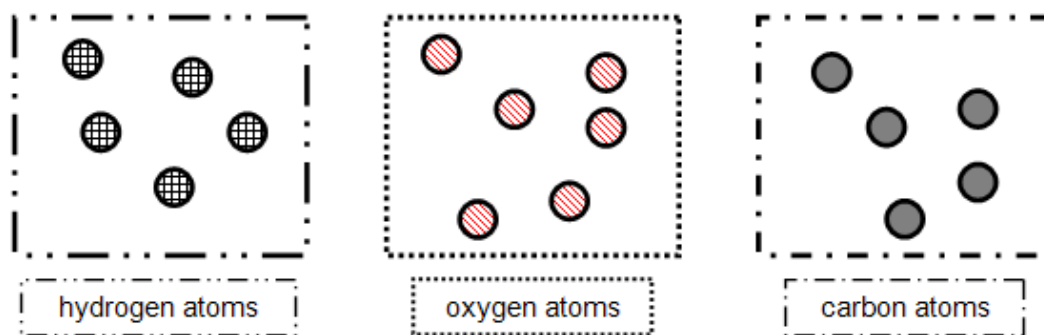

Figure 2.12

- Now build models according to the following designs:

⁶This content is available online at <<http://cnx.org/content/m31830/1.1/>>.



Figure 2.13

A. two atoms of hydrogen + one of oxygen



Figure 2.14

B. two atoms of oxygen + one of carbon

Answer the following questions by referring to the above:

1. Here (**A**) you have built a molecule known as
- Here (**B**) you have built a molecule known as
2. Explain what you think is represented by the rods.
3. Molecules are combinations of
4. What does hydroxide look like?
5. And ozone?

Assessment of model-building activity

Were you able to build the models?

[LO 2.2; LO 2.3]

Assignment

Sustainable Resources

- Find out what ozone is and why it is important for life on earth.
- Report what you find to the class as part of a campaign to promote awareness of endangered resources.
- Organise an exhibition in the classroom or in the school.

www.atm.ch.cam.ac.uk/tour⁷

Assessment of campaign to promote awareness

Did you participate in the campaign to make other people aware of the ozone layer and all the issues surrounding it?

[LO 3.2]

⁷<http://www.atm.ch.cam.ac.uk/tour>

2.6.6 Assessment

Learning outcomes 2: Constructing science knowledge

The learner will know and be able to interpret and apply scientific, technological and environmental knowledge.

We know this when the learner

2.2 is able to categorise information;

2.3 is able to interpret information.

Learning outcomes 3: Science, society and the environment

The learner will be able to demonstrate an understanding of the interrelationships between science and technology, society and the environment.

We know this when the learner:

3.2 understands sustainable use of the earth's resources.

2.6.7 Memorandum

1. Water and carbon dioxide
 2. Bonds
 3. O^2
 4. O^3

2.7 Elements and compounds⁸

2.7.1 NATURAL SCIENCES

2.7.2 Grade 8

2.7.3 MATTER: CLASSIFICATION

2.7.4 Module 19

2.7.5 Elements and compounds

Elements

- One of the basic sets of information in the natural sciences is represented in the list of elements.
- We refer to it as the *Periodic Table*.
- There are 112 elements in this table, and 90 of them occur naturally on our planet and as far as we know in the surrounding space.
- The rest are manufactured synthetically in laboratories.
- The elements are arranged according to qualities like mass and density, and according to how they are chemically compounded.

2.7.5.1 Assignment

- Collect information on **Mendeleev** (1834-1907) and on how he devised the periodic table.
- Add this to your poster about **scientiststhrough the ages**.

<http://smallfry.dmu.ac.uk/chem/tables>

⁸This content is available online at <<http://cnx.org/content/m31829/1.1/>>.

2.7.5.2 Class Activity: Listening skills

Listen attentively to the educator's explanation and complete the following.

The Periodic Table

1. The horizontal lines are known as
2. The vertical lines are known as
3. In what part of the periodic table do we find the metals?
4. Which metals are stored under paraffin? Why?
5. What do we call these metals?
6. In what part of the periodic table do we find the non-metals?
7. Which non-metal is stored under water? Why?
8. Where do we find most of the gases? Explain this
9. Which gases do not react with other substances?
10. What is the name of this group of gases?
11. Name the lightest gas
12. Which elements occur in liquid phase at room temperature?
13. Which element sublimates?
14. In which phase do most elements occur at room temperature?
15. Why do we place particular elements in the same group?

Elements and their Symbols

Symbols for elements

No	Name	Symbol	Phase at room-temperature	Metal or non-metal	Interesting facts
1	Hydrogen				
2	Helium				
3	Lithium				
4	Beryllium				
5	Boron				
6	Carbon				
7	Nitrogen				
8	Oxygen				
9	Fluorine				
10	Neon				
11	Sodium				
12	Magnesium				
13	Aluminium				
14	Silicon				

Figure 2.15

15	Phosphorus				
16	Sulphur				
17	Chlorine				
18	Argon				
19	Potassium				
20	Calcium				

Figure 2.16

26	<i>Iron</i>				
29	<i>Copper</i>				
30	<i>Zinc</i>				
35	<i><u>Bromium</u></i>				
47	<i>Silver</i>				
82	<i>Lead</i>				
80	<i>Mercury</i>				
28	<i>Nickel</i>				
92	<i>Uranium</i>				
24	<i>Chrome</i>				
53	<i>Iodine</i>				
27	<i>Cobalt</i>				
	<i>Gold</i>				

□

Figure 2.17

- Transfer the names of the elements and their symbols to the periodic table on the following page.

1. Gives off a blinding white light when it burns (like the sparklers that are burnt for birthday celebrations).

2. The main metal used in spacecraft and satellites.

3. The element that forms rust when it is in contact with oxygen.

4. The gas used to fill balloons to make them float.

5. The metal used for most electricity conductors.

6. The element with the fewest electrons in its atomic structure.

7. Valuable metal used for jewellery, coins and photographic films.

8. The yellow non-metal found in hot water springs and volcanoes and which contributes much to acid rain; it forms part of matches and fireworks and occurs in many medicines.

Figure 2.19

9. A halogen that is a fluid.

10. Inert gas in light bulbs.

11. A magnetic metal used in heat-resistant alloys.

12. Element that ensures healthy teeth.

13. Which non-metal will ignite spontaneously if it is exposed to oxygen? (You occasionally see it out at sea at night.)

14. The element used most commonly in computers and transistors.

15. The germicidal element used in swimming pool purifiers.

16. The element that occurs in all chemical compounds.

Figure 2.20

17. The element that burns with a violet light in oxygen.

18. The metal used as a finish on most bathroom taps.

19. Gas used in fluorescent lights.

20. Poisonous substance in insecticides that has also been used by murderers (Find out about Daisy de <u>Melcker</u>).

21. Metal used for window frames, especially at the coast.

22. The most abundant gas in the atmosphere.

23. The rare gas that has a bright green flame.

24. The metallic part of table salt.

25. Metal used for roof coverings and kitchen sinks.

Figure 2.21

[LO 2.1]

[U+F058] Do you know the following? [U+F057]

Some elements, like

CARBON

occur in various forms:

diamonds

coal, and the

graphite in your pencil!

<http://education.jlab.org/itselemental/ele006>

<http://mineral.galleries.com>

2.7.6 Assessment

Learning outcome 2: Constructing science knowledge

The learner will know and be able to interpret and apply scientific, technological and environmental knowledge.

We know this when the learner

2.1 is able to recall significant information;

2.2 is able to categorise information.

2.7.7 Memorandum

1. periods
 2. groups
 3. below left and in the transition block
 4. Li, Na, K – reactive with water vapour
 5. Alkali metals
 6. Below right
 7. P – reactive with oxygen
 8. On the extreme right
 9. Gases on extreme right
 10. Noble gases
 11. H
 12. Br and Hg
 13. Iodine
 14. Solid substance
 15. Corresponding qualities
- The PERIODIC TABLE OF ELEMENTS
1. periods
 2. groups
 3. below left and in the transition block
 4. Li, Na, K – reactive with water vapour
 5. Alkali metals
 6. Below right
 7. P – reactive with oxygen
 8. On the extreme right
 9. Gases on extreme right
 10. Noble gases
 11. H
 12. Br and Hg
 13. Iodine
 14. Solid substance
 15. Corresponding qualities
- ELEMENTS AS SYMBOLS

The Elements and their Symbols

No	Name	Symbol	Phase	Metal or non-metal	Interesting fact
1	Hydrogen	H	G		Lightest gas
2	Helium	He	G		Stable gas; balloons
3	Lithium	Li	V	M	
4	Beryllium	Be	V	M	
5	Boron	B	V		
6	Carbon	C	V		All organic substances
7	Nitrogen	N	G		In abundance in atmosphere
8	Oxygen	O	G		Essential – respiration
9	Fluor	F	G		
10	Neon	Ne	G		Neon lights/fluorescent lights
11	Sodium	Na	V	M	
12	Magnesium	Mg	V	M	Burns with white light
13	Aluminium	Al	V	M	Light metal
14	Silicon	Si	V		Sand

Figure 2.22

15	Phosphorus	P	V		Ignites spontaneously
16	Sulphur	S	V		Yellow powder
17	Chlorine	Cl	G		Toxic gas
18	Argon	Ar	G		
19	Potassium	K	V	M	
20	Calcium	Ca	V	M	Teeth

Figure 2.23

26	Iron	Fe	V	M	Haemoglobin; rust
29	Copper	Cu	V	M	
30	Zinc	Zn	V	M	
35	Bromine	Br	VL		
47	Silver	Ag	V	M	Noble metal
82	Lead	Pb	V	M	
80	Mercury	Hg	VL	M	
28	Nickel	Ni	V	M	Coins
92	Uranium	U	V	M	Nuclear reactors
24	Chromium	Cr	V	M	Taps
53	Iodine	I	V		Sublimate
27	Cobalt	Co	V		Weather ornaments
	Gold	Au	V	M	

Figure 2.24

GROUP WORK: QUIZ

1. Mg
2. Titanium
3. Fe
4. He

5. Cu
6. H
7. Ag
8. S
9. Br
10. Ar
11. Co
12. Ca
13. P
14. Si
16. Cl
17. K
18. Cr
19. Ne
20. Cyanide
21. Al
22. N
23. Kr
24. Na
25. Zinc

CLASS ACTIVITY: RECOGNITION OF METALS AND NON-METALS

Metals:

Non-metals:

1. shiny, hard
2. gold
3. demand
4. study of metals
5. alloy
- 6.

METALS	NON-METALS
Hard and shiny	Different colours; not very hard
Pliable and malleable	Brittle, breaks
Conducts heat	No
Conducts electricity	No

Figure 2.25

7. Pliable – long threads stretched out.
Malleable – hammered into thin plates/sheets.

GROUP WORK: QUIZ

1. Mg

2. Titanium
3. Fe
4. He
5. Cu
6. H
7. Ag
8. S
9. Br
10. Ar
11. Co
12. Ca
13. P
14. Si
16. Cl
17. K
18. Cr
19. Ne
20. Cyanide
21. Al
22. N
23. Kr
24. Na
25. Zinc

2.8 Metals and non-metals⁹

2.8.1 NATURAL SCIENCES

2.8.2 Grade 8

2.8.3 MATTER: CLASSIFICATION

2.8.4 Module 20

2.8.5 METALS AND NON-METALS

- A *metal* typically is a hard, shiny and strong element that is able to conduct heat and electricity.
- *Iron* is the most commonly used metal in the world in which we live, though not in its pure form. When iron is combined with a small amount of a non-metal like carbon we obtain an **alloy**.
- The *study of metals* is known as **metallurgy**.
- *Gold* is generally regarded as a metal that symbolizes wealth and prosperity, while *platinum* and *palladium* are valuable because of their use in electronics and specialized engineering.
- *Steel* is known everywhere and millions of tons of steel are used annually to manufacture items such as washing machines, cars, ships and trains. *Stainlesssteel* is also used for cutlery. For this, it is made into an alloy with the use of hard, shiny *chromium*.
- A variety of substances can be added to iron to form *alloys*, e.g. manganese, phosphorus, silicon and sulphur.
- *Aluminium*, again, is used extensively for cold drink cans, ladders and objects that are required to be light and rust free. Aluminium is the third most common chemical element on earth as much of the earth's crust is made up of it. Copper and magnesium are usually added to aluminium to make it suitable for industrial use.
- *Metals* can be recycled successfully to protect our natural resources – the gold and silver used in electrical circuits (and in false teeth!), particularly.
- *Bronze* – a mixture of copper and tin - is one of the most ancient of alloys.
- *Brass* is an alloy of copper and zinc.

2.8.5.1 Class Activity

Recognition of metals and non-metals



Figure 2.26

- Identify as many substances as possible from the illustration and classify them as metals and non-metals according to the main element of their substance.

⁹This content is available online at <<http://cnx.org/content/m20263/1.1/>>.

1. Which feature did you consider to determine whether substances were metals or non-metals?
2. Do you think the secretary is prosperous? Provide a reason for your answer?
3. Which substance is taking over from this metal in industry? From what is it made?
4. What is metallurgy?
5. What is steel?
6. The following are the distinctive features of metal. Write down the distinctive features for non-metals:
METALS
hard and shiny
pliable and malleable
conducts heat
conducts electricity
7. What is the difference between pliable and malleable?
Assessment of recognition
Were you able to do the classification correctly and to apply your knowledge?
[LO 2.2; LO 2.4]

2.8.6 Assessment

Learning outcomes 2: Constructing science knowledge

The learner will know and be able to interpret and apply scientific, technological and environmental knowledge.

We know this when the learner

- is able to categorise information;

2.4 is able to apply knowledge.

2.8.7 Memorandum

Metals:

Non-metals:

1. shiny, hard
2. gold
3. demand
4. study of metals
5. alloy

6. NON-METALS

Hard and shiny - Different colours; not very hard

Pliable and malleable - Brittle, breaks

Conducts heat - No

Conducts electricity - NO

7. Pliable – long threads stretched out.

Malleable – hammered into thin plates/sheets.

2.9 Compounds and mixtures¹⁰

2.9.1 NATURAL SCIENCES

2.9.2 Grade 8

2.9.3 MATTER: CLASSIFICATION

2.9.4 Module 21

2.9.5 COMPOUNDS AND MIXTURES

Prior Knowledge

- In the previous section of the work we learnt what elements are and that they consist of atoms.
- We mentioned that atoms do not occur in isolation, but are combined in molecules.

2.9.5.1 Class Activity: Practical Investigation

Investigation of physical qualities of elements

Your educator will help you to investigate the physical features of individual elements and the changes that occur when they combine.

1. Describe the iron filings:
2. Describe the sulphur:
3. Is the iron attracted by the magnet?

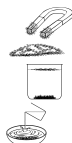

Figure 2.27

4. Is the sulphur attracted by the magnet?
 5. What do you deduce from this?
 6. Add a little carbon bisulphide (CS_2) to the iron.
What happens?
 7. Add a little carbon bisulphide (CS_2) to the sulphur.
What happens?
 8. What do you deduce from this?
- Pour the contents of the test tubes into two watch-glasses.
9. What do you see when the carbon bisulphide has evaporated?

Investigation of physical qualities of mixtures

Add iron filings to the sulphur:

1. What does the mixture look like?
2. What happens when the magnet is brought closer to the mixture?
3. What can you deduce from this?
4. Now add CS_2 to the mixture. What happens?

¹⁰This content is available online at <<http://cnx.org/content/m20269/1.1/>>.

5. Can you separate the mixture?
6. Suggest two methods of separation

2.9.5.2 Class Activity (continued): Demonstration

1. what happens when iron and sulphur are heated together?
 2. Is a new substance formed? Explain your answer?
 3. Has the substance retained any magnetic qualities?
 4. Is this substance soluble in carbon bisulphide?
 5. Can the substance be reconverted to the original elements?
 6. What was required for the reaction to occur?
 7. What kind of transfer of energy took place?

:

Assessment of experiment

Were you able to plan the steps (AS 1.1), execute them (AS 1.2) and communicate your findings (AS 1.3)?

[LO 1.1; LO 1.2; LO 1.3]

2.9.6 Assessment

Learning outcome 1: Scientific investigations

The learner will be able to act confidently on curiosity about natural phenomena, and to investigate relationships and solve problems in scientific, technological and environmental contexts.

ASSESSMENT STANDARD: We know this when the learner

- 1.1 is able to plan investigations;
 - 1.2 is able to execute an investigation and collect data;
- is able to evaluate data and communicate findings

2.9.7 Memorandum

INVESTIGATION INTO PHYSICAL QUALITIES OF ELEMENTS

1. grey, hard
2. yellow powder
3. yes
4. no
5. Metals are magnetic.
6. nothing
7. sulphur dissolves
8. Metals do not dissolve in carbon bisulphide.
9. crystals – sulphur

INVESTIGATION INTO PHYSICAL QUALITIES OF MIXTURES

1. yellow-grey
2. Only iron filings are attracted.
3. Only metal is magnetic.
4. Only sulphur dissolves.
5. yes
6. Dissolves S and evaporates again – crystals back on magnet.

CLASS ACTIVITY: DEMONSTRATION

1. Fused into a new substance.
2. yes – looks different; own qualities

3. no
4. no
5. yes, with effort
6. heat
7. heat – chemicals
8. Complete the following comparative table.

Table 2.2

2.10 Separation of mixtures¹¹

2.10.1 NATURAL SCIENCES

2.10.2 Grade 8

2.10.3 MATTER: CLASSIFICATION

2.10.4 Module 22

2.10.5 SEPARATION OF MIXTURES

- Different methods of separation are used for different mixtures.

The educator will explain and may demonstrate the METHODS that are listed:

- Sorting by hand – sort according to size, form and colour
- Filtration – one of the substances is soluble
- Evaporation – dissolves in water and water evaporates leaving salts behind
- Separating funnel – two liquids with different densities
- Distillation – use a Liebig condenser to heat, evaporate and condense

APPARATUS:

Sketch of filtration and distillation apparatus and a separating funnel.



Figure 2.28

¹¹This content is available online at <<http://cnx.org/content/m20271/1.1/>>.

2.10.5.1 Activity: Select a method of separation

Select and write down a method of separation for the following mixtures:

- Sand and salt
- Beans and peanuts
- Squash syrup and water
- Oil and water
- Different coins

2.10.5.2 Assignment

Give a **step by step explanation** with **sketches** of the method you would follow to:

- a) separate sand from salt.
- b) separate squash syrup from water.
 1. Which method would you use to obtain fresh water from sea water?
 2. Why is this method not used to add to fresh water sources?
 3. What is the difference between a distillate and a filtrate?
 4. Explain what fractional distillation is and name two industries in which it is used.

2.10.5.3 Project

How would you separate water and alcohol?

- Also find out something about *fractional distillation*.
- Suggestion: use what you have found out about the boiling point of substances (learning unit 3).
- *Sketches form an important part of a project !*
- Submit the project on the date set by the educator.

Assessment of the project

Were you able to plan the project (AS 1.1), collect data (AS 1.2) and evaluate and communicate your findings (AS 1.3), as well as apply knowledge (AS 2.4)?

[LO 1.1; LO 1.2; LO 1.3; LO 2.4]

2.10.6 Assessment

Learning outcome 1: Scientific investigations

The learner will be able to act confidently on curiosity about natural phenomena, and to investigate relationships and solve problems in scientific, technological and environmental contexts.

ASSESSMENT STANDARDS: We know this when the learner

- 1.1 is able to plan investigations;
- 1.2 is able to execute an investigation and collect data;

- is able to evaluate data and communicate findings

Learning outcomes 2: Constructing science knowledge

The learner will know and be able to interpret and apply scientific, technological and environmental knowledge.

ASSESSMENT STANDARD: We know this when the learner

- 2.4** is able to apply knowledge.

2.10.7 Memorandum

Mixture Method

Sand & salt Filter
Beans & peanuts Manual sorting
Squash syrup & water Distillation
Oil & water Separating funnel
Different coins Manual sorting
Sketches – the correct apparatus

1. Distillation
2. Cost
3. Distillate – fluid condenses after distillation
4. filtrate – fluid that is filtered
5. filtering at different boiling points, e.g. at oil refineries and in the spiritis (alcohol) industry.

PROJECT

Alcohol boils at 79°C – fractional distillation removes alcohol; water is left behind.
Regulation of temperature, using a thermometer is very important.
Sketch of how the Lieg condenser is set up is important.

Chapter 3

Term 3

3.1 Prehistoric life¹

3.1.1 NATURAL SCIENCES

3.1.2 Grade 8

3.1.3 BIODIVERSITY

3.1.4 Module 23

3.1.5 PREHISTORIC LIFE

For millions of years, life on earth consisted of microscopic single cell organisms only. True animals, like jellyfish and sponges, appeared about 700 million years ago.

They had soft bodies, but the development of shells, teeth and claws has made it possible for us to determine their appearance. How do we do this? By studying newly discovered fossils.

Finds of fossils dating from after the Cambrian period include animals like crocodiles and sharks.

Some animals quickly became extinct when conditions changed. Others were able to adapt and survive. Massive extinctions have occurred at various times in the history of the earth.

The age of the earth is counted in billions of years.

Find out more about this: Visit www.ucamp.berkeley.edu/exhibit/geology.html²

Like clock time that is divided into hours, minutes and seconds, the history of the earth can be divided into four large “blocks”. We refer to these as AEONS. The first three aeons together are known as the Precambrian period. Our information about this period is scant because few fossils have survived to be studied.

The last period is known as the Proterozoic aeon. This aeon commenced approximately 540 million years ago and is divided into four eras.

The eras are divided into periods that might have lasted for 2 to 80 million years each.

3.1.5.1 Activity: TO DO RESEARCH AND TO COLLECT DATA

1. Explain what you understand by geological time:
2. Use the circle to illustrate geological time as described above.
3. What would have caused the massive extinctions referred to in the above passage?
4. Explain what fossils are.
5. How do you think scientists determine the age of the earth? Find out about **carbon dating**.

¹This content is available online at <http://cnx.org/content/m20274/1.1/>.

²<http://www.ucamp.berkeley.edu/exhibit/geology.html>

3.1.5.2 RESEARCH: CARBON DATING

- www.howstuffworks.com/carbon-14³
- or: [www. Enchantedlearning.com/subject/dinosaurs/dinofossils/fossildating.html](http://www.Enchantedlearning.com/subject/dinosaurs/dinofossils/fossildating.html)

6. Find out about **EVOLUTION** as documented.

- Bear in mind that this is a sensitive topic and that not all people hold the same opinions. The scientist, however, has a duty to examine all phenomena and theories and to share his / her deductions with other people. Each individual can then decide whether he or she agrees or not. **Make an informed decision!**

3.1.5.3 RESEARCH: EVOLUTION

- Search in google.com

Assessment of RESEARCH:

Could you find any information on carbon dating and evolution?

[LO 1.2]

3.1.6 Assessment

Learning outcomes 1: Scientific investigations

The learner will be able to act confidently on curiosity about natural phenomena, and to investigate relationships and solve problems in scientific, technological and environmental contexts.

This is evident when the learner

1.2 is able to conduct an investigation and collect data.

3.1.7 Memorandum

Activity: COMPREHENSION TEST AND RESEARCH

- Preparation – read about carbon dating and find sources of information on evolution.
- As well as mass extinctions.
- Find appropriate video material.

3.2 Fossils⁴

3.2.1 NATURAL SCIENCES

3.2.2 Grade 8

3.2.3 BIODIVERSITY

3.2.4 Module 24

3.2.5 FOSSILS

Fossils are the remains of dead plants, animals, bacteria and other life forms that lived millions of years ago and were then petrified.

³<http://www.howstuffworks.com/carbon-14>

⁴This content is available online at <<http://cnx.org/content/m20280/1.1/>>.

Fossils are the petrified remains of organisms, e.g. teeth, bones, bark or shells. They may also be the tracks or waste products of organisms.

1. When an animal or organism dies, the soft parts decay first. The rest is buried below the sand or in mud.
2. Over millions of years, chemical changes and the intense pressure of overlying layers result in the petrification of these remains.
3. Water that seeps through such remains also effects changes. Petrified forms are retained very well.
4. Movement of the earth plates brings fossils to the surface.

3.2.5.1 Activity: TO DO RESEARCH ON THE FORMING OF FOSSILS

What is a palaeontologist?

What does SA law say about fossils? www.ru.ac.za/pssa/pssalaw.html⁵

3.2.5.2 ASSIGNMENT: Draw a flow diagram to illustrate the process by which fossils are formed.

Assessment of the flow diagram:

Were you able to draw a meaningful flow diagram of the fossilisation process?

[LO 2.2]

Adaptations – Fossils

3.2.5.3 Activity: TO INTERPRET INFORMATION

Study the following sketches of fossils and try to make deductions concerning their feeding and locomotion:

⁵<http://www.ru.ac.za/pssa/pssalaw.html>



Figure 3.1

Skull of a primitive amphibian

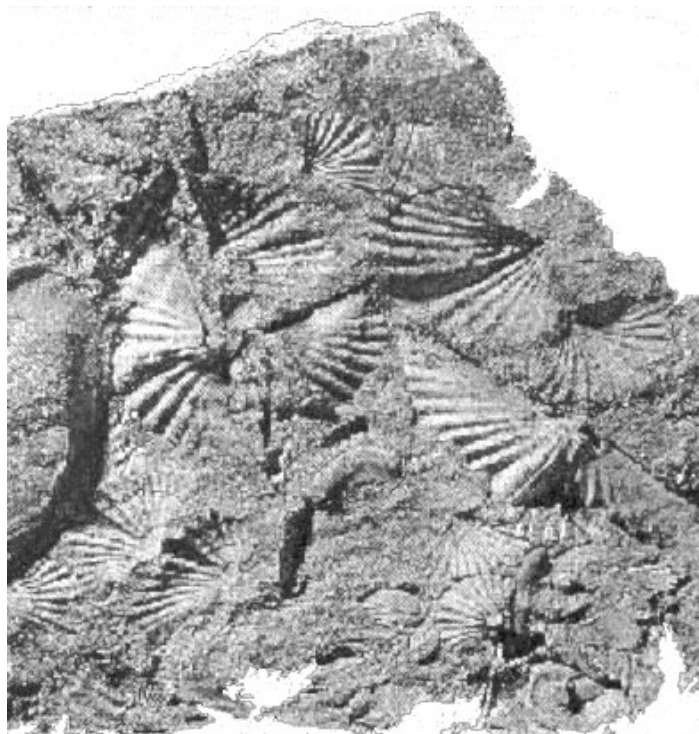

Figure 3.2

Brachiopod shells in a 500 – 300 million year-old marine deposit



Figure 3.3

Skull of a South African dinosaur (*Mossospondylus*)



Figure 3.4

A fly found in the 90 million years old deposits of the Orapa diamond crater (Botswana)
Assessment of deduction:

Could you make correct deductions from the pictures of fossils?

[LO 2.3]

3.2.6 Assessment

Learning outcomes 2: Constructing Science Knowledge

The learner will know and be able to interpret and apply scientific, technological and environmental knowledge.

This is evident when the learner

- is able to categorise information
- is able to interpret information

3.2.7 Memorandum

Class activity: SKETCHES of FOSSILS

- Find sources of information on fossils, palaeontologists and excavations.
- www.ru.ac.za/pssa/pssalaw.html - fossils and SA law

3.3 Life on earth⁶

3.3.1 NATURAL SCIENCES

3.3.2 Grade 8

3.3.3 BIODIVERSITY

3.3.4 Module 22

3.3.5 LIFE ON EARTH

All plants and animals are divided into groups according to their characteristics. Can you remember what we call the process by which this division is performed?

Classification

- Test your memory:
- Animals are divided into TWO main groups according to the presence or absence of a
- Animals that do not have an internal skeleton are known as
- Animals with an internal skeleton are known as
- Vertebrates are divided into

⁶This content is available online at <<http://cnx.org/content/m20287/1.1/>>.

3.3.5.1 Activity: TO CLASSIFY INFORMATION

- Cut out the pictures on this page and paste them on another sheet of paper under the appropriate heading (Fish, Amphians, Reptiles, Birds, Mammals). List three external features of each group. (Remember that features may not be visible in the pictures.)

**Figure 3.5**

Fish eagle *Haliaeetus vocifer*

**Figure 3.6**

Rhinoceros *Diceros bicornis*

**Figure 3.7**

Leguan *Varanus niloticus*

**Figure 3.8**

Common frog *Rana temporaria*



Figure 3.9

Common carp *Cyprinus carpio*

Assessment of classification:

Could you apply the sketches correctly and list the correct features?

[LO 2.2]

The classification of living organisms is performed according to an international system designed by scientists. This makes it possible for people from all language groups and from all over the world to know precisely which organism is meant when information is offered or received.

Carl Linnaeus (1707-1778), a Swedish doctor, botanist and zoologist, has had the most important influence on our present classification system.

- Names given to organisms are mainly of Latin origin (so it is “Greek” to most of us).
- Each organism bears a "NAME" and a "SURNAME".
- The name represents the species – it refers to similarities in structure, function and reproduction potential (the chromosome number is the same).
- The surname represents the Genus – it indicates a group of related species.
- The rule for writing this has INTERNATIONAL validity.
- The Genus name is written first and with an initial capital letter followed by lower case letters.
- This is followed by a space and the species name, using lower case letters throughout.
- If the name is printed, italic script is used. In hand-written format, the two words are underlined separately.
- The scientific name of the earthworm, for instance, is *Lumbricus terrestris*.
- This system is referred to as a BINOMINAL system (two names).

3.3.5.2 Activity: TO APPLY A SIMPLE CLASSIFICATION SYSTEM

1. What is a biologist?
 2. What is a botanist?
 3. Write the scientific name of the earthworm according to the international rule:
 4. Why is classification important?
 5. What is the meaning of *terre* in the scientific name of the earthworm?.
 6. Use of the information provided on the page of sketches and write the scientific name in one column and the common name in another column.
 7. Examine the names of the different robins (birds)
 - Chorister robin: *Cossypha dichroa*
 - Heuglin's robin: *Cossypha heuglini*
 - Natal robin: *Cossypha natalensis*
 - Cape robin *Cossypha caffra*
- Explain the meaning of the Genus and the species names as in the binominal classification system with reference to these names.

Assessment of APPLICATION:

Could you answer the questions?

[LO 2.4]

ASSIGNMENT [LO 1.2]:

- Do research on Carl Linnaeus as a scientist. Write a report of approximately 100 words.

3.3.6 Assessment

Learning outcomes 1: Scientific investigations

The learner will be able to act confidently on curiosity about natural phenomena, and to investigate relationships and solve problems in scientific, technological and environmental contexts.

This is evident when the learner

1.2 is able to conduct an investigation and collect data.

Learning outcomes 2: Constructing Science Knowledge

The learner will know and be able to interpret and apply scientific, technological and environmental knowledge.

This is evident when the learner

- able to categorise information;

2.4 is able to apply knowledge.

3.3.7 Memorandum

Activity: APPLICATION OF CLASSIFICATION

- Explain classification and the binominal system.
- Sources dealing with Carolus Linnaeus.

3.4 Survival: habitat⁷

3.4.1 NATURAL SCIENCES

3.4.2 Grade 8

3.4.3 BIODIVERSITY

3.4.4 Module 26

3.4.5 SURVIVAL: HABITAT

Why are some plants and animals only found in specific areas?

3.4.5.1 Activity: TO EVALUATE INFORMATION

Work with a partner. Discuss the above question and then compile two tables of three columns each and fill in any example of which you may know. Use examples of wild animals and plants in their natural environment. Do not name pets, farm animals or garden plants.

PLANTS:

Plant name

Where does it grow?

Why does it grow there?

ANIMALS

Animal name

Where does it occur?

Why does it occur there?

Assessment of DISCUSSION ON HABITAT:

Could you obtain significant answers from the discussion?

[LO 1.3]

3.4.5.2 Poster: Group work 4 - 5 learners

Plan a poster to show the habitats of animals from your list. Select two divergent habitats and try to handle the design in an original manner. Include at least three animals in each habitat.

- Use drawings or pictures. Collect these and bring them to the lesson to complete the assignment.

Criteria:

- Approach the assignment as a research exercise and make use of the following steps:
 - Plan the investigation
 - Collect the data
 - Formulate and communicate your findings
- Formulate an elucidatory heading
- Use colour in your presentation
- Use a large text
- Include the names of the members of the group
- Delegate tasks
- Choose a group member to provide feedback

⁷This content is available online at <<http://cnx.org/content/m20288/1.1/>>.

Assessment of POSTER:

Did you participate constructively in this group activity by helping to plan the investigation (1.1), collect data (1.2) and communicate findings (1.3)?

[LO 1.1; LO 1.2; LO 1.3]

Surviving in a Habitat

Organisms live in a natural environment where they are able to find food, water and shelter to protect them against enemies.

Animals also need to find partners for pairing.

Some organisms are adapted to withstand all the onslaughts of the environment.

These **ADAPTATIONS** comprise a strategy for survival.

Every organism's **HABITAT** is the place where it lives.

Each one is adapted to its **NICHE** – this is its role and position in the environment.

3.4.5.3 Activity: TO INTERPRET INFORMATION AND APPLY KNOWLEDGE

Study the table of **STRATEGIES FOR SURVIVAL** exhibited by common garden plants and animals. Provide the purpose of each adaptation.



Figure 3.10

The citrus swallowtail butterfly has mouth parts that suck up nectar. The butterfly has strong wings.



Figure 3.11

The hairy caterpillar becomes a lovely but poisonous butterfly. The prickly hairs of the caterpillar protect it.



Figure 3.12

The rose bush has thorns and leathery leaves with sharp, short tips. Caterpillars eat the leaf margins.



Figure 3.13

The chameleon has bulging eyes that can move independently. It has four toes – two point forwards and two point backwards.

It has a long prehensile tail that can grip strongly.

It is also able to adapt its colour to its surroundings.



Figure 3.14

The seeds of the thistle form an umbrella-like plume that allows long-distance dispersal by wind.

3.4.5.4 Study the following sketches and complete the accompanying questions.

The Sugarbird



Figure 3.15

Which adaptations are visible?

The fiscal shrike



Figure 3.16

How has this bird adapted?

The praying mantis



Figure 3.17

Describe the adaptation of the praying mantis.

Assessment for ADAPTATIONS:

Could you make correct deductions by allocating information to categories and interpreting it?

[LO 2.3; 2.4]

3.4.6 Assessment

Learning outcomes 1: Scientific investigations

The learner will be able to act confidently on curiosity about natural phenomena, and to investigate relationships and solve problems in scientific, technological and environmental contexts.

This is evident when the learner

- 1.1 is able to plan investigations;
- 1.2 is able to conduct an investigation and collect data;
- 1.3 is able to evaluate data and communicate findings.

Learning outcomes 2: Constructing Science Knowledge

The learner will know and be able to interpret and apply scientific, technological and environmental knowledge.

This is evident when the learner

- 2.3 is able to interpret information;
- 2.4 is able to apply knowledge.

3.4.7 Memorandum

Activity: DISCUSSION ON HABITAT

- Instruct learners to do this discussion in dialogue (two learners to a group).

Poster: GROUP WORK – 4-5 LEARNERS

- Give advance instruction to learners for forward planning and finding of materials.

Activity: STRATEGIES for SURVIVAL

- Cutting and pasting activity.

3.5 Animals are adapted⁸

3.5.1 NATURAL SCIENCES

3.5.2 Grade 8

3.5.3 DIVERSITY

3.5.4 Module 27

3.5.5 SURVIVAL: HOW ANIMALS ARE ADAPTED TO THEIR WAY OF LIVING

Types of Adaptation

There are different types of adaptation. In this learning unit we shall be looking at adaptations that have to do with ways of feeding and protection by means of colour.

A. Adaptations with regard to Food

- To obtain food
- To ingest food

B. Adaptations with regard to colour

- For self-protection

A. Food-related Adaptation

All animals require food to remain alive. This food must firstly be found and the animals' bodies must, be adapted to ingest and digest the food.

FEEDING comprises both ingestion and digestion.

Activity: TO USE PRIOR KNOWLEDGE TO GAIN NEW KNOWLEDGE

The most common adaptations related to feeding are:(Complete from prior knowledge)

HERBIVORES

CARNIVORES

OMNIVORES

HERBIVORES

- Plant material does not provide much nutrient value. Herbivores therefore have to eat large amounts of leaf material.
- They need large stomachs (gizzards) for storing these amounts of food – some animals ruminate.
- Leaves may be hard and thorny and have rough stems and an unpleasant taste.
- Herbivores need powerful jaws and molars.

Name two examples of herbivores from each of the following categories:

1. mammals
2. birds
3. insects

CARNIVORES:

- Meat has better nutrient value but it has to be hunted and caught:
- Carnivores need to be fast and strong and have claws or powerful beaks.
- They need sharp teeth and powerful jaw muscles.
- They do not need to store large amounts of food in the alimentary canal.

⁸This content is available online at <<http://cnx.org/content/m20290/1.1/>>.

Name two examples of carnivores from each of the following categories:

1. mammals
2. birds
3. insects

OMNIVORES:

- As they eat both plant and animal material, they need to be adapted to eat both types of food: sharp as well as grinding teeth; well-developed digestive system; ability to catch prey.

Name two examples of omnivores from each of the following categories:

1. mammals
2. birds
3. insects

The most common adaptation in this regard is related to the **TEETH** in the skull of the animal.

- There are **FOUR** kinds of teeth: Incisors, Canines, Premolars, Molars.

Supply the function of each kind of tooth with the different ways of feeding of herbivores, carnivores and omnivores.

HERBIVORES: have to cut, gnaw and grind and therefore need strong incisors and molars.

CARNIVORES: have to bite and tear and therefore need strong incisors and canines. Molars are shaped like canines and not like grinders.

OMNIVORES: all teeth work equally well and are equally developed
[LO 2.1; 2.4]

3.5.5.1 Activity: TO IDENTIFY CORRECTLY

Teeth

Study the illustrations and answer the questions that follow:



Figure 3.18

1. Which drawing represents a molar? Explain your choice:
2. To which kind of animal might the molar belong?
3. Identify the other tooth and explain your choice:

ASSIGNMENT:

We have examined the ways in which animal teeth are adapted to particular ways of feeding. Draw upon your own knowledge of cats, lions and leopards and describe the ways in which the *bodies* of carnivores are adapted to their manner of feeding.

[LO 2.4]

B. Colour Adaptations

Each animal in nature is a possible **PREY** to another organism. They need to protect themselves in any way possible for the sake of **SURVIVAL**.

We are going to look at **COLOUR ADAPTATION** to illustrate ways of fooling enemies:

- **Camouflage** (colour adaptation to become unrecognisable)

- **Warnings** (colour adaptation to warn of poison or a bad taste)
- **Mimicry** (copying)



Figure 3.19

Camouflage

The animal seeks to blend into its natural environment by means of:

colour, e.g. green grasshoppers on grass

patterns, e.g. moth on the bark of a tree

stripes, e.g. some frogs among reeds

spots, e.g. the wings of a nightjar

colour changes, e.g. chameleons or fish

many marine animals have shiny white bellies and dark backs

colour changes that are seasonal, e.g. the polar fox

colour adaptation that accompanies adaptation of shape, e.g. stick insects or inch-worms

Warning colouring

- The animal has conspicuously bright colours to warn against bad taste, poisonousness or an unpleasant substance.
- This normally comprises red, yellow or white colouring against black.
- Examples:

Elegant grasshopper

Striped mongoose

Ladybirds

Wasps

- Other creatures, like some moths (e.g. the pine tree emperor moth) have large spots on its wings that look like eyes to frighten off predators.

Mimicry

- With this adaptation, one creature normally mimics another species that has survived successfully. Insects, especially, make use of this strategy.
- One insect provides the **MODEL**
- The other is the **MIMIC**
- The swallowtail butterfly (b) is a good example of a mimic. The milkweed butterfly (African monarch) (a) is the model.



Figure 3.20

- Another example is that of flies that mimic bees.

Activity: TO IDENTIFY EXAMPLES OF COLOUR ADAPTATION

Study the sketches and indicate the relevant type of adaptation



Figure 3.21



Figure 3.22



Figure 3.23



Figure 3.24

Assessment of APPLICATION:

Could you identify the adaptations correctly?

[LO 2.4]

3.5.6 Assessment

Learning outcomes 2: Constructing Science Knowledge

The learner will know and be able to interpret and apply scientific, technological and environmental knowledge.

This is evident when the learner

2.1 is able to recall meaningful information;

2.4 is able to apply knowledge.

3.5.7 Memorandum

Activity: IDENTIFICATION – teeth and dentition

- Obtain examples of skulls for the lesson

Activity: IDENTIFY - COLOUR ADAPTATION

- Cutting and pasting activity.

3.6 Plant adaptations⁹

3.6.1 NATURAL SCIENCES

3.6.2 Grade 8

3.6.3 BIODIVERSITY

3.6.4 Module 28

3.6.5 PLANT ADAPTATIONS

Like animals, plants have also made adaptations to survive under particular climatic conditions.

As water is of utmost importance for the survival of plants, their adaptations are related to the availability of water. Plants can be divided into three groups with regard to this type of adaptation.

- **XEROPHYTES** – minimal availability of water
- **MESOPHYTES** – moderate availability of water – as with most plants growing on land
- **HYDROPHYTES** – maximal availability of water

3.6.5.1 Activity: TO CLASSIFY PLANTS

Study the following sketches and classify the plants according to their structures as hydro-, meso- or xero-phytes. Attempt to provide at least one reason for your classification in each instance.



Figure 3.25



Figure 3.26

⁹This content is available online at <<http://cnx.org/content/m20296/1.1/>>.



Figure 3.27

3.6.5.2 Activity: TO EXPLAIN THE WAY IN WHICH SOME PLANTS ADAPT

HYDROPHYTE ADAPTATION EXPLANATION

Roots Poorly developed, only for anchoring

Leaves Large surface

Floating Cuticle (waxy layer) on surface

Air pockets in leaf

Stomata (small openings) on top

Stems

Very little strengthening tissue

Slimy layer

Rhizome (stores food)

XEROPHYTE ADAPTATION EXPLANATION

Roots

Shallow root system

Corky layer

Leaves

Few stomata, mainly on underside

Small or converted to thorns

Stems Thick and fleshy

Waxy layer

Could you supply correct explanations for each adaptation?

Assessment of assignment: [LO 2.4]

3.6.5.3 ASSIGNMENT: Story

The San most probably were the first people to live in Southern Africa and we still think of their ability to survive such dry conditions with astonishment. Water was a very limited resource.

But we do not have to go very far to discover some of the solutions that the San found centuries ago in nature and in plants (xerophytes), in particular.

Read about the natural vegetation of the desert-like parts of our country.

Write a story about the survival of a plant in the Kalahari Desert. Write this from the point of view of the plant. Let the plant do the talking to describe the conditions and how it manages to survive, and how it helps other plants, the San and animals to survive (its role in the food chain). Refer to the San people and how they used plants to survive.

Assessment of assignment:

3.6.5.4 Could you write a factually correct story about San culture and the Kalahari ecosystem?
[LO 3.1]

3.6.5.5 Class Activity: Adaptations in xerophytes



Figure 3.28



Figure 3.29



Figure 3.30



Figure 3.31

Examine the sketches of these unusual xerophytes – which adaptations do they exhibit?

ALOE
CACTUS
LITHOPS
WELWITCHIA

Match the items in the following columns by writing the letters from COLUMN C in the appropriate spaces in COLUMN B. More than one match is possible.

[LO 2.4]

3.6.6 Activity: TO CONDUCT A RESEARCH PROJECT

Most xerophytes are used as medicine and for a variety of other purposes in different cultures. Even primitive cultural groups practised science thousands of years ago by determining the value of plants and finding ways to use them.

Do research on the Internet, in books and in libraries.

Write a research report, using the following headings:

- Planning of the investigation (which has to include research through the Internet and books and through conversations with homeopaths and sangomas or inyangas, as well as one or two older people).
- Information gathered:

Examples of the use of plants by cultural groups in South Africa.

Discussion of three specific plants, including the aloe (*Aloe vera*) (characteristics of the plants and medicinal, economic or other value).

- Summary (summary of findings)
- List of references: books, web addresses, and persons.

Assessment of RESEARCH PROJECT:

[LO 1.1; LO 1.2; LO 1.3]

3.6.7 Assessment

Learning outcomes 1: Scientific investigations

The learner will be able to act confidently on curiosity about natural phenomena, and to investigate relationships and solve problems in scientific, technological and environmental contexts.

This is evident when the learner

- 1.1 is able to plan investigations;
- 1.2 is able to conduct an investigation and collect data;
- 1.3 is able to evaluate data and communicate findings.

Learning outcomes 2: Constructing Science Knowledge

The learner will know and be able to interpret and apply scientific, technological and environmental knowledge.

This is evident when the learner

- 2.4 is able to apply knowledge.

Learning outcomes 3: Science, society and the environment

The learner will be able to demonstrate an understanding of the interrelationships between science and technology, society and the environment.

This is evident when the learner

- 3.1 is able to understand science as a human endeavour.

3.6.8 Memorandum

Activity: IDENTIFICATION: PLANTS

- www.lithop.supanet.com

Activity: EXPLAIN THE FOLLOWING ADAPTATIONS

ASSIGNMENT: Story

- Do some reading about the natural vegetation of the arid regions of our country.
- Write a story about the survival of an animal in the Kalahari Desert. Write this from the point of view of the animal and from its situation in the food chain.

Class activity: XEROPHYTIC PLANTS – ADAPTATIONS

ASSIGNMENT: Research project

- Most xerophytes are used as medicines and in a variety of other applications, by various cultural groups.
- **The aloe** (*Aloe ferox*), in particular, has a wide range of applications – consult homeopaths, sangomas or an inyanga to find information in this regard.
- Do research through the internet, books and libraries.
- Write a research report with the following headings as a guideline:

Growing regions

Special properties of the plant, especially the leaves

Medicinal and economic value of the plant

- Include a list of all the sources and websites that you consult.

3.7 Sustainability¹⁰

3.7.1 NATURAL SCIENCES

3.7.2 Grade 8

3.7.3 BIODIVERSITY

3.7.4 Module 29

3.7.5 SUSTAINABILITY

The previous learning units focused on the survival strategies of organisms living on planet **EARTH**.

We know that the organisms and their **habitats** together make up the earth's variety (biodiversity) and that nature is maintained in perfect balance because of this **BIODIVERSITY**.

There are 250 000 higher species of plants, 19 000 species of fish and 10 000 species of reptiles. Many more species of insects have been recorded. This wealth of life forms ensures that:

- there is an atmosphere that has the right combination and balance for our survival;
- the soil remains fertile for new plants to grow so that we and other animals will always have food;
- water is re-circulated.

South Africa is the only country in the world that has a complete plant kingdom within its borders, namely the fynbos biome of the Western Cape.

We in South Africa are fortunate to have a particularly rich variety of plants and animals in our own country. Are we aware of this wealth?

BIODIVERSITY SUPPORTS SUSTAINABILITY!

People are at the helm, but often fail to do the right thing

¹⁰This content is available online at <<http://cnx.org/content/m20297/1.1/>>.

3.7.5.1 Activity: TO TAKE A STAND ON THE MAINTENANCE OF BIODIVERSITY IN NATURE

Discuss the following question during the lesson:

- Are people part of a natural ecosystem, or are they unwanted guests who interfere and disrupt the balance?

Report the outcomes of the discussion in your own words (the dominant opinion within the group).

[LO 3.2]

People are often accused of tapping nature's **resources** for their own selfish needs.

If today were a typical day on planet Earth, 336 km² of tropical forest will have been destroyed by the end of the day to provide wood and by making way for roads, farms and plantations. A total of 112 km² will have changed into desert because of overgrazing or poor farming practices.

One and a half million metric tons of dangerous waste will have been dumped in the environment. Various estimates suggest that 50 to 100 plant and animal species will shortly become extinct.

By the end of the day, the world will be a little warmer, the rain will be a little more acidic and the earth's web of life will be slightly more torn and tattered. (Chiras, 1993)

3.7.5.1.1 Scientists warn us against humankind's destructive trends. The idea of SUSTAINABILITY suggests that it is possible for nature and human beings to exist in a win-win relationship. At the recent world conference in Johannesburg, it became clear that many people believe that we can ensure a positive future for the whole world with the right MANAGEMENT SYSTEMS and the right INCLINATION.

3.7.5.2 Activity: TO REFLECT ON THE SUSTAINABILITY OF THE EARTH'S RESOURCES

1. List all the mistakes that people are making, with regard to the environment.
2. What do you understand as the meaning of SUSTAINABILITY?
3. Name THREE natural resources that are over-utilised.
4. Give the meaning of Mahatma Gandhi's words (quoted below) in your own words:
"The world contains enough for everyone's need, but not for everyone's greed."
5. Why should we give serious reconsideration to our use of the environment?

Important terms are:

- **HABITAT**: specific place where an organism lives
- **BIODIVERSITY**: the variety of life on earth
- **RESOURCES**: everything that we use for our survival

3.7.5.3 Activity: TO MAKE A PREDICTION ABOUT THE EARTH'S FUTURE

The earth is like a spacecraft – all the provisions have been supplied and the journey has to be continued self-supportively!

Create an A4 poster to represent your view of the earth as a spacecraft.

Assessment of SUSTAINABILITY:

Could you answer the questions and provide a good representation of the earth for your poster?

[LO 3.2]

3.7.6 Assessment

Learning outcomes 3: Science, society and the environment

The learner will be able to demonstrate an understanding of the interrelationships between science and technology, society and the environment.

This is evident when the learner

- understands sustainable use of the earth's resources.

3.7.7 Memorandum

Activity: READING SKILL:

- Instruct the class to do silent reading.

Class activity: POSTER – SPACECRAFT EARTH

- The earth is like a spacecraft – all its supplies have been provided and it has to set out on its voyage – completely self-supportively!!
- Create an A4 poster to depict your image of the earth as viewed as a spacecraft in the present time.

3.8 Sustainable activities¹¹

3.8.1 NATURAL SCIENCES

3.8.2 Grade 8

3.8.3 BIODIVERSITY

3.8.4 Module 30

3.8.5 SUSTAINABLE ACTIVITIES

SUSTAINABILITY: *How is this defined in the dictionary?* ...capable of being maintained at a steady level without exhausting natural resources or causing severe ecological damage (via Old French from Latin *sustinere* to hold up).

LIFE ON EARTH WILL ONLY BE SUSTAINABLE IF:

- nature is not harmed through the use of materials and the dumping of waste;
- resources are not exhausted;
- the well-being of the human race and all organisms is striven for.

principles for sustainable development:

- Plan needs
- Limit the threat to nature to the minimum
- Conserve nature for future generations
- Understand and manage human population growth

¹¹This content is available online at <<http://cnx.org/content/m20298/1.1/>>.

3.8.5.1 Activity: TO HAVE A CLASS DISCUSSION ON THE SUSTAINABILITY OF RESOURCES

SUSTAINABLE LIFE AND RESOURCE UTILIZATION

Indicate whether the following aspects are sustainable or not:

SOLAR ENERGY SYSTEMS

FOSSIL FUELS

MINING

FORESTRY

HYDRO ELECTRIC SCHEMES

NUCLEAR REACTORS

Discuss each briefly in terms of sustainability and add comments in each instance:

1. Solar energy systems:

2. Fossil fuel:

3. Mining:

4. Forestry:

5. Hydro electric schemes:

6. Nuclear reactors:

7. What is your final impression?

Assessment of CLASS DISCUSSION - RESOURCES:

Could you make correct deductions from the class discussion?

[LO 3.2]

3.8.6 Assessment

Learning outcomes 1: Scientific investigations

The learner will be able to act confidently on curiosity about natural phenomena, and to investigate relationships and solve problems in scientific, technological and environmental contexts.

This is evident when the learner

1.1 is able to plan investigations;

1.2 is able to conduct an investigation and collect data;

1.3 is able to evaluate data and communicate findings.

Learning outcomes 2: Constructing Science Knowledge

The learner will know and be able to interpret and apply scientific, technological and environmental knowledge.

This is evident when the learner

2.3 is able to interpret information;

2.4 is able to apply knowledge.

Learning outcomes 3: Science, society and the environment

The learner will be able to demonstrate an understanding of the interrelationships between science and technology, society and the environment.

This is evident when the learner

3.1 is able to understand science as a human endeavour.

3.8.7

3.9 World population¹²

3.9.1 NATURAL SCIENCES

3.9.2 Grade 8

3.9.3 BIODIVERSITY

3.9.4 Module 9

3.9.5 WORLD POPULATION

In the previous learning unit we mentioned that the growth in world population would determine whether sustainable development is possible and that we need to be thoroughly aware of this.

3.9.5.1 Activity 19:

3.9.5.2 TO INTERPRET INFORMATION ON THE WORLD POPULATION

- Study the STATISTICS that follows and calculate the natural growth per unit.

WORLD POPULATION GROWTH

PER UNIT OF TIME

PER YEAR: Births: 131 468 233 Deaths: 54 147 021

Natural growth: _____

PER MONTH: Births:10 955 686 Deaths:54 147 021

Natural growth: _____

PER DAY: Births: 360 187 Deaths: 148 348

Natural growth: _____

PER HOUR: Births: 15 008 Deaths: 6 181

Natural growth: _____

PER MINUTE: Births: 250 Deaths: 103

Natural Growth: _____

.....

- World population reached the **6 BILLION** mark on 12 October 1999.
 - Visit the web address www.census.gov/main/wwwpopclock.html¹³, as well as csf.colorado.edu/pop
1. What are the latest values on the World POP clock?
 2. What will these be by 2050?

Activity 20: TO REFLECT ON OWN ROLE IN ENSURING THE WELL BEING OF THE EARTH

- Write about your impressions of the future of human beings on planet Earth and on the role that you could play.

Assessment of impressions:

Did you provide meaningful impressions of the earth's FUTURE?

[LO 3.1]

¹²This content is available online at <<http://cnx.org/content/m20299/1.1/>>.

¹³<http://www.census.gov/>

3.9.6 Assessment

LEARNING OUTCOMES (LOs)

LO 3

SCIENCE, TECHNOLOGY AND THE ENVIRONMENT

Learners are able to show understanding of the underlying connections of technology, the community and the environment.

ASSESSMENT STANDARDS (ASs)

We know this when the learner:

3.1 understands science and technology in the context of history and personal knowledge;

- understands the impact of science and technology.

3.9.7 Memorandum

WORLD POPULATION

- Organise a visit to the computer centre or obtain sources from the internet for the use of the learners.
- Visit the www.census.gov website
- Graph paper for the exercise.

ASSESSMENT GRID: Transfer values

Chapter 4

Term 4

4.1 The ecosystem¹

4.1.1 NATURAL SCIENCES

4.1.2 Grade 8

4.1.3 ENVIRONMENT

4.1.4 Module 29

4.1.5 THE ECOSYSTEM

ECOLOGY is the study of organisms in their natural environment and the interaction between them.

4.1.5.1 ACTIVITY:

4.1.5.2 To be able to interpret representations of different ecological environments

4.1.5.3 [LO 2.2; LO 2.3]

QUESTIONS

1. What is an ECOLOGICAL ENVIRONMENT?
2. What, are the basic components or parts of all ecological environments?
3. *Bios* is the Greek word for *Life*.
What, do you think, the following concepts mean? (Ask your teacher to explain.)
 - 3.1 **abiotic**
 - 3.2 **biotic**
 - 3.3 **factor**

4. An ecological environment can be described as an ECOSYSTEM.

4.1 An ecosystem is

An **ECOSYSTEM** is, the living and non-living components of a certain environment and the interaction between the components.

The study of ecosystems and the interactions between the organisms and their environment is called **ECOLOGY**.

¹This content is available online at <<http://cnx.org/content/m20408/1.1/>>.

4.1.5.4 .**4.1.5.5 To examine part of a garden as an ecological environment (ecosystem)****4.1.5.6 [LO 1.1; LO 1.2; LO 2.1; LO 2.2]**

Your teacher will arrange a visit to a suitable garden in your neighbourhood, or perhaps just to a part of your school grounds. It must be an area where the gardener does not work every day.

- Why is that so?

1. Divide into groups and sit down in the garden. There must be quite a bit of space around each group. Sit absolutely still for at least five minutes.
2. Be aware of everything that can be observed.
3. Each group picks a single leaf (with permission) of each kind of plant that is visible in the area. Place it between two clean sheets of paper in a thick book. Give each plant your own name.
4. Count the number of plant and animal groups in your delimited area and tabulate the information below.
5. Make a list of all the non-living (abiotic) factors that determine the nature of the environment.

	TYPE of organism (list own)	NUMBER of organisms
Plants		

Table 4.1

	TYPE of organism (list own)	NUMBER of organisms
Animals		

Table 4.2

6. Abiotic factors:

Assessment of the GARDEN RESEARCH:

Were you able to carry out the assignment and write down results?

[LO 1.1; LO 1.2]

- So far you have determined the following:

That a **population** is a group of similar organisms in a certain **environment**. The numbers in your column graph indicate the **population size**. The population size can be determined by using various methods and formulas.

The home of a plant or animal is called its **habitat**.

The role that is played by an organism in its environment refers to the “work” that it does, and is called its **niche**.

A **community** is made up of all the populations that occur in one area.

A **herbarium** is made by collecting and storing leaf material as you have done. Ask your teacher to tell you more about this. You could also research this topic on your own. Why don't you ask your teacher to allocate some space in the classroom so that you can all exhibit your examples?

Let us see what you have learnt:

- Do the following exercise. Write down a letter from Column B next to the number that is related to it from Column A. Write these letters in the squares.

A	B
1. The place where organisms are found.	A. biotic
2. The number of organisms of one kind in an area.	B. herbarium
3. Place where dried plant material is stored.	C. habitat
4. Living part of the environment.	D. population
5. All the populations in an environment.	E. community
6. The role of an organism in its environment.	F. ecology
7. The study of organisms in their environment.	G. niche

Table 4.3

Assessment of column exercise
 Could you answer the questions successfully?
 [LO 2.1]

4.1.5.7 Assessment

LO 1: Scientific investigations:

The learner will be able to act confidently on curiosity about natural phenomena, and to investigate relationships and solve problems in scientific, technological and environmental contexts.

This is evident when the learner:

- plans investigations;
- conducts investigations and collects data.

LO 2: Constructing Science Knowledge:

The learner will know and be able to interpret and apply scientific, technological and environmental knowledge.

This is evident when the learner:

- recalls meaningful information;
- categorises information;

2.3 interprets information.

4.1.5.8 Memorandum

Activity : Interpreting representations of different ecological environments

Questions

- 1.. A defined area with all the living and non-living factors in it (biotic and a biotic components).
2. Light, air, water, soil, animals, plants.
- 3..
 - 3.1 a biotic:all non-living parts, e.g. air, water.
 - 3.2 biotic: all living organisms, e.g. plants, animals.
 - 3.3 factor: an element of cause that contributes to a result; the nature of something, e.g. an environment that has a determining effect.
- 4.a. An ecosystem is a particular area with all the living and non-living factors that determine the nature of the area, as well as the living organisms that occur in the area and interact with one another and with the non-living factors of the

Activity: Examining a section of the garden as an ecological environment (ecosystem)

The visit to the garden. Why must an uncultivated part of the garden be examined? The gardener should be persuaded to steer clear and not interfere.

Tables: learners compile their own lists:

Importance of location, date and time: A biotic factors vary continually and the behaviour and presence of organisms therefore also vary.

Column graph: Utilisation of both the X-axis and the Y-axis is important. The factor that affects the data or lends significance to it is entered on the x-axis. The effect of this factor is entered on the Y-axis. Ensure that the learners name the X- and Y-axes correctly and that they have a thorough grasp of the importance of it: X-axis: plant species; Y-axis: numbers representing each plant species.

Complete the following column-related question:

1. C

2. D
3. B
4. A
5. E
6. G
7. F

4.2 Different ecosystems²

4.2.1 NATURAL SCIENCES

4.2.2 Grade 8

4.2.3 ENVIRONMENT AND INTERACTIONS

4.2.4 Module 30

4.2.5 DIFFERENT ECOSYSTEMS

Our country has a wealth of widely differing kinds of ecosystems.

If possible, your teacher will take you to one or more of these ecosystems.

4.2.5.1 ACTIVITY:

4.2.5.2 To discuss the role of a grassland ecosystem

4.2.5.3 [LO 1.3]

In large parts of our country grass forms the greatest part of the ecosystems. We can also use the term BIOME to refer to the parts of the country that show more or less the same ecological characteristics. For instance, there is a grassland biome. A grassland biome can be described as a large ecosystem or it can be divided into smaller grassland ecosystems.

Knowledge of the grassland biome and grassland ecosystems is important in South Africa, because great parts of the country are utilized for grazing animals.

Game such as impala, buffalo and springbuck are also grazing livestock.

The type of grass in an ecosystem is mainly determined by the nature of the soil.

Grassland biomes are named according to the dominant grass type that is found in the system.

The main types of grassland ecosystems (actually biomes) are:

1. sweet veld – low rainfall areas; good livestock grazing;
2. sour veld – high rainfall areas; not very good grazing;
3. mixed veld.

Red grass (*Themeda triandra*) is a well-known grass type that is very nutritious for livestock.

Over-grazing is the most serious offence that a farmer can commit, because it leads to soil-erosion, desert creation and eventual famine.

Have a class debate on the following question:

- Is the practice of regularly burning grass good or bad for the environment?

- Write down the advantages and disadvantages of burning grassland, as mentioned in the debate, in the columns below:

²This content is available online at <<http://cnx.org/content/m20409/1.1/>>.

ADVANTAGES OF BURNING	DISADVANTAGES OF BURNING
.....
.....
.....
.....
.....
.....
.....
.....

Table 4.4

Assessment of DEBATE:

Have you made a meaningful contribution to the debate? [LO 1.3]

4.2.5.4 ACTIVITY:

4.2.5.5 To discuss forest/tree ecosystems

4.2.5.6 [LO 1.2; LO1.3; LO 2.4]

Trees are not only **producers**, but as a result of their size they also create a **habitat** for certain species.

Animal and plant species inhabit trees.

The leaf cover of trees provides **shelter** for animals, while the bark and fissures in the trees also provide a habitat for numerous insect species. The leaf cover also creates a shady environment in which shade-loving, low-growing plants can flourish.

The flowers and fruit borne by some trees are a **source of food** for many creatures.

The resin emitted by some trees is also important for certain animals.

When leaves or fruit fall from the trees and collect at the feet of the trees, another series of organisms can appear. The **decomposers**, such as micro-organisms that cause the dead material to decay and decompose, contribute to the decomposition of the nutrients so that they may return to the soil. **Humus** is formed in this way. Humus is dead organic material. Other creatures that live off decayed organic material, namely the **detritivores**, also promote this process of decomposition.

- Poster to illustrate the Role-players in a Tree Ecosystem
- Bring pictures of animals, trees and other plants to class. The teacher will divide the class into groups.
- Each group will prepare a poster to illustrate the mutual dependence of the trees, other plants and animals. Each group must present its poster to the rest of the class.
- Answer the following questions / follow the instructions arising from the class discussion:

QUESTIONS / INSTRUCTIONS

1. Supposing the tree on your poster were to fall over.
 - 1.1 Which organisms would die?
 - 1.2 Which organisms would move away?
 - 1.3 Which organisms would increase in number?
2. Describe the role played by trees in an ecosystem.
3. Ecologically speaking, why is it bad practice to rake up leaves under trees?
4. Name three more examples where humans harm ecosystems.

Assessment of POSTER and interpretation of related questions:

Were you able to use the joint information in order to answer the questions?

[LO 1.2; LO1.3]

4.2.5.7 ACTIVITY:**4.2.5.8 To discuss rock pool ecosystems****4.2.5.9 [LO 2.1; LO2.2; LO2.3]**

This ecosystem is extremely sensitive. The main factor that plays a role here, is TIDES.

The tide changes twice every 24 hours. As a result of the wave action, cold, oxygen-rich sea water washes over the rock pool communities. During low tide the water in the rock pools heats up and evaporation takes place. These changes contribute to the adaptation of the organisms that live in the rock pools so that they may survive the various challenges of nature.

1. Describe what you understand by “a rock pool”.
2. List all the abiotic factors that have an impact on rock pools.

Plants in rock pools

The most common plants are sea-weeds or sea-algae. They are red, green or brown.

Although they are not always green, they can also produce nutrients through photosynthesis. Therefore they are also producers.

They also provide nutrition for a wide range of other organisms that live off them, such as mussels and some sea-snails.

1. Do research in order to describe what each of the following is:
 - (a) filter feeders:
 - (b) scavengers:
2. What would the purpose of tentacles be in sea-anemones?
3. What kind of mutual dependence exists between the organisms in a rock pool?

Assessment of the interpretation of the SKETCHES

Could you distinguish the basic rock pool components?

[LO 2.1; LO 2.2; LO 2.3]

4.2.6 Assessment

LO 1: Scientific investigations:

The learner will be able to act confidently on curiosity about natural phenomena, and to investigate relationships and solve problems in scientific, technological and environmental contexts.

This is evident when the learner:

- plans investigations;
- conducts investigations and collects data;
- evaluates data and communicates findings.

LO 2: Constructing Science Knowledge:

The learner will know and be able to interpret and apply scientific, technological and environmental knowledge.

This is evident when the learner:

- recalls meaningful information;
- categorises information;
- interprets information;

2.4 applies knowledge.

4.2.6.1 Memorandum

Activity: Discussing the value of a grassland ecosystem

ADVANTAGES OF BURNING	DISADVANTAGES OF BURNING
<ul style="list-style-type: none"> • Hard seedpods that cover seeds crack open 	<ul style="list-style-type: none"> • Air pollution – smoke
<ul style="list-style-type: none"> • Species are rediscovered, e.g., the mountain rose 	<ul style="list-style-type: none"> • Animals and plants are injured and damaged, or killed
<ul style="list-style-type: none"> • Plants that grow aggressively are restricted 	<ul style="list-style-type: none"> • Organisms in the soil are destroyed – humus is reduced
<ul style="list-style-type: none"> • Younger plants provide better nutrition (green grass after a severe winter) 	<ul style="list-style-type: none"> • Grasses are weakened if burning is practised or occurs at the wrong time

Table 4.5

Activity: Discussing a forest / tree ecosystem

Questions

- Suppose the tree depicted in your poster were to topple over;
 - Plants that grow in the shade and have no resistance against direct sunlight.
 - Some creatures like birds and squirrels.
 - Decomposers like bacteria and fungi.
- Accept the answers offered by learners, but ensure that the following are listed: habitat, shelter, source of food, shade.
- Decomposition and the formation of humus are retarded: raw materials are not returned to the soil and the soil is impoverished.
- Overgrazing, introduction of exotic plants, pollution.

Activity: Discussing a rock pool ecosystems

- Accept the descriptions offered by learners. The following must form part of the information provided: saltwater, shallow water, high tide and low tide, extreme variations in a biotic conditions.
- Wave action, wind, drying out, solar heating, pollution by people.

Questions

- Research:
 - Feeders that use filtering: mussels: minute food particles are filtered out of the water that flows through delicate structures.
 - Carrion eaters: eaters of dead animals, e.g. crabs.
- Tentacles: These grab bits of food from all directions and stuff it into the mouth in the absence of the senses of sight and smell.
- Food-related aspects as touched on in earlier questions.
- Shelter: plants provide shelter against predators.

4.3 The role of plants in an ecosystem³

4.3.1 NATURAL SCIENCES

4.3.2 Grade 8

4.3.3 ENVIRONMENT INTERACTIONS

4.3.4 Module 34

4.3.5 THE ROLE OF PLANTS IN AN ECOSYSTEM

4.3.5.1 ACTIVITY:

4.3.5.2 To identify the role of plants

4.3.5.3 [LO 2.4]

- Complete the table by indicating either the description or the function. Complete the column to the right by pasting in some of the sketches (from the page with sketches) in the right place.

FUNCTION	DESCRIPTION	SKETCH
Nutrition		
Air filter		
	Birds build nests, insects lay eggs, predators and prey take cover here.	
Camouflage		
	Soil erosion is prevented and humidity is retained.	
	Soil is enriched.	

Table 4.6

- Write 270 words on the role of plants in ecosystems.

Assessment of ROLE IDENTIFICATION

Were you able to distinguish basic roles?

[LO 2.4]

4.3.5.4 ACTIVITY:

4.3.5.5 To discuss the role of animals in ecosystems

4.3.5.6 [LO 2.2; LO 2.4; LO 3.2]

- Complete the table by indicating either the description or the function. Complete the column to the right by either pasting in a picture or making a drawing in the right place.

³This content is available online at <<http://cnx.org/content/m20410/1.1/>>.

FUNCTION	DESCRIPTION	SKETCH
Nutrition		
Pollination		
	Mammals, birds, mice and insects distribute seeds.	
	The soil is enriched.	

Table 4.7

Assessment of CLASSIFICATION

Were you able to identify and classify basic ROLES? **LO 2.2; LO 2.4**

Advantages and Disadvantages of Animals

- Are all animals beneficial to the environment?
- Can animals be harmful to the environment?

- Write significant aspects that have been named by your classmates here:

Assessment of CLASS DISCUSSION

Were you able to list disadvantages? [**LO 3.2**]

4.3.6 Assessment

LO 2: Constructing Science Knowledge:

The learner will know and be able to interpret and apply scientific, technological and environmental knowledge.

This is evident when the learner:

- categorises information;

2.4 applies knowledge.

LO 3: Science, Society and the Environment

The learner will be able to demonstrate an understanding of the interrelationships between science and technology, society and the environment.

This is evident when the learner:

3.2 understands sustainable use of the earth's resources.

4.3.6.1 Memorandum

Activity: Identifying the role of plants

FUNCTION	DESCRIPTION	SKETCH
<i>continued on next page</i>		

	<ul style="list-style-type: none"> Plants store food that nourishes and keeps animals alive 	Baboon or maize plant
	<ul style="list-style-type: none"> Leaves absorb carbon dioxide and release oxygen 	Leaf with arrows indicating direction
Protection, Homes		Branches of trees
	<ul style="list-style-type: none"> Bark and leaves enable insects to be unnoticeable because of the similarity of lines and spots that are developed 	Moth against background of a tree trunk
Anchoring, enriching the soil		Roots of plants
Plant material returns to the earth		Leaves on the ground

Table 4.8

A paragraph dealing with the role of plants

- This should aim to provide practice in communicating through writing. The content of the previous table must be presented and expanded in a written paragraph.

Activity: Discussing the role that animals play in ecosystems

FUNCTION	DESCRIPTION	SKETCH
	<ul style="list-style-type: none"> Animals serve as food for other animals 	Lion with a zebra
	<ul style="list-style-type: none"> Insects pollinate flowers, for fruit to develop 	Butterfly on a flower
<i>continued on next page</i>		

Dispersal of seed	<ul style="list-style-type: none"> • Mammals, birds, mice and insects disperse seeds 	Mouse eating a fruit
Fertiliser	<ul style="list-style-type: none"> • The soil is enriched 	Antelope, rock rabbit or rabbit droppings

Table 4.9

CLASS DISCUSSION

- Can animals harm the environment?
- Yes – overgrazing, in particular, leads to the eradication of plants and thereby to soil erosion. Exotic animals can be harmful because of the way in which their numbers could increase in the absence of their natural enemies. This would result in the displacement of indigenous animals and even cause the eradication of specific animal and plant species.

The food pyramid

- Green plants, herbivores, carnivores, carrion eaters.
- Incline: the steeper the incline, the smaller the amount of energy or biomass that is lost from one level to the next.

Food chains related to a text for reading

- E.g. twigs / organic material - ants - antlion - gecko - snake
- Grass - locust - gecko - snake
- Twigs / organic material - field mouse - snake

4.4 Ecological relationships⁴

4.4.1 NATURAL SCIENCES

4.4.2 Grade 8

4.4.3 ENVIRONMENT AND INTERACTIONS

4.4.4 Module 35

4.4.5 ECOLOGICAL RELATIONSHIPS

Our study of the roles of organisms in ecosystems has shown that organisms do not exist in isolation. There are mutual relationships amongst all of them. All are dependent on each other to a lesser or greater degree.

Ecological relationships develop for many different reasons.

⁴This content is available online at <<http://cnx.org/content/m20411/1.1/>>.

4.4.5.1 ACTIVITY:**4.4.5.2 To identify the reasons for the relationships between organisms in nature****4.4.5.3 [LO 2.4]**

See whether you are able to write down a few reasons for the development of relationships between organisms in nature.

- Discuss your reasons with each other and decide which reason is the most important one:

Assessment of your ability to identify relationships

Were you able to list reasons?

[LO 2.4]

4.4.5.4 ACTIVITY:**4.4.5.5 To be able to explain and identify food relationships, and to be able to illustrate them using examples****4.4.5.6 [LO 2.1; LO 2.2; LO 2.3; LO 2.4]**

Green plants **photosynthesise** and produce food in the form of starch.

Animals are not capable of producing their own food and therefore need to make use of plants or other animals that have eaten plants.

However, there are different kinds of consumers. In a previous module on biodiversity it was mentioned that herbivores, carnivores and omnivores together comprise the consumers.

Decomposers are also an important part of the chain.

All the above-mentioned are links in a typical **FOOD CHAIN**.

A **food chain** originates when organisms feed off each other, and nutrients, as well as energy from the sun, flow from one organism to the next.

Test your knowledge of food relationships

1. Provide the scientific word for:

1.1 plant-eaters:

1.2 meat-eaters:

1.3 eaters of both plants and meat:

2. Provide the definition of:

2.1 a consumer:

2.2 a producer:

2.3 a food chain:

3. Briefly explain the importance of the following:

3.1 a scavenger:

3.2 decomposers:

4. Name at least TWO important decomposers:

Assessment of **QUESTIONS ON THE FOOD CHAIN**

Were you able to answer the questions correctly?

[LO 2.1]

Compile a food chain

- Compile a simple food chain by pasting sketches or pictures in the proper order.
- In nature food chains do not exist in isolation, in other words they are interlinked. Such a network of food chains is called a **FOOD WEB**.

- Food chains are often represented as FOOD PYRAMIDS. A food pyramid indicates the amount of biomass or energy on each level in the food chain.[LO 2.2]

Assessment of your understanding of the FOOD CHAIN

Were you able to represent both?

[LO 2.3]

Read the following and use the information to compile as many food chains as possible.

It is a hot day in the Kalahari. A light breeze is blowing dead matter in the form of fine twigs and organic material over the top of a sand dune. Insects such as ants and beetles scuttle about in an attempt to pick up some of these bits and pieces. In a little funnel in the sand an ant-lion lies in wait for its prey. As it starts to cool down at nightfall, tiny field-mice and other mammals appear.

They nibble at the last few grass seeds and blades of grass on which the little moisture there is in the air will condense again to form droplets of water in the early hours of the morning. On the crown of the dune a black tapping-beetle scurries along. It comes to a standstill with its tail in the air so that some of the moisture from the soil can condense on its hard little body and run down into its thirsty mouth.

In the heat of the day the gecko makes small two-steps to avoid being scorched by the burning sand. A grasshopper on a tuft of grass catches its attention. Scorpions scuttle about with their tails held high, in search of spiders and beetle larvae. Spiders lie in wait for ants and termites and a horned adder chases after a field-mouse. All of this takes place amid the great silence of the sweltering day and the cold night when the jackal's cries can be heard.

Assessment of the interpretation of the PASSAGE:

Were you able to identify the basic FOOD CHAINS from the passage?

[LO 2.4]

4.4.6 Assessment

LO 2: Constructing Science Knowledge:

The learner will know and be able to interpret and apply scientific, technological and environmental knowledge.

This is evident when the learner:

- recalls meaningful information;
- categorises information;
- interprets information;

2.4 applies knowledge.

4.4.6.1 Memorandum

Activity: Reasons for ecological relationships

Reasons: *food* — e.g. birds that pollinate flowers, animals that serve as prey for other animals, herbivores that eat grass, *protection* — e.g. gnus, zebras and impalas that graze together (protections against predators), *homes* — e.g. birds that nest in a tree, *decomposition* — e.g. fungi and bacteria that depend on dead plants and animals for their food, but in turn are useful to other plants and animals because their action maintains the fertility of the soil.

The most important reason: a **class decision**

Activity: Explaining, identifying and illustrating food-based relationships / the food chain

Tests your knowledge:

- 1.1 – herbivores 1.2 – carnivores 1.3 – omnivores
- 2.

2.1 consumer: not able to produce own food, must eat / live off plants or something else that eats / lives off plants.

2.2 producer: produces its own food by utilising the sun, carbon dioxide and water, e.g. green plants.

2.3 Energy derived from the sun, by means of a range of organisms, usually ranging from a herbivore first, then through a range of consumers to decomposers. Some energy is lost at each link.

3.

3.1 Carrion eaters remove visible animal remains while decomposers see to fine breaking down to mineral level so that the residue can return to the soil.

3.2 Decomposers break down organic material (plant and animal remains) to basic nutrients (nutrients / building materials) that are made available to plants from the soil.

4. Fungi, bacteria (or examples of fungi and bacteria)

The Food chain

- Accept the learner's answer if the following are correct: producer, 1st consumer, 2nd consumer and 3rd consumer, decomposer.

Food chains related to a text for reading

- E.g. twigs / organic material - ants - antlion - gecko - snake
- Grass - locust - gecko - snake
- Twigs / organic material - field mouse - snake

4.5 Special food relationships⁵

4.5.1 NATURAL SCIENCES

4.5.2 Grade 8

4.5.3 ENVIRONMENT AND INTERACTIONS

4.5.4 Module 36

4.5.5 SPECIAL FOOD RELATIONSHIPS

4.5.5.1 ACTIVITY:

4.5.5.2 To be able to identify special food relationships and to be able to describe them from examples

4.5.5.3 [LO 2.4]

Besides the typical predator and prey relationships there are certain relationships that are very interesting and special, especially because they are also linked to survival strategies.

SYMBIOSIS is the co-existence of two different organisms.

This relationship of co-existing can differ with regard to the amount of advantage or disadvantage gained by each party.

⁵This content is available online at <<http://cnx.org/content/m20413/1.1/>>.

4.5.5.4 COMMENSALISM



Figure 4.1

One of the organisms benefits and the other one is not really affected.



Figure 4.2

4.5.5.5 MUTUALISM

- Both organisms benefit.
-



Figure 4.3



Figure 4.4



Figure 4.5

4.5.5.6 PARASITISM

- One organism definitely benefits at the expense of the other one.

Complete the table by pasting one of the sketches from the sketch sheet next to each of the relationships. Paste in some of your own examples as well. Describe the characteristics of the relationship in the right-hand column.

Special Food Relationships

	EXAMPLES	DESCRIPTION OF RELATIONSHIP
Mutualism		
Parasitism		
Commensalism		

Table 4.10

Assessment of CUTTING AND PASTING of SYMBIOSIS SKETCHES

Were you able to identify and describe SYMBIOSIS TYPES correctly?

[LO 2.4]

4.5.5.7 ACTIVITY:

4.5.5.8 To do research on parasitism and to represent the results graphically on a poster

4.5.5.9 [LO 1.1; LO 1.2; LO 1.3]

Work in groups of four and collect examples of the different kinds of parasites that use both humans and animals as hosts.

- Explain the following:
 1. the parasite and the host, and the nature of their relationship
 2. symptoms that can be detected in the host
 3. how to combat the parasite
- Divide the different parts of the assignment among the members of the group so that each one will be responsible for a certain part.
- Remember that plants also have parasites – find out more about this and use at least one plant as an example. Present the poster to the rest of the class.

Assessment of GROUP WORK, RESEARCH AND COMMUNICATION on PARASITES

Were you able to contribute to the group's research work, and communicate it to the rest of the class? **LO 1.1; LO 1.2; LO 1.3**

4.5.6 Assessment

LO 1: Scientific investigations:

The learner will be able to act confidently on curiosity about natural phenomena, and to investigate relationships and solve problems in scientific, technological and environmental contexts.

This is evident when the learner:

- plans investigations;
- conducts investigations and collects data;
- evaluates data and communicates findings.

LO 2: Constructing Science Knowledge:

The learner will know and be able to interpret and apply scientific, technological and environmental knowledge.

This is evident when the learner:

2.4 applies knowledge.

4.5.7 Memorandum

Activity: Special food relationships

Mutualism: bird and flower: The bird obtains food (advantage), flower is pollinated (advantage).

Parasitism: tick on horse: The tick obtains food (advantage), horse loses blood (disadvantage).

Commensalism: Cattle and birds: Cattle dislodge and carry ticks that occur on the grass, providing food for the birds while the cattle remain unaffected.

Sharks and small fish: The fish eat the remains of the food consumed by the sharks while the sharks remain unaffected.

Activity: Researching parasitism

- Assess the learner's attempt in terms of the three assessment standards 1.1 (planning), 1.2 (collecting data), and 1.3 (interpretation and communication).

4.6 Ecotourism⁶

4.6.1 NATURAL SCIENCES

4.6.2 Grade 8

4.6.3 ENVIRONMENT

4.6.4 Module 37

4.6.5 ECO-TOURISM

4.6.5.1 ACTIVITY 1:

4.6.5.2 To be able to explain the value of eco-tourism and to develop a product that can be used to inspire others

4.6.5.3 [LO 1.1; LO 1.2; LO 1.3; LO 3.2]

Ecotourism refers to an industry that encourages tourists to experience and appreciate the country's natural beauty and ecologically pristine areas.

⁶This content is available online at <<http://cnx.org/content/m20300/1.1/>>.

South Africa is the only country on earth in which all the members of a specific plant kingdom are found naturally within its borders. This plant kingdom is the **FYNBOS** of the Western Cape.

It is an area that stretches around the mountains of the Boland, and includes various unique plant species such as the protea (our national flower) and heather. It has the greatest concentration of endemic plant species. **Endemic** means that it does not occur naturally anywhere else.

St Lucia and other marshlands are the birthplace of many species. These areas have a very delicate balance which can easily be disturbed by 4x4 enthusiasts and pleasure boat adventurers.

One reads news articles about these and other sensitive areas all the time. Unfortunately there are constantly reports about insensitive people who do not know how to utilize, appreciate and conserve these precious areas.

Our game parks such as the Kruger National Park, the Kgalagadi, Hluhluwe and Pilanesberg are widely known amongst overseas tourists.

NATURE CONSERVATION is of the utmost importance in all these areas. Strict rules apply and are generally adhered to by considerate tourists.

- Design a colourful brochure that you could give to a tourist from overseas in order to introduce them to the natural beauty of South Africa, and its ecological treasures.
- You may choose one or more topics.
- You will have to research the natural beauty, sensitivity and uniqueness (plants and animals) of a specific environment and incorporate the findings in the brochure.
- Hand the brochure in on the date that has been determined by your teacher.

Alternatively: Compile a video clip or photo album of such a natural area and show it to the class.

Assessment of the BROCHURE: Were you able to PLAN and CONDENSE FACTS in a visual presentation? [LO 1.1; LO 1.2; LO 1.3]

- Now write 270 words on the value of ecotourism. Refer to your research.

[LO 3.2]

4.6.6 Assessment

LO 1: Scientific investigations:

The learner will be able to act confidently on curiosity about natural phenomena, and to investigate relationships and solve problems in scientific, technological and environmental contexts.

This is evident when the learner:

- plans investigations;
- conducts investigations and collects data;
- evaluates data and communicates findings.

LO 3: Science, Society and the Environment

The learner will be able to demonstrate an understanding of the interrelationships between science and technology, society and the environment.

This is evident when the learner:

3.2 understands sustainable use of the earth's resources.

4.6.7 Memorandum

Activity 1: Brochure or video

- Learners are required to design a colourful brochure that could be given to a tourist from abroad to introduce the natural beauty of South Africa as well as the country's ecological treasures. The learner may choose one or two subjects.
- Assess this in conjunction with the paragraph on the value of ecotourism. Note the following:
 - Problem statement (planning)
 - Sources used for information
 - Quality of information (did the learner make a selection or simply accept what was found first?)
 - Layout / presentation / reasoning (communicating).

4.7 Role of water⁷

4.7.1 NATURAL SCIENCES

4.7.2 Grade 8

4.7.3 ENVIRONMENT

4.7.4 Module 38

4.7.5 THE ROLE OF WATER IN NATURE AND ITS ROLE AS A RESOURCE

4.7.5.1 ACTIVITY:

4.7.5.2 To be able to explain the value of water and the water cycle

4.7.5.3 [LO 1.3; LO 2.3; LO 2.4]

Our planet looks blue from outer space because of the water on its surface.

Water is indispensable for life on our planet. Without water ecological survival would not be possible.

Our planet is equipped with a certain quota of water – just as a spaceship would be. The water is not replenished from outer space, but has to **CIRCULATE**. Thus the **WATER CYCLE** is an extremely important aspect of nature. It is also most effective if humans do not disturb it.

The Water Cycle

Draw a representation of the water cycle as you understand it. Use explanatory captions. Use the table on the following page as a guideline.

Assessment of WATER CYCLE SKETCH

Were you able to represent basic components and definitions GRAPHICALLY?

[LO 2.3]

El Niño, droughts and floods

- On comparing the rainfall statistics of South Africa to those of other countries, one sees very clearly that South Africa is an arid country.
- Only some of the larger rivers flow permanently.
- Furthermore, our climate and rainfall patterns are determined by phenomena such as El Niño. This is a world-wide weather phenomenon and precautions must be taken to cope with it.

⁷This content is available online at <<http://cnx.org/content/m20301/1.1/>>.

1. Find out more about **El Niño** and report back to the class. Make a brief summary of your notes.
2. Find articles on droughts and floods in South Africa and bring them to class. Swap information and articles. Make notes on the subject.

[LO 1.3]

Use graph paper and draw two column graphs in different colours to represent the rainfall patterns in the two provinces.

4.7.5.4 ACTIVITY:

4.7.5.5 To look into the value of water and its use in and around the house

4.7.5.6 [LO 2.3; LO 3.2]

Water consumption at home

Ask your parents or guardians for their municipal accounts.

- Write down your domestic water consumption for six months (three summer months and three winter months).

Summer months: 1. 2. 3.

Winter months: 1. 2. 3.

- Do you think that your water consumption is excessive?

Saving water at home

How can your family contribute towards saving water? What can YOU do?

- Make a list of your best suggestions:

Assessment of CLASS DISCUSSION

Were you able to make feasible suggestions concerning WATER CONSERVATION?

[LO 3.2]

4.7.5.7 ACTIVITY:

4.7.5.8 To examine the adaptations of plants and animals with regard to water shortage

4.7.5.9 [LO 1.3; LO 2.3]

Plants:

- In a previous module reference was made to plants that can be classified into three groups, according to their water requirements.

Name the three groups and give an example of each.

- Plants have numerous adaptations and survival strategies, especially with regard to water shortages.
- Xerophyte leaves have been modified to thorns in cases such as the cactus plant groups. Other plants, such as the aloe, about which you had to do a project, store a great deal of water in their fleshy leaves through protein bonding.
- The leaves of mainly xerophytes are thick and fleshy and unpleasant or bitter to the taste to deter animals from eating them. In this way they prevent the plant from being robbed of its valuable moisture.
- The leaves of plants that have been adapted to arid conditions for survival are often sessile (no leafstalk) and they are arranged in such a way that any water that collects on the leaf (e.g. dew) will run down the stem so that the roots can absorb it.

- The leaves of some other plants roll up when it is very dry, so that evaporation is limited. For example, see what the leaves of the maize plant look like when it hasn't rained for a long time.



Figure 4.6

Design your own xerophyte

- Draw a sketch to show the adaptations if you were to do the design.

Assessment of DESIGN

Were you able to DRAW a meaningful DESIGN with logical adaptations? [LO 1.3]

Animals:

With animals, in contrast to plants, both structural modifications and behavioural adaptations are used to survive drought. Most of the adaptations are intended to limit loss of water so that the animal needs to ingest less water to survive. In some cases the animal has developed a mechanism for storing water.

Examples of structural adaptations

- Skin cover
 - Insects and spiders have a plastic or leathery skin cover (external skeleton) that permits no water to penetrate. This limits their need for water to such a degree that the moisture that they ingest with their food is sufficient.
 - Reptiles' skin has also been adapted to limit loss of water to the minimum. In the case of other animals where the skin needs to be moist for other reasons, there are mechanisms that prevent unnecessary loss of water. In the case of frogs, for example, mucous is secreted.
 - Birds have a sebaceous gland at the base of the tail. This gland secretes oil that spreads all over the body and makes the feathers relatively waterproof. (You may have seen your mother removing the little gland from the chicken before cooking it.)
 - In the case of mammals the skin could be adapted to limit water loss to a minimum. For instance, dogs perspire through their tongue and not through their skin. That is why they pant when they are hot.
- Internal adaptations
 - Animals' digestive systems and excretory systems have also been adapted to regulate water loss. In the colon, for example, much of the water that is still present in food residues in the body, is absorbed before defecation takes place. The kidneys determine how much water should be allowed to pass to the bladder before it is excreted.
 - Camels have been specially adapted to survive for long periods without ingesting water: water is stored in the hump in the form of a chemical compound and can be released when necessary.

Examples of behavioural patterns

- The evaporation of water is a common cooling mechanism in animals. Humans, for example, must be able to perspire so that the evaporating perspiration can prevent rapid rising of body temperature, whether it be as a result of heat or of heavy exercise. Animals often demonstrate behavioural patterns through which the body is kept cool so that cooling down through other mechanisms, e.g. perspiring, is not necessary. For instance, they might seek out a shady area, dig tunnels, lie under the sand, be inactive during the day or even migrate or hibernate in summer.

4.7.5.10 Assignment:

Read up more on this subject and describe FIVE more ways in which plants prevent water loss and FIVE ways in which animals prevent water loss.

4.7.6 Assessment

LO 1: Scientific investigations:

The learner will be able to act confidently on curiosity about natural phenomena, and to investigate relationships and solve problems in scientific, technological and environmental contexts.

This is evident when the learner:

- evaluates data and communicates findings.

LO 2: Constructing Science Knowledge:

The learner will know and be able to interpret and apply scientific, technological and environmental knowledge.

This is evident when the learner:

- interprets information;

2.4 applies knowledge.

LO 3: Science, Society and the Environment

The learner will be able to demonstrate an understanding of the interrelationships between science and technology, society and the environment.

This is evident when the learner:

3.2 understands sustainable use of the earth's resources.

4.7.7 Memorandum

Activity: The value of water and the water cycle

Own representation of the water cycle:

Check to ensure that the learner has included all the relevant terms in the table in his / her sketch.

El Niño, droughts and floods

1. Help the class to select and record the best information from the learners' feedback / presentations.
2. As in 1.

Activity: Water in and around the home

Learners collect information about water consumption. Encourage them to give their own opinions on the level of their personal consumption of water.

Water Conservation at home

- How might your family be able to contribute towards water conservation?
- Draw up a list of the best suggestions.

- Let the class decide on the best suggestions in the list. Praise the learner whose list resembles this list most closely.

Activity: Adaptations to water shortage that occur among plants and animals

Three groups, with examples: mesophytes (any example), xerophytes (e.g. the aloe, other succulents, prickly pears, etc.), hydrophytes (water lily, etc.)

Design: Note fleshy leaves, frequently small and sessile, arranged in such a way that they lead water towards the stem of the plant. Leaves may also be extremely small and thorn-like. May be covered with a waxy layer. Shallow roots, excessively branched.

Assignment:

- Examples (accept whatever is significant):
- Plants
 - Hairy leaves
 - Few openings (stomata)
 - Openings occurring on lower sides of leaves only
 - Fleshy stems and roots
 - Enlarged underground parts in which water can be stored
- Animals
 - Small body surface
 - Little or no excretion of urine
 - Dry excrement
 - Few blood vessels near the skin in large areas of the body (Because of this, the body cannot be cooled properly and other mechanisms are developed for cooling specific areas, e.g. the brain. In the case of the Cape oryx, for instance, blood that goes to the brain is circulated through the nostrils where it can be cooled down.)
 - Eating food with a high moisture content

Acquaint the learners with the following concepts:

Panting: fast breathing with high loss of moisture from the mucous membranes of the throat and mouth, as in the case of dogs and some bird species

Estivation: passing the summer in a dormant condition. It is cooler below the surface of the soil – this is why some animals use tunnels.

Migration: Birds, in particular, as well as some antelope species, migrate to areas that offer better sources of food, even seasonally, e.g. swallows.

Rete mirabilis: A **miraculous network** of blood vessels in the nostrils of the Cape oryx for cooling the blood.

Survival strategies of animals

- Oryx: shade of trees, and keeping the brain cool by circulating blood through the nostrils.
- Mongoose: shelters underground.
- Migrating to where there is water, no respiration through the skin – no moisture is lost, but cooling down by flying.
- Perspiring through the tongue only.

4.8 Ecological problems⁸

4.8.1 NATURAL SCIENCES

4.8.2 Grade 8

4.8.3 ENVIRONMENT

4.8.4 Module 38

4.8.5 ECOLOGICAL PROBLEMS AND SOLUTIONS

Many of the difficulties that are presently being experienced in nature are caused by humans.

The major problems stem from what is known as the **HIPPO** dilemma.

H - Habitat loss

I - Invader species

P - Pollution

P - Population growth

O - Over-population

4.8.5.1 ACTIVITY 1:

4.8.5.2 To realise what man's role in ecological problems is, and to attempt to find solutions

Man is guilty of all five of these indiscretions. We **deforest** and simply destroy forests because we want to build roads, houses and industries. Just think of the Amazon: there has been a terrific **loss of plants** that have to contribute to our oxygen supply in the air.

We allow foreign species, especially plants and insects, to invade areas where they have no natural enemies and thus present major dangers for the indigenous species which are easily crowded out by the aggressive foreign species. Prime examples of this problem are the rooikrans trees on the Cape Flats or the black wattle trees along the rivers in the Boland.

Foreign bees are also a threat to our indigenous bees.

Pollution is obviously one of the most serious problems. We pollute the air, the soil and the water with chemicals, oil, plastic, other materials that are not bio-degradable, and also with noise.

All of this is made worse because the population is increasing by the day. (This has already been dealt with in the module on Biodiversity.)

The massive increase in population also causes **over-utilization** of all natural resources. The resource that is the most limited is naturally **WATER**.

Prepare a three-minute speech on the following topic: "Man is not part of an ecosystem, and as soon as he becomes involved in an ecosystem, he disturbs the system."

4.8.5.3 ACTIVITY 2:

4.8.5.4 The following project focuses on the meaningful utilization of water as one of our most important natural resources

Project: WATER AUDIT AT SCHOOL

Divide into groups of four. Plan the following:

1. how you are going to determine the water consumption at your school;
2. how you are going to present the findings in a report;
3. which possible cases of water wastage you will be investigating;
4. which recommendations you will make.

⁸This content is available online at <<http://cnx.org/content/m20305/1.1/>>.

- Your teacher will fix a date for the submission of the report.
- Each group will present its report to the class.
- A summary of the final findings can be submitted to school management. A class discussion on the recommendations that are to be submitted would be valuable.

- It would be useful to examine the following as part of the research assignment:

1. Wasting water at taps

You can determine the water consumption of the average learner by following these steps:

Divide into groups of four. You will need a large measuring cylinder, a stopwatch and a bucket.

One person in the group is the time-keeper.

Two people drink.

One person notes down the observations in a table.

When the stopwatch starts running, open the tap normally and drink, using your hand as you would normally do. In the bucket, catch up the water that runs off. The time-keeper will tell you to stop after 30 seconds. One person now pours the wasted water into the measuring cylinder and measures how much water has gone to waste. Repeat the procedure for the second person and find an average.

Person 1:

ml wasted in 30 seconds

Person 2:

ml wasted in 30 seconds

AVERAGE:

Report back to the class. The teacher can write each group's average on the board.

2. Diseases that can be related to the use of water

Divide the class into three groups.

Each group investigates one of the following with regard to the three most important diseases, namely cholera, bilharzia and diarrhoea:

a) causes of the disease;

b) symptoms;

c) treatment;

d) prevention of its spreading.

Finally, write a few sentences to summarize your conclusions with regard to water consumption, saving and conservation.

Assessment of RESEARCH PROJECT – WATER AUDIT

Were you able to PLAN and EXECUTE the project? Can you express your appreciation of water as a valuable resource? [LO 1.1; LO 1.2; LO 1.3; LO 3.1; LO 3.2]

4.8.5.5 ACTIVITY 3:

4.8.5.6 To be able to discuss the problem of pollution

4.8.5.7 [LO 2.2 LO 2.3]

Did you know?

POLLUTION happens in various ways. Make a list.

Identify and describe the pollution that is suggested by each of the following sketches:



Figure 4.7



Figure 4.8



Figure 4.9



Figure 4.10



Figure 4.11



Figure 4.12

Assessment: EXAMPLES OF POLLUTION

Were you able to identify and discuss the examples of pollution? [LO 2.2; LO2.3]

4.8.5.8 ACTIVITY 4:

4.8.5.9 To be able to discuss recycling as a measure to avoid pollution

4.8.5.10 [LO 3.1, LO 3.2]

Think of as many examples as possible where material should be recycled. Present your ideas to the class. Listen to other ideas and write down the five that you consider to be best.

My ideas:

The FIVE best ideas from the class discussion:

How can the community be made aware of the ideas?

Man has the brain power and the technology to put an end to the worst mistakes that have been made in the past. However, it will need a combined effort – where we are all involved – to find solutions to all the problems. Once solutions have been found, we will have to engage in the long and challenging process of sustaining our efforts. It is our duty and responsibility to ensure that generations to come will inherit a healthy planet.

Therefore: think twice before you throw that piece of paper out of the window of the car, or if complain when your school announces a recycling programme.

Assessment of RECYCLING

Were you able to understand that man must continue his attempts at protecting his natural resources? [LO 3.1, 3.2]

4.8.6 Assessment

LO 1: Scientific investigations:

The learner will be able to act confidently on curiosity about natural phenomena, and to investigate relationships and solve problems in scientific, technological and environmental contexts.

This is evident when the learner:

- plans investigations;
- conducts investigations and collects data;
- evaluates data and communicates findings.

LO 2: Constructing Science Knowledge:

The learner will know and be able to interpret and apply scientific, technological and environmental knowledge.

This is evident when the learner:

- categorises information;
- interprets information.

LO 3: Science, Society and the Environment

The learner will be able to demonstrate an understanding of the interrelationships between science and technology, society and the environment.

This is evident when the learner:

- 3.1 understands science as a human endeavour;
- 3.2 understands sustainable use of the earth's resources.

4.8.7 Memorandum

Activity 1: Ecological problems and solutions

PROJECT: WATER AUDIT AT THE SCHOOL

- Form groups of 4. Plan the following:

1. How to determine water consumption at the school.
2. Determining how to represent the findings in a report.
3. The recommendations to be made.

Hand the completed report and findings to the teacher on the predetermined date.

Report-back by Groups. Final findings may be passed on to the school's management body.

Own memorandum

Assignment 1: WATER WASTAGE AT TAPS

- Own memorandum

Assignment 2: CLASS DISCUSSION ON RECOMMENDATIONS

- Which recommendations dealing with water wastage at taps would you hand in together with the water audit that you submit to the school's governing body?
- List of recommendations:
- Own memorandum

Assignment: DISEASES LINKED TO WATER

POLLUTION occurs in various forms. Compile a list:

Oil, chemicals dumped by industry; plastic, car tyres, paper and rubbish littering; water and toxic substances; spraying of insecticides,

Assignment 4: IDENTIFYING INSTANCES OF POLLUTION in an illustration:

- Memorandum for the illustration

Assignment 5: POSTER ON POLLUTION

- Own memorandum

Assignment 6: SUGGESTIONS FOR RECYCLING

- Own memorandum

Attributions

Collection: *Natural Sciences Grade 8*

Edited by: Siyavula Uploaders

URL: <http://cnx.org/content/col11050/1.1/>

License: <http://creativecommons.org/licenses/by/3.0/>

Module: "Energy to begin"

By: Siyavula Uploaders

URL: <http://cnx.org/content/m19990/1.1/>

Pages: 1-2

Copyright: Siyavula Uploaders

License: <http://creativecommons.org/licenses/by/3.0/>

Module: "Present energy sources"

By: Siyavula Uploaders

URL: <http://cnx.org/content/m19991/1.1/>

Pages: 3-5

Copyright: Siyavula Uploaders

License: <http://creativecommons.org/licenses/by/3.0/>

Module: "Hydroelectricity"

By: Siyavula Uploaders

URL: <http://cnx.org/content/m19992/1.1/>

Pages: 5-7

Copyright: Siyavula Uploaders

License: <http://creativecommons.org/licenses/by/3.0/>

Module: "Nuclear power"

By: Siyavula Uploaders

URL: <http://cnx.org/content/m19994/1.1/>

Pages: 7-10

Copyright: Siyavula Uploaders

License: <http://creativecommons.org/licenses/by/3.0/>

Module: "Future energy sources"

By: Siyavula Uploaders

URL: <http://cnx.org/content/m19998/1.1/>

Pages: 10-12

Copyright: Siyavula Uploaders

License: <http://creativecommons.org/licenses/by/3.0/>

Module: "Electricity"

By: Siyavula Uploaders

URL: <http://cnx.org/content/m20014/1.1/>

Pages: 12-15

Copyright: Siyavula Uploaders

License: <http://creativecommons.org/licenses/by/3.0/>

Module: "Electric Circuits"
By: Siyavula Uploaders
URL: <http://cnx.org/content/m20017/1.1/>
Pages: 15-20
Copyright: Siyavula Uploaders
License: <http://creativecommons.org/licenses/by/3.0/>

Module: "Vocabulary for electricity"
By: Siyavula Uploaders
URL: <http://cnx.org/content/m31826/1.1/>
Pages: 21-24
Copyright: Siyavula Uploaders
License: <http://creativecommons.org/licenses/by/3.0/>

Module: "Units of electricity"
By: Siyavula Uploaders
URL: <http://cnx.org/content/m20020/1.1/>
Pages: 24-28
Copyright: Siyavula Uploaders
License: <http://creativecommons.org/licenses/by/3.0/>

Module: "Heat and temperature"
By: Siyavula Uploaders
URL: <http://cnx.org/content/m20027/1.1/>
Pages: 28-32
Copyright: Siyavula Uploaders
License: <http://creativecommons.org/licenses/by/3.0/>

Module: "Reflection and refraction of light"
By: Siyavula Uploaders
URL: <http://cnx.org/content/m20029/1.1/>
Pages: 32-42
Copyright: Siyavula Uploaders
License: <http://creativecommons.org/licenses/by/3.0/>

Module: "Refraction of white light"
By: Siyavula Uploaders
URL: <http://cnx.org/content/m20030/1.1/>
Pages: 42-45
Copyright: Siyavula Uploaders
License: <http://creativecommons.org/licenses/by/3.0/>

Module: "What is everything"
By: Siyavula Uploaders
URL: <http://cnx.org/content/m20233/1.1/>
Pages: 47-48
Copyright: Siyavula Uploaders
License: <http://creativecommons.org/licenses/by/3.0/>

Module: "Building blocks of matter"
By: Siyavula Uploaders
URL: <http://cnx.org/content/m20236/1.1/>
Pages: 48-50
Copyright: Siyavula Uploaders
License: <http://creativecommons.org/licenses/by/3.0/>

Module: "Phase changes of matter"
By: Siyavula Uploaders
URL: <http://cnx.org/content/m20238/1.1/>
Pages: 50-54
Copyright: Siyavula Uploaders
License: <http://creativecommons.org/licenses/by/3.0/>

Module: "Crystals and solutions"
By: Siyavula Uploaders
URL: <http://cnx.org/content/m20244/1.1/>
Pages: 54-57
Copyright: Siyavula Uploaders
License: <http://creativecommons.org/licenses/by/3.0/>

Module: "Atoms"
By: Siyavula Uploaders
URL: <http://cnx.org/content/m20250/1.1/>
Pages: 57-59
Copyright: Siyavula Uploaders
License: <http://creativecommons.org/licenses/by/3.0/>

Module: "Molecules"
By: Siyavula Uploaders
URL: <http://cnx.org/content/m31830/1.1/>
Pages: 59-61
Copyright: Siyavula Uploaders
License: <http://creativecommons.org/licenses/by/3.0/>

Module: "Elements and compounds"
By: Siyavula Uploaders
URL: <http://cnx.org/content/m31829/1.1/>
Pages: 61-74
Copyright: Siyavula Uploaders
License: <http://creativecommons.org/licenses/by/3.0/>

Module: "Metals and non-metals"
By: Siyavula Uploaders
URL: <http://cnx.org/content/m20263/1.1/>
Pages: 75-76
Copyright: Siyavula Uploaders
License: <http://creativecommons.org/licenses/by/3.0/>

Module: "Compounds and mixtures"
By: Siyavula Uploaders
URL: <http://cnx.org/content/m20269/1.1/>
Pages: 77-79
Copyright: Siyavula Uploaders
License: <http://creativecommons.org/licenses/by/3.0/>

Module: "Separation of mixtures"
By: Siyavula Uploaders
URL: <http://cnx.org/content/m20271/1.1/>
Pages: 79-81
Copyright: Siyavula Uploaders
License: <http://creativecommons.org/licenses/by/3.0/>

Module: "Prehistoric life"
 By: Siyavula Uploaders
 URL: <http://cnx.org/content/m20274/1.1/>
 Pages: 83-84
 Copyright: Siyavula Uploaders
 License: <http://creativecommons.org/licenses/by/3.0/>

Module: "Fossils"
 By: Siyavula Uploaders
 URL: <http://cnx.org/content/m20280/1.1/>
 Pages: 84-89
 Copyright: Siyavula Uploaders
 License: <http://creativecommons.org/licenses/by/3.0/>

Module: "Life on earth"
 By: Siyavula Uploaders
 URL: <http://cnx.org/content/m20287/1.1/>
 Pages: 89-92
 Copyright: Siyavula Uploaders
 License: <http://creativecommons.org/licenses/by/3.0/>

Module: "Survival: habitat"
 By: Siyavula Uploaders
 URL: <http://cnx.org/content/m20288/1.1/>
 Pages: 93-96
 Copyright: Siyavula Uploaders
 License: <http://creativecommons.org/licenses/by/3.0/>

Module: "Anamals are adapted"
 By: Siyavula Uploaders
 URL: <http://cnx.org/content/m20290/1.1/>
 Pages: 97-101
 Copyright: Siyavula Uploaders
 License: <http://creativecommons.org/licenses/by/3.0/>

Module: "Plant adaptations"
 By: Siyavula Uploaders
 URL: <http://cnx.org/content/m20296/1.1/>
 Pages: 101-105
 Copyright: Siyavula Uploaders
 License: <http://creativecommons.org/licenses/by/3.0/>

Module: "Sustainability"
 By: Siyavula Uploaders
 URL: <http://cnx.org/content/m20297/1.1/>
 Pages: 105-107
 Copyright: Siyavula Uploaders
 License: <http://creativecommons.org/licenses/by/3.0/>

Module: "Sustainable activities"
 By: Siyavula Uploaders
 URL: <http://cnx.org/content/m20298/1.1/>
 Pages: 107-109
 Copyright: Siyavula Uploaders
 License: <http://creativecommons.org/licenses/by/3.0/>

Module: "World population"
By: Siyavula Uploaders
URL: <http://cnx.org/content/m20299/1.1/>
Pages: 109-110
Copyright: Siyavula Uploaders
License: <http://creativecommons.org/licenses/by/3.0/>

Module: "The ecosystem"
By: Siyavula Uploaders
URL: <http://cnx.org/content/m20408/1.1/>
Pages: 111-115
Copyright: Siyavula Uploaders
License: <http://creativecommons.org/licenses/by/3.0/>

Module: "Different ecosystems"
By: Siyavula Uploaders
URL: <http://cnx.org/content/m20409/1.1/>
Pages: 115-118
Copyright: Siyavula Uploaders
License: <http://creativecommons.org/licenses/by/3.0/>

Module: "The role of plants in an ecosystem"
By: Siyavula Uploaders
URL: <http://cnx.org/content/m20410/1.1/>
Pages: 119-122
Copyright: Siyavula Uploaders
License: <http://creativecommons.org/licenses/by/3.0/>

Module: "Ecological relationships"
By: Siyavula Uploaders
URL: <http://cnx.org/content/m20411/1.1/>
Pages: 122-125
Copyright: Siyavula Uploaders
License: <http://creativecommons.org/licenses/by/3.0/>

Module: "Special food relationships"
By: Siyavula Uploaders
URL: <http://cnx.org/content/m20413/1.1/>
Pages: 125-128
Copyright: Siyavula Uploaders
License: <http://creativecommons.org/licenses/by/3.0/>

Module: "Ecotourism"
By: Siyavula Uploaders
URL: <http://cnx.org/content/m20300/1.1/>
Pages: 128-130
Copyright: Siyavula Uploaders
License: <http://creativecommons.org/licenses/by/3.0/>

Module: "Role of water"
By: Siyavula Uploaders
URL: <http://cnx.org/content/m20301/1.1/>
Pages: 130-134
Copyright: Siyavula Uploaders
License: <http://creativecommons.org/licenses/by/3.0/>

ATTRIBUTIONS

145

Module: "Ecologicalproblems"

By: Siyavula Uploaders

URL: <http://cnx.org/content/m20305/1.1/>

Pages: 135-139

Copyright: Siyavula Uploaders

License: <http://creativecommons.org/licenses/by/3.0/>

About Connexions

Since 1999, Connexions has been pioneering a global system where anyone can create course materials and make them fully accessible and easily reusable free of charge. We are a Web-based authoring, teaching and learning environment open to anyone interested in education, including students, teachers, professors and lifelong learners. We connect ideas and facilitate educational communities.

Connexions's modular, interactive courses are in use worldwide by universities, community colleges, K-12 schools, distance learners, and lifelong learners. Connexions materials are in many languages, including English, Spanish, Chinese, Japanese, Italian, Vietnamese, French, Portuguese, and Thai. Connexions is part of an exciting new information distribution system that allows for **Print on Demand Books**. Connexions has partnered with innovative on-demand publisher QOOP to accelerate the delivery of printed course materials and textbooks into classrooms worldwide at lower prices than traditional academic publishers.