

**SHARP®**



**ELECTRONIC PRINTING CALCULATOR**

**OPERATION MANUAL**

CONTROLS AND OPERATIONS.....5  
CALCULATION EXAMPLES.....24

**WARNING – FCC Regulations state that any unauthorized changes or modifications to this equipment not expressly approved by the manufacturer could void the user's authority to operate this equipment.**

Note: This equipment has been tested and found to comply with the limits for a Class B digital device, pursuant to Part 15 of the FCC Rules. These limits are designed to provide reasonable protection against harmful interference in a residential installation. This equipment generates, uses, and can radiate radio frequency energy and, if not installed and used in accordance with the instructions, may cause harmful interference to radio communications. However, there is no guarantee that interference will not occur in a particular installation. If this equipment does cause harmful interference to radio or television reception, which can be determined by turning the equipment off and on, the user is encouraged to try to correct the interference by one or more of the following measures:

- Reorient or relocate the receiving antenna.
- Increase the separation between the equipment and receiver.
- Connect the equipment into an outlet on a circuit different from that to which the receiver is connected.
- Consult the dealer or an experienced radio/TV technician for help.

## Table of Contents

<b>Operational Notes</b> .....	<b>5</b>
<b>Using the Calculator for the First Time</b> .....	<b>6</b>
Removing the Insulation Sheet and Resetting .....	6
Adjusting the Date and Time .....	7
<b>Operating Controls</b> .....	<b>8</b>
Power Switch/ Print/ Item Count Mode Selector .....	8
Decimal Selector .....	9
Constant/ Add Mode Selector .....	9
Rounding Selector .....	10
Grand Total/ Rate Setting Mode Selector .....	10
Set Date .....	10
Set Time .....	11
Set Conversion Rate .....	11
Set Tax/ Discount Rate .....	11
Overview of Keys .....	12
Time Calculation Key .....	12
Clock Calendar Key .....	12
Non-Add/Subtotal Key .....	13
Average Key .....	14
Multiplication Rate Conversion Key .....	14
Division Rate Conversion Key .....	15
<b>Ink Ribbon Replacement</b> .....	<b>16</b>
<b>Paper Roll Replacement</b> .....	<b>17</b>
<b>Errors</b> .....	<b>18</b>
Error Conditions .....	18
<b>Battery Replacement</b> .....	<b>19</b>
Time for Battery Replacement .....	19
Method of Battery Replacement .....	19
After Battery Replacement .....	20
Precautions on Battery Use .....	20
<b>Specifications</b> .....	<b>21</b>

<b>Resetting the Unit .....</b>	<b>23</b>
<b>Calculation Examples .....</b>	<b>24</b>
General Instructions.....	24
Printing Date/Time.....	24
Time Calculations .....	25
Mixed Calculations.....	26
Constant Calculations.....	27
Addition and Subtraction with Add Mode .....	28
Correction of Errors.....	29
Percent .....	30
Percent Change .....	30
Markup and Margin .....	31
Grand Total .....	32
Memory.....	33
Item Count Calculation .....	34
Add-on and Discount .....	35
Averaging .....	36
Tax Rate Calculations .....	37
Conversion Calculator .....	38
<b>Warranty.....</b>	<b>41</b>

## OPERATIONAL NOTES

To insure trouble-free operation of your SHARP calculator, we recommend the following:

1. The calculator should be kept in areas free from extreme temperature changes, moisture, and dust.
2. A soft, dry cloth should be used to clean the calculator. Do not use solvents or a wet cloth.
3. Since this product is not waterproof, do not use it or store it where fluids, for example water, can splash onto it. Raindrops, water spray, juice, coffee, steam, perspiration, etc. will also cause malfunction.
4. If service should be required, use only a SHARP servicing dealer, a SHARP approved service facility or SHARP repair service.
5. Do not operate the unit with the battery insulation sheet attached. The battery insulation sheet prevents the memory protection battery from wearing, and is found on the back of the unit. Operating with the battery insulation sheet attached may result to loss of information such as date and time, conversion rate, and tax/discount rate if the AC power plug is accidentally pulled out from the wall socket.
6. Do not wind the AC cord around the body or otherwise forcibly bend or twist it.

SHARP will not be liable nor responsible for any incidental or consequential economic or property damage caused by misuse and/or malfunctions of this product and its peripherals, unless such liability is acknowledged by law.

## USING THE CALCULATOR FOR THE FIRST TIME

First, pull out the insulation sheet for the memory protection battery (installed for retaining the date/time, conversion rate, and tax/discount rate information). Reset the calculator to initialize the unit's state, then adjust the date and time.

### Removing the insulation sheet, and resetting



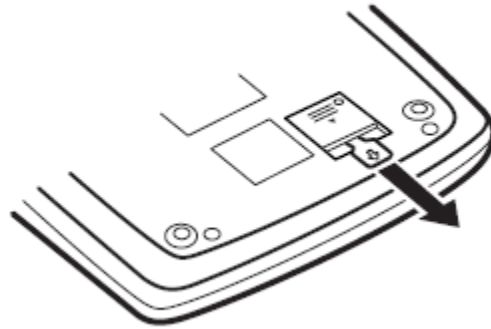

1. Pull out the insulation sheet for the memory protection battery.



2. Press the RESET switch located on the back of the unit.  
(See "RESETTING THE UNIT".)  
\* The clock starts, indicating the current date and time as January 1, 2005, 12:00:00 a.m.

## Adjusting date and time

Example: When the date is September 15, 2004, and the time is 3:38 p.m.

Operation	Display
	
9 [.] 15 [.] 2004 	9-15-2004
15 [.] 38 	3-38 00 P
	0.

(see "GRAND TOTAL / RATESETTING MODE SELECTOR")

\* When the adjustment is complete, the clock starts at 3:38:00 p.m.

# OPERATING CONTROLS

## Power Switch/ Print/ Item Count Mode Selector

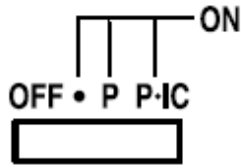

**POWER SWITCH; PRINT / ITEM COUNT MODE SELECTOR:**

“OFF”: Power off.









“□”: Power ON. Set to the non-print mode.

“P”: Power ON. Set to the print mode.



“P•IC”: Power ON. Set to the print and item count mode.

1. The counter will count the number of times that the  key has been pressed in addition.

Note:

- Each time the  key is used in subtraction, 1 will be subtracted from the count.
  - The count is printed when the calculated result is obtained.
  - Pressing of the , , ,  or  key clears the counter.
2. When the grand total/rate setting mode selector is in the ON position (GT), the counter will count the number of times that the calculation results have been stored in the grand total memory. To print and clear the count, press the  key.
  3. The memory item counter will count the number of times that the  key has been pressed in the addition.

Note:

- Each time the  key is used in the subtraction, 1 will be subtracted from the count.
- The count is printed when the memory is recalled.
- Pressing of the  key clears the counter.



Note: The counter has a maximum capacity of 3 digits (up to  $\pm 999$ ). If the count exceeds the maximum, the counter will recount from zero.

Decimal Selector

**F 6 3 2 1 0**

**DECIMAL SELECTOR:**

Presets the number of decimal places in the answer. In the “F” position, the answer is displayed in the floating decimal system.

Constant/ Add Mode Selector

**K • A**

**CONSTANT/ADD MODE SELECTOR:**

“K”: The following constant functions will be performed:

**Multiplication:**

The calculator will automatically remember the first number

entered (the multiplicand) and  instruction.

**Division:**

The calculator will automatically remember the second number

entered (the divisor) and  instruction.

“●”: Neutral

“A”: Use of the Add mode permits addition and subtraction of numbers without an entry of the decimal point. When the Add mode is activated, the decimal point is automatically positioned according to the decimal selector setting.

Use of  ,  and  will automatically override the Add mode and decimally correct answers will be printed at the preset decimal position.

## Rounding Selector

↑ 5/4 ↓

**ROUNDING SELECTOR:**

“↑”: An answer is rounded up.

“5/4”: An answer is rounded off.

“↓”: An answer is rounded down.

Note: The decimal point floats during successive calculation by the use of  or .

If the decimal selector is set to “F” then the answer is always rounded down (↓).

## Grand Total/ Rate Setting Mode Selector

RATE  
GT • SET

**GRAND TOTAL/RATE SETTING MODE SELECTOR:**

“GT”: Grand Total

“●”: Neutral

“<sup>RATE</sup>SET ”: To set up date, time, conversion rate, and tax/discount rate, place the switch at the "RATE SET" position.

### Date:

- Enter in the order of month, day and year, then press



to complete the entry.

- Use  to separate month, day, and year.



- When  is pressed, the number entered is evaluated and displayed as “date” if the value is within the following range; “Error” is displayed otherwise, and the previously set date is restored.

Month: 1 - 12; day: 1 - 31; Year: 2000 - 2099 (in 4 digits) or 00 - 99 (in 2 digits)





## Time:

- Enter in the order of hour, minutes, then press  to complete the entry.  
(There is no entry available for the seconds' value. The clock starts at zero second.)
- If the hour/minute digit is less than 10, it is not necessary to enter the first digit "0".
- Use  to separate hour and minute values.
- When  is pressed, the number entered is evaluated and displayed as "time" if the value is within the following range; "Error" is displayed otherwise, and the previously set time is restored.  
Hour: 0 - 23 (24-hour system for the hour entry),  
Minute: 0 – 59

## Conversion rate:

- Press  twice, enter the conversion rate, followed by .
- A maximum of 6 digits can be stored (decimal point is not counted as a digit).

## Tax / discount rate:

- Press  twice, enter the tax rate, followed by .
- Press  twice, enter the discount rate, followed by  then .
- A maximum of 4 digits can be stored (decimal point is not counted as a digit).

## Note:

- Be sure to set this selector to the "□" position after storing an each rate.
- For the conversion rate and the tax / discount rate, a single value can be stored for each. If you enter a new rate, the previous rate will be cleared.

## Overview of Keys

### Time Calculation Key

















#### **TIME CALCULATION KEY:**

- Utilize this key to enter hours and minutes in time calculations.
- Press this key after entering an hour or minute value. (There is no need to press this key when entering a second value.)
- To bypass hour entry, press this key after entering 0.
- To bypass minute entry, you may press this key alone, or press it after entering 0.
- When this key is pressed, if the preceding entry is in any of the following ranges, it is set as an hour or minute value:  
Hour: Within 6 digits  
Minute: 0 to 99 (An entry above 60 is rounded up to one hour. If a value of more than 3 digits is entered, only the least significant two digits take effect.)
- A second value is set when it is entered in the following range:  
Second: 0 to 99 (An entry above 60 is rounded up to one minute. If a value of more than 3 digits is entered, only the least significant two digits take effect.)





#### **CLOCK / CALENDAR KEY:**

- Each time this key is pressed, the mode switches.  
Calculation mode → Date display mode → Clock display mode → Calculation mode
- Use this key also to adjust date and time (see “GRAND TOTAL / RATE SETTING MODE SELECTOR”).

	PAPER FEED KEY
	LAST DIGIT CORRECTION KEY
	GRAND TOTAL KEY
	CLEAR ENTRY KEY
	TOTAL KEY:
	MULTIPLICATION KEY
	DIVISION KEY
	MINUS EQUAL KEY
	PLUS EQUAL KEY
	CHANGE SIGN KEY
	MARKUP KEY
	MEMORY TOTAL CLEAR KEY
	MEMORY SUBTOTAL RECALL KEY
	MEMORY PLUS KEY
	MEMORY MINUS KEY
	TAX-INCLUDING KEY
	PRE-TAX KEY
	PERCENT KEY
	NON-ADD/SUBTOTAL KEY:

**Non-add** – When this key is pressed right after an entry of a number in the Print mode, the entry is printed on the left-hand side with the symbol “#”. This key is used to print out numbers not subjects to calculation such as code, date, etc.

**Subtotal** – Used to get subtotal(s) of additions and/or subtractions. When pressed following the  or  key, the subtotal is printed with the symbol “◆” and the calculation may be continued.

**By pressing this key even in the Non-print mode, the displayed number is printed with the symbol “P”.**

- When the POWER SWITCH; PRINT / ITEM COUNT MODE SELECTOR is set “•”, “P” or “P•IC” position, and Date or Clock is displayed, press this key to print the displayed contents, including “#” symbol, from the left side of the paper roll.

Example:

Date printing

#9 • 15 • 2004 • • • • •

(When the date is September 15, 2004)

Clock printing

#10 • 30 • • • • • • • • • A

(When the time is 10:30 a.m.)

#6 • 25 - - - - - P

(When the time is 6:25 p.m.)

- When the Date / Clock printing is complete, the Calculation mode is restored.

 **AVERAGE KEY:**

Used to calculate the average.

 **CONVERSION KEY:**

This key is used:

- To store the conversion rate (by the use of the rate setting mode selector).
- Obtains a value by multiplying a given number with a specified conversion rate.

- To recall the presently stored rate for check. Press  $\boxed{*}$   $\boxed{*}$  first to clear the calculation register and reset an error condition, then press  $\boxed{\times\text{RATE}}$ . The conversion rate is printed with the symbol “TC”.

### $\boxed{\div\text{RATE}}$ CONVERSION KEY:

This key is used to obtain a value by dividing a given number with a specified conversion rate.

### DISPLAY SYMBOLS:

**M** : A number has been stored in memory.

**–** : The display value is negative.

**E** : Error or overflow of capacity.

- : Appears when a number is in the grand total memory.

## INK RIBBON REPLACEMENT

1. Remove the paper roll from the calculator. (Tear the paper and remove it from the print mechanism by using .)
2. **Turn the power off before replacing ribbon.**
3. Remove the printer cover. (Fig. 1)
4. Remove the old ribbon by pulling it up.
5. Insert the new ribbon.
6. With the black side of the ribbon facing upwards, place one of the reels on the reel shaft on the right. (Fig. 2) Make sure that the reel is securely in place.
7. Thread the ribbon around the outside of the metal guides. (Fig. 3)
8. Take up any slack by manually turning one of the reels.
9. Replace the printer cover. (fig 4)
10. Replace the paper roll.

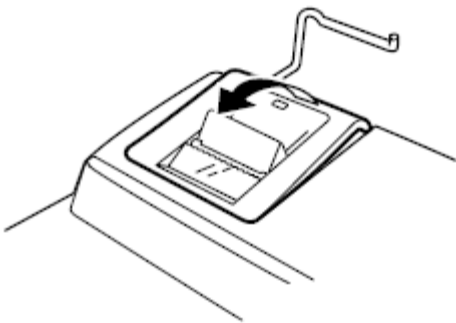

Fig. 1

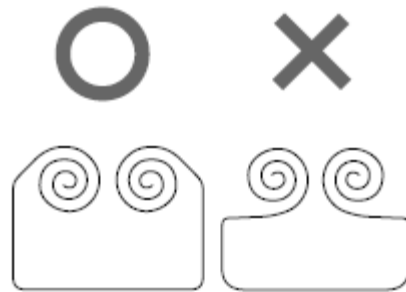

Fig. 2

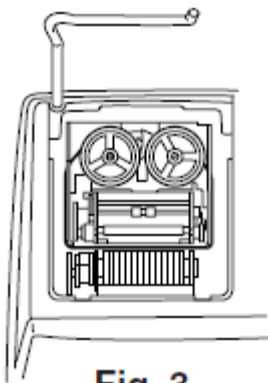

Fig. 3

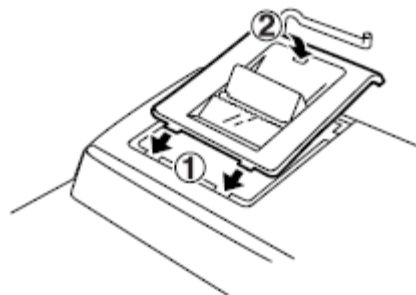



Fig. 4



## PAPER ROLL REPLACEMENT

Never insert paper roll if torn. Doing so will cause paper to jam.

Always cut leading edge with scissors first.

1. Insert the leading edge of the paper roll into the opening. (Fig.1)
2. Turn the power on and feed the paper by pressing . (Fig. 2)
3. Insert the paper roll to the paper holder. (Fig. 3)

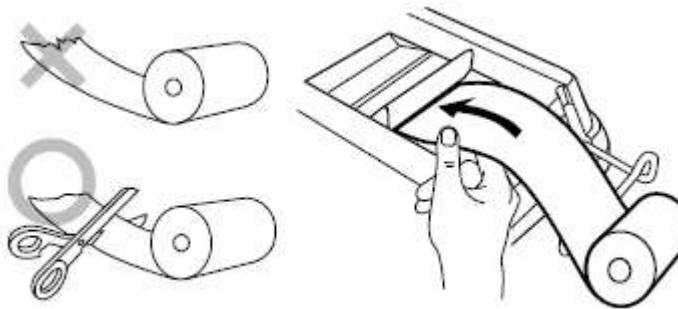

Fig. 1

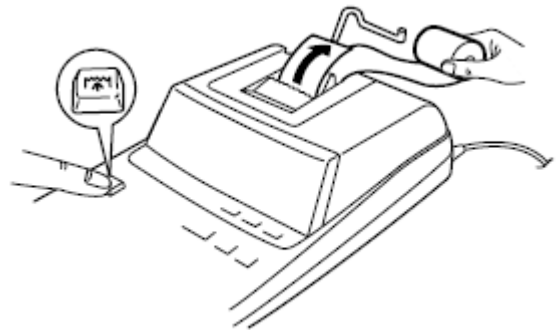

Fig. 2

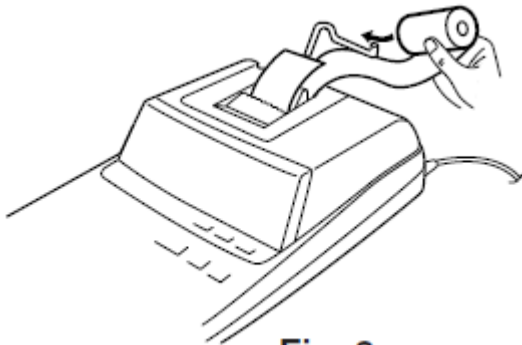

Fig. 3

**DO NOT PULL PAPER BACKWARDS AS THIS MAY CAUSE DAMAGE TO PRINTING MECHANISM.**

## ERRORS

There are several situations which will cause an overflow or an error condition. When this occurs, “E” will be displayed. The contents of the memory at the time of the error are retained.

If an “0\_E” is displayed at the time of the error,  $\boxed{*}$  must be used to clear the calculator. If an “E” with any numerals except zero is displayed, the error may be cleared with  $\boxed{CE}$  or  $\boxed{\rightarrow}$  and the calculation can still be continued.

Also, in rare cases, printing may stop midway and the indication “E” appear on the display. This is not a malfunction but is caused when the calculator is exposed to strong electromagnetic noise or static electricity from an external source. Should this occur, press the  $\boxed{*}$  key and then repeat the calculation from the beginning.

### Error conditions:

1. Entry of more than 12 digits or 11 decimals. This error can be cleared with  $\boxed{CE}$  or  $\boxed{\rightarrow}$ .
2. When the integer portion of an answer exceeds 12 digits.
3. When the integer portion of the contents of the memory or grand total memory exceeds 12 digits.  
(Ex.  $\boxed{*M}$  999999999999  $\boxed{M+}$  1  $\boxed{M+}$  )
4. When any number is divided by zero. (Ex. 5  $\boxed{\div}$  0  $\boxed{=}$  )

## REPLACEMENT OF BATTERY FOR MEMORY PROTECTION

### Time for battery replacement

Life of the memory protection battery is approximately 2,500 hours at 25°C (77°F) with the power plug not connected to the socket.

\* When the memory protection battery is weak, the date/time setting is initialized (1/1/2005, 12:00:00 a.m.).

Verify the date/time setting in the date/clock display mode when connecting the power plug to the socket.

If the date/time setting is modified or incorrect, promptly replace the memory protection battery with new one.  
(The life of the pre-installed battery may be shorter than expected because of the time the calculator spends during shipment.)

### Method of battery replacement

Use one lithium battery (CR2032).

**Caution:** Replacing the battery will clear the date and time settings, as well as the conversion rate, and the tax/ discount rate.

1. Turn the power switch "OFF" and unplug the power supply plug from the outlet.
2. Remove the battery cover on the back of the unit. (Fig. 1)
3. Remove the exhausted battery and install one new lithium battery. Wipe the battery well with a dry cloth and place the plus "+" side upward. (Fig. 2)
4. Replace the battery cover by reversing the removal procedure.
5. Press the RESET switch on the back of the unit (See "RESETTING THE UNIT").

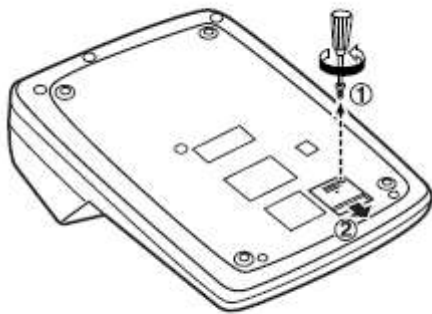

Fig. 1

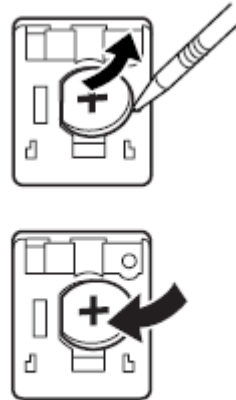

Fig. 2

### After battery replacement

- Connect the power supply plug to an outlet and turn the power switch “ON”.  
Check that “0.” is displayed. If “0.” is not displayed, remove the battery, reinstall it, and check the display again.
- Reconfigure date, time, conversion rate, and tax/discount rate.
- On the battery replacement date label found on the back of the unit, write down the month and year when the battery is replaced, as a reference for the next battery replacement.

### Precautions on battery use

- Do not leave an exhausted battery in the equipment.
- Do not expose the battery to water or flame, and do not take it apart.
- Store batteries out of the reach of small children.

### Notes for handling Lithium batteries:

#### **CAUTION**

Danger of explosion if battery is incorrectly replaced.

Replace only with the same or equivalent type recommended by the manufacturer.

Dispose of used batteries according to the manufacturer’s instructions.

## SPECIFICATIONS

Operating capacity: 12 digits

Power supply:

Operating: AC: 120V, 60Hz

Memory backup: 3V ... (DC) (Lithium battery CR2032 · 1)

Memory Protection Battery lifespan:

About 2,500 hours (While at 25°C (77°F), and the power plug is not connected to the socket.)

### CLOCK SECTION

Accuracy: Within  $\pm 60$  seconds per month average (at 25°C (77°F))

Items to be displayed: month, day, year, hour, minute, second, a.m. "A", p.m. "P"

Items to be printed: month, day, year, hour, minute, a.m. "A", p.m. "P"

Time system: 12-hour

### PRINTING SECTION

Printer: Mechanical printer

Printing speed: Approx. 4.3 lines/sec. (at room temperature of 25°C (77°F))

Printing paper: 57 mm (2-1/4") - 58 mm (2-9/32") wide 80 mm (3-5/32") in diameter (max.)

Operating temperature: 0°C – 40°C (32°F – 104°F)

Power consumption: 66 mA

Dimensions: 222 mm (W) · 327 mm (D) · 78 mm (H) (8-3/4" (W) · 12-7/8" (D) · 3-1/16" (H))

Weight: Approx. 1.9 kg (4.19 lb.) (With battery)

Accessories:

1 lithium battery (installed), 1 battery replacement date label (attached on the unit's back body), 1 paper roll, 1 ink ribbon (installed), and operation manual

## **WARNING**

THE VOLTAGE USED MUST BE THE SAME AS SPECIFIED ON THIS CALCULATOR. USING THIS CALCULATOR WITH A HIGHER VOLTAGE THAN THAT WHICH IS SPECIFIED IS DANGEROUS AND MAY RESULT IN A FIRE OR OTHER TYPE OF ACCIDENT CAUSING DAMAGE. WE ARE NOT RESPONSIBLE FOR ANY DAMAGE RESULTING FROM USE OF THIS CALCULATOR WITH A VOLTAGE OTHER THAN THAT WHICH IS SPECIFIED.

## RESETTING THE UNIT

Strong impacts, exposure to electrical fields, or other unusual conditions may render the unit inoperative, and pressing the keys will have no effect. If this occurs, you will have to press the RESET switch on the bottom of the unit. The RESET switch should be pressed only when:

- An abnormal event occurs and all keys are disabled.

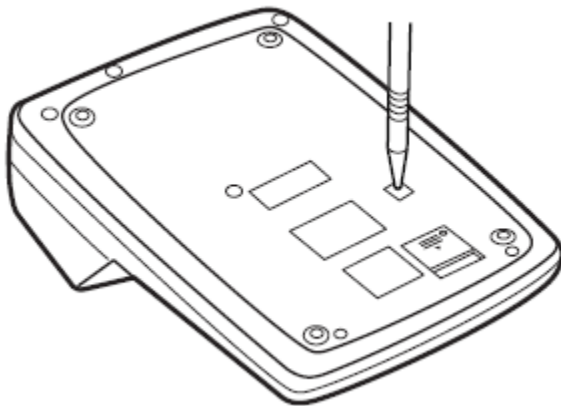

### Notes:

- Pressing the RESET switch will clear the set date and time configuration, as well as conversion rate, tax/discount rate, and memory contents.
- Use only a ballpoint pen to press the RESET switch. Do not use anything breakable or anything with a sharp tip, such as a needle.
- After pressing the RESET switch, connect the power supply plug to an outlet. Turn the power switch “ON” and check that “0.” is displayed.



# CALCULATION EXAMPLES

General instructions:





1. Set the decimal selector as specified in each example. The rounding selector should be in the “5/4” position unless otherwise specified.
2. The constant/add mode selector and grand total/rate setting mode selector should be in the “•” position (off) unless otherwise specified.
3. The print/item count mode selector should be in the “P” position unless otherwise specified.
4. If an error is made while entering a number, press  or  and enter the correct number.
5. Negative values are printed with “-” symbol in red.

Printing Date and Time

## PRINTING DATE AND TIME IMPRESIÓN DE LA FECHA Y LA HORA

EXAMPLE: When on October 20, 2005, 1:52:00 p.m.

EJEMPLO: En el 20 de octubre de 2005, a las 1:52:00 p.m.

Operation Operación	Display Visualización	Print Impresión
 *1 	10-20-2005  0.	#10•20•2005•••••
  	1-52 00 P  0.	#1•52                      P

\*1 : If the date is not shown on the display, press  to show the date.

\*1 : Si la fecha no se muestra en el visualizador, pulse  para hacer que se indique.



# Time Calculations

## TIME CALCULATIONS CÁLCULOS DE TIEMPO

EXAMPLE 1: 4 hours 15 minutes 20 seconds + 3 hours 50 minutes 18 seconds =

EJEMPLO 1: 4 horas 15 minutos 20 segundos + 3 horas 50 minutos 18 segundos =

**F 6 3 2 1 0**



	<input type="button" value="*"/>		
4	<input type="button" value="TIME CALC"/>	4_00_--	
15	<input type="button" value="TIME CALC"/>	4_15_00	
20	<input type="button" value="±"/>	4_15_20	4 • 15 • 20 +
3	<input type="button" value="TIME CALC"/>	3_00_--	
50	<input type="button" value="TIME CALC"/>	3_50_00	
18	<input type="button" value="±"/>	8_05_38	3 • 50 • 18 +
	<input type="button" value="*"/>	8_05_38	8 • 05 • 38 *

EXAMPLE 2: Calculate the payroll amount at an hourly rate of \$15 for the total number of hours worked for 7 hours 45 minutes per day for five days.

EJEMPLO 2: Calcule el salario a un precio por hora de 15 dólares para el número total de horas trabajadas de 7 horas y 45 minutos al día durante cinco días.

**F 6 3 2 1 0**



	<input type="button" value="*"/>		
7	<input type="button" value="TIME CALC"/>	7_00_--	
45	<input type="button" value="x"/>	7_45_00	7 • 45 • 00 ×
5	<input type="button" value="±"/>		5 • =
			38 • 75 *
		38.75	
	<input type="button" value="x"/>	38.75	38 • 75 ×
15	<input type="button" value="±"/>		15 • =
			581 • 25 *
		581.25	

## Mixed Calculations

### MIXED CALCULATION/CÁLCULOS MIXTOS

$$(240 + 180 + 180 - 75) \times 8 =$$

F 6 3 2 1 0



240	$\boxed{+}$	240.	240•+
180	$\boxed{+}$	420.	180•+
	$\boxed{+}$	600.	180•+
75	$\boxed{-=}$	525.	75•-
	$\boxed{\times}$		525•◇
		525.	525•×
8	$\boxed{+}$		8•=
		4,200.	4,200•*

# Constant Calculations

## CONSTANT/CONSTANTES

$$62.35 \times 11.11 =$$

$$62.35 \times 22.22 =$$

**K • A**

**F 6 3 2 1 0**



62.35 <input type="button" value="×"/>	62.35	62•35 ×
11.11 <input type="button" value="±"/>		11•11 = K
		692•71 *
22.22 <input type="button" value="±"/>	692.71	
		22•22 = K
		1,385•42 *
	1,385.42	

$$11.11 \div 77.77 =$$

$$22.22 \div 77.77 =$$

**K • A**

**F 6 3 2 1 0**









11.11 <input type="button" value="÷"/>	11.11	11•11 ÷
77.77 <input type="button" value="±"/>		77•77 = K
		0•143 *
22.22 <input type="button" value="±"/>	0.143	
		22•22 = K
		0•286 *
	0.286	

## Addition and Subtraction with Add Mode

### ADDITION AND SUBTRACTION WITH ADD MODE/ SUMA Y RESTA CON MODO DE SUMA

$$12.45 + 16.24 + 19.35 - 5.21 =$$

K • A    F 6 3 2 1 0  
    

Operation Operación	Display Visualización	Print Impresión
1245 	12.45	12•45 +
1624 	28.69	16•24 +
1935 	48.04	19•35 +
521 	42.83	5•21 -
	42.83	42•83 *

\* :  was not used in the entries.

\* :  no ha sido usada en las entradas.

## Correction of Errors

### CORRECTION OF ERRORS/CORRECCIÓN DE ERRORES

123 + 556 → 123 + 456      **K • A**      **F 6 3 2 1 0**

123	<span style="border: 1px solid black; padding: 2px;">+</span>	123.	123• +
556	<span style="border: 1px solid black; padding: 2px;">CE</span>	0.	
456	<span style="border: 1px solid black; padding: 2px;">+</span>	579.	456• +
	<span style="border: 1px solid black; padding: 2px;">*</span>		579• *
		579.	

1234567 → 1234578      **F 6 3 2 1 0**

1234567		1,234,567.	
	<span style="border: 1px solid black; padding: 2px;">→</span>	123,456.	
	<span style="border: 1px solid black; padding: 2px;">→</span>	12,345.	
78		1,234,578.	

## Percent

### PERCENT/PORCENTAJES

**F 6 3 2 1 0**

$100 \times 25\% =$

$100 \times$ $25 \%$	$100.$  $25.00$	$100 \cdot \times$ $25 \cdot \%$ $25 \cdot 00 *$
-------------------------	-----------------------	--

**F 6 3 2 1 0**

$(123 \div 1368) \times 100 =$

$123 \div$ $1368 \%$	$123.$  $8.99$	$123 \cdot \div$ $1,368 \cdot \%$ $8 \cdot 99 *$
-------------------------	----------------------	--

## Percent Change

### PERCENT CHANGE/CAMBIO PORCENTUAL

- Calculate the dollar difference (a) and the percent change (b) between two yearly sales figures \$1,500 in one year and \$1,300 in the previous year.
- Calcular la diferencia en dólares (a) y el cambio porcentual (b) entre dos cifras de ventas anuales, \$1.500 en un año y \$1.300 el año anterior.

**F 6 3 2 1 0**

$1500 +$ $1300 - =$ MU	$1,500.00$ $200.00$  $15.38$	$1,500 \cdot 00 +$ $1,300 \cdot 00 -$ $200 \cdot 00 * (a)$ $15 \cdot 38 \% C (b)$
------------------------------	---------------------------------------	--

## Markup and Margin

### MARKUP AND MARGIN

Markup and Profit Margin are both ways of calculating percent profit.

- Profit margin is percent profit vs. selling price.
- Markup is percent profit vs. cost.
- Cost is the cost.
- Sell is the selling price.
- GP is the gross profit.
- Mkup is the percent profit based on cost.
- Mrgn is the percent profit based on selling price.

To find Para encontrar	Knowing Sabiendo	Operation Operación
Mrgn	Sell, Cost	Cost $\frac{-}{=}$ Sell $\frac{+}{=}$ MU
Mkup	Sell, Cost	Sell $\frac{+}{=}$ Cost $\frac{-}{=}$ MU
Sell	Cost, Mrgn	Cost $\div$ Mrgn MU
Cost	Sell, Mrgn	Sell $\times$ Mrgn $\frac{+}{\cancel{=}}$ MU
Sell	Cost, Mkup	Cost $\times$ Mkup MU
Cost	Sell, Mkup	Sell $\div$ Mkup $\frac{+}{\cancel{=}}$ MU

Ex./Ej.

Cost	\$200
Sell	\$250
GP	\$50
Mkup	25%
Mrgn	20%

Operation Operación	Display Visualización	Print Impresión
200 $\div$	200.	200 • $\div$ Cost
20 MU		20 • %M Mrgn
		250 • 00 * Sell
		50 • 00 GP GP
	50.00	

F 6 3 2 1 0



# Grand Total

## GRAND TOTAL/TOTAL GLOBAL

$100 + 200 + 300 =$   
 $+ ) 500 - 600 + 700 =$   

---

 Grand total/Total global

OFF • P P·IC  
  
 RATE  
 GT • SET F 6 3 2 1 0

<input type="text" value="GT"/> <input type="text" value="*"/>		
100 <input type="text" value="±"/>	100.	100• +
200 <input type="text" value="±"/>	300.	200• +
300 <input type="text" value="±"/>	600.	300• +
<input type="text" value="*"/>		003
	600.●	600• *+
500 <input type="text" value="±"/>	500.●	500• +
600 <input type="text" value="--"/>	100.●	600• -
700 <input type="text" value="±"/>	600.●	700• +
<input type="text" value="*"/>		001
	600.●	600• *+
<input type="text" value="GT"/>		002
		1,200• *G
	1,200.	



# Memory

## MEMORY/MEMORIA

$$46 \times 78 = \textcircled{1}$$

$$+) 125 \div 5 = \textcircled{2}$$

$$-) 72 \times 8 = \textcircled{3}$$

---

Total  $\textcircled{4}$

RATE

GT • SET      F 6 3 2 1 0

||

|||

	<b>*M</b> *		
46	<b>×</b>	46.	46•×
78	<b>M+</b>		78•=
		3,588. <sup>M</sup>	3•588•+M $\textcircled{1}$
125	<b>÷</b>	125. <sup>M</sup>	125•÷
5	<b>M+</b>		5•=
		25. <sup>M</sup>	25•+M $\textcircled{2}$
72	<b>×</b>	72. <sup>M</sup>	72•×
8	<b>M-</b>		8•=
		576. <sup>M</sup>	576•-M $\textcircled{3}$
	<b>◊M</b>		001
		3,037. <sup>M</sup>	3•037•◊M $\textcircled{4}$
	<b>*M</b>		001
		3,037.	3•037•*M

\*: Press **\*M** to clear the memory before starting a memory calculation.

\*: Apretar **\*M** para cancelar la memoria antes de empezar a efectuar un cálculo con memoria.

## Item Count Calculation

### ITEM COUNT CALCULATION/ CÁLCULO DE CUENTA DE ARTÍCULOS

Bill No. N° de factura	Number of bills Cantidad de facturas	Amount Importe
1	1	\$100.55
2	1	\$200.00
3	1	\$200.00
4	1	\$400.55
5	1	\$500.65
Total	(a)	(b)

OFF • P P-IC F 6 3 2 1 0  



	*		
100.55	±	100.55	100•55 +
200	±	300.55	200•00 +
	±	500.55	200•00 +
400.55	±	901.10	400•55 +
500.65	±	1,401.75	500•65 +
	*		005 (a)
			1•401•75 * (b)
		1,401.75	

## Add-on and Discount

### ADD-ON AND DISCOUNT/ RECARGOS Y DESCUENTOS

A 5% add-on to 100./

Un 5% de recargo sobre 100.

**F 6 3 2 1 0**



100 <input type="text" value="x"/>	100.	100. ×
5 <input type="text" value="MU"/>		5. %
		5.00 Increase Incremento
	105.00	105.00 * New amount Nueva cantidad

A 10% discount on 100./

Un 10% de descuento sobre 100.

**F 6 3 2 1 0**



100 <input type="text" value="x"/>	100.	100. ×
10 <input type="text" value="÷"/> <input type="text" value="MU"/>		- 10. %
		- 10.00
	90.00	90.00 *

# Averaging

## AVERAGING / PROMEDIO

Ex. / Ej.

	<u>Day / Día</u>	<u>Sales / Ventas</u>
If /	Monday / Lunes .....	\$123.15 / \$123,15
Si el	Tuesday / Martes .....	\$118.00 / \$118,00
	Wednesday / Miércoles .....	\$131.58 / \$131,58
	Thursday / Jueves .....	\$125.02 / \$125,02
	Friday / Viernes .....	\$158.25 / \$158,25
	Total Sales .....	\$656.00 for 5 days

El total de ventas de los 5 días = \$656,00

Then Average Sales = \$131.20 /

Por lo tant: Promedio de las ventas = \$131,20

		RATE	
OFF • P	P • IC	GT • SET	K • A
<input type="text"/>	<input type="text"/>	<input type="text"/>	<input type="text"/>
12315	*	123.15	123•15 +
118	•	241.15	118•00 +
13158		372.73	131•58 +
12502		497.75	125•02 +
15825		656.00	158•25 +
	AVG		005
			656•00 *
			131•20 AG
		131.20	

# Tax Rate Calculations

## TAX RATE CALCULATIONS / CÁLCULOS CON EL TIPO DE IMPUESTO

**EXAMPLE 1:** Set a 5% tax rate.  
Calculate the tax on \$800 and calculate the total including tax.

**EJEMPLO 1:** Establezca un tasa de impuesto del 5%.  
Calcule el impuesto sobre \$800 y calcule el total incluyendo el impuesto.

**F 6 3 2 1 0**

<b>RATE</b> <b>GT • SET</b> <input type="text" value="00"/> * <input type="text" value="00"/>		
<b>RATE</b> <b>GT • SET</b> <input type="text" value="05"/>	5.	
5 <input type="text" value="TAX+"/>		TX
<b>RATE</b> <b>GT • SET</b> <input type="text" value="00"/>	5.000	5•000 %
<b>RATE</b> <b>GT • SET</b> <input type="text" value="00"/>		
800 <input type="text" value="TAX+"/>		800•
		40• TX
	840.	840•

**EXAMPLE 2:** Perform two calculations using \$840 and \$525, both of which already include tax. Calculate the tax on the total and the total without tax. (tax rate: 5%)

**EJEMPLO 2:** Realice dos cálculos utilizando \$840 y \$525, los cuales ya incluyen impuesto. Calcule el impuesto sobre el total y el total sin impuesto. (tasa de impuestos: 5%)

**F 6 3 2 1 0**

840 <input type="text" value="±"/>	840.	840• +
525 <input type="text" value="±"/>	1,365.	525• +
<input type="text" value="TAX-"/>		1,365• *
		TX
		65• -
	1,300.	1,300•

# Conversion Calculation Examples

## CONVERSION CALCULATION EXAMPLES / EJEMPLOS DE CÁLCULO DE CAMBIO

EXAMPLE 1: Set the conversion rate (\$1 = ¥123.45).

EJEMPLO 1: Ajuste la tasa de conversión (\$1 = ¥123,45).

		RATE GT • SET <input style="width: 50px;" type="text"/>
* * 123.45 xRATE	123.450	TC 123•450 =

EXAMPLE 2: Convert \$120 to yen (\$1 = ¥123.45).

EJEMPLO 2: Convierta \$120 yenes en dólares (\$1 = ¥123,45).

		RATE GT • SET <input style="width: 50px;" type="text"/>
		F 6 3 2 1 0 <input style="width: 50px;" type="text"/>
120 xRATE	14,814.	120• 14•814• TC

EXAMPLE 3: Set the conversion rate (1 meter = 39.3701 inches).

EJEMPLO 3: Ajuste la tasa de conversión (1 metro = 39,3701 pulgadas).

		RATE GT • SET <input style="width: 50px;" type="text"/>
* * 39.3701 xRATE	39.3701	TC 39•3701 =

EXAMPLE 4: Convert 472.4412 inches to meters (1 meter = 39.3701 inches).

EJEMPLO 4: Convierta 472,4412 pulgadas en metros (1 metro = 39,3701 pulgadas).

		RATE GT • SET <input style="width: 50px;" type="text"/>
		F 6 3 2 1 0 <input style="width: 50px;" type="text"/>
472.4412 xRATE	12.	472•4412 12• TE

- Each time  is pressed after a result is displayed, the result toggles between the sexagesimal and decimal formats.
- This printer calculator supports the following repertoire of time calculations:  
Addition, subtraction, multiplication and division, constant calculation, memory calculation, grand total memory calculation, average calculation, and percent calculation.
- Calculation range:  
–999999 hours 59 minutes 59 seconds – 999999 hours 59 minutes 59 seconds
- Because time calculation results are rounded down to 13 decimal places after sexagesimal-to-decimal conversion, calculation errors may be introduced.  
Time calculations are displayed in sexagesimal with the fraction part of a second being rounded off.
- The sexagesimal arithmetic specifications of this printer calculator are as follows:  
Addition (Subtraction is similar to addition.)  
(Sexagesimal) + (Sexagesimal) = (Sexagesimal)  
(Sexagesimal) + (Decimal) = (Sexagesimal)  
(Decimal) + (Sexagesimal) = (Sexagesimal)  
  
Multiplication (Division is similar to multiplication.)  
(Sexagesimal) · (Sexagesimal) = (Decimal)  
(Sexagesimal) · (Decimal) = (Decimal)  
(Decimal) · (Sexagesimal) = (Decimal)

**Caution!**

The socket outlet shall be installed near the equipment and shall be easily accessible.

For your convenience, Genuine Sharp Supplies, Accessories, and additional Sharp Products can be

purchased from the Authorized Sharp Reseller where  
you purchased your product or on-line at:  
**[www.sharpcalculators.com](http://www.sharpcalculators.com)**



## LIMITED WARRANTY

SHARP ELECTRONICS CORPORATION warrants to the first consumer purchaser that this Sharp brand product (the "Product"), when shipped in its original container, will be free from defective workmanship and materials, and agrees that it will, at its option, either repair the defect or replace the defective Product or part thereof with a new or remanufactured equivalent at no charge to the purchaser for parts or labor for the period(s) set forth below. This warranty does not apply to any appearance items of the Product nor to the additional excluded item(s) set forth below nor to any Product the exterior of which has been damaged or defaced, which has been subjected to improper voltage or other misuse, abnormal service or handling, or which has been altered or modified in design or construction.

In order to enforce the rights under this limited warranty, the purchaser should follow the steps set forth below and provide proof of purchase to the servicer.

The limited warranty described herein is in addition to whatever implied warranties may be granted to purchasers by law. ALL IMPLIED WARRANTIES INCLUDING THE WARRANTIES OF

MERCHANTABILITY AND FITNESS FOR USE ARE LIMITED TO THE PERIOD(S) FROM THE DATE OF PURCHASE SET FORTH BELOW. Some states do not allow limitations on how long an implied warranty lasts, so the above limitation may not apply to you.

Neither the sales personnel of the seller nor any other person is authorized to make any warranties other than those described herein, or to extend the duration of any warranties beyond the time period described herein on behalf of Sharp.

The warranties described herein shall be the sole and exclusive warranties granted by Sharp and shall be the sole and exclusive remedy available to the purchaser. Correction of defects, in the manner and for the period of time described herein, shall constitute complete fulfillment of all liabilities and responsibilities of Sharp to the purchaser with respect to the Product, and shall constitute full satisfaction of all claims, whether based on contract, negligence, strict liability or otherwise. In no event shall Sharp be liable, or in any way responsible, for any damages or defects in the Product which were caused by repairs or attempted repairs performed by anyone other than an authorized servicer. Nor shall Sharp be liable or in any way responsible for any incidental or consequential economic or property damage. Some states do not allow the exclusion of incidental or consequential damages, so the above exclusion may not apply to you.

THIS WARRANTY GIVES YOU SPECIFIC LEGAL RIGHTS. YOU MAY ALSO HAVE OTHER RIGHTS WHICH VARY FROM STATE TO STATE.

---

Your Product : Electronic Calculator

Warranty Period for this Product: Six (6) months parts and labor from date of purchase.

Additional Items Excluded: Any consumable items such as paper, maintenance cartridge, ink from Warranty Coverage: cartridges supplied with the Product or to any equipment or any hardware, software, firmware, fluorescent lamp, power cords, covers, rubber parts, or peripherals other than the Product.

Where to Obtain Service: At a Sharp Authorized Servicer located in the United States. To find out the location of the nearest Sharp Authorized Servicer, call Sharp toll free at 1-800-BE-SHARP.

What to do to Obtain Service: Ship (prepaid) or carry in your Product to a Sharp Authorized Servicer. Be sure to have proof of purchase available. If you ship or mail the Product, be sure it is packaged carefully.

**FOR YOUR RECORDS .....**

For your assistance in reporting this electronic calculator in case of loss or theft, please record below the model number and serial number which are located on the bottom of the unit. Please retain this information.

Model Number \_\_\_\_\_ Serial Number \_\_\_\_\_

Date of Purchase \_\_\_\_\_ Place of Purchase \_\_\_\_\_