

THE **250** BEST

SHOP TRICKS



A supplement to

**WOODWORKER'S
JOURNAL**

THE 250 BEST SHOP TRICKS

One of the best things that happens when a bunch of woodworkers get together is sharing shop secrets. You've got a great idea for getting more accurate cuts? I'll trade you for some of my hardware storage solutions!

Here at *Woodworker's Journal*, we're lucky enough to get a never-ending stream of these hints from our readers. We call them *Tricks of the Trade*, and we share them regularly in our magazine. We know how useful they are to our readers — so we decided to create an even better tool by putting over 250 of these tricks in one place!



Larry N. Stoiaken
Editor in Chief

**WOODWORKER'S
WJOURNAL**
Copyright © 2000 Rockler Press.

All rights reserved. No part of this publication may be reproduced, stored in electronic retrieval systems, or transmitted in any form or by any means, including electronic, photocopying, mechanical or otherwise, without the prior written permission of the copyright owner.

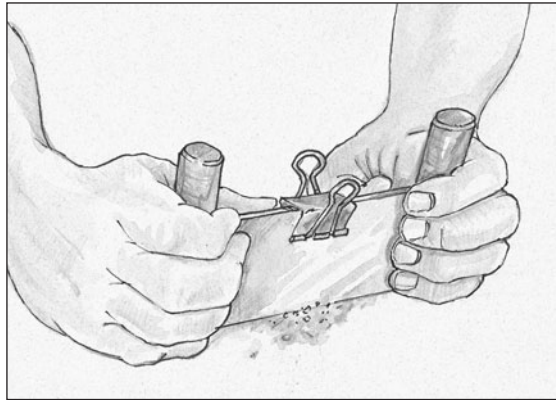

Q&A

"How do I stop sawdust from sticking to the gear and screw mechanism of my table saw?"

The answer, according to Walter France of Lithia Springs, Georgia, is to give the mechanism a thorough cleaning, then spray with silicone. This causes the dust to fall off instead of accumulating, and it also prevents rust.

A Simple Scraper Holder

This simple scraper holder consists of two dowels joined by a flexible piece of 1/8" plywood. A 1/4" slot is routed into each dowel and the dowels are then glued to the plywood. To achieve maximum flexibility, the plywood is cut so the exterior grain runs parallel to the dowels. The blade fits into the slots and is held by a binder clip.

*A. M. Benson
Houston, Texas*

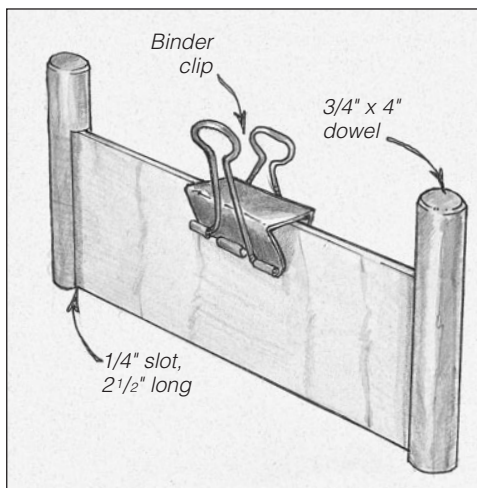

The Half-lid Paint Striker

Next time you begin a paint job requiring a whole can of paint, remove the lid and use a hacksaw to cut it in two. Put one half aside for later, then slightly bend down the cut edge of the other and press it back in place atop the can. This half lid makes a sturdy brush shelf and the cut edge can be used to strike excess paint from the brush.

*Lane Olinghouse
Everett, Washington*

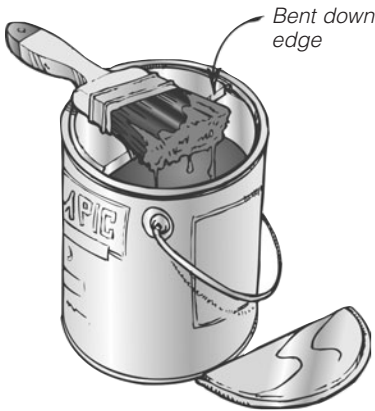

Tape Measure Tip

The bulky case of a tape measure sometimes gets in the way in tight spots, so I kept a one-foot section of an old tape and ground both ends to make it accurate. I also made 24" and 36" measures this way — they work great inside cabinets.

*Robert Guyan
Portland, Oregon*

Quick Tip

Professional woodworkers generally keep their drawings and notes on a clipboard, but even then they get dog-eared and dirty. A piece of clear Plexiglas™, cut to 9" x 11" size, makes a great protector, but it also opens up a few other possibilities. By gluing a transparent ruler and protractor (both are available at office supply stores at very little cost) to the Plexiglas, you'll have an instant way to measure drawings, small parts and angles. Use a clear glue.

Q&A

*“How do I straighten
a warped board?”*

*If a board is warped along
its edge, that's an easy fix.
Simply run it across
a jointer. If it's cupped
across its width, you can try
ripping it into two or even
three narrow boards,
jointing their edges, then
reversing the grain in every
other board when you glue
them back together.
Twisted stock is usually
beyond help: your best bet
may be to cut it up and use
it where small parts are
required.*

There's a Hole in the Bucket ...

I put a plastic bag in my Shop-Vac to hold the dust so it would be easier to dump out. But the bag kept getting sucked up into the filter. So I found a pail that just fits inside the plastic bag, and I cut the bottom out. Now, I just take the pail out first and the bag comes out easily — and dust doesn't fly all over!

*Arthur Duffie
Kalamazoo, Michigan*

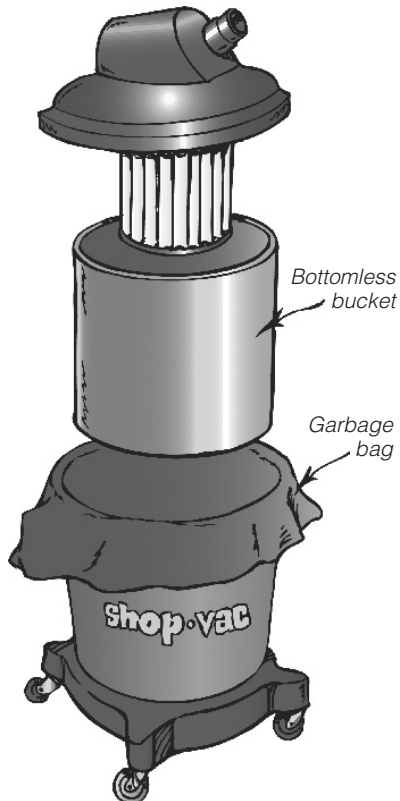

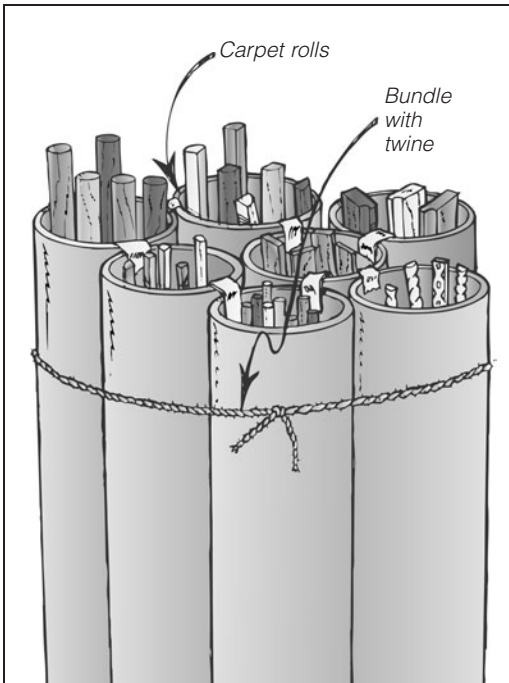

Small Stock Storage

Heavy cardboard carpet tubes (usually available FREE from a local carpet layer or store) can be cut to any length and bundled together with cord. Mine are 18" long, and I use them to separate different dowel scraps and leftover hardwood moldings. I can check my inventory at a glance: the tubes rest on the floor under my workbench, set on 2x4 scraps to keep them off the concrete. While tying the cord, use masking tape to temporarily hold them together (or you'll look like Charlie Chaplin chasing them all over!).

*Barb Siddiqui
Wenatchee, Washington*

Quick Tip

A surface planer doesn't flatten boards. All it does is make them the same thickness along their length. If you feed a warped board through a planer, all you'll get at the other end is a uniformly thick warped board.

To get a flat board, first dress one face of the board on a jointer or a wide belt sander. Then lay the flattened (dressed) face on the planer bed, while the knives flatten the second face.

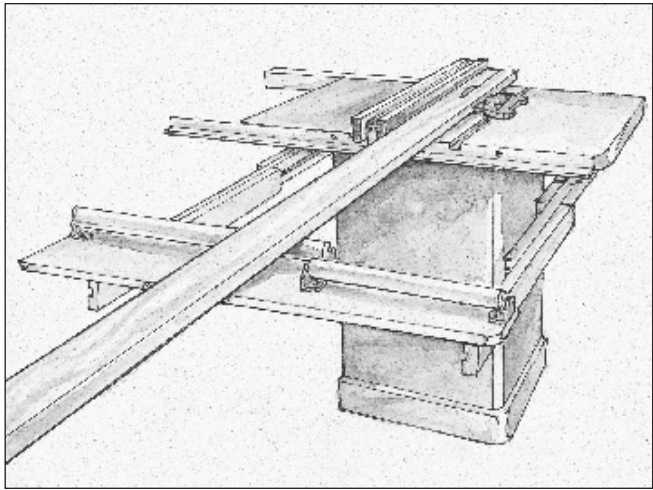

Q&A

“What do I do with a worn-out cordless drill battery?”

Ni-Cad (nickel-cadmium) batteries pose a serious threat to our groundwater, so they're not welcome at the landfill. Most cities have a system in place for dealing with them: call your courthouse or landfill office. Or call 800-8-BATTERY and get the name of a local retailer who will take them off your hands ... without a charge!

Sliding Supports

I use a pair of dining table slides and a couple of rollers to support long boards on my table saw (above). I attached the slides to the bottom of the saw's tabletop and mounted the rollers on a board stretched between them. When not in use, the slides can be pushed out of the way (below).

*Robert Floyd
Hilton, New York*

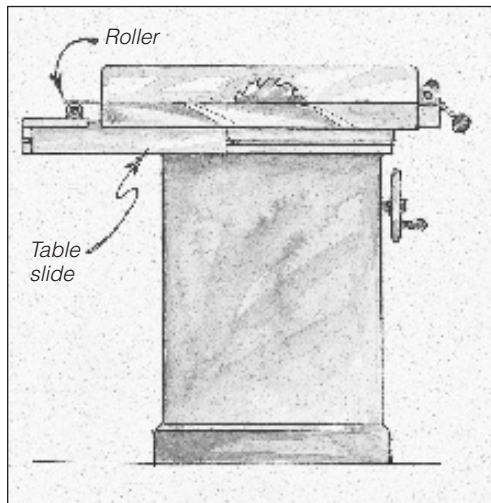

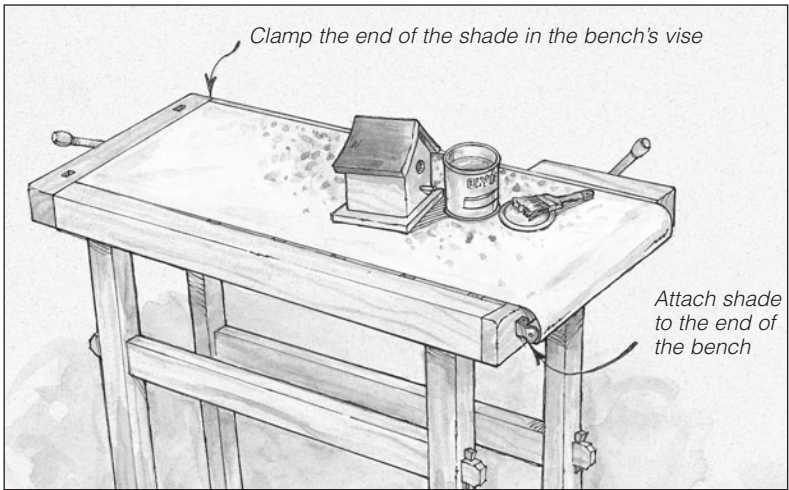

Bench Protectors

To protect my maple workbench from paint or stain splatters, I mounted a white vinyl window shade roller to one end of the worktop. When I'm ready to finish, I just extend the shade across the bench. After the finish dries, the shade rolls out of the way. And the best part is that replacement shades are very inexpensive.

*Robert O. Wendel
Marlboro, New Jersey*

Wood Filler Woes

I wanted to avoid the inevitable blemishes that occur when excess wood filler surrounds nail heads in trim and moldings. So I came up with this idea: place a short piece of masking tape over the area around the nail head, then set the nail right through the tape. Apply the wood filler and, while it is still soft, peel off the tape. A perfect round spot is left, with no accumulation on the surrounding area.

*James Vasi
Williamsville, New York*

Quick Tip

Turners often leave a short log inside the bag on their dust collection system. The combination of flowing air, sawdust and chips tends to dry out the stock in an even, controlled fashion. But try it on a less favored piece first: results vary widely depending on how often the dust collector is used, the log species, the geographic location of the shop and the length of time the log is allowed to stay in the bag.

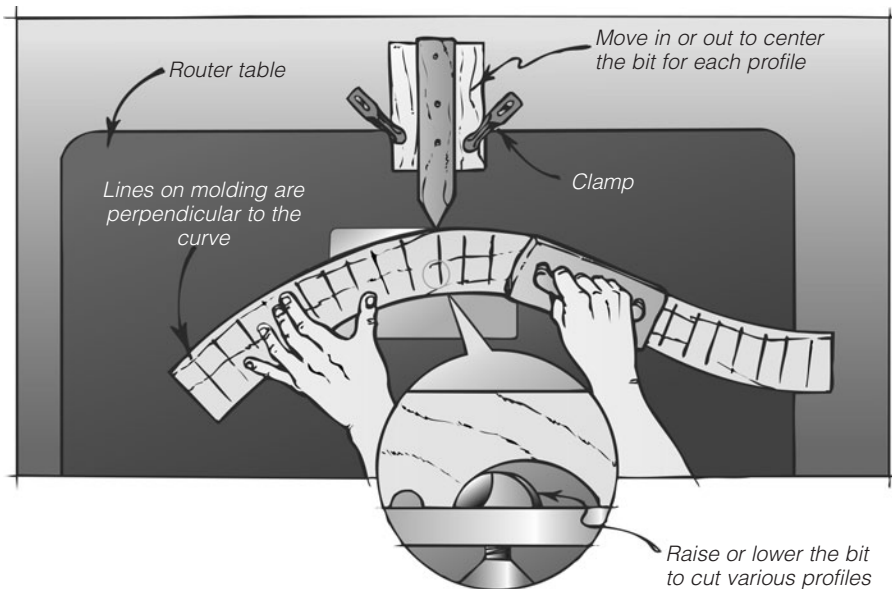

Q&A

"I use wood blocks to save the workpiece while I tighten clamps, but I run out of fingers trying to hold them in place. Any ideas?"

Kenneth J. Shaw of Holley, New York tells us that he attaches those scraps to the jaws of his clamps with hot melt glue, so they're removable when he's done.

S-shaped Moldings on a Router Table

None of my woodworking friends could advise me how to cut a profile down the middle of an S-shaped molding, so I came up with the solution shown here. After band-sawing and drum sanding the piece to shape, I made pencil marks every inch along the back of the workpiece. These were perpendicular to the curve (see drawing). Then I clamped a pointed guide fence to the router table that centered the bit where I wanted it, set my bit height, and started running the piece through the cutter. By adjusting the work so that the pencil lines were always at 90° to the fence, I kept the cut in line. A little carving and sanding smoothed out any rough spots.

*G. R. Williams
Fostoria, Ohio*

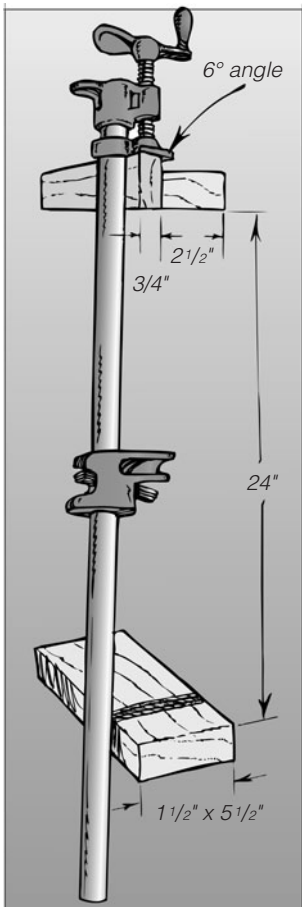

Three-piece Clamp Hanger

Storing pipe clamps has always been a challenge for me. I think I've contemplated every system in the world. Quite by accident, I stumbled on the method shown here. It requires only three pieces of wood assembled with drywall screws.

*Michael Burton
Ogden, Utah*

Quick Tip

Hammering small nails can be a real challenge, especially if you have large fingers. One way to deal with the problem is to stick the nail through a piece of paper, then use the paper to hold it in place while you start driving it. Once the nail is secure, the paper just pulls away. Craig Kimpston of Grimes, Iowa, has a more innovative method: he uses the teeth on his pocket comb to hold nails while he starts them.

Q&A

“How do I know when a saw blade or router bit is dull?”

The most obvious sign is that the bit or blade is cutting more slowly than it was when first installed. But if you don't use the tool frequently, you might not notice that. So, look for rough edges, an uneven kerf and signs of burning. Dull bits and blades have to work harder, so they heat up more ... and that leads to pitch buildup.

An Extra Vice for your Shop

While working on a project requiring hand-cut dovetails, I came up with this simple vise idea. I took a scrap of hardwood 1" thick by 18" long by 8" wide and predrilled and countersunk holes 1" from the top edge. Then I cut a slot on both ends, 3" deep and wide enough to accommodate my Bessey bar clamps. I took a second piece the same size and cut the slots in the same place. Then I fastened the first piece to the workbench, slid in the clamps, and put the second piece on with the screw ends facing out. Now I have an extra wood vise whenever I need one.

*Pat Pelkey
Oswego, New York*

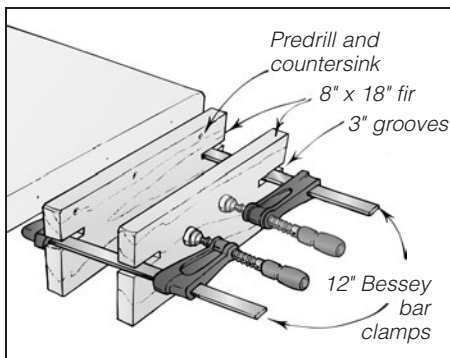

Creating a Curve

To draw a curve, compress a thin strip of wood between the jaws of a bar clamp. The clamp threads allow micro-adjustments of the curve.

*William Adsit
Milford, Illinois*

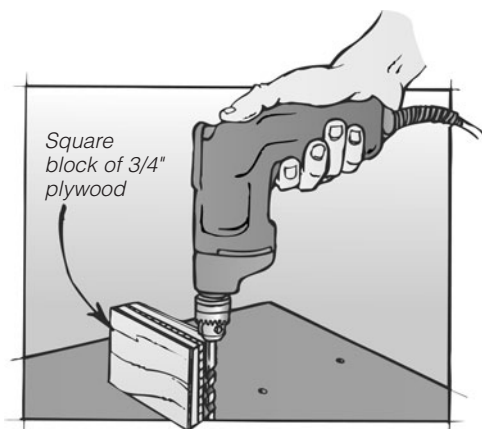

Keeping the Bit Perpendicular

I've seen many great tips on how to hold a hand drill at a right angle to your work surface — everything from mirrors to specially cut jigs. I just use a piece of 3/4" plywood cut at a right angle. The 90° angle keeps the drill bit straight one way, and I use the very visible glue lines in the plywood to keep the bit perpendicular the other way. It's always worked for me, and it's pretty convenient.

*Henry R. Dillon
Riverdale, Georgia*

Router Skid Marks

When trimming plastic laminate, avoid black marks left by the router sub-base by occasionally spraying with WD40. This will also lubricate the bearing. (You shouldn't use oil on wood surfaces, though.)

*Joe Nelson
S. CleElum, Washington*

Quick Tip

If you're getting a little tearout or feathering on boards as you run them across the jointer, try reversing the direction of the feed. Sometimes, grain hits the knives at the wrong angle. By switching the front of the board to the back, you offer a different grain angle to the cutters. If the knives are nicked, just loosen one and move it left or right, as far as it will go. Leave the others as they are and you'll get clean, sharp cuts.

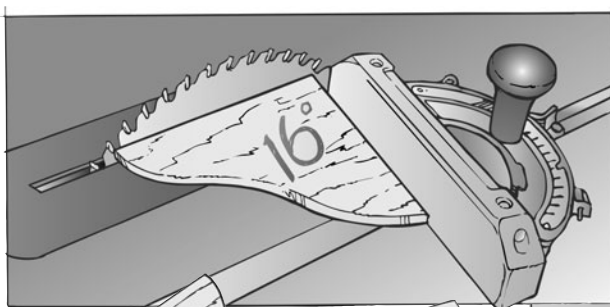

Templates work great for setting both miter gauge and blade angles

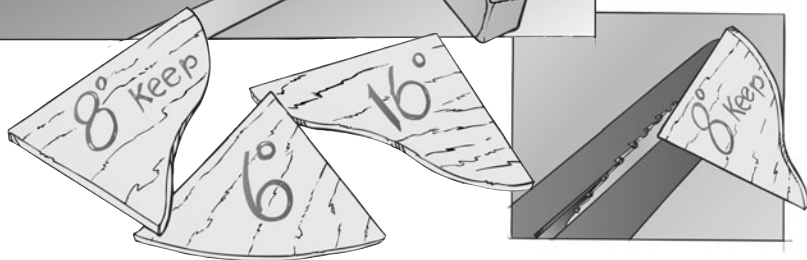

Q&A

“How do I remove water stains from a table?”

One of the most unusual and effective methods we’ve heard about (but never tried!) is to rub out the mark with standard mayonnaise! Apparently, mayo has just the right grit and chemical makeup to neutralize the blemish.

Table Saw Angles

Rather than look for a protractor or T-bevel, or trust the arrow indicators, I made a set of the angles I most commonly use to adjust my table saw and miter gauge. 1/4" plywood works fine for this. I use them again and again to set my saw for cutting angles, pentagons, hexagons, octagons and even segmented bowls.

*Richard Dorn
Oelwein, Iowa*

Toner Trick

When I need to transfer a pattern or drawing onto a piece of wood, I make a copy on a copy machine and iron it onto the wood. The heat from the iron transfers the toner onto the wood.

*E. Frohnhofer
Riverhead, New York*

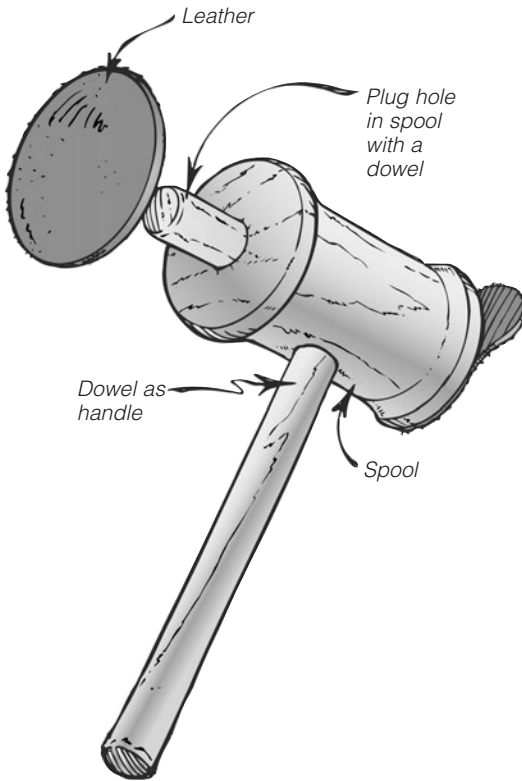

Thread Spool: A Shop Aid

Sometimes, when doing light woodworking or model construction, a small wooden mallet is very handy. I found an empty thread spool made just such a mallet. First, I glued a section of dowel through the center hole of the spool and sanded this flush with the spool faces. Then I glued a leather disk to each of the faces. Next, I drilled a hole through the body of the spool and glued a short piece of dowel there to act as a handle. I have found this tool to be most useful for model work.

*Howard E. Moody
Upper Jay, New York*

Quick Tip

If you frequently cut large sheets of plywood for casework, you know how hard it is to reach the table saw's switch when something goes wrong. Many catalog and retail outlets sell a foot-operated switch that is plugged into the wall, then the saw is plugged into the switch. By placing the switch a couple of feet in front of the saw, but a little to one side, you can easily reach it in an emergency, yet avoid accidentally turning off the saw in the middle of a cut.

Q&A

“What’s the sequence for sanding grits?”

Most woodworking projects are sanded first with a 100 or 120 grit paper, then a 150. This is usually followed by 180 grit paper, then 220. After applying a first coat of finish (or a sanding seal coat), you can break it down with 280, 320 or 400 grit paper. The finest grade of over-the-counter paper is 800 grit, although finer polishing papers are available. At the other end of the scale, stock removal is done with coarse grits from 12 to 60.

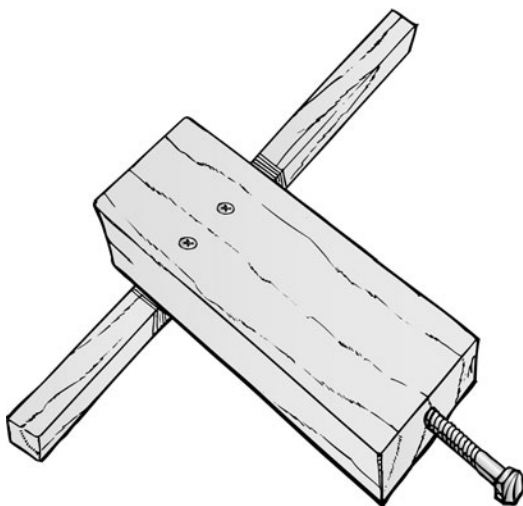
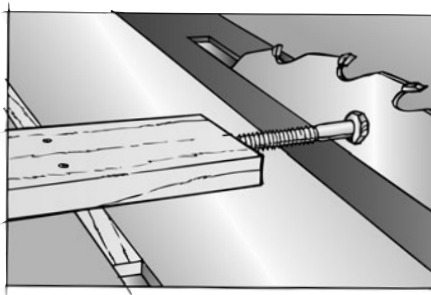

Table Saw Alignment Jig

This little jig (above and below) slides in the miter gauge slot on my table saw and allows me to align the blade perfectly with the slot. To use it, I set the head of the bolt so it just barely grazes the saw blade at the front of the blade, as close to the teeth as possible. Then I slide it to the back of the blade and check again to see if any minor realignment is required.

*Sean Bree
New York, New York*



Duplicating Spindles

I made a bench with 13 spindles that had to be exact duplicates of each other, so I built a gauge by drilling several holes of varying sizes in a line along a piece of 1/4" hardboard. Then I ripped it down the middle. By marking the corresponding thicknesses on my turning blanks, I could simply stop the lathe, place my gauge on each of the marks and check my progress.

*James A. Johnson
Brunswick, Ohio*

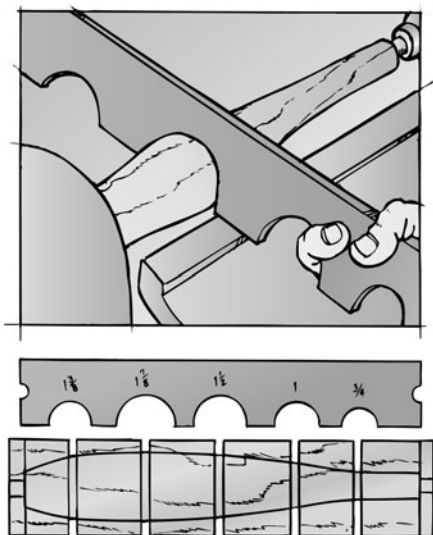

A Razor Edge on Turning Tools

Use a felt-tipped pen to coat the entire cutting edge of a tool and see how you're progressing while you sharpen it.

*Howard Moody
Upper Jay, New York*

Quick Tip

Keep a couple of hard-bristled toothbrushes handy in your shop and you'll find hundreds of uses for them. They're perfect for cleaning out carvings and intricate patterns when refinishing, or getting rid of dust and oil buildup on router bit bearings. They can be used to clean delicate parts where a wire brush would be too intrusive or coarse. And nothing works like a toothbrush and an air gun to clear dust from an inside corner before finishing.

Q&A

"How do I stop tearout in the underside of a veneered plywood sheet, when cross-cutting it on the table saw?"

By cutting it twice!

The first time through, set the blade height at 1/8", then make the cut slowly with a sharp, multi-tooth (at least 60 teeth) blade.

Then raise the blade and make the second cut all the way through. This method will eliminate almost all tearout problems. Putting masking tape along the cut line also helps a little.

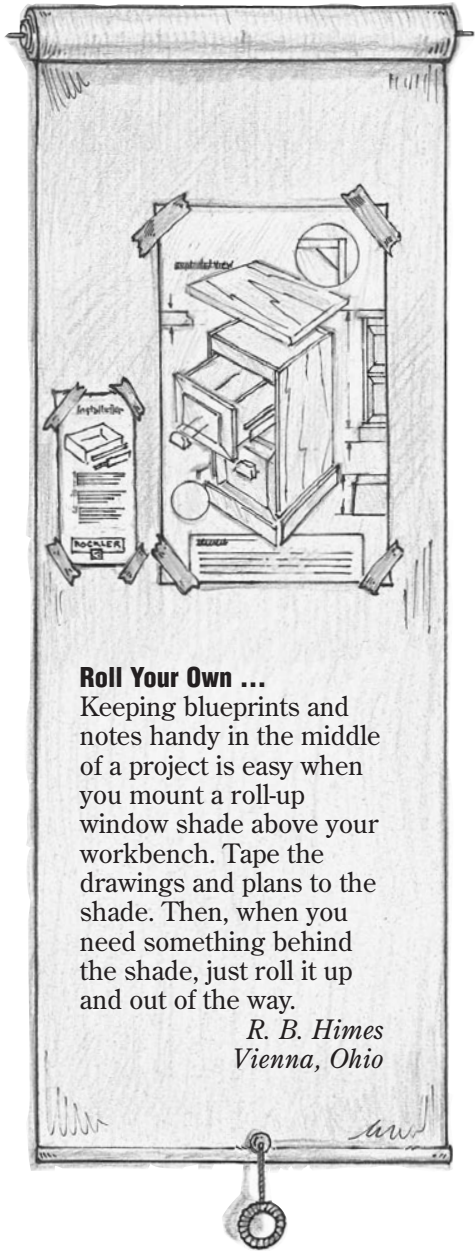

Roll Your Own ...

Keeping blueprints and notes handy in the middle of a project is easy when you mount a roll-up window shade above your workbench. Tape the drawings and plans to the shade. Then, when you need something behind the shade, just roll it up and out of the way.

*R. B. Himes
Vienna, Ohio*

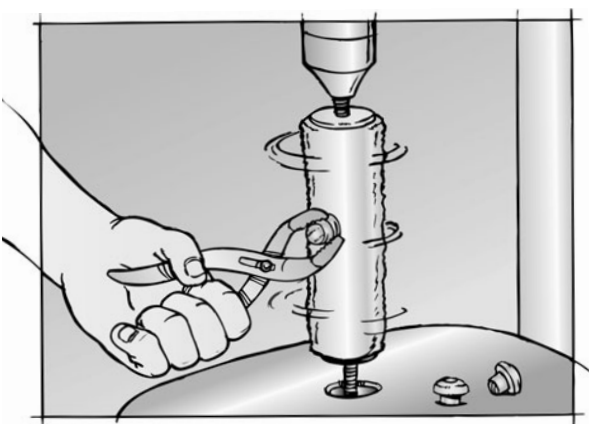
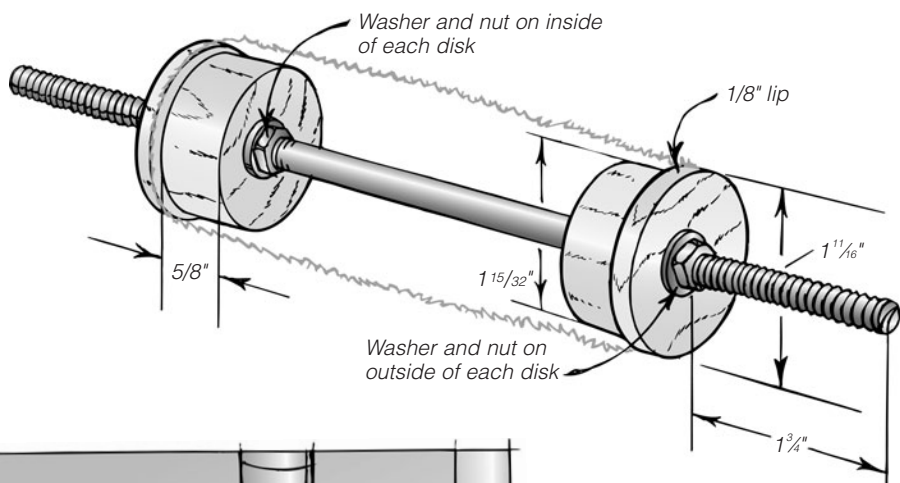

Build a Small Parts Buffer

Mount half a paint roller in your drill press or lathe to buff small parts. To do so, turn two $\frac{3}{4}$ " disks for the ends, leaving a $\frac{1}{8}$ " lip as shown above. Secure these on a length of threaded rod with nuts and bolts, spacing them just far enough apart to accept one half of a 9" long paint roller. Leave a couple of inches of rod for the chuck to bite. Clean the roller by wetting a cloth with paint thinner and holding it against the roller as it turns.

*William Robidoux Jr.
Tiverton, Rhode Island*

Quick Tip

When working with manufactured panels such as plywood and particle-board, store them flat or vertically, but never at an angle or they'll warp. They will de-laminate in damp or moist locations. If you need to plane their edges, start at the ends and work toward the middle: if your plane runs off the ends, you'll get some chipping and tearout.

Q&A

"How can I flute dowels?"

Flutes are cut into dowels to allow excess glue and pockets of trapped air to escape as the dowel joint is clamped shut. Several manufacturers offer pre-fluted dowels, but you can make your own in a pinch. Just drag a length of dowel sideways across one tooth of a circular saw blade. Make sure the blade is secured (as in a vise), and keep your hands away from the teeth. Two flutes are usually more than adequate.

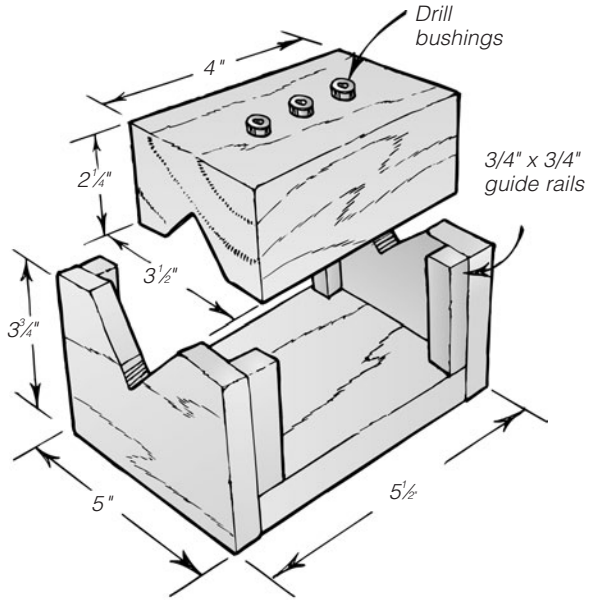

Drilling Center Holes

Here's an easy-to-build jig for drilling centered holes in round stock. The drill guide is a large block made by gluing up three pieces of stock, while the base is comprised of a glued up bottom, two ends and a pair of guide rails. Make sure the block moves freely in the base and use a slightly undersized bit when drilling holes for the 1/4", 5/16" and 3/8" ID bushings.

*Salvatore F. Pontecorvo
Fort Wayne, Indiana*

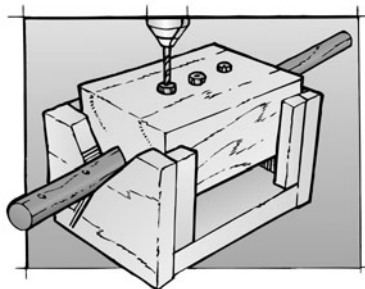

Shop Made Hold-downs

Here are two tricks to keep lumber tight to the saw tabletop (or a fence). The first is to cut a 30° kerf in a piece of plywood and insert a flexible putty knife, then clamp the unit to the fence. The second idea is a little more complex, as shown in the drawings below.

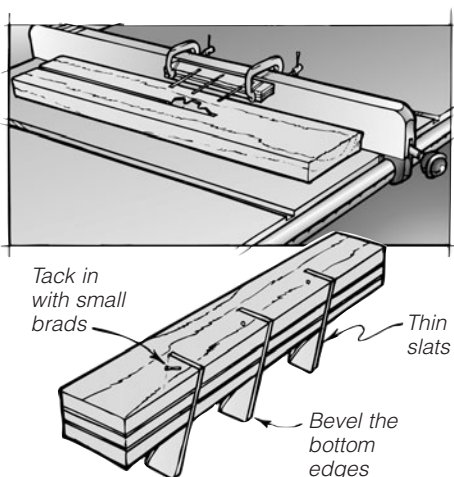

This is a piece of 3/4" plywood with kerfs long enough to hold wooden slats like paint stirring paddles. Glue and tack the slats in place after beveling the bottoms for better contact with the wood. The hold-down can be made any length or width: longer models work wonderfully when you're ripping long stock on the table saw.

*R.B.Himes
Vienna, Ohio*

Quick Tip

Spline joints are a great way to join two long edges.

But while most woodworkers have no problem routing the grooves for the spline, they often let the ball drop when it comes to making the actual spline.

A ripped piece of hardwood won't work, as it will split along the grain — right where you need the most strength. Plywood is the perfect answer: its alternating grain prevents splitting, and it comes in thicknesses that are perfectly suited to the router bits you use to make the grooves.

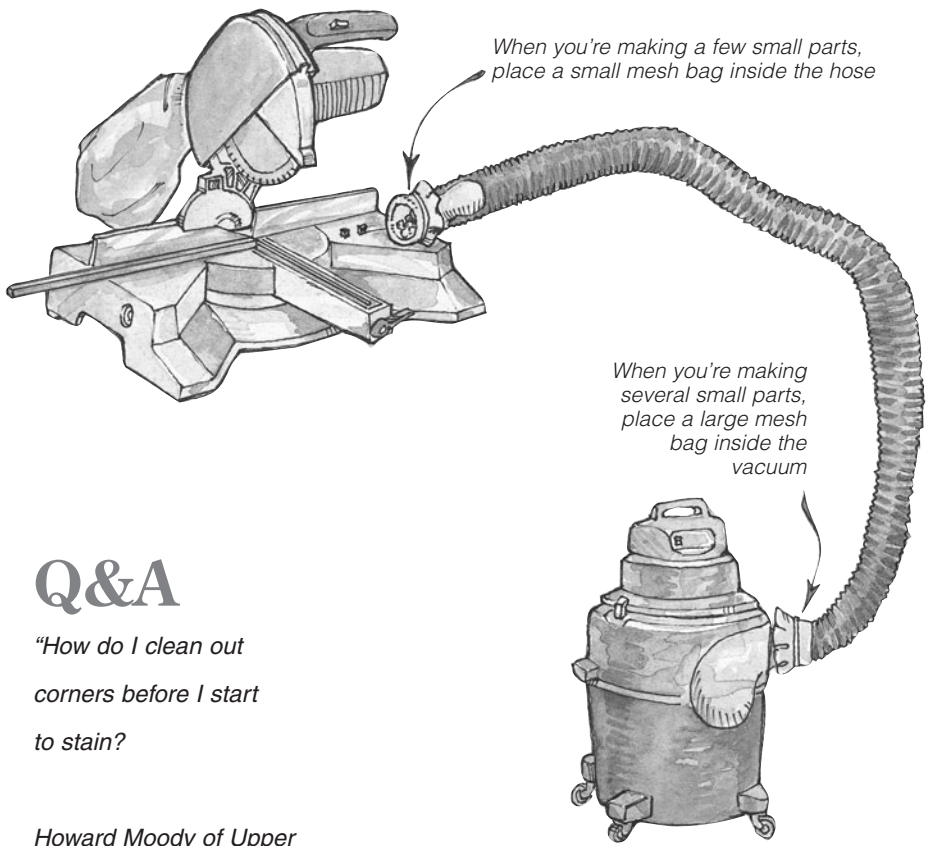

Q&A

"How do I clean out corners before I start to stain?"

Howard Moody of Upper Jay, New York, offers this simple solution: he buys a small whisk broom and reforms its flat bottom edge into a point. Howard tells us that his little custom brooms work great for those hard-to-reach corners, and they usually save him from dragging out the shop vacuum.

It's In the Bag

When cutting several small pieces on my miter or table saws, I put a mesh bag in the body of my shop vacuum and hold it in place with one end of the hose. I attach the other end of the hose close to my saw blade. When I turn on the vacuum and the saw, the vacuum pulls the sawdust into the body and the mesh bag traps the small pieces I'm making. If I only need a few parts, I put the mesh bag in the other end of the hose, near the saw.

*Stanley A. Pulaski
Cedar Springs, Michigan*

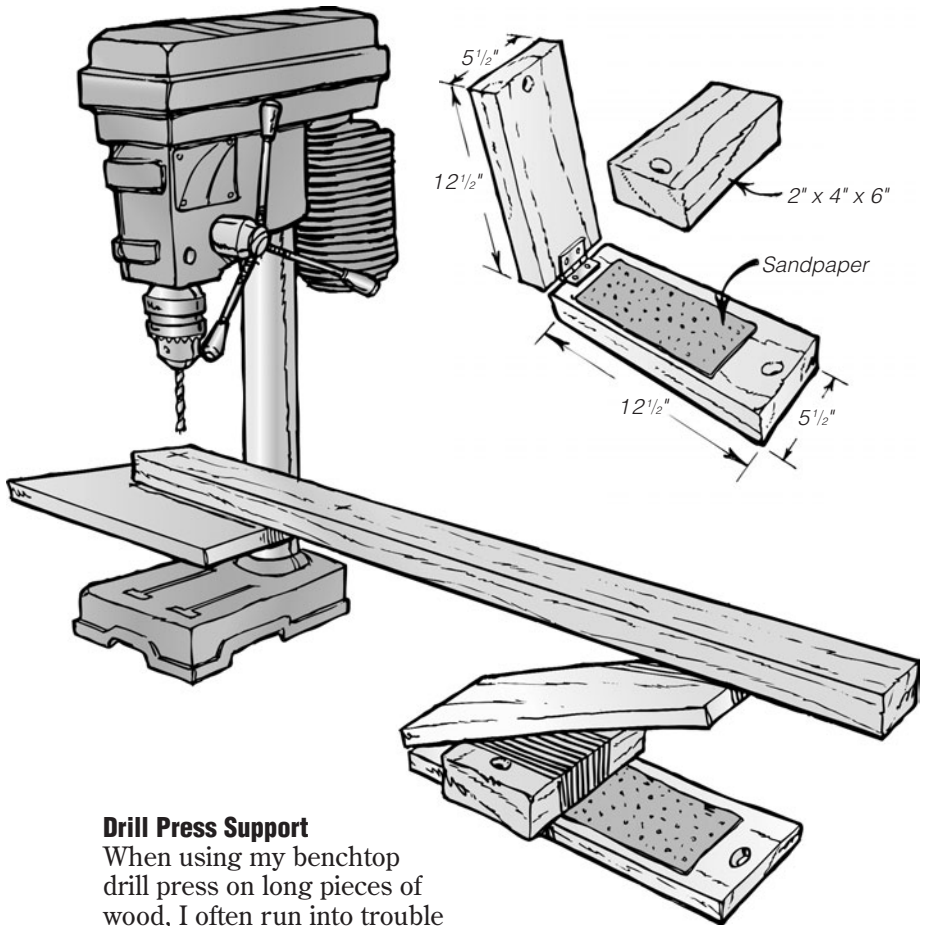

Drill Press Support

When using my benchtop drill press on long pieces of wood, I often run into trouble holding the stock level as I drill one end. So I made a simple support jig using two pieces of 3/4" plywood joined at one end with a butt hinge: this covers the full range of adjustment for my drill press table. A 6" long piece of scrap 2 x 4 serves as the adjusting block. It can be used flat or on edge, depending on the angle required. I glued a piece of medium grit sandpaper onto the lower flap of the jig, to keep the block from slipping when I put the weight of the stock on it.

*Bob Kelland
Newfoundland, Canada*

Quick Tip

When you spray lacquer in humid weather, a white blush reaction sometimes occurs. Roman Hershberger of Millersburg, Ohio, solves this problem by spraying a light mist of lacquer thinner on the blushing area.

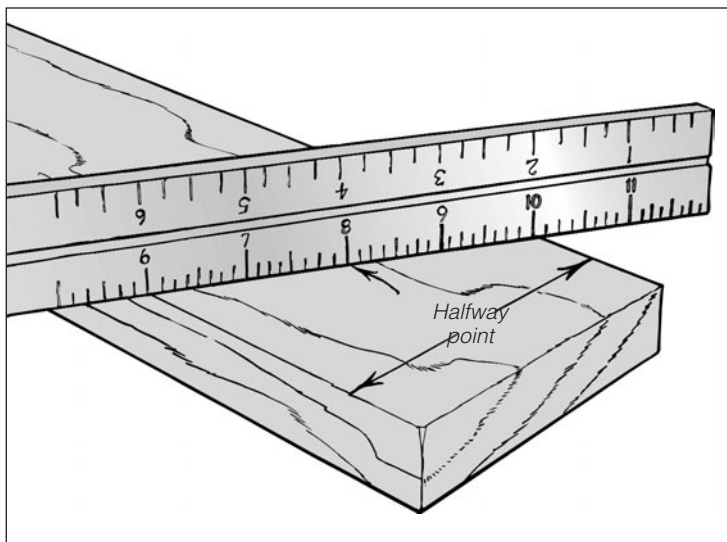

Q&A

“How do I avoid nicking the steel faceplate on my lathe when turning a bowl?”

Glue your turning blank to a disk of 3/4" thick wood the same diameter as the blank.

(Insert a page of newspaper between them before you glue and clamp them together: this makes separation after turning a lot easier.) Then simply screw the disk to the steel faceplate.

Short Cut to the Center

Problem: find the center of a $5 \frac{9}{16}$ " wide board. **Solution:** Place a square at an angle on your board, with the inch marks on edge. Rotate the square until two numbers that are easily divided in half are on the edges (in this case, 6 and 10; so the center of our board is at the 8" mark).

*Walter Keller
Fritch, Texas*

Straighten out those Curves

It's difficult to cut a curved line perfectly and, if you have cut away your marks, it's almost impossible to find exactly where the irregularities are. Try stretching a thin piece of band steel (or even an old band saw blade) along the curve. The exact position and severity of any irregularities will become immediately apparent.

*Michael Burton
Ogden, Utah*

Quick Tip

Storing Hand Planes

I wanted my hand planes to be within easy reach, but I also wanted to protect the cutting edges of their blades. So I built a modified tray that stores the planes right on my benchtop. The bottom is a scrap of plywood, and the sides are mitered stock left over from another project. Small strips of wood raise the fronts of the planes, keeping the blade edges clear of the bottom of the box. Angled strips underneath the tray prop up the entire assembly, and cross-strips stop the planes from sliding around, especially when I move the tray.

*Kevin Hemmingsen
Wabasha, Minnesota*

If you like the look of Honduras mahogany, but feel the price is a little steep, consider substituting clear Spanish cedar. When finished clear, it is very similar to mahogany – just as rich and deep, with quite a bit of character, too. The cedar is available in fairly wide boards (not as wide as mahogany), and it is a little lighter in weight.

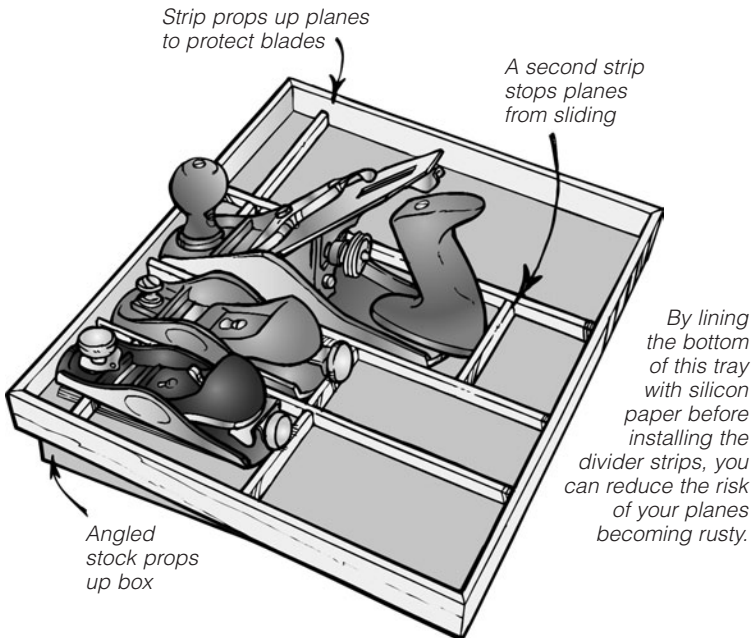

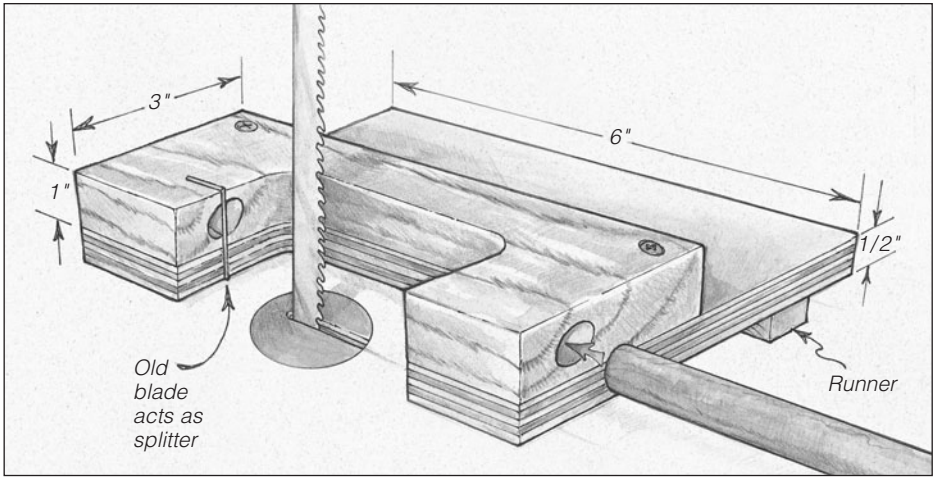

Q&A

"How do I get rid of large quantities of sawdust?"

Anyone who owns large animals would be delighted to get your sawdust for bedding. Just be sure you let them know what species you've been milling, and have them call their vet to make sure there are no problems. For example, horses have been known to get choleric when exposed to some species like walnut.

No-Twist Dowel Splitting

To split dowels on my band saw, I use guide blocks with holes drilled for each size dowel. These blocks are screwed to 1/2" plywood bases. Make a 2" x 2" cutout in the jig, then draw a line through the dowel guide hole and make a 1/4" deep band saw cut. Epoxy part of an old band saw blade into the cut, to prevent your dowels from twisting. A runner attached to the bottom of the base runs in the miter gauge slot and guides your cut.

*Don Kinnamon
Munds Park, Arizona*

Anti-static Dust Sweeping

Spray a little Static Guard on a soft brush to clean up fine dust when you sand between coats of finish. A light coat is all you need: too much will interfere with the finish.

*Roger Berg
Farmington, Wisconsin*

Green Stock Dryer

Too busy to paint the ends of a piece of green stock, I just tossed it in a box of shavings and forgot about it for several days. When I returned to it, there wasn't a single check in the end. Sawdust seems to draw out the moisture at a fast rate with no checks and little warpage. After initial drying in the dust, you can remove the stock and let it air dry. Sticks work best with the bark off. Just stir up the shavings every day or two so the moisture doesn't accumulate and grow mildew.

*Jeff Rose
Monticello, Minnesota*

Flat Out Fabulous

When working on carpentry rather than furniture projects, there are two good reasons to trade in your standard #2 pencil for the traditional carpenters' variety. First, the flat ones won't roll off a slanted surface like a roof. Second, the chiseled end tends to hold an edge longer than a pared point.

*John Tyler
Osceola, Wisconsin*

Turners' Fast Finish

Need a fast satin finish? Apply wipe-on polyurethane with a paper towel and immediately wipe it off while the piece is still spinning. This creates enough heat to quickly set the poly and bring out a beautiful satin finish.

*Ron Hampton
Texarkana, Texas*

Quick Tip

When turning a lid for a vessel, it's a good idea to make it a little too tight to start with, then remove it from the lathe and shave wood a hair at a time with a sander, file or chisel, for a nice, tight fit. Make sure both the lid and the opening are fully dry (about 6% moisture), or one may shrink at a different rate than the other: in that case, the lid will either stick or fall out. Watch the grain direction, too. Wood moves across the grain a lot more than it does along the grain, so your lid may fit in one direction, but turn it 90° and see if it still does before putting your tools away.

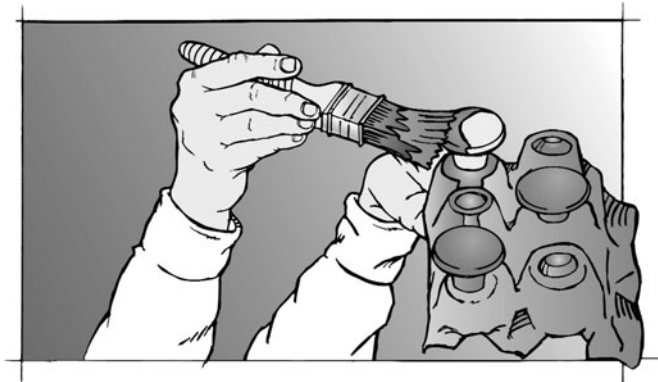

Q&A

"How do I space the boards on my picnic table equally?"

One of the oldest tricks in the shop is to drive a 16d nail through a small block of pine, then use this to create equal spacing on decks and outdoor furniture. The diameter of the nail produces roughly a 1/8" gap, perfect for rain and melting snow. The scrap of wood straddles both pieces of lumber as they're being secured, freeing up your hands.

Egg-cellent Solution ...

I use egg cartons to support knobs and such as I paint or finish them. Punch a small hole in the base of each recess in one half of a carton, then screw the knobs in place. Not only does this keep you and the workspace clean, it holds the knobs while they dry.

*Margie Kelland
St. John's, Newfoundland*

Stick Around

I have several stationary tools that need different wrenches to change bits or blades. I keep the right tool handy with large magnets from old stereo speakers.

*Richard Irvine
Gibsons, British Columbia*

Stick Around

I had a machine shop transform a \$10 garage sale table saw (minus a \$10 motor) into a router table with three steel inserts, and do it for just \$85. The saw fence works great with the router.

*Paul Dachel
Wisconsin Rapids, Wisconsin*

Slick Solution

I polish my table saw's top with clear shoe polish. It completely eliminates resistance and doesn't stick to wood.

*Roger Berg
Farmington, Wisconsin*

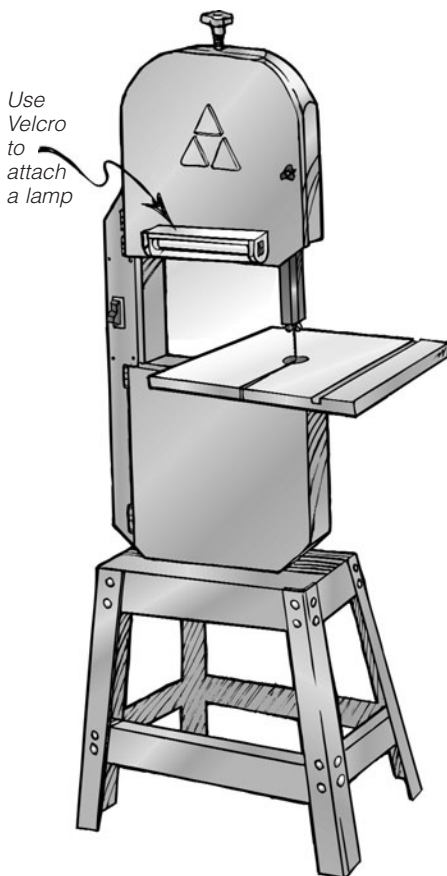

Let There be Light

I equipped my band saw with a little 6" fluorescent lamp that runs on AA batteries. I attached it with Velcro® and placed strips in other strategic spots around the shop. Now I have light wherever I need it.

*Lawrence Heinonen
Burlington, Michigan*

Quick Tip

Large assemblies with numerous parts can quickly get out of hand, so the pros know the value of a storyboard to keep everything organized. This can be as simple as a large sheet of paper or hardboard laid on the workbench, with a full-size template drawn on it. The template shows how the parts will be oriented to each other after assembly, and a good template can even be used to take measurements while you cut parts to size. Hot glue small guide blocks to the template, to help line up the larger parts.

Q&A

“What’s the difference between a dado, a rabbet and a groove?”

All three are rectangular grooves in wood. A dado runs across the grain, while a groove runs along the grain. A rabbet runs along the edge of a board.

Holder for a Drafting Lamp

Here’s an idea that works on any workbench equipped with bench dog holes. Just take a piece of 2 x 4 and drill two holes several inches apart. One should fit the lamp base, while the other should be the same diameter as a bench dog. Glue a dowel into the second hole and you can mount your lamp anywhere on the benchtop. The hinged arm on the lamp allows you to light up just about any project.

*Harold A. Hubbard
Berkeley, California*

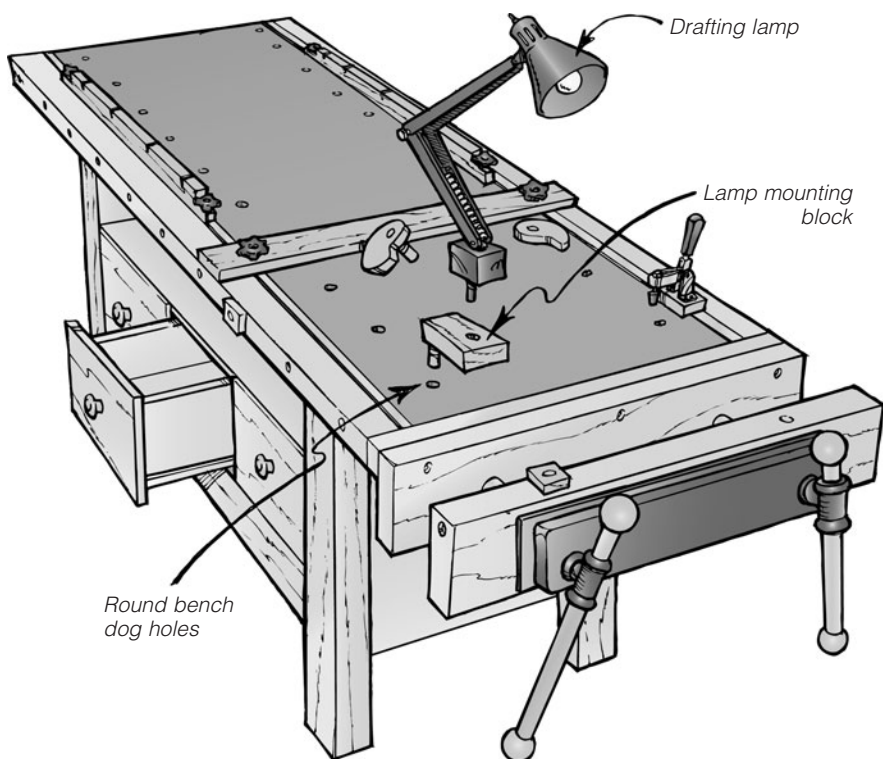

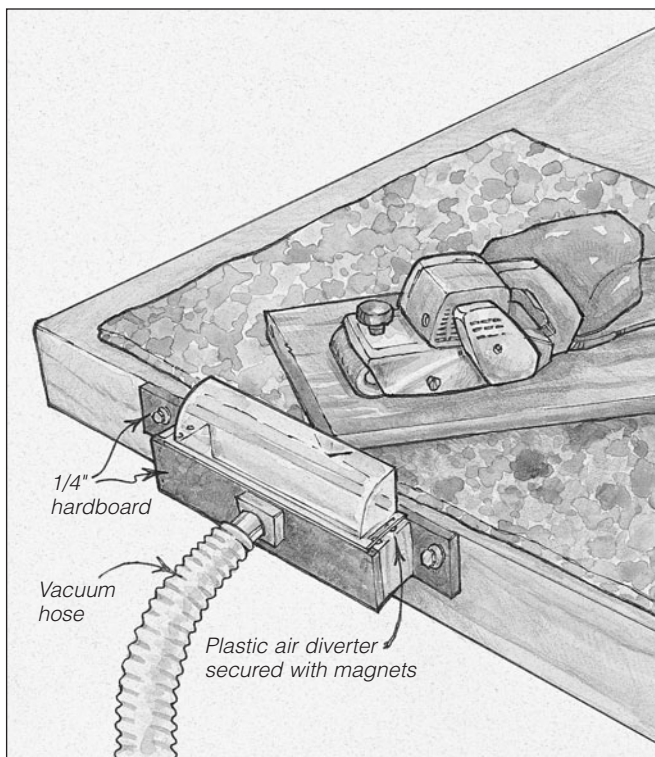

Inexpensive Dust Collection

I devised a dust catcher from a plastic register air diverter. These diverters come with magnets, so they can be mounted and removed in seconds. The hood attaches to a small box featuring a couple of 20d nails for the magnets to grab.

*R. B. Himes
Vienna, Ohio*

Legal-sized Tools

An old metal file cabinet makes a safe, dust-free storage device for power tools. And you can even organize them alphabetically!

*Shay Thomas
Somerset, Wisconsin*

Quick Tip

Those yellow, self-sticking notes that adorn every inch of the wall space in most office cubicles also come in a small size. It fits perfectly on the side of a 20-ft. tape measure — a real boon when you have several measurements to remember.

Q&A

"How can I make several identical small parts?"

The answer is template routing. Secure a 1/4" hardboard template to each blank in turn with two-sided tape, then use a bearing guided router bit (with the bearing on top) to cut the blank to shape. The bearing runs along the template. We suggest reading more about this technique before trying it, as it can be quite tricky.

Magnetic Catches for Small Boxes

Recently a friend asked me to make a box for his Irish flute. It needed to be free of outside projections, including hinges. Setting magnets into the box to secure the lid properly was my solution. I chopped three opposing mortises in the top and bottom edges of the box, and then epoxied the magnets in place. A strong and simple solution.

*William Andersen
Chapel Hill, North Carolina*

Keep Panels from Buckling

Here's a way to keep panels from buckling when they're edge-glued and clamped. I make custom end caps by plowing grooves in a couple of 2x4s the same dimension as the panel stock. So far, I haven't had a problem with the caps getting glued in place.

*William P. Nichols
Ravenna, Ohio*

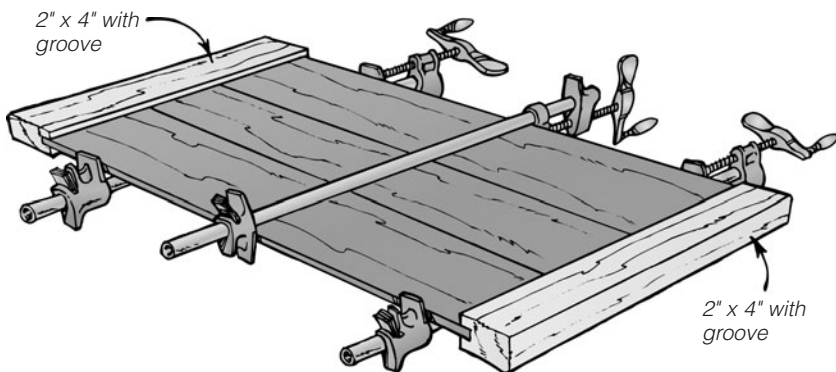

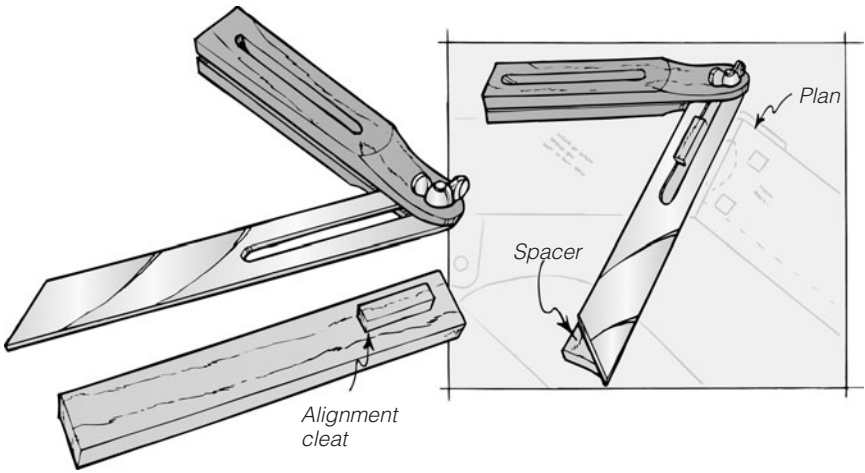

Sliding Jig for T-bevel

When I needed to transfer angles from a plan to my workpiece, I lost accuracy because the T-bevel wouldn't lie flat. So I made a spacer the same width as the bevel blade. I added an alignment cleat that rides in the blade slot.

*Bob Kelland
St. John's, Newfoundland*

Reduce Tearout

Remove finish nails from a board by pulling them through with a pliers, rather than hammering them back out. You'll get less tearout.

*Roger Berg
Farmington, Wisconsin*

Raising More than a Panel

Stain raised panels before you install them in their frames. Otherwise, there will be an unstained line at the edges if the panel shrinks.

*John Tyler
Osceola, Wisconsin*

Quick Tip

Your local sawmill may be a great source for inexpensive lumber, but moisture can be a problem. Most small mills pile up logs and store them out in the weather. When they rip them into boards, they usually store these outside in unprotected stickered stacks. Bring a moisture meter with you, and cross-cut a board to test it: don't test exposed ends. Accept boards with 6% to 12% moisture content.

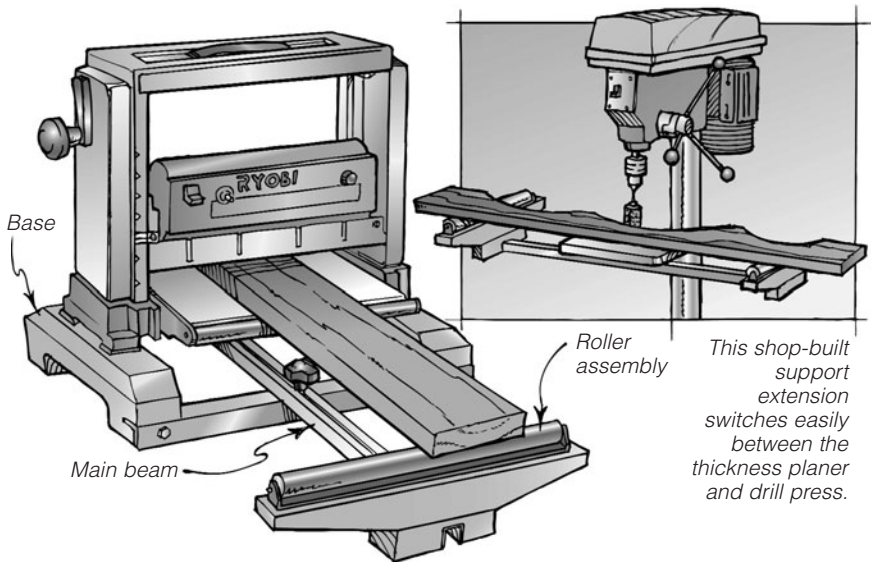

Q&A

"Is there an easy way to chop through mortises without a mortising machine or drill press attachment?"

Through mortises house a tenon that reaches all the way through the mortise and out the other side. They can often be made by cutting a shallow dado in each half of a leg (or other furniture part), then gluing the two halves together.

Make Your Own Support Extensions

The main component of this support system is a square tube attached to the drill press with two carriage bolts and T-knobs, or to the planer with two threaded T-knobs. The roller assemblies are always level and move vertically with the drill press table. The roller assembly is mounted on a support made of two pieces of 3/4" stock glued together, then mounted on the square tube. With the exception of the rollers, the entire system cost less than \$10.

*Raymond P. Cetnar
Amsterdam, New York*

Here's a Good Point

Use a standard push pin from your bulletin board to transfer patterns from paper to wood. Just tape the pattern in place, then prick through it into the wood every 1/4" or so.

*Charlotte Cole
Watertown, South Dakota*

Plugging Holes in Premium Wood

To shave wood plugs absolutely flush, cut five pieces of paper to fit in the opening in your router base. Stack the paper and adjust a flat bit's height so it barely touches the top paper. Now run the router across the plug. If the bit still needs to come down, remove a couple of papers and repeat the adjustment until the plug is barely above the surface. Finish with a light sanding.

*James A. Johnson
Brunswick, Ohio*

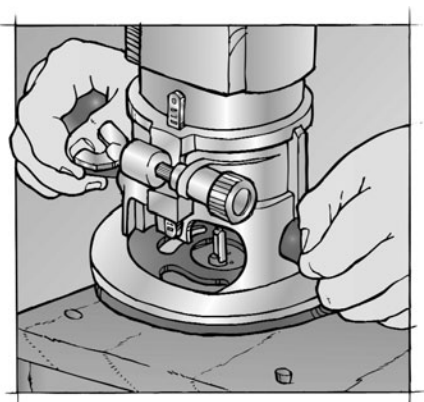

Straight-up Chiseling

For chopping out waste in joinery, I use a chisel block to keep my chisel vertical. This is a hardwood block (about 2" thick) with a sandpaper bottom to keep it from moving. One bottom edge has a 1/4" chamfer, so my scribe line stays visible.

*Nina Childs Johnson
(from a Woodworker's Journal article)*

Quick Tip

You can significantly improve the quality of a rubbed glue joint (two boards joined on edge) by putting a pencil mark on the top of each board, then running them through the jointer. Keep one board's mark against the fence, and the other away from it. Then, if the jointer is even the tiniest bit out of alignment, the two cuts will compensate each other. Turn one board end-for-end, apply glue, and press them together: this will spread the glue more evenly. Then realign the boards correctly before clamping.

Q&A

“My air compressor just won’t work on an extension cord. Any ideas?”

The manufacturer’s instructions on most small compressors tell you to use a long air hose instead of an extension cord, because the latter can lower the amperage and damage the compressor’s air pump.

Don’t Wiggle your Joint

Never wiggle joints apart after a dry fit, as this will crush the wood fibers and cause a loose fit. Instead, use a mallet and a scrap block to tap the joint apart.

*Nina Childs Johnson
(from a Woodworker’s Journal article)*

Miter Jig

My contractor’s saw needed help to cut accurate miters, so I built this jig. Start with a keyed platform that rides in one miter gauge slot, and run it through the blade to trim it. Make an angled platform at 48° (no, that’s not a misprint), then screw a fence to this at 90° to the blade. Tilt the blade until you have a perfect 45° angle, and remember to reset it to 90° when you’re done.

*Carl Allen
Oswego, New York*

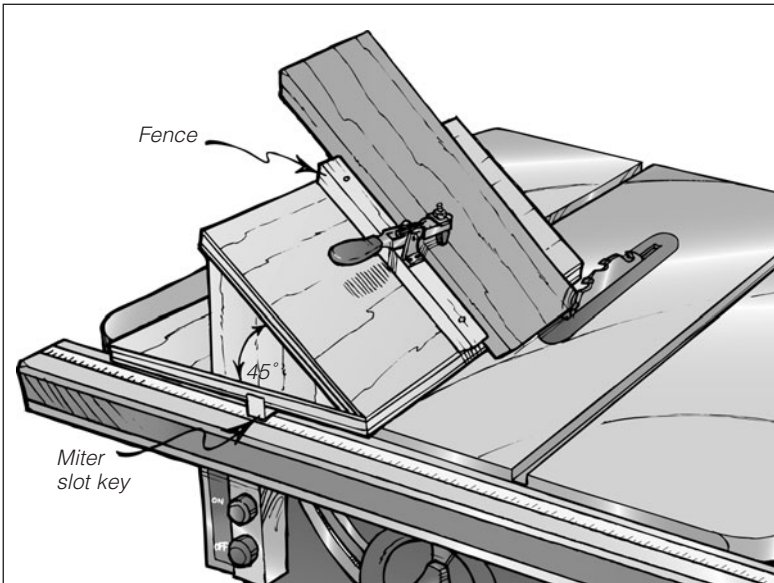

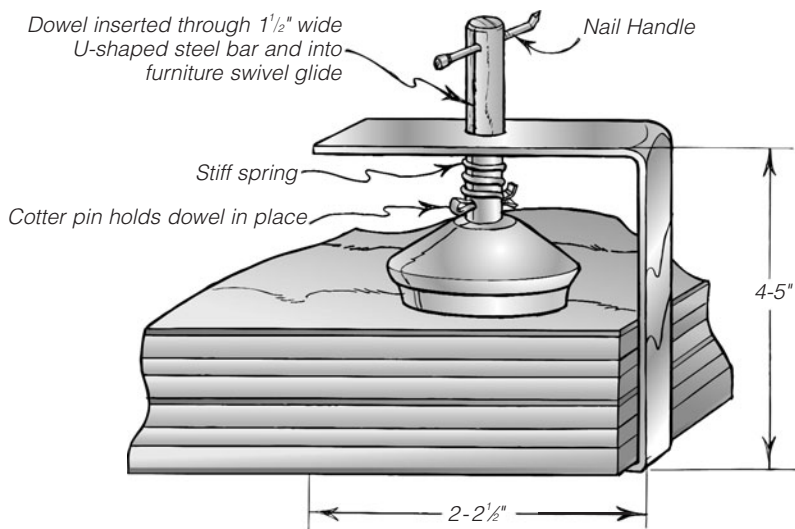

Shop Built Clamps

It may be true that you can't have too many clamps, but they do get expensive! Using affordable items (springs, dowels, cotter pins and steel bars), I have crafted several versatile little clamps that work quite well for attaching trim and doing other light-duty jobs.

*R. B. Himes
Vienna, Ohio*

Magnify to Look Sharp

As you prepare to sharpen tools, set out the strop, stones, lubricant ... and a magnifying glass, loupe or optivisor! Being able to see and evaluate the cutting edge you are sharpening is as important as your technique. Often, what seems like a sharp edge will, under magnification, look more like a saw.

*Michael Burton
Ogden, Utah*

Quick Tip

As dust flies through your collector hoses, it builds up static electricity on the walls. To prevent sparks (and even explosions), you should ground metal hoses by attaching a piece of plastic-covered copper wire to the hose and a cold water pipe (or similar ground). Run bare wire through plastic hoses and ground one end of this in the same fashion.

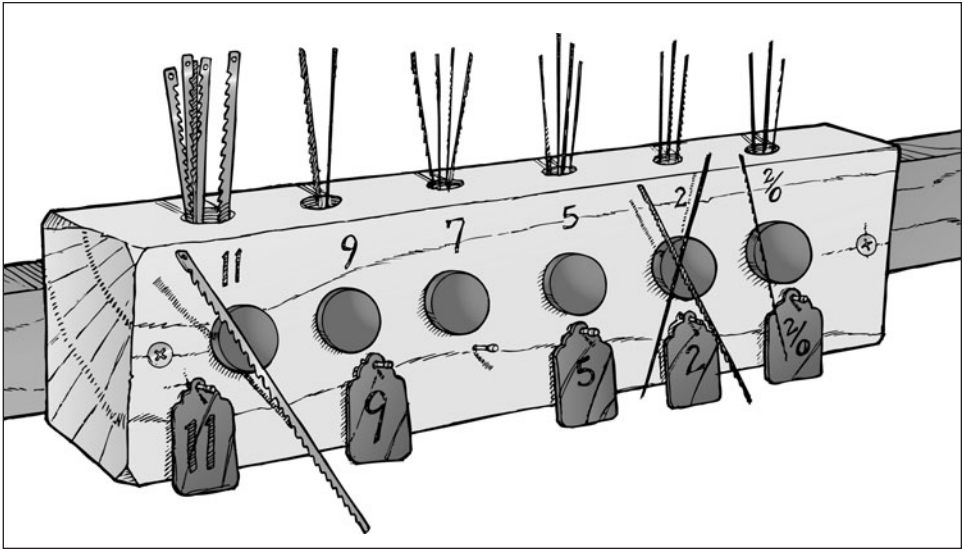

Q&A

“Can I use 3-phase stationary tools in my shop?”

3-phase current supplies a lot more amperage

(power), so it's the norm in large commercial shops.

Home shops generally don't have this option, but it's possible to buy a converter to step standard household current up to 3-phase.

Memory Magnets

I built this simple jig to organize my scroll saw blades. Whenever I install a blade, I attach the relevant number tag to the saw. When I get back to it a week or so later, I can immediately tell what number blade is installed. When I change blades, I stick the used one to the magnet in front of the correct hole, so it doesn't get mixed up with brand new blades.

*Art Gustafson
Cobleskill, New York*

Carpet Tape to the Rescue

If you run out of adhesive-backed sanding disks, you can make your own in a pinch with two-sided carpet tape and standard sandpaper. Trim along the edge of the metal disk with a utility knife before using it.

*Edward Daniel, Jr.
Davenport, Iowa*

Project Support

With a roller, a knob with threaded 3/8" stub, a 3/8" insert, some screws and scrap hardwood, I constructed a stand to support long projects being drilled on my benchtop drill press. The base of the support has a square opening about 1/16" larger than the support piece on either side, so the support will easily slide into the base. To provide for varying heights, a knob with a 1/8" threaded stub presses a moveable block against the support. I installed a threaded metal insert in the front block. To minimize wear, I epoxied a shoulder washer with a small hole to the moveable block. The top platform holds the roller while extending about 1/2" on each end.

*Paul Feldker
Waterloo, Illinois*

Quick Tip

Frame and panel doors don't just look pretty: they also perform a vital function.

A free-floating panel is just about the only way to accommodate movement, especially when you're working in solid hardwoods.

Resolving the movement issue is critical when the doors are inset: if they expand, you won't be able to open them until winter!

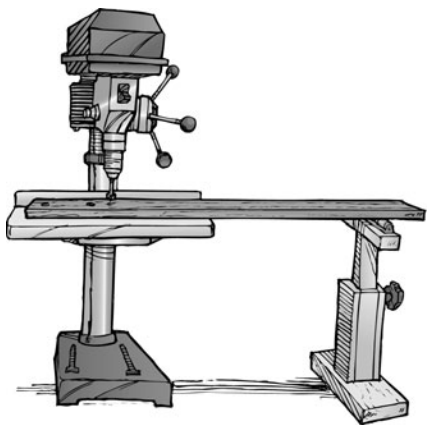

This benchtop jig supports long boards on the drill press

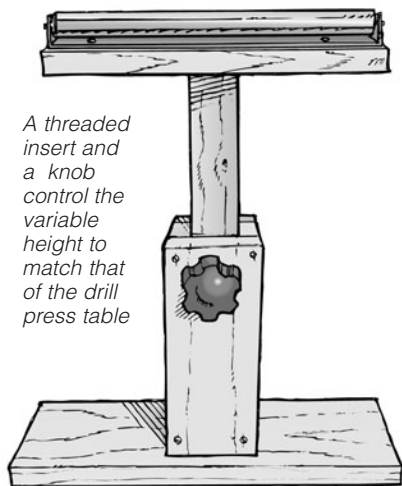

A threaded insert and a knob control the variable height to match that of the drill press table

Q&A

"Why use a veneered panel instead of edge-glued solid hardwood boards?"

A clear hardwood log yields thirty square feet of veneer to every board foot of lumber, so it's more economical. Plus, on an MDF or plywood core, veneer is dimensionally stable. Because of that, veneer panels can be used as structural elements like legs, doors and tabletops, and not just for decoration: they will carry a load without moving.

Safer Panel Raising

Raising panels with a router bit can be pretty scary, unless you use a vertical bit that is partially buried in the fence. With these, you'll get the best results when you remove no more stock than 3/32" per pass.

*Howard Blanding
Somerset, Wisconsin*

Spin for a Drill Bit

Here's a drill bit holder design that makes it easy to pick out any bit with a spin. I'm legally blind, but I can still see the numbers on the edge of the lazy Susan. So far, I have three different types of bits and each has its own color-coded lazy Susan, together with a drill gauge in the center to help me select the right bit every time.

*Bernard C. Wiklund
Minneapolis, Minnesota*

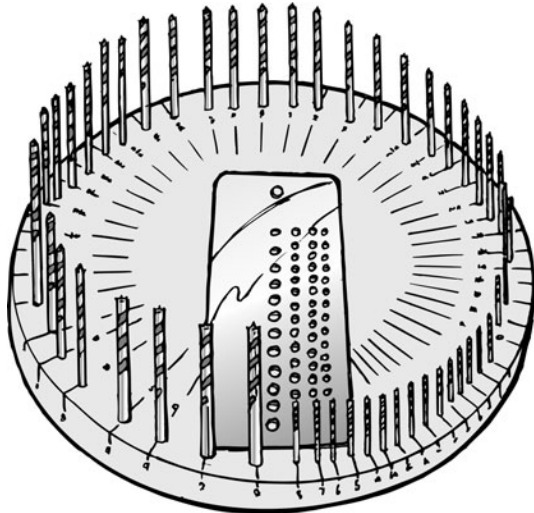

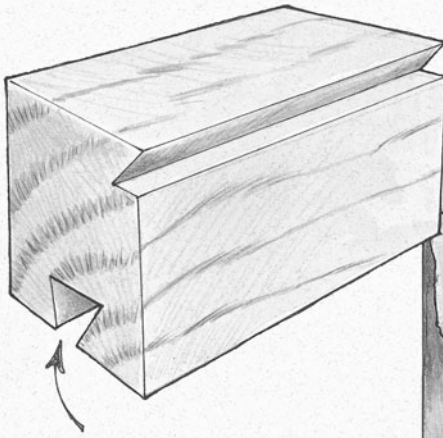

The groove size is based on the router bit you use for dovetails and the thickness of the material you'll be working with. It's easy to make more than one guide block for differently sized keys

To get a perfect tail setup, use your guide block to establish your router table's fence position and to set the height of the bit

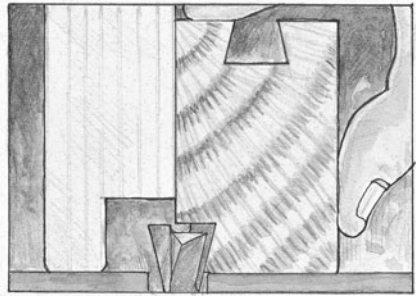
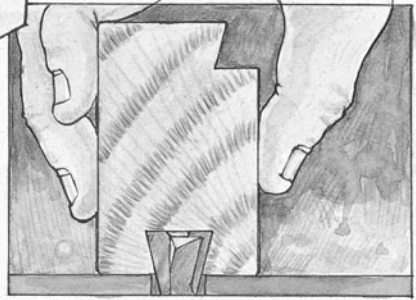

The Key to Sliding Dovetails

Sliding dovetails make a great joint. There's a lot of gluing surface, they look great, and they hold forever. But they can be tricky to set up, unless you use a key. Making one is simplicity itself: just mill both the groove and the tail of a dovetail joint in the same hardwood scrap. Make one for each dovetail bit you own. Use a stable, tight-grained hardwood that won't expand or contract much, or even a piece of high density fiberboard. Now, instead of starting from scratch each time, you can just use the key to set the fence and the bit height.

*R. B. Himes
Vienna, Ohio*

Quick Tip

Between shop sessions, you can seal the top of your glue bottle with a sandwich bag (squeeze out the air first) and a rubber band.

Use the band to store the bag on the side of the bottle during use.

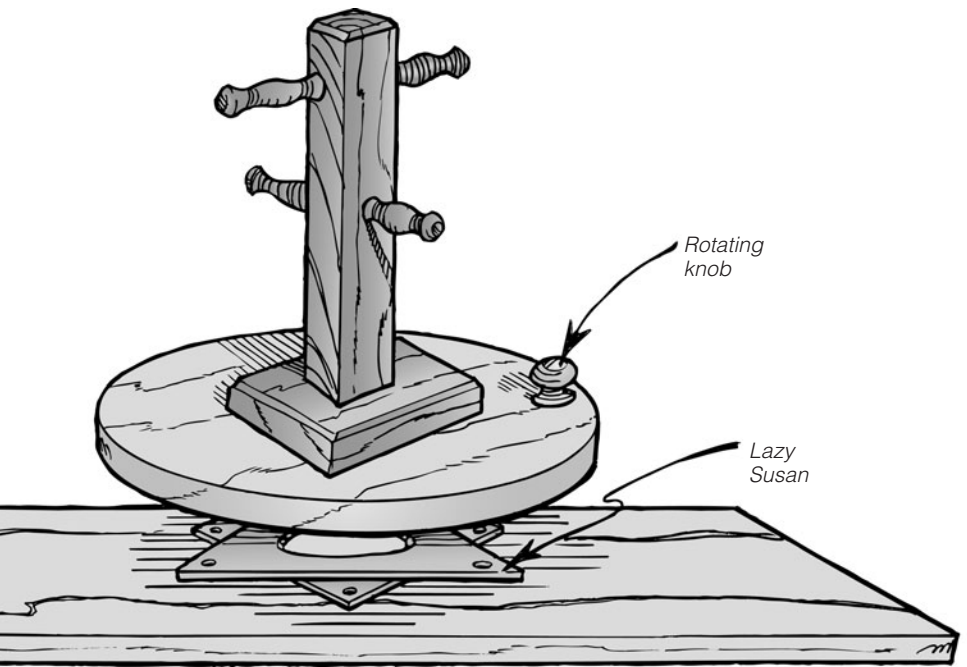

Q&A

"I stained and lacquered my cabinet doors, but they're too light. What do I do?"

Mix some darker aniline dye into the lacquer, and apply another topcoat. Try it on some scrap first, then experiment on the backs of the doors, before applying it to the visible faces.

Finishing Carousel

An old retractable TV shelf with a lazy Susan makes an ideal finishing jig. Secure a 16" diameter plywood disk to the top, and you're ready to go to work.

*Robert O. Wendel
Marlboro, New Jersey*

Roll out the Paintbrush...

I often line the small boxes I make with felt. After spraying adhesive, I press the material onto the drawer bottom using what was once the handle of a "throwaway" paint brush. I cut it off just above the metal ferrule and then round over the edges to make a felt-friendly roller.

*Ann Erlich
Long Beach, California*

Twine Around your Laminate

Rather than fuss with dowels or shims when applying laminate, I use heavy twine (like the post office kind) to separate the two surfaces that have been coated with contact cement.

*Frank Wyatt
Galax, Virginia*

A Pin in the Hole Stops Slips

If the back saw in your manual miter box likes to jump out of the guide during the backstroke, pop a cotter pin in the hanging hole in the blade.

*C. M. Wegner
Bloomington, Minnesota*

Recycle a Circular Saw Base

When your circular saw gives out, save the base and recycle it as an adjustable guide for your drill press.

*Ralph Wilkes
Penn Yan, New York*

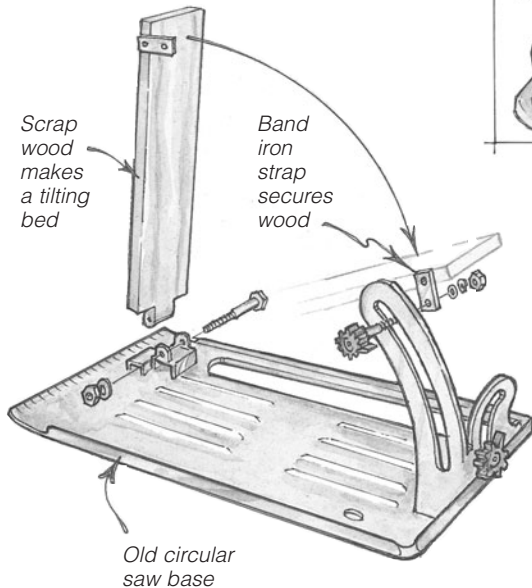

Quick Tip

To measure a museum piece, take a 35mm slide of it and measure one part (say, a 30" long leg). At home, you can adjust your projector and screen until the image of that leg is 30". Then all the other parts will be full scale.

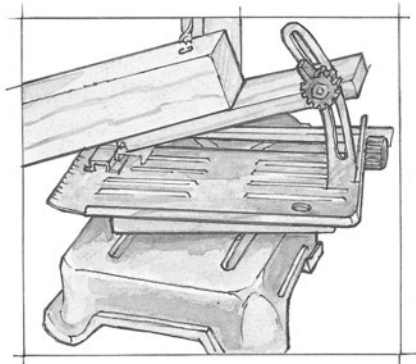

Notch the end of the scrap hardwood tilting bed to fit the hinge cradle on the old circular saw base, then drill a hole through the tongue you created, for a bolt.

Permanently tighten the bevel adjusting knob to keep the tilting bed in a horizontal position.

Q&A

“What is a quartersawn board?”

Imagine looking at the end of a large log. Now, think of cutting a 1x10 board out of that log, where one 1" edge of the board is at the center of the log, and the other is out near the bark. The wide (10") face of this board would have a long, tight, straight grain pattern with no crowns: this makes it very stable — it doesn't move much in humidity or temperature changes, so it's ideal for furniture building. A more common plain sawn board is cut at 90° to the quartersawn board (a much more economical way to mill), so it has crowns in its wide grain pattern.

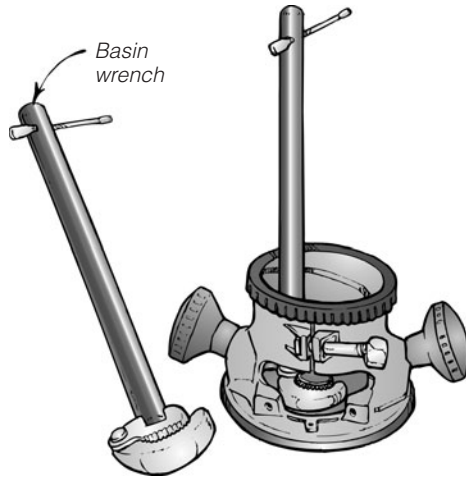

Tightening Guide Nuts

When I have trouble tightening the locking nuts on my router guides, it's time to get out the basin wrench. I find it saves time, and wear and tear on my knuckles.

*Jack Zabel
Cedar Falls, Iowa*

Another Pitch for Baking Soda

Here is an environmentally responsible way to clean pitch from saw blades and router bits. In a plastic dishpan, with an inch of boiling water to cover the blade, I sprinkle a couple of tablespoons of baking soda around the perimeter of the blade. Within a minute the pitch is gone. I remove heavier deposits with a nail brush charged with baking soda, then dry with a hair dryer. Now, my bits and the environment are both a little cleaner.

*Dennis DiVito
Buena Vista, Virginia*

The Best Use for a Credit Card

I like to spread glue with an old credit card, after first trimming one end with a pair of pinking shears. The notches leave ribbons of glue that spread evenly when pressure is applied. This works wonderfully on large areas, such as when two boards are face-glued together.

*Larry Heinonen
Burlington, Michigan*

We Brake for Broken Screws!

We use a 5" length of 1/4" steel brake line in a drill to cut around finish nails and broken screws. A three-corner file is used to make pointed notches in one end of the tube, and these teeth cut down around the fastener. In a reversible drill, the tube sometimes reverses broken screws right out. Then we re-drill for a matching 3/8" wood plug and complete the repair.

*Robert and Alice Tupper
Canton, South Dakota*

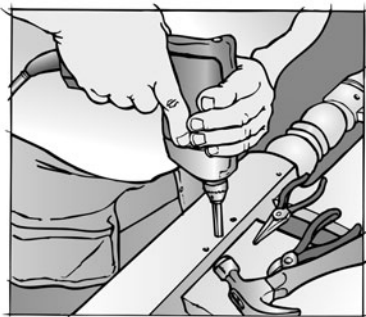
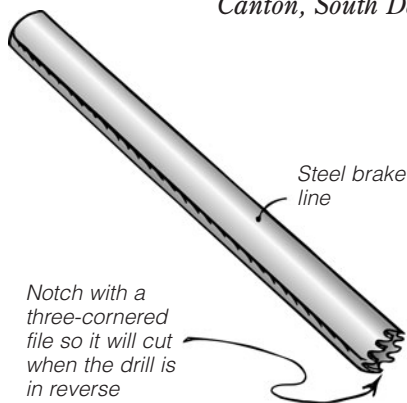

Quick Tip

Resawing makes two thin boards (say, 5/16") out of one thick one (3/4"). It's usually done on the band saw with a stiff 1/2" or 5/8" blade. The best way to guide the board is to clamp a point fence to the saw. That's just a V-shaped fence, where the point is positioned the thickness of the resawn board (5/16") away from the blade. The idea is to keep the board vertical.

Q&A

"Is there any maintenance I should be doing on my air compressor?"

Yes. You should drain it after every use (more frequently on humid days with heavy use), and you should place one drop of oil in your nail gun's coupler every time you attach it to the air hose.

Keeping Pencils Handy

I keep a 1x2 slab of styrofoam near my drill press to store pencils close to my work. I just stab them into it. I also use the slab when working with screws, so they don't get lost.

*George Suchy
Bradley, Illinois*

PVC Collet Couples Vacuum Hose

The 2" dust port on my stationary sander didn't fit my ShopVac® hose. A short piece of schedule 40 PVC provided the solution. Several 2" saw kerfs turned one end into a collet that could securely grab the dust port. The other end was just the right size to fit the ShopVac hose.

*J. David Carlson
Cary, North Carolina*

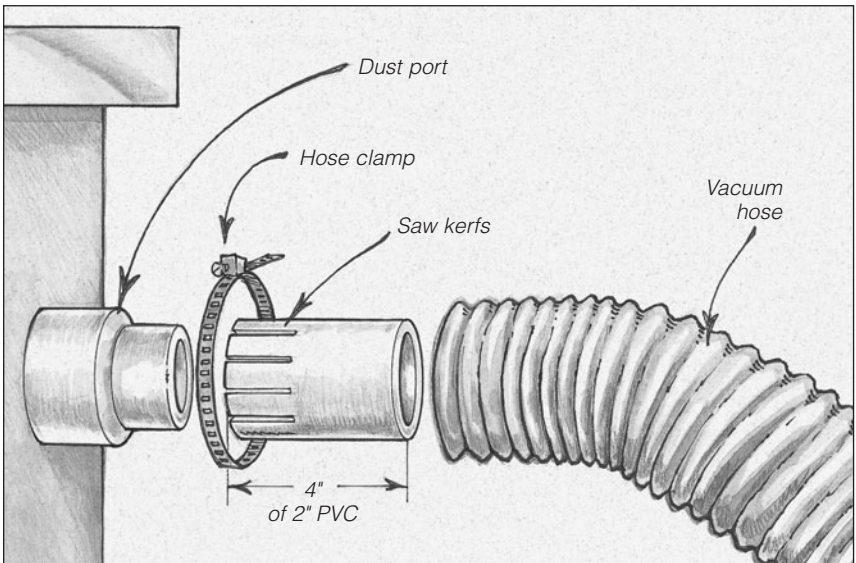

Teflon Keeps Finish Fresh

While clear glass jars are handy for storing finishes, the caps often seal to the jar so opening them becomes both difficult and dangerous.

I found a simple solution: Teflon tape – the kind plumbers use.

I wipe the top of the jar clean, then wrap a couple of layers of tape over the threads, going in the same direction the cap turns. I even let some tape lap over the top lip of the container. Most finishes and paints won't stick to the tape, so opening the jar becomes easy.



*Howard E. Moody
Upper Jay, New York*

New Use for Old Putty Knife

I had a 2" putty knife with a stiff blade that I never used, so I applied 2-sided tape to the blade and stuck two different grades of sandpaper to it. Now I can clean up in tight spots.

*Joe Cormier
Peabody, Massachusetts*

Stable Straightedge

I made several stable straightedges by laminating strips of poplar and Philippine mahogany. I use them as winding sticks: the mix of dark and light woods shows up any problems.

*Harold A. Hubbard
Berkeley, California*

Quick Tip

Small, thin moldings can be quite hazardous when you try to mill them on a router, shaper or table saw. They are so light that the cutter can grab them and pull them out of your control in a split second, or shatter them and send pieces into orbit. The safest way to make a small molding is to mill it on the edge of a wide board, then just rip it to width on the table saw. Always keep the small cutoff on the side of the blade that's furthest from the fence, so it doesn't bind.

Q&A

“Why do the nails in my air gun keep blowing out the sides of my cabinets?”

Pneumatic nails are flat and two-sided, so they have a natural tendency to follow the grain. To prevent this, rotate the gun 90° so the nail head cuts across the grain. Another common cause of blow-out is driving nails that are simply too large for the application. You may want to try down-sizing, and see if that helps. You could also check the pressure you're using: it may be too high.

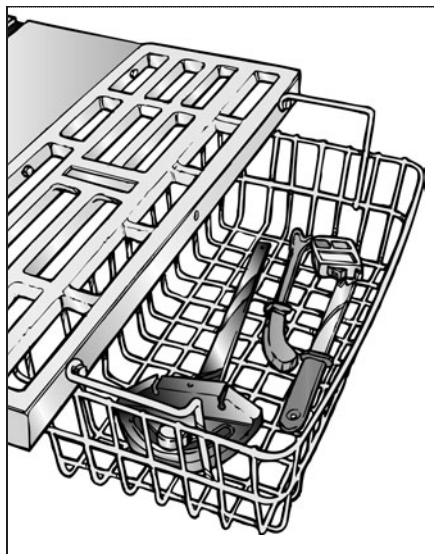

Storage for Accessories

If you fasten a metal mesh basket to the underside of your table saw, you'll have an excellent place to keep the miter gauge and push sticks — things that never seem to be handy when you need them. The mesh lets sawdust fall through, too.

*Fred Boczek
DuBois, Illinois*

Free CDs are a Big Hit

I used to be annoyed when those free Internet CDs arrived in the junk mail, but now I look forward to them. They make great shims for a wobbly workbench, trim protectors when you're painting a patch in the wall, glue spreaders, and a hundred other little shop helpers.

*Roger Berg
Farmington, Wisconsin*

Let Dyes Dissolve

Water-based aniline dyes have become increasingly popular in these environmentally-conscious days. These are colored powders that are dissolved in water, so large batches of stain can be made at very little expense. However, it's important to let the dye sit for an hour or two as some powders may take these that long to dissolve and yield their final color.

*John Tancabel
St. Paul, Minnesota*

Use this quick and simple depth gauge when you need to know the exact depth of a hole or mortise

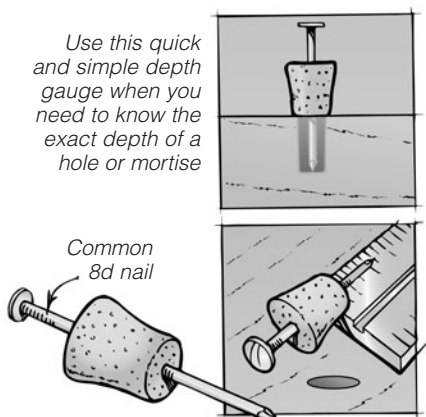

Poor Man's Depth Gauge

You can save a few bucks and make a fairly accurate depth gauge with a nail and a wine bottle cork. Set the cork on the surface and run the nail down through it until its point hits the bottom of the hole you're measuring.

*R. B. Himes
Vienna, Ohio*

Quick Tip

Kiln-dried lumber can produce a lot of surprises if the operator doesn't know what he's doing. One of the most common defects, case-hardening, is the result of too rapid drying. The outside of each board dries quickly, causing the moisture in the center to be trapped. This moisture heats up, expands, and causes the wood to split (or "honeycomb") and virtually disintegrate. If you're buying a large load of freshly kilned lumber, ask the operator to rip one or two boards down their center, to check for case-hardening.

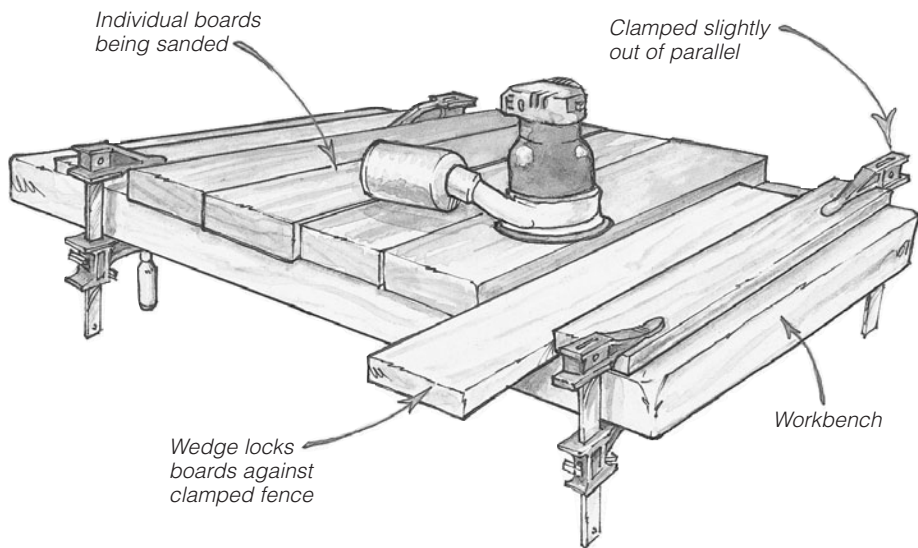

Sanding Jig for Multiple Boards

When I need to sand several boards of the same size, I clamp two fences to my bench, leaving one at a very slight angle to the other. Then I load up the boards and wedge them in place with a piece of scrap. It makes for very quick board changes, which is great on big jobs. Just make sure the fences and wedge are thinner than the boards being sanded.

*Robert Jobsky
Goleta, California*

Q&A

"How do I get a good glue bond with oily woods like teak?"

Start by rubbing the glue area with acetone (in a well vented area!) to get rid of any residual oils. After the acetone evaporates, you should double the clamping time for a surefire bond.

Cleaning Sanding Belts and Disks

Spray oven cleaner on your gummed up belts and disks, then scrub them with a brass brush to loosen tars and resins. After they dry, use a regular rosin cleaner to finish the job and you'll have (almost) new abrasives.

*Peter Przekop
Wilkes Barre, Pennsylvania*

Hot Glue Helper

Keeping the corners square while you're cutting picture frame parts can be difficult, especially if the stock isn't rectangular. I apply just enough hot-melt glue on each corner to hold it temporarily, but not so much that I can't break the joint to make adjustments before a final glue-up with yellow glue.

*Ben Crowe
Blackshear, Georgia*

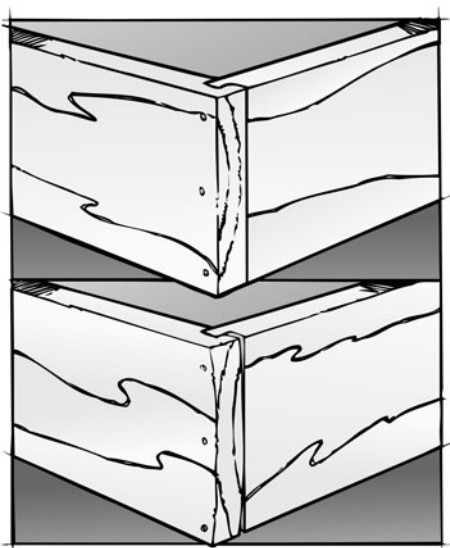

Growth Ring Joinery

For tight box or drawer corners, arrange the parts so that all the annual growth rings curve out toward the ends. Wood tends to cup in the direction opposite to the rings' curve, so if you crown the board the wrong way the rings may draw the joinery apart.

*Joe Nelson
S. CelElum, Washington*

Quick Tip

It is absolutely vital to take certain precautions when spraying finishes. Use a NIOSH approved Organic Vapor N95 respirator (95% efficient): standard dust masks offer no protection from airborne finishes. Work in a properly ventilated area, as higher concentrations of many chemicals have been linked to cancer, nerve damage and respiratory diseases. Wear eye protection, and always know where your co-workers are: even HVLP-driven low pressure sprays can penetrate skin.

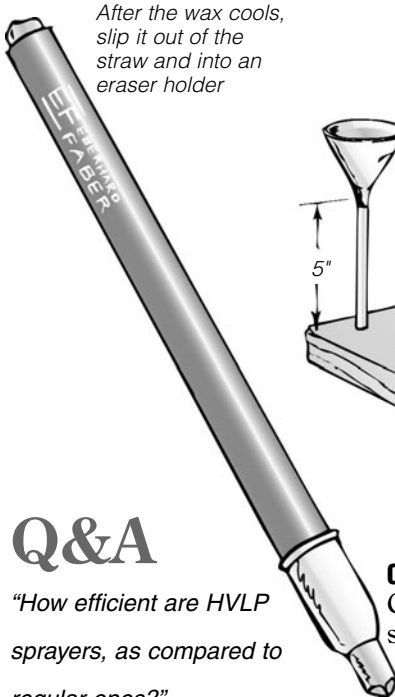

After the wax cools, slip it out of the straw and into an eraser holder

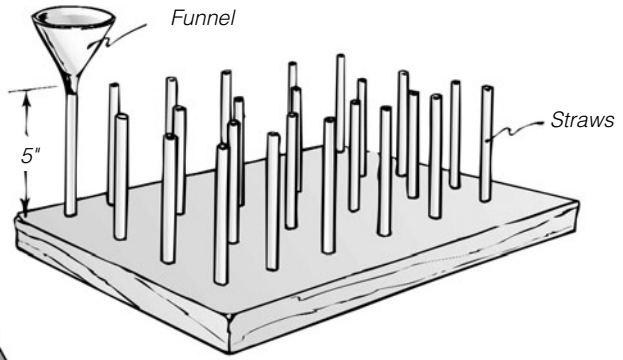

Q&A

"How efficient are HVLP sprayers, as compared to regular ones?"

A standard, inexpensive high pressure gun for your air compressor will deliver about 25% of the finish to the workpiece. HVLP (high volume low pressure) spray systems deliver between 65% and 90%, depending on the product.

Custom Wax Dispenser

Carnauba wax is easier to apply to small turnings if melted into small sticks using standard 1/4" OD plastic drinking straws for forms. The resulting 7/32" stick fits handily into eraser holders sold at office supply stores. The wax, when set, will slide right out of the straws.

*Bill Skinner
Charlotte, North Carolina*

How to Erase Burns

To eradicate router or saw burns, brush on a solvent (naptha, alcohol, mineral spirits — even water), let it soak for a minute, then sand. Mineral spirits works best, and my Dremel tool is ideal for the sanding stage. Here, diamond burrs are my tool of choice, but sandpaper can also be used.

*Stan Kasieta
Woodline, Michigan*

Quick Allen Action

I like to cut the “L” off some of my spare Allen wrenches and leave a straight end that can be chucked in a drill. It’s a great timesaver when assembling knock-down furniture.

*Roger Berg
Farmington, Wisconsin*

Flush your Dust!

A commode floor flange is a perfect fit for a 4" dust collector hose. I screwed one to a piece of 3/4" plywood and hooked up my contractor’s saw to the dust collection system. Cost was about \$5.

*Rex Roach
Opelika, Alabama*

Quick Tip

There’s nothing quite as elegant as clear strapping tape when it comes to clamping unusual shapes.

A good quality tape can be stretched to its limits and, as its memory makes it try to shrink back to its original size, it draws parts together for a perfect bond.

Mitered corners are especially suited to this technique. First, apply a short strip of tape to create a hinge, then spread the glue and close the miter. Finally, stretch the tape across it to draw it tight.

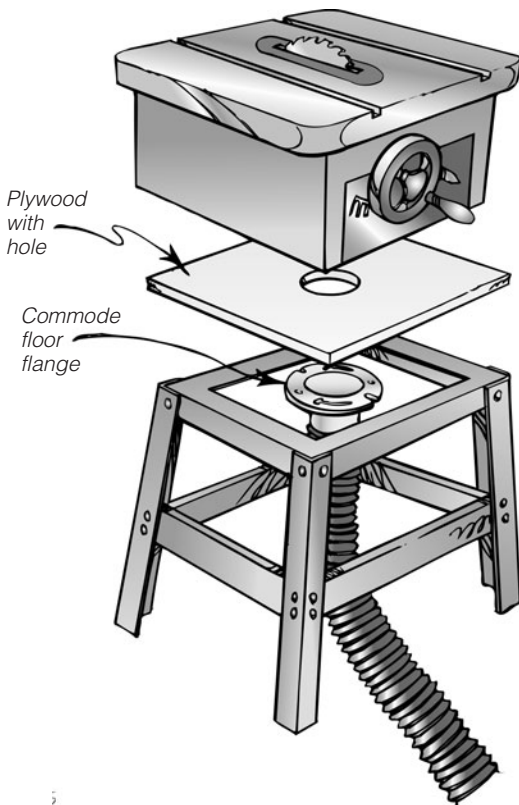

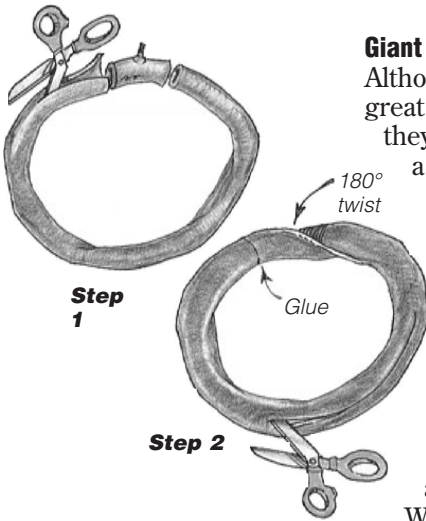

Giant Band Clamps

Although bicycle inner tubes make great band clamps, sometimes even they are not big enough. Here's a science class trick that will double their size. Cut out a couple of inches to remove the valve, then split the remainder lengthways. Now bring the ends together, and twist one a half turn (180°). Apply 2" of tire patching cement to join them and, after it dries, make another cut and slice all the way around the circumference.

When the cut returns to the starting point, you'll have one big rubber band, not two small ones, thanks to the twist you put in earlier.

*R. B. Himes
Vienna, Ohio*

Q&A

"How do I make stable butcherblock out of ordinary plain sawn boards?"

Rip a plain sawn board into strips that are 1/16" thicker than the new counter or tabletop you're making, then turn these 90° before joining their edges and re-gluing them together. This will give you a stable, quartersawn panel.

Step 3

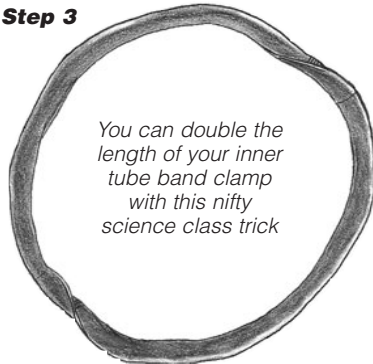

You can double the length of your inner tube band clamp with this nifty science class trick

Raising Grain

To repair a minor indent in unfinished stock, place a few drops of water in the indent, then heat it up with a clothes iron to raise the grain. Finish up by sanding it smooth.

*John Tyler
Osceola, Wisconsin*

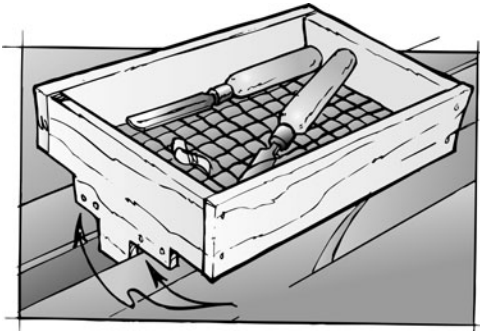

Shaving-free Lathe Tool Caddy

I wanted my woodturning lathe tools to be sharp, near and clean. So I built a simple caddy to hold them. It hugs the lathe bed securely with a dozen ring magnets embedded in its underside. I just slide this caddy close to my work, and the tools remain clean as the chips fall through the wire mesh bottom.

*Dick Dorn
Oelwein, Iowa*

Getting the Point

Finishing cabinet doors can be a real time chewer, because you generally have to wait for the first side to dry before you can tackle the second. I drove 8d finish nails through some 2" square blocks of 1x pine, then set them on the bench with the points facing up. Then I placed the doors face down on the points of the nails, finished the backs (which were facing up), and then immediately turned them over and finished the fronts and edges.

*Shay Thomas
Somerset, Wisconsin*

Quick Tip

The moisture content of wood is measured in terms of weight: the weight of the water versus the weight of the wood. On average, the ideal moisture level in stock about to be milled is around 7%: that is, the moisture in the wood should weigh 7% of what the wood weighs. Freshly cut green wood can have a moisture level as high as 200%. In that case, the moisture weighs twice what the wood alone weighs. Cross-cut a board to measure the moisture, as the ends and outer surfaces will be drier than the core.

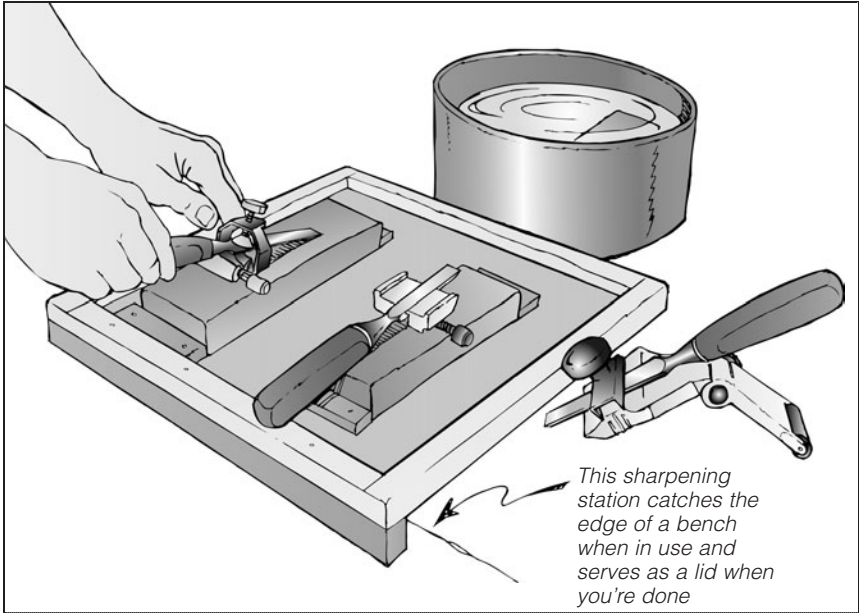

Q&A

"Why is Spanish cedar used in cigar humidors?"

This species is rich in aromatic oils that enhance the flavor of cigar smoke.

It is also easy to work, attractive and decay-resistant (which is an asset in a humid container).

Sharpening Station

You'll be more likely to sharpen chisels and plane irons when they need it if you have a sharpening station. Begin by cutting 6" off the bottom of a 5-gallon bucket and use this to keep your stones immersed in water or oil. Cut a 20" square plywood base and rout a circular groove in the bottom to turn it into a lid for the bucket. Nail strips of wood around the top so water or oil won't escape while you work. Nail a small strip at either end of each stone to hold them when they're not immersed, and a final strip under the front edge to catch the edge of your bench: this will hold the station steady as you sharpen because the lid won't slip when you push on the stones.

*Jeff Greef
Soquel, California*

Chuck Key Keeper

Drill a hole in your drill press chuck key and use a split key ring to thread it onto the power cord: now it will always be close to the tool.

*Noel Griffith
Monroe, New York*

Mitered Moldings

Moldings that have a repeating pattern on them need to be addressed at the design stage. The plan must be adjusted so the pattern matches up perfectly at the corners. One way to do this is to create a full-size drawing of the parts and test the molding's pattern on it. If resizing won't work, switch moldings.

*Rick White
Medina, Minnesota*

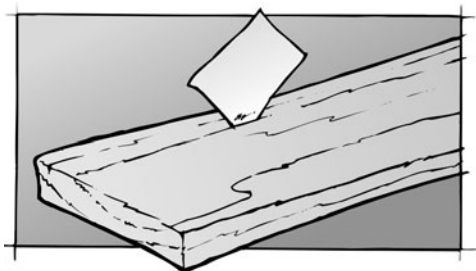

Evaluating Surface Checks

Some surface checks (short cracks) will come off in planing, while others go into the heart of the board. To see how deep they are, I simply insert the corner of a piece of paper.

*Michael Burton
Glorieta, New Mexico*

Quick Tip

Pine drawers have traditionally had hardwood runners, so the grooves in the pine drawer sides tend to wear out first. You can avoid this in new construction by milling a wide groove along the outside face of each drawer side, then gluing in a hardwood strip. After the glue dries, sand the strip flush, then mill a smaller groove in the hardwood insert for the drawer runner to ride in. This is also a great retrofit for an older, existing cabinet that has sloppy action in its pine drawers. Wax the slots with candle wax.

Q&A

"I want to assemble a cabinet with screws and dados, but my screws always seem to just miss the center of the dado. Any ideas?"

Instead of assembling the carcass, and then trying to locate the screws from the outside by measuring, just drill pilot holes out from the inside before assembly. That way, you can set the bit right in the middle of the dado each time. And with the pilot holes established, you can now countersink where the drill bit exited.

Never, Ever Let Go!

No matter how rough things get, or how probable a kickback will be, don't ever let go of the wood while your table saw blade is still spinning. You're not fast enough to get out of the way of a 50 MPH projectile. More often than not, by holding on, you will actually prevent kickback. Over the years I've trained my reflexes not to panic and jump away, so now I hold on tighter than ever. I even drive the piece forward if I can, depending on the circumstances.

*Rick Christopherson
Eagan, Minnesota*

A Dolly Extension

When I hauled trash cans and other large loads on my two-wheel dolly, they tended to tip. So I designed a small platform that enlarges the base of the dolly, providing a more stable and roomy platform. The 1/4" spacer strips are just thick enough to accommodate the dolly's blade freely.

*Ron Pavelka
Orange, California*

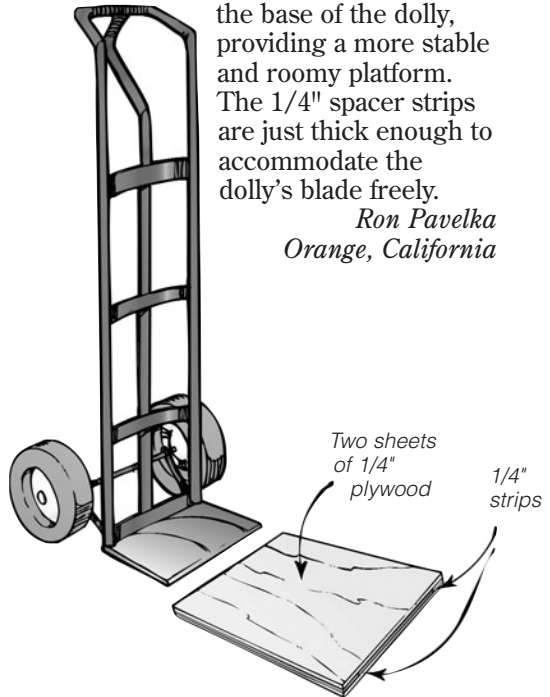

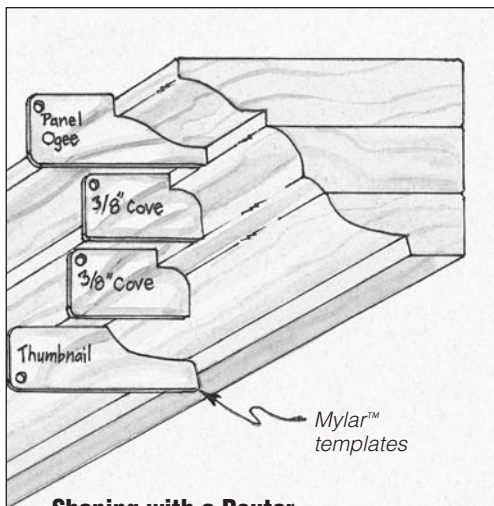

Shaping with a Router

I don't have a shaper, so I made Mylar (plastic) cutouts of all my router bits, including the bearings, and punched holes in them for a key chain. When designing a stacked shape, I just create a paper storyboard, as I can see through the Mylar. I can also determine if the guide will have a bearing surface.

*Carol J. Reed
Ramona, California*

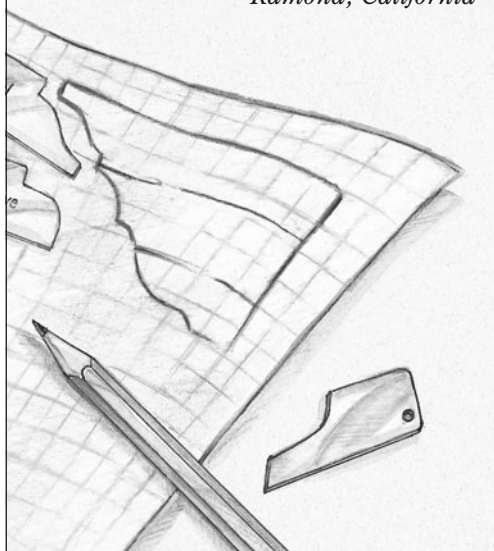

Quick Tip

The specialty bit used to create two-stage holes for pocket screws is basically a 3/8" bit with a 1/8" pilot bit stuck into its business end.

If you own one, you know just how susceptible to damage they are.

Gerald Wallin of St. Paul, Minnesota, suggests protecting the delicate pilot bit by using it to bore a 2" deep hole into a scrap block. You can then store the bit right in the scrap block. The friction fit turns the block into a nice, protective storage cap.

Q&A

“What causes kickback on my table saw?”

Kickback is caused by one or both of the following: an underpowered saw, and incorrect blade height.

If your saw is heavy and powerful enough, it will keep cutting through a twist, bind or improperly fed piece of stock. If your blade is set too low, the teeth are meeting the wood horizontally instead of vertically: in the latter case, they would force the wood down on the table, but in the former they are pushing the stock right at you.

Solving the Tan Foam Problem

The new polyurethane glues leave a tan foam around the glue line and stain on your hands. I take a rag dampened with lacquer thinner and wipe the glue line when it is foamed but still sticky. Take care not to get the solvent in the joint, where it will dissolve the glue. For my hands, I keep a jar of dishwashing soap and lacquer thinner, about an inch of each, in the shop.

*Dave Palmer
Royal Oak, Michigan*

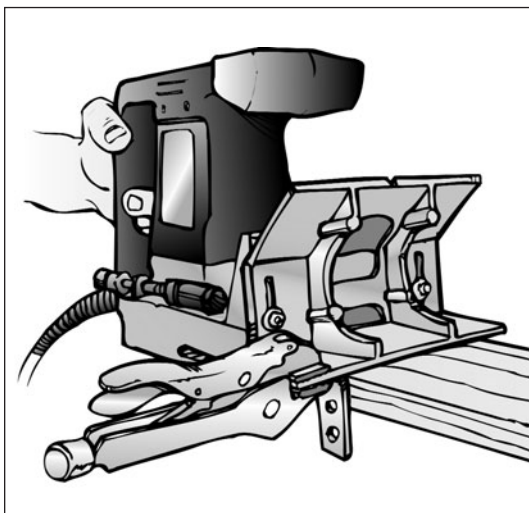

Stopping Biscuit Joiner Drift

The alignment pins on my biscuit joiner are too far apart to center a slot in the end of a narrow board. So, where a job requires numerous slots in the same position, I use vise grips and a small angle bracket to position the joiner where I need it.

*Tommy Capps
Plano, Texas*

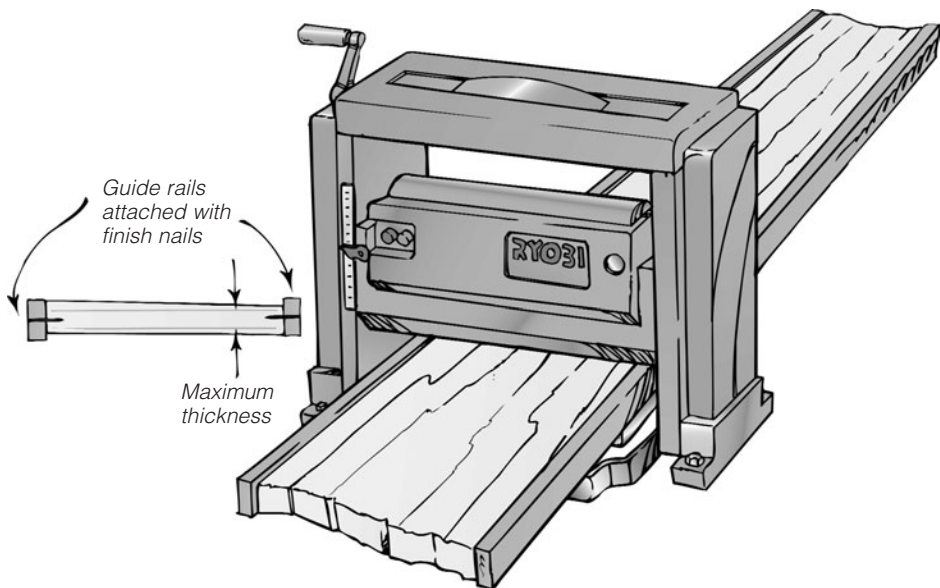

Straightening Twisted Lumber

Rough lumber with a diagonal twist can be difficult to straighten, unless you use this trick. Joint the edges of the board and set it on a flat surface. Shim the two high corners, then rip two guide rails from scrap stock: their height should be the same as the highest spot on the shimmed board, and they should be cut from straight hardwood. Finish nail these in place, keeping the nails as close to the center of the guide rails as possible, so they never come in contact with the planer knives. Then run the assembly through the planer (or a wide belt sander equipped with a coarse grit belt), alternating the sides: the top should be up on the first pass, down on the second, and so on, until the board is flat. The guide rails will keep the board perfectly aligned.

*William Woodward
Hunlock Creek, Pennsylvania*

Quick Tip

The best finish for children's toys and furniture may well be shellac, because it becomes totally nontoxic once it's dry. Shellac has even been approved by the FDA for certain applications, including drug and candy coatings.

Q&A

“Why do the pros laminate or veneer both sides of a countertop?”

They do this to keep the assembly as stable as possible, so that it will stay as flat as possible. If the top face alone were laminated, ambient humidity might enter the porous face on the underside, and that inequality is an invitation to warping. Some of the core products the pros use in cabinet shops even come from the factory with a plastic coating already applied to the underside, so the shop doesn't have to spend time laminating the underside.

Shelf Solution

When using screws or nails to attach fixed shelves in a cabinet carcass, I use a neat trick that lets me line up my shelves perfectly every time. Using a square, I draw a pencil line across each of the cabinet's sides at the center (half the thickness) of each shelf. Next, I drill holes through the sides slightly smaller than my nails will be, then set my marking gauge for half the thickness of the shelves. Starting from the ends, I work toward the middle (to avoid causing a chip at the ends) and draw the gauge several times across each end to score it. With the carcass assembled, I tap nails through the sides so the tips protrude just $1/32$ ". Then I hold the shelves up to the sides and feel the nail points fall into the grooves. As each nail finds its groove, I drive it home and set it.

*James A. Johnson
Brunswick, Ohio*

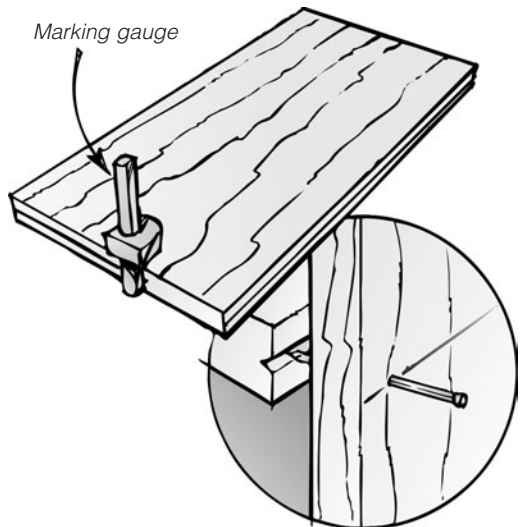

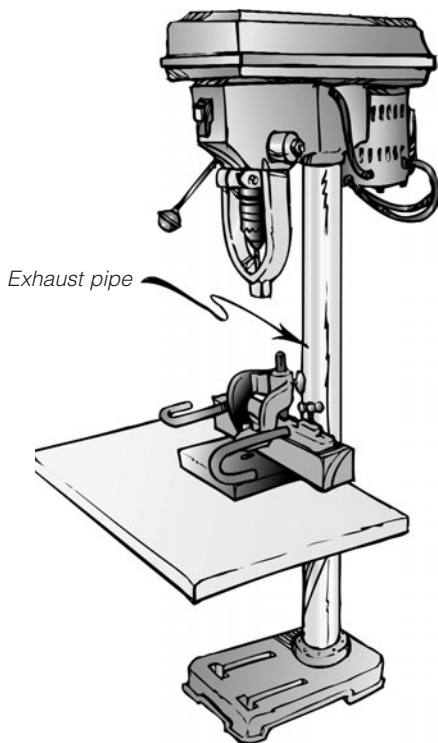

Modifying a Small Drill Press

My benchtop drill press was too short for any of the available mortising jigs. So I went to an auto parts store and, for \$6, replaced the post on my press with a straight length of exhaust pipe.

*Robert Opekun
Orange, Connecticut*

Making Milk Paint

To make one gallon of traditional interior milk paint, mix 8 lbs. of skim milk, 8 oz. of linseed oil, 12 oz. slaked (garden) lime, and 6 lbs. of calcium carbonate (whiting).

*Larry Fiscus
White Bear Lake, Minnesota*

Quick Tip

You can't mill a bullnose on the edge of a board with a bearing guided bit, at least not if you just rely on the bearing. After making the first cut, you've removed most of the bearing surface for the second cut, so it will be offset (the bit will remove more stock on the second cut than the first). The answer is to make both cuts using the same bearing-guided bit, but you have to rely on your router table's fence, instead of the bearing, to guide the cuts.

Q&A

“How do I apply a water-based aniline dye?”

After sanding the project to 120 grit, raise the grain with a damp sponge and sand with 220 grit paper. Add a drop of dish soap to the dye solution to help break the surface adhesion and let it penetrate properly. Apply the dye with a foam brush and wipe it off immediately with paper towels. Wear rubber gloves, as sweat can leave marks on the stain.

Budget Bushings

When a number of holes have to be drilled, a jig with a drill bushing comes in very handy. If you're ever caught without the bushing, try grabbing an appropriately sized T-nut instead. I install one in the jig and drill it out for the correct size drill. This trick won't hold up in daily use, but it sure works well for ten or twenty holes.

*Jack Zabel
Cedar Falls, Iowa*

Pizza Pedestals

Save the plastic spacers from delivered pizza and use them to support projects during finishing.

*Randy Wells
Bethalto, Illinois*

Stretch your Pipe Clamps

On those few occasions when you need an extra-long clamp, don't buy long pipes that will spend the rest of their lives in a dark corner. Just invest in a couple of pipe couplings and join two or more of your existing short lengths together.

*Michael Burton
Ogden, Utah*

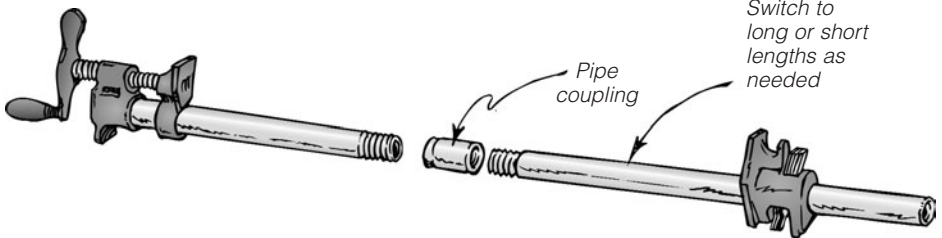

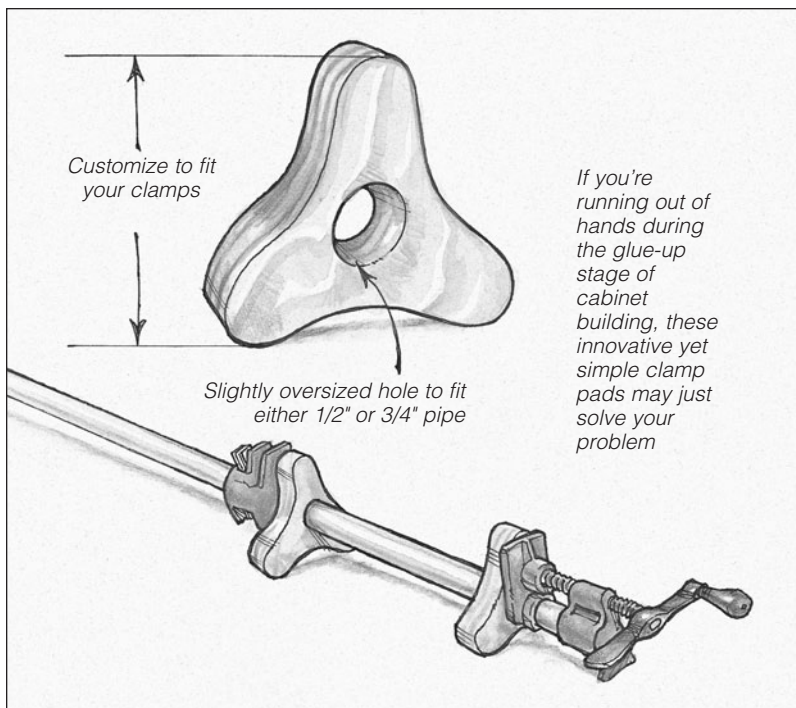

If you're running out of hands during the glue-up stage of cabinet building, these innovative yet simple clamp pads may just solve your problem

Innovative Clamp Pads

Positioning a pad between the jaw of a bar clamp and the assembly you're building can be tricky. Trying to keep the clamps in position — especially when you're at the other end of a large cabinet — can be downright frustrating. My three-spoke pads solve both problems at once. Two of the three spokes become the stand's legs (they even allow for uneven surfaces), while the third spoke automatically centers itself as a hands-free pad between the metal of the clamp jaw and the workpiece being glued up.

*R. B. Himes
Vienna, Ohio*

Quick Tip

For worktops on outdoor projects like grills, tables and barbecue carts, some solid surface materials like Corian® work extremely well. You can pick up a sink cutout at a cabinet shop for a minor charge, or even for free. Although some products aren't certified for outdoor use, they all seem to hold up very well.

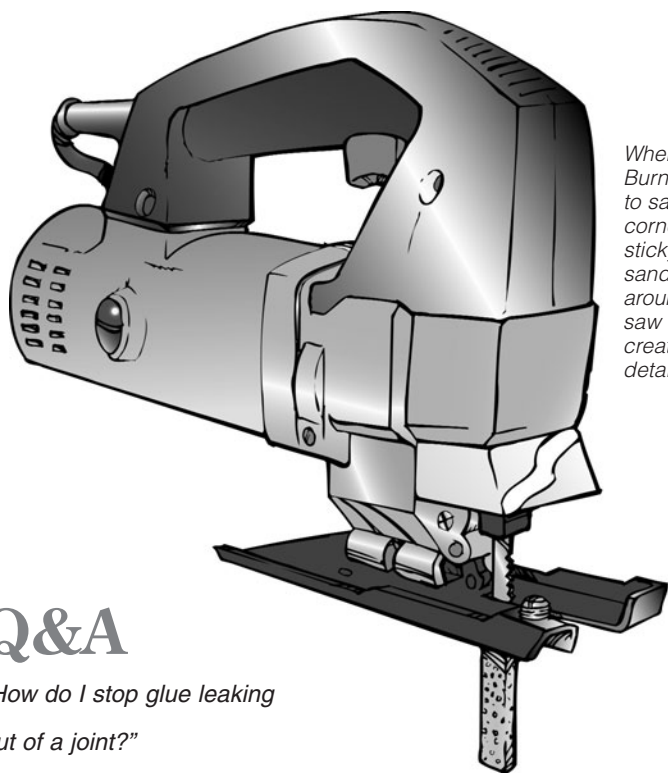

When Ray Burnthorn needs to sand tight corners, he wraps sticky-backed sandpaper around his saber saw blade and creates an instant detail sander



Q&A

“How do I stop glue leaking out of a joint?”

The easiest way to control glue is to use a sharp utility knife or a rotary cutter in a multi-tool (like a Dremel®) to score a small V-shaped channel just out of sight on the hidden parts of the joint. The groove should be about 1/8" in from the edge. Glue traveling toward the edge should settle in this groove.

Jigsander

Here's a terrific trick that I use when I make lawn ornaments. To clean up the intricate cuts, I wrap a piece of self-adhesive sandpaper around the jigsaw blade. You'll have to open the cooling blocks for this to work, and the stiffest blade I've found is a Porter Cable 12361.

*Ray Burnthorn
Manteca, California*

Sticky Sticks

If you're using plastic packing tape as a clamp, place a popsicle stick on either side of the glue joint to raise the tape out of the glue.

*John Tancabel
St. Paul, Minnesota*

Thinning your Aging Glue

Most yellow aliphatic resin glues (like the Titebond® brand that my employer makes) have a shelf life of about two years, and weatherproof glues can often last twice that long. If you're not sure how long your glue has been on the shelf, there's a quick way to test its usability. If it rolls up in a little ball or is rubbery, it's time to go shopping. Yellow glue should survive at least five freeze/thaw cycles: it will work just as well, but its consistency may change. Thick glue can be stirred, or you can even add up to 5% water without affecting the bonding strength.

*Dale Zimmerman
Columbus, Ohio*

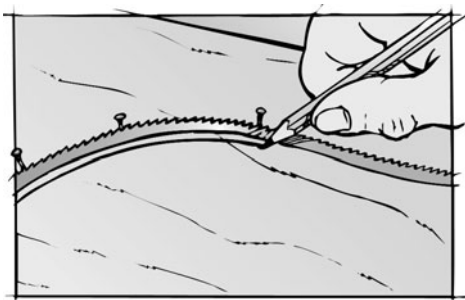

Drawing a Smooth Curve

An old band saw blade works wonderfully for drawing smooth curves. Drive nails at key spots along the waste side to guide it along.

*Michael Burton
Ogden, Utah*

Quick Tip

Because solid surface materials like Corian® are really just plastic, they can generally be worked with woodworking tools. They do, however, require that you equip your tools with carbide blades and bits as they are usually about three times as dense as most hardwoods. Take your time: when routing a decorative edge, make several passes. To achieve a matte finish, start with 180 grit and work down to 400 grit, then buff with a green Scotchbrite® pad.

Q&A

*“How do I make
dentil molding?”*

Dentil molding is a classic piece of trim that looks like a series of teeth and gaps (hence the name). The easiest way to mill it is to clamp a straightedge across a board and rout a dado, then screw a guide that has the same dimensions as the dado to the bottom of your router (you may want to attach a plywood base first). Then you can just run the guide in the groove you cut to mill the next groove, and so on. After all the grooves (or gaps) are cut, rip the board into strips that are whatever width you want your molding to be.

Large Cabinet, Small Shop

Your cabinet is all assembled and you're doing the final sanding. So, how do you protect the just-finished side when you lay it down to sand the opposite side? I prefer to use ceiling tiles — the type that don't have a hard surface — and place them on the floor or the bench.

*Tom Palubecki
Milwaukee, Wisconsin*

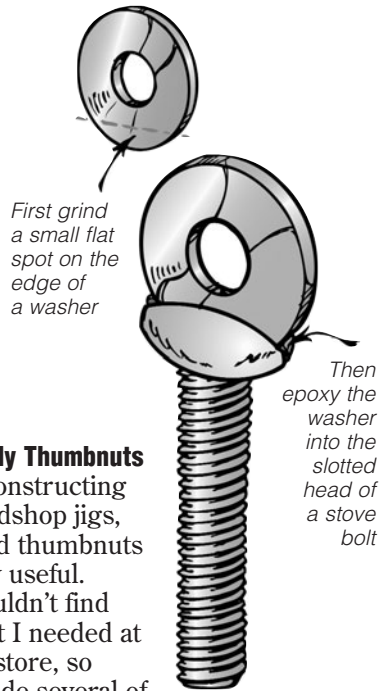

*First grind
a small flat
spot on the
edge of
a washer*

*Then
epoxy the
washer
into the
slotted
head of
a stove
bolt*

Handy Thumbnuts

In constructing woodshop jigs, I find thumbnuts very useful. I couldn't find what I needed at the store, so I made several of the versions shown here in assorted sizes. Just grind a small flat spot on the bottom of a washer, then epoxy it into the screwdriver slot in the top of a stove bolt.

*Robert Guyan
Portland, Oregon*

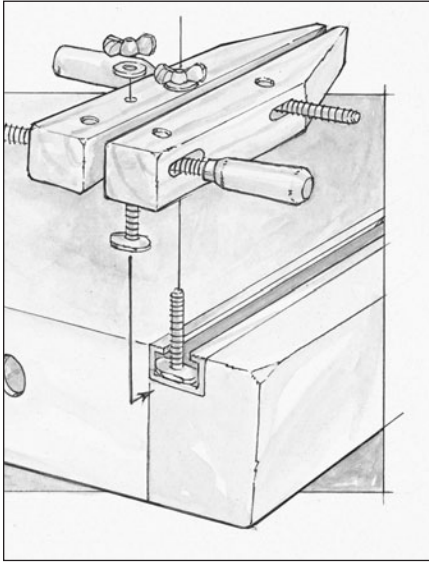

Instant Workbench Vise

Most workbenches have two vises that allow you to work at either one side or an end. Mine only had one vise at the end, so I decided to use an embedded T-track on the bench to hold a couple of 10" screw clamps. All I had to do was drill a hole in each clamp and insert a T-bolt. A wingnut makes adjusting easy. Sliding one clamp in from each end gives me an instant vise.

*Joe Cormier
Peabody, Massachusetts*

Clean Magnets

When picking up iron or steel filings with a magnet, wrap the magnet in a paper cloth and you'll be able to discard the refuse more easily.

*Harold Keenan
Danbury, Connecticut*

Quick Tip

Shellac flakes are mixed with denatured alcohol in various ratios, or cuts.

One pound of shellac mixed with one gallon of alcohol produces what is called a "one-pound cut."

A three-pound cut would still only have one gallon of alcohol, but three pounds of flakes. The lower the cut, the thinner the mix. That means more coats, but a smoother application. It's all a matter of personal preference. Either way, make sure you buy fresh flakes, as older stock will give you some serious application headaches.

Q&A

“How do I stop my large square from slipping when I use it as a straightedge to draw layout lines?”

This is a common problem, and the best solution we’ve seen is compliments of Michael Burton of Glorieta, New Mexico. Michael drilled several holes in his square, each the exact size of a metal push pin’s shank (the kind you find on bulletin boards). The sharp point leaves such a small hole that it simply isn’t an issue. Another suggestion is to apply a roll of 220 grit self-adhesive sandpaper to the bottom of the square.

Harold Hubbard’s drill press fence pivots on one end so he only has to tighten one clamp to set it.

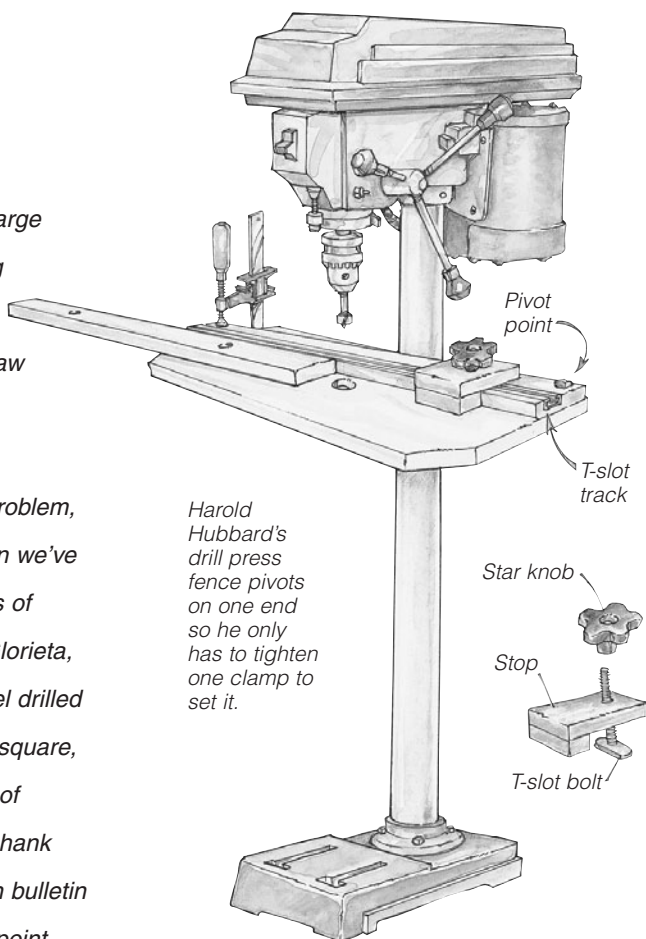

T-slot for Instant Stops

I use a pivot fence on my drill press as it’s easier to adjust than the ones that rely on C-clamps. For stops, I used T-slot hardware: bolt heads ride in the track which is incorporated in the fence, and my stops attach to the bolts via star knobs. They are infinitely adjustable and easily removed.

*Harold A. Hubbard
Berkeley, California*

Humidity Stick

I build and repair fine furniture for a living, and tracking humidity levels in my shop is critical to my success. A few years ago, I edge-glued several short lengths of 1" x 2" red oak together, then attached a strip of 3/4" x 2" hard maple to one end of the block. Ever since then, once a week I mark the other end's location on the maple and date it. I now have a track record of the humidity in my shop that tells me what times of the year the highs and lows occur, and an instant reference that can be checked on any given day.

*Tom Caspar
Minneapolis, Minnesota*

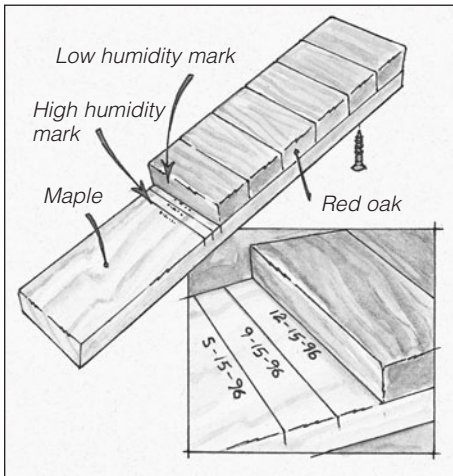

Substitute Work Supports

I was cutting a sheet of plywood and needed extra support when I noticed the family ironing board hanging in the corner. I figured, why not? It's smooth, inexpensive and everyone owns one. I got a great laugh from a fellow woodworker when I told him.

*Joseph Roberge
Brown Mills, New Jersey*

Quick Tip

When you're designing the joints in a piece of furniture or casework, think not only how they will look and work, but also how they will be machined. For example, if you install a 3/8" dado head in the table saw and set the height at 3/8", you can cut both parts of a rabbet and dado joint without ever changing your setup. If you place 3/8" dowel joints and 3/8" shelf supports in the same relative locations in a cabinet, you can use a single drill press setup for both tasks. And if you make stiles, rails and trim pieces the same width, you can rip and joint them all at the same time.

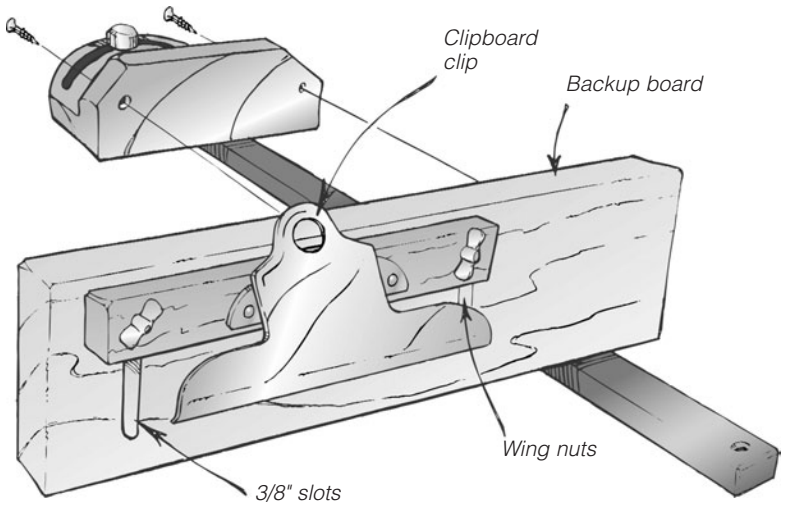

Q&A

"Should I buy carbide-tipped or just high speed steel (HSS) router bits?"

The experts disagree on this issue. While most automatically answer carbide because it outlasts steel by 15 to 25 times, some pros like steel because they're a lot less expensive, they can be sharpened in the shop, and they can be ground to alter their shapes.

Small Stock Miter Gauge Clamp

Trying to hold small pieces of stock against a miter gauge can be tricky, but the stout spring and wide jaws of a clipboard clip can help. Attach the clip to a piece of scrap, which in turn is screwed to the miter gauge. You can also rout grooves in the scrap and use wing nuts to attach the clip: this lets you raise or lower the unit as needed. A scrap backup block reduces tearout.

*R. B. Himes
Vienna, Ohio*

Veneer Quick Dry

If you moisten veneer with water and glycerin to flatten it, here's a great way to dry it. Simply place it between sheets of corrugated packing material. The corrugations permit air movement and the sheet and material will withstand a terrific amount of weight. A fan can be used to speed drying.

*Michael Burton
Ogden, Utah*

Drum Sander Jig

When using a drum sander in the drill press, the sandpaper at the bottom always wears out first. To remedy this, I made a sanding box out of 3/4" particleboard that I clamp to the drill press table. Cut a 3 1/2" diameter hole in the top of the box for a 3" drum, and a 1 1/2" hole in the bottom for a 1" drum. Make the sides tall enough to fit the drums. You can now raise the table or lower the chuck to use all the sanding surface.

*Martha Dawson
Squaw Valley, California*

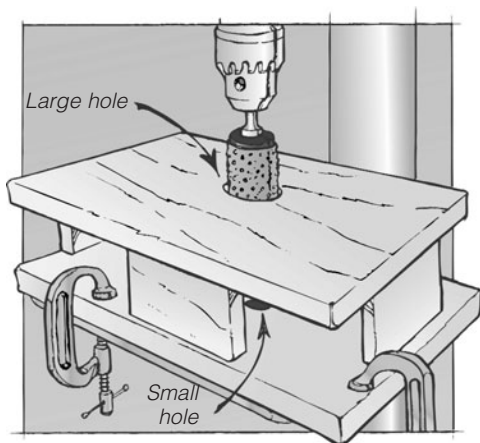

Getting Out the Glue

I always keep a couple of bottles of wood glue handy in my shop, but when I don't use them regularly, the tips get clogged. Now I use a 2-quart milk container with the top cut off to keep some water handy. Whenever I use a glue bottle, I replace the cap with a fresh one and submerge the used cap in the water.

*Howard E. Moody
Upper Jay, New York*

Quick Tip

If, like most of us, your budget will only allow you to buy either a shaper or a large router, the experts all say to go the latter route. Routers are more versatile and less expensive, plus they can do a lot of things a shaper can't — like mortising and using a dovetail jig. A shaper is definitely the right tool in large production jobs, but a big router can do pretty much everything a shaper can, only slower. While an industrial shaper with a 1 1/4" spindle can easily handle 4" stock in one pass, even a 3HP router will need to make several passes to do the same job.

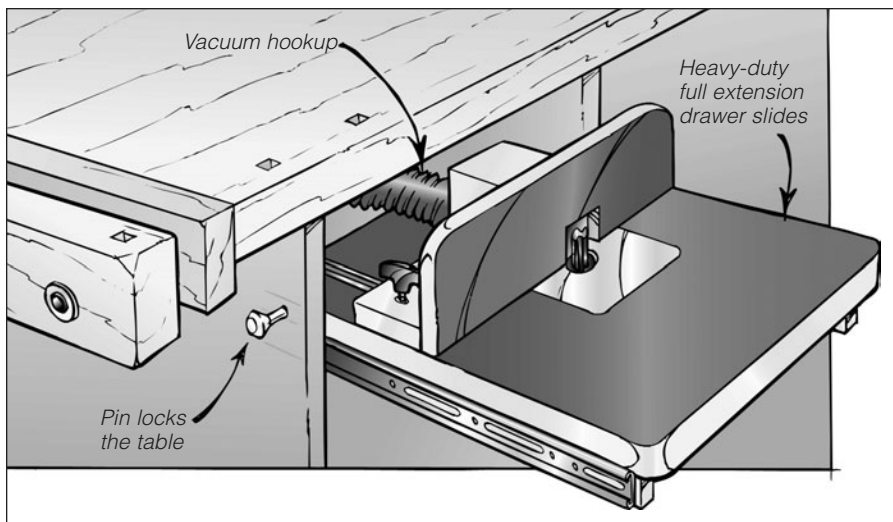

Q&A

“Do I have to throw away my paint brushes when they get stiff?”

Absolutely not. One of the best ways to restore brushes when the finish has hardened is to soak them in stripper for a few minutes. Work the stripper up along the bristles until all the finish is loosened. Then thoroughly wash the brush, because stripper will loosen the bristles if it's left alone.

Pull-out Router Table

In a small shop, my router table may create a little room. I used full extension, heavy-duty slides and added a locking pin to keep the table from moving during operation. When not in use, it slips right out of sight.

*Thomas Pratley
Oxnard, California*

Finger Protectors

When I sand small items, I protect my fingers with those flexible rubber tips that office supply stores sell to people who count money. They're cheap (about \$2 a dozen), and they give you a good grip on small workpieces.

*R. B. Himes
Vienna, Ohio*

Inexpensive Quartersawn Stock

Need a small piece of quartersawn stock? Plain sawn boards all have quartersawn grain along their edges!

*John Tancabel
St. Paul, Minnesota*

Clay is handy in the Shop

I often need to paint small items of hardware (nail heads, screw eyes etc.) for use on one of my wood-working projects. I have found that a 1 lb. box of modeling clay is very handy for these jobs. The clay won't harden, yet is firm enough to hold assorted small parts for painting. It also works well for glue-ups.

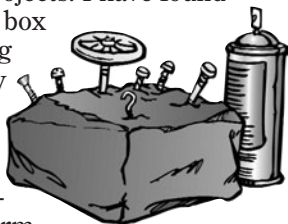

*Howard Moody
Upper Jay, New York*

Vibration Dampers

The heels from a tired pair of running sneakers generally have enough rubber-type material to make excellent vibration dampers for shop tools and tables. They can be custom cut with a bread knife. Use a Forstner bit to recess a bolt head and washer for mounting.

*Joseph Fetchko
Ocean City, Maryland*

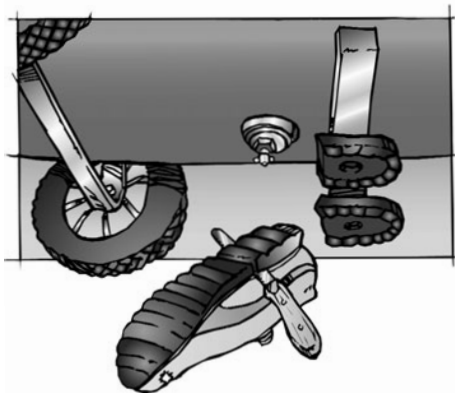

Quick Tip

Certain wood species are naturally more resistant to exposure than others, so using one of them in outdoor projects is the way to go. Certified farm-raised teak is perhaps the most resilient, but it tends to be oily and often doesn't glue very well. White oak (not the common red variety) is far less expensive and does well outdoors, as do cedar, redwood, Spanish cedar and Honduras mahogany. The key is in the finish you apply: research is advised.

Q&A

"How do I get rid of snipe?"

Snipe is that annoying little concave area that a jointer or thickness planer leaves on the last couple of inches of a board. It is caused by an outfeed table that is set lower than the knives, or else the workpiece is just too short. Dealing with it involves adjusting the outfeed table, planing longer boards, or buying one of a new breed of planers that are marketed as being "snipe-free." Traditionally, woodworkers have just run boards that are 6" or 8" too long, then they've trimmed the snipe from the ends on the miter saw. It's not thrifty, but it works.

Hinged Board Jacks

Board jacks are used to support long boards clamped in a bench vise. I cut two 12" long pieces of 5/4 oak and attached one to each front leg of my workbench with a pair of butt hinges. I used a straightedge to keep the jacks at the same level as the bench vise. The hinges allow me to swing the jacks out of the way, alongside the legs but tucked under the overhangs at the ends of the bench, when I don't need them.

*Kevin Hemmingsen
Wabasha, Minnesota*

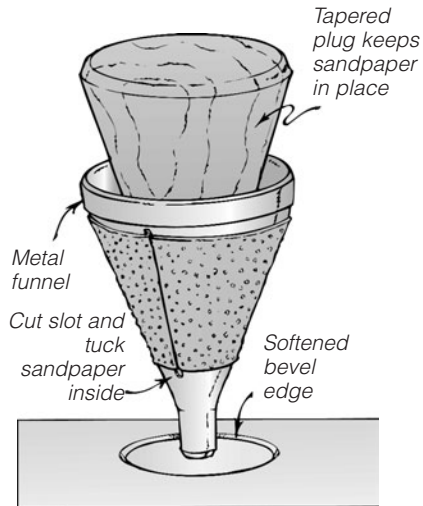

Hole Beveling Sanding Block

Putting a beveled edge on a hole is easy with a metal funnel. Cut a slit in the side, then wrap a sheet of sandpaper around the funnel with an inch or so of each end inside the slot. A tapered plug secures it.

*R. B. Himes
Vienna, Ohio*

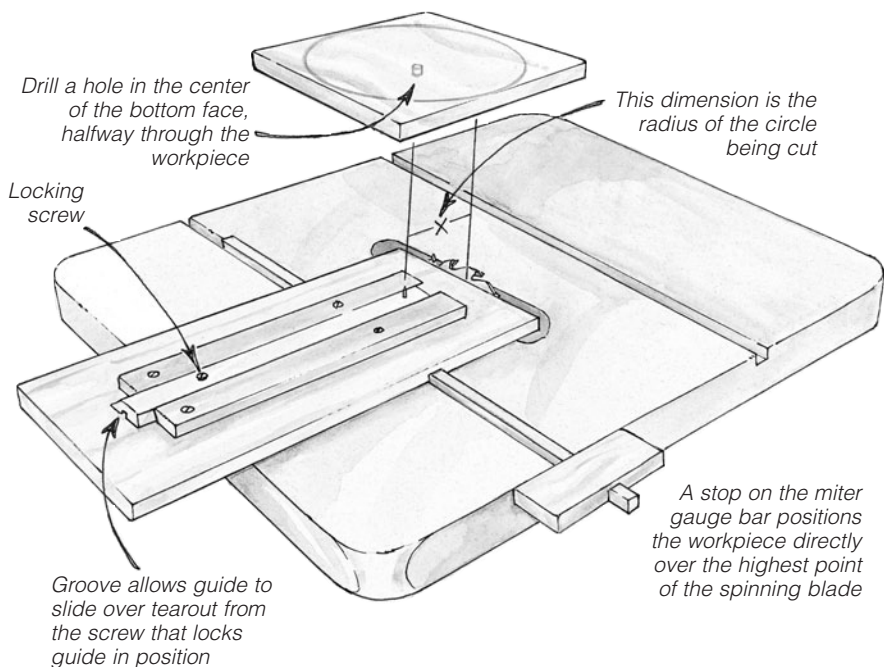

Cut Circles on the Table Saw

The base of this jig is just a platform with a bar that runs in the miter gauge slot. A guide slides across the top, locking into position with the turn of a screw to allow you to cut any radius. One end of the guide houses an upturned nail. To use the jig, drill a small pilot hole halfway through the center of the workpiece. Set the radius (the distance between the center of the pivot and the near edge of the blade), then drop the piece upside down on the nail. SLOWLY raise the blade 1/16" per full revolution of the workpiece. Rotate the piece slowly, too, or the wood will burn and may become airborne. For circles under 12", use a push stick. Always keep downward pressure on the wood above the nail.

*Michael Trotter
Giebelstadt, Germany*

Quick Tip

You can tell if the infeed and outfeed tables of a jointer are parallel by running some test boards and holding the jointed edges together. If the centers touch but there are gaps at the ends, one or both tables are low near the cutterhead. You only need to adjust the infeed table.

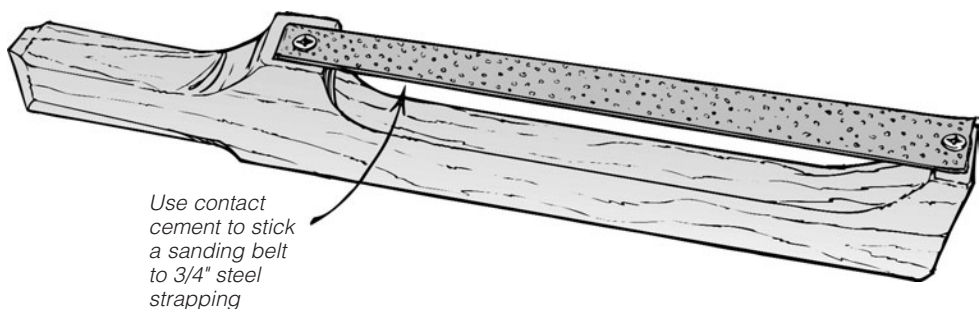

Use contact cement to stick a sanding belt to 3/4" steel strapping

Q&A

"I get very nervous routing small parts, especially those that bring my hands within an inch or two of the bit. Any ideas?"

Hot-melt glue a large handle to a small part before you approach the router bit. Or you could glue a piece of paper to the workpiece with regular yellow glue, and glue a handle to the paper: this makes it easy to take them apart when you're done routing. You'll only have to do minor sanding.

Stiffen that Sanding Cloth

A sanding bow is great for curved surfaces, but sometimes it just isn't stiff enough. I glue the cloth to a strip of 3/4" steel strapping for greater control on intricate jobs.

*Michael Burton
Glorieta, New Mexico*

Masking Tape Eases Blade Changes

Here's an extremely basic suggestion for changing band saw blades, but one that is often overlooked. Just use a few short strips of masking tape to hold your band saw blade on the first wheel, while you thread it onto the second one.

*Clifford Schwieger
Minneapolis, Minnesota*

Reduce Scroll Saw Chipping

I use clear plastic laminate from an office supply store to reduce tearout when I scroll saw very thin stock. I just copy the pattern onto the laminate in a copy machine, then stick it to the wood.

*Jack Williams
St. Joseph, Illinois*

Winning the Air Hose Battle

For a long time I battled my 100-foot air hose every time I needed just a little more than my yellow coil hose could reach. But now I just pull as much hose as I need out of a 5-gallon pail. I drilled a 1" hole in the bottom for the male end to stick out and a 1" hole in the cover to push the hose in. Thread the male end through the cap and then through the bottom of the pail. Put the cap on the bucket, and push the rest of the hose in. Now you're all set to plug the male end of the hose into your air compressor and pull out as much hose as you need. The rest stays out of sight, and you don't have to buy an expensive hose coil.

*Jim Galewski
Winona, Minnesota*



Quick Tip

Every woodworker should get the chance to use a sharp, well-tuned hand plane. Begin tuning yours by removing the blade and flattening the bottom on a lapping plate. This is a piece of thick glass (3/8" or 1/2") with sandpaper glued to it. Use the lapping plate to flatten the back of the cutting iron, too, before you sharpen the front of it. Use a honing guide to re-establish the 30° bevel on the iron, then grind a second (27°) bevel with an aluminum oxide wheel on the grinder. After assembling the plane, lubricate the sole often with paraffin wax.

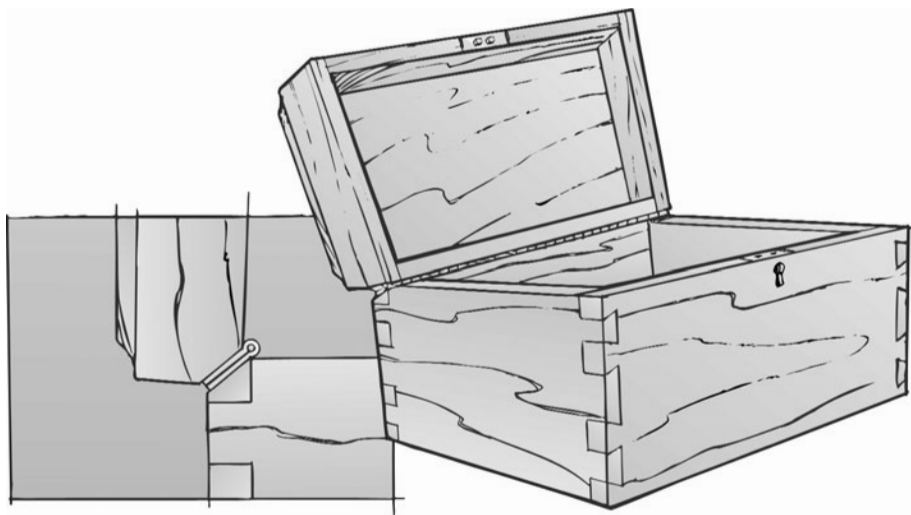

Q&A

“What temperature should my shop be for finishing?”

According to finishing specialist Jerry TerHark, there are three rules for finishing: the room should be 72°. The finish should be 72°. And the wood should be 72°. Kidding aside, the main thing is to have these three components the same temperature, close to 72°.

A More Efficient Lid Support

Every time I built a box, installing the lid support made me cringe. Not only did the support add cost to the project, but it usually interfered with whatever I wanted to put inside the box. I have discovered an alternative to the lid support, especially on small boxes with lightweight lids. Cutting the lid and the box at an angle before setting the hinge makes for a self-supporting lid. Cutting 45° angles will keep the lid perpendicular to the box, but this is usually a little more than necessary and puts undue strain on the hinge and screws. In most cases, I find that 40° angles are sufficient.

*Michael Burton
Glorieta, New Mexico*

Thin that Glue

Cut your carpenter's glue on veneer projects with a little water, to improve its viscosity and drying time.

*A. M. Benson
Houston, Texas*

Removeable Tray Adds Versatility

Last year I built a workbench from plans in your magazine. I included T-slot tracks that allow different stops, guides and jigs to be attached to the bench: I'm currently using your clamp support jig for glue-ups, and the T-square jig for layouts and dado routing.

This year, I added a tool tray to my workbench. It runs the full length of the back of the bench, and is very handy on some hand tool intensive projects. But it tends to get in the way with bigger casework projects. Because of that, my design uses the T-slot system to make removing the tray a snap.

*Joe Cormier
Peabody, Massachusetts*

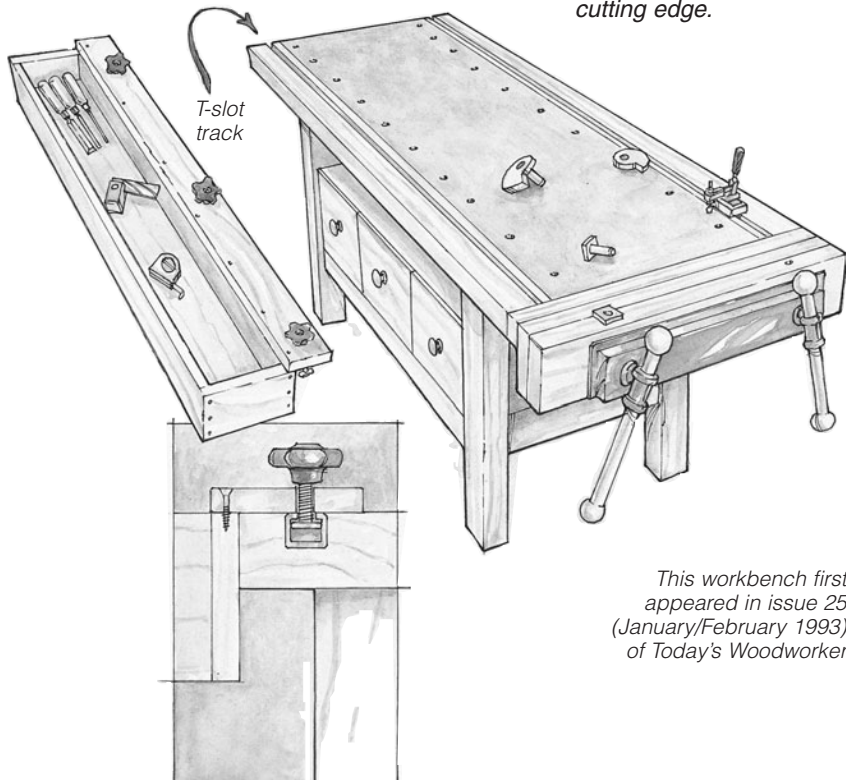

Quick Tip

Setting the iron on a hand plane can be a delicate process. The plane's mouth must be open enough to admit a plane shaving, but the smaller the opening the less tearout there will be. So a plane set for curly woods should have a very small opening with the cap iron barely set back from the cutting edge.

This workbench first appeared in issue 25 (January/February 1993) of Today's Woodworker

Q&A

“For some reason the section of veneer I think will look fantastic always comes up short in the final analysis. How do I select a better piece?”

Nature’s paintbrush has created some truly astounding patterns in wood. When looking at a whole sheet of veneer, it’s difficult to choose the exact piece of the pattern best suited to your project.

Here’s an old pro’s trick to help you out: cut a hole the size of your substrate in a large piece of paper and move this around like a picture frame to select the most appealing pattern.

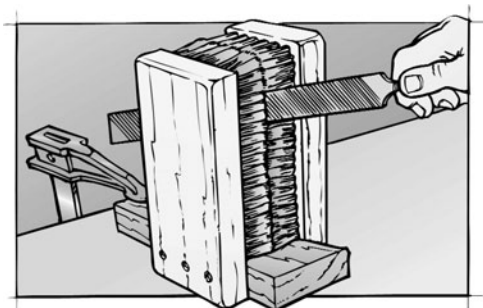

File and Rasp Cleaner

Sometimes I feel I spend more time cleaning out the wood particles that clog my rasps and files than I do shaping the wood. To remedy this, I took two inexpensive scrubbing brushes and trimmed off all the bristles 1" from one end of each. I screwed both brushes face to face on a 3/4" thick piece of pine that was just wide enough so the ends of the bristles met. Now all I have to do is saw the files and rasps down the middle, or move them in a figure eight for stubborn debris.

*R. B. Himes
Vienna, Ohio*

Loosen Up a Little

Never leave a tool with wooden threads screwed tight when it’s not in use. Leave the threads loose to prevent damage from changes in humidity and resultant wood movement. For similar reasons, router bits should always be removed from the collet after you have finished working with them. If you don’t, you risk having the bit rust to the collet or get locked in by resins.

*Hugh Foster
Manitowoc, Wisconsin*

Quick Tip

If you're asked to build a cigar humidor, you should know that cigars are hygroscopic: they dry out when the surrounding humidity level falls and absorb too much moisture when it rises. A dry cigar burns too quickly, and the smoke is hot and acrid. A moist cigar is hard to draw on, with heavy smoke and a tart aroma.

Knee-activated Safety Switch

This simple addition to my table saw required less than \$6 in materials and took about 30 minutes to complete. It allows me to safely hit the OFF switch with my knee or shin without having to grope blindly while my hands are still holding the stock. A light tap anywhere on the 1/2" PVC frame does the trick, and the large open frame doesn't obstruct access to the ON switch or the blade height crank. My saw is a Grizzly Cabinetmaker; however, most any make can be accommodated with slight alterations to the basic scheme.

*J. D. Carlson
Cary, North Carolina*

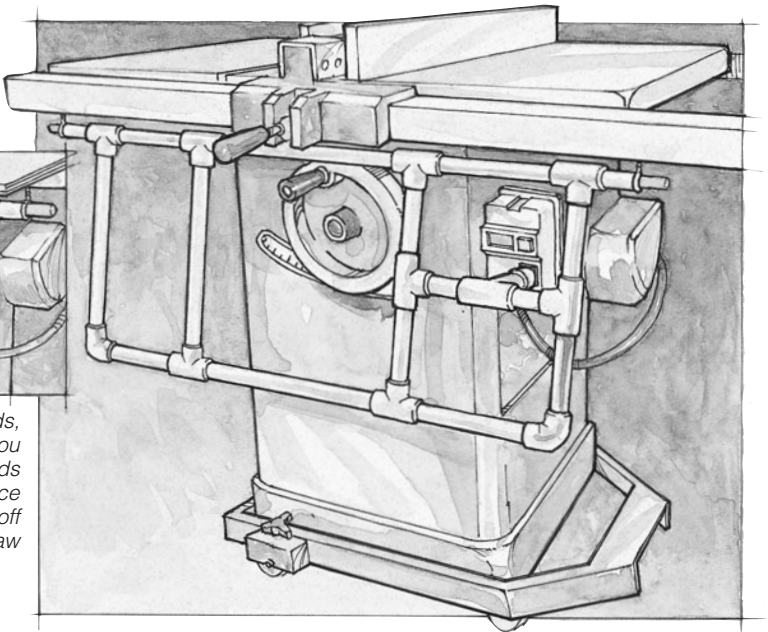

If the wood binds, this jig allows you to keep your hands on the workpiece while shutting off the saw

Q&A

"What kind of casters will let me move machines around the shop?"

Generally, the ideal setup is to have two fixed casters at one end of the machine, and two swivel casters at the other. That way, you can steer in much the same fashion as an automobile. All four should be locking, so the machine is stable in use. They should also be sized correctly: casters are rated as to the weight they can carry, so four 30 lb. casters can, in combination, tote a total of 120 lbs. Err on the side of caution and use heavier casters than you really need.

Improved Router Pad

I improved my pad for routing and sanding small pieces by stapling it tightly over a 1/4" plywood base. Now it is always ready to use, stays wrinkle free and, more importantly, doesn't have a tendency to oscillate or slide when I sand small pieces with my oscillating sander. The portion of the pad stapled under the perimeter of the plywood base keeps the pad stable on my workbench.

*Dick Dorn
Oelwein, Iowa*

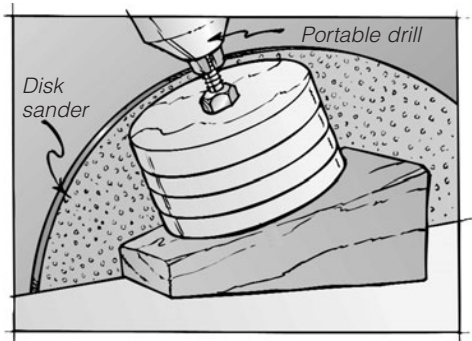

Making Perfectly Round Wheels

If you need a pair of wheels (or maybe even four), scribe circles on your stock and cut the wheels out on the band saw, staying just outside the lines. Drill a 1/4" hole at the center of each wheel, then slide the wheels onto a 1/4" threaded rod and tighten with nuts. Chuck the rod into your portable drill, clamp a wooden guide block onto the table of your disk sander and, with the drill in reverse, sand the wheels to their final size.

*L. K. Bolay
Oak Harbor, Ohio*

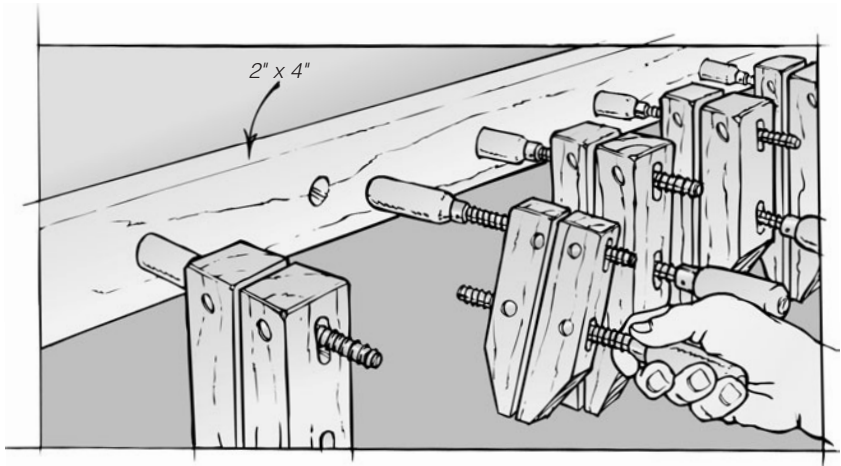

Storing Hand Screws

I've seen a variety of methods used to store hand screws (or parallel clamps). Most require returning the clamp to a holding position or some other setting. I drilled a 2" x 4" on edge with holes the size of the clamps' handles, and mounted it on the wall. When I'm done using them, I simply insert the clamp, rear handle first, into one of the holes. This way, the clamps can be stored in any open position and the holes can be just close enough for clearance, minimizing lost space.

*John Kindseth
Lodi, California*

Magnetic Vise Pads

Soft plastic business cards, intended as a refrigerator adornment, are given away by all kinds of businesses including realtors and insurance agents. They make excellent pads when used with steel clamps.

*Joseph A. Fetchko
Ocean City, Maryland*

Quick Tip

The safest way to resaw a board into two thinner boards is to run the board through the table saw on both edges to remove most of the waste, then finish up by separating the two halves on the band saw. A quick run through the thickness planer (or a short dance with a belt sander) and your boards are thin, flat and ready to go.

Q&A

“Why do hardwood plugs always show up so dark?”

The average hardwood plug is little more than a short length of dowel, so the part that is visible, after you’ve capped a screw and sanded it flush, is all end grain. This is a lot more porous than face grain, so it absorbs more stain and/or finish, hence its darker color. You can buy or make (with a plug cutter on the drill press) face grain plugs that blend in a little better. But sometimes if you can’t totally hide something, it’s better to show it off: plugs of a contrasting species may just be the way to go.

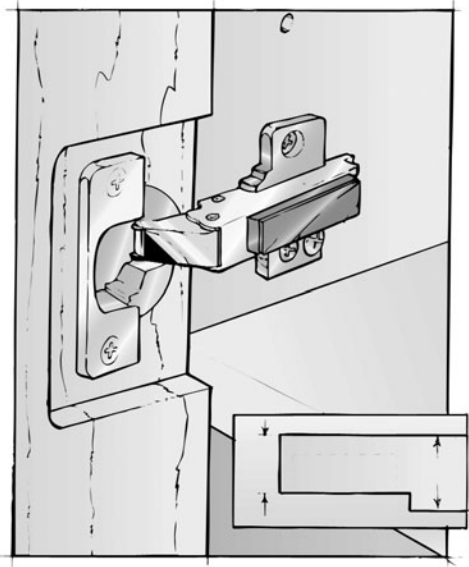

Retrofitting 1" Doors

I was retrofitting an old cabinet with cup hinges instead of the broken butt hinges that were on there, and ran into a problem when I discovered that the old doors were 1" thick. My standard hinges were for 3/4" thick doors. Instead of buying expensive replacement hinges designed for 1" doors, I just routed out an area a little larger than the cup and screw flange, reducing that small area to 3/4" thickness. I have found that this method works well on most inset doors: it presents a nice, clean look and will work for just about any door thickness.

*Dennis DiVito
Buena Vista, Virginia*

Save Your Glue

I use dish soap bottles for glue. If you won't be using them for a while, you can squeeze the air out.

*Michael Vanderhorn
Bayonne, New Jersey*

New Life for Cracked Blades

I have had several of my wider band saw blades — those over 1/4" in width — develop slight cracks, and have found that I can save them if the crack doesn't extend more than 1/6 of the way across the blade. I drill a very small hole with a #60 drill bit right at the bottom of the crack and the blade is ready to go back to work again.

*Howard E. Moody
Upper Jay, New York*

New Use for Post-it™ Notes

Marking the spot to drill for hardware on a freshly finished piece can be scary. Fresh finishes mar easily. Next time you're confronted with this dilemma, try placing a Post-it Note® in the approximate location of the intended hole and make your marks on that instead.

*Michael J. Burton
Glorieta, New Mexico*

Quick Tip

The three most popular band saw blades are the standard, skip and hook tooth. Standard blades have the most teeth and finest but slowest cuts. Skip tooth blades have half the number of teeth of a standard blade and cut faster but rougher. Hook tooth blades have evenly spaced, hooked teeth that are more aggressive yet.

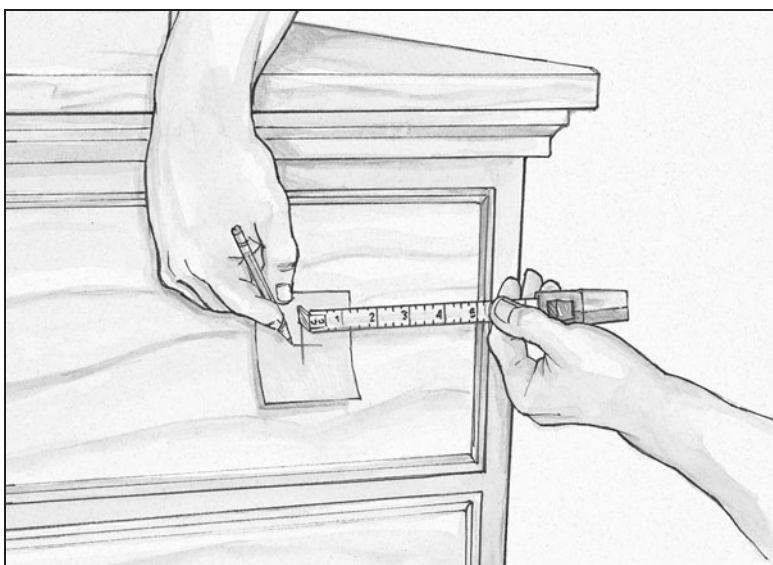

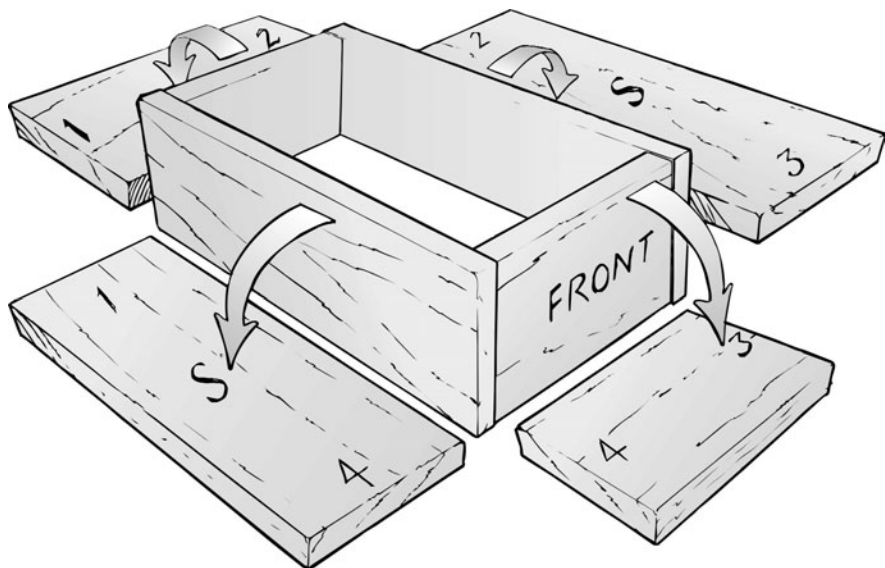

Q&A

"I see the guys on TV trim off their dowels and plugs with a strange-looking saw. Know where to get one?"

The saw you see is called a backsaw, and they are widely available in woodworking catalogs. The key to the one you're talking about is that the teeth have no set on one side, so they don't mar the work when used flush against it.

Placing Parts in the Dovetail Jig

I have over 30 years of woodworking experience and teach cabinetmaking and architectural woodworking at Utah Valley State College. As you can imagine, I have built and helped students build jillions of dovetailed drawers. One of the biggest problems students seem to have is keeping the parts in order and placing them correctly in the jig. The illustration above presents a simple system my students use to keep out of dovetail trouble.

*Robert F. Steele
Orem, Utah*

Screw Keeper

When changing the throat plate on my table saw, too frequently I dropped, lost or misplaced a screw. Now I bring a large magnet with me and stick all small metal parts to it.

*Martha Dawson
Squaw Valley, California*

Does your New Tape Measure Up?

When shopping for a tape measure, I open it up about six feet and double it over to see if all the incremental lines match up perfectly. Sometimes, it takes several shots before I find one that does.

*Michael Carroll
Sacramento, California*

Non-stick Drawer Guide

The drawer guide shown here is non-binding and has proved very practical after several years of use. The guide (A) is a piece of wood $1\frac{1}{8}$ " square, with a concave top. The groove is $\frac{3}{4}$ " wide and shallow enough that the drawer glides above the frame (B). The bottoms of the drawer sides are bullnosed to run in the groove, and the difference in the two arcs prevents binding when the wood dimensions change with the weather.

*George H. Swisher
Bowie, Maryland*

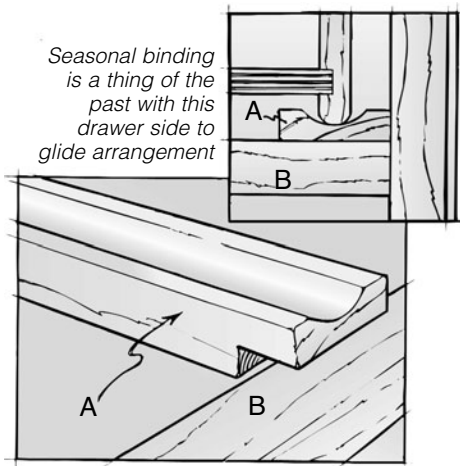

Quick Tip

Ok. The options are oil, ceramic and waterstones.

Take your pick. That choice

has become easier for

woodworkers in recent

years with huge

improvements in the quality

and array of waterstones.

They are cleaner to work

with than oilstones and

don't permanently spot the

wood. A diamond

waterstone costs a little

more, but it will remain flat

and true with minimum

maintenance (an occasional

cleaning), give service life

proportional to its cost, and

be available in a wide range

of sizes and grits. It can

even be used to flatten your

worn-out oilstones!

A steel drill fractional gauge clearly indicates the size of each of José's drill bits, and the wooden block holds them vertical

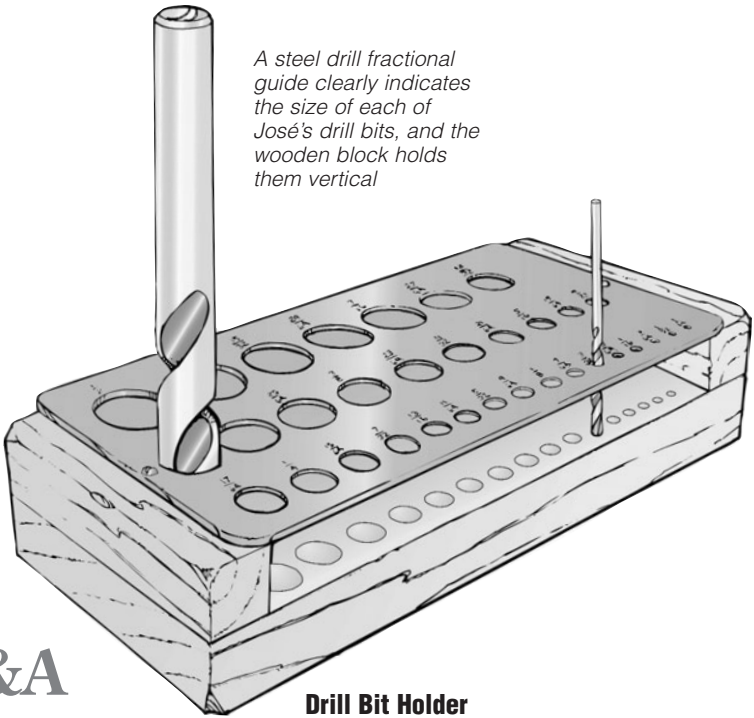

Q&A

"How do I stop the bearing burn when I trim laminate?"

The pros like to spread a very thin coat of petroleum jelly on the bearing of their flush trim bit before tackling this task. It generally won't interfere with finishes and, if the bearing sticks a little, the petroleum jelly will release it. You can also soak the bearing (but not the screw!) in oil between uses.

Drill Bit Holder

I bought a drill fractional gauge for \$2.97 from a mail order catalog. This is a 3" x 6" metal plate with holes ranging from 1/16" to 1/2", in 1/64" increments. I screwed the plate to two wood blocks glued to a wooden base, then drilled into the base using the gauge as a guide to make a 1/2" or 3/8" deep hole for each bit. The holes in the base hold the bits securely, and each bit is visibly numbered. I store them with the cutting end down for safety.

*José A Mari Mutt
Mayaguez, Puerto Rico*

But I Don't Do Windows

I use a metal-backed squeegee, the kind used for windows, to remove excess wood filler. Two coats of filler and two passes do a great job.

*Harry Tuttle III
Wayzata, Minnesota*

Mini Jig Knobs

Store bought knobs are too big for some jobs and often get in the way when used on my shop jigs. After failing to find smaller alternatives, I ended up making my own from electrical connection wire nuts and a handful of machine bolts. I removed the wire insert from each plastic nut cap by turning it counterclockwise with a screwdriver. Next, I filled the caps with epoxy and inserted the threaded end of machine bolts. Later, after the epoxy cured, I cut the bolts to length. Different sized wire nuts allowed me to use different thicknesses of machine bolts, all the way up to 1/4" diameter. Adding a rubber washer between the knob and jig increases the gripping strength.

*Tony Wladyka
Mountainside, New Jersey*

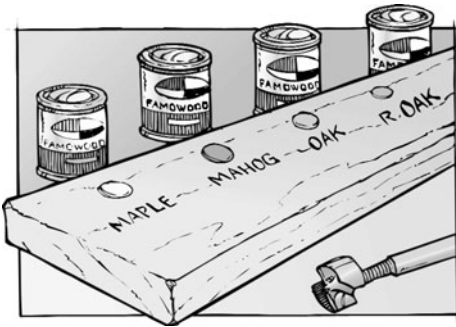

Wood Filler Color Template

Drill shallow holes with a small Forstner bit and fill them with every different wood putty you own, and you have an instant guide to what they'll look like dry, instead of depending on the color shown on the can.

*Martin Kipp
Albany, New York*

Quick Tip

If you don't own a drill press, keeping things vertical so the hole you drill is also vertical can be a problem. One way around this, at least for small parts, is to secure the part in a wooden handscrew clamp laid flat on the bench. The larger the clamp, the better. Clamp a pencil or drill bit in a second, smaller clamp and lay this on top of the first clamp. You now have a visual guide to help you keep the drilling operation vertical. You can even move it around to check from different angles. Just be sure the pencil truly is at 90° before you rely on it.

Q&A

“Do you have any tips for preparing a surface for prior to painting?”

We talked to Steve Jordan, the finishing expert at the Landmark Society in Rochester, New York, and he gave us these pointers. For shallow dents, polyester and epoxy fillers hold better than spackling or plastic woods. For a smooth finish on open grains, use a paste wood filler (not spackle) before priming. Whenever possible, keep the work surface horizontal, to avoid runs. And try tinting the primer the same color as your topcoat, for better coverage.

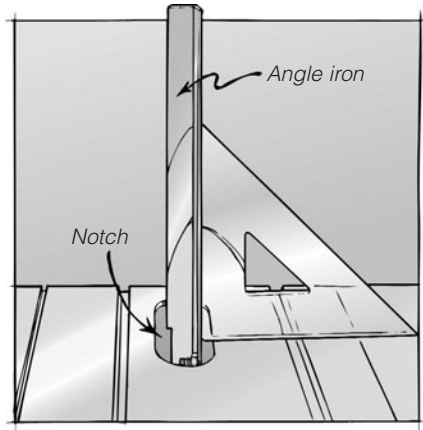

Setting Table Saw Stops

In setting up and checking the indicators on my table saw for 45° and 90°, I was always frustrated by the limitations imposed by using a saw blade as the guide. My solution is a 24" long section of extruded aluminum angle. It's inexpensive and widely available. To use it, begin by unplugging the saw! A 5/8" hole drilled a couple of inches up from one end allows you to replace the blade with the extrusion and secure it in place with the regular washer and nut. You may have to notch the extrusion to provide clearance for installation. Is that saw unplugged?

By using a 14" drafting triangle for setting the 45° and 90° angles, I now have a clear view and far more contact area. For intermediate angles, I use a machinist's protractor. A dial gauge between a flat metal bar in the miter slot and the aluminum extrusion provides a perfect parallel setting. Most angle extrusions are straight, but be sure to check yours anyway.

*Robert England
Eugene, Oregon*

Add Suction to your Radial Arm Saw

When I used to use my radial arm saw, the chips would fall on the table and floor. Fine dust would float in the air and get into the heating system, where it eventually found its way to the dining room table. My vacuum system never seemed to draw enough dust from the saw until I finally came up with this idea. The shield over the saw blade has an opening two inches wide and the air is divided across the whole expanse, leaving very little suction around the blade. The space is wide to accommodate a dado head and other cutters. All I did was fasten a piece of wood into the shield and around the hardware, and now I have plenty of suction.

*James Johnson
Brunswick, Ohio*

Quick Tip

If your tenons are just a hair too thick to fit in their mortises, try a traditional solution. You can shave them with a shoulder plane. That's a small metal plane (quite inexpensive and widely available) that essentially cuts across the grain, shaving the entire width of the plane.

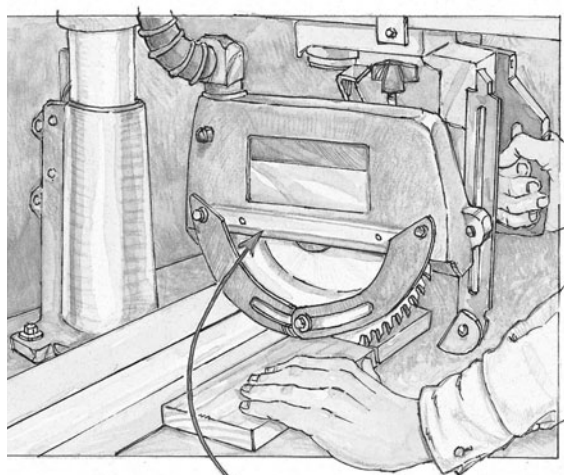

James Johnson mounted small wooden slats inside the blade aperture on his radial arm saw to reduce the airflow and increase the vacuum

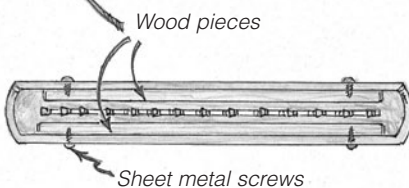

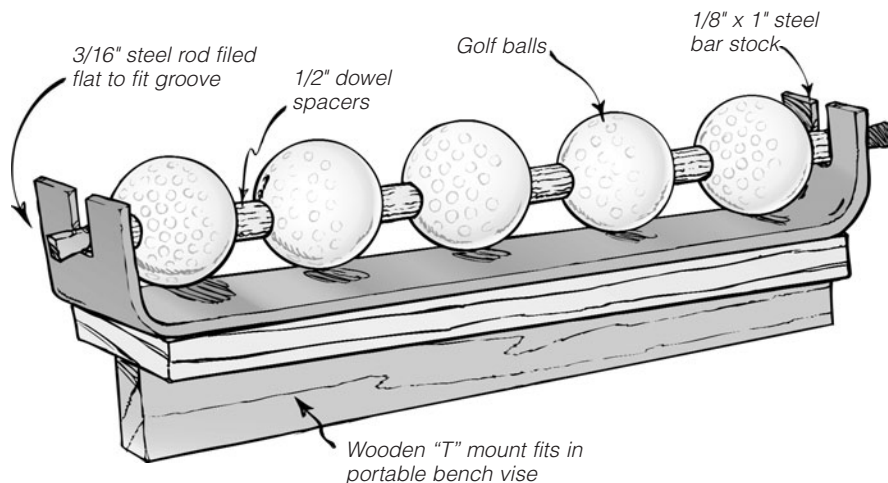

Q&A

"What's good about shellac?"

Though modern finishes have relegated shellac to the back burner, it remains one of the most easily repaired finishes available. As a thin wash coat, it is unsurpassed for sealing pine and other porous woods, and it still dries in an hour or two. The layers meld together too, reducing any chance of failure.

Golf Ball Outfeed Rollers

As you can see from the sketch above, I've created a handy, affordable outfeed roller setup with nothing but materials I had on hand. I began by going through my golf bag and selecting five more or less junk balls with smiles or other defects. I drilled a 1/4" hole through each ball, as well as through the 1/2" dowel I used as spacers. Then I hacksawed a slot on each end of a thin steel bar, drilled mounting holes and bent the ends at 90°.

A 3/16" steel rod was filed flat enough to slide snugly into the slots in the steel bar. Finally, all parts were assembled and mounted on a wooden "T" that I can clamp in my Workmate® at the right height for the outfeed of my saw.

P.S. Non-golfers shouldn't have any trouble getting used balls from golfing friends. Even if you have to buy used balls, they're very inexpensive.

*R. B. Himes
Vienna, Ohio*

Cork Sander Pads

The felt pad on my sander wore out, so I replaced it with two layers of 1/8" cork attached with contact cement. The cork wears longer, is flatter and doesn't rut as easily.

*Dick Dorn
Oelwein, Iowa*

A Shop-Built Router Stand

For safety reasons, I didn't like the idea of laying the router on its side, so I built this stand. I made it from 3/4" plywood and just glued everything together. I put carpet on the top for the router base to slide on. The 6" wide carpeted area is about 1/4" wider than the base of my router. This means I can slide my router on the stand while it's still coasting to a stop. The clearance below the router can be changed to match any length bit by just adding layers of plywood to the sides.

*Richard G. Lobaugh
Chesterfield, Virginia*

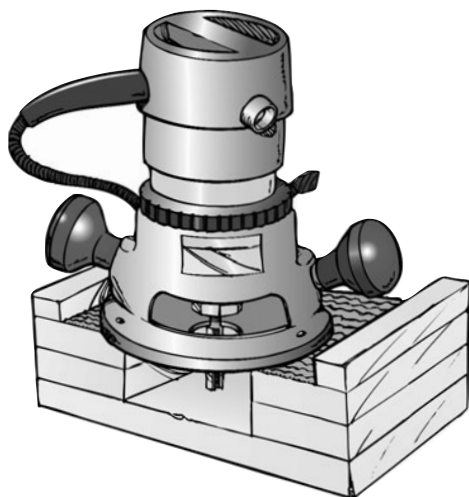

Quick Tip

Need to plane a small part?

Then clamp your jack plane upside down in the end vise of your workbench.

This way, the wood can be moved across the plane in full view, rather than trying to work on a part that is obscured by the body of the plane. If the part is so small that your fingers may contact the blade, then attach a handle to it. This handle can be a scrap of wood that is clamped on, or even one that is temporarily attached with hot-melt glue. Moving the wood rather than the plane has one other advantage: you can see when the mouth of the plane gets clogged, and where.

Closing Thoughts

If you liked what you found here ...

The tricks, tips, and jigs in this book were selected from back issues of Woodworker's Journal and Today's Woodworker magazine, (published from 1989 to 1998 and then merged with Woodworker's Journal).

*For more information about either magazine or our line of woodworking plans, please call us, toll-free, at **800-610-0883** or visit our web site: **www.woodworkersjournal.com***

Woodworker's Journal magazine:

Nearly the entire library of projects, covering almost 25 years, is available as individual reprints. Subscriptions to the magazine are available, as are subscriptions to our free online e-zine.

Rockler Woodworking and Hardware:

For Woodworking tools and supplies visit Rockler at rockler.com or call 1-800-279-4441.

Be Careful in Your Shop!

We at *Woodworker's Journal* have tried to make this book as accurate and correct as possible. The illustrations, diagrams and drawings, as well as the text, have been carefully researched by our in-house staff. However, due to the variability of local conditions, construction materials and personal skills, we assume no responsibility for any injuries, damages or other losses incurred that result from the material presented herein. All material presented should be carefully studied and clearly understood before attempting to duplicate techniques described.

For the sake of clarity, it is sometimes necessary for an illustration to show a power tool without its proper guards or safety equipment in place. In actual operation, always use the safety equipment provided with your tool by the manufacturer.

For over 30 years, woodworkers across the country have been sharing their favorite shortcuts, jigs and fixtures with the editors of Woodworker's Journal. Here are 250 of the best ideas we've presented in Woodworker's Journal magazine!

WOODWORKER'S JOURNAL

4365 Willow Drive, Medina, Minnesota 55340-0401

Phone: 800-610-0883

Web site address: www.woodworkersjournal.com