

INTERNATIONAL ADVANCED LEVEL

PHYSICS

SAMPLE ASSESSMENT MATERIALS

Pearson Edexcel International Advanced Subsidiary in Physics (XPH11)

Pearson Edexcel International Advanced Level in Physics (YPH11)

First teaching September 2018

First examination from January 2019

First certification from August 2019 (International Advanced Subsidiary)

and August 2020 (International Advanced Level)



Edexcel, BTEC and LCCI qualifications

Edexcel, BTEC and LCCI qualifications are awarded by Pearson, the UK's largest awarding body offering academic and vocational qualifications that are globally recognised and benchmarked. For further information, please visit our qualification website at qualifications.pearson.com. Alternatively, you can get in touch with us using the details on our contact us page at qualifications.pearson.com/contactus

About Pearson

Pearson is the world's leading learning company, with 35,000 employees in more than 70 countries working to help people of all ages to make measurable progress in their lives through learning. We put the learner at the centre of everything we do, because wherever learning flourishes, so do people. Find out more about how we can help you and your learners at qualifications.pearson.com

References to third party material made in this sample assessment materials are made in good faith. Pearson does not endorse, approve or accept responsibility for the content of materials, which may be subject to change, or any opinions expressed therein. (Material may include textbooks, journals, magazines and other publications and websites.)

All information in this document is correct at time of publication.

ISBN 978 1 446 94606 0

All the material in this publication is copyright

© Pearson Education Limited 2017

Contents

Introduction	1
General marking guidance	3
Unit 1 – Question paper	5
Unit 1 – Mark scheme	29
Unit 2 – Question paper	39
Unit 2 – Mark scheme	63
Unit 3 – Question paper	73
Unit 3 – Mark scheme	85
Unit 4 – Question paper	91
Unit 4 – Mark scheme	113
Unit 5 – Question paper	123
Unit 5 – Mark scheme	145
Unit 6 – Question paper	157
Unit 6 – Mark scheme	173

Introduction

The Pearson Edexcel International Advanced Subsidiary in Physics and the Pearson Edexcel International Advanced Level in Physics are part of a suite of International Advanced Level qualifications offered by Pearson.

These sample assessment materials have been developed to support these qualifications and will be used as the benchmark to develop the assessment students will take.

General marking guidance

- All candidates must receive the same treatment. Examiners must mark the last candidate in exactly the same way as they mark the first.
- Mark schemes should be applied positively. Candidates must be rewarded for what they have shown they can do rather than be penalised for omissions.
- Examiners should mark according to the mark scheme – not according to their perception of where the grade boundaries may lie.
- All the marks on the mark scheme are designed to be awarded. Examiners should always award full marks if deserved, i.e. if the answer matches the mark scheme. Examiners should also be prepared to award zero marks if the candidate's response is not worthy of credit according to the mark scheme.
- Where some judgement is required, mark schemes will provide the principles by which marks will be awarded and exemplification/indicative content will not be exhaustive. However different examples of responses will be provided at standardisation.
- When examiners are in doubt regarding the application of the mark scheme to a candidate's response, a senior examiner must be consulted before a mark is given.
- Crossed-out work should be marked **unless** the candidate has replaced it with an alternative response.

Write your name here

Surname

Other names

**Pearson Edexcel
International
Advanced Level**

Centre Number

--	--	--	--	--	--

Candidate Number

--	--	--	--	--	--

Physics

**International Advanced Subsidiary/Advanced Level
Unit 1: Mechanics and Materials**

Sample Assessment Materials for first teaching September 2018

Time: 1 hour 30 minutes

Paper Reference

WPH11/01

You must have:

Scientific calculator, ruler, protractor

Total Marks

Instructions

- Use **black** ink or **black** ball-point pen.
- **Fill in the boxes** at the top of this page with your name, centre number and candidate number.
- Answer **all** questions.
- Answer the questions in the spaces provided – *there may be more space than you need.*
- **Show all your working in calculations and include units where appropriate.**

Information

- The total mark for this paper is 80.
- The marks for **each** question are shown in brackets – *use this as a guide as to how much time to spend on each question.*
- In questions marked with an **asterisk (*)**, marks will be awarded for your ability to structure your answer logically showing how the points that you make are related or follow on from each other where appropriate.

Advice

- Read each question carefully before you start to answer it.
- Try to answer every question.
- Check your answers if you have time at the end.

Turn over ►

S58680A

©2018 Pearson Education Ltd.

1/1/1/1/



Pearson

SECTION A

Answer ALL questions.

For questions 1–10, select one answer from A to D and put a cross in the box ☒.
If you change your mind, put a line through the box ~~☒~~ and then
mark your new answer with a cross ☒.

1 Quantities can be scalar or vector.

Select the row of the table that correctly states a scalar quantity and a vector quantity.

	Scalar quantity	Vector quantity
<input type="checkbox"/> A	mass	momentum
<input type="checkbox"/> B	momentum	weight
<input type="checkbox"/> C	speed	mass
<input type="checkbox"/> D	weight	speed

(Total for Question 1 = 1 mark)

2 As lava leaves a volcano it cools down.

Select the row of the table that correctly describes the effect of a lower temperature on the viscosity and rate of flow of lava.

	Viscosity	Rate of flow
<input type="checkbox"/> A	decreases	decreases
<input type="checkbox"/> B	decreases	increases
<input type="checkbox"/> C	increases	increases
<input type="checkbox"/> D	increases	decreases

(Total for Question 2 = 1 mark)

DO NOT WRITE IN THIS AREA

DO NOT WRITE IN THIS AREA

DO NOT WRITE IN THIS AREA

- 3 A car is travelling at a velocity v . The driver applies the brakes and the car decelerates until it comes to rest. The work done by the brakes on the car is W .

Which of the following expressions is correct?

- A $W \propto v$
- B $W \propto v^2$
- C $W \propto \frac{1}{v}$
- D $W \propto \frac{1}{v^2}$

(Total for Question 3 = 1 mark)

- 4 A man applies a force F to a box and the box accelerates. The forces acting on the box are shown on the diagram.

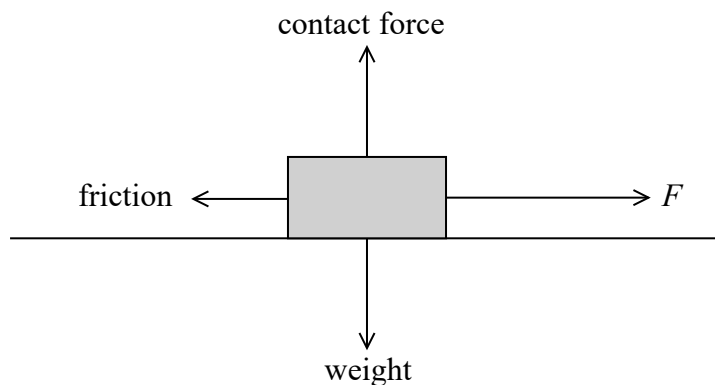

According to Newton's third law, the box will exert a force on the man.

Select the row of the table that correctly describes the magnitude and direction of the force of the box on the man.

- | | Magnitude | In the direction of |
|----------------------------|-----------|---------------------|
| <input type="checkbox"/> A | F | F |
| <input type="checkbox"/> B | F | friction |
| <input type="checkbox"/> C | friction | F |
| <input type="checkbox"/> D | friction | friction |

(Total for Question 4 = 1 mark)

5 The photograph shows the flow of air around the wing of an aeroplane.

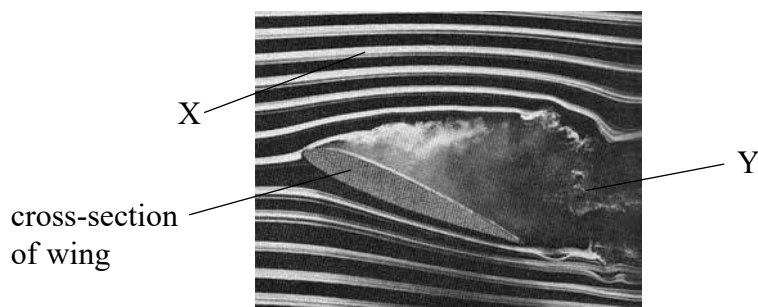

Source from: <http://ffden 2.phys.uaf.edu/211.fall2000.web.projects/c.%20Schaefer/aero4.htm>

X and Y are two points in the path of the air flow.

Which of the following statements about the speed of the air is correct?

- A The speed of the air at X is constant.
- B The speed of the air at X is continuously changing.
- C The speed of the air at X is equal to the speed of the air at Y.
- D The speed of the air at Y is constant.

(Total for Question 5 = 1 mark)

6 A ball is dropped from a window and takes 1.6 s to reach the ground.

Which of the following is the height of the window?

- A 8 m
- B 13 m
- C 16 m
- D 25 m

(Total for Question 6 = 1 mark)

DO NOT WRITE IN THIS AREA

DO NOT WRITE IN THIS AREA

DO NOT WRITE IN THIS AREA

Questions 7 and 8 refer to the following information.

Increasing forces were applied across the ends of a wire and the corresponding extensions recorded. A force-extension graph was plotted for the wire.

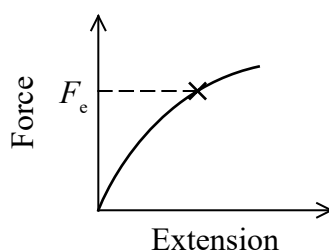

7 The point marked \times is the elastic limit of the wire.

Which of the following statements is **not** correct?

- A F_e is the maximum force at which the wire behaves elastically.
- B F_e is the maximum force at which the wire obeys Hooke's law.
- C F_e is the minimum force at which the wire permanently deforms.
- D F_e is the minimum force at which the wire behaves plastically.

(Total for Question 7 = 1 mark)

8 The force on the wire was then decreased and the corresponding extensions recorded. The values were plotted onto the same axes.

Which of the following is the correct graph?

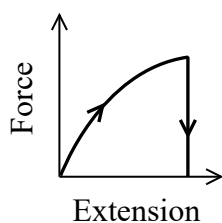

A

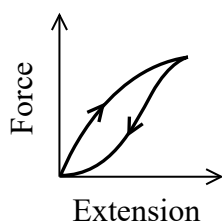

B

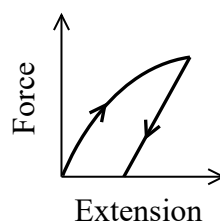

C

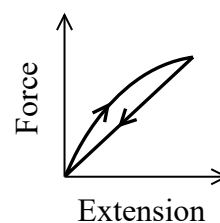

D

(Total for Question 8 = 1 mark)

Questions 9 and 10 refer to the following information.

A student carries out a practical to determine the viscosity η of a liquid. A small metal sphere of radius r is dropped into a cylinder of the liquid.

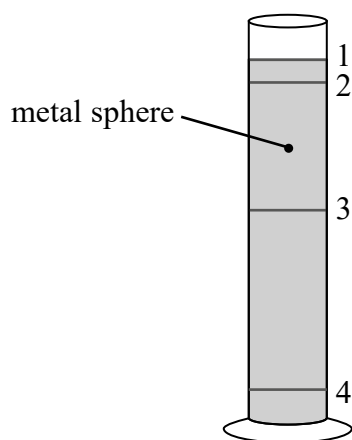

- 9 Elastic bands are placed around the cylinder in the positions 1, 2, 3 and 4 as shown. The time taken for the sphere to fall between two of the elastic bands is going to be recorded.

Which of the following are the best two elastic bands to use?

- A 1 and 3
 B 2 and 4
 C 1 and 4
 D 3 and 4

(Total for Question 9 = 1 mark)

- 10 The sphere is made from a metal of density ρ_M and the liquid has density ρ_L .

Which of the following expressions correctly gives the forces acting on the sphere when travelling at a terminal velocity v through the liquid?

- A $6\pi\eta rv + \frac{4}{3}\pi r^3\rho_L g + \frac{4}{3}\pi r^3\rho_M g = 0$
 B $6\pi\eta rv - \frac{4}{3}\pi r^3\rho_L g - \frac{4}{3}\pi r^3\rho_M g = 0$
 C $6\pi\eta rv - \frac{4}{3}\pi r^3\rho_L g + \frac{4}{3}\pi r^3\rho_M g = 0$
 D $6\pi\eta rv + \frac{4}{3}\pi r^3\rho_L g - \frac{4}{3}\pi r^3\rho_M g = 0$

(Total for Question 10 = 1 mark)

TOTAL FOR SECTION A = 10 MARKS

SECTION B

Answer ALL questions.

- 11 A student carried out an experiment to determine the Young modulus of a material in the form of a wire. The student set up the apparatus as shown.

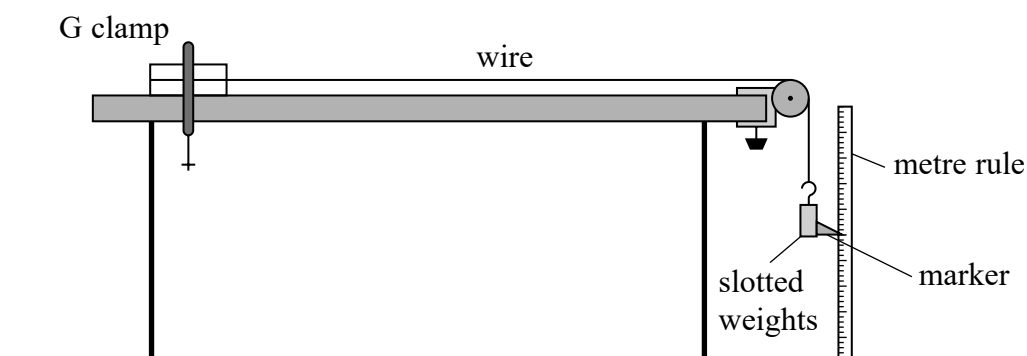

The initial length of the wire was measured. Slotted weights of known values were added to the hanger at the free end of the wire. Each time a weight was added, the new position of the marker was read from the metre rule and the extension calculated.

Describe a graphical method that the student should use to obtain a value for the Young modulus. State the additional measurement that would have to be taken.

(5)

(Total for Question 11 = 5 marks)

12 Two trolleys, A and B, are placed on a smooth track so that they are touching. When a peg is tapped on trolley A, a spring inside trolley A is released and the trolleys move apart.

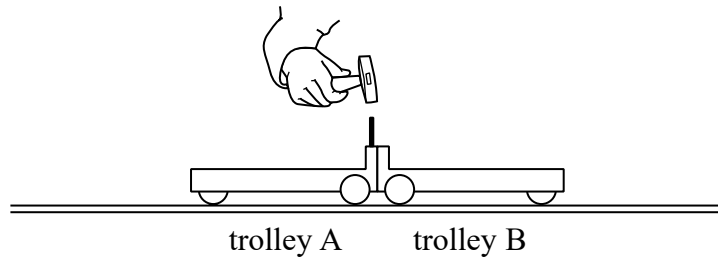

(a) Explain why the two trolleys move apart when the spring is released.

(2)

.....

.....

.....

.....

.....

(b) Explain which trolley will move off with the greater speed.

mass of trolley A = 0.1 kg
mass of trolley B = 0.2 kg

(3)

.....

.....

.....

.....

.....

.....

(Total for Question 12 = 5 marks)

DO NOT WRITE IN THIS AREA

DO NOT WRITE IN THIS AREA

DO NOT WRITE IN THIS AREA

DO NOT WRITE IN THIS AREA

DO NOT WRITE IN THIS AREA

DO NOT WRITE IN THIS AREA

13 Child P throws a ball towards child Q at a speed of 20 m s^{-1} at an angle of 75° to the horizontal.

While this ball is in the air, child P throws a second ball, also at a speed of 20 m s^{-1} at an angle of 15° to the horizontal. Both balls reach child Q at the same time.

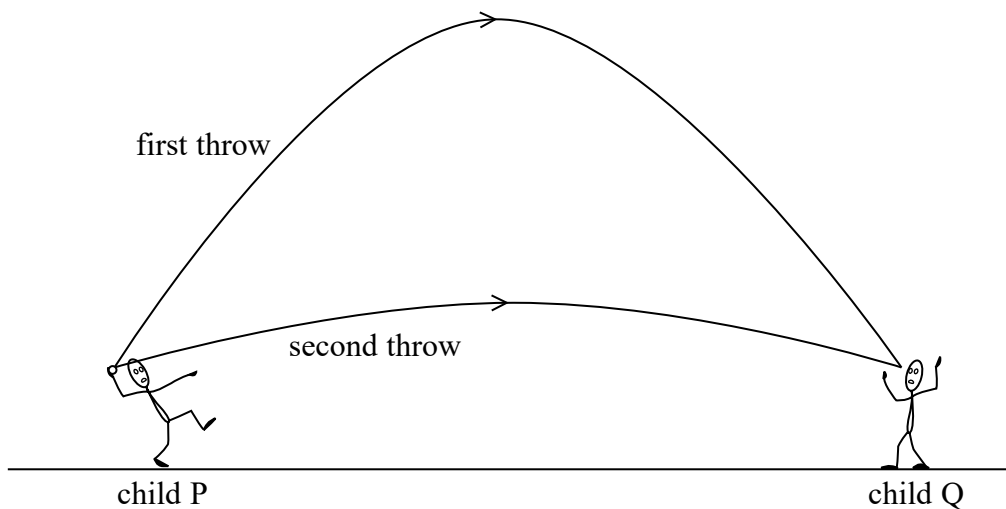

Determine how long the child P should wait before throwing the second ball.

(4)

.....

.....

.....

.....

.....

.....

.....

.....

.....

.....

.....

Time between throws =

(Total for Question 13 = 4 marks)

14 A musical instrument called a triangle consists of a metal bar bent into a triangular shape. The triangle is open at one corner. A full size diagram of a triangle is shown below. The position of the centre of gravity has been added.

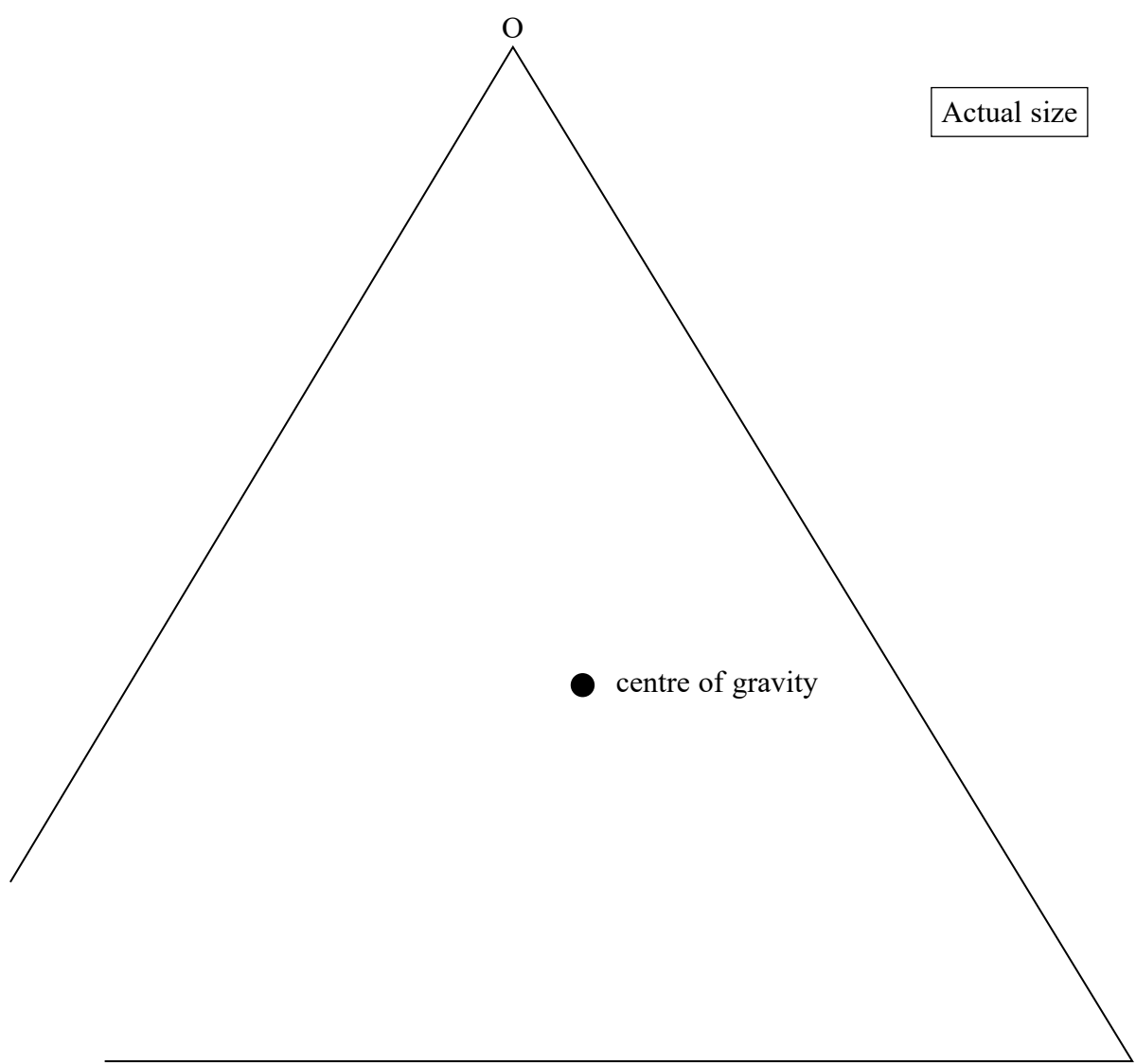

(a) State what is meant by centre of gravity.

(1)

.....

.....

.....

DO NOT WRITE IN THIS AREA

DO NOT WRITE IN THIS AREA

DO NOT WRITE IN THIS AREA

DO NOT WRITE IN THIS AREA

DO NOT WRITE IN THIS AREA

DO NOT WRITE IN THIS AREA

(b) Determine the moment of the weight of the triangle about O.

mass of triangle = 0.180 kg

(4)

.....

.....

.....

.....

.....

.....

.....

.....

.....

.....

Moment of weight of the triangle =

(c) The triangle is now suspended by a thread from O.

Explain why the triangle settles in a position where the base is no longer horizontal.

(2)

.....

.....

.....

.....

.....

.....

.....

.....

.....

.....

(Total for Question 14 = 7 marks)

15 The diagram shows a ship used to carry heavy loads. Two tug boats are used to guide the ship into port applying forces as shown.

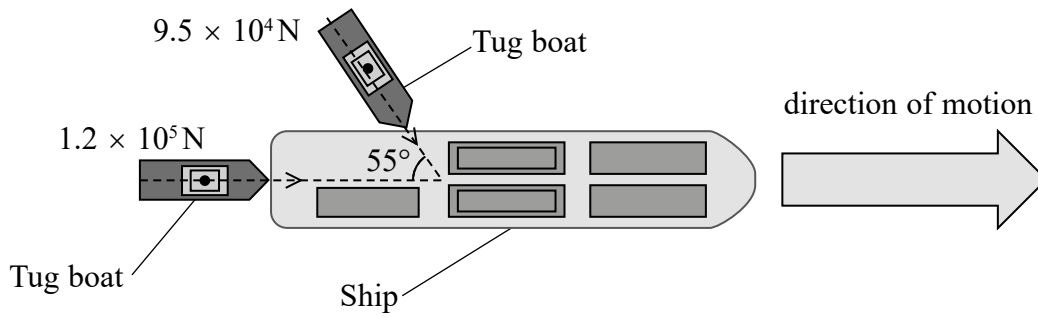

(a) Draw a vector diagram to determine the resultant force acting on the ship due to the tug boats. (4)

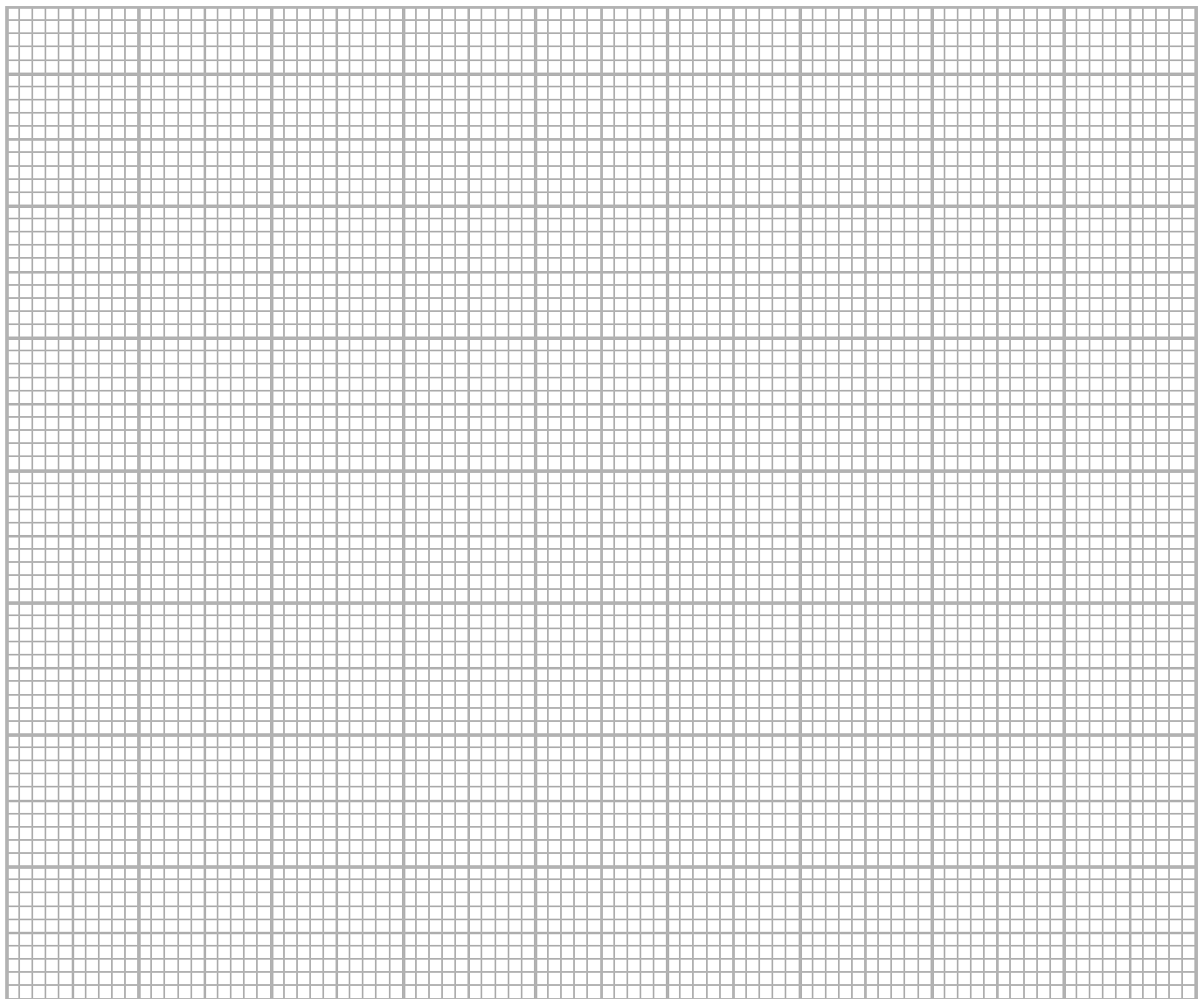

Magnitude of resultant force =

Direction of resultant force =

DO NOT WRITE IN THIS AREA

DO NOT WRITE IN THIS AREA

DO NOT WRITE IN THIS AREA

(b) The ship has a velocity of 4.00 m s^{-1} in the direction of the $1.2 \times 10^5 \text{ N}$ force.

- (i) Calculate the rate at which work is done on the ship by the tug boat that provides the $1.2 \times 10^5 \text{ N}$ force.

(2)

.....

.....

.....

.....

Rate at which work is done =

- (ii) This tug boat has two engines, each of power 950 kW .

Calculate the efficiency of this tug boat in pushing the ship.

(2)

.....

.....

.....

.....

Efficiency =

(Total for Question 15 = 8 marks)

- (b) Draw an acceleration-time graph on the axes below for the motion of the ball from time = 0 to time t_3 . You can ignore any temporary change in acceleration on impact with the ground.

(2)

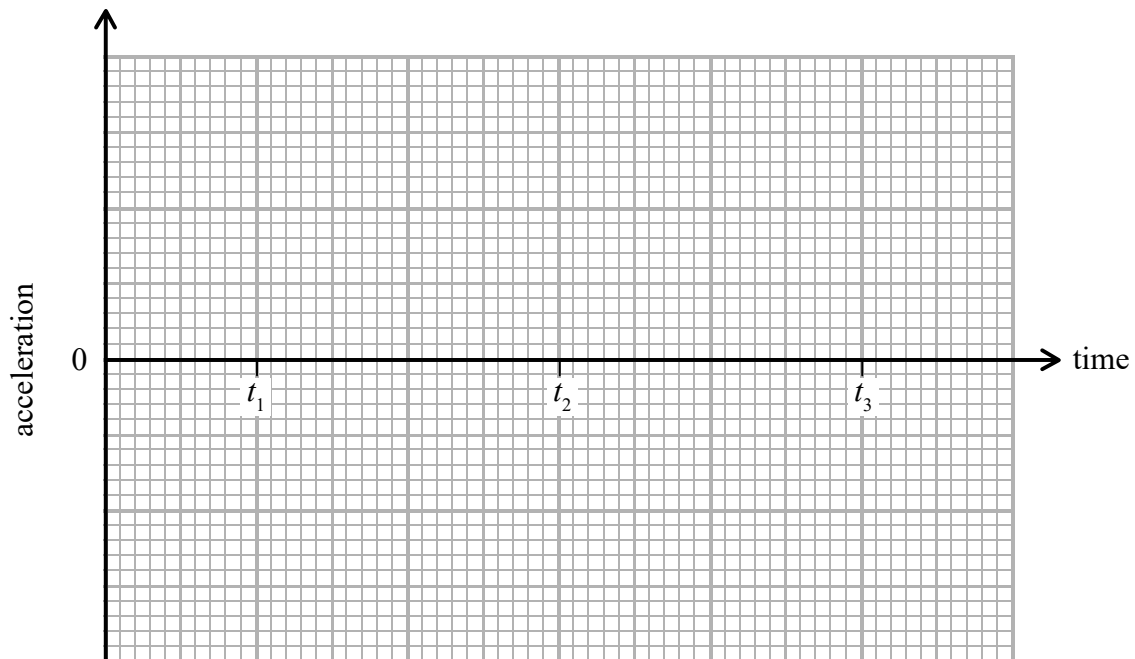

(Total for Question 16 = 6 marks)

17 A student is investigating a spring.

He uses the steel disc shown in the diagram.

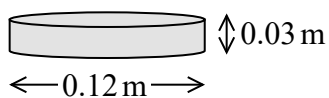

(a) Show that the weight of the disc is about 26 N.

density of steel = 7900 kg m^{-3}

(4)

.....

.....

.....

.....

.....

.....

.....

.....

.....

.....

(b) The student drops the disc from a height of 0.300 m onto a spring. The original length of the spring is 0.110 m. The maximum compression of the spring when the disc lands on it is 0.060 m

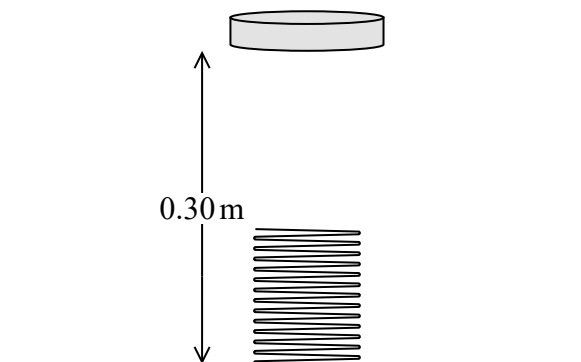

(i) Calculate the change in gravitational potential energy of the disc between when the disc is released and when the spring has maximum compression.

(3)

.....

.....

.....

.....

Change in gravitational potential energy =

(ii) Hence calculate the maximum force that the disc exerts on the spring at maximum compression.

(2)

.....

.....

.....

.....

Maximum force on spring =

(iii) Hence, determine the stiffness of the spring.

(2)

.....

.....

.....

.....

Stiffness of spring =

(Total for Question 17 = 11 marks)

DO NOT WRITE IN THIS AREA

DO NOT WRITE IN THIS AREA

DO NOT WRITE IN THIS AREA

18 Kevlar is a modern lightweight material. Due to its physical properties, Kevlar is being used to replace nylon and steel in many applications.

The stress-strain graphs for Kevlar, nylon and steel are shown.

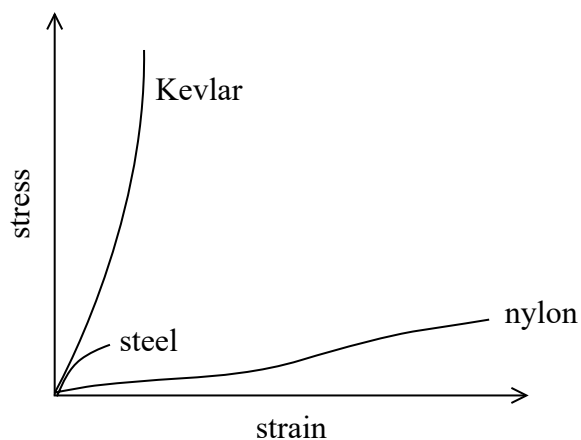

(a) When pulling a heavy load, Kevlar cables are now often used instead of nylon cables.

Explain two advantages of using Kevlar in cables compared to using nylon.

(4)

.....

.....

.....

.....

.....

.....

.....

.....

.....

.....

- (b) The photograph shows a machine used for surveying the seabed. A communications cable connects the machine to a ship on the surface.

communications cable



Source from: http://www2.dupont.com/Personal_Protection/en_GB/assets/PDF/OandG/Nexans%20Case%20Study.pdf

The material used in the outer casing of the communications cable must withstand the large pressures at the seabed, yet be light enough to lift out of the water.

density of Kevlar = 1400 kg m^{-3}

density of steel = 7800 kg m^{-3}

- (i) Deduce whether steel or Kevlar is more suitable to use in the outer casing of a communications cable at the seabed.

(4)

- (ii) Due to the effects of upthrust, the ‘apparent’ weight of a cable in seawater is less than it is in air.

Calculate the ‘apparent’ weight of a sample of Kevlar of volume $8.5 \times 10^{-3} \text{ m}^3$ in seawater.

Density of seawater = 1030 kg m^{-3}

(4)

.....

.....

.....

.....

.....

.....

.....

.....

.....

.....

(Total for Question 18 = 12 marks)

DO NOT WRITE IN THIS AREA

DO NOT WRITE IN THIS AREA

DO NOT WRITE IN THIS AREA

DO NOT WRITE IN THIS AREA

DO NOT WRITE IN THIS AREA

DO NOT WRITE IN THIS AREA

19 A yo-yo is a toy that consists of two connected discs on a piece of string.



© homydesign/Shutterstock

A child stands in a stationary train holding a yo-yo. The train accelerates and the string moves into the position shown, at an angle θ to the vertical.

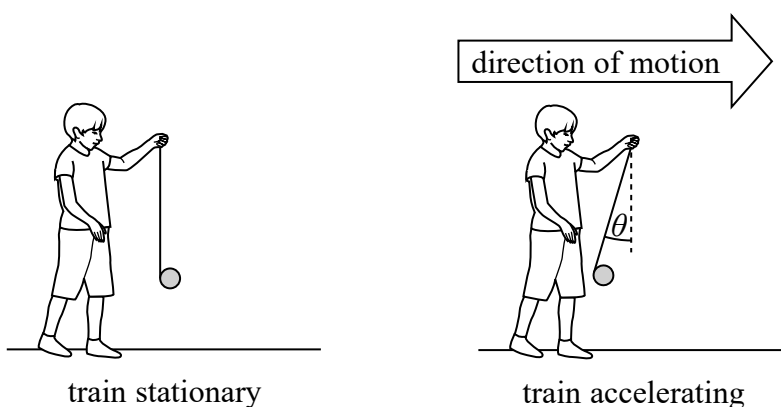

(a) Draw the free-body force diagram for the yo-yo when the train is accelerating.

(2)



(b) Calculate the acceleration of the train by resolving horizontally and vertically for the forces on the yo-yo.

mass of yo-yo = 0.050 kg

$\theta = 8.0^\circ$

(4)

.....

.....

.....

.....

.....

.....

.....

.....

Acceleration of the train =

DO NOT WRITE IN THIS AREA

DO NOT WRITE IN THIS AREA

DO NOT WRITE IN THIS AREA

BLANK PAGE

Unit 1: Mechanics and Materials - Mark scheme

Question number	Answer	Mark
1	A	1
2	D	1
3	B	1
4	B	1
5	A	1
6	B	1
7	B	1
8	C	1
9	D	1
10	D	1

Question number	Answer	Mark
11	<p>Either</p> <ul style="list-style-type: none"> • Additional measurement: diameter of wire (1) • Plot a graph of the applied weight on the y-axis against the extension on the x-axis (1) • Calculate the gradient of linear region (1) • Calculate the cross-sectional area of the wire using $\pi d^2/4$ (1) • $E = \text{gradient} \times \frac{\text{original length}}{\text{cross sectional area}}$ (1) <p>Or</p> <ul style="list-style-type: none"> • Additional measurement: diameter of wire (1) • Calculate the cross-sectional area of the wire using $\pi d^2/4$ (1) • Calculate the stress for each applied force using force/area and the strain using $\frac{\text{extension}}{\text{original length}}$ (1) • Plot a graph of stress on the y-axis against strain on the x-axis (1) • Gradient of linear region = E (1) 	5
Total for Question 11		5

Question number	Answer	Mark
12(a)	<ul style="list-style-type: none"> As the spring is released it extends and applies a force to trolley B (1) Then due to N3, trolley B applies an equal and opposite force to trolley A (1) 	2
12(b)	<p>Either</p> <ul style="list-style-type: none"> Total initial momentum = 0 (1) $0.1v_A - 0.2v_B = 0$ (1) $v_A = 2v_B$ so trolley A has the greater speed (1) <p>Or</p> <ul style="list-style-type: none"> Total initial momentum = 0 (1) Trolleys will have equal and opposite momenta (1) Lighter trolley A has the greater speed (1) 	3
Total for Question 12		5

Question number	Answer	Mark
13	<ul style="list-style-type: none"> Use of trig to determine the initial vertical velocity Or see $20\cos 75$ Or see $20\cos 15$ (1) Use of equation(s) of motion to determine the time for either the first ball or the second ball (1) Use of $t_2 - t_1$ using candidate's values for t_1 and t_2 (1) Time difference = 2.9 s (1) <p><u>Example of calculation</u> If t_1 and t_2 represent the time for the balls to travel from child P to Q</p> <p><u>Equation for first ball</u></p> $0 = (20 \text{ m s}^{-1} \times \sin 75)t_1 + (\frac{1}{2}gt_1^2)$ $t_1 = 3.94 \text{ s}$ <p><u>Equation for second ball</u></p> $0 = (20 \text{ m s}^{-1} \times \sin 15)t_2 + (\frac{1}{2}gt_2^2)$ $t_2 = 1.06 \text{ s}$ $t_1 - t_2 = 3.94 \text{ s} - 1.06 \text{ s} = 2.88 \text{ s}$	4
Total for Question 13		4

Question number	Answer	Mark
14(a)	The point through which the <u>weight</u> appears to act	(1) 1
14(b)	<ul style="list-style-type: none"> • Measurement of the perpendicular distance of the line of action of the weight from O (1) • Use of $W = mg$ (1) • Use of moment = force \times perpendicular distance from the pivot (1) • Moment = 0.023 N m (1) <p><u>Example of calculation</u></p> <p>Perpendicular distance = 1.3 cm</p> <p>Weight of triangle = $0.180 \text{ kg} \times 9.81 \text{ N kg}^{-1} = 1.77 \text{ N}$</p> <p>Moment of weight of the triangle = $1.77 \text{ N} \times (0.013 \text{ m}) = 0.023 \text{ N m}$</p>	4
14(c)	<ul style="list-style-type: none"> • The centre of gravity is now vertically below O (1) • Or the perpendicular distance of the weight from O is now zero • So there is no longer a moment for the weight about O (1) 	2
Total for Question 14		7

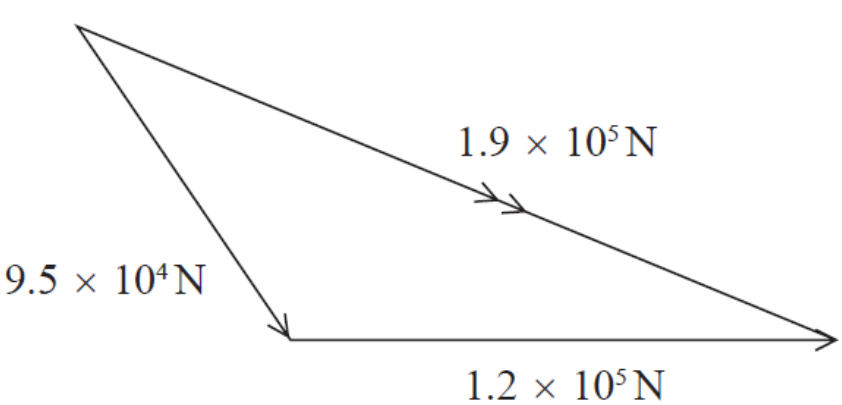
Question number	Answer	Mark
15(a)	<ul style="list-style-type: none"> Construction of correct (shape) vector diagram with resultant (1) $9.5 \times 10^4 \text{ N}$ and $1.2 \times 10^5 \text{ N}$ sides labelled with directions (1) <p><u>Magnitude of resultant force</u></p> <ul style="list-style-type: none"> $1.9 \times 10^5 \text{ N} \pm 0.2 \text{ N}$ (1) <p><u>Direction of resultant force</u></p> <ul style="list-style-type: none"> 24° to the direction of the $1.2 \times 10^5 \text{ N}$ force Or 31° to the direction of the $9.5 \times 10^4 \text{ N}$ force (1) 	4
15(b)(i)	<ul style="list-style-type: none"> Use of $\Delta W = F\Delta s$ and $P = \frac{W}{t}$ (1) $P = 4.8 \times 10^5 \text{ W}$ (1) <p><u>Example of calculation</u></p> $\text{Power} = \frac{1.2 \times 10^5 \text{ N} \times 4.0 \text{ m}}{1 \text{ s}} = 4.8 \times 10^5 \text{ W}$	2
15(b)(ii)	<ul style="list-style-type: none"> Use of efficiency = $\frac{\text{useful power output}}{\text{total power input}}$ (1) <p>MP1: accept use of a single power for the boat</p> <ul style="list-style-type: none"> Efficiency = 0.25 or 25 % ecf for candidate's power from (b)(i) (1) <p><u>Example of calculation</u></p> $\text{Efficiency} = \frac{4.8 \times 10^5 \text{ W}}{2 \times 950 \times 10^3 \text{ W}} = 0.25$	2
Total for Question 15		8

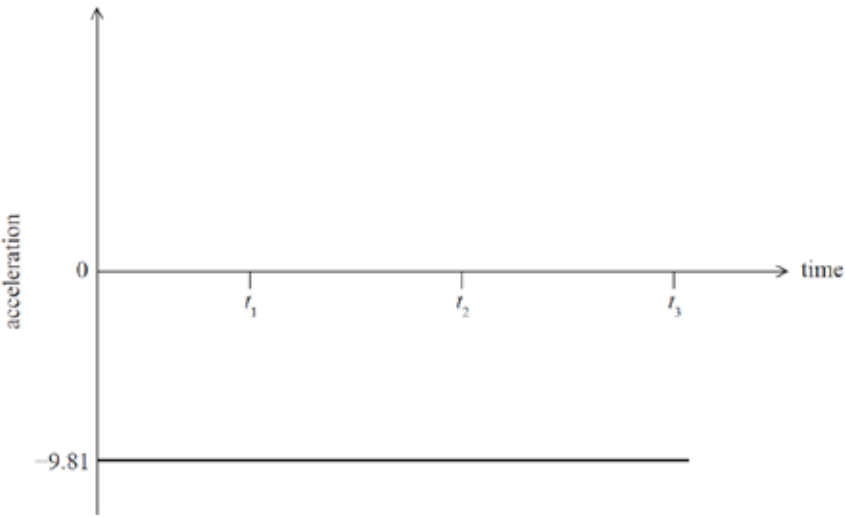
Question number	Answer	Mark
16(a)	<p>When the ball is in the air it always has a constant negative/downward acceleration (1)</p> <p>Any 3 from</p> <ul style="list-style-type: none"> • At t_1: the ball reaches the maximum height Or the ball changes its direction (1) • From t_1 to t_2: the ball is falling (1) • At t_2: the ball bounces (1) • From t_2 to t_3: the ball moves upwards to its maximum height (1) • At t_1 and t_3: The height of the ball is the same (1) 	4
16(b)	<ul style="list-style-type: none"> • Straight, horizontal line (1) • Drawn at $-9.81 \text{ (m s}^{-2}\text{)}$ (Accept -9.8 or -10 for the acceleration (MP2)) (1) 	2
Total for Question 16		6

Question number	Answer	Mark
17(a)	<ul style="list-style-type: none"> • Use of $V = \pi r^2 h$ (1) • Use of $\rho = m/V$ (1) • Use of $W = mg$ (1) • $W = 26.3 \text{ N}$ (1) <p><u>Example of calculation</u></p> $V = \pi \times (0.06 \text{ m})^2 \times 0.03 \text{ m} = 3.39 \times 10^{-4} \text{ m}^3$ $m = 7900 \text{ kg m}^{-3} \times 3.39 \times 10^{-4} \text{ m}^3 = 2.68 \text{ kg}$ $W = 2.68 \text{ kg} \times 9.81 \text{ N kg}^{-1} = 26.3 \text{ N}$	4
17(b)(i)	<ul style="list-style-type: none"> • Use of $E_{\text{grav}} = mg\Delta h$ (1) • Using $\Delta h = 0.19 \text{ m} + 0.06 \text{ m}$ (1) • Use of $E_{\text{grav}} = 6.6 \text{ J}$ (1) <p><u>Example of calculation</u></p> $E_{\text{grav}} = 26.3 \text{ N} \times (0.19 \text{ m} + 0.06 \text{ m}) = 6.58 \text{ J}$	3
17(b)(ii)	<ul style="list-style-type: none"> • Use of $\Delta E_{\text{el}} = \frac{1}{2} F\Delta x$ (1) • $F = 220 \text{ N}$ (1) <p><u>Example of calculation</u></p> $6.58 \text{ J} = \frac{1}{2} F \times 0.06 \text{ m}$ $F = 219.3 \text{ N}$	2
17(b)(iii)	<ul style="list-style-type: none"> • Use of $F = k\Delta x$ (1) • $k = 3700 \text{ N kg}^{-1}$ (1) <p><u>Example of calculation</u></p> $220 = k \times 0.06 \text{ m}$ $k = 3667 \text{ N kg}^{-1}$	2
Total for Question 17		11

Question number	Answer	Mark
18(a)(i)	<ul style="list-style-type: none"> • Kevlar is stiffer Or greater Young modulus (1) • so the extension is much smaller (under the same load) (1) • Kevlar has a greater <u>breaking stress</u> (1) • so is stronger (1) <p>MP2 is conditional on MP1 and MP4 is conditional on MP3</p>	4
18(b)(i)	<ul style="list-style-type: none"> • A thinner casing could be used with Kevlar to provide the same stress/strength as a thicker casing made of steel (1) • Kevlar is more suitable because it has a greater breaking stress Or Kevlar is more suitable because it is stronger (1) • For the same thickness of casing the weight of the cable using Kevlar would be much less than using steel for the casing (1) • Kevlar would be more suitable than steel for the casing (1) <p>MP5 is dependent on gaining MP2 and MP4</p>	4
18(b)(ii)	<ul style="list-style-type: none"> • upthrust = $\rho_w Vg$ Or weight of sample = $\rho_K Vg$ (1) • ‘Apparent’ weight = weight of sample – upthrust (1) • Use of weight of sample – upthrust (1) • Apparent weight = 31 N (1) <p><u>Example of calculation</u> Apparent weight = $(1400 \text{ kg m}^{-3} \times 8.5 \times 10^{-3} \text{ m}^3 \times 9.81 \text{ N kg}^{-1}) - (1030 \text{ kg m}^{-3} \times 8.5 \times 10^{-3} \text{ m}^3 \times 9.81 \text{ N kg}^{-1}) = 30.9 \text{ N}$</p>	4
Total for Question 18		12

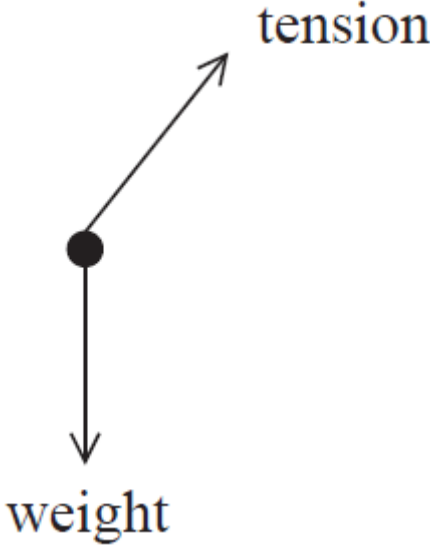
Question number	Answer	Mark
19(a)	<ul style="list-style-type: none"> • Weight/W/mg labelled (1) • Tension/T (1) <div style="text-align: center; margin-top: 20px;">  </div>	2
19(b)	<ul style="list-style-type: none"> • $T\cos\theta = mg$ (1) • $T\sin\theta = ma$ (1) • Combining the two equations eg $\tan\theta = a/g$ (1) • $a = 1.4 \text{ m s}^{-2}$ (1) <p><u>Example of calculation</u> Resultant force in vertical direction $T\cos 8^\circ = (0.050 \text{ kg} \times 9.81 \text{ N kg}^{-1})$</p> <p>Resultant force in horizontal direction $T\sin 8^\circ = (0.050 \text{ kg})a$</p> $\tan 8^\circ = \frac{0.050 \text{ kg} \times a}{0.050 \text{ kg} \times 9.81 \text{ N kg}^{-1}}$ $a = 1.38 \text{ m s}^{-2}$	4

Question number	Answer	Mark																				
19(c)	<p>This question assesses a student’s ability to show a coherent and logically structured answer with linkages and fully-sustained reasoning.</p> <p>Marks are awarded for indicative content and for how the answer is structured and shows lines of reasoning.</p> <p>The following table shows how the marks should be awarded for indicative content.</p> <table border="1" data-bbox="300 573 759 887"> <thead> <tr> <th>Number of indicative marking points seen in answer</th> <th>Number of marks awarded for indicative marking points</th> </tr> </thead> <tbody> <tr> <td>6</td> <td>4</td> </tr> <tr> <td>5-4</td> <td>3</td> </tr> <tr> <td>3-2</td> <td>2</td> </tr> <tr> <td>1</td> <td>1</td> </tr> <tr> <td>0</td> <td>0</td> </tr> </tbody> </table> <p>The following table shows how the marks should be awarded for structure and lines of reasoning.</p> <table border="1" data-bbox="300 994 1190 1464"> <thead> <tr> <th></th> <th>Number of marks awarded for structure of answer and sustained line of reasoning</th> </tr> </thead> <tbody> <tr> <td>Answer shows a coherent and logical structure with linkages and fully sustained lines of reasoning demonstrated throughout</td> <td>2</td> </tr> <tr> <td>Answer is partially structured with some linkages and lines of reasoning</td> <td>1</td> </tr> <tr> <td>Answer has no linkages between points and is unstructured</td> <td>0</td> </tr> </tbody> </table>	Number of indicative marking points seen in answer	Number of marks awarded for indicative marking points	6	4	5-4	3	3-2	2	1	1	0	0		Number of marks awarded for structure of answer and sustained line of reasoning	Answer shows a coherent and logical structure with linkages and fully sustained lines of reasoning demonstrated throughout	2	Answer is partially structured with some linkages and lines of reasoning	1	Answer has no linkages between points and is unstructured	0	6
Number of indicative marking points seen in answer	Number of marks awarded for indicative marking points																					
6	4																					
5-4	3																					
3-2	2																					
1	1																					
0	0																					
	Number of marks awarded for structure of answer and sustained line of reasoning																					
Answer shows a coherent and logical structure with linkages and fully sustained lines of reasoning demonstrated throughout	2																					
Answer is partially structured with some linkages and lines of reasoning	1																					
Answer has no linkages between points and is unstructured	0																					

Question number	Answer	Mark
19(c) <i>Continued</i>	<p>Indicative content</p> <ul style="list-style-type: none"> • For the yo-yo to accelerate with the train there must be a horizontal force acting on it • A horizontal force on the yo-yo is provided by the horizontal component of the tension in the string • The string could never be completely vertical because there must be a horizontal force • The yo-yo has a weight so there always has to be a vertical force acting on it • The tension in the string provides the vertical component of force • The string could never be completely horizontal because there must be a vertical force <p>Guidance on how the mark scheme should be applied: The mark for indicative content should be added to the mark for lines of reasoning. For example, an answer with five indicative marking points, which is partially structured with some linkages and lines of reasoning, scores 4 marks (3 marks for indicative content and 1 mark for partial structure and some linkages and lines of reasoning).</p> <p>If there are no linkages between points, the same five indicative marking points would yield an overall score of 3 marks (3 marks for indicative content and no marks for linkages).</p>	
	Total for Question 19	12

Write your name here

Surname

Other names

**Pearson Edexcel
International
Advanced Level**

Centre Number

--	--	--	--	--	--

Candidate Number

--	--	--	--	--	--

Physics

**International Advanced Subsidiary/Advanced Level
Unit 2: Waves and Electricity**

Sample Assessment Materials for first teaching September 2018

Time: 1 hour 30 minutes

Paper Reference

WPH12/01

You must have:

Scientific calculator, Ruler

Total Marks

--

Instructions

- Use **black** ink or **black** ball-point pen.
- **Fill in the boxes** at the top of this page with your name, centre number and candidate number.
- Answer **all** questions.
- Answer the questions in the spaces provided – *there may be more space than you need.*
- **Show all your working out in calculations and include units where appropriate.**

Information

- The total mark for this paper is 80.
- The marks for **each** question are shown in brackets – *use this as a guide as to how much time to spend on each question.*
- In questions marked with an **asterisk** (*), marks will be awarded for your ability to structure your answer logically, showing how the points that you make are related or follow on from each other where appropriate.

Advice

- Read each question carefully before you start to answer it.
- Try to answer every question.
- Check your answers if you have time at the end.

Turn over ►

S58681A

©2018 Pearson Education Ltd.

1/1/1/1/



Pearson

SECTION A

Answer ALL questions.

For questions 1–10 select one answer from A to D and put a cross in the box ☒.
If you change your mind, put a line through the box ~~☒~~ and then
mark your new answer with a cross ☒.

1 Which of the following is a unit for frequency?

- A s
- B m^{-1}
- C s^{-1}
- D m s^{-1}

(Total for Question 1 = 1 mark)

2 Which of the following properties is **not** shown by longitudinal waves?

- A diffraction
- B interference
- C polarisation
- D refraction

(Total for Question 2 = 1 mark)

DO NOT WRITE IN THIS AREA

DO NOT WRITE IN THIS AREA

DO NOT WRITE IN THIS AREA

- 3 The diagram represents the position of particles before a progressive wave passes and at a particular instant as the wave passes.

X before wave passes

X as wave passes

Which of the following graphs correctly shows the variation of pressure with distance from X as the wave passes at the instant shown?

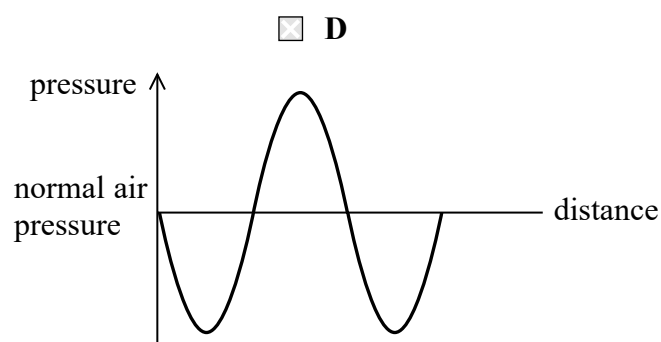
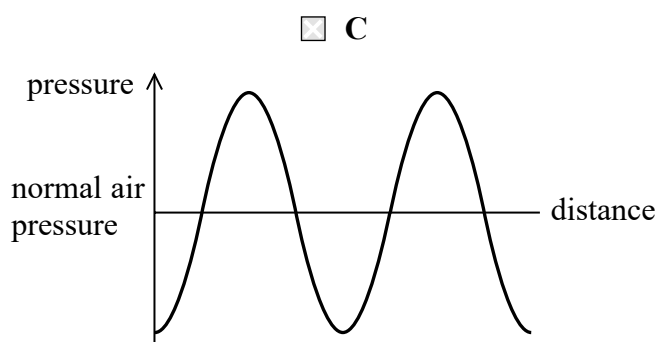
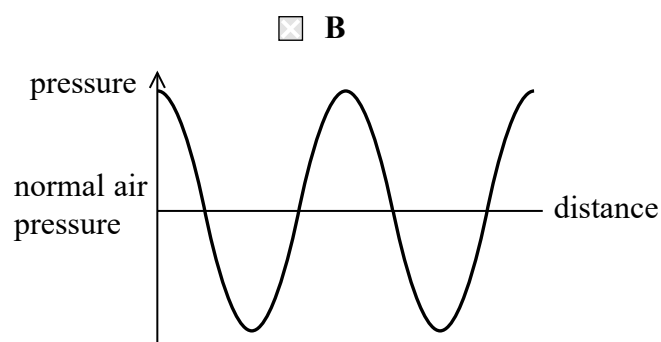
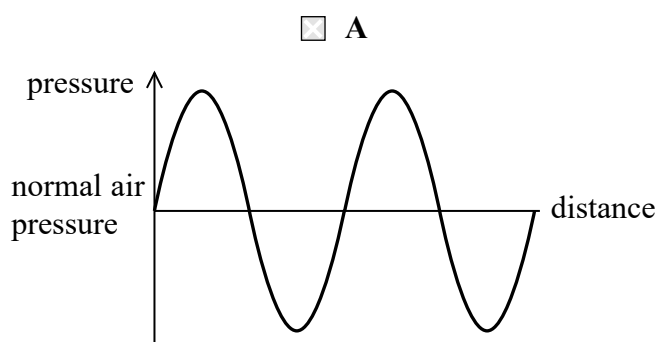

(Total for Question 3 = 1 mark)

- 4 A Slinky spring is stretched a total length l from one side of a classroom to the other. The tension in the spring is T . A wave pulse travels along the spring with a velocity v . The spring is taken to a sports hall and stretched to a total length $2l$ with tension $2T$.

Which of the following gives the velocity of the wave pulse along the spring in the sports hall?

- A $\frac{v}{\sqrt{2}}$
- B v
- C $\sqrt{2}v$
- D $2v$

(Total for Question 4 = 1 mark)

- 5 There is a potential difference of 6 V across a 4Ω resistor. A charge of 5 C flows through the resistor.

Which of the following is the energy transferred by the resistor?

- A 7.5 J
- B 20 J
- C 24 J
- D 30 J

(Total for Question 5 = 1 mark)

- 6 Which of the following will have the largest de Broglie wavelength?

- A An electron moving at almost the speed of light.
- B A proton moving at half the speed of light.
- C A tennis ball just after being hit by a tennis racket.
- D An athlete running a one hundred metre race.

(Total for Question 6 = 1 mark)

- 7 The formulae sheet contains the formula

$$I = nqvA$$

where I is the current through a sample of a material.

Which two quantities in the formula are related to the resistivity of the material?

- A n and A
- B q and v
- C n and v
- D q and A

(Total for Question 7 = 1 mark)

DO NOT WRITE IN THIS AREA

DO NOT WRITE IN THIS AREA

DO NOT WRITE IN THIS AREA

8 Which graph correctly shows how the potential difference V varies with the current I for a filament bulb?

A

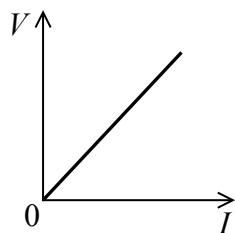

B

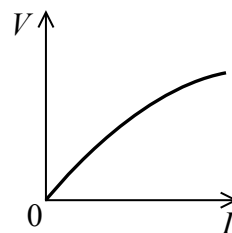

C

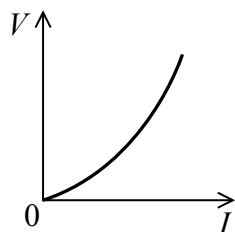

D

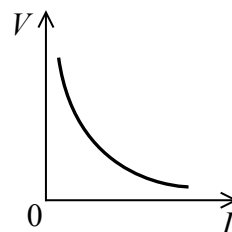

(Total for Question 8 = 1 mark)

9 Huygen's construction can be used to explain what happens to a wave when it meets an obstacle.

Which diagram is a correct attempt to use Huygen's construction to predict the position of the next wavefront?

A

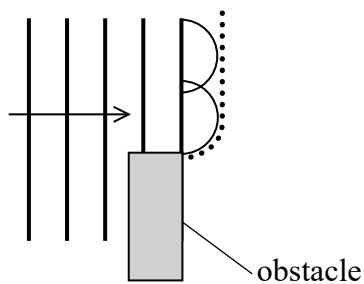

B

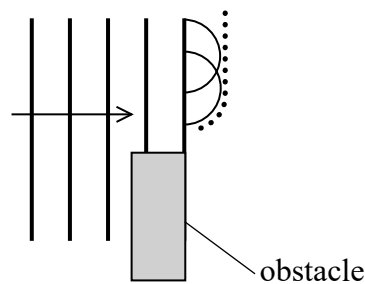

C

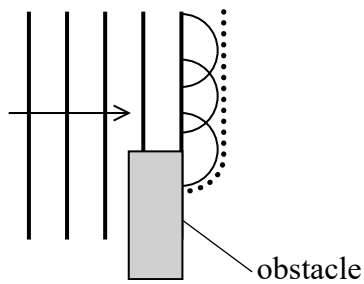

D

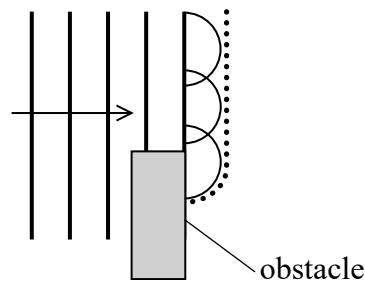

(Total for Question 9 = 1 mark)

10 Laser light of wavelength 650×10^{-9} m is directed at a diffraction lines grating.
The grating has 50 lines per mm.

A diffraction pattern appears on a screen that is 4 m from the grating.

Which expression gives the angle, in radians, between the zero order and first order fringes?

- A** $650 \times 10^{-9} \times 50$
- B** $650 \times 10^{-6} \times 50$
- C** $\sin^{-1}\left(\frac{650 \times 10^{-9}}{4}\right)$
- D** $\sin^{-1}\left(\frac{650 \times 10^{-6}}{4}\right)$

(Total for Question 10 = 1 mark)

TOTAL FOR SECTION A = 10 MARKS

DO NOT WRITE IN THIS AREA

DO NOT WRITE IN THIS AREA

DO NOT WRITE IN THIS AREA

SECTION B

Answer ALL questions.

11 An airport uses the pulse-echo technique with radio waves to monitor the positions of aeroplanes. These radio waves have a wavelength of about 0.1 m.

(a) State what is meant by wavelength.

(1)

.....

.....

(b) Determine whether a pulse of duration $1.5\mu\text{s}$ would be suitable to monitor the position of an aeroplane at a distance of 60 km from the airport.

(3)

.....

.....

.....

.....

.....

.....

DO NOT WRITE IN THIS AREA

DO NOT WRITE IN THIS AREA

DO NOT WRITE IN THIS AREA

- (c) The radio waves are emitted by a source at position X. The radio waves are reflected towards the aeroplane by a parabolic reflector that produces a beam as shown.

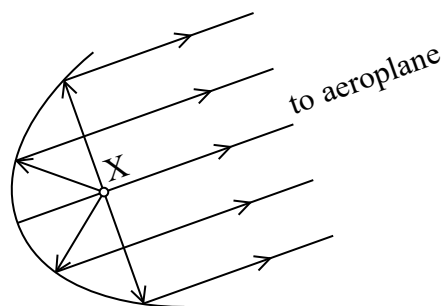

Calculate the power of the radio waves emitted by the source.

intensity of beam of radio waves = 0.16 kW m^{-2}

cross-sectional area of beam = 13.2 m^2

(2)

Power =

(Total for Question 11 = 6 marks)

DO NOT WRITE IN THIS AREA

DO NOT WRITE IN THIS AREA

DO NOT WRITE IN THIS AREA

*12 A spectrum can be produced by light from the Sun.



www.scinatech.com

Discuss why black lines appear on this spectrum.

(6)

Area with horizontal dotted lines for writing the answer.

(Total for Question 12 = 6 marks)

- 13 A teacher demonstrated standing waves using the apparatus below. The height of the reservoir can be adjusted to vary the length of the air column in the glass tube.

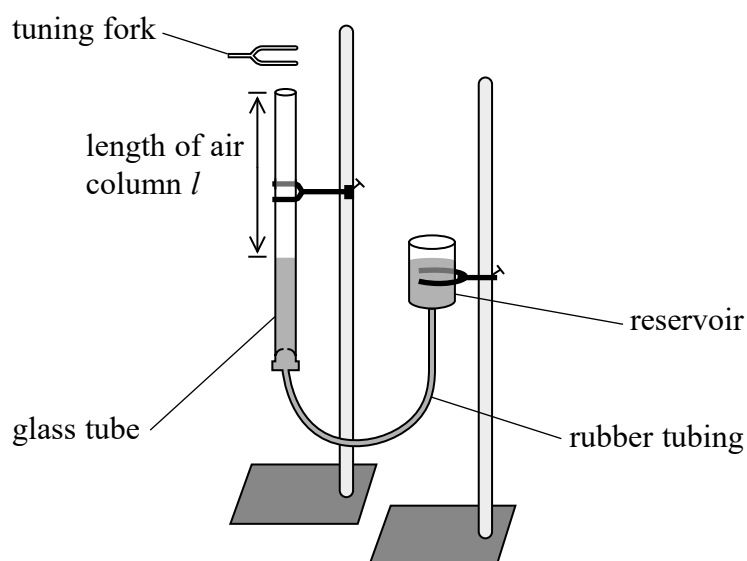

The teacher tapped a tuning fork on a table and placed it above the glass tube. He increased the length of the air column from zero until a sound was heard. At this moment a standing wave was formed in the air column, producing a sound with the same frequency as the tuning fork.

When a sound is heard, there is always a node produced at the surface of the water and an antinode at the top of the air column.

The teacher repeated this with tuning forks of different frequency f and recorded the corresponding lengths l .

- (a) State what is meant by a standing wave.

(1)

.....

.....

.....

DO NOT WRITE IN THIS AREA

DO NOT WRITE IN THIS AREA

DO NOT WRITE IN THIS AREA

(b) The teacher plotted a graph of f against $\frac{1}{l}$.

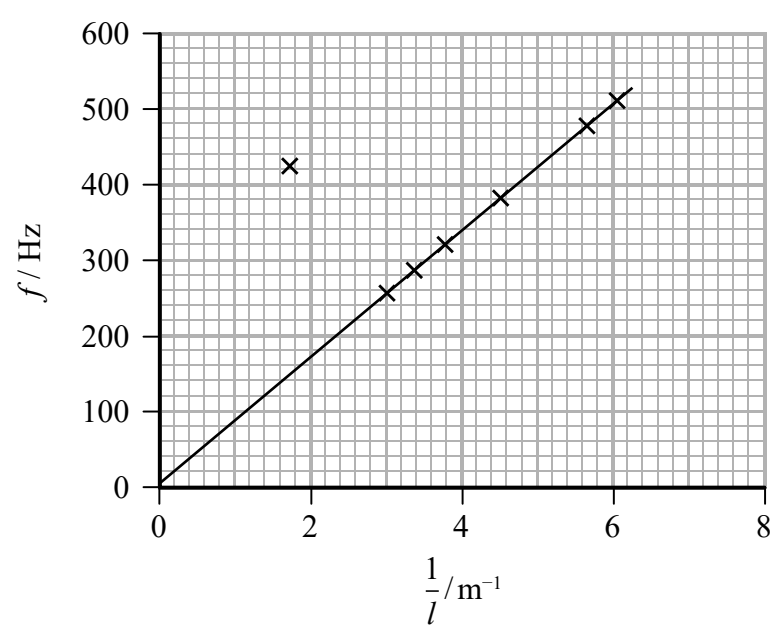

(i) Explain why the speed of sound in air is equal to $4 \times$ the gradient of this graph.

(3)

.....

.....

.....

.....

.....

.....

.....

(ii) Show that the speed of sound in air is about 300 m s^{-1} .

(2)

.....

.....

.....

.....

(iii) The teacher says that, for a tuning fork of a particular frequency, sounds will be heard for different lengths of the air column.

One point plotted on the graph does not lie on the line of best fit.

Deduce whether this point is an anomaly or whether it corresponds to an audible sound.

(3)

.....

.....

.....

.....

.....

.....

.....

(Total for Question 13 = 9 marks)

DO NOT WRITE IN THIS AREA

DO NOT WRITE IN THIS AREA

DO NOT WRITE IN THIS AREA

DO NOT WRITE IN THIS AREA

DO NOT WRITE IN THIS AREA

DO NOT WRITE IN THIS AREA

14 A light dependent resistor (LDR) has a resistance of $6100\ \Omega$ when illuminated with indoor lighting.

(a) Explain how the resistance of an LDR changes with illumination. Your answer should include reference to conduction electrons.

(2)

.....

.....

.....

.....

.....

(b) A student made an electrical cell using a lemon, a piece of zinc and a piece of copper as shown.



© Science Photo Library

The student connected a digital voltmeter to the cell and recorded an electromotive force (e.m.f.) of 0.97 V.

She then connected the LDR to the cell and recorded a reading from the digital voltmeter of 0.47 V.

(i) Define e.m.f.

(1)

.....

.....

(ii) Calculate the internal resistance of the cell.

resistance of LDR = $6100\ \Omega$

(3)

Internal resistance =

(iii) Calculate the power transferred by the LDR.

(2)

Power transferred =

(Total for Question 14 = 8 marks)

DO NOT WRITE IN THIS AREA

DO NOT WRITE IN THIS AREA

DO NOT WRITE IN THIS AREA

DO NOT WRITE IN THIS AREA

DO NOT WRITE IN THIS AREA

DO NOT WRITE IN THIS AREA

15 Some observatories are looking for evidence of planets orbiting stars.

Detecting a planet is difficult because its reflected light is insignificant compared to the light emitted by the star.

A technique known as “nulling interferometry” is being developed. It relies on the property of interference produced by the superposition of two beams of coherent light.

- (a) Beams of light from the star and from the planet are collected by telescopes T_1 and T_2 . The beams are superimposed using a beam combiner as shown.

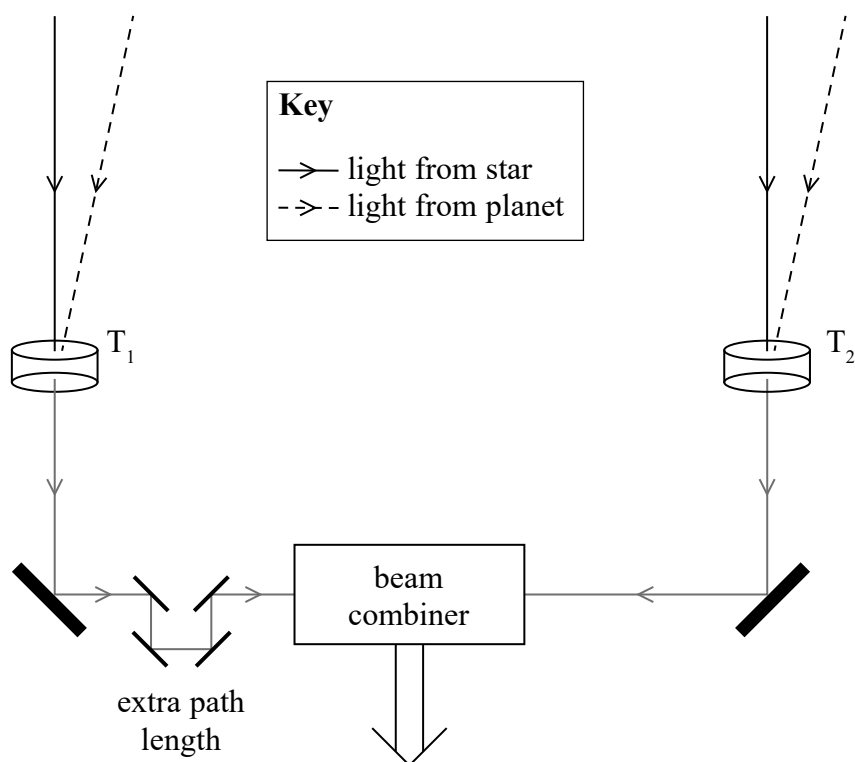

Light from the star would arrive at both telescopes having travelled equal distances. A system of mirrors is used to increase the path length of one of the beams by an extra path length, equal to half the wavelength of the light.

(i) Explain what happens when the two beams of light from the star are combined.

(2)

.....

.....

.....

.....

.....

(ii) The two beams of light from the planet arrive at the telescopes at a slight angle so these beams have travelled different distances. Explain the condition that would result in this light combining to reveal the planet.

(2)

.....

.....

.....

.....

(b) At present, nulling interferometry has been demonstrated in laboratories using infrared radiation.

Explain why it will be more difficult to demonstrate the effect with visible light from stars.

(2)

.....

.....

.....

.....

.....

(Total for Question 15 = 6 marks)

DO NOT WRITE IN THIS AREA

DO NOT WRITE IN THIS AREA

DO NOT WRITE IN THIS AREA

DO NOT WRITE IN THIS AREA

DO NOT WRITE IN THIS AREA

DO NOT WRITE IN THIS AREA

16 Sensors that monitor the moisture in soil can be useful to farmers.

The sensor includes two probes as shown in the photograph. The probes are pushed into the soil.

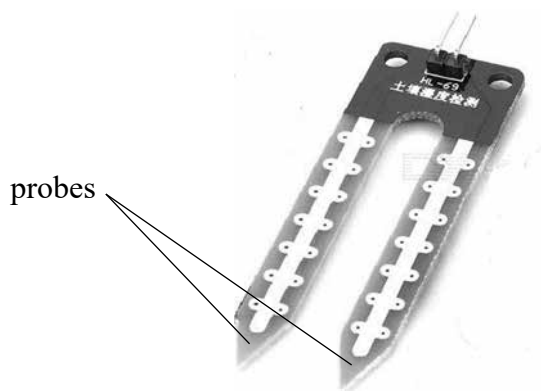

Source from: <http://www.dx.com/p/produino-lm393-3-3-5v-soil-hygrometer-detection-module-soil-moisture-sensor-for-arduino-blue-290154#.WQhcuPkrKUK>

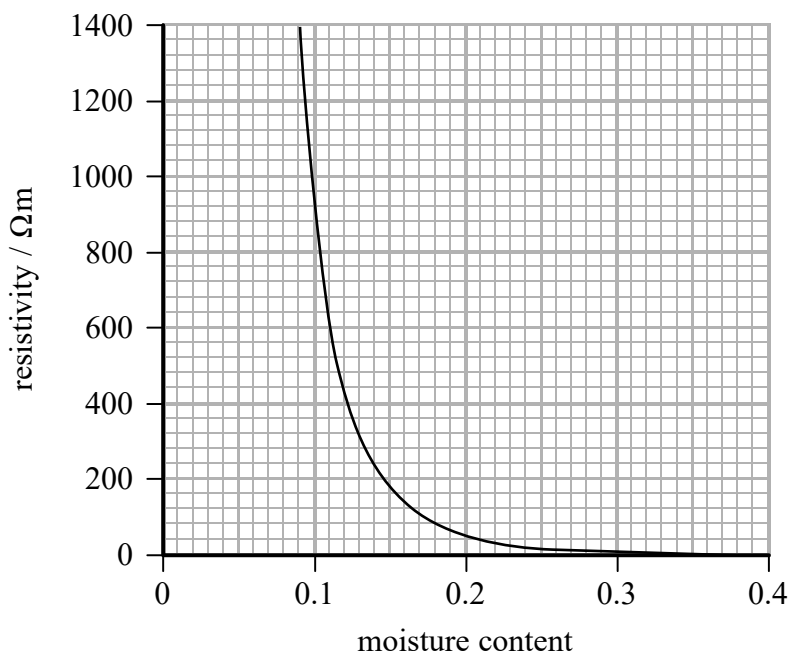

The graph shows how the resistivity of soil varies with moisture content measured as a fraction of the volume of soil.

- (a) Show that the resistance of the soil between the two probes is about $21\text{ k}\Omega$ when the moisture content is 0.14

length of soil between probes = 5.0 cm

effective cross-sectional area of soil between probes = 5.8 cm^2

(3)

.....

.....

.....

.....

.....

- (b) The sensor consists of a circuit that includes the probes and provides an output potential difference (p.d.) as shown. The output p.d. can be used to switch on a water supply.

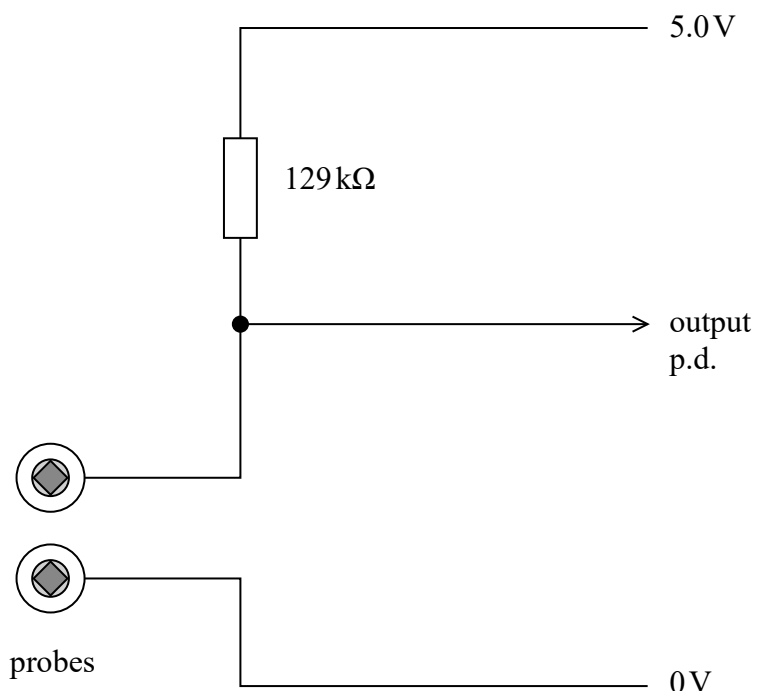

- (i) Calculate the output p.d. when the resistance of the soil between the probes is $21\text{ k}\Omega$ (2)

Output p.d. =

(ii) A farmer finds the following notes about the sensor on the internet.

If the output p.d. falls below 0.7 V then this indicates that the soil has a moisture content of less than 0.14 and the water supply is switched on to make the soil wetter.

Discuss whether this information is correct.

(4)

.....

.....

.....

.....

.....

.....

.....

.....

(c) A different sensor can be produced by replacing the probes with a negative temperature coefficient thermistor.

Explain what this sensor circuit could be used for.

(3)

.....

.....

.....

.....

.....

.....

.....

.....

(Total for Question 16 = 12 marks)

DO NOT WRITE IN THIS AREA

DO NOT WRITE IN THIS AREA

DO NOT WRITE IN THIS AREA

- 17 A gold leaf electroscope is used to detect very small amounts of charge. The diagram shows an uncharged gold leaf electroscope.

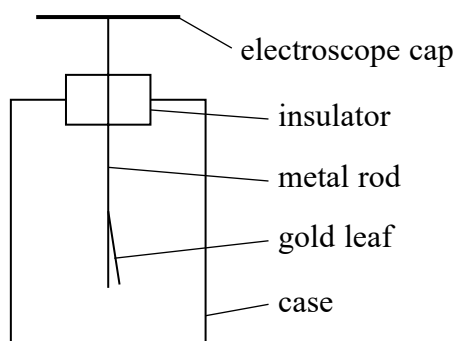

When the electroscope cap is given a negative charge, electrons spread along the metal rod and the gold leaf so they both become negatively charged. The rod and leaf repel each other, so the gold leaf rises up as shown below.

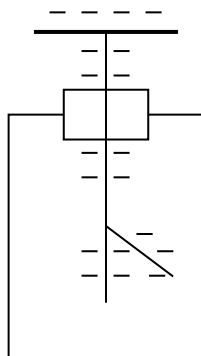

A gold leaf electroscope can be used to demonstrate the photoelectric effect. A clean zinc plate is placed onto the cap of the electroscope and the plate and electroscope are given a negative charge. Ultraviolet radiation is shone onto the zinc plate and the gold leaf slowly falls.

- (a) Explain why the gold leaf falls.

(3)

- (b) Zinc has a work function of 4.3 eV. Calculate the maximum wavelength of light that will produce the photoelectric effect with zinc.

(3)

.....

.....

.....

.....

.....

.....

Maximum wavelength =

- (c) The electroscope is charged again. The ultraviolet radiation is replaced by a high intensity source of infrared radiation and the demonstration is repeated. The gold leaf does not fall.

Explain why the wave nature of electromagnetic radiation cannot be used to explain this observation.

(3)

.....

.....

.....

.....

.....

.....

.....

.....

.....

(Total for Question 17 = 9 marks)

18 The concentration of sugar in fruit juice can be determined using a refractometer. A simple refractometer consists of a 45° prism made of glass.

(a) Calculate the speed of light in glass.

refractive index of glass = 1.52

(2)

.....

.....

.....

Speed of light in glass =

(b) The diagram shows the path of a beam of light travelling from a light source in air through a 45° glass prism. The path taken by the beam of light is shaded. The critical angle for glass is 41° .

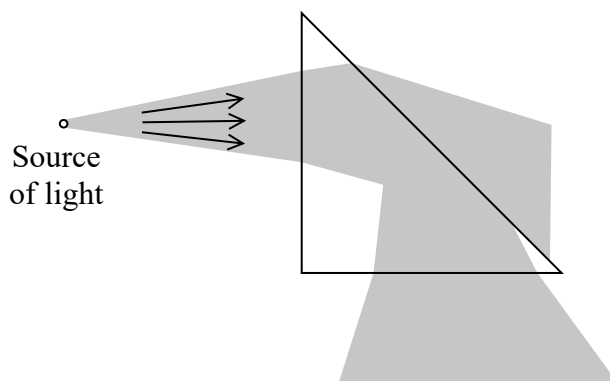

Explain the path of the beam of light.

(4)

.....

.....

.....

.....

.....

.....

.....

.....

.....

.....

- (c) A sample of fruit juice is placed on the prism. The initial path of the beam of light is shown. Some of the transmitted light falls onto a scale.

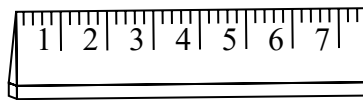
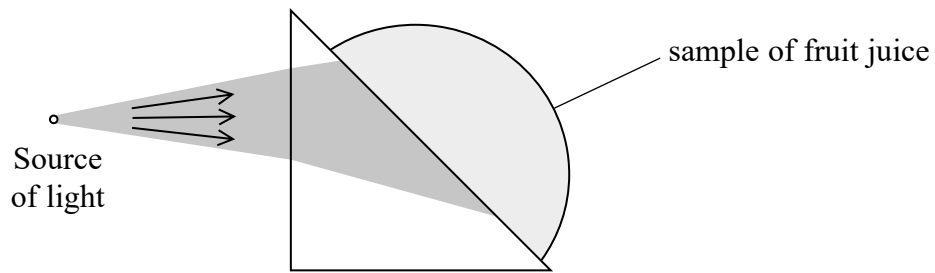

scale

- (i) Show that the critical angle for light passing from the glass to the fruit juice is about 59° .

refractive index of fruit juice = 1.30

(2)

- (ii) Add to the diagram to complete the path of the beam of light.

(3)

(iii) Juice containing a higher concentration of sugar will have a greater refractive index.

Explain how the length of the scale that is illuminated will change if this fruit juice is replaced with a sample containing a higher concentration of sugar.

(3)

.....

.....

.....

.....

.....

.....

.....

(Total for Question 18 = 14 marks)

TOTAL FOR SECTION B = 70 MARKS

TOTAL FOR PAPER = 80 MARKS

Every effort has been made to contact copyright holders to obtain their permission for the use of copyright material. Pearson Education Ltd. will, if notified, be happy to rectify any errors or omissions and include any such rectifications in future editions.

DO NOT WRITE IN THIS AREA

DO NOT WRITE IN THIS AREA

DO NOT WRITE IN THIS AREA

Unit 2: Waves and Electricity - Mark scheme

Question number	Answer	Mark
1	C	1
2	C	1
3	B	1
4	D	1
5	D	1
6	A	1
7	C	1
8	C	1
9	C	1
10	B	1

Question number	Answer	Mark
11(a)	Wavelength is the distance between two adjacent points that are in phase (1)	1
11(b)	<ul style="list-style-type: none"> • Use of $v = s/t$ (1) • Calculate distance to aircraft when the return time is $0.75 \mu\text{s}$ (225 m) Or Calculate time for pulse to return when distance to aircraft is 60 km (2.3×10^{-4} s) Or Calculate total distance travelled by pulse when the return time is $1.5 \mu\text{s}$ (225 m) and compare to 60 km Or Calculate time for pulse to return when distance travelled is 60 km (2.0×10^{-4} s) and compare to $0.75 \mu\text{s}$ (1) • Appropriate comment on suitability, e.g. detectable distance less than distance required, so suitable Or pulse shorter than time required to travel the distance, so suitable (Third mark is awarded only if second mark is awarded) (1) <p><u>Example of calculation</u> $s = 3 \times 10^8 \text{ m s}^{-1} \times 1.5 \times 10^{-6} \text{ s}$ $s = 450 \text{ m}$ One way = 225 m Or $t = 60000 \text{ m} / 3 \times 10^8 \text{ m s}^{-1}$ $t = 2.0 \times 10^{-4} \text{ s}$</p>	3

Question number	Answer	Mark
11(c)	<ul style="list-style-type: none"> • Use of $I = \frac{P}{A}$ (1) • $P = 2.1 \text{ kW}$ (1) <p>Example of calculation $P = 0.16 \text{ kWm}^{-2} \times 13.2 \text{ m}^2$</p>	2
	Total for Question 11	6

Question number	Answer	Mark																				
12	<p>This question assesses a student’s ability to show a coherent and logically structured answer with linkages and fully-sustained reasoning. Marks are awarded for indicative content and for how the answer is structured and shows lines of reasoning. The following table shows how the marks should be awarded for indicative content.</p> <table border="1" data-bbox="279 371 740 685"> <thead> <tr> <th>Number of indicative marking points seen in answer</th> <th>Number of marks awarded for indicative marking points</th> </tr> </thead> <tbody> <tr> <td>6</td> <td>4</td> </tr> <tr> <td>5–4</td> <td>3</td> </tr> <tr> <td>3–2</td> <td>2</td> </tr> <tr> <td>1</td> <td>1</td> </tr> <tr> <td>0</td> <td>0</td> </tr> </tbody> </table> <p>The following table shows how the marks should be awarded for structure and lines of reasoning.</p> <table border="1" data-bbox="279 792 1286 1202"> <thead> <tr> <th></th> <th>Number of marks awarded for structure of answer and sustained line of reasoning</th> </tr> </thead> <tbody> <tr> <td>Answer shows a coherent and logical structure with linkages and fully sustained lines of reasoning demonstrated throughout</td> <td>2</td> </tr> <tr> <td>Answer is partially structured with some linkages and lines of reasoning</td> <td>1</td> </tr> <tr> <td>Answer has no linkages between points and is unstructured</td> <td>0</td> </tr> </tbody> </table> <p>Total marks awarded is the sum of marks for indicative content and the marks for structure and lines of reasoning</p> <p>Indicative content</p> <ul style="list-style-type: none"> • (the atoms) of gases in the atmosphere contain electrons • electrons absorb photons from the sunlight • electron moves to higher energy level • the energy levels (of electrons) are discrete Or only certain energy levels are possible • The energy of the photon must be equal to the difference in energy levels Or $hf = E_2 - E_1$ • There are only a limited number of energy differences and only a corresponding number of black lines 	Number of indicative marking points seen in answer	Number of marks awarded for indicative marking points	6	4	5–4	3	3–2	2	1	1	0	0		Number of marks awarded for structure of answer and sustained line of reasoning	Answer shows a coherent and logical structure with linkages and fully sustained lines of reasoning demonstrated throughout	2	Answer is partially structured with some linkages and lines of reasoning	1	Answer has no linkages between points and is unstructured	0	6
Number of indicative marking points seen in answer	Number of marks awarded for indicative marking points																					
6	4																					
5–4	3																					
3–2	2																					
1	1																					
0	0																					
	Number of marks awarded for structure of answer and sustained line of reasoning																					
Answer shows a coherent and logical structure with linkages and fully sustained lines of reasoning demonstrated throughout	2																					
Answer is partially structured with some linkages and lines of reasoning	1																					
Answer has no linkages between points and is unstructured	0																					
	Total for Question 12	6																				

Question number	Answer	Mark
13(a)	<ul style="list-style-type: none"> A wave on which there are points that always have maximum displacement and others that always have zero displacement Or A wave on which there are points that are nodes and antinodes 	1
13(b)(i)	<ul style="list-style-type: none"> Quarter of a wavelength in length of air/pipe Use of $v = f\lambda$ Comparison with $y = mx$ <p><u>Example of calculation</u> $v = f \times 4l$ $f = \frac{v}{4} \times \frac{1}{l}$</p>	3
13(b)(ii)	<ul style="list-style-type: none"> Determines gradient of graph $v = 330 \text{ (m s}^{-1}\text{)}$ <p><u>Example of calculation</u> Gradient = $\frac{500\text{s}^{-1}}{6\text{m}^{-1}} = 83.3 \text{ m s}^{-1}$ $v = 4 \times 83.3 = 330 \text{ m s}^{-1}$</p>	2
13(b)(iii)	<ul style="list-style-type: none"> Use of $v = f\lambda$ to determine λ Second standing wave: length = $\frac{3}{4}$ wavelength Corresponds to $1/l = 1.7 \text{ (m}^{-1}\text{)}$ as given on the graph so yes produced audible sound <p><u>Example of calculation</u> $330 = 415\lambda$ $\lambda = 0.795\text{m}$ $l = \frac{3}{4} \times 0.795$ $l = 0.6\text{m}$ $\frac{1}{l} = 1.7\text{m}^{-1}$</p>	3
Total for Question 13		9

Question number	Answer	Mark
14(a)	<ul style="list-style-type: none"> Light (photons) transfers energy to electrons (1) Greater number of conduction electrons so less resistance (1) 	2
14(b)(i)	<ul style="list-style-type: none"> Amount of energy supplied (by the cell) per unit charge (1) 	1
14(b)(ii)	<ul style="list-style-type: none"> Use of $V = IR$ to calculate current (1) Subtraction of p.d. from e.m.f. (1) $r = 6500 \Omega$ (1) <p><u>Example of calculation</u></p> $I = \frac{0.47}{6100} = 7.7 \times 10^{-5} \text{ A}$ $r = \frac{0.97 - 0.47}{7.7 \times 10^{-5}} = 6500 \Omega$	3
14(b)(iii)	<ul style="list-style-type: none"> Use of $P = VI$ (1) Or $P = V^2/R$ (1) $P = 3.6 \times 10^{-5} \text{ W}$ (1) <p><u>Example of calculation</u></p> $P = 7.7 \times 10^{-5} \text{ A} \times 0.47 \text{ V} = 3.6 \times 10^{-5} \text{ W}$	2
Total for Question 14		8

Question number	Answer	Mark
15(a)(i)	<ul style="list-style-type: none"> A minimum is produced (1) Waves arrive 180° out of phase (1) 	2
15(a)(ii)	<ul style="list-style-type: none"> If this path difference = half a wavelength then a maximum would occur, as the overall path difference = one wavelength (1) So the light from the planet produces a maximum and the light from the star produces a minimum (1) 	2
15(b)	<ul style="list-style-type: none"> IR radiation has a longer wavelength than visible light (1) In a laboratory the setup can be made to have a path difference that matches half the wavelength of IR used Or the actual path difference with visible light would be extremely small (1) 	2
Total for Question 15		6

Question number	Answer	Mark
16(a)	<ul style="list-style-type: none"> • Uses graph to find $\rho = 240 \text{ Wm}$ (1) • Use of $R = \frac{\rho l}{A}$ (1) • $R = 21 \text{ k}\Omega$ (1) <p><u>Example of calculation:</u></p> $R = \frac{240 \text{ Wm} \times 5.0 \times 10^{-2} \text{ m}}{5.8 \times 10^{-4} \text{ m}^2} = 20.7 \text{ k}\Omega$	3
16(b)(i)	<ul style="list-style-type: none"> • Use of $I = V/R$ (1) • Output p.d. = 0.70 V (1) <p><u>Example of calculation:</u></p> $V = \frac{21}{21+129} \times 5 = 0.70 \text{ V}$	2
16(b)(ii)	<p>Either</p> <ul style="list-style-type: none"> • As soil dries resistivity of soil increases (1) • As soil dries R_{probe} increases (above 21k) (1) • So as soil dries the p.d. becomes greater than 0.7 V (1) • Incorrect information as this system will switch off water as soil gets drier (1) <p>Or</p> <ul style="list-style-type: none"> • As soil gets wetter resistivity decreases (1) • As soil has moisture more than 0.14 R_{probe} decreases (below 21 k) (1) • As it gets wetter p.d. decreases below 0.7 V (1) • Incorrect information as this system will switch on water as soil gets wetter (1) 	4
16(c)	<ul style="list-style-type: none"> • Negative coefficient: resistance decreases as temperature increases (1) • Resistance decreases means output p.d. decreases (1) • So sensor could switch on coolers • Or open windows • Or turn off heaters • when temperature above a certain value (1) 	3
	Total for Question 16	12

Question number	Answer	Mark	
17(a)	<ul style="list-style-type: none"> Photons of ultraviolet light Results in electrons being emitted from <u>surface</u> of zinc So electroscopes lose charge and leaf falls 	(1) (1) (1)	3
17(b)	<ul style="list-style-type: none"> Use of $\phi = hf$ Use of $c = f\lambda$ $\lambda = 2.9 \times 10^{-7} \text{ m}$ <p><u>Example of calculation</u></p> $4.3 \times 1.6 \times 10^{-19} \text{ J} = 6.63 \times 10^{-34} \text{ J s} \times f$ $f = 1.04 \times 10^{15} \text{ Hz}$ $3.00 \times 10^8 \text{ m s}^{-1} = 1.04 \times 10^{15} \text{ Hz} \times \lambda$ $\lambda = 2.9 \times 10^{-7} \text{ m}$	(1) (1) (1)	3
17(c)	<ul style="list-style-type: none"> Wave energy depends on intensity Energy is spread over the whole wave The wave model suggests that if exposed for long enough electrons would eventually be released but this does not happen. 	(1) (1) (1)	3
Total for Question 17			9

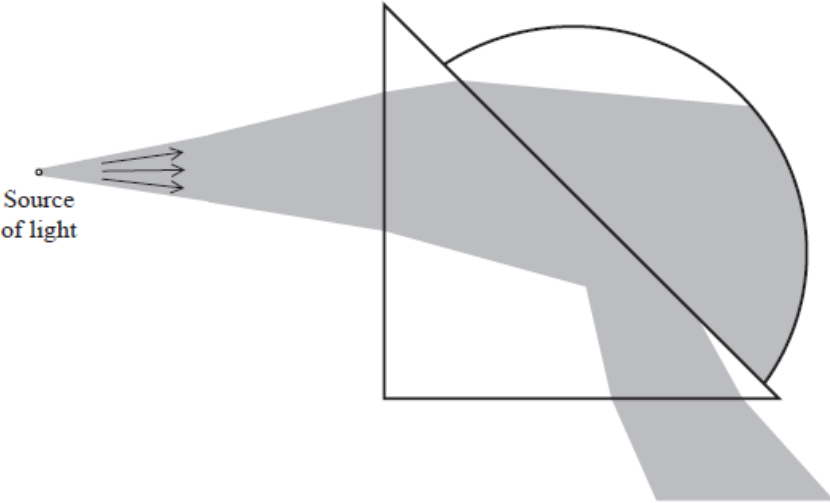
Question number	Answer	Mark
18(a)	<ul style="list-style-type: none"> • Use of $n = \frac{c}{v}$ (1) • $v = 1.97 \times 10^8 \text{ m s}^{-1}$ (1) <p><u>Example of calculation</u></p> $1.52 = \frac{3.00 \times 10^8}{v}$ $v = 1.97 \times 10^8 \text{ m s}^{-1}$	2
18(b)	<ul style="list-style-type: none"> • At the first surface the beam refracts towards the normal (1) • At the second surface some of the beam is incident at an angle greater than c – this light internally reflects (1) • Some of the light is less than c this refracts out of the prism (1) • At the bottom surface the light refracts out of the prism (1) 	4
18(c)(i)	<ul style="list-style-type: none"> • Use of $n_1 \sin \theta_1 = n_2 \sin \theta_2$ (1) • $C = 58.8^\circ$ (1) <p><u>Example of calculation</u></p> $1.52 \times \sin C = 1.30 \times \sin 90^\circ$ $C = 58.8^\circ$	2
18(c)(ii)	<ul style="list-style-type: none"> • The beam has a larger angle of deviation when it is refracted into the air than when it is refracted into the fruit juice (1) • Very small proportion of beam reflecting at second surface (1) • Some refraction shown on leaving bottom surface (1) <p><u>Example of diagram</u></p> 	3

Question number	Answer	Mark
18(c)(iii)	<ul style="list-style-type: none"> • If refractive index greater then critical angle greater (1) • So less of beam reflected at second surface (1) • Hence the illumination of the scale is over a shorter length (1) <p>(MP3 dependent on MP2)</p>	3
	Total for Question 18	14

Write your name here

Surname

Other names

**Pearson Edexcel
International
Advanced Level**

Centre Number

--	--	--	--	--	--

Candidate Number

--	--	--	--	--

Physics

**International Advanced Subsidiary/Advanced Level
Unit 3: Practical Skills in Physics I**

Sample Assessment Materials for first teaching September 2018

Time: 1 hour 20 minutes

Paper Reference

WPH13/01

You must have:

Scientific calculator, Ruler

Total Marks

Instructions

- Use **black** ink or **black** ball-point pen.
- **Fill in the boxes** at the top of this page with your name, centre number and candidate number.
- Answer **all** questions.
- Answer the questions in the spaces provided – *there may be more space than you need.*
- **Show all your working in calculations** with **your answer clearly identified** at the **end of your solution.**

Information

- The total mark for this paper is 50.
- The marks for **each** question are shown in brackets – *use this as a guide as to how much time to spend on each question.*

Advice

- Read each question carefully before you start to answer it.
- Try to answer every question.
- Check your answers if you have time at the end.

Turn over ►

S58682A

©2018 Pearson Education Ltd.

1/1/1



Pearson

Answer ALL questions.

1 A student uses a graphical method to determine the resistivity of a material in the form of a wire.

(a) State three advantages of using a graphical method.

(3)

.....

.....

.....

.....

.....

.....

(b) The student measures the diameter of the wire using a micrometer screw gauge.

Explain a technique that the student should use to make this measurement as accurate as possible.

(3)

.....

.....

.....

.....

.....

.....

.....

.....

.....

(Total for Question 1 = 6 marks)

DO NOT WRITE IN THIS AREA

DO NOT WRITE IN THIS AREA

DO NOT WRITE IN THIS AREA

DO NOT WRITE IN THIS AREA

DO NOT WRITE IN THIS AREA

DO NOT WRITE IN THIS AREA

- 2 A student determines the density of a metal in the form of a cylinder.
- (a) The student uses Vernier calipers to measure the diameter of the cylinder. The reading she obtains is 24.0 mm.

Calculate the percentage uncertainty in the measurement of the diameter. (2)

.....

.....

.....

Percentage uncertainty in measurement of diameter =

- (b) The length of the cylinder is approximately 160 mm.
- (i) State a suitable instrument for measuring the length. (1)

.....

- (ii) The student records the following readings for the length.

158 mm 159 mm 161 mm 162 mm

Calculate the percentage uncertainty in the measurement of the length. (2)

.....

.....

Percentage uncertainty in measurement of length =

(c) The mass of the cylinder is 0.616 kg.

Calculate the density of the metal.

(4)

.....

.....

.....

.....

.....

Density =

(Total for Question 2 = 9 marks)

DO NOT WRITE IN THIS AREA

DO NOT WRITE IN THIS AREA

DO NOT WRITE IN THIS AREA

DO NOT WRITE IN THIS AREA

DO NOT WRITE IN THIS AREA

DO NOT WRITE IN THIS AREA

(d) Comment on any safety issues associated with this experiment.

(1)

.....

.....

(e) Explain how you would use the graph to determine the resistance of the diode at a given potential difference.

(2)

.....

.....

.....

.....

(Total for Question 3 = 13 marks)

DO NOT WRITE IN THIS AREA

DO NOT WRITE IN THIS AREA

DO NOT WRITE IN THIS AREA

4 A student determined the refractive index of glass by shining a ray of light on to a rectangular glass block as shown.

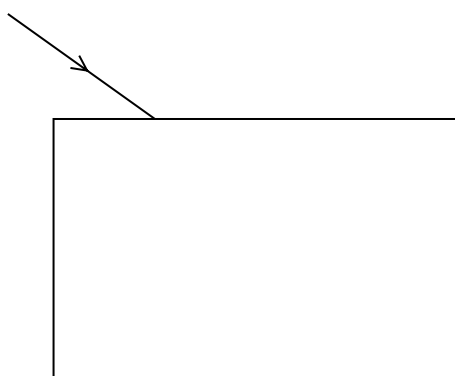

(a) The ray is refracted and emerges from the opposite side of the glass block.

Add to the diagram to show how the ray of light will pass through the glass block and emerge from the opposite side.

(2)

(b) Describe how the student should accurately determine the path of the ray through the glass block.

(2)

.....

.....

.....

.....

.....

.....

- (c) The student measured the angle of incidence i and the corresponding angle of refraction r for the ray. He repeated the procedure several times for different values of i . His measurements and his values of $\sin i$ are recorded in the table below.

$i / ^\circ$	$r / ^\circ$	$\sin i$	$\sin r$
10	5	0.17	
20	12	0.34	
30	18	0.50	
35	21	0.57	

- (i) Criticise these measurements.

(2)

.....

.....

.....

.....

- (ii) Use the data in the table to plot a graph of $\sin i$ on the y -axis against $\sin r$ on the x -axis on the grid provided. Use the right-hand column for your processed data.

(6)

DO NOT WRITE IN THIS AREA

DO NOT WRITE IN THIS AREA

DO NOT WRITE IN THIS AREA

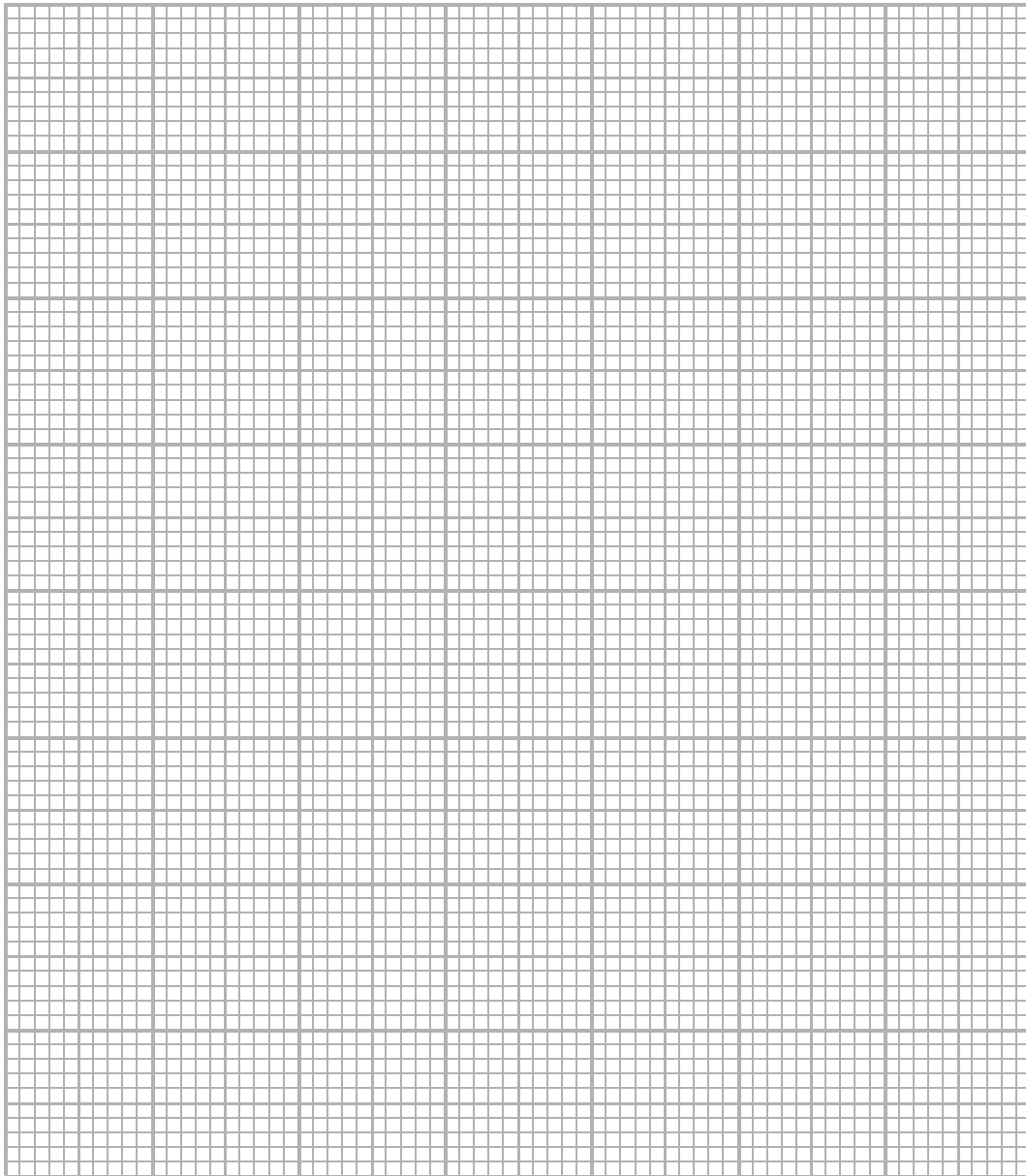

(iii) Use your graph to determine the refractive index of the glass.

(3)

.....

.....

.....

.....

.....

.....

Refractive index of glass =

(Total for Question 4 = 15 marks)

DO NOT WRITE IN THIS AREA

DO NOT WRITE IN THIS AREA

DO NOT WRITE IN THIS AREA

DO NOT WRITE IN THIS AREA

DO NOT WRITE IN THIS AREA

DO NOT WRITE IN THIS AREA

5 A student carried out an experiment to determine the viscosity η of a liquid. She dropped a sphere through a column of liquid and obtained the following results.

Diameter of sphere d	3.1 mm
Density of sphere ρ_s	8500 kg m^{-3}
Density of liquid ρ_l	1260 kg m^{-3}
Terminal velocity v of sphere	0.038 m s^{-1}

(a) Use the equation given below to calculate η , where r is the radius of the sphere.

$$v = \frac{2r^2(\rho_s - \rho_l)g}{9\eta} \tag{4}$$

.....

.....

.....

.....

.....

.....

.....

.....

.....

.....

$\eta =$

(b) Suggest three experimental techniques the student could have used to obtain accurate results.

(3)

.....

.....

.....

.....

.....

.....

.....

(Total for Question 5 = 7 marks)

TOTAL FOR PAPER = 50 MARKS

DO NOT WRITE IN THIS AREA

DO NOT WRITE IN THIS AREA

DO NOT WRITE IN THIS AREA

Unit 3: Practical Skills in Physics I - Mark scheme

Question number	Answer	Mark
1(a)	<ul style="list-style-type: none"> Line of best fit minimises the effects of random errors (1) Or line of best fit ‘averages’ results (1) Anomalous readings can be identified (1) Systematic errors can be detected (1) 	3
1(b)	<ul style="list-style-type: none"> Take readings at different positions/orientations along the wire (1) as the wire may not be uniform (1) and calculate a mean (1) 	3
Total for Question 1		6

Question number	Answer	Mark
2(a)	<ul style="list-style-type: none"> Use of half resolution (0.05 mm) (1) Percentage uncertainty = 0.2% (Accept 0.21%) (1) <p><u>Example of calculation</u> Uncertainty = $(0.05/24) \times 100 = 0.208 \%$</p>	2
2(b)(i)	Metre rule (1)	1
2(b)(ii)	<ul style="list-style-type: none"> Use of half range (2 mm) (1) Percentage uncertainty = 1% (Accept 1.3%) (1) <p><u>Example of calculation</u> Uncertainty = $(2/160) \times 100 = 1.25 \%$</p>	2
2(c)	<ul style="list-style-type: none"> Use of volume = length $\times \pi d^2/4$ ($7.24 \times 10^{-5} \text{ m}^3$) (1) Use of density = mass/volume (1) Density = 8500 kg m^{-3} (1) to 2 or 3 sig figs (1) <p><u>Example of calculation</u> Volume = $0.160 \text{ m} \times 3.14 \times (0.024 \text{ m})^2/4$ Volume = $7.24 \times 10^{-5} \text{ m}^3$ Density = mass/volume = $0.616 \text{ kg} / 7.24 \times 10^{-5} \text{ m}^3$ Density = 8510 kg m^{-3}</p>	4
Total for Question 2		9

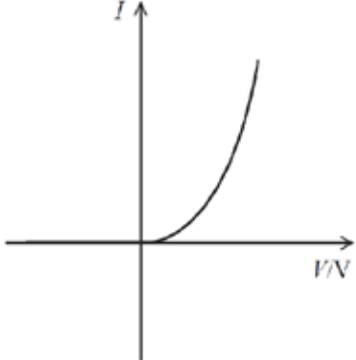
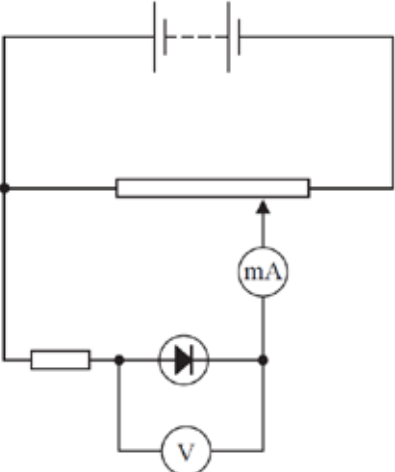
Question number	Answer	Mark
3(a)	<ul style="list-style-type: none"> • Reverse bias: zero current (1) • Forward bias: zero current for small values of p.d. then current increasing rapidly (1) <p><u>Example of graph</u></p> 	2
3(b)	<ul style="list-style-type: none"> • Correct potential divider circuit with diode and fixed resistor (1) • Voltmeter in parallel with diode (1) • Ammeter in series with diode (1) <p>Experimental procedure</p> <ul style="list-style-type: none"> • Record current for varying p.d.s. (1) • Reverse terminals for reverse bias (1) • Take extra readings at small intervals when the diode begins conducting for the sharp part of the curve (1) <p><u>Example of circuit</u></p> 	6
3(c)	<ul style="list-style-type: none"> • The temperature of the diode may increase distorting the readings of current (1) • The readings on the meters may fluctuate (1) 	2
3(d)	<ul style="list-style-type: none"> • Comment on level of risk and associated justification (1) <p><u>Examples of answer</u> This is a low-risk experiment as it uses a 12 V power supply Or diode may explode so goggles should be worn</p>	1

Question number	Answer	Mark
3(e)	<ul style="list-style-type: none"> Use the graph to read the value of current at the given p.d. (1) Use $R = V/I$ to calculate resistance (1) 	2
Total for Question 3		13

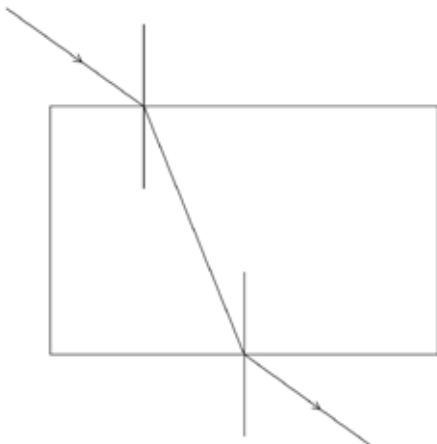
Question number	Answer	Mark
4(a)	<ul style="list-style-type: none"> Refraction towards the normal at the first boundary and refraction away from the normal at the second boundary (1) Emerging ray parallel to the incident ray (1) 	2
4(b)	<ul style="list-style-type: none"> Place block on white paper, trace round it and draw points on incident and emergent rays (1) Remove block, join up points and draw ray within block using a ruler (1) 	2
4(c)(i)	<p>Any 2 from</p> <ul style="list-style-type: none"> Too few sets of results Or only 4 sets of results (1) Range of values of i are too small (1) No evidence of use of readings as ray leaves the block (1) 	2

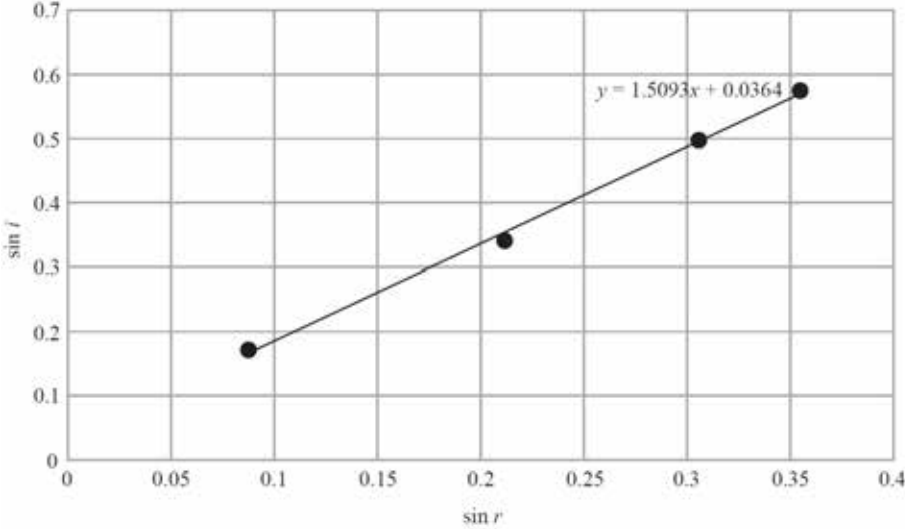
Question number	Answer	Mark																					
4(c)(ii)	<ul style="list-style-type: none"> • Correct $\sin r$ values to two s.f. • Labels on axes with $\sin i$ along the y-axis • Sensible scales • Plotting • Line of best fit <table border="1" style="margin: 10px auto;"> <thead> <tr> <th>$i / ^\circ$</th> <th>$r / ^\circ$</th> <th>$\sin i$</th> <th>$\sin r$</th> </tr> </thead> <tbody> <tr> <td>10</td> <td>5</td> <td>0.17</td> <td>0.087</td> </tr> <tr> <td>20</td> <td>12</td> <td>0.34</td> <td>0.21</td> </tr> <tr> <td>30</td> <td>18</td> <td>0.50</td> <td>0.31</td> </tr> <tr> <td>35</td> <td>21</td> <td>0.57</td> <td>0.36</td> </tr> </tbody> </table> 	$i / ^\circ$	$r / ^\circ$	$\sin i$	$\sin r$	10	5	0.17	0.087	20	12	0.34	0.21	30	18	0.50	0.31	35	21	0.57	0.36	(1) (1) (1) (2) (1)	6
$i / ^\circ$	$r / ^\circ$	$\sin i$	$\sin r$																				
10	5	0.17	0.087																				
20	12	0.34	0.21																				
30	18	0.50	0.31																				
35	21	0.57	0.36																				
4(c)(iii)	<ul style="list-style-type: none"> • Use of large triangle to determine gradient • Refractive index = 1.5 • Value given to 2 or 3 sig fig <p>Accept refractive index in the range 1.3 to 1.7</p>	(1) (1) (1)	3																				
Total for Question 4			15																				

Question number	Answer	Mark
5(a)	<ul style="list-style-type: none"> • Use of $v = \frac{2r^2(\rho_s - \rho_l)g}{9\eta}$ <ul style="list-style-type: none"> • Viscosity = 1.0 Pa s (1) • Answer to 2 or 3 sig fig (1) • Unit: Pa s (Accept N s m⁻²) (1) <p><u>Example of calculation</u> Viscosity = $(2 \times (1.55 \times 10^{-3})^2 \times (8500 - 1260) \times 9.81) / (9 \times 0.038)$ 0.9979 Pa s</p>	4
5(b)	<p>Any 3 from</p> <ul style="list-style-type: none"> • Ensure the temperature is kept constant (1) • Use a long column of liquid (1) • Drop ball in centre of liquid column (1) • Repeat timings (1) • Use light gates (rather than stopwatch) (1) • Use sphere of small diameter compared to diameter of liquid column (1) 	3
	Total for Question 5	7

Write your name here

Surname

Other names

**Pearson Edexcel
International
Advanced Level**

Centre Number

--	--	--	--	--	--

Candidate Number

--	--	--	--	--

Physics

International Advanced Level

Unit 4: Further Mechanics, Fields and Particles

Sample Assessment Materials for first teaching September 2018

Time: 1 hour 45 minutes

Paper Reference

WPH14/01

You must have:

Scientific calculator, Ruler

Total Marks

--

Instructions

- Use **black** ink or **black** ball-point pen.
- **Fill in the boxes** at the top of this page with your name, centre number and candidate number.
- Answer **all** questions.
- Answer the questions in the spaces provided
– *there may be more space than you need.*
- **Show all your working out** in calculations and include units where appropriate.

Information

- The total mark for this paper is 90.
- The marks for **each** question are shown in brackets
– *use this as a guide as to how much time to spend on each question.*
- In questions marked with an **asterisk** (*), marks will be awarded for your ability to structure your answer logically showing how the points that you make are related or follow on from each other where appropriate.

Advice

- Read each question carefully before you start to answer it.
- Try to answer every question.
- Check your answers if you have time at the end.

Turn over ►

S58683A

©2018 Pearson Education Ltd.

1/1/



Pearson

SECTION A

Answer ALL questions.

For questions 1–10 select one answer from A to D and put a cross in the box ☒.
If you change your mind, put a line through the box ~~☒~~ and then
mark your new answer with a cross ☒.

- 1 A current-carrying conductor of length 15 cm is placed in, and perpendicular to, a magnetic field of magnetic flux density 0.065 T. The current through the conductor is 250 mA.

Which of the following is the force on the conductor, in newton, due to the magnetic field?

- A $0.065 \times 250 \times 15$
 B $0.065 \times 0.25 \times 15$
 C $0.065 \times 250 \times 0.15$
 D $0.065 \times 0.25 \times 0.15$

(Total for Question 1 = 1 mark)

- 2 $^{18}_8\text{O}$ is a stable isotope of oxygen.

Which row of the table correctly shows the number of neutrons and the number of protons in a nucleus of $^{18}_8\text{O}$?

	Number of neutrons	Number of protons
<input type="checkbox"/> A	8	10
<input type="checkbox"/> B	9	9
<input type="checkbox"/> C	10	8
<input type="checkbox"/> D	18	8

(Total for Question 2 = 1 mark)

- 3 Which of the following is **not** a vector quantity?

- A angular velocity
 B electric field strength
 C impulse
 D magnetic flux density

(Total for Question 3 = 1 mark)

4 Which of the following correctly expresses the unit of magnetic flux density in SI base units?

- A $\text{A s}^2 \text{kg}^{-1}$
- B $\text{kg A}^{-1} \text{s}^{-2}$
- C $\text{kg s}^{-3} \text{C}^{-1}$
- D $\text{N A}^{-1} \text{m}^{-1}$

(Total for Question 4 = 1 mark)

Questions 5 and 6 refer to the following situation.

A toy bird is moving around in a horizontal circle on the end of a piece of string.

5 Which of the following changes would cause a decrease in the tension in the string?

- A increasing the angular velocity of the toy bird
- B increasing the mass of the toy bird
- C increasing the period of rotation of the toy bird
- D increasing the speed of the toy bird

(Total for Question 5 = 1 mark)

6 The toy bird makes 15 full revolutions in 7 s.

Which of the following gives the angular velocity of the toy bird in rad s^{-1} ?

- A $\frac{15 \times \pi}{7}$
- B $\frac{15 \times 2\pi}{7}$
- C $\frac{7 \times \pi}{15}$
- D $\frac{7 \times 2\pi}{15}$

(Total for Question 6 = 1 mark)

- 7 A ball with momentum p collides with a wall at an angle θ and bounces off with the same speed at the same angle. The collision takes time t .

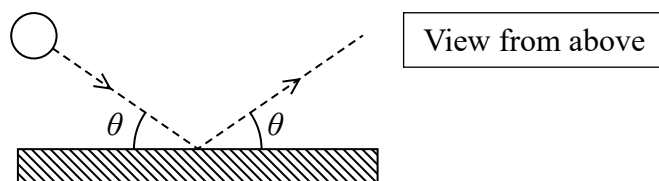

Which of the following equations gives the mean force F acting on the ball during the collision?

- A $F = \frac{p \sin \theta}{t}$
- B $F = \frac{2p \sin \theta}{t}$
- C $F = -\frac{p \sin \theta}{t}$
- D $F = -\frac{2p \sin \theta}{t}$

(Total for Question 7 = 1 mark)

- 8 A proton p and an electron e , with the same velocity, enter a magnetic field that is perpendicular to the direction of their motion. The field acts out of the page.

Which of the following diagrams best represents the motion of the particles?

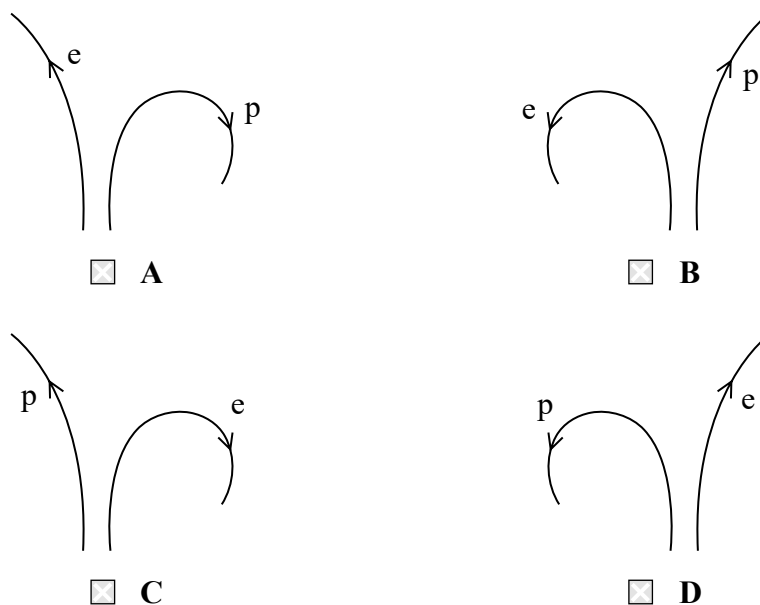

(Total for Question 8 = 1 mark)

Questions 9 and 10 refer to the following situation.

A point positive charge $+Q$ and a point negative charge $-Q$ are separated by a distance r . The magnitude of the force between the charges is F .

9 Which of the following diagrams shows the electric field pattern?

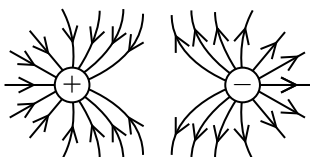

A

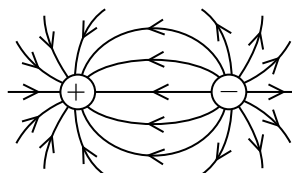

B

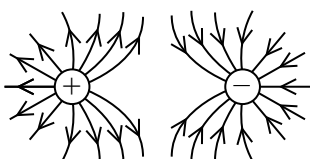

C

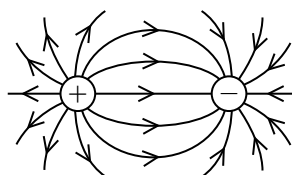

D

(Total for Question 9 = 1 mark)

10 The size of each charge is decreased to $\frac{Q}{2}$ and the separation is decreased to $\frac{r}{4}$.

What is the magnitude of the force between these charges?

A $\frac{F}{4}$

B $\frac{F}{2}$

C $2F$

D $4F$

(Total for Question 10 = 1 mark)

TOTAL FOR SECTION A = 10 MARKS

SECTION B

Answer ALL questions.

11 Determine the electric field strength due to a point charge of -37 nC , at a distance of 5.5 cm from the point charge.

.....

.....

.....

.....

.....

.....

.....

Magnitude of electric field strength =

Direction of electric field

(Total for Question 11 = 3 marks)

12 The table shows the six flavours of quarks and their charges.

Quark			Charge/ e
u	c	t	$\frac{2}{3}$
d	s	b	$-\frac{1}{3}$

Explain why all mesons have charge $+e$, 0 or $-e$.

.....

.....

.....

.....

.....

.....

.....

(Total for Question 12 = 4 marks)

DO NOT WRITE IN THIS AREA

DO NOT WRITE IN THIS AREA

DO NOT WRITE IN THIS AREA

DO NOT WRITE IN THIS AREA

DO NOT WRITE IN THIS AREA

DO NOT WRITE IN THIS AREA

13 Car A was travelling eastwards and car B was travelling northwards. The two cars collided and moved off together in the direction shown. The diagram is not to scale.

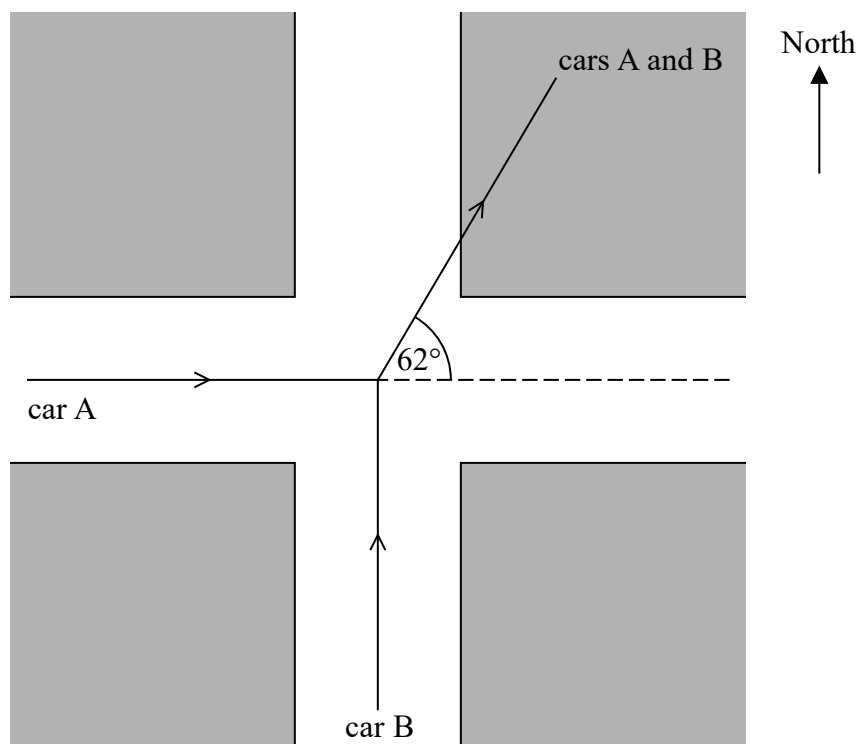

(a) After the collision the cars travelled a distance of 11 m together. The constant deceleration for the cars was 2.4 m s^{-2} .

Show that the initial speed of the cars together after the collision was about 7 m s^{-1} .

(2)

.....

.....

.....

.....

.....

(b) Each driver claimed that the other driver was speeding. The speed limit for car A was 30 km/h (8.3 m s^{-1}) and the speed limit for car B was 50 km/h (13.9 m s^{-1}).

Calculate the speed of each car before the collision to determine whether either car was speeding before the collision.

mass of car A = 1100 kg

mass of car B = 1400 kg

(6)

.....

.....

.....

.....

.....

.....

.....

.....

.....

.....

Speed of car A =

Speed of car B =

Conclusion

.....

.....

.....

(Total for Question 13 = 8 marks)

DO NOT WRITE IN THIS AREA

DO NOT WRITE IN THIS AREA

DO NOT WRITE IN THIS AREA

14 Particle tracks in detectors can be used to determine the distance travelled by particles between creation and decay.

One type of particle, with a known average lifetime, travels an average distance x between creation and decay when its speed is v .

(a) Sketch a graph on the axes below to show how x varies with v , until v approaches the speed of light.

(2)

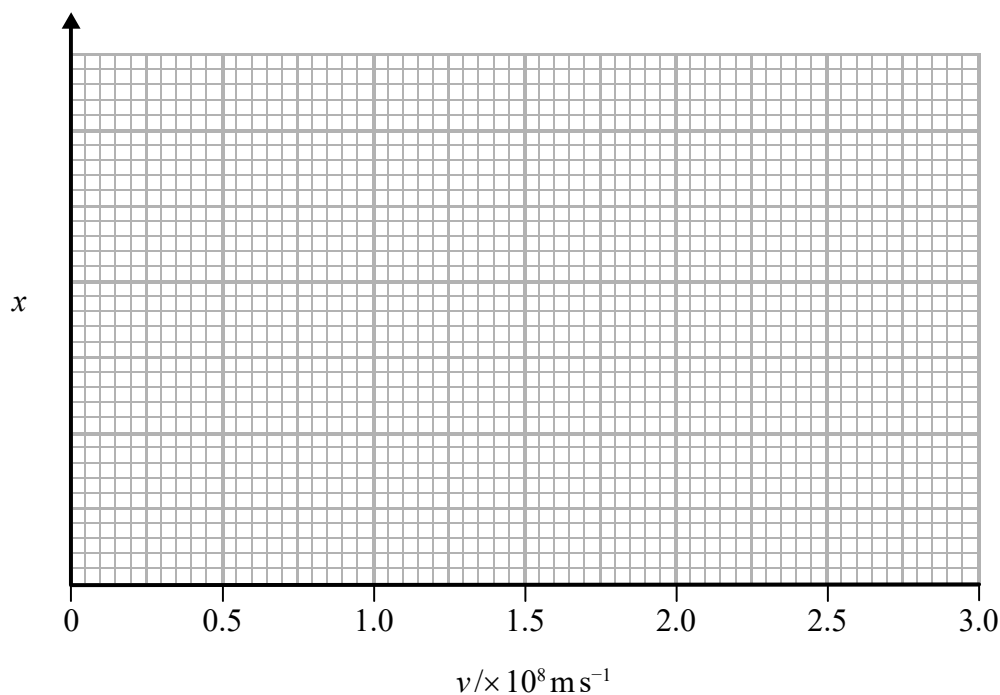

(b) Explain the shape of the graph.

(3)

.....

.....

.....

.....

.....

.....

.....

.....

.....

(Total for Question 14 = 5 marks)

15 Black holes have such high gravitational field strength that nothing, including light, can escape from within them.

It has been suggested that black holes can lose mass over time.

Energy from a black hole allows the production of a particle-antiparticle pair outside the black hole. The two particles move off in opposite directions. One particle falls into the black hole and the other escapes. Therefore the energy of the escaping particle is lost by the black hole.

(a) The particles created are a muon and an anti-muon, each with mass $106 \text{ MeV}/c^2$.

Calculate the minimum mass, in kg, lost by the black hole.

(3)

.....

.....

.....

.....

.....

.....

.....

.....

.....

.....

Minimum mass = kg

(b) Explain why the mass calculated in (a) is a minimum value.

(2)

.....

.....

.....

.....

.....

(Total for Question 15 = 5 marks)

DO NOT WRITE IN THIS AREA

DO NOT WRITE IN THIS AREA

DO NOT WRITE IN THIS AREA

16 Rutherford's alpha particle scattering experiments led to the conclusion that an atom is mostly empty space and contains a massive charged nucleus.

An alpha particle of energy 7.7 MeV is moving along a path directly towards a gold nucleus.

Determine whether the closest distance of the alpha particle to the centre of the nucleus is consistent with this conclusion.

diameter of gold atom = 2.6×10^{-10} m

charge on a gold nucleus = $+79e$

(5)

.....

.....

.....

.....

.....

.....

.....

.....

.....

.....

.....

(Total for Question 16 = 5 marks)

17 The diagram shows an electron deflection tube that includes an electron gun and two parallel plates.

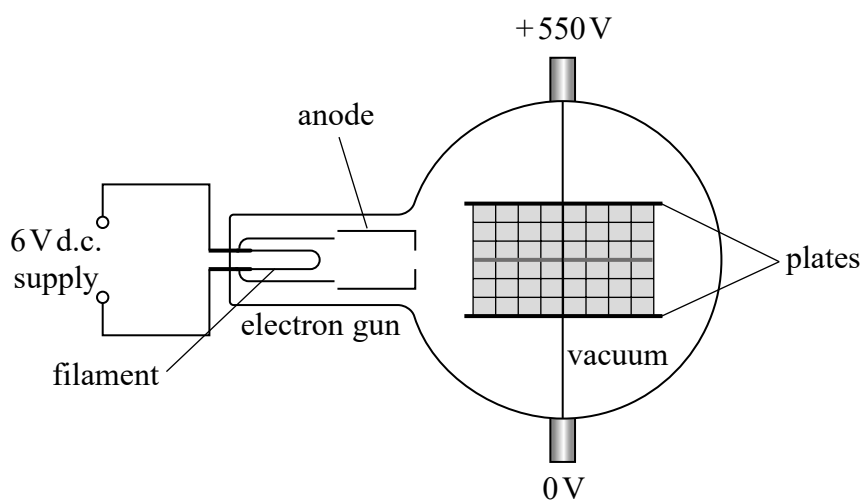

(a) The electron gun consists of a hot metal filament and a positively charged anode.

Describe how this produces a beam of electrons.

(2)

.....

.....

.....

.....

DO NOT WRITE IN THIS AREA

DO NOT WRITE IN THIS AREA

DO NOT WRITE IN THIS AREA

(ii) Calculate the de Broglie wavelength of an electron moving at a speed of $2.7 \times 10^7 \text{ m s}^{-1}$.

(2)

.....

.....

.....

Wavelength =

(Total for Question 17 = 10 marks)

18 Neutrons in a nucleus are stable. However, free neutrons decay with a mean lifetime of about 15 minutes.

The decay of a neutron is given by

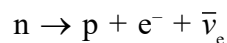

(a) Describe how three conservation laws apply to this decay.

(6)

Law 1:

.....

.....

Law 2:

.....

.....

Law 3:

.....

.....

DO NOT WRITE IN THIS AREA

DO NOT WRITE IN THIS AREA

DO NOT WRITE IN THIS AREA

- (b) A stationary free neutron decays. It may be assumed that only the electron has significant kinetic energy after the decay.

The table gives the mass of the particles involved in the decay. The mass of the neutrino may be considered to be negligible.

	Mass / MeV/c ²
Neutron	939.5656
Proton	938.2723
Electron	0.5110

Determine the momentum of the electron.

(4)

.....

.....

.....

.....

.....

.....

.....

.....

.....

.....

Momentum =

(Total for Question 18 = 10 marks)

19 The European Laboratory for Particle Physics is operated by CERN and contains the Large Hadron Collider (LHC).

Protons go through a number of stages in different accelerators before they enter the LHC.

The first stage is a linear accelerator (linac).

*(a) The photographs show the drift tubes at the beginning and at the end of a linac.

The beam of protons travels from left to right.

drift tubes at the beginning of the linac



drift tubes at the end of the linac

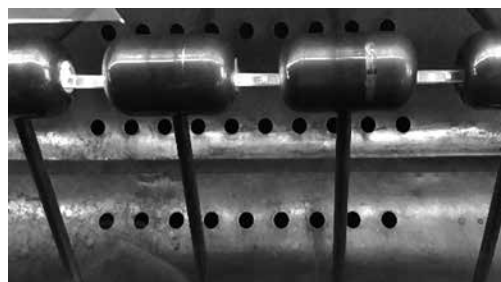

—————→
direction of travel of proton beam

Explain why the drift tubes and the gaps between them increase in size along the length of the linac.

(6)

.....

.....

.....

.....

.....

.....

.....

.....

.....

.....

.....

.....

.....

.....

.....

.....

.....

.....

.....

.....

.....

.....

.....

(b) The LHC has a number of straight sections with curved sections between them. The curved path of protons is maintained by a strong magnetic field. The radius of the curved path is given by $r = p/BQ$.

(i) Derive the equation $r = p/BQ$.

(3)

(ii) Protons of energy 6.5 TeV move along a curved path of radius 2800 m. At these energies, particle energy $E = pc$ where c is the speed of light.

Calculate the magnetic flux density required.

(3)

Magnetic flux density =

(Total for Question 19 = 12 marks)

- 20 A flash bulb for a camera must transfer a lot of energy in a very short time. This requires a higher potential difference (p.d.) than can be provided by a 1.5 V cell. A capacitor is used that can be charged to a p.d. over 300 V.

The diagram represents a simplified circuit for a camera flash unit.

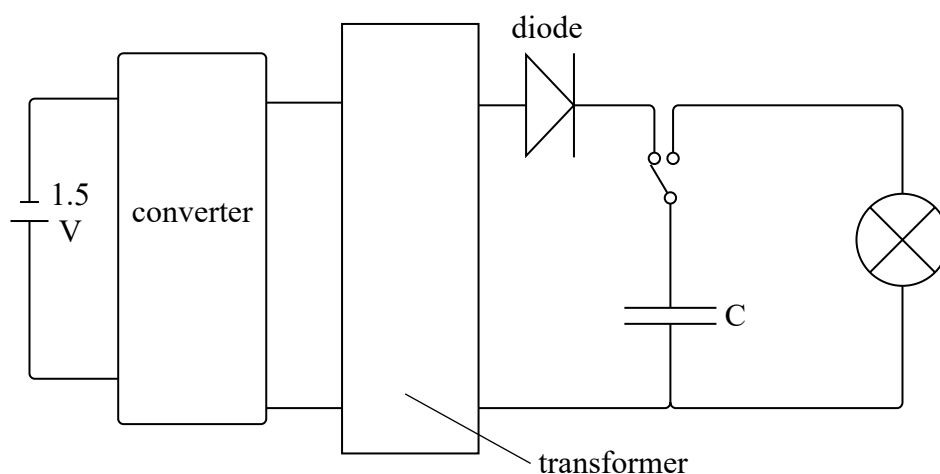

Direct current from the cell is converted to alternating current by this converter.

The transformer increases the p.d. and the capacitor is charged. When the flash is required, the capacitor is connected in series with the bulb, which then flashes briefly.

- (a) The transformer consists of two coils wound around a common iron core. One coil is connected in series with the converter. The second coil is connected to the capacitor circuit.
- (i) Explain how this arrangement creates a current in the capacitor charging circuit.

(4)

(ii) Explain why the diode must be included in this circuit.

(2)

.....

.....

.....

(b) The capacitor is charged until the p.d. across it reaches 330 V.

(i) Calculate the charge on the capacitor when the p.d. reaches 330 V.

capacitance of capacitor = $180 \mu\text{F}$

(2)

.....

.....

.....

Charge =

(ii) Calculate the energy stored by the capacitor.

(2)

.....

.....

.....

Energy =

DO NOT WRITE IN THIS AREA

(iii) The graph shows how the p.d. across the capacitor varies with time as the capacitor discharges.

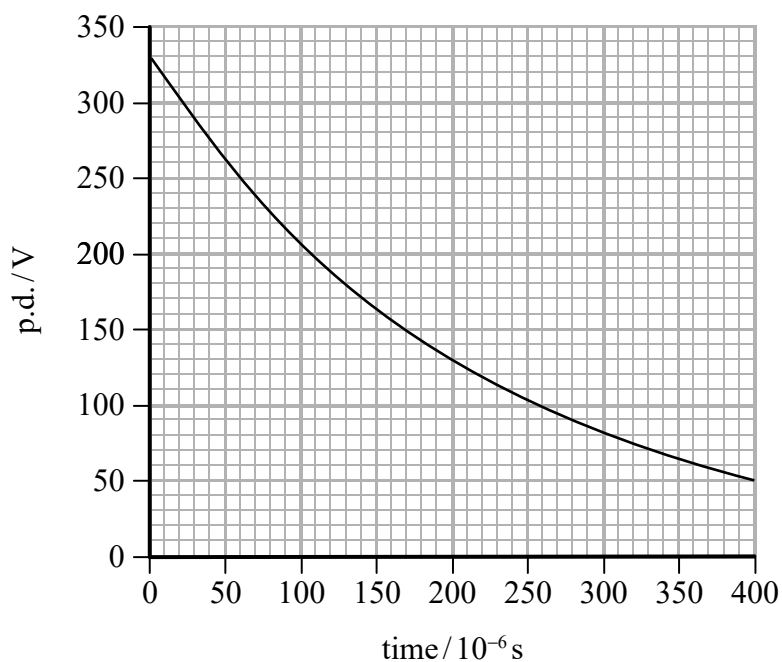

1. Calculate the initial current in the capacitor circuit as the capacitor discharges. (4)

.....

.....

.....

.....

.....

.....

.....

.....

Initial current =

2. Determine the time taken for the energy stored on the capacitor to reduce by 80%.

(4)

.....

.....

.....

.....

.....

.....

.....

.....

Time taken =

(Total for Question 20 = 18 marks)

TOTAL FOR SECTION B = 80 MARKS
TOTAL FOR PAPER = 90 MARKS

DO NOT WRITE IN THIS AREA

DO NOT WRITE IN THIS AREA

DO NOT WRITE IN THIS AREA

DO NOT WRITE IN THIS AREA

DO NOT WRITE IN THIS AREA

DO NOT WRITE IN THIS AREA

BLANK PAGE

Unit 4: Further Mechanics, Fields and Particles - Mark scheme

Question number	Answer	Mark
1	D	1
2	C	1
3	A	1
4	B	1
5	C	1
6	B	1
7	D	1
8	B	1
9	D	1
10	D	1

Question number	Answer	Mark
11	<ul style="list-style-type: none"> • Use of $E = Q/4\pi\epsilon_0 r^2$ (1) • $E = 1.1 \times 10^5 \text{ N C}^{-1}$ (1) • Direction is towards the point charge (1) <p><u>Example of calculation</u> $E = Q/4\pi\epsilon_0 r^2$ $E = 3.7 \times 10^{-9} \text{ C} / (4\pi \times 8.85 \times 10^{-12} \text{ F m}^{-1} (0.055 \text{ m})^2)$ $E = 1.1 \times 10^5 \text{ N C}^{-1}$</p>	3
	Total for Question 11	3

Question number	Answer	Mark
12	<ul style="list-style-type: none"> • Identifies meson structure quark – antiquark (1) • 1 correct combination 1 mark • 2 or 3 correct combinations 2 marks • All four correct combinations 3 marks (3) <p><u>Combinations are</u> $(+\frac{2}{3}e) + (-\frac{2}{3}e) = 0$ $(+\frac{2}{3}e) + (+\frac{1}{3}e) = +e$ $(-\frac{1}{3}e) + (-\frac{2}{3}e) = -e$ $(-\frac{1}{3}e) + (+\frac{1}{3}e) = 0$</p>	4
	Total for Question 12	4

Question number	Answer	Mark
13(a)	<ul style="list-style-type: none"> Use of $v^2 = u^2 + 2as$ with $v = 0$ Or use of equivalent pair of equations (1) Initial speed = 7.3 m s^{-1} (1) <p><u>Example of calculation</u> $0 = u^2 + 2 \times (-2.4 \text{ m s}^{-2}) \times 11 \text{ m}$ $u = 7.3 \text{ m s}^{-1}$</p>	2
13(b)	<ul style="list-style-type: none"> Use of $p = mv$ (allow ecf of value from (a)) (1) Use of correct trigonometrical function for East–West momentum (1) Use of correct trigonometrical function for North–South momentum (1) Initial speed of car A = 7.8 m s^{-1} (1) Initial speed of car B = 11.5 m s^{-1} (1) So neither car was speeding (1) Or conclusion consistent with their calculated values (1) <p><u>Example of calculation</u> $p = (1100 \text{ kg} + 1400 \text{ kg}) \times 7.3 \text{ m s}^{-1}$ $= 18250 \text{ kg m s}^{-1}$ $p_A = 18250 \text{ kg m s}^{-1} \times \cos 62^\circ$ $= 8570 \text{ kg m s}^{-1}$ $u_N = 8570 \text{ kg m s}^{-1} \div 1100 \text{ kg} = 7.8 \text{ m s}^{-1}$ $p_B = 18250 \text{ kg m s}^{-1} \times \sin 62^\circ$ $= 16100 \text{ kg m s}^{-1}$ $u_B = 16100 \text{ kg m s}^{-1} \div 1400 \text{ kg} = 11.5 \text{ m s}^{-1}$ $7.8 \text{ m s}^{-1} < 8.3 \text{ m s}^{-1}$ and $11.5 \text{ m s}^{-1} < 13.9 \text{ m s}^{-1}$ So neither car was speeding</p>	6
	Total for Question 13	8

Question number	Answer	Mark
14(a)	<ul style="list-style-type: none"> Initially a straight line with a positive gradient Or reference to $s = vt$ (1) Then an upward curve that does not reach $v = 3.0 \times 10^8 \text{ m/s}$ (1) 	2
14(b)	<ul style="list-style-type: none"> Initially distance proportional to speed (1) At higher speeds there is a relativistic increase in the lifetime of the particles (1) So the particles travel further as their lifetime is extended (1) 	3
	Total for Question 14	5

Question number	Answer	Mark
15(a)	<ul style="list-style-type: none"> Use of factor 1.6×10^{-19} C to convert eV to J (1) Use of $\Delta m = \Delta E / c^2$ (1) mass = 1.9×10^{-28} kg (1) <p><u>Example of calculation</u> $E = 106 \times 10^6 \text{ eV} \times 1.6 \times 10^{-19} \text{ C} = 1.7 \times 10^{-11} \text{ J}$ $m = 1.7 \times 10^{-11} \text{ J} \div (3.0 \times 10^8 \text{ m s}^{-1})^2$ $= 1.9 \times 10^{-28} \text{ kg}$</p>	3
15(b)	<ul style="list-style-type: none"> the minimum value assumes no kinetic energy is carried away by the particle (1) a particle with kinetic energy would require more energy from the black hole and hence a greater mass decrease from the black hole (1) 	2
Total for Question 15		5

Question number	Answer	Mark
16	<ul style="list-style-type: none"> Energy conversion using 1.6×10^{-19} C (1) Use of $E_p = Vq$ (1) Use of $Q/4\pi\epsilon_0 r$ with $Q = 79e$ (1) $r = 2.9 \times 10^{-14}$ m (1) This is about 10 000 times smaller than the atom, so it is consistent with the conclusion that there is a massive nucleus in an atom that is mostly empty space (1) Or conclusion consistent with their calculated values (1) <p><u>Example of calculation</u> Initial $E_k = 7.7 \times 10^6 \times 1.6 \times 10^{-19} \text{ C} = 1.23 \times 10^{-12} \text{ J}$ $V = 7.36 \times 10^{-13} \text{ J} \div (2 \times 1.6 \times 10^{-19} \text{ C}) = 3.85 \times 10^6 \text{ V}$ $r = 79 \times 1.6 \times 10^{-19} \text{ C} \div (4 \times \pi \times 8.85 \times 10^{-12} \text{ F m}^{-1} \times 3.85 \times 10^6 \text{ V})$ $r = 2.9 \times 10^{-14} \text{ m}$</p>	5
Total for Question 16		5

Question number	Answer	Mark
17(a)	<ul style="list-style-type: none"> Electrons produced by thermionic emission (at the filament) (1) Electrons are accelerated by an electric field between the anode and the cathode (1) 	2
17(b)(i)	<ul style="list-style-type: none"> Use of $E = V/d$ and $F = EQ$ (1) Use of $F = ma$ (1) Use of $v = s/t$ (1) Use of $s = ut + \frac{1}{2}at^2$ with $u = 0$ (1) $s = 0.013$ m (1) which is less than 0.025 m so it doesn't hit the plate (1) Or give credit for answer consistent with calculated value (1) <p><u>Example of calculation</u> $E = 550 \text{ V} / 0.05 \text{ m} = 11\,000 \text{ V m}^{-1}$ $F = 11\,000 \text{ V m}^{-1} \times 1.6 \times 10^{-19} \text{ C}$ $F = 1.76 \times 10^{-15} \text{ N}$ $a = F/m = 1.76 \times 10^{-15} \text{ N} / 9.11 \times 10^{-31} \text{ kg}$ $a = 1.93 \times 10^{15} \text{ m s}^{-2}$ $t = 0.10 \text{ m} / 2.7 \times 10^7 \text{ m s}^{-1} = 3.70 \times 10^{-9} \text{ s}$ $s = \frac{1}{2} \times 1.93 \times 10^{15} \text{ m s}^{-2} \times (3.70 \times 10^{-9} \text{ s})^2$ $s = 0.013 \text{ m}$</p>	6
17(b)(ii)	<ul style="list-style-type: none"> Use of $\lambda = h/p$ (1) $\lambda = 2.7 \times 10^{-11} \text{ m}$ (1) <p><u>Example of calculation</u> $\lambda = 6.63 \times 10^{-34} \text{ J s} \div (9.11 \times 10^{-31} \text{ kg} \times 2.7 \times 10^7 \text{ m s}^{-1})$ $\lambda = 2.7 \times 10^{-11} \text{ m}$</p>	2
Total for Question 17		10

Question number	Answer	Mark
18(a)	<p>For each law, states what is conserved and uses values for the particles in the equation to demonstrate conservation</p> <ul style="list-style-type: none"> • baryon number is conserved (1) • neutron(1) \rightarrow proton(1) + electron(0) + antineutrino(0) (1) • lepton number is conserved (1) • neutron(0) \rightarrow proton(0) + electron(+1) + antineutrino(-1) (1) • charge is conserved (1) • neutron(0) \rightarrow proton(+1) + electron(-1) + antineutrino(0) (1) 	6
18(b)	<ul style="list-style-type: none"> • Attempt at calculation of mass difference (1) • eV conversion (1) • Use of $E_k = p^2/2m$ (1) • $p = 4.77 \times 10^{-22} \text{ kg m s}^{-1}$ (1) <p><u>Example of calculation</u></p> $\Delta m = m_n - m_p - m_e$ $\Delta m = 939.5656 \text{ MeV}/c^2 - 938.2723 \text{ MeV}/c^2 - 0.5110 \text{ MeV}/c^2$ $= 0.7823 \text{ MeV}/c^2$ $E_k = 0.7823 \times 10^6 \text{ eV} \times 1.60 \times 10^{-19} \text{ C} = 1.25 \times 10^{-13} \text{ J}$ $p = \sqrt{(2 \times 1.25 \times 10^{-13} \text{ J} \times 9.11 \times 10^{-31} \text{ kg})}$ $p = 4.77 \times 10^{-22} \text{ kg m s}^{-1}$	4
	Total for Question 18	10

Question number	Answer	Mark																				
19(a)	<p>This question assesses a student's ability to show a coherent and logically structured answer with linkages and fully-sustained reasoning.</p> <p>Marks are awarded for indicative content and for how the answer is Structured and shows lines of reasoning.</p> <p>The following table shows how the marks should be awarded for indicative content.</p> <table border="1" data-bbox="336 517 799 831"> <thead> <tr> <th>Number of indicative marking points seen in answer</th> <th>Number of marks awarded for indicative marking points</th> </tr> </thead> <tbody> <tr> <td>6</td> <td>4</td> </tr> <tr> <td>5-4</td> <td>3</td> </tr> <tr> <td>3-2</td> <td>2</td> </tr> <tr> <td>1</td> <td>1</td> </tr> <tr> <td>0</td> <td>0</td> </tr> </tbody> </table> <p>The following table shows how the marks should be awarded for structure and lines of reasoning.</p> <table border="1" data-bbox="336 904 1209 1375"> <thead> <tr> <th></th> <th>Number of marks awarded for structure of answer and sustained line of reasoning</th> </tr> </thead> <tbody> <tr> <td>Answer shows a coherent and logical structure with linkages and fully sustained lines of reasoning demonstrated throughout</td> <td>2</td> </tr> <tr> <td>Answer is partially structured with some linkages and lines of reasoning</td> <td>1</td> </tr> <tr> <td>Answer has no linkages between points and is unstructured</td> <td>0</td> </tr> </tbody> </table> <p>Total marks awarded is the sum of marks for indicative content and the marks for structure and lines of reasoning.</p> <p>Indicative content</p> <ul style="list-style-type: none"> • Electric field accelerates proton across gap • Potential difference oscillates at a constant frequency so the time in the gaps is constant for each cycle • Enters successive gaps at greater speeds so the gaps must increase in size • Proton has constant speed within the drift tube • Potential difference oscillates at a constant frequency so time in tubes is constant for each cycle • Goes faster in successive tubes so the tubes must increase in length 	Number of indicative marking points seen in answer	Number of marks awarded for indicative marking points	6	4	5-4	3	3-2	2	1	1	0	0		Number of marks awarded for structure of answer and sustained line of reasoning	Answer shows a coherent and logical structure with linkages and fully sustained lines of reasoning demonstrated throughout	2	Answer is partially structured with some linkages and lines of reasoning	1	Answer has no linkages between points and is unstructured	0	6
Number of indicative marking points seen in answer	Number of marks awarded for indicative marking points																					
6	4																					
5-4	3																					
3-2	2																					
1	1																					
0	0																					
	Number of marks awarded for structure of answer and sustained line of reasoning																					
Answer shows a coherent and logical structure with linkages and fully sustained lines of reasoning demonstrated throughout	2																					
Answer is partially structured with some linkages and lines of reasoning	1																					
Answer has no linkages between points and is unstructured	0																					

Question number	Answer	Mark
19(b)(i)	<ul style="list-style-type: none"> Force on proton due to magnetic field (BQv) = centripetal force (mv^2/r) (1) Use $p = mv$ (1) Correct algebraic link to $r = p/BQ$ (1) 	3
19(b)(ii)	<ul style="list-style-type: none"> Use of $E = pc$ (1) Use of $r = p/BQ$ (1) $B = 7.7$ T (1) <p><u>Example of calculation</u> $p = 6.5 \times 10^{12} \times 1.6 \times 10^{-19} \text{ C} \div 3.00 \times 10^8 \text{ m s}^{-1}$ $= 3.47 \times 10^{-15} \text{ N s}$ $B = 3.47 \times 10^{-15} \text{ N s} \div (2800 \text{ m} \times 1.6 \times 10^{-19} \text{ C})$ $B = 7.7 \text{ T}$</p>	3
	Total for Question 19	12

Question number	Answer	Mark
20(a)(i)	<ul style="list-style-type: none"> Alternating current produces an alternating/varying magnetic field (1) Magnetic flux in first coil linked to second coil Or lines of flux cutting coil in second coil (1) Or so there is varying flux in second coil (1) An e.m.f. is therefore induced in the second coil (1) There is a current in the capacitor circuit because there is a complete circuit (1) 	4
20(a)(ii)	<ul style="list-style-type: none"> Alternating current will charge the capacitor during one half cycle and discharge it during the other half cycle (1) so a diode is needed to convert the ac to dc (1) Or the diode only conducts during every alternate half cycle (1) 	2
20(b)(i)	<ul style="list-style-type: none"> Use of $C = Q/V$ (1) $Q = 0.059 \text{ C}$ (1) <p><u>Example of calculation</u> $Q = 1.8 \times 10^{-4} \text{ F} \times 330 \text{ V}$ $Q = 0.059 \text{ C}$</p>	2
20(b)(ii)	<ul style="list-style-type: none"> Use of $W = \frac{1}{2} QV$ or a derived equation (1) $W = 9.8 \text{ J}$ (1) <p><u>Example of calculation</u> $W = 0.5 \times 0.059 \text{ C} \times 330 \text{ V}$ $W = 9.8 \text{ J}$</p>	2
20(b)(iii) 1.	<ul style="list-style-type: none"> Use of $V = V_0/e$ to find time constant Or intercept with t axis using initial tangent to find time constant (1) Use of time constant = RC (1) Use of $V = IR$ (1) $I = 270 \text{ A}$ (1) <p><u>Example of calculation</u> $V_0/e = 330 \text{ V} / e = 121 \text{ V}$ Time constant = $217 \times 10^{-6} \text{ s}$ $217 \times 10^{-6} \text{ s} = R \times 1.8 \times 10^{-4} \text{ F}$ $R = 1.2 \text{ } \Omega$ $I = 330 \text{ V} / 1.2 \text{ } \Omega$ $= 274 \text{ A}$</p>	4

Question number	Answer	Mark
20(b)(iii) 2.	<p>Either</p> <ul style="list-style-type: none"> • Use of 20% of W_0 (1) • Use of $W = \frac{1}{2}CV^2$ (1) • Use $V = V_0 e^{\frac{-t}{RC}}$ (1) • $t = 1.7 \times 10^{-4}$ s (1) <p>Or</p> <ul style="list-style-type: none"> • Calculate 20% of initial energy = 1.96 J (1) • Use of $W = \frac{1}{2} QV$ and $C = Q/V$ (1) • Use of graph to determine corresponding value of t (1) • $t = 1.7 \times 10^{-4}$ s (1) <p><u>Example of calculation</u></p> $V/V_0 = \sqrt{0.2} = 0.45$ $0.45 V_0 = V_0 e^{\frac{-t}{RC}}$ $\ln 0.45 = \frac{-t}{0.00018 \text{ F} \times 1.2 \Omega}$ $t = 1.7 \times 10^{-4} \text{ s}$ <p>Or</p> $W = \frac{1}{2} QV \text{ and } C = Q/V \text{ so } W = \frac{1}{2} CV^2$ $V = \sqrt{(2 \times 1.96 \text{ J}) \div (1.8 \times 10^{-4} \text{ F})} = 148 \text{ V}$ $t = 1.7 \times 10^{-4} \text{ s}$	4
	Total for Question 20	18

Write your name here

Surname

Other names

**Pearson Edexcel
International
Advanced Level**

Centre Number

--	--	--	--	--	--

Candidate Number

--	--	--	--	--	--

Physics

International Advanced Level

**Unit 5: Thermodynamics, Radiation, Oscillations
and Cosmology**

Sample Assessment Materials for first teaching September 2018

Time: 1 hour 45 minutes

Paper Reference

WPH15/01

You must have:

Scientific calculator, ruler

Total Marks

--

Instructions

- Use **black** ink or **black** ball-point pen.
- **Fill in the boxes** at the top of this page with your name, centre number and candidate number.
- Answer **all** questions.
- Answer the questions in the spaces provided – *there may be more space than you need.*
- **Show all your working in calculations and include units where appropriate.**

Information

- The total mark for this paper is 90.
- The marks for **each** question are shown in brackets – *use this as a guide as to how much time to spend on each question.*
- In questions marked with an **asterisk** (*), marks will be awarded for your ability to structure your answer logically showing how the points that you make are related or follow on from each other where appropriate.

Advice

- Read each question carefully before you start to answer it.
- Try to answer every question.
- Check your answers if you have time at the end.

Turn over ►

S58684A

©2018 Pearson Education Ltd.

1/1/1/1/



Pearson

SECTION A

Answer ALL questions.

For questions 1–10, select one answer from A to D and put a cross in the box ☒.
If you change your mind, put a line through the box ☒ and then
mark your new answer with a cross ☒.

- 1 The gravitational field strength at the surface of the Earth is 9.81 N kg^{-1} . A satellite is orbiting at a height above the ground equal to the radius of the Earth.

What is the gravitational field strength at this height?

- A 0.00 N kg^{-1}
 B 2.45 N kg^{-1}
 C 4.91 N kg^{-1}
 D 9.81 N kg^{-1}

(Total for Question 1 = 1 mark)

- 2 A sealed gas jar contains a mixture of different gases. At a given temperature, the mean kinetic energy of the molecules of each gas

- A depends on how much of each gas is present.
 B is greater for the gas with less massive molecules.
 C is greater for the gas with more massive molecules.
 D is the same for each gas in the mixture.

(Total for Question 2 = 1 mark)

- 3 When energy is supplied to a substance, changes in the average molecular kinetic energy E_k and the average molecular potential energy E_p can occur.

Select the row in the table which correctly identifies the changes in E_k and E_p when energy is supplied to an ideal gas.

	E_k	E_p
<input type="checkbox"/> A	increase	increase
<input type="checkbox"/> B	increase	no change
<input type="checkbox"/> C	no change	increase
<input type="checkbox"/> D	increase	decrease

(Total for Question 3 = 1 mark)

4 Which of the following is the reason why the ultimate fate of the Universe is uncertain?

- A Atmospheric absorption limits our observations.
- B Our galaxy is not typical of other galaxies in the Universe.
- C The total average density of the Universe is uncertain.
- D We cannot observe very distant galaxies.

(Total for Question 4 = 1 mark)

5 When a driver force causes a system to oscillate, the system always

- A exhibits resonance.
- B experiences a large increase in amplitude.
- C oscillates at its natural frequency.
- D oscillates at the driver frequency.

(Total for Question 5 = 1 mark)

6 A standard candle is a distance x from the Earth. The intensity of the radiation at the surface of the Earth is I .

A second standard candle of the same luminosity is observed. The intensity of the radiation at the surface of the Earth is $4I$.

Which of the following is the distance of the second standard candle from the Earth?

- A $4x$
- B $2x$
- C $x/2$
- D $x/4$

(Total for Question 6 = 1 mark)

7 The interior of a star has conditions that are ideal for sustainable fusion reactions. Which of the following are the general conditions required for sustainable fusion?

- A large amount of hydrogen and very high temperature
- B large amount of hydrogen and very high pressure
- C very high density and very high pressure
- D very high density and very high temperature

(Total for Question 7 = 1 mark)

8 Radioactive decay is a random process. Which of the following statements about radioactive decay is correct?

- A We are not able to predict when a particular nucleus will decay.
- B We are not able to predict the number of nuclei that will decay in a second.
- C We do not know what a particular nucleus will decay into.
- D We are able to influence when a particular nucleus will decay.

(Total for Question 8 = 1 mark)

9 Stellar parallax can be used to determine the distances to stars that are relatively close to the Earth.

Which of the following is the reason that this method is unsuitable for more distant stars?

- A The luminosity of these stars is too high.
- B The luminosity of these stars is too low.
- C The parallax angle is too large.
- D The parallax angle is too small.

(Total for Question 9 = 1 mark)

DO NOT WRITE IN THIS AREA

DO NOT WRITE IN THIS AREA

DO NOT WRITE IN THIS AREA

10 At the surface of the Earth the gravitational potential is V and the gravitational force on an object is F . The radius of the Earth is R .

The object is moved to a height $2R$ above the surface of the Earth.

Select the row of the table that gives the gravitational potential and gravitational force at height $2R$.

	Gravitational force	Gravitational potential
<input type="checkbox"/> A	$\frac{F}{4}$	$-\frac{V}{2}$
<input type="checkbox"/> B	$\frac{F}{9}$	$-\frac{V}{3}$
<input type="checkbox"/> C	$\frac{F}{4}$	$-\frac{V}{4}$
<input type="checkbox"/> D	$\frac{F}{9}$	$-\frac{V}{9}$

(Total for Question 10 = 1 mark)

TOTAL FOR SECTION A = 10 MARKS

SECTION B

Answer ALL questions.

- 11** When nearby stars are observed over a number of years, the stars are seen to undergo a very small movement against the background of more distant stars.

Describe how astronomers use this movement to calculate the distance to a nearby star.

(3)

.....

.....

.....

.....

.....

.....

.....

.....

.....

.....

.....

.....

.....

.....

.....

.....

.....

.....

.....

.....

.....

.....

.....

(Total for Question 11 = 3 marks)

DO NOT WRITE IN THIS AREA

DO NOT WRITE IN THIS AREA

DO NOT WRITE IN THIS AREA

DO NOT WRITE IN THIS AREA

DO NOT WRITE IN THIS AREA

DO NOT WRITE IN THIS AREA

12 An electric kettle is used to heat water to make coffee. The kettle has a power of 2.80 kW. Each cup of coffee requires 325 g of hot water.

(a) The kettle is used to heat water for 3 cups of coffee.

Calculate the time taken to increase the temperature of the water from 8.5 °C to 100 °C.

specific heat capacity of water = 4190 J kg⁻¹ K⁻¹

(3)

Time taken =

(b) When the water in the kettle is boiling at a steady rate, some energy is transferred to the steam and some to the surroundings.

A mass of 136 g of steam is produced in 125 seconds.

Calculate the rate of transfer of thermal energy to the surroundings during this time.

specific latent heat of vaporisation of water = 2.26 × 10⁶ J kg⁻¹

(3)

Rate of transfer of thermal energy =

(Total for Question 12 = 6 marks)

- 13 Adding uranium to a glass mix gives the glass a yellow-green colour. In the last century this glass was often made into decorative items such as vases.



(https://carlwillis.files.wordpress.com/2010/05/vase_melstrom.jpg)

- (a) Naturally-occurring uranium mostly consists of uranium-238. Uranium-238 undergoes alpha decay to produce an unstable isotope of thorium.

Complete the nuclear equation for this decay.



(2)

- (b) The activity of a vase is measured to be 36.7 Bq.

- (i) Calculate the number of uranium nuclei in the vase.

$$\text{half-life of uranium} = 1.41 \times 10^{17} \text{ s}$$

(3)

.....

.....

.....

.....

.....

.....

.....

Number of uranium nuclei =

- (ii) Suggest why your calculation may overestimate the number of uranium nuclei in the vase.

(1)

.....

.....

(Total for Question 13 = 6 marks)

DO NOT WRITE IN THIS AREA

DO NOT WRITE IN THIS AREA

DO NOT WRITE IN THIS AREA

14 A balloon is filled with helium gas at a pressure of $1.10 \times 10^5 \text{ Pa}$ and a temperature of 23.5°C . The balloon has a volume of 0.0142 m^3 .

(a) Calculate the number of helium atoms in the balloon.

(3)

.....

.....

.....

.....

.....

.....

.....

Number of helium atoms =

(b) Explain why the volume of the balloon will increase if the temperature of the helium is increased.

(2)

.....

.....

.....

.....

.....

.....

.....

(Total for Question 14 = 5 marks)

15 During the process of fusion, changes in binding energy may result in the release of energy from the nucleus.

(a) State what is meant by the binding energy of a nucleus.

(1)

.....

.....

(b) Data for the masses of some particles are given in the table.

particle	mass / u
proton	1.00728
neutron	1.00867
tritium nucleus	3.01551

(i) Calculate the binding energy, in MeV, of a tritium nucleus, ${}^3_1\text{H}$.

(4)

.....

.....

.....

.....

.....

.....

Binding energy = MeV

(ii) Explain why the fusion of massive nuclei does not release energy.

(2)

.....

.....

.....

.....

(Total for Question 15 = 7 marks)

DO NOT WRITE IN THIS AREA

DO NOT WRITE IN THIS AREA

DO NOT WRITE IN THIS AREA

16 The luminosity of the Sun is 3.85×10^{26} W.

(a) Calculate the radius of the Sun.

surface temperature of the Sun = 5800 K

(2)

.....

.....

.....

.....

.....

Radius of the Sun =

(b) A solar array is a combination of solar cells. A solar array covers an area of 250 000 m².

Calculate the maximum electrical power that can be supplied by this solar array.

percentage of solar power dissipated in the atmosphere = 25%

efficiency of the solar array = 22%

distance of the Sun from the Earth = 1.50×10^{11} m

(5)

.....

.....

.....

.....

.....

.....

.....

.....

.....

.....

(Total for Question 16 = 7 marks)

17 In November 1940 the wind caused oscillations of the road bridge over Tacoma Narrows in the United States. The amplitude of the oscillations became so large that the bridge collapsed.

(a) Name the effect that caused the bridge to oscillate with increasing amplitude. (1)

.....

(b) The vertical oscillations of the bridge can be modelled using the equations of simple harmonic motion. Calculate the maximum acceleration of the bridge when it was oscillating 38 times per minute and the amplitude of its oscillations was 0.90 m. (4)

.....

.....

.....

.....

.....

Maximum acceleration =

(c) As the amplitude of the vertical oscillations increased, people left the bridge leaving their cars behind.

(i) Complete a free-body force diagram for a car in contact with the road surface of the bridge. (1)



(ii) Assess the validity of the suggestion that at certain points in the oscillation of the bridge any car would lose contact with the road.

(3)

.....

.....

.....

.....

.....

(Total for Question 17 = 9 marks)

DO NOT WRITE IN THIS AREA

DO NOT WRITE IN THIS AREA

DO NOT WRITE IN THIS AREA

18 The photograph shows a battery-powered toy that floats on a cushion of air over any smooth, flat surface.

A fan expels air from underneath the toy, allowing the toy to float a few millimetres above the surface, ensuring that the toy can move freely.



top view

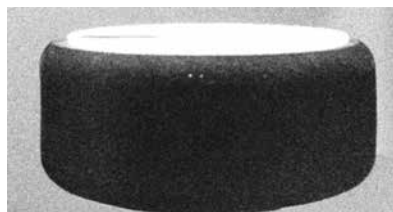

side view

(a) Explain how the action of the fan allows the toy to float a small distance above the surface.

(3)

.....

.....

.....

.....

.....

.....

.....

.....

*(b) A teacher uses two of the toys, A and B, in a demonstration. Toy A moves towards toy B, which is initially stationary. The two toys collide.

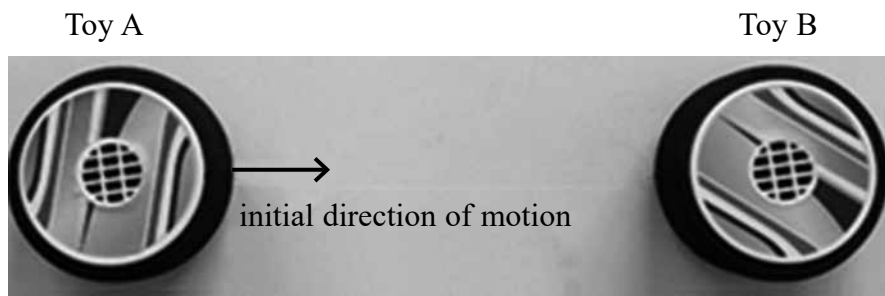

The teacher states ‘Applying Newton’s 2nd and 3rd laws of motion to this collision leads to the conclusion that momentum is conserved.’.

Justify this statement.

(6)

(Total for Question 18 = 9 marks)

19 A swing consists of a tyre suspended by nylon ropes of negligible mass as shown.

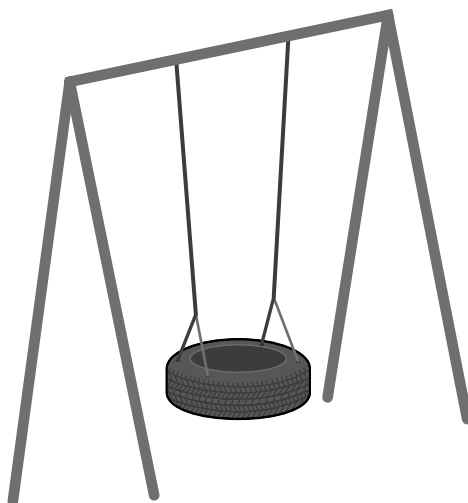

When pulled back slightly from its rest position and released, the tyre moves with simple harmonic motion.

(a) State what is meant by simple harmonic motion.

(2)

.....

.....

.....

.....

(b) The sketch graph shows how acceleration varies with time for the tyre.

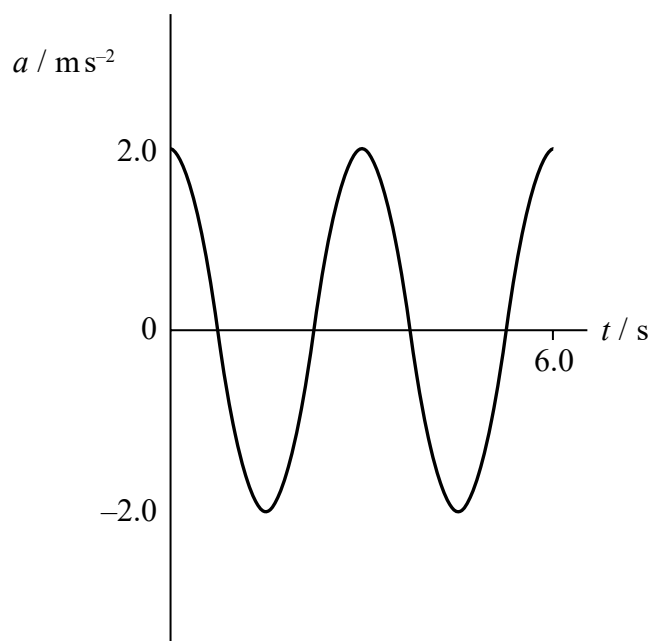

(i) Show that the amplitude of the motion is about 0.5 m.

(3)

.....

.....

.....

.....

.....

.....

.....

.....

(ii) Calculate the maximum velocity of the tyre.

(2)

.....

.....

.....

.....

.....

Maximum velocity of tyre =

(iii) Draw a line on the graph to show how the velocity of the tyre varies with time.

(2)

(Total for Question 19 = 9 marks)

DO NOT WRITE IN THIS AREA

DO NOT WRITE IN THIS AREA

DO NOT WRITE IN THIS AREA

20 A satellite of mass m is in orbit around the Earth. The radius of the orbit is r .

(a) (i) The gravitational field strength g at a distance r from the centre of the Earth is given by

$$g = \frac{GM}{r^2}$$

where M is the mass of the Earth.

Derive this equation.

(2)

.....

.....

.....

.....

.....

(ii) On an astrophysics website it states.

“For all satellites in a circular orbit

$$T^2 \propto r^3$$

where T is the period of the orbit and r is the radius of the orbit.”

Justify this statement.

(4)

.....

.....

.....

.....

.....

.....

.....

.....

.....

.....

- (b) Some satellites are in low Earth orbits. These orbits have a radius approximately equal to the radius of the Earth R_E . A satellite in a low Earth orbit has a time period of 88 minutes.

Some satellites are in a geostationary orbit. These satellites are always above the same point on the surface of the Earth.

- (i) Determine, using the expression in (a)(ii), the height of a satellite in a geostationary orbit.

$$R_E = 6.4 \times 10^6 \text{ m}$$

(3)

- (ii) Suggest why a satellite has to be over the equator to remain in a geostationary orbit.

(1)

(Total for Question 20 = 10 marks)

21 A Hertzsprung-Russell (HR) diagram shows the relationship between the luminosity and surface temperature of stars.

The positions of three stars and the Sun are indicated on the HR diagram shown.

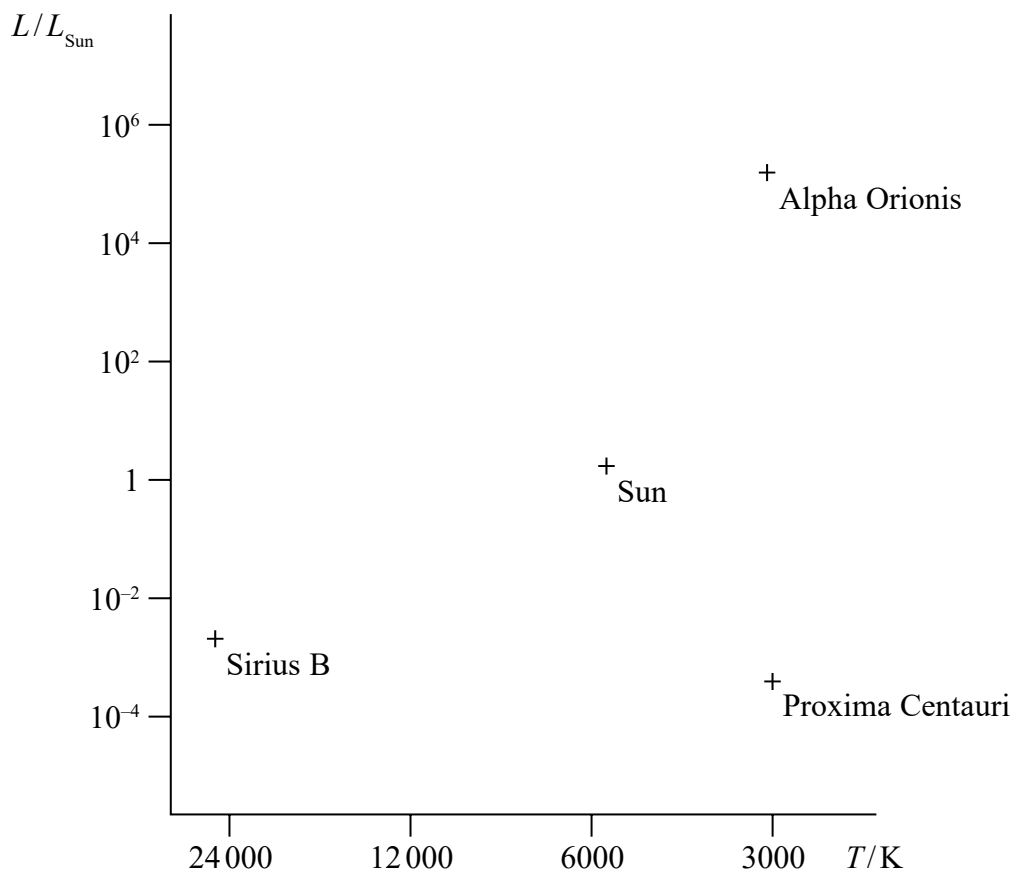

(a) The Sun is a main sequence star.

(i) State what is meant by a main sequence star.

(1)

(ii) Draw the main sequence region on the HR diagram above.

(1)

(b) On an astronomy website it states that:

“Alpha Orionis has a much smaller radius than Proxima Centauri. Both stars appear the same colour when viewed through a telescope.”

(i) Assess the validity of this statement.

(4)

.....

.....

.....

.....

.....

.....

.....

.....

.....

.....

.....

.....

.....

.....

.....

.....

.....

.....

.....

.....

.....

.....

.....

(ii) Explain the differences between Sirius B and Proxima Centauri.

(3)

.....

.....

.....

.....

.....

.....

.....

.....

.....

.....

.....

.....

.....

.....

.....

.....

.....

.....

.....

.....

.....

.....

.....

(Total for Question 21 = 9 marks)

TOTAL FOR SECTION B = 80 MARKS

TOTAL FOR PAPER = 90 MARKS

DO NOT WRITE IN THIS AREA

DO NOT WRITE IN THIS AREA

DO NOT WRITE IN THIS AREA

Every effort has been made to contact copyright holders to obtain their permission for the use of copyright material. Pearson Education Ltd. will, if notified, be happy to rectify any errors or omissions and include any such rectifications in future editions.

Unit 5: Thermodynamics, Radiation, Oscillations and Cosmology - Mark scheme

Question number	Answer	Mark
1	B	1
2	D	1
3	B	1
4	C	1
5	D	1
6	C	1
7	D	1
8	A	1
9	D	1
10	B	1

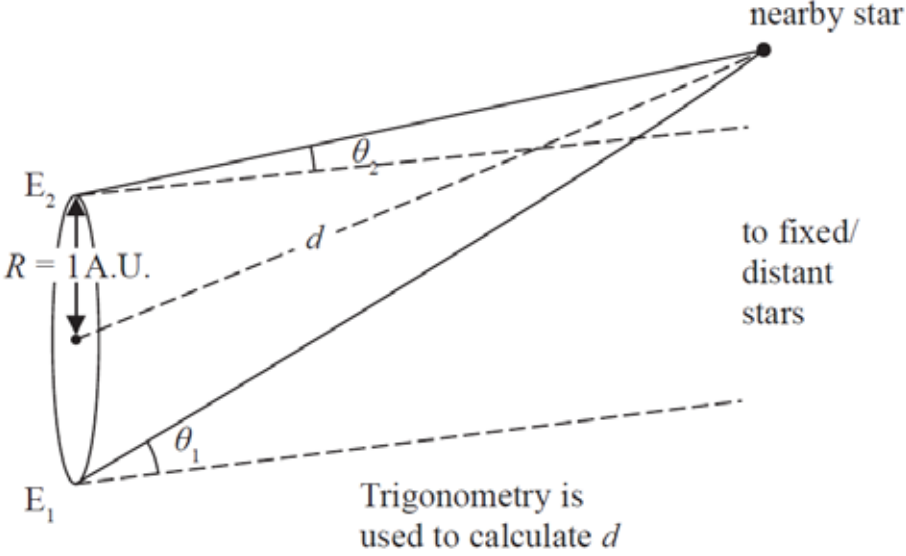
Question number	Answer	Mark
11	<ul style="list-style-type: none"> • The star is viewed from two positions at 6-month intervals Or The star is viewed from opposite ends of the Earth's orbit diameter about the Sun (1) • The change in angular position of the star against backdrop of fixed stars is measured (1) • Trigonometry is used to calculate the distance (to the star) [Do not accept Pythagoras] Or The diameter/radius of the Earth's orbit about the Sun must be known Or The distance to the Sun is 1AU (1) <p>Full marks may be obtained from a suitably annotated diagram, e.g.</p>  <p>[Accept the symmetrical diagram seen in many textbooks]</p>	3
Total for Question 11		3

Question number	Answer	Mark
12(a)	<ul style="list-style-type: none"> Use of $\Delta E = mc\Delta\theta$ (1) Use of $P = \frac{\Delta W}{\Delta t}$ (1) Time taken = 130 s (1) <p><u>Example of calculation</u></p> $\Delta E = 3 \times 0.325 \text{ kg} \times 4190 \text{ J kg}^{-1} \text{ K}^{-1} \times (100 - 8.5) \text{ K} = 373\,800 \text{ J}$ $\Delta t = \frac{373\,800 \text{ J}}{2.80 \times 10^3 \text{ W}} = 134 \text{ s}$	3
12(b)	<ul style="list-style-type: none"> Use of $\Delta E = L\Delta m$ (1) Difference between power input and useful power calculated (1) Rate of thermal energy transfer to surroundings = 340 W (1) <p><u>Example of calculation</u></p> $\frac{\Delta E}{\Delta t} = 2.26 \times 10^6 \text{ J kg}^{-1} \times \frac{0.136 \text{ kg}}{125 \text{ s}} = 2460 \text{ W}$ <p>Rate of thermal energy transfer to surroundings = 2800 W – 2460 W = 340 W</p>	3
Total for Question 12		6

Question number	Answer	Mark
13(a)	<ul style="list-style-type: none"> α correct (1) (1) Th correct (1) (1) ${}_{92}^{238}\text{U} \rightarrow {}_{90}^{234}\text{Th} + \frac{4}{2}\alpha$	2
13(b)(i)	<ul style="list-style-type: none"> Use of $A = -\lambda N$ (1) Use of $\lambda = \frac{\ln 2}{t_{1/2}}$ (1) $N = 7.47 \times 10^{18}$ (1) <p><u>Example of calculation</u></p> $\lambda = \frac{\ln 2}{1.41 \times 10^{17} \text{ s}} = 4.91 \times 10^{-18} \text{ s}^{-1}$ $36.7 \text{ s}^{-1} = -4.91 \times 10^{-18} \text{ s}^{-1} \times N$ $\therefore N = \frac{36.7 \text{ s}^{-1}}{4.91 \times 10^{-18} \text{ s}^{-1}} = 7.47 \times 10^{18}$	3

Question number	Answer	Mark
13(b)(ii)	<ul style="list-style-type: none"> The decay products are radioactive Or the background radiation should be subtracted from the recorded count rate <p style="text-align: right;">(1)</p>	1
	Total for Question 13	6

Question number	Answer	Mark
14(a)	<ul style="list-style-type: none"> Use of $pV = NkT$ (1) Conversion of temperature from °C to K (1) $N = 3.82 \times 10^{23}$ (1) <p><u>Example of calculation</u></p> $N = \frac{1.10 \times 10^5 \text{ Pa} \times 0.0142 \text{ m}^3}{1.38 \times 10^{-23} \text{ J K}^{-1} \times (23.5 + 273) \text{ K}} = 3.82 \times 10^{23}$	3
14(b)	<p>If the temperature of the helium gas is increased then</p> <ul style="list-style-type: none"> The pressure exerted by the helium inside the balloon increases (1) (so the volume of the balloon will increase) until the pressure exerted by the helium equals the external air pressure (1) 	2
	Total for Question 14	5

Question number	Answer	Mark
15(a)	<p>The binding energy is:</p> <ul style="list-style-type: none"> The energy released when the nucleons come together to form the nucleus Or The energy required to split the nucleus up into its component nucleons 	(1)
15(b)(i)	<ul style="list-style-type: none"> Calculation of mass difference in kg Use of $\Delta E = c^2\Delta m$ Conversion from kg into MeV $\Delta E = 8.5 \text{ MeV}$ <p><u>Example of calculation</u></p> $\Delta m = (1.00728 + [2 \times 1.00867] - 3.01551)\text{u} \times 1.66 \times 10^{-27}\text{kg}$ $\therefore \Delta m = 1.51 \times 10^{-29} \text{ kg}$ $\Delta E = (3 \times 10^8 \text{ m s}^{-1})^2 \times 1.51 \times 10^{-29}\text{kg} = 1.36 \times 10^{-12}\text{J}$ $\Delta E = \frac{1.36 \times 10^{-12}\text{J}}{1.6 \times 10^{-13}\text{J MeV}^{-1}} = 8.49 \text{ MeV}$	(1) (1) (1) (1)
15(b)(ii)	<ul style="list-style-type: none"> When massive nuclei undergo fusion the binding energy per nucleon decreases Hence energy must be supplied in order for fusion to proceed 	(1) (1)
Total for Question 15		7

Question number	Answer	Mark
16(a)	<ul style="list-style-type: none"> Use of $L = 4\pi r^2\sigma T^4$ $r = 6.9 \times 10^8 \text{ m}$ <p><u>Example of calculation</u></p> $r = \sqrt[4]{\frac{3.85 \times 10^{26}\text{W}}{4\pi \times 5.67 \times 10^{-8}\text{W m}^{-2}\text{K}^{-4} \times (5800)^4}} = 6.91 \times 10^8\text{m}$	(1) (1)
16(b)	<ul style="list-style-type: none"> Use of $I = \frac{L}{4\pi d^2}$ Use of fraction dissipated Use of efficiency = $\frac{\text{useful power out}}{\text{total power input}}$ Use of $I = \frac{P}{A}$ $P = 56 \text{ MW}$ <p><u>Example of calculation</u></p> $I = \frac{3.85 \times 10^{26}\text{W}}{4\pi \times (1.50 \times 10^{11}\text{m})^2} = 1360 \text{ W m}^{-2}$ $P = 1360 \text{ W m}^{-2} \times (1-0.25) \times 0.22 \times 250\,000 \text{ m}^2 = 5.61 \times 10^7 \text{ W}$	(1) (1) (1) (1) (1)
Total for Question 16		7

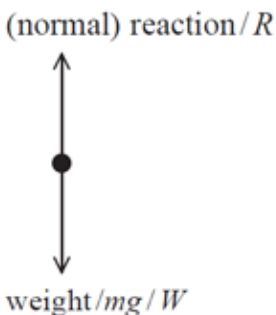
Question number	Answer	Mark
17(a)	Resonance	(1) 1
17(b)	<ul style="list-style-type: none"> • Use of $f = \frac{n}{t}$ • Use of $\omega = 2\pi f$ • Use of $a = -\omega^2 x$ • $a = 14 \text{ m s}^{-2}$ <p><u>Example of calculation</u></p> $f = \frac{38}{60 \text{ s}} = 0.633 \text{ s}^{-1}$ $\omega = 2\pi \times 0.633 \text{ s}^{-1} = 3.98 \text{ rad s}^{-1}$ $a = -(3.98 \text{ rad s}^{-1})^2 \times 0.90 \text{ m} = 14.3 \text{ m s}^{-2}$	(1) (1) (1) (1) 4
17(c)(i)	<ul style="list-style-type: none"> • Both forces drawn and labelled <p><u>Example of diagram</u></p> 	(1) 1
17(c)(ii)	<ul style="list-style-type: none"> • There must always be an acceleration towards the equilibrium position • Or there must always be a resultant force towards the equilibrium position • (Applying Newton's 2nd law) $W - R = ma$ • so $R = W - ma$ • If $a \geq g$, then $R = 0$ and so car will lose contact with the road 	(1) (1) (1) 3
Total for Question 17		9

Question number	Answer	Mark																				
18(a)	<ul style="list-style-type: none"> The fan in the toy pushes the air molecules downwards (1) According to Newton's 3rd law, toy is pushed upwards by the air molecules (1) The upward force balances the weight of the toy (1) 	3																				
18(b)	<p>This question assesses a student's ability to show a coherent and logically structured answer with linkages and fully-sustained reasoning. Marks are awarded for indicative content and for how the answer is structured and shows lines of reasoning. The following table shows how the marks should be awarded for indicative content.</p> <table border="1"> <thead> <tr> <th>Number of indicative marking points seen in answer</th> <th>Number of marks awarded for indicative marking points</th> </tr> </thead> <tbody> <tr> <td>6</td> <td>4</td> </tr> <tr> <td>5-4</td> <td>3</td> </tr> <tr> <td>3-2</td> <td>2</td> </tr> <tr> <td>1</td> <td>1</td> </tr> <tr> <td>0</td> <td>0</td> </tr> </tbody> </table> <p>The following table shows how the marks should be awarded for structure and lines of reasoning.</p> <table border="1"> <thead> <tr> <th></th> <th>Number of marks awarded for structure of answer and sustained line of reasoning</th> </tr> </thead> <tbody> <tr> <td>Answer shows a coherent and logical structure with linkages and fully sustained lines of reasoning demonstrated throughout</td> <td>2</td> </tr> <tr> <td>Answer is partially structured with some linkages and lines of reasoning</td> <td>1</td> </tr> <tr> <td>Answer has no linkages between points and is unstructured</td> <td>0</td> </tr> </tbody> </table> <p>Total marks awarded is the sum of marks for indicative content and the marks for structure and lines of reasoning</p> <p>Indicative content</p> <ul style="list-style-type: none"> applying Newton's 3rd law, toy A exerts a force on toy B and vice versa forces equal in magnitude and opposite in direction forces act for same time $F\Delta t_A = -F\Delta t_B$ applying Newton's 2nd law $F\Delta t = \Delta p$ total momentum change = 0, so momentum conserved Or Δp for one toy = $-\Delta p$ for the other toy, so momentum is conserved 	Number of indicative marking points seen in answer	Number of marks awarded for indicative marking points	6	4	5-4	3	3-2	2	1	1	0	0		Number of marks awarded for structure of answer and sustained line of reasoning	Answer shows a coherent and logical structure with linkages and fully sustained lines of reasoning demonstrated throughout	2	Answer is partially structured with some linkages and lines of reasoning	1	Answer has no linkages between points and is unstructured	0	6
Number of indicative marking points seen in answer	Number of marks awarded for indicative marking points																					
6	4																					
5-4	3																					
3-2	2																					
1	1																					
0	0																					
	Number of marks awarded for structure of answer and sustained line of reasoning																					
Answer shows a coherent and logical structure with linkages and fully sustained lines of reasoning demonstrated throughout	2																					
Answer is partially structured with some linkages and lines of reasoning	1																					
Answer has no linkages between points and is unstructured	0																					
	Total for Question 18	9																				

Question number	Answer	Mark
19(a)	<p>For simple harmonic motion the acceleration of the tyre is:</p> <ul style="list-style-type: none"> • directly proportional to displacement from equilibrium position (1) • always acting towards the equilibrium position (1) <p>Or idea that acceleration is in the opposite direction to displacement (1)</p> <p>[Accept definition in terms of force]</p>	2
19(b)(i)	<ul style="list-style-type: none"> • Use of $\omega = \frac{2\pi}{T}$ with $T = 3$ s (1) • Use of $a = -\omega^2 x$ (1) • $A = 0.46$ m (1) <p><u>Example of calculation</u></p> $\omega = \frac{2\pi}{6.0 \text{ s}/2} = 2.09 \text{ rad s}^{-1}$ $A = \frac{2 \text{ m s}^{-2}}{(2.09 \text{ rad s}^{-1})^2} = 0.456 \text{ m}$	3
19(b)(ii)	<ul style="list-style-type: none"> • Use of $v = A\omega \sin \omega t$ (1) • $v = 0.95 \text{ m s}^{-1}$ (allow e.c.f. ω and A from b(i)) (1) <p><u>Example of calculation</u></p> $v = 0.456 \text{ m} \times 2.09 \text{ rad s}^{-1} = 0.953 \text{ m s}^{-1}$	2

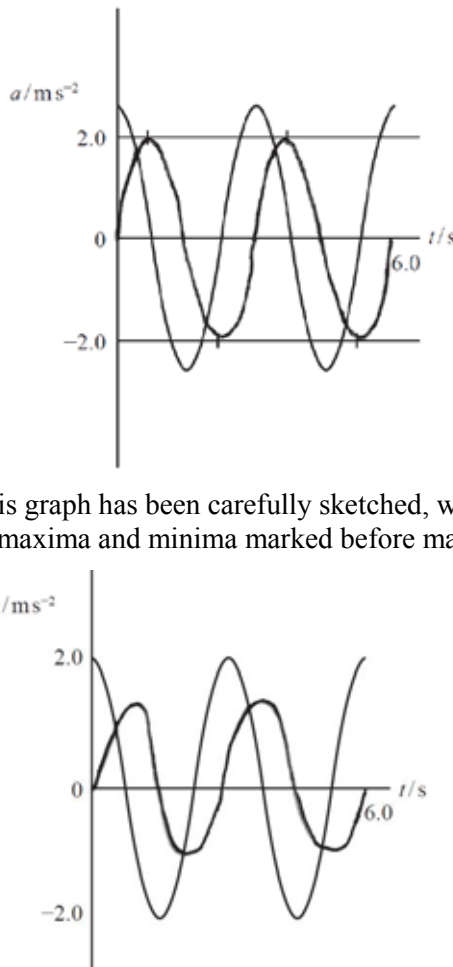
Question number	Answer	Mark
19(b)(iii)	<ul style="list-style-type: none"> • Sine curve drawn with correct shape and time period of 3 s (1) • Constant amplitude [any size] (MP2 dependent upon MP1) (1) <p>Examples of graphs:</p>  <p>This graph has been carefully sketched, with construction lines and positions of maxima and minima marked before making the freehand graph sketch.</p> <p>This graph has been sketched without the aid of construction lines. Positions of maxima and minima have not been marked. The maxima are slightly displaced from their correct positions, although the shape is generally good and the amplitude is constant.</p>	2
Total for Question 19		9

Question number	Answer	Mark
20(a)(i)	<ul style="list-style-type: none"> States $F = \frac{GMm}{r^2}$ (1) $mg = \frac{GMm}{r^2}$ leading to $g = \frac{GM}{r^2}$ (1) 	2
20(a)(ii)	<ul style="list-style-type: none"> $g = \frac{GM}{r^2}$ combined with $a = r\omega^2$ Or $F = \frac{GMm}{r^2}$ combined with $F = mr\omega^2$ (1) <p>(accept equations in terms of v or ω)</p> <ul style="list-style-type: none"> Use of $\omega = \frac{2\pi}{T}$ Or $v = \frac{2\pi r}{T}$ (1) Maths to show $T^2 = \frac{4\pi^2 r^3}{GM}$ (1) π, G and M identified as being constant, so $T^2 \propto r^3$ (1) <p><u>Example of derivation</u></p> $\frac{GM}{r^2} = r\omega^2 = r\left(\frac{2\pi}{T}\right)^2$ $\therefore \frac{GM}{r^2} = \frac{4\pi^2 r}{T^2}$ $\therefore T^2 = \frac{4\pi^2 r^3}{GM}$ $\therefore T^2 \propto r^3$	4
20(b)(i)	<ul style="list-style-type: none"> $T = 24$ hours for a geostationary orbit (1) Use of $T^2 \propto r^3$ (1) $h = 3.5 \times 10^7$ m (1) <p><u>Example of calculation</u></p> $\frac{T_1^2}{T_2^2} = \frac{r_1^3}{r_2^3}$ $\therefore r_2 = \sqrt[3]{\frac{(24 \times 60 \text{ min})^2}{(88 \text{ min})^2}} \times 6.4 \times 10^6 \text{ m} = 4.13 \times 10^7 \text{ m}$ $\therefore h = 4.13 \times 10^7 \text{ m} - 6.4 \times 10^6 \text{ m} = 3.49 \times 10^7 \text{ m}$	3
20(b)(ii)	<ul style="list-style-type: none"> Idea that there must be a common axis of rotation for the satellite and the Earth Or the plane of the satellite's orbit must be at right angles to the spin axis of the Earth (1) 	1
Total for Question 20		10

Question number	Answer	Mark
21(a)(i)	<ul style="list-style-type: none"> A main sequence star is fusing/burning hydrogen in its core (1) 	1
21(a)(i)	<ul style="list-style-type: none"> Diagonal region from top left to bottom right to include the Sun and Proxima Centauri (1) <p><u>Example of diagram</u></p> <p>The diagram is a plot of luminosity relative to the Sun (L/L_{Sun}) on the vertical axis versus surface temperature (T/K) on the horizontal axis. The vertical axis is logarithmic, with major ticks at 10^6, 10^4, 10^2, 1, 10^{-2}, and 10^{-4}. The horizontal axis is linear, with major ticks at 24000, 12000, 6000, and 3000 K. A diagonal line, representing the main sequence, slopes downwards from left to right. Four stars are marked with '+' symbols: Alpha Orionis is at the top right of the main sequence; the Sun is on the main sequence; Sirius B is at the bottom left, off the main sequence; and Proxima Centauri is at the bottom right, also off the main sequence.</p>	1
21(b)(i)	<ul style="list-style-type: none"> Alpha Orionis and Proxima Centauri both have a surface temperature of about 3000 K (1) So according to Wien's law ($\lambda_{\text{max}}T = 2.9 \times 10^{-3}$) both will emit em-radiation that peaks in the same region of the spectrum (1) Alpha Orionis has a much greater luminosity than Proxima Centauri (1) According to Stefan's law ($L = 4\pi r^2 \sigma T^4$) so Alpha Orionis must have a much larger radius than Proxima Centauri hence the statement is not valid (1) 	4
21(b)(ii)	<ul style="list-style-type: none"> Sirius B is off the main sequence, has a much higher surface temperature but about the same luminosity as Proxima Centauri (1) So hydrogen fusion has ceased in the core of Sirius B whereas it hasn't for Proxima Centauri (1) Since Sirius B is much hotter but about the same luminosity this means it must have a much smaller radius than Proxima Centauri (1) 	3
	Total for Question 21	9

Write your name here

Surname

Other names

**Pearson Edexcel
International
Advanced Level**

Centre Number

--	--	--	--	--	--

Candidate Number

--	--	--	--	--

Physics

**International Advanced Level
Unit 6: Practical Skills in Physics II**

Sample Assessment Materials for first teaching September 2018

Time: 1 hour 20 minutes

Paper Reference

WPH16/01

You must have:

Scientific calculator, Ruler

Total Marks

Instructions

- Use **black** ink or **black** ball-point pen.
- **Fill in the boxes** at the top of this page with your name, centre number and candidate number.
- Answer **all** questions.
- Answer the questions in the spaces provided – *there may be more space than you need.*
- **Show all your working out in calculations and include units where appropriate.**

Information

- The total mark for this paper is 50.
- The marks for **each** question are shown in brackets – *use this as a guide as to how much time to spend on each question.*

Advice

- Read each question carefully before you start to answer it.
- Try to answer every question.
- Check your answers if you have time at the end.

Turn over ►

S58685A

©2018 Pearson Education Ltd.

1/1/1/1



Pearson

Answer ALL questions.

- 1 A student is asked to determine the density of the steel used to make a ball bearing.
The diameter of the ball bearing is measured across three different places using vernier calipers.

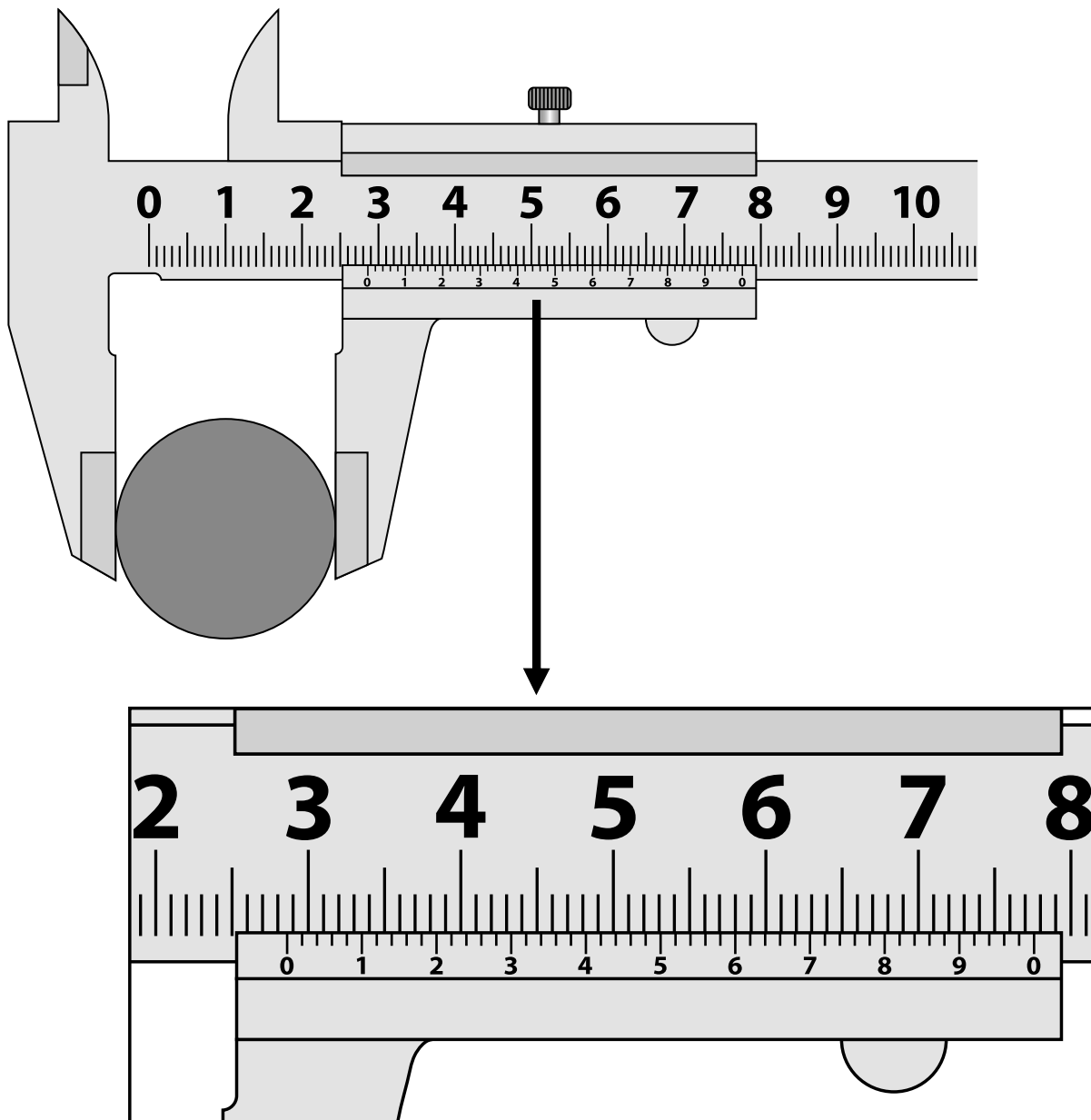

- (a) Read the measurement shown on the calipers.

Add the reading to the table below.

(1)

	Reading 1	Reading 2	Reading 3
Diameter/cm	2.854	2.861	

(b) Calculate the mean value for the diameter of the ball bearing.

(1)

Mean value for diameter =

(c) The mass of the ball bearing is measured as 98.00 g with negligible uncertainty.

Calculate the density of the steel.

(3)

Density =

(d) Calculate the percentage uncertainty in the value of density in (c).

(2)

Percentage uncertainty =

(Total for Question 1 = 7 marks)

2 A student investigated momentum. He set up the apparatus as shown.

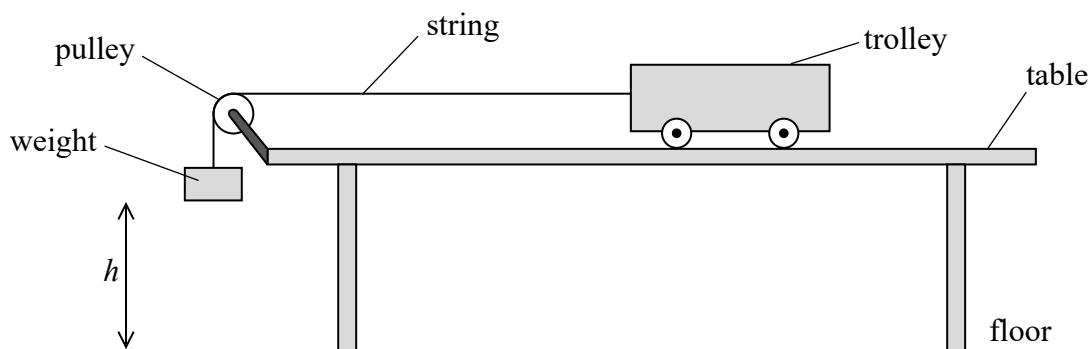

The trolley started from rest with the weight close to the pulley and at a height h above the floor.

(a) Add to the diagram to show how the height h should be measured.

(1)

(b) The student recorded h as 885 mm. He recorded the time t for the weight to fall through h and repeated this several times. His measurements are shown below.

t/s					Mean t/s
2.94	2.76	3.28	3.15	3.02	3.0

(i) The mean t has been recorded to two significant figures.

Explain why this is the appropriate number of significant figures in this case.

(2)

.....

.....

.....

.....

(ii) The maximum velocity v of the trolley is given by

$$v = \frac{2h}{t}$$

Calculate v .

(1)

$v =$

(iii) Calculate a value for the maximum momentum of the trolley and falling weight.

mass of trolley = 0.930 kg

mass of falling weight = 0.030 kg

(1)

Maximum momentum =

(c) An equation that includes momentum is $F\Delta t = \Delta p$.

(i) Use this equation to calculate the maximum momentum of the trolley and falling weight.

(1)

Maximum momentum =

(ii) Suggest why you would **not** expect the maximum momentum in (b)(iii), calculated from the student's results, to be the same as the value calculated in (c)(i).

(1)

(Total for Question 2 = 7 marks)

- 3 A student determines the specific heat capacity of aluminium. She uses a block of aluminium that has holes in it designed to take an electric heater and a thermometer.

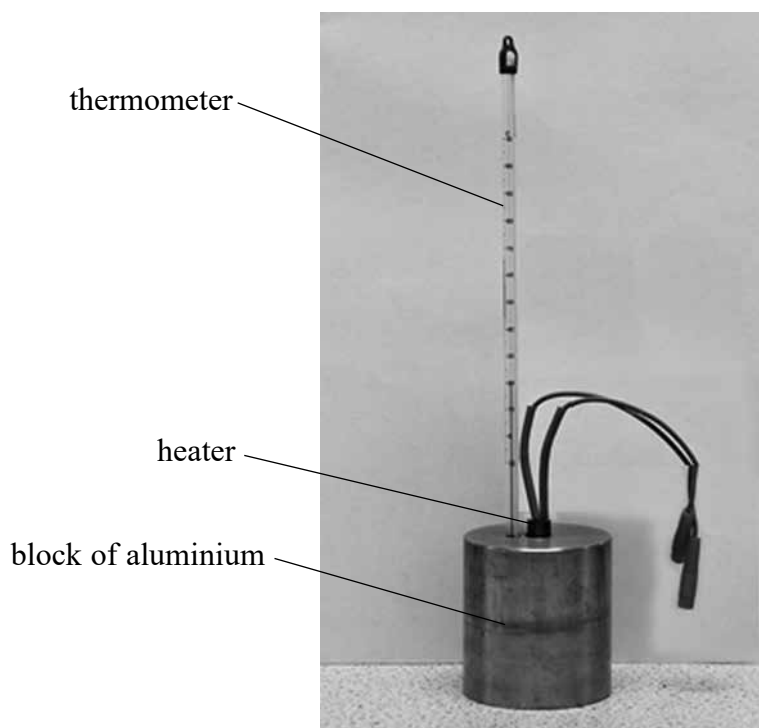

She puts the block of aluminium in a freezer until its temperature is 10°C below room temperature. She then heats the block of aluminium until its maximum temperature is 10°C above room temperature.

- (a) Write a plan for this experiment.

You should include

- a circuit diagram
- a description of the measurements you would take
- how you would use the data obtained.

(5)

.....

.....

.....

.....

.....

.....

.....

.....

.....

.....

DO NOT WRITE IN THIS AREA

DO NOT WRITE IN THIS AREA

DO NOT WRITE IN THIS AREA

- (b) The student cooled the block and then heated it to above room temperature to improve the accuracy of the experiment.

Explain why this would improve the accuracy of the experiment.

(2)

(Total for Question 3 = 7 marks)

- 4 A coil with an iron core was connected to an a.c. power supply. A second coil with an iron core was connected to a voltmeter as shown. The meter displayed the induced potential difference V , in volts, across the second coil.



The student investigated the effect of inserting aluminium between the coils. The student inserted an aluminium plate in the gap between the coils and recorded the new reading V on the voltmeter. She repeated this for varying thicknesses t of aluminium.

t/mm	V/V
0	0.44
1.50	0.41
3.5	0.38
5.51	0.35
6.72	0.33
8.22	0.31

- (a) (i) Criticise the recording of this data.

(2)

.....

.....

.....

.....

(ii) State two variables that would need to be controlled in this investigation. (2)

.....

.....

(iii) State the resolution of the voltmeter as shown in the diagram. (1)

.....

(iv) The resolution of the voltmeter can be changed so the display shows fewer or more significant figures. The student changed the number of significant figures shown on the voltmeter from three to two, as shown in the photograph.

Suggest why this might have been a sensible change to make. (1)

.....

.....

(v) The student states that the readings for V are precise.
Explain why this is **not** correct. (2)

.....

.....

.....

.....

(b) (i) The student suggests that the results show that V is inversely proportional to t .
State why this suggestion cannot be true. Your answer does **not** require a calculation. (1)

.....

.....

DO NOT WRITE IN THIS AREA

(ii) Another student suggests that the relationship is of the form

$$V = V_0 e^{-bt}$$

where b is a constant.

Describe how you would test this suggestion graphically.

(2)

.....

.....

.....

.....

.....

(Total for Question 4 = 11 marks)

DO NOT WRITE IN THIS AREA

DO NOT WRITE IN THIS AREA

DO NOT WRITE IN THIS AREA

DO NOT WRITE IN THIS AREA

DO NOT WRITE IN THIS AREA

DO NOT WRITE IN THIS AREA

BLANK PAGE

5 A teacher demonstrated how the intensity of gamma rays varied with distance from a source.

(a) Describe an experiment to confirm that the source emits gamma radiation.

(3)

.....

.....

.....

.....

.....

.....

(b) Describe two safety precautions that should be taken when using radioactive sources.

(2)

.....

.....

.....

(c) The teacher used the set-up shown below.

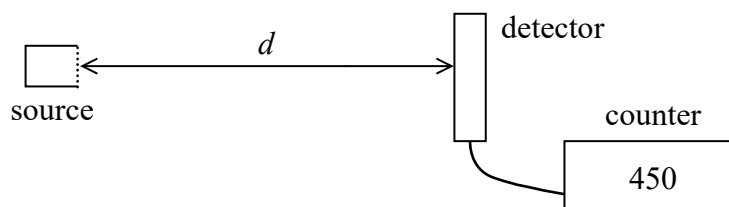

The teacher measured the distance d from the source to the detector and the corresponding count during a time t . Her results are shown in the table below.

d / cm	Count	t / s
5.0	1163	30
6.0	897	30
7.0	586	30
9.0	793	60
11.0	559	60
13.0	469	60

- (i) The teacher decided to change the period for the count rate from 30 s to 60 s as the distance between the source and detector became greater.

Give a reason why this was appropriate.

(1)

- (ii) The teacher initially increased d by intervals of 1 cm then increased the interval to 2 cm.

Give a reason why this was appropriate.

(1)

DO NOT WRITE IN THIS AREA

DO NOT WRITE IN THIS AREA

DO NOT WRITE IN THIS AREA

(d) The relationship between d and the count rate C is given by

$$d = \frac{k}{\sqrt{C}} - x$$

where k and x are constants.

(i) Plot a suitable graph on the grid opposite to show that these data are consistent with this relationship. Use the additional columns for your processed data.

background count rate = 58 counts minute⁻¹

d / cm	Count	Time for count/s				
5.0	1163	30				
6.0	897	30				
7.0	586	30				
9.0	793	60				
11.0	559	60				
13.0	469	60				

(8)

(ii) Use your graph to determine the values of k and x .

(3)

$k =$

$x =$

DO NOT WRITE IN THIS AREA

DO NOT WRITE IN THIS AREA

DO NOT WRITE IN THIS AREA

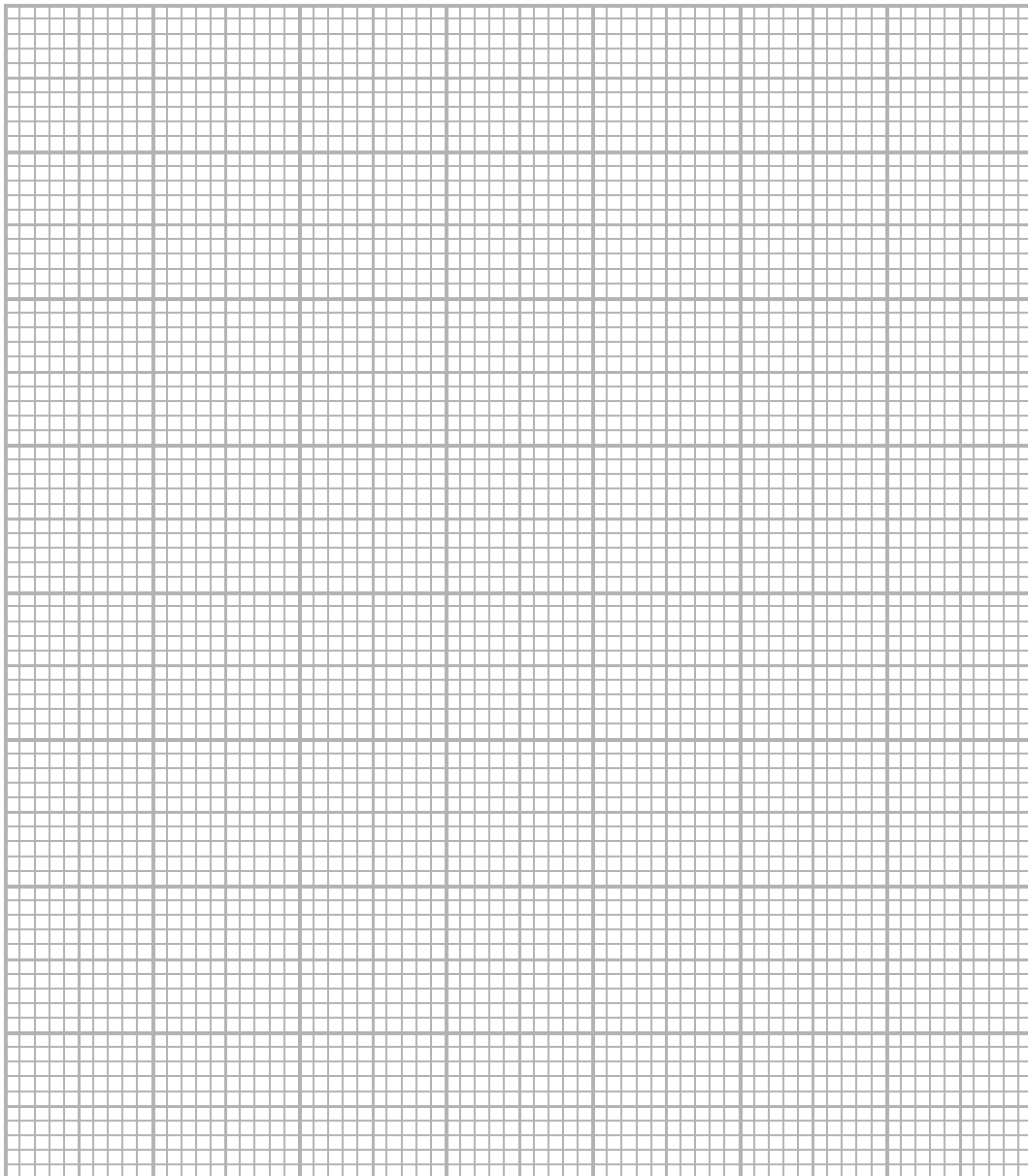

(Total for Question 5 = 18 marks)

TOTAL FOR PAPER = 50 MARKS

DO NOT WRITE IN THIS AREA

DO NOT WRITE IN THIS AREA

DO NOT WRITE IN THIS AREA

BLANK PAGE

Unit 6: Practical Skills in Physics II - Mark scheme

Question number	Answer	Mark
1(a)	• 2.860 (1)	1
1(b)	• 2.858 cm (four sig figs. Allow ecf from (a)) (1)	1
1(c)	<ul style="list-style-type: none"> • Use of $V = \frac{4\pi r^3}{3}$ (1) • Use of $\rho = \frac{m}{V}$ (1) • Density = 8.020 g cm⁻³ must be to 4 SF allow ecf from (b) (1) <p><u>Example of calculation</u></p> $V = \frac{4\pi 1.429^3 \text{ cm}^3}{3} = 12.223 \text{ cm}^3$ $\rho = \frac{98.00\text{g}}{12.223\text{cm}^3} = 8.018 \text{ g cm}^{-3}$	3
1(d)	<ul style="list-style-type: none"> • Calculates % uncertainty in diameter from (b) (1) • % uncertainty in density = 0.4 (accept 0.42 or 0.37 if half-range is used) (1) <p><u>Example of calculation</u></p> <p>Uncertainty in diameter = 2.858-2.854 = 0.004 % uncertainty in diameter = 0.004/2.858 × 100 = 0.14% % uncertainty in volume and density = 3 × 0.14 = 0.42</p>	2
	Total for Question 1	7

Question number	Answer	Mark
2(a)	<ul style="list-style-type: none"> metre rule shown vertical with set square on floor 	(1) 1
2(b)(i)	<ul style="list-style-type: none"> The resolution of the stopwatch is 0.01 seconds But there is a human reaction time when starting and stopping the stopwatch 	(1) 2 (1)
2(b)(ii)	<ul style="list-style-type: none"> $v = 0.59 \text{ m s}^{-1}$ <p><u>Example of calculation</u> $v = \frac{2h}{t} = 2 \times 0.885/3.0$ $v = 0.59 \text{ m s}^{-1}$</p>	(1) 1
2(b)(iii)	<ul style="list-style-type: none"> Calculates value of momentum <p><u>Example of calculation</u> $P = 0.96 \text{ kg} \times 0.59 \text{ m s}^{-1} = 0.57 \text{ kg m s}^{-1}$</p>	(1) 1
2(c)(i)	<ul style="list-style-type: none"> Momentum = 0.88 kg m s^{-1} <p><u>Example of calculation</u> $\Delta p = 0.030 \times 9.81 \times 3.0$ $= 0.88 \text{ kg m s}^{-1}$</p>	(1) 1
2(c)(ii)	<ul style="list-style-type: none"> External forces acting Or friction acting 	(1) 1
	Total for Question 2	7

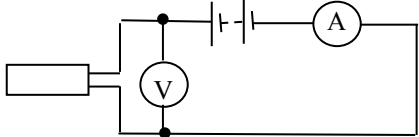
Question number	Answer	Mark
3(a)	<ul style="list-style-type: none"> • Circuit showing power supply unit (psu), heater, ammeter in series and voltmeter in parallel with heater (1) • Measure the p.d., current and mass of block (and heater) (1) • Measure initial and final temperature and corresponding time interval (1) • Use of $E = VIt$ (1) • Use of $c = \Delta E / m \Delta\theta$ (1) <p><u>Example of circuit</u></p> 	5
3(b)	<ul style="list-style-type: none"> • Not all energy from the heater is supplied to the block Or some energy transferred to/from surroundings (1) • energy transfer to cancels/equals energy transfer from the surroundings (by using same temperature difference below/above surroundings) (1) 	2
Total for Question 3		7

Question number	Answer	Mark
4(a)(i)	<ul style="list-style-type: none"> • 3.5 mm should have the same number of SF as other values in column (1) • There are no repeat readings (1) 	2
4(a)(ii)	Any two from <ul style="list-style-type: none"> • Distance between coils (1) • Potential difference (across first coil) power supply (1) • Frequency of ac supply (1) 	2
4(a)(iii)	<ul style="list-style-type: none"> • 0.01 V (1) 	1
4(a)(iv)	<ul style="list-style-type: none"> • Because the final digit fluctuates (1) 	1
4(a)(v)	<ul style="list-style-type: none"> • Would need to take some repeat readings (1) • Consider how close together in value (1) 	2
4(b)	<ul style="list-style-type: none"> • There is a value of V when $t = 0$ (1) 	1
4(c)	<ul style="list-style-type: none"> • Plot $\ln V$ against t (1) • Should be a straight-line graph if the relationship is exponential (1) 	2
	Total for Question 4	11

Question number	Answer	Mark																																																	
5(a)	<ul style="list-style-type: none"> Record background count (rate) (1) Place thick aluminium/thin lead between source and detector (1) Or Distance greater than 25 cm between source and detector (1) Count rate detected above background (1) 	3																																																	
5(b)	Any two from <ul style="list-style-type: none"> Point source away from people (1) Invert source within lead container (1) Use tongs to handle source (1) Use tongs to handle lead sheets/ensure source held (1) 	2																																																	
5(c)(i)	<ul style="list-style-type: none"> The count is a large number for small distances so percentage errors will be smaller (1) 	1																																																	
5(c)(ii)	<ul style="list-style-type: none"> There is a larger variation in count over smaller distances (1) 	1																																																	
5(d)(i)	<ul style="list-style-type: none"> Calculates count rate per minute or per second or per 30 s (1) Subtract background count (1) Count rate $C^{-1/2}$ to at least 3SF (1) Axes labelled for suitable graph and with correct units (1) Suitable scales (1) Points plotted (1) Line of best fit (1) <p><u>Example of table</u></p> <table border="1"> <thead> <tr> <th>d / cm</th> <th>Count</th> <th>Time for count / s</th> <th>$C \text{ min}^{-1}$</th> <th>C-background min^{-1}</th> <th>$C^{0.5} / \text{min}^{-0.5}$</th> <th>$C^{-0.5} / \text{min}^{0.5}$</th> </tr> </thead> <tbody> <tr> <td>5</td> <td>1163</td> <td>30</td> <td>2326</td> <td>2268</td> <td>47.62352</td> <td>0.0210</td> </tr> <tr> <td>6</td> <td>897</td> <td>30</td> <td>1794</td> <td>1736</td> <td>41.66533</td> <td>0.0240</td> </tr> <tr> <td>7</td> <td>586</td> <td>30</td> <td>1172</td> <td>1114</td> <td>33.37664</td> <td>0.0300</td> </tr> <tr> <td>9</td> <td>793</td> <td>60</td> <td>793</td> <td>735</td> <td>27.11088</td> <td>0.0369</td> </tr> <tr> <td>11</td> <td>559</td> <td>60</td> <td>559</td> <td>501</td> <td>22.38303</td> <td>0.0447</td> </tr> <tr> <td>13</td> <td>469</td> <td>60</td> <td>469</td> <td>411</td> <td>20.27313</td> <td>0.0493</td> </tr> </tbody> </table>	d / cm	Count	Time for count / s	$C \text{ min}^{-1}$	C-background min^{-1}	$C^{0.5} / \text{min}^{-0.5}$	$C^{-0.5} / \text{min}^{0.5}$	5	1163	30	2326	2268	47.62352	0.0210	6	897	30	1794	1736	41.66533	0.0240	7	586	30	1172	1114	33.37664	0.0300	9	793	60	793	735	27.11088	0.0369	11	559	60	559	501	22.38303	0.0447	13	469	60	469	411	20.27313	0.0493	7
d / cm	Count	Time for count / s	$C \text{ min}^{-1}$	C-background min^{-1}	$C^{0.5} / \text{min}^{-0.5}$	$C^{-0.5} / \text{min}^{0.5}$																																													
5	1163	30	2326	2268	47.62352	0.0210																																													
6	897	30	1794	1736	41.66533	0.0240																																													
7	586	30	1172	1114	33.37664	0.0300																																													
9	793	60	793	735	27.11088	0.0369																																													
11	559	60	559	501	22.38303	0.0447																																													
13	469	60	469	411	20.27313	0.0493																																													

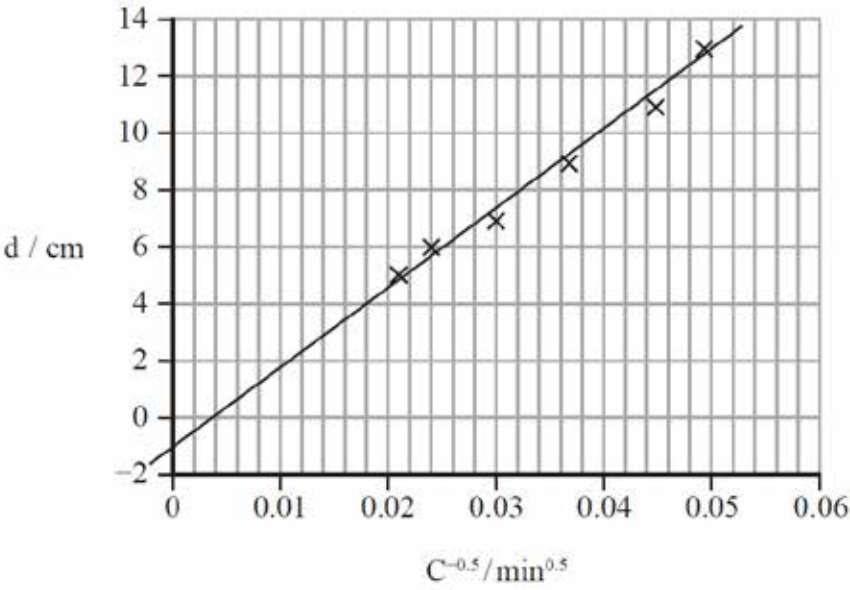
		
5(d)(ii)	<ul style="list-style-type: none"> • Use of large triangle to determine gradient (1) • $k = 280$ (allow 260 – 300) (1) • Unit: $\text{cm min}^{-0.5}$ (1) • x (y intercept) = 1.0 cm (allow 0.6 – 1.2) (1) <p><u>Example of calculation</u> $(10.0 - 0)/(0.040 - 0.004) = 280 \text{ cm min}^{-0.5}$</p>	4
Total for Question 5		18

**FOR INFORMATION ABOUT EDEXCEL, BTEC OR LCCI QUALIFICATIONS
VISIT QUALIFICATIONS.PEARSON.COM**

EDEXCEL IS A REGISTERED TRADEMARK OF PEARSON EDUCATION LIMITED

**PEARSON EDUCATION LIMITED. REGISTERED IN ENGLAND AND WALES NO. 872828
REGISTERED OFFICE: 80 STRAND, LONDON WC2R 0RL
VAT REG NO GB 278 537121**

GETTY IMAGES: ALEX BELMONLINSKY

ISBN 978-1-4469-4606-0



9 781446 946060 >