

# Chapter III

## Antiskid Brake Control Systems

### A. System Operation

The amount of braking the pilot uses has always been of concern. With a tailwheel-type airplane, too much braking could result in a noseover, and with the large diameter tires on the small wheels, there was always the possibility that too heavy braking could cause the tire to slip on the rim and pull the valve out of the tube.

The problem of brake control is still with us but, today, the reason is different. Our modern high-speed jet aircraft usually have more than one wheel on each side, and all of the brakes on one side are controlled with one pedal. With this arrangement, the pilot has no way to tell when one of these wheels begins to skid so he can take corrective action. And if corrective action is not taken within a few seconds to release a locked-up wheel, the tire will be blown and control of the aircraft can be lost.

To compound this problem, these high-speed aircraft have such restricted interior space that the wheels and tires must be very small and generally inflated to a high pressure. When this type of aircraft touches down on a wet surface runway and the pilot applies the brakes, the friction on the runway surface is so much less than that generated in the brake that the wheels lock up and the tire **hydroplanes** down the runway, supported on the water's surface in much the same way a waterskier is supported. All braking action and directional control is lost for that wheel.

For maximum brake effectiveness, the friction between the tire and the runway surfaces should

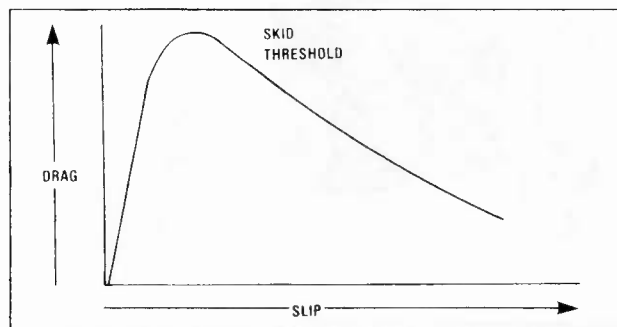

Figure 3-1. Maximum drag, which is optimum braking, requires just enough brake pressure to cause the tire to slip across the surface of the runway without skidding.

closely relate to the friction in the brake so that the peripheral speed of the tire will be just slightly less than the speed of the aircraft. In this way the tire will grip the runway surface and slip just a little. Doing this will create the maximum tire drag.

Maintaining this optimum friction is no easy matter, because if the brake pressure is held constant after the slip has started and the wheel has begun to decelerate, the brake friction will rapidly increase to the point that the wheel will lock up. The tire will skid over the runway and produce very little effective braking.

We use a very simple form of manual antiskid control in an automobile when we drive on ice. For the most effective stopping, we pump the brakes, applying them only enough to slow the wheel, but releasing them before the wheel decelerates enough to lock up. This same on-and-off type of operation has been employed in some of the early aircraft antiskid systems, but it has a major drawback if the control valves do not operate fast enough.

In Figure 3-2, we can see the way this problem comes about. When the brakes are applied, the pressure rises until the wheel starts to slip, but not skid, point A. This is the ideal condition, but the pilot has no indication that it has been reached, so he continues to increase the force on the brake pedal. A pressure is soon reached which produces enough friction in the brake to cause the tire to start to skid on the runway. The wheel now decelerates fast enough that the pilot can feel it, so he releases the pedal. But since the braking force required becomes less as the wheel slows down,

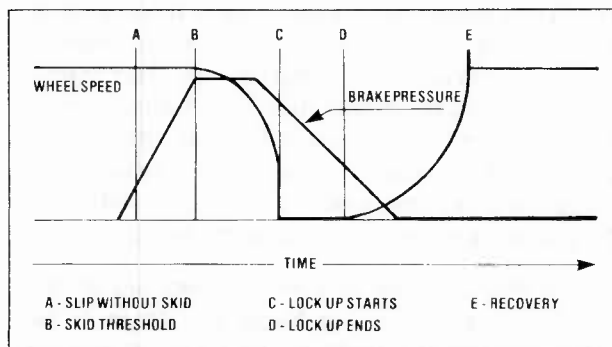

Figure 3-2. The development of a skid by on-and-off brake application.

the wheel continues to decelerate even though the brake pressure is decreasing. At point C, the wheel has completely locked up, and the pressure is still dropping. At point D, the pressure is low enough for the friction between the tire and the runway surface to start the wheel rotating again, and soon after the brake pressure drops to zero, the wheel has come back up to speed.

A successful antiskid system requires two features these early on-and-off systems did not have. There must be some form of wheel speed sensor that can detect a change in the rate of deceleration and signal for the pressure to be released before the wheel gets deep into its skid. And the valves must act fast enough so that not all of the pressure will be released before the next application.

This controlled amount of maintained pressure prevents the brake return system from pulling the pressure plate all of the way back and allows the brakes to be reapplied almost instantly.

The modern *modulated antiskid system* provides the fastest wheel-speed recovery and produces the minimum stopping distance on any kind of runway surface.

When the pilot wants to stop the aircraft in the minimum distance, he depresses the brake pedals to call for maximum braking. All of the brakes receive the maximum pressure, but if any wheel should start to decelerate at a rate which would indicate an impending skid, the pressure to that brake is dumped into the system return manifold. Now, the control circuit measures the amount of time required for the wheel to spin back up, and then applies a slightly reduced pressure to the brake, a pressure determined by the time required for the spin-up. If this reduced pressure causes a skid to begin to develop, enough of it is released to allow the wheel to spin back up. Some pressure is maintained in the wheel cylinders, however, just enough to prevent the pressure plate from moving all of the way back. This application and release process continues with progressively decreasing pressures until the wheel is held in the slip area, but not allowed to decelerate fast enough to produce a skid. It produces the proper amount of braking for any runway surface condition, with the pilot having only to call for maximum braking.

When the airplane is slowed down below approximately 20 miles per hour, and there is no further danger of skidding, the antiskid system automatically deactivates to give the pilot full control of the brakes for maneuvering and parking.

As with most of the auxiliary systems in modern aircraft, the antiskid systems have built-in test circuits and may, in the event of a malfunction, be deactivated so the pilot will have normal braking, but no antiskid protection.

## B. System Components

### 1. Wheel Speed Sensors

An antiskid system consists basically of three components: The wheel speed sensors, the control box, and the control valves.

There are two types of systems in use, an AC system and a DC system. They are essentially alike except for the wheel speed sensors, and one circuit in the control box.

The AC sensor is a variable *reluctance* AC generator, which uses a permanent magnet surrounded by a pickup coil in the axle of the landing gear. The outside of this sensor has four equally-spaced poles with teeth cut into their periphery.

A soft iron exciter ring with internal teeth is mounted in the hubcap of the wheel so that it rotates around the sensor. The two sets of teeth pass near each other and, as the exciter ring rotates, the teeth approach each other and then separate. As the distance between the teeth changes, the reluctance of the magnetic circuit is alternately increased and decreased, and each time it changes, the amount of magnetic flux cutting across the coil changes and induces an alternating current in the pickup coil. The faster the wheel turns, the higher the frequency of the induced current.

The control box used with the AC sensor converts the varying frequency into a DC signal whose voltage is proportional to the frequency of the AC.

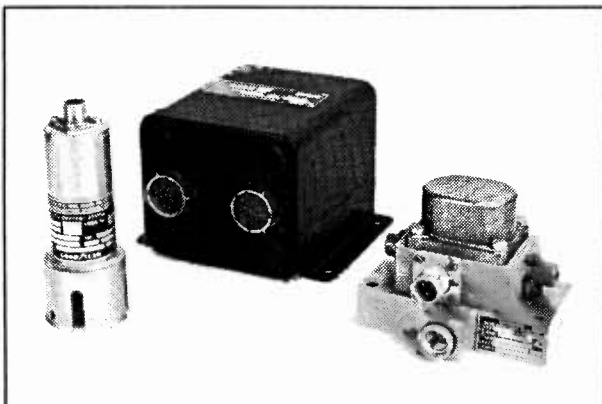

**Figure 3-3.** The three basic components of a modulated antiskid system are the wheel-speed sensor, the control box, and the control valve.

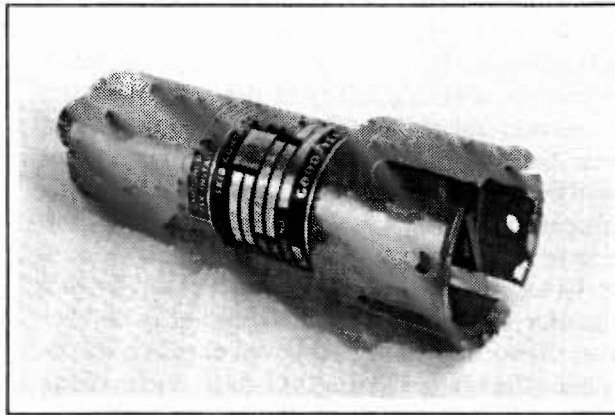

**Figure 3-4.** The direct current wheel-speed sensor is essentially a permanent-magnet DC generator whose output voltage varies directly as the rotational speed of the armature.

The DC sensor is essentially a small permanent-magnet direct-current generator whose voltage output is directly proportional to the rotational speed of its armature. When this type of sensor is used, there is no need for the **converter** in the control box, and there is less danger of stray voltages induced into the system causing brake interference.

The shaft of the armature is fitted with a blade driven by a bracket in the wheel hubcap, and rotates with the wheel. The generator output is usually in the range of one volt for each ten miles per hour of wheel speed.

### QUESTIONS:

1. What is meant by hydroplaning?

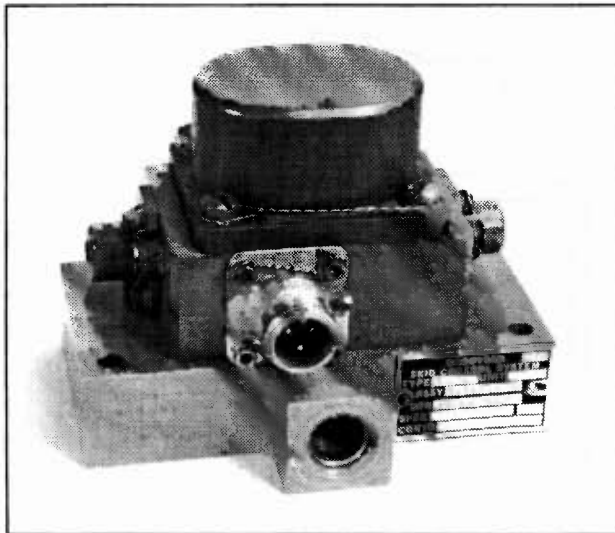

**Figure 3-5.** The antiskid control valve, located between the brake valve and brake, allows fluid to flow into and out of the brake for normal operation, but dumps the fluid directly into the return manifold if a skid develops.

2. Why does a modulated antiskid brake system hold some pressure in the brake, rather than releasing it all?

3. What feature in an antiskid brake system allows the pilot to have full braking action for low-speed taxiing and parking?

4. What is sensed in an AC wheel speed sensor to determine the rate of deceleration of a wheel?

5. What is sensed in a DC wheel speed sensor to determine the rate of deceleration of a wheel?

## 2. Control Valves

A three-port antiskid control valve is located in the pressure line between the brake valve and the brake cylinder, with a third line connecting the control valve to the system return manifold.

For normal operation of the brakes, when no skid is being indicated, the valve allows the brake fluid to flow into and out of the brake, with the valve serving only as a passage. But, if the wheel speed sensor determines that one of the wheels is beginning to decelerate fast enough to cause a skid, its changing

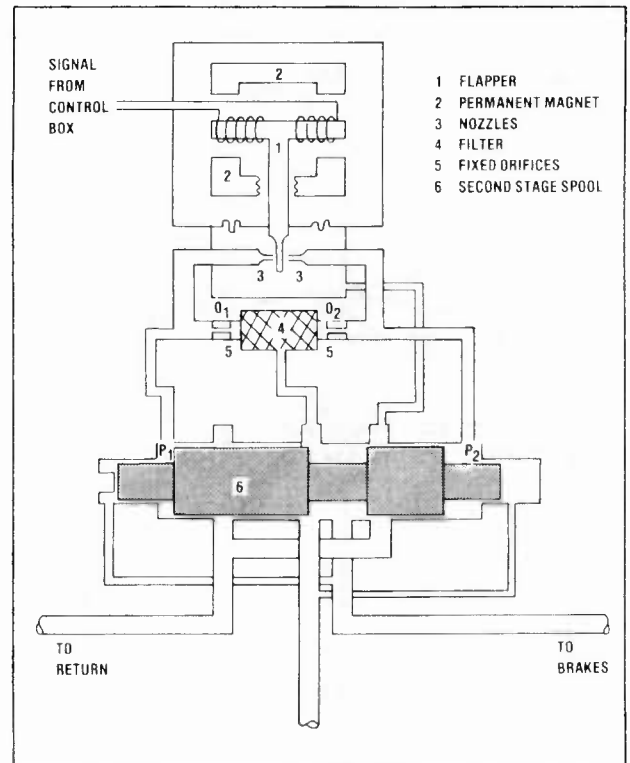

**Figure 3-6.** A direct current signal from the control box energizes the coil on the armature of the flapper valve, and movement of the flapper changes the pressure drops across the fixed orifices. This varies the pressure on the lands of the second stage spool valve to control the flow of fluid through the valve.

output voltage is measured in the control box, and a direct current signal is sent to the control valve to close off the pressure port and open the passage between the brake and the system return.

This valve operates fast enough to maintain an output pressure that is directly proportional to the amount of signal current from the control box.

The direct current signal from the control box flows through a coil around the armature of the flapper valve. This armature is free to pivot and is centered between two permanent magnets.

When the signal from the control box indicates that no skid is impending, and the braking action should be normal, the magnetic field of the coil will react with the fields of the permanent magnets and hold the flapper centered between the nozzles.

Fluid from the brake valve flows through the filter and discharges equally from each nozzle. Since the amount of flow is the same through each orifice, the pressure drop across the orifices will be the same, and the second stage spool valve will assume a position that allows free passage between the brake valve and the brake.

When the control box receives a signal from the wheel speed sensor that a skid is impending, it sends current through the coil of the armature that creates such a polarity in the armature that it pivots and unbalances the flow from the nozzles. In our illustration of Figure 3-7B, the flapper has moved over, restricting the flow from the left nozzle and opening the flow from the one on the right. There is now more flow through orifice  $O_2$  and therefore a greater pressure drop across it, leaving  $P_1$  greater than  $P_2$ . This imbalance of pressures moves the second stage spool over, shutting off the flow from the brake valve to the brake, and opening a passage from the brake to the return manifold.

This extremely fast reaction time for this type of valve allows it to maintain a pressure at the brake that is directly proportional to the amount of current flowing in the armature coil.

### QUESTIONS:

6. What is the function of the antiskid brake valve for normal brake operation?
7. What is the function of the flapper valve in the brake control valve?

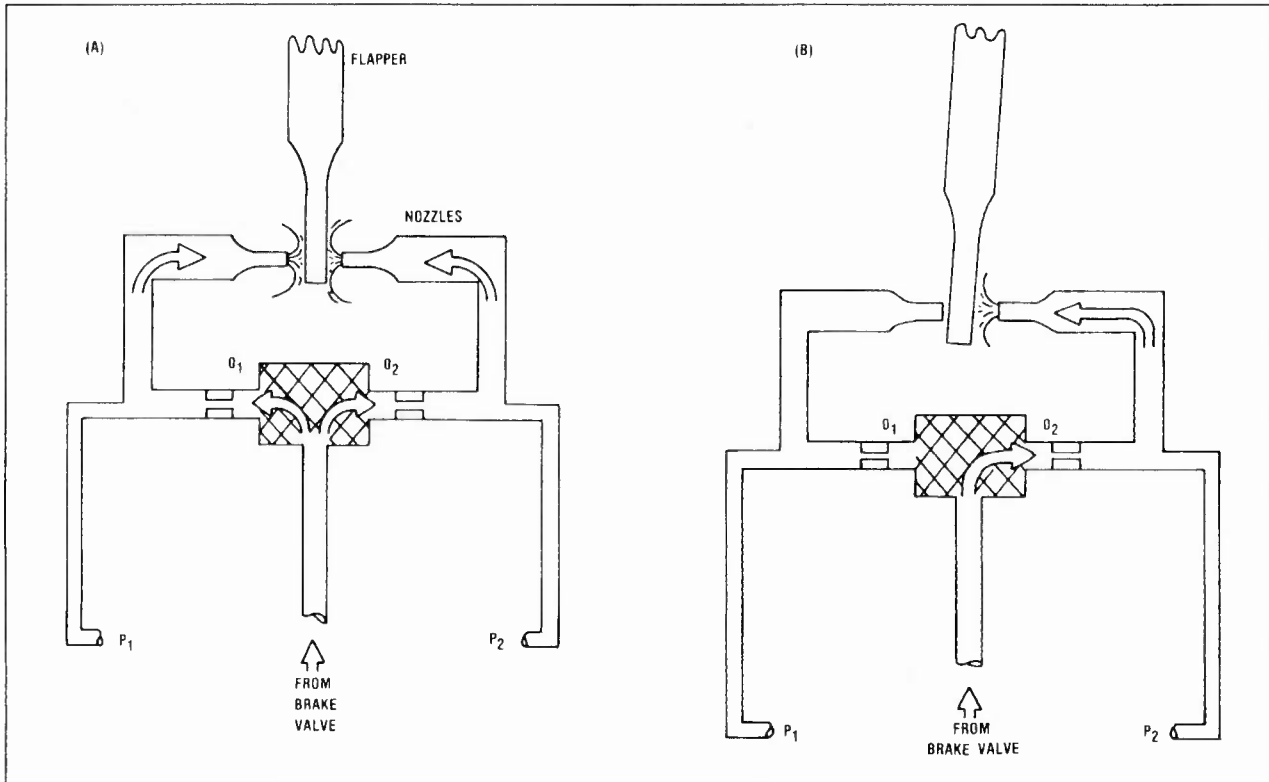

**Figure 3-7A.** When the flapper is centered between the nozzles, the pressure drops across  $O_1$  and  $O_2$  are the same, and  $P_1$  equals  $P_2$ .

**Figure 3-7B.** When the armature of the flapper valve is energized, the flapper moves over, restricting the flow through  $O_1$  while increasing through  $O_2$ . The increased pressure drop across  $O_2$  causes  $P_1$  to be greater than  $P_2$ .