

Minnesota Department of Health
Minnesota Rural Water Association

Class D Study Guide

This study guide is designed for operators taking the Class D water operator certification exam and is a condensed version of the *Minnesota Water Works Operations Manual*. This tool, along with your operating experience and common sense, should help you pass the certification exam.



The exam consists of approximately one hundred questions. An operator must correctly answer at least 70% of the questions to obtain state certification. Once certified, a class D operator must also acquire at least 8 hours of continuing education credits every three years to maintain certification. These credits are acquired by attending state approved training classes on subjects relating to the drinking water industry.

Disclaimer

Several photographs and illustrative drawings that appear in this study guide have been furnished through the courtesy of various product distributors and manufacturers. Any mention of trade name, commercial products, or services does not constitute endorsement or recommendation for use by the Minnesota Department of Health or the Minnesota Rural Water Association.

This study guide presents a summary of regulations applicable to small drinking water systems. Should the summarized information in this document be inconsistent with a governing rule or statute, the language of the rule or statute shall prevail.

The production of this study guide was a cooperative effort of staff from the Minnesota Department of Health, Minnesota Rural Water Association, and St. Cloud Technical College. We would like to express our heartfelt appreciation to everyone who assisted in this process for his or her time and efforts. These individuals include: Cindy Cook, Karla Peterson, Dave Hokanson, Robyn Bruggeman, Stew Thornley, Don Christianson, Jennifer Koenig, Jeff Dale, Ruth Hubbard, Lori Blair, Bill Spain, Keith Redmond, and Mike Clemens.

First Edition Copyright© 2004 Minnesota Department of Health

Second Edition Copyright© 2009 Minnesota Department of Health

This study guide may be reproduced, in whole or in part, for educational purposes only. Please credit the “Minnesota Department of Health/Minnesota Rural Water Association” if any portion of this study guide, including photographs, is used in another publication.



Minnesota Department of Health
Section of Drinking Water Protection
625 North Robert Street
P.O. 64975
St. Paul, MN 55164-0975
Phone: 651-201-4700
Web: www.health.state.mn.us/divs/eh/water



Minnesota Rural Water Association
217 12th Avenue SE
Elbow Lake, MN 56531
Phone: 800-367-6792
Fax: 218-685-5272
E-mail: mrwa@mrwa.com
Web: www.mrwa.com

Table of Contents

Safe Drinking Water Act.....	2
Sources of Drinking Water.....	3
Well Construction	4
Drinking Water Standards	9
Regulated Drinking Water Contaminants	10
Microbiology.....	11
Coliform Bacteria Sampling.....	12
Other Sampling Requirements.....	13
Record Keeping.....	13
Consumer Confidence Reports.....	13
Recommended Standards for Operating and Maintaining Your Water System	14
Chemistry.....	15
Taste and Odor Control.....	16
Iron and Manganese.....	17
Chemical Addition	19
Phosphate Addition	20
Disinfection.....	23
Fluoridation.....	28
Corrosion.....	30

Pipe Cleaning.....	34
Distribution.....	35
Valves.....	37
Meters	40
Hydrants	43
Cross Connections and Backflow Prevention	45
Pumps	48
Storage	54
Electrical Safety	55
Leak Detection	56
Meter Reading.....	57
Safety.....	57
Traffic Control.....	60
Security	61
Math	62
Operator Certification Requirements.....	71

Preface

The need for and benefits of drinking water have been known for a long time. Ancient Egyptians placed their water in big jars to allow large particles, such as soil, to settle to the bottom. Others strained their water through cloth to remove particles. These are actually crude forms of types of treatment that are done today. A big difference between then and now is that the primary purpose of treatment done thousands and even just hundreds of years ago was to improve the taste and appearance of water – not to remove contaminants that could cause them to get sick.



It wasn't until more recently, in the last 150 years or so, that it became apparent that treatment of drinking water was needed, not just to improve its aesthetic qualities, but also to protect public health. Finally people were realizing that the quality of drinking water couldn't be accurately judged by the senses – by looking at it, smelling it, or tasting it. Water that looks and tastes fine may not be safe to drink. And vice versa.

In December 1974, the Federal Safe Drinking Water Act (SDWA) was passed. The SDWA is a national program of regulations and standards that covers all public water systems in the United States. The United States Environmental Protection Agency, or EPA, oversees the SDWA, although most states, including Minnesota, have taken over the responsibility of administering and enforcing the provisions of the Act in their states. In essence, the Minnesota Department of Health (MDH) is a subcontractor of the EPA. They pay MDH to administer the SDWA in Minnesota. They also audit MDH to make sure things are being handled correctly. If not, they can rescind their contract with MDH.

The jurisdiction of the drinking water program at MDH applies only to public water systems, those that service water to the public. This includes municipal water systems as well as facilities, such as mobile home parks or factories, that have their own source of water and that serve it to the public. Whether the system is privately owned or not, if it serves water to more than 25 people, it is considered a public water supply and subject to the regulations of the Safe Drinking Water Act.

Safe Drinking Water Act



The Federal Safe Drinking Water Act (SDWA) is the principal regulation governing public water systems in Minnesota. It defines what a public water system is, sets drinking water quality standards, institutes water sampling and survey schedules, establishes requirements for source water protection and operator certification, and more.

Water System Types

Minnesota's safe drinking water regulations established under the Federal Safe Drinking Water Act define a PWS as "a system providing piped water for human consumption and either containing a minimum of 15 service connections, or serving at least 25 persons daily for (at least) 60 days a year." The regulations also differentiate between Community Public Water Supply (C-PWS) systems and Noncommunity Public Water Supply (NC-PWS) systems.

Community

A community public water system "serves at least 25 year-round residents, or serves 15 service connections used by year-round residents."



Municipal Community

These systems are owned by a municipality. "*The City of*"

Nonmunicipal Community

A private party owns these systems. *Nursing homes, prisons, mobile home parks, housing developments, and apartments*



Noncommunity



Transient Noncommunity

A PWS that serves at least 25 people at least 60 days of the year but does not serve the same 25 people over 6 months of the year. *Restaurants, campgrounds, hotels, and churches*

Nontransient Noncommunity

A NTNC-PWS system is "a public water supply that is not a community water supply and that regularly serves at least 25 of the same persons over six months per year." *Factories, office buildings, day-care centers, and schools*



Sources Of Drinking Water

Sources of raw water, whether surface water or groundwater, should be adequate to meet the demands of the water supply. Appropriation of more than 10,000 gallons of water per day or 1,000,000 gallons per year requires a permit from the Department of Natural Resources.

Surface Water

- Water taken from lakes, reservoirs, or rivers is considered surface water.
- Surface water supplies about 75 percent of the water consumed by people in the United States. Even though a larger number of water systems in the United States use a groundwater source, on the average, they are smaller and serve fewer people. Surface water is a more likely source for large cities.



Groundwater

- Groundwater results from water percolating through the ground and saturating soil or rock beneath the surface. The zones of saturation where water is stored are called **aquifers**. Wells are constructed to reach down into aquifers and remove this stored water.
- An **aquifer** is an underground layer of gravel, sand, sandstone, shattered rock, limestone, or other formation that holds water. An aquifer will not only hold water, but will allow the water to move to an area of lower pressure within the aquifer. You could think of the movement of groundwater as a slow moving underground river or stream.

Hydrologic Cycle

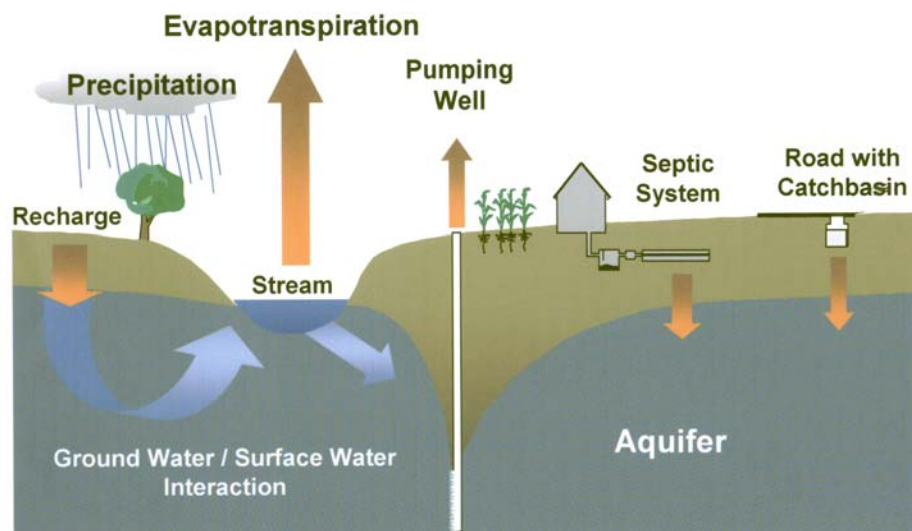

Well Construction

Drilling Methods

In Minnesota, two basic methods for drilling a well are used: the cable tool method and the mud rotary method. (Other methods – such as air rotary drilling, air percussion drilling, jetting, and augering – are used occasionally for small wells, but the cable tool and mud rotary methods are the most common.) Driven wells are used for smaller diameter wells where the aquifer used is near the ground surface.

All wells must be constructed in compliance with the Minnesota Water Well Construction Code (Minnesota Rules, Chapter 4725).

Isolation Distances

The well code specifies minimum isolation distances from potential sources of contamination. Some of the most commonly applicable isolation distances include the following:

Chemical storage (greater than 25 gallons or 100 pounds), without safeguards	150 feet
Manure storage	100 feet
Cesspools, leaching pits, drywells	75 feet
Drainfield (small system), buried sewer, septic tank, animal, or poultry yard.....	50 feet

Additionally, please note the following:

- **Community water supply wells must be at least 50 feet from any potential contaminant source listed in the well code (unless a greater isolation distance is specified).**
- Certain isolation distances are doubled for wells less than 50 feet deep when no confining layer is present.
- A community public water system must own or legally control, through a permanent easement, the property within a 50-foot radius of the well.

See the Minnesota Water Well Construction Code for a complete list of isolation distances and their applicability.

Groundwater Wells

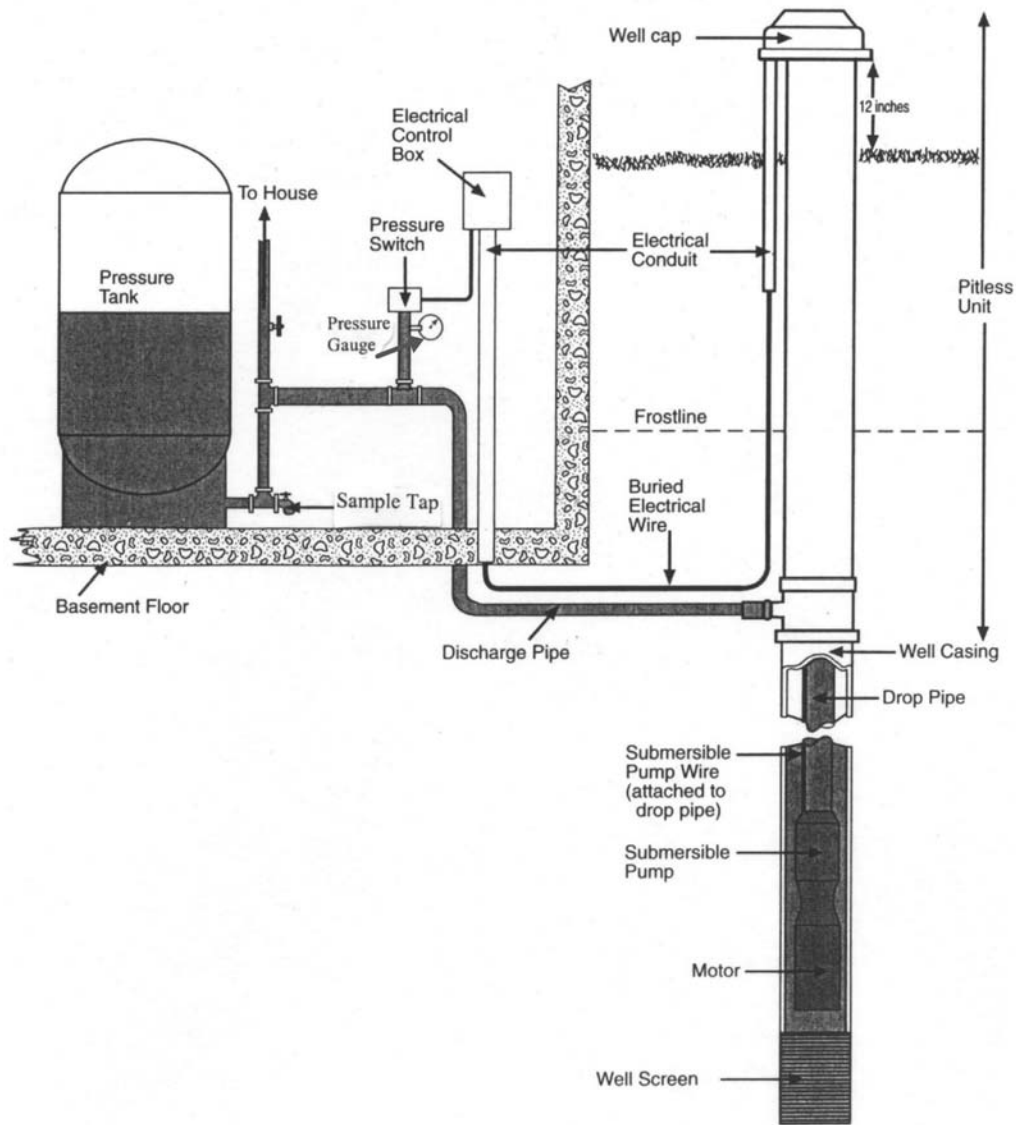

Well Casing

The casing provides a connection to the groundwater and a pathway for bringing the water to the surface. The casing may prevent loose soil, sediment, rock, and contaminants from entering the well. Casings also prevent aquifer contamination by preventing interaquifer flow.



Well Cap

Watertight, weatherproof, and insect-proof water supply well covers are required to prevent contamination of the well. Electrical connections for the pump and any treatment installations also require weatherproof and insect-proof covers.

Well Ventilation

An air vent is needed for most wells to allow air to enter the well when the pump turns on to prevent the well from collapsing due to the vacuum that is created. The vent also helps to relieve pressure after the pump is shut off. This vent is usually part of the well cap. Having the vent screened and down-turned helps prevent contamination of the well. Without the screen in place, insects, dust, debris, etc. can easily contaminate the well.

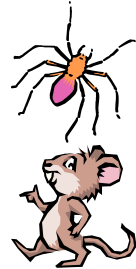

Sanitary Well Seal

A sanitary well seal is used instead of a well cap on wells that have piping exiting at the top of the casing, for example, a well with a jet pump. A one-piece top plate sanitary seal must be used for wells in outdoor locations. A two-piece top plate sanitary seal may be used for wells located inside of a well/pump house.

Check Valve

The check valve is used to prevent water from flowing back down into the well when the pump has been shut off. If the check valve fails, the water flowing back down into the well will stir up the geological formation, which may cause silt, sand, or other materials to be present in the drinking water. Check valves also prevent contaminants from backflowing into the water supply.

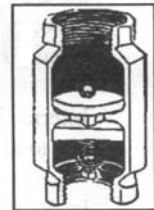

Drop Pipe

A drop pipe is a vertical pipe that carries water from a submersible pump, located in the well casing, to an underground discharge coupling (pitless adapter or pitless unit), or out the top of the casing.

Well Screen

In cases where the well is drilled into an unconsolidated formation, such as sand or gravel, a screen is provided at the bottom of the casing. Screens are designed with different shapes and opening sizes to keep the formation material out while allowing water through.

Water Sample Tap

A sample tap is required for collection of water samples prior to and after any treatment. To prevent possible contamination of the water supply, the tap must have a smooth nozzle. A threaded tap must have the threads ground off to prevent connecting a hose to the tap. A sample tap should be installed at or near every (groundwater) well. This will enable proper source water sample collection.

Pressure Gauges

Pressure gauges are used throughout the system to show the amount of pressure being developed by the pump. It is sometimes very helpful in locating pump trouble. Pressure gauges should be located before and after each pump. A pressure gauge on the distribution system allows you to measure the pressure in the distribution lines.

Grouting

Openings or voids may be created around the casing during the drilling process. These voids, or annular spaces, are filled by the driller with a type of cement called “grout”. An open annular space between a drill hole and a casing, or between an inner and an outer casing, presents a direct pathway for contaminants to enter a well and the groundwater. Grouting is required for wells that are constructed by methods which: drill a borehole larger than the casing (rotary, jetting, auger); drill through contaminated aquifers; drill into more than one aquifer; and have multiple casings.

- Grouting refers to the filling or sealing of a space with a low permeability material or grout such as Portland cement or sodium bentonite.
- Grouting provides support for the casing (particularly important for plastic casing).
- Grouting prevents interaquifer flow.
- Grouting prevents surface or near-surface contamination from entering a well.
- Grouting seals a casing to prevent “washouts” due to flowing wells.
- Grouting protects steel casing from corrosion.

Well Pumps

Two types of pumps are generally used, vertical turbine and submersible.

Vertical turbine - deep well turbine pumps are lubricated with water for potable water sources. The water-lubricated or open-shaft type pump has rubber line-shaft bearings mounted in spiders supported by the outer column pipe. All bearing surfaces must be made of rust resistant material such as stainless steel to prevent excessive friction and wear.

Submersible - submersible pumps have a motor and pump combined in a close-coupled unit with the complete assembly suspended below the water surface by the discharge pipe. Submersible pumps can be installed in crooked wells and in wells of almost any depth. They can accommodate heads up to 1,500 feet and capacities up to 30,000 gpm.

Discharge Piping

Discharge piping from the well must be equipped with a check valve, shut-off valve, pressure gauge, flow measuring device, raw water sampling tap (no hose threads), and an air release vacuum relief valve or surge tank. The air release vacuum relief valve must be located upstream of the check valve. Chemical treatment injection points must be located downstream of the check valve so that chemicals cannot flow back into the well.

The air release vacuum relief outlet pipe must be at least 18 inches above the floor, down-turned, and screened. A casing vent must be provided. The vent must be down-turned at least 24 inches above the floor/ground and screened.

Measuring Levels in Wells

One of the most important pieces of information the water-system operator needs is the water levels in the well before startup (static level) and the pumping level after the pump has run until the well has reached a stable condition (pumping level). The well has reached a stable condition after the water level in the well has stopped dropping. In most cases, this takes at least one hour and can often take much longer. The feet of drawdown is the distance between the static groundwater level and the pumping level.

Example of a Deep Well Turbine

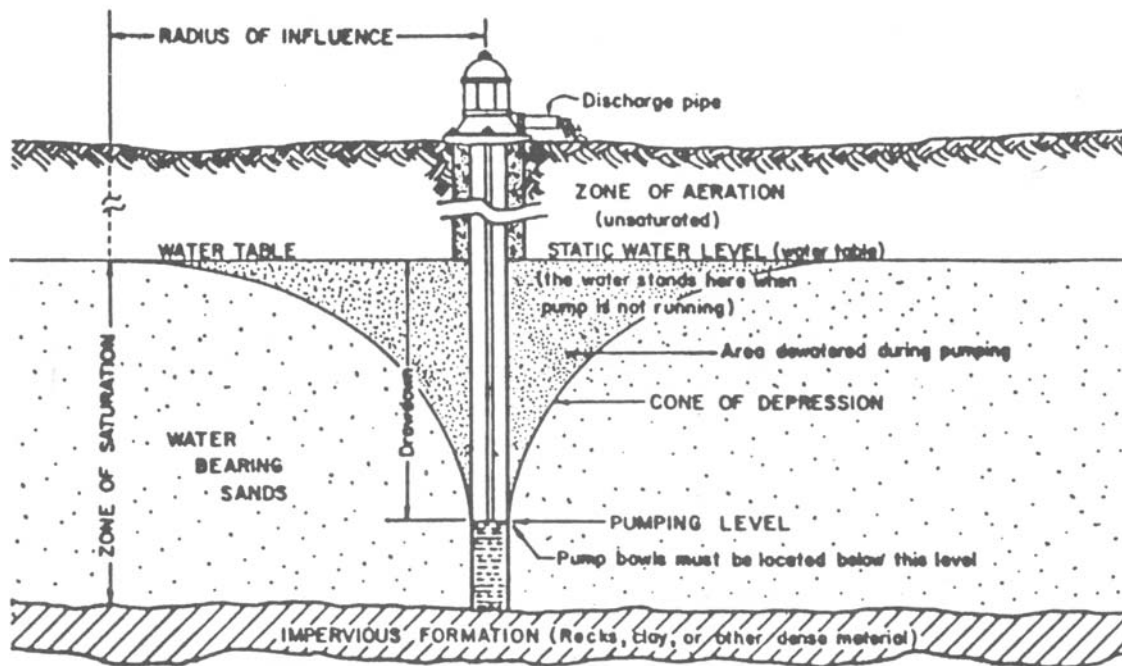

The water level in the well will drop rapidly right after the pump starts and then slow considerably, dropping to an inch per hour or less, until the level stabilizes. What has happened is that the pump has lowered the head pressure exerted by the aquifer in the vicinity of the well. The resulting cone-shaped pressure reduction around the well is called the cone of depression. It extends in an area around the well out to a point at which the pressure equalizes and returns to normal. The distance from the well to this normal pressure area is called the radius of influence. If wells are located too close together, the cones will intersect or overlap, influence the water level in each well, and cause a lower pumping level and a drop in yields.

Drinking Water Standards

The Safe Drinking Water Act (SDWA), passed in 1974 and amended in 1986 and 1996, gives the Environmental Protection Agency (EPA) the authority to set drinking water standards. Drinking water standards are regulations the EPA sets to control the level of contaminants in the nation's drinking water. There are two categories of water standards:

- A **National Primary Drinking Water Regulation** (primary standard) is a legally-enforceable standard that applies to public water systems. Primary standards protect drinking water quality by limiting the levels of specific contaminants that can adversely affect public health and are known or anticipated to occur in water. They take the form of Maximum Contaminants Levels (MCL's) or Treatment Techniques.
- A **National Secondary Drinking Water Regulation** (secondary standard) is a non-enforceable guideline regarding contaminants that may cause cosmetic effects (such as skin or tooth discoloration) or aesthetic effects (such as taste, odor, or color) in drinking water. EPA recommends secondary standards to water systems but does not require systems to comply.

The primary responsibilities of the MDH regarding the SDWA are as follows:

1. Enforcement of the SDWA regulations;
2. Conducting sanitary surveys for Public Water Supplies (PWSs);
3. Training and technical assistance for water operators;
4. Certification of testing laboratories; and
5. Plan review of new or modified PWS facilities.

Drinking water regulations change often, as more is known about the contaminants in water, as increasing development causes more impacts and demands on our water sources, and as better treatment technologies are developed.

Drinking water, including bottled water, may reasonably be expected to contain at least small amounts of some contaminants. The presence of contaminants does not necessarily indicate that water poses a health risk. Your water system is continually monitored for the presence of hundreds of substances such as radioactive, biological, inorganic, volatile, or synthetic organic contaminants. The table listed on the next page shows only a few more common contaminants detected in the water.

Regulated Drinking Water Contaminants

CONTAMINANT	MCL/ ACTION LEVEL (AL)*	SOURCE	HEALTH RISKS CHRONIC/ ACUTE**	MONITORING FREQUENCY ***	SAMPLE COLLECTOR
<i>BACTERIA</i> (MICROBIOLOGICAL)	0 (NO COLIFORM BACTERIA SHOULD BE PRESENT)	NATURALLY OCCURRING IN THE ENVIRON- MENT/ HUMAN AND ANIMAL WASTES	ACUTE	ANNUAL	WATER SYSTEM/ MDH
<i>NITRATE</i> (INORGANIC)	10 mg/L	ANIMAL WASTES AND FERTILIZERS	ACUTE – INFANTS UNDER 6 MONTHS OF AGE WHO DRINK WATER HIGH IN NITRATES MAY BECOME SERIOUSLY ILL (BLUE BABY SYNDROME) AND MAY DIE	ANNUAL	WATER SYSTEM/ MDH
<i>ARSENIC</i> (INORGANIC)	0.01 mg/L	NATURALLY OCCURRING MINERAL IN SOIL AND BEDROCK, BEDROCK AND UNDER- GROUND SOIL	CHRONIC	1 SAMPLE EVERY 3 YEARS AND REDUCED BASED ON HISTORICAL MONITORING	MDH
<i>LEAD/COPPER</i>	LEAD 0.015 mg/L COPPER 1.3 mg/L	LEAD PIPES, SOLDER IN HOUSEHOLD PLUMBING, AND BRASS FIXTURES	CHRONIC	BEGINS EVERY 6 MONTHS AND REDUCED BASED ON HISTORICAL MONITORING	WATER SYSTEM

* Maximum Contaminant Level (MCL) is the greatest amount of a particular contaminant allowed in drinking water by EPA. Action Level (AL) is a contaminant concentration that, if reached, requires specified actions by the public water supply.

** Most contaminants are considered chronic, meaning that cancer or other ill health may result if the contaminant is consumed at relatively low concentrations over extended periods of time. Acute contaminants may have the potential to pose an immediate health risk if consumed.

*** Additional monitoring may be required if contaminants are detected at elevated levels or certain population requirements are met.

Microbiology

- The presence of waterborne pathogens (disease-producing organisms) is often related to poor sanitation practices. Diseases caused by pathogenic bacteria, viruses, and protozoa can be transmitted through fecal contamination to humans; drinking water is just one of several carriers of the infectious agents.
- Microorganisms associated with waterborne outbreaks include protozoa, bacteria, and viruses. Gastroenteritis, typhoid, dysentery, cholera, infectious hepatitis, amoebic dysentery, and giardiasis are some common types of waterborne diseases.
- It is difficult and sometimes hazardous to test for the presence of pathogens, and the technician would have to test for many pathogens to be certain none are present. Instead, the technician or operator tests for the presence of organisms that indicate that pathogens may also be present. The indicator test identifies the coliform group of organisms. Extensive research has shown that if the coliform group of bacteria is present, there is a probability that one or more pathogens may also be present.
- Coliform bacteria by themselves are not pathogenic and do not necessarily indicate a health hazard. However, the presence of the total coliform group of bacteria indicates general contamination. Therefore, coliform have been chosen to be the bacterial group routinely tested for to assess the bacteriological safety of water. The total coliform presence/absence test is the most useful indicator of possible contamination in drinking water.
- The coliform group of organisms is found both in soil, and in the waste of warm-blooded animals. It includes fecal coliform bacteria, which indicates contamination of human or animal origin, and Escherichia Coli (E. coli), which is a common bacterium in the feces of warm-blooded animals.



Common Types of Sample Bottles

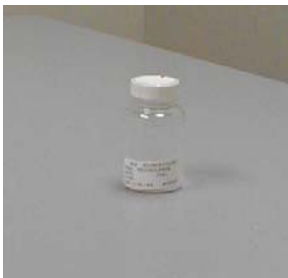

Bacteria



Nitrate



Lead and Copper

Coliform Bacteria Sampling



- Samples must be analyzed by the laboratory within **30 hours** after being collected. Any samples received after this period of time will be rejected, and another sample will have to be taken.
- Repeat samples are required if a routine water sample is found to contain coliform bacteria. The current regulations require that if a sample is positive (shows the presence of coliform), the water supplier must take four more samples: one at the same location as the sample that was positive, one within five service connections on each side of the positive location, and one from a representative site on the distribution system.
 - The number of samples to be collected is based on the population served.
 - Increased monitoring may be necessary if a system has a history of coliform contamination.
- Samples shall be collected at points that are representative of the distribution system.
- Proper sampling procedure:
 1. Select representative points of the distribution system to sample.
 2. Remove any faucet attachments such as an aerator.
 3. Disinfect faucet with alcohol or flame from a small torch.
 4. Run water in a steady stream for 5 minutes.
 5. Open sampling container. Handle the cap carefully to prevent contamination of the sample.
 6. Only containers that are sterile and contain sodium thiosulfate to neutralize the chlorine in the water sample should be used.
 7. Grasp the container near the bottom.
 8. Place the container under the flowing stream.
 9. Fill the bottle to the neck or indicated fill line. Don't overflow or rinse out the bottle.
 10. Replace the container cap.
 11. Label the container.
 12. Complete the required forms.
 13. Place the container and form in the shipping box.
 14. Immediately send the box to the laboratory indicated on the mailing label.
- Results of samples found to contain coliform organisms, and the results of all repeat samples, must be reported to the Department of Health within **24 hours** of analysis.



Groundwater Rule

Beginning January 1, 2010, water suppliers that use groundwater sources must collect one sample from each source (well) that may have produced the positive sample water. All source water samples must be analyzed for E. coli presence. Suppliers to populations <1,000 may use their source water sample(s) as their “representative site” samples.

Other Sampling Requirements

Nitrate

The most common sources of nitrates in drinking water are fertilizers, septic tanks, sewage, and decomposition of organic materials. Nitrates prevent hemoglobin from transporting oxygen in the blood stream.

- Excessive levels of nitrates can cause “blue baby syndrome”, or methemoglobinemia.
- Do not boil water with high nitrate levels. This will only increase the concentration, not remove it.

Sampling procedures for nitrates are similar to bacteriological samples except that flaming the faucet is not necessary, and the sample is collected at an entry point to the water system rather than the distribution system. An **entry point** is a location in the water system after treatment or chemical addition (if any) but before the distribution system.

Lead and Copper

Although lead and copper are both inorganic compounds that occur naturally in the environment, their presence in drinking water may pose a health risk. Lead and copper commonly enter tap water through corrosion of plumbing materials.

- Increased lead levels in water can cause impaired mental function in children and increased blood pressure or kidney problems in adults.
- Copper at high doses can cause stomach and intestinal distress, liver and kidney damage, and anemia.

Public water systems are required to sample for lead and copper every 6 months for initial base monitoring. Whenever possible, collect your lead and copper samples from the same locations each time you sample. Samples must be **first-draw** at the consumer’s tap after water has been motionless in the plumbing for a **minimum of 6 hours**.

Record Keeping

The owner or operator of a public water system must retain copies of their records (sample results forms, sanitary surveys, etc.) for a number of years. The length of time varies by record. These records must contain certain information and must remain on the premises or at a convenient location near the premises.

Consumer Confidence Reports

The Consumer Confidence Report (CCR) is a report that community water systems (municipal and nonmunicipal) must provide or make available to their customers annually before July 1st. The CCR tells consumers what contaminants have been detected in the drinking water, how the results compare to standards, and where the water comes from. The report shows customers the efforts made by the water supplier to provide safe water. It is designed to inform customers of the quality of the water they are drinking. As of Jan. 1, 2010 it will also tell consumers about any significant deficiencies that have not been corrected.



Recommended Standards For Operating And Maintaining Your Water System

- Know the location of your well(s) and inspect the well(s) on a routine basis.
- Provide a secure and intact well cap. Older well caps often do a poor job of keeping insects and dirt out of the well. If possible, replace older caps with an overlapping well cap that includes a compression gasket and screened vent.
- Be sure the well casing extends at least **one foot** above the ground surface to reduce the possibility of surface water or other contaminants entering the well. Avoid landscaping projects that reduce the distance between the ground and the top of the well casing to less than the required minimum distance.
- The casing shall be vented to the atmosphere. For **community** water supplies, the vent shall end at least 18 inches above the finished floor elevation.
- The floor grade of the well/pump house shall be one foot above the highest known flood level and 6 inches above grade.
- Direct surface and roof runoff away from the well. Surface water should not collect within 50 feet of the well.
- Community public water supply wells must have a minimum distance of **50 feet** from any contamination source.
- Discharge piping shall be equipped with a check valve, shut-off valve, pressure gauge, meter, sampling tap, and an air release vacuum relief valve located upstream from the check valve.
- A well house floor drain, when not connected to a sanitary sewer, shall be connected to a gravel pocket. The gravel pocket shall be at least 30 feet from the well.
- Protect wells from potential vehicle damage. Direct vehicular traffic away from the well or surround the well casing with rigid posts or large rocks to help protect the well from damage.
- To the extent possible, remove any potential sources of contamination from the area near the well. All new wells must meet the minimum requirements for separation from potential contaminant sources.
- At least two pumping (booster) units shall be provided.
- Water used for priming or lubricating the pumps must not be of lesser sanitary quality than that of the pumped water.



Chemistry

It is important to understand how water acquires its various characteristics. The material the aquifer is located in determines the characteristics of the water supply and the methods for treatment. Water quality characteristics fall into two categories, **physical** and **chemical**.

Physical

- **Temperature** – measured on either of two scales, the Fahrenheit (F) scale or the Celsius (C) scale. The freezing point of water is 32°F or 0°C; the boiling point of water is 212°F or 100°C. Temperature affects how efficiently unit processes will work in the water system. Warmer water may increase chlorine demand and algae growth. 
- **Turbidity** – the cloudy appearance of water due to particles suspended in the water. Turbidity is measured by passing a beam of light through a cloudy water sample. The light reflects off the particles, measuring the clarity of the water, expressed in Turbidity Units (TU).
- **Color** – usually indicates the presence of decomposed organic material such as leaves, plants, wastewater, or certain inorganics such as iron and manganese. Color is measured by comparing a sample with the color of a standard chemical solution. The units of measure are Color Units (CU).
- **Taste and Odor** – can be caused by algae, microorganisms, decaying organic matter, wastewater, minerals, and dissolved gases such as hydrogen sulfide. The amount of odor in the water is measured by an odor detection test that indicates the Threshold Odor Number (TON).

Chemical

- **pH** is a measure of the hydrogen ion concentration in water. The term is used to express the acid or alkaline condition of the water. pH is measured on a scale ranging from 0 to 14 with 7 considered neutral. At a pH below 7, the water is acidic (corrosive); at a pH above 7, the water is alkaline (scaling). The normal range of pH for groundwater is 6.0 to 8.5; the pH of surface water is 6.5 to 8.5. 
- **Hardness** in water is caused by significant amounts of dissolved calcium or magnesium that comes from water flowing through soil and rock formations such as limestone or dolomite deposits. A range of 300 to 400 ppm is a typical range for hardness in groundwater.
- **Dissolved Oxygen (DO)** is a measure of water quality indicating free oxygen dissolved in water. It can increase algae growth and accelerate pipe corrosion. Colder water contains more DO than warmer water.
- **Dissolved Solids** – water can contain toxic dissolved minerals such as arsenic, lead, and mercury, or nontoxic minerals such as iron and calcium. Excessive dissolved solids can produce taste, odors, hardness, corrosion, and scaling in the distribution system. The recommended maximum limit of total dissolved solids (TDS) in drinking water is 500 ppm.

Taste And Odor Control

The typical water-system customer judges the quality of the water by its color, sparkle, and taste. If the customer is satisfied with these qualities, he or she assumes the water is safe to drink. However, if the taste of the water changes, the customer often will call the supplier and complain that the water is contaminated. In reality, it is unlikely that any harmful contaminants in the water could even be noticed because of their taste or smell.

- Taste and odor, though primarily aesthetic concerns, can be indicators of pollution from sources such as domestic or industrial waste.
- Two of the most common sources of taste and odor in groundwater are iron and sulfur deposits, and dissolved methane gas.
- Taste and odors occurring in the distribution system are primarily the result of corrosion of pipe. Eliminating dead end mains and providing adequate flushing of the system can reduce taste and odors. Pipe corrosion can be reduced by adjusting the pH of the water and by adding corrosion inhibitors such as phosphates to the finished water.

Control Measures



Wellhead Protection

Wellhead protection, or groundwater source management, involves the prevention of contaminants from entering the source. Groundwater may become contaminated by pollutants such as gasoline, industrial solvents, and a wide variety of volatile organics.

Removal by Treatment

In small systems, in-line carbon filters can reduce tastes and odors associated with hydrogen sulfide, methane gas, pipe corrosion, and growth of iron bacteria. In larger systems, oxidation, aeration, and activated carbon are used with filtration to reduce tastes and odors.

- **Oxidation** can be carried out with chlorine, air, or *potassium permanganate*, the chemical most often used. The chemical is a very strong oxidant. According to the California Department of Health Service's *Water Treatment Plant Operation*, a dosage range of 0.1 to 0.5 mg/L has been found to be able to control taste and odor problems.
- **Aeration** is practical for removing the common characteristic rotten egg odor of hydrogen sulfide caused by iron and sulfur deposits that create iron or sulfur-reducing bacteria in a well. Aeration also works well for removing dissolved methane gas, which is a colorless, odorless, flammable gas formed by the anaerobic decomposition of organic matter. When mixed with water, it tastes like garlic.
- **Adsorption** methods for the removal of taste and odor are the addition of powdered activated carbon to the water or the use of granular activated carbon in the water filter.

Iron And Manganese

Iron and manganese enter the groundwater naturally as they are dissolved by water flowing downward through the soil and rock of the surrounding aquifer, or as iron or steel pipes corrode. Neither is considered a health hazard, but their presence can result in stained laundry, discolored plumbing fixtures, and offensive taste, odor, and color. The secondary standard for iron in drinking water is 0.3 milligrams per liter (mg/L) and for manganese it is 0.05 mg/L.

Appearance

Iron and manganese cause discolored water and build up in pipelines that reduce the quantity and pressure of the water supply. These minerals occur in water in a number of different forms:

Soluble iron – water with high levels of dissolved iron may appear red-brown with rust colored sludge. Water may also come out of the faucet clear, but turn red or brown after standing. This is ferrous iron, also commonly referred to as “clear-water” iron.

Insoluble iron – water that is red or yellow when first drawn is ferric iron, or “red-water” iron.

Soluble manganese – water with high levels of dissolved manganese may appear black-brown. Manganese often gives an oily sheen to the water’s surface, especially when heated (water heaters, coffee pots).

Insoluble manganese – may appear black-brown and includes slimy tar-like black particles.

Iron and manganese also promote the growth of bacteria. Iron and manganese bacteria may have the following effects:

- Unpleasant metallic taste and musty or swampy odors;
- Increased organic content that may trigger positive bacteria sample results;
- Formation of red/brown slimy deposits that may plug pipes, or break free in slugs of dirty, rusty water;
- Corroded piping and plumbing equipment; and
- Increased chlorine demand.

Taste

Iron and manganese cause a metallic or vinyl type taste in the water.

Odor

Iron bacteria don’t produce hydrogen sulfide, but creates an environment where sulfur bacteria can grow and produce hydrogen sulfide. The resulting gas tastes and smells like rotten eggs, is highly corrosive, and can eat away at metal piping and plumbing.

Methods Used to Control Iron and Manganese:

- *Oxidation, Precipitation, and Removal by Filtration* - oxygen content is low in deep wells, keeping iron and manganese dissolved. Oxygen in some form must be added to water to **oxidize** the dissolved minerals such as iron and manganese. This is done by aeration or by adding an oxidizing chemical to the water.
 - When combined with oxygen, chlorine, or potassium permanganate, oxidation will occur and iron and manganese will precipitate and can be filtered out.
 - Exposure to air changes iron and manganese from a colorless dissolved form to a colored solid form.
 - Manganese is more difficult to remove than iron because the reaction rate is slower during oxidation.
 - Iron can be more easily oxidized by aeration. Manganese is typically oxidized by chlorine or potassium permanganate.
 - After oxidation, the precipitated solids can be removed by filtration.
- *Sequestration* - a phosphate compound is fed into the water that will keep iron and manganese from oxidizing (see the phosphate section of this study guide). This works best for water that contains low levels of dissolved iron and manganese and no dissolved oxygen.
 - Sequestration is recommended for a concentration less than 1.0 mg/L of iron, manganese, or a combination of both.
 - Does not remove iron and manganese, just helps keep them in solution until water is exposed to air such as at the faucet.
 - Even with the addition of phosphate, iron and manganese can settle out in dead-ends or low use areas.
- *Ion Exchange* - this is a process that is generally used as a point-of-use softening appliance in the home or used in the industrial area where the water must be near zero hardness. A water softener is sometimes used in small systems to remove small quantities of iron and manganese, but may tend to clog the ion exchange media. (One grain per gallon of total hardness equals 17.1 ppm per grain of hardness.)
- *Other Methods* - lime softening and iron filtration are often used by larger systems. Also, drilling a new well into an aquifer with lower iron content is sometimes an alternative. Flush pipelines and eliminate dead-ends to remove sediment and reduce customer complaints.

Chemical Addition

Fluoride, chlorine, and phosphates are chemicals that are commonly used in a water system. These chemicals can be in powder, granular, gas, or liquid form. Operator safety, ease of handling, storage, feeding requirements, and cost are all factors in selecting the appropriate chemical for the water treatment desired.

- Chemical tank overflow pipes must be down turned, screened, and have a free fall discharge.
- Chemical feeders should be installed to operate only when the well pump turns on to prevent overfeed to the system.
- Chemicals are safe *if handled properly*. All operators should be trained in the proper methods of handling chemicals, detecting leaks, and emergency procedures.
- Each operator shall have at least one pair of rubber gloves, goggles or facemask, a dust respirator, protective clothing, and clean running water nearby in case of leaks or skin exposure. 
- Compressed air respiratory protection equipment (Self Contained Breathing Apparatus - SCBA), having at least 30 minutes capacity, shall be stored outside the chlorine room, and be readily available for properly trained personnel to use.



Phosphate Addition

Phosphate compounds are used as stabilizing chemicals in water treatment. Depending on what type of phosphate is used, phosphate compounds will inhibit interior pipe corrosion and/or sequester (tie up) iron and manganese. Phosphate addition will also act to:

- Chemically tie up the scale-forming ions of calcium and magnesium so that they cannot react to form excess scale on interior pipe walls.
- Prevent excess scale that clogs plumbing and increases head loss in the system.
- Protect the interior of pipes or tanks from pitting and the formation of tubercles.
- Inhibit corrosive water from picking up toxic metals such as copper or lead leached from service lines or solder.
- Reduce customer complaints of discolored water.

Phosphate for Corrosion Control

Phosphate compounds are used to form a protective film on interior pipe surfaces. The film prevents build-up of rust or scale on pipe walls and leaching of toxic metals into the water. The type of corrosion inhibitor used is dependent upon the characteristics of the water being treated.

- **Orthophosphate** – inhibits corrosion and is most effective in water with low hardness and a pH range of 7.1 - 7.8.
- **Polyphosphate** – sequesters iron and manganese and is well known for red/black water control (color sequestration) and prevents scale buildup.
- **Blended Ortho-Polyphosphate** – often referred to as zinc phosphate, it achieves treatment benefits of both orthophosphate and polyphosphate.
- **Sodium Silicate** – inhibits corrosion and sequesters (ties up) iron and manganese to reduce red/black water. An added benefit of silica is that it is not a nutrient for bacteria (phosphate is a nutrient) and; therefore, does not require that chlorination be implemented. Typical feed rates for silica are 8 - 20 ppm.

Sequestration

Sequestration is a chemical addition treatment process that controls scale by keeping iron and manganese in dissolved form. When phosphate is added to water, it sequesters, or holds in solution, scale-causing ions such as calcium, iron, and manganese, and prevents them from precipitating or forming scale in the system.

Chemicals are added to groundwater at the wellhead or at the pump intake before water has a chance to come in contact with air or chlorine. This ensures that the iron and manganese stay in soluble form. If the water contains less than 1.0 mg/L iron and less than 0.3 mg/L manganese, phosphate may prevent precipitation.

In general the following apply to sequestration chemicals:

- Chemicals should be purchased to supply the water system for a minimum of 30 days and are available in liquid or dry form.
- Product must be approved for potable water use. (Chemical must meet American Water Works Association [AWWA] and National Sanitation Foundation [NSF] International standards.)
- Concentrated solutions are slightly acidic so they must be stored in corrosion resistant tanks.
- Can be fed directly from the shipping container or day tank using a conventional metering pump and piping designed to handle corrosive material.
- Dosage depends on local conditions but will range between 0.5 and 3 mg/L for corrosion control. The dosage may go up to 10 mg/L.
- The phosphate feed point should be located immediately after the check valve to minimize oxidation of iron and manganese.
- Chlorine must be fed downstream from the phosphate feed point; otherwise, the chlorine will oxidize the iron and manganese before the phosphate sequesters them.
- Phosphate is a bacterial nutrient; therefore, 10 mg/L chlorine residual must be maintained in the storage tank.
- When using phosphate, a total chlorine residual of at least 1.0 mg/L and a free residual of 0.2 mg/L must be maintained in the distribution system to prevent the growth of bacteria.
- The ratio of mg/L of polyphosphate to mg/L of iron is in the range of 4:1.
- Feed pumps should be installed to operate only when the well pump is running.

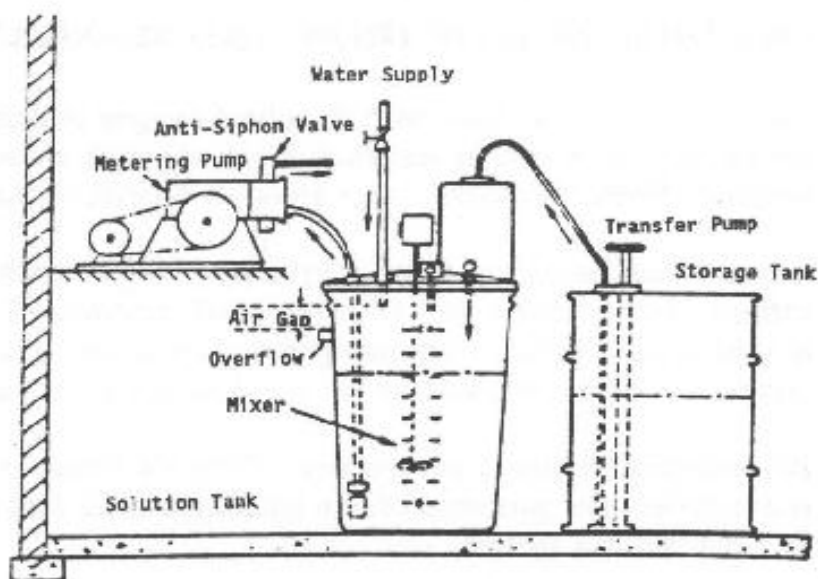

Maintenance and Safety

- Store chemicals in a clean and dry area that has good ventilation.
- Use a face shield, rubber apron, and rubber boots when working with chemical solutions. Clean up spills immediately to prevent accidental contact with other chemicals and equipment damage.
- Inspect storage tanks, dilution tanks, pumps, and piping routinely for leaks and make repairs immediately.
- Keep the chemical feed area clean.
- Protect storage tanks and solution from contamination. Storage tanks must be covered with sealed openings and fitted with over-lapping covers.
- Chemical feeders must have backflow prevention devices.
- Overflow lines must be turned downward with the end screened.
- Keep chemical storage tanks clean and free of debris.

Records

Smooth-nosed raw water sampling taps must be provided for analysis purposes, and analysis equipment must have the capacity to accurately measure the iron content to a minimum of 0.3 mg/L and the manganese content to a minimum of 0.05 mg/L.



Information to be recorded includes:

- Maintenance on feeders, solution lines, and diffusers;
- Daily chemical usage as mg/L, ppm, or GPD;
- Brand of chemical being used and concentration being fed;
- Quantity of water being treated as GPH, GPD, or MGD;
- Raw water analysis of iron and manganese concentration from each well; and
- Results of periodic analysis of distribution system iron and manganese concentration.

Disinfection

Disinfection is used to kill disease-causing microorganisms in the water system; therefore, it should not be confused with sterilization, which is the destruction of all living microorganisms.

- The most common and practical methods of disinfection in public water supplies are chlorination, ozonation, and the use of ultra-violet light.
- The disinfectant residual is the amount of chlorine that remains at end points in the distribution system and is measured as mg/L or ppm.
- Dose (initial feed rate) - Demand (consumed on the way) = Residual (end-point).
- Residuals must be measured in the field at sampling time. Chlorine dissipates quickly.
- Chlorination equipment shall be capable of keeping a free chlorine residual of 2 ppm for at least 30 minutes in the finished water at peak flow.
- Minimum residual chlorine levels of 0.2 – 0.5 ppm free chlorine or 1.0 ppm total chlorine should be maintained. Chlorine residuals (free or total) must not exceed 4.0 ppm.
- Both the chlorine residual and the contact time are essential for effective disinfection. It is important to have complete mixing. The operator also needs to be aware that changes in the pH may affect the ability of the chlorine to disinfect the water. The operator needs to understand:
 1. **Injection point** – whether the injection point and the method of mixing is designed so that the disinfectant can get into contact with all of the water to be disinfected.
 2. **Contact time** – expressed as CT value, the residual disinfectant “C” concentration in mg/L multiplied by the corresponding disinfectant contact “T” time in minutes. The “C” concentration of the chemical and the “T” length of contact time needed to adequately kill or inactivate pathogens vary with different types of disinfectant.
 3. **Effectiveness of upstream treatment processes** – the lower the turbidity (cloudiness) of the water, the more effective the disinfection.
 4. **Temperature** – at higher temperatures, the rate of disinfection is more rapid.
 5. **Dosage and type of chemical** – usually the higher the dose, the quicker the disinfection rate. The form of disinfectant (chloramines vs. free chlorine) and the type of chemical (gas vs. liquid) used influence the disinfection rate.
 6. **pH** – the lower the pH, the better the disinfection action.

When chlorine is initially added to water, the following may occur:

1. If the water contains iron, manganese, organic matter, or ammonia, the chlorine reacts with these materials and no residual is formed, meaning that no disinfection has taken place.
2. If additional chlorine is added at this point, it will react with the ammonia to form chloramines. The chloramines are considered a “combined” chlorine residual. As the chlorine is combined with other substances, it loses some of its disinfection strength. Combined residuals have less disinfection power than free (non-combined) residuals and may be the cause of taste and odor problems.
3. Some systems intentionally add ammonia to extend the life of the chlorine so residuals are carried to end-points in large distribution systems. The resulting combined chlorine is not as strong as free, but lasts longer.
4. With a little more chlorine added, the chloramines and some of the chlororganics are destroyed.
5. With still more chlorine added, free chlorine residual is formed, free in the sense that it can react quickly. Free also dissipates more quickly than combined.

Most chlorine analyses are performed with the DPD method. DPD reagent will change color in the presence of chlorine when added to a water sample. A manual color comparator (color wheel held up to the light) or a colorimeter (digital readout) that automatically measures the intensity of the color is used to determine the concentration of chlorine residual in the water sample.

Sodium Hypochlorite

Sodium hypochlorite is sold only as a liquid and may be referred to as liquid bleach. It is generally available in concentrations of 5 to 15 percent available chlorine. These solutions are clear, light yellow, strongly alkaline, and corrosive, in addition to having a strong chlorine smell.



High-test hypochlorites are relatively stable throughout production, packaging, distribution, and storage. Storage at 86°F for a year may reduce the available chlorine by as much as 10 percent. Storing at lower temperatures reduces the percent strength loss. All sodium-hypochlorite solutions are unstable to some degree and deteriorate more rapidly than dry compounds. Most producers recommend a shelf life of 60 to 90 days. Because light and heat accelerate decomposition, containers should be stored in a dry, cool, and dark area.



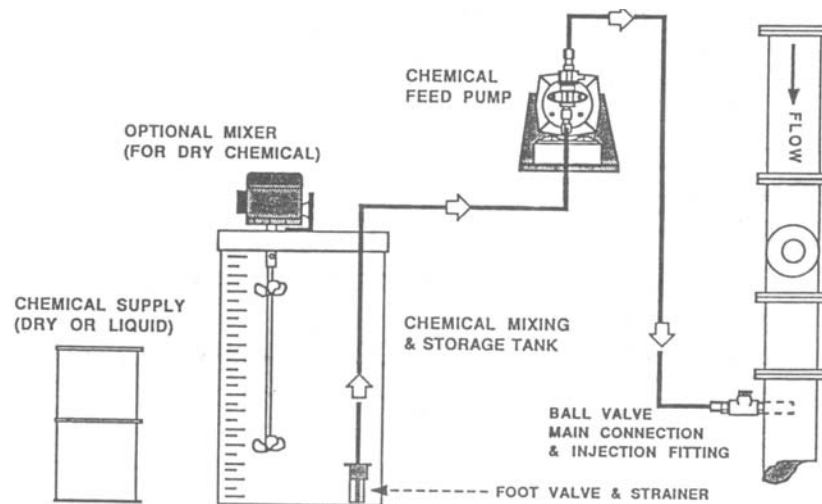

For hypochlorites to be mixed with water, a plastic storage tank is required. Tank sizes depend on the feed amount needed. Normally, tanks should hold at least a week's supply. The piece of equipment used to feed liquid chlorine is called a hypochlorinator. Hypochlorinators are used to dispense the chlorine solution made from hypochlorites into the water being treated. Hypochlorinators are usually a diaphragm pump similar to the type used to feed fluoride.

Gas Chlorine

- At room temperature, elemental chlorine is a greenish-yellow gas about 2½ times heavier than air; therefore, it will sink to the floor if released from its container.
- Chlorine gas is primarily a respiratory irritant and most persons can usually detect concentrations in the air above 1 ppm. Chlorine causes varying degrees of irritation of the skin, mucus membranes, and the respiratory system, depending on the concentration and the duration of exposure. Severe exposure can cause death, but the severe irritating effect makes it unlikely that anyone would remain in the chlorine-containing atmosphere unless trapped or unconscious.
- The equipment used to feed concentrations of 100% pure chlorine is called a chlorinator.
- Chlorine gas is removed from chlorine cylinders by a valve and piping arrangement to the chlorinator. In smaller plants, chlorine is withdrawn with a chlorinator installed directly on the cylinder.
 - The operating vacuum needed to pull the chlorine gas out of the cylinders is provided by a hydraulic injector. To get the necessary water pressure for the injector, a small booster pump may have to be installed in the water line to the injector. The water supplied by this injector absorbs the chlorine gas; the resulting chlorine solution is conveyed to a chlorine diffuser through a corrosion resistant pipe. A vacuum-regulator valve dampens feed water fluctuations for a smoother operation.

- The primary advantage of vacuum-feed operation is safety. If a failure or breakage occurs in the vacuum system, the chlorinator either stops the flow of chlorine or allows air to enter the vacuum system rather than allowing chlorine to escape into the surrounding atmosphere. In case the chlorine inlet shutoff fails, a vent valve discharges the incoming gas to the outside of the chlorine building.

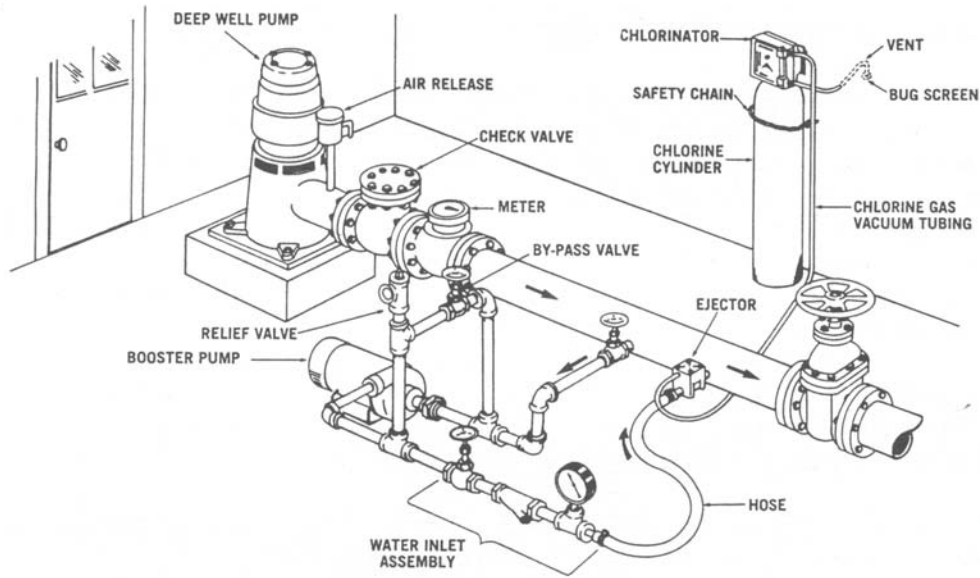

- The gas chlorine room shall be enclosed and separated from other operating areas. It shall have:

 - ✓ A shatterproof inspection window;
 - ✓ A locking door opening to the outside, equipped with panic hardware;
 - ✓ A power ventilation fan providing at least one room air exchange/minute (fan shall take suction from 6-12" above the floor, and discharge to atmosphere at least 6 feet above the ground outside);
 - ✓ A "Danger Chlorine" sign displayed on the outside of the door;
 - ✓ Cylinders isolated from the operating areas, chained in position, and stored separate from ammonia storage;
 - ✓ Switches for fans and lights outside the room at the door and window (switches shall be protected from vandalism);
 - ✓ Vents from the feeders and storage discharging to the outside above grade;
 - ✓ Chlorine gas lines that do not carry chlorine gas beyond the chlorine room; and
 - ✓ Heat to approximately 60°F throughout the chlorine room.

The following are safety procedures that should be observed when moving cylinders:

1. Always replace the protective cap when moving a cylinder.
 2. Move cylinders with a properly balanced hand truck that has supports that fasten around the cylinder two-thirds of the way up on the cylinder.
 3. The 250-pound cylinder can be rolled in a vertical position. Avoid lifting these cylinders except with approved equipment. Use a lifting clamp, cradle, or carrier. Never lift with homemade chain devices, rope slings, or magnetic hoists and never lift the cylinder by its protective cap.
 4. Keep cylinders away from direct heat and direct sunlight.
 5. Firmly secure cylinders upright to a fixed object when stored or in use.
 6. Store empty cylinders separately from full cylinders, and label them clearly with information as to whether they are full or empty.
- The operator should use only the fittings and gaskets furnished by the chlorine supplier or chlorinator manufacturer when making connections to chlorine containers. The outlet of a container valve has special threads. Regular pipe thread fittings should not be used. A new lead gasket should always be used when making a new connection. The outlet threads on the container valve should always be inspected before being connected to the chlorine system. Containers with badly worn threads should be returned to the supplier. If a connecting nut is used, it should be inspected for corrosion. Since the threads on both the tank and the connecting nut could be worn, the use of a connecting yoke is recommended.
 - Leak-detection procedures should be followed after any connection of cylinders in the system. The connections should be checked with a 60% ammonia solution by applying only the vapors, not the liquid, near the connections to the tank. If a leak is present, a white smoky vapor will be given off from the leak.
 - A fusible plug is placed in the valve below the valve seat as a safety device. The plug is set to melt at 158°F to 165°F to prevent buildup of pressure and the possibility of rupture due to a fire or high surrounding temperatures. Increasing the room temperature causes an increase in tank pressure.
 - Floor drains are discouraged in the chlorine room. Where provided, the floor drains shall discharge to the outside and shall not be connected to other internal or external drains.
 - There shall be chlorination standby equipment for the protection of the supply.

Fluoridation

Fluoride in drinking water is used to prevent dental decay. When added in the proper amounts, fluoride has been shown to reduce cavities and promote strong teeth in children.



- All municipal water systems in Minnesota are required by state regulations to fluoridate the drinking water supply. The monthly average fluoride concentration must be between 0.9 mg/L and 1.5 mg/L, with an optimum level of 1.2 mg/L.
- Too much fluoride in drinking water can cause dental fluorosis or mottling of teeth. At higher levels, bone disease may result. The Federal Safe Drinking Water Act has established a maximum contaminant level (MCL) of 4.0 mg/L to prevent bone disease and a secondary standard of 2.0 mg/L to prevent mottling of teeth.
- Monthly reports of daily sample results must be submitted to the MDH within 10 days of the end of each month. For example: June's daily feed report must be at MDH by July 10. In addition to reports of daily results, systems must also submit one (1) fluoride sample each quarter (one every three months) to the MDH lab.
- Samples must be taken from treated water in the distribution system and at different locations each day.
- The raw water fluoride concentration should be tested monthly.

Fluoride Compounds

- Fluoride compounds used are hydrofluosilicic acid (H_2SiF_6), sodium fluoride (NaF), and sodium silicofluoride (Na_2SiF_6). Hydrofluosilicic acid is the most commonly used fluoridation compound.
- Hydrofluosilicic acid must be handled cautiously. It is very acidic and can cause burns. It produces dangerous acid fumes that must be vented to the atmosphere to prevent irritation to the skin. These acid fumes can etch glass on gauges and corrode electrical equipment.

- **CAUTION** Always add acid to water!!! Never the reverse. Add acid to water while stirring gently to prevent the generation of steam, hot water, and bubbling acid, which could boil over the container and cause serious acid burns.

Fluoridation Systems

Fluoride can be added to water in liquid or powder form. In liquid form, a chemical pump adds the fluoride in a controlled dosage. In powder form, a dry feeder combines the chemical with water. The resulting solution is added in a controlled dosage.

Hydrofluosilicic Acid Feed

A typical hydrofluosilicic feed system includes:

- A dual head positive displacement pump: designed of a corrosion-resistant material. If the pump discharges to an open tank with an air break, the dual-head pump is not required. The air break will prevent any chance of back-siphonage.
- A break box: if an air break is not provided, a break box must be used to prevent overfeed of fluoride chemical. This is a single compartment box with one head of the feed pump discharging chemical into it, and the second pump head taking suction from it and discharging to the feed point. This box must be made from acid resistant material that can withstand the corrosion of the hydrofluosilicic acid. This assembly must have an overflow line back to the day tank. Corrosion-resistant shelving should be used for mounting the feed system.
- A day tank: the solution or day tank is generally a calibrated polyethylene tank that can withstand the corrosiveness of an acid. This tank generally holds at least 50 gallons of fluoride solution. It should be calibrated in one gallon units. The solution tank should be covered and vented to the outside.
- When hydrofluosilicic acid is used, the point of application in a horizontal pipe shall be in the lower half of the pipe and should be angled up.

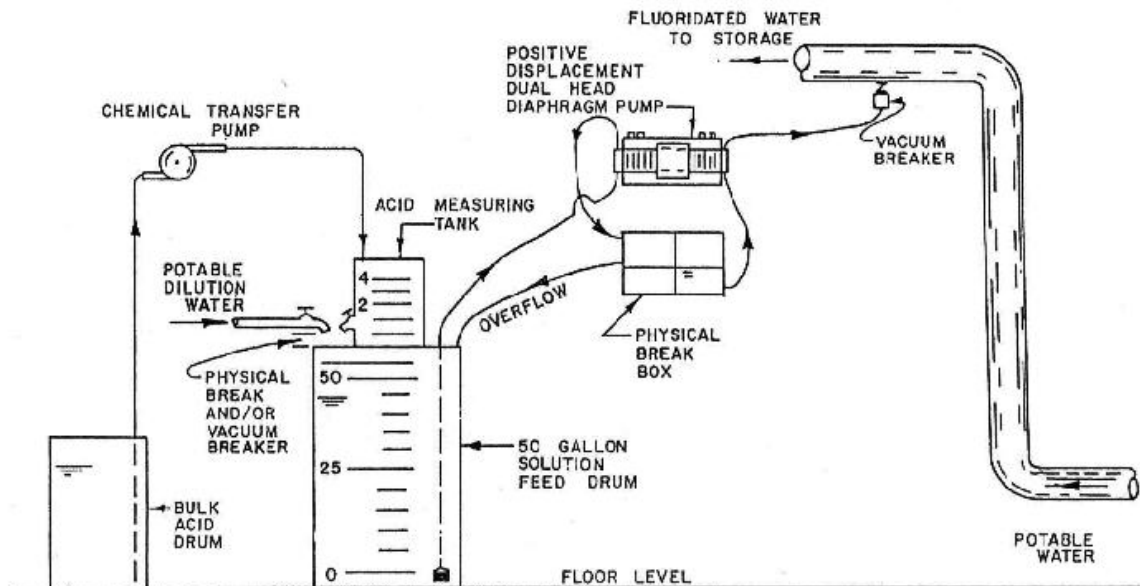

Corrosion

Corrosive drinking water causes internal corrosion of piping; corrosive soils and moisture cause external corrosion of piping.

Problems that can be created by corrosion include:

- Need to replace watermains;
- Reduced carrying capacity of mains;
- Reduction of system pressure;
- Increased pump energy costs;
- Increased customer complaints resulting from rusty water, stained laundry, and bad tastes;
- Increased pathogens; and
- Leaks.

Factors That Affect Corrosion Include:

Physical Factors

- Type and arrangement of pipe materials in the system;
- Presence of stray electrical current;
- Water flow velocity; and
- Temperature.

Chemical Factors

- **pH** – when water has a low pH ($\text{pH} < 7$), it will be more corrosive. Water with a high pH (> 7) is more protective of pipe materials. Water with a very high pH may deposit excess scale.
- **Chlorine residual** – water with low or no chlorine residual may allow biofilm to grow on the pipe wall. This may cause the pH to drop and make the water more corrosive.
- **Total dissolved solids (TDS)** – dissolved substances in water have electrical charges that allow water to conduct electricity. The more TDS in water, the greater the electrical conductivity.
- **Dissolved gases** – oxygen, carbon dioxide, and hydrogen sulfide.
- **Dissolved metals** – copper, lead, iron, and zinc can cause water to discolor and can be toxic.

Biological Factors

- Biological factors increase the rate of corrosion by decreasing the pH and forming objectionable corrosion by-products.
- **Iron bacteria** produce red or brown colored slime masses on pipe walls that release during periods of high water flow velocity causing “red water.”
- Iron, and other mineral deposits, protect bacteria from residual chlorine and allow them to multiply.
- Pressure or velocity changes in the main can cause bacteria to be released into drinking water.
- **Sulfate reducing bacteria** produce a rotten egg odor and deposit black metallic looking sulfides on interior pipe walls. This type of bacteria is extremely corrosive to metals.

Interior Corrosion

Interior corrosion and the formation of tubercles that reduce the carrying capacity of the pipe are major problems in iron (ferrous) piping materials. Complaints of red water, greenish water, dirty water, laundry stains, and loss of pressure are examples of indicators of interior corrosion.

Causes of interior corrosion:

- Low water usage or velocities create a longer contact time between water and the pipe, resulting in a higher metal pickup.
- The warmer the water, the faster metals from the piping material leach into the water resulting in higher lead, copper, or iron levels.
- High velocities will cause rapid pipe corrosion by thinning the pipe wall (erosion corrosion).
- Dissolved oxygen in water increases the rate of pipe corrosion.
- Hydrogen sulfide causes corrosion (water heaters).
- Hard water may deposit scale on pipe walls that will reduce the carrying capacity of water mains.
- Tuberculation reduces the inside pipe diameter. Tubercles (mounds of rust deposits) on the inside of iron pipe increases the roughness of the pipe, increases resistance to water flow, and decreases carrying capacity of mains.



Copper Corrosion

- Copper staining (greenish or bluish staining on plumbing fixtures and a blue-green water color) indicates highly corrosive or aggressive water.
- Water that contains too much carbon dioxide, oxygen, or natural mineral acids, eats away at brass and copper plumbing fixtures.
- Corrosive or aggressive water will cause pinhole leaks in copper piping.
- Soft water is more corrosive because it reduces or eliminates the protective calcium carbonate or other mineral coatings on pipe walls.



SOLUTIONS

Water that is corrosive may be treated by:

- pH adjustment – raise pH to produce a thin protective calcium carbonate coating.
- Annual system wide flushing, unidirectional flushing, dead-end flushing, and routine flushing of problem areas.
- Avoiding dead-end mains (looping).
- Change tower levels and well flow seasonally. This will ensure complete system turnover every 2-3 days and keep water in the distribution system fresh.
- Phosphate or silicate addition – adding a corrosion inhibitor slows the rate of internal corrosion by forming a thin protective coating on pipe walls.

Exterior Corrosion

Causes of exterior corrosion:

- Electrolysis – contact with moist soil (water conducts electricity) or low pH soil (acidic and corrosive).
- Galvanic – joining dissimilar metals such as copper to iron pipe. The difference of each pipe's electric potential causes a flow of current, which results in corrosion.
- Stray current – grounding of electrical current to water pipes.

In order for exterior corrosion to occur, there must be four elements:

- Electrolyte (soil);
- Anode (where electric current leaves the pipe);
- Cathode (where electric current goes to); and
- A return electrical current (path of current from anode to cathode).

Example of electrolysis corrosion:

Iron pipe is laid in clay soil.

- Electric current flows through soil (electrolyte) from the anode portion of the pipe (*i.e.*, the portion where the current leaves the pipe) to another area that is called the cathode portion of the pipe.
- Corrosion occurs where the current leaves the pipe (at the anode).
- The cathode portion of the pipe is protected from corrosion by the electrical current applied to it from the anode section of the pipe.
- The flow of current is caused by the voltage potential difference between the anode portion of the pipe and the cathode portion. The electrolyte (in this case the clay soil) has a low resistivity (electrical current flows relatively freely through it).

Example of galvanic corrosion:

Iron pipe is connected to copper in sandy soil.

- The iron portion of the pipe has greater voltage potential than the copper portion.
- Electric current flows through soil (electrolyte) from the anode (iron) portion of pipe to the cathode (copper) portion of pipe.
- Corrosion occurs at the iron portion where the current leaves the pipe.
- The copper section of pipe is protected from corrosion by current applied to it from the anode (iron) section of pipe. The electrolyte (in this case the sandy soil) has a high resistivity (electrical current does not travel freely through it).





SOLUTIONS

- Cathodic protection – this method involves attaching cathodes (negatively charged metals) or anodes (positively charged metals) to the pipe. These charged metals will corrode instead of the pipe. The anodes or cathodes introduce a current to the pipe. This changes the current flow from the pipe and causes it to flow from the anode to the cathode.
- Install PVC, cement, or bituminous-coated pipe.
- Wrap pipe in plastic sheeting before burying.

Pipe Cleaning

Mechanical cleaning may be necessary in areas where excessive tuberculation and deposits are found in older cast iron pipes, or where iron bacteria and slime growths are a severe problem. When a flushing program doesn't adequately increase the carrying capacity of a pipe, air purging or cleaning devices should be used to clean the water main.

- Air purging – air mixed with water is used to clean small mains (up to 4-inch).
- Foam swabs – forced through the mains by water pressure. This will not significantly remove the hardened tuberculation and wears out quickly. 
- Polyurethane pigs – stiff, bullet-shaped plugs similar to swabs, but harder, less flexible, and more durable. These remove harder encrustation. 

Entry and exit points for swabs or pigs include:

- Fire hydrants;
- Wyes;
- Tees; and
- Air relief valves.

Cleaning procedure:

- Pipe cleaning methods should start at the beginning of the system (well house, water plant, or tower) and move outward to the end of the distribution system.
- During the mechanical cleaning process, customer service lines in the affected area must be shut off.
- Clean the main, thoroughly flush the cleaned main, disinfect the main, and place the main and customer's lines back in service.

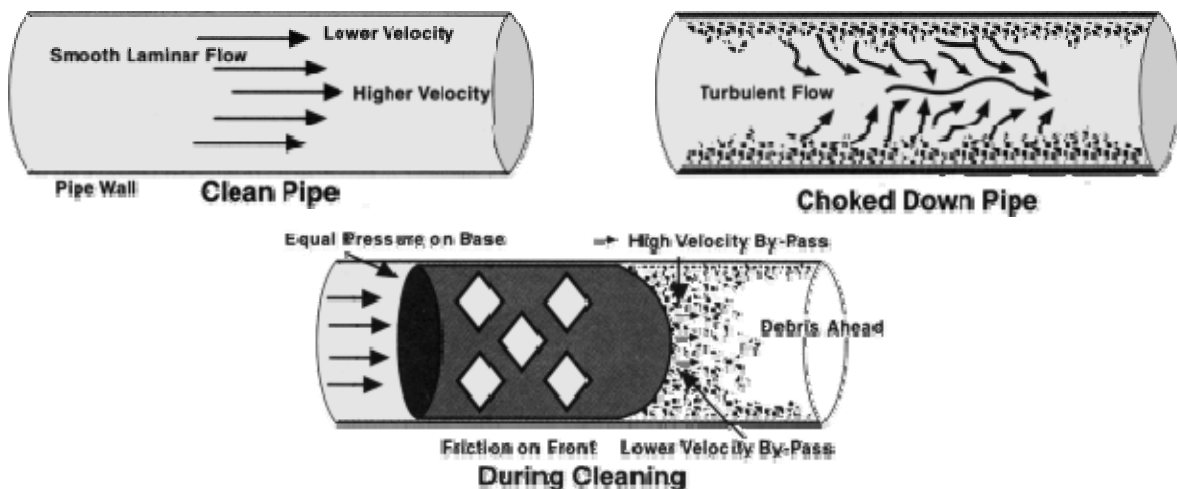

Photos courtesy of Girard Industries, Houston, TX

Distribution

A water distribution system consists of tanks and pipes that store and deliver treated water to consumers. The system consists of a network of pipes, valves, fire hydrants, service lines, meters, and pumping stations.



- Ductile iron pipe was introduced in the mid-1950s as a replacement for cast iron pipe. It resembles cast iron pipe in appearance and has many of the characteristics of cast iron although it is less brittle, more flexible, and will not break as easily as the cast iron pipe. Ductile iron is more corrosion resistant than cast iron and will resist bending and twisting without breaking.
- Common pipe connections are:
 - Push-on bell and spigot
 - Easy to use.
 - Saves time and labor.
 - Ball and socket joint
 - Underwater installations such as rivers or swamps.
 - Flexible joint allows deflection.
 - Sleeve joint
 - Iron coupling.
 - Allows moderate deflection and spans short gaps.
- Pipe locations should be selected to:
 - Provide a straight-line alignment where possible.
 - Match a standard pattern applicable to the entire system, such as the watermain being located on the north or east sides of the street and the sewers on the south or west sides.
 - Be readily accessible for maintenance, repair, or replacement with minimum damage to existing streets and other underground utilities.
 - Avoid conflict, contamination, and possible cross connection with sanitary sewers.
 - Provide protection from physical damage due to freezing and other weather conditions. In Minnesota, the pipe should be buried at least 7 feet below the ground surface to prevent it from freezing.
- All water mains shall be designed to maintain a minimum pressure of 20 psi at all points in the distribution system under all conditions of flow including fire. The normal working pressure should be approximately 60 to 80 psi and not less than 35 psi. If the pressure is above 100 psi, pressure-reducing devices shall be provided.



- The minimum pipe size shall be 6 inches for fire protection.
- Eliminate cross connections in the plumbing system to prevent contaminants from entering the potable water supply.

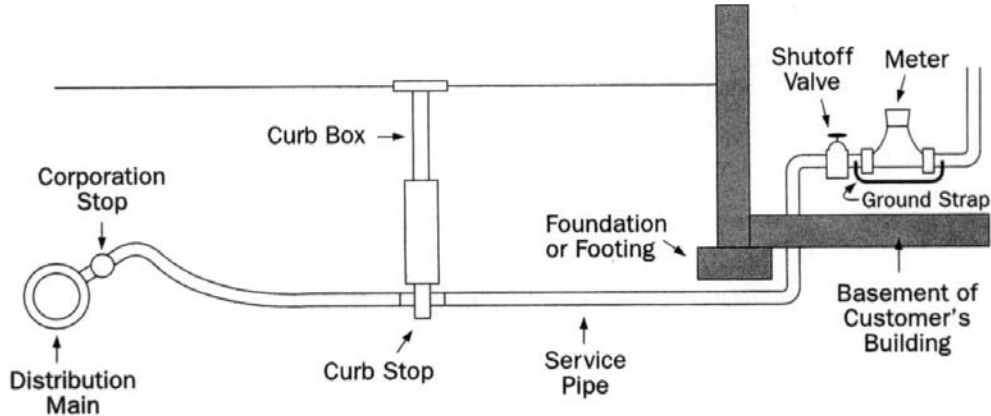

Figure 12-1 Small service connection with the meter located in a basement

- Dead ends result in stagnant water that deteriorates and can affect water quality throughout the system. Dead ends shall be minimized by looping the water main system.
- Any newly installed pipe shall be pressure tested for leaks, disinfected with 50 ppm of free chlorine residual for 24 hours, with a 10 ppm residual remaining at the end of the time period. The disinfecting agent should be introduced into the main through a corporation stop at the top of the pipe and at the beginning of the new line. Water from the existing system or another suitable source should flow into the new pipeline during the application of the chlorine. It shall then be flushed and tested for bacteriological safety. Bacteria results must be negative before the new pipe is ready for service.
- Pressure should be tested at 150 psi or 2½ times the normal operating pressure. This will disclose faulty pipes, bad joints, breaks, and other major defects. All pressures are to be measured at the lowest point of the line being tested. The duration of the test should be no less than two hours and need not exceed 24 hours.
- Repaired mains should be disinfected and flushed.
- Valves shall be located not more than 500 feet apart in commercial districts and 800 feet apart in other areas. Hydrant spacing may range from 350 to 600 feet depending on location.
- Hydrant drains should be plugged when located in the water table and barrels pumped dry before freezing weather. If drains are plugged, a gravel pocket shall be provided. The drain shall not be closer than 10 feet to a sewer.
- All tees, bends, and hydrants shall be provided with reaction blocking, tie rods, or joints designed to prevent movement.

- Watermains shall be laid 10 feet horizontally from an existing or proposed sewer. Exceptions may be allowed if the main is laid in a separate trench and the bottom of the main is at least 18 inches above the top of the sewer.
- Watermains crossing sewers shall be separated by a minimum vertical distance of 18 inches. If the vertical separation cannot be obtained, the sewer shall be constructed of materials and with joints that are equivalent to watermain standards, and shall be pressure tested prior to backfilling.
- Watermains must be located at least 10 feet from a sanitary sewer forcemain.
- Valves and fire hydrants should be exercised annually to ensure that they will work properly when needed.

Valves

Valves are used to shut off or throttle flow, maintain pressure, and isolate sections for repair and maintenance.

- Gate Valves:
 - Have a non-rising stem that moves the “gate” into the bonnet creating an unobstructed waterway when opened;
 - Have a gate that rises and lowers perpendicular to flow;
 - Are not well adapted for throttling flow;
 - Are the most common type of valve used for underground applications in the distribution system; and
 - Large gate valves, 14 inches and above, are installed with a smaller by-pass valve to reduce the pressure differential when opening or closing the valve.

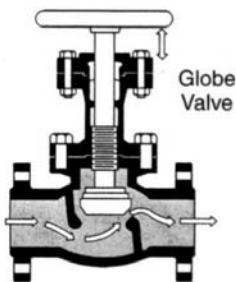
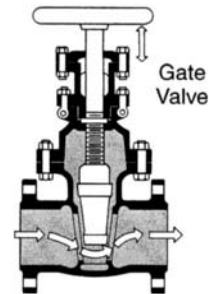

- Globe Valves:
 - Have a horizontal disc that moves up and down on the stem parallel with the flow;
 - Reduce chances that sediment or other obstructions will interfere with operation;
 - Are generally used in piping 3 inches or smaller; and
 - Restrict water flow as water passes through the valve.

- Butterfly Valves:

- Are used in throttling flows and automatic controls;
- Are sometimes used in place of gate valves;
- The shaft and vane is perpendicular to the flow; and
- Water pressure tends to keep the valve disc in the closed position.

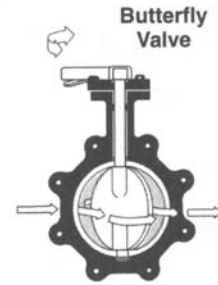

- Check Valves:

- Are used to prevent water from flowing in the opposite direction of normal flow; and
- Horizontal swing gates are used in wells to prevent water from flowing back down into the well when the pump has been shut off.
- Good locations for check valves include:
 - In front of the chlorine injection point, to prevent chlorinated water from going back into the lake or well;
 - Preceding the lake pump (when using a jet pump) to prevent the pump from losing its prime;
 - On the top of a submersible pump to prevent backflow from causing back spin of the impellers;
 - In front of the storage tanks to keep water from flowing backwards through the bag filter; and
 - After the storage tanks and before the booster pump to keep the booster pump from losing its prime.

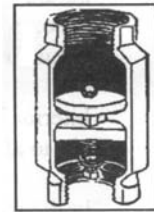

Foot Valve

- Foot Valves

- A foot valve keeps the suction pipe below the pump full of water when there is no pumping action. This valve prevents the line from draining, which would cause the pump to draw air and lose prime when it starts up again.

- Pressure Reducing Valves

- Pressure reducing valves are used to relieve fluctuating water system pressures. This helps protect fixtures from being damaged due to high water pressure.



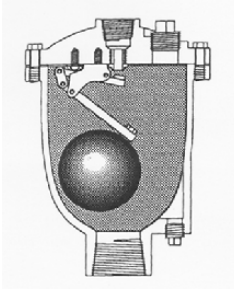

- Air Release and Vacuum Valves:
 - Are located at the top of the pipe to release accumulated air from watermains;
 - Vent air from the well casing to the atmosphere; and
 - Prevent pump cavitation.

- Ball Valves

- Ball valves are used as shut-off and throttling valves. This type of valve provides positive shut-off and quick closing with a ¼ turn of the valve stem. Ball valves are commonly used as a curbstop or shutoff on a water service line.

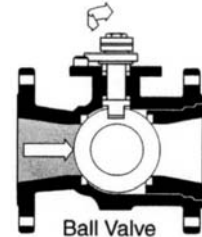

Valve Operation and Maintenance

- The location of each valve should be recorded on an as-built map for easy location during emergencies.
- Valve records should indicate normal position (open or closed) and number of turns required to operate.
- The valve covers should not be buried under pavement in the street.
- Valves should be operated at least once per year.
- Debris should be removed when found in the valve box.
- Valves should be opened slowly and closed slowly to prevent rapid movement of water in the pipes that can cause “water hammer.”



Valve and Hydrant Map



Valve Turning

Meters



Meter registers record either gallons or cubic feet of water usage. The three basic types of meters are displacement, velocity, and compound.

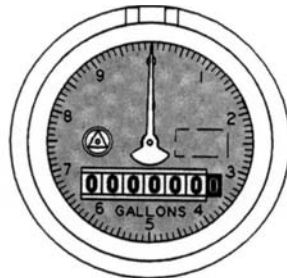

Straight Meter Register
Reading in Gallons

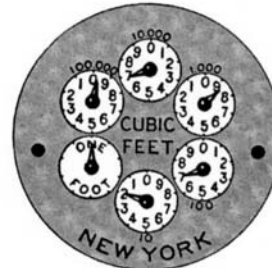

Circular Meter Register
Reading in Cubic Feet

Courtesy of Schlumberger Industries Water Division.

Figure 13-14 Meter registers

- Displacement Meters
 - Most common residential service meter.
 - Capable of measuring small flows with relatively high accuracy.
 - “Disc” meter measures water by nodding or nutating motion within the chamber.

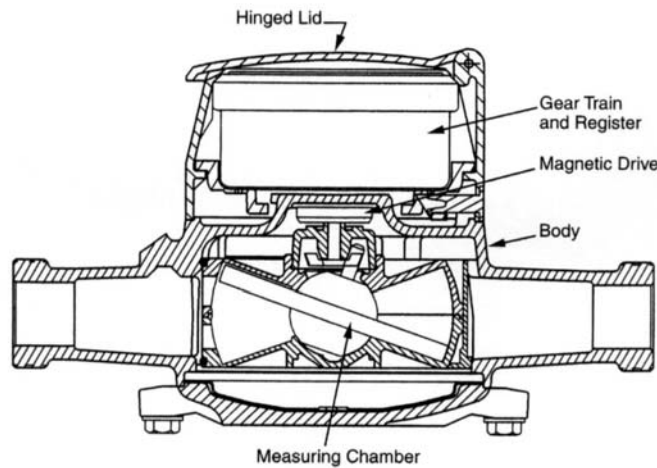

Courtesy of Schlumberger Industries Water Division.

Figure 13-1 Nutating-disk meter with a plastic housing

- Water flowing through the meter is measured by counting the number of times the chamber is filled and emptied.

- Excessive wear and inaccurate registration occur when displacement meters are operated in excess of their capacities.
 - Designed for cold climates with a frost protective bottom plate that splits when frozen.
 - The maintenance of positive displacement meters consists of temporarily removing them from the customers' service, taking them apart, and thoroughly cleaning and inspecting all parts. Defective and badly worn parts should be replaced. Worn meters tend to under-register water usage.
- Velocity Meters
 - A velocity meter or current meter registers the volume of water passing through it by measuring the velocity of the flow within a known cross-sectional area.
 - Two basic types are the turbine and propeller meters.
 1. Turbine Meter
 - Most commonly used for commercial buildings.
 - Measure relatively high flows with high accuracy.
 - The meter inlet should be located at least three pipe diameters from the nearest fitting.
 - Five pipe diameters of straight pipe at minimum should be on the discharge side of the meter.

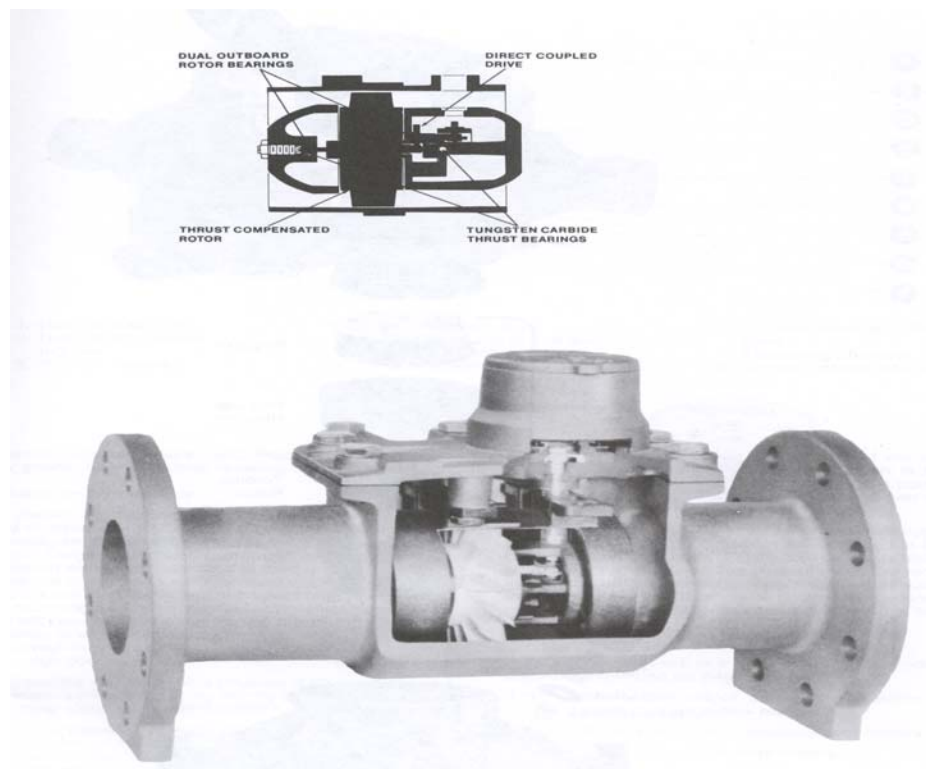

2. Propeller Meter

- Most common for well or plant raw water influent lines.
- Propeller meters are generally less accurate than a turbine meter.
- The propeller is placed inside the pipe and is revolved by water flowing past it.
- Friction losses are less in the propeller meter than the turbine meter.

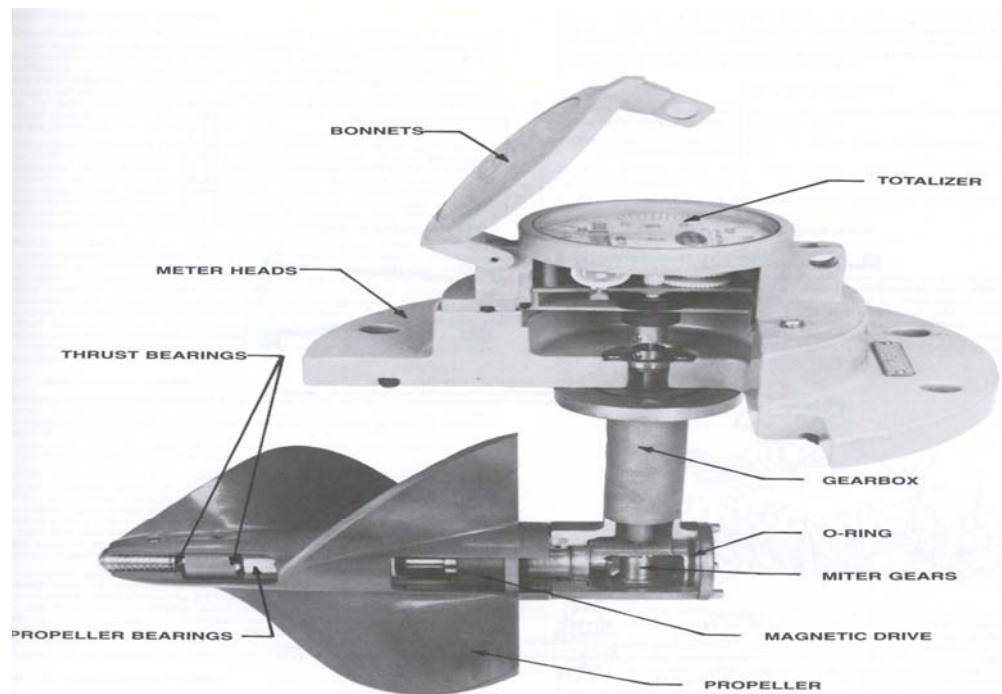
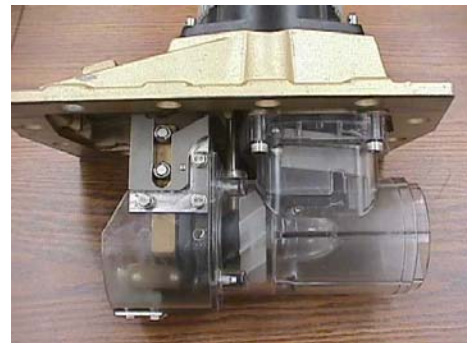

Fig. 3.62 Propeller meter
(Permission of Water Specialties Corporation)

- Compound Meters
 - Most common at hotels and apartment buildings.
 - A compound meter is used when the customers' water use fluctuates regularly over a wide range. This meter has a turbine section for high flows and a displacement section for low flows.



Meter Records

Any record system should provide such basic data as the date of purchase, size, make, type, location of meter, and the data on all tests and repairs.

Hydrants

Hydrants are located throughout the water system to provide for fire protection, and provide a means for maintaining water quality in the system. Hydrant types include:

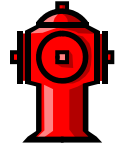

Corey or toggle type – this type of hydrant opens with the flow.

Compression type hydrants – this type of hydrant opens against the flow. Cold climates use the “dry-barrel” type hydrant. This type of hydrant has a below ground operating valve which allows that barrel to drain after use (if not plugged) to prevent freezing.

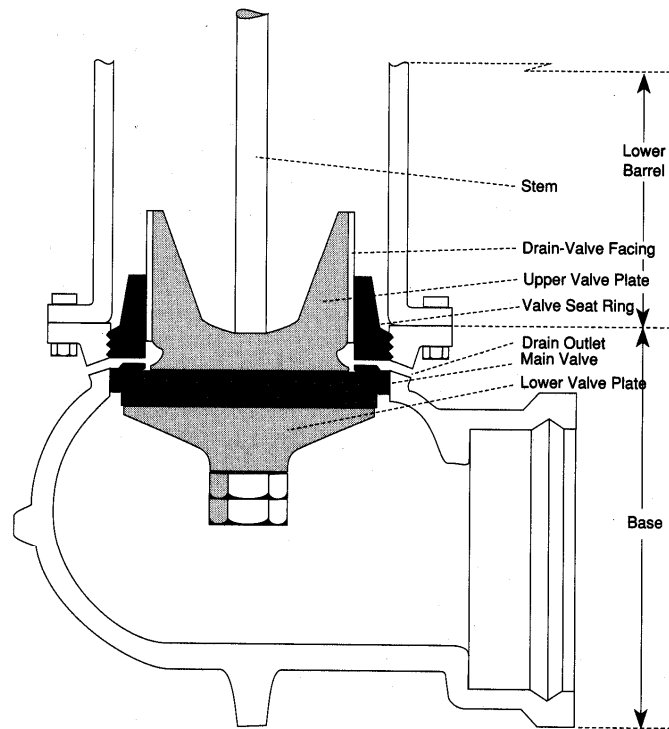

| Compression-type hydrant, opens against pressure.

- The length of the hydrant is referred to as the depth of bury and is the distance from the surface of the ground to the bottom of the inlet pipe.
- The hydrant barrel is ductile iron and the wear points are corrosion-resistant bronze.
- The most common threads used in Minnesota are the National Standard threads.
- The size of the fire hydrant refers to the size of the valve opening. For example, a 6-inch hydrant has a 6-inch main valve. The most common hose connectors on a hydrant are two 2.5-inch nozzles and one 4-inch steamer nozzle.
- In general, hydrants should be spaced at 500 to 600 foot intervals in average-value areas and at 300-foot intervals in high-value areas.

Yard hydrants – can only be used when permitted by the administrative authority and must be 10 feet from sewers and at least 2 feet above the water table.



- It is recommended that any new yard hydrant comply with the American Society of Sanitary Engineers (ASSE) Standard 1057 for sanitary yard hydrants.
- Yard hydrants with hose connections need to have an approved backflow preventer.
- These hydrants aren't intended to be used under continuous pressure and cannot be left in the open position long term.
 - The standard frost proof yard hydrant has a below ground stop and waste valve that allows the water in the hydrant to drain back into the ground when the valve is closed to prevent freezing.
 - The freezeless sanitary yard hydrant has a built-in reservoir that the water drains back into, instead of having an opening below ground. The water in the reservoir is flushed out each time you use the hydrant.

The correct hydrant maintenance inspection procedure should include the following:

- The hydrant should be checked for leaks.
- It should be operated and flushed, its ease or difficulty of operation noted, and any worn parts fixed.
- The condition of the drain valve, operating nut, nozzle caps, chains, packing, and paint should be noted.
- After operation and closure, check to see if the barrel drains properly.
- When lubricating the hydrant, use food-grade quality lubricant, not motor oil.
- Proper ground clearance from the nozzle cap to the ground surface should be maintained.
- Each hydrant should have its own isolation valve. Valves should be inspected and maintained annually.

Hydrants are designed for emergency use and should be inspected at least once per year to ensure the correct operation.

- Inspection is often performed in conjunction with a flushing program.
- Should not be used to regularly fill tanks.
- Should never be used with the valve partially opened or throttled.
- Should be opened slowly and fully, and closed the same. The operating nut should be turned back approximately 1/2-1 full turn to the open position to free the stem from any tension.

- Hydrant flushing
 - Regular flushing is important to keep the pipelines clean.
 - When flushing, the velocity of the water should be at least 2.5 feet per second to sweep out material accumulated in the piping. (Open all the way!)
- Flow testing
 - Determines the ability of the distribution system to provide enough water for fire protection.
 - The flow test is performed by opening one or more hydrants and measuring the flow with a pitot gauge.

Cross Connections and Backflow Prevention

A cross connection is a connection of a non-potable water source and a potable source. Cross connections and backflow can contaminate drinking water and cause illness. Backflow is unwanted, reversed flow of liquid in a piping system. There are two types of backflow.

1. **Back-siphonage** backflow occurs when there is a partial vacuum in a water system, which draws water from a contaminated source.
 - For example: during a large fire a pumper is connected to a hydrant. As a result, high flows drawn from the distribution system can significantly reduce the water pressure around the withdrawal point. Because of this, it is possible to create a partial vacuum in another point of the system, causing suction and drainage of contaminated water into the potable water system.
2. **Backpressure** backflow occurs when the pressure of the non-potable system exceeds the positive pressure in the water distribution lines.
 - For example: there is a potable water connection to a hot water boiler system. If pressure in the boiler system increases to a point that it is higher than the pressure in the distribution system, a backflow of contaminated water from the boiler to the potable water system may occur.

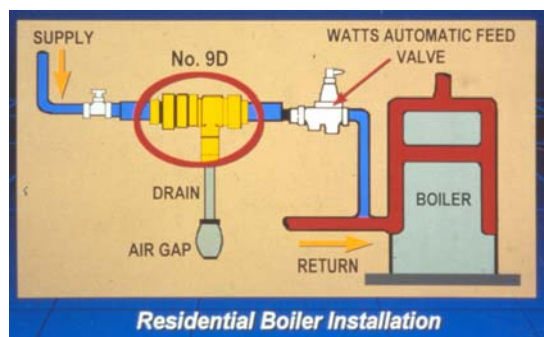
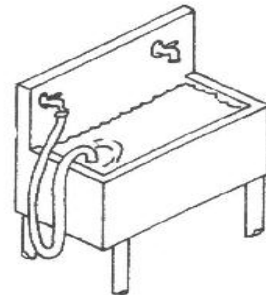

Some key points to cross connection control are:

- Eliminate direct connections between potable and nonpotable systems by using air gaps or installing approved backflow prevention control devices.
- Design piping systems in the potable water distribution system so that enough water at the desired pressure is always available.
- Maintain the distribution system to minimize pressure fluctuations. Prevent any connections that could allow the entry of contaminants unless a proper backflow prevention device is provided.
- Repair water main breaks immediately and disinfect repaired lines.
- Maintain all backflow preventers in good working order and have them tested regularly.
- Always be aware of the potential for contamination due to cross connections from hospitals, factories, or other industrial facilities.
- Stay alert during a large fire for possible problems with low-pressure areas. Water pressure may be reduced in the distribution system and create back-siphonage.
- Eliminate private well connections to public water supplies.

Water loading stations present a backflow hazard because fill lines may be used to fill potable water tanks, or contaminated vessels such as fertilizer tanks. Water loading stations shall have:

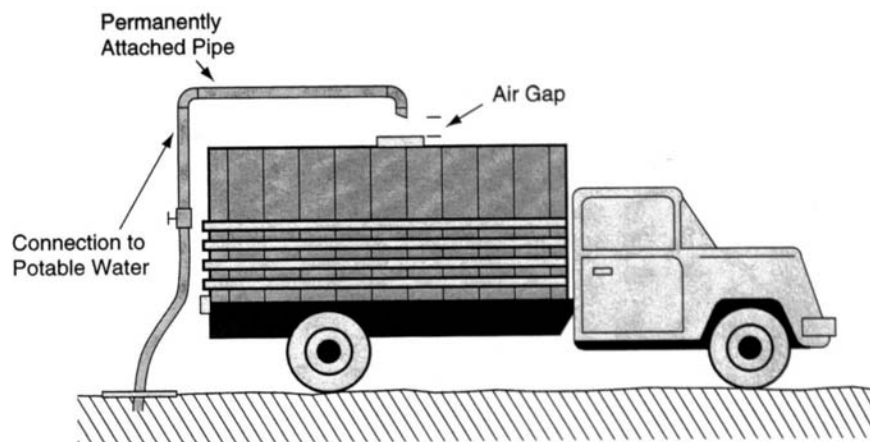

Figure 14-5 Water truck cross-connection prevented by air gap

- An air break or a backflow prevention device installed on the fill line;
- The fill hose and cross connection control device constructed so that when hanging freely, it terminates at least 2 feet above the ground surface; and
- The discharge end of the fill line unthreaded so that no additional hoses or piping can be attached to it.

Devices Used to Protect Against Cross Connections

- Air gap – physical separation of the potable and non-potable system by an air space.
 - Most positive backflow prevention measure.
 - Vertical distance between the supply pipe and the flood-level rim should be two times the diameter of the supply pipe, but never less than one inch. Example: a three-inch fill line times two pipe diameters equals a six-inch air gap.



- Atmospheric vacuum breakers – these devices are usually used with hose bibs to which a hose is attached and there is no backpressure.



- Pressure-type vacuum breakers – can be used under continuous pressure. They must be installed at least 12 inches above the usage point to prevent back-siphonage.



- Double check valves – these devices are used for a direct connection between two separate potable water systems.



- Reduced pressure zone backflow preventer (RPZ) – this device provides the greatest protection against backflow caused by backpressure and back-siphonage. The RPZ should be used where continuous pressure or high hazard conditions exist, such as at canneries or mortuaries. These devices must be tested annually and internal parts replaced every 5 years.



Pumps

Many different types of pumps can be used with the selection depending on the work that needs to be done. Pump selection depends on the maximum flow needed in gallons per minute (gpm) and the head it needs to pump against.

System Pressure and Head

Head is a measurement of the pressure or force exerted by the water. Head is expressed in feet to represent the height of the water above some reference point such as a gauge.

Pressure Head is the amount of energy in water due to pressure. The reading of a pressure gauge can be converted to feet of water by multiplying it by 2.31. For example, the gauge reads 52 psi x 2.31 = 120 feet of head (water above the gauge).

Lift, or suction lift, is the vertical distance in feet from the water surface to the pump, plus friction losses in the pipe and fittings between the pump and the foot valve (this will be zero for a submersible pump).

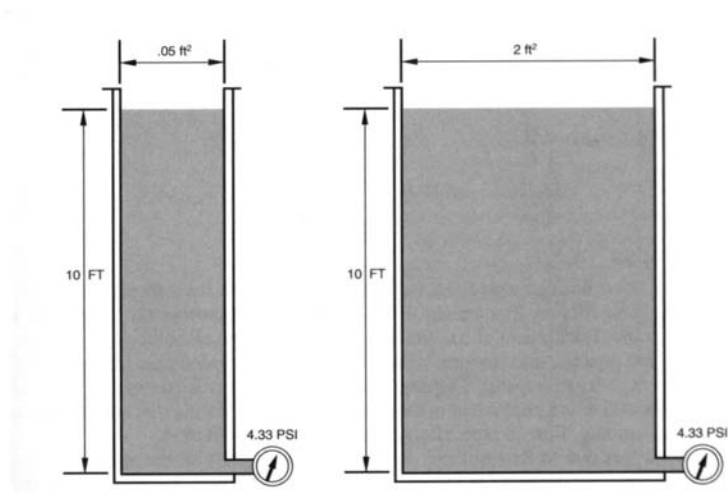

Figure 2-1 Hydraulic head depends only on column height

Friction Head loss is the energy that water loses from friction while it is moving in the system through pipelines and valves. When water moves through a pipe, it must overcome resistance caused by friction from contact with the pipe walls and its own turbulence. The amount of friction loss depends on the flow rate, pipe characteristics such as length, size and type of pipe, and on the number and type of pipe fittings.

Head loss can be significant if the pipe surface is roughened by corrosion (pitting), tubercles (crusty corrosion build-up), slime growth, or sediment. The amount of pipe roughness is referred to as the C factor. The higher the C factor, the smoother the pipe. Head loss can also be caused by water suddenly changing direction or velocity as a result of valves, bends, and reducers.

Elevation Head is the vertical distance in feet from the pump to the highest point of the water system, plus friction losses in pipe and fittings between pump and point of discharge.

Total Dynamic Head (TDH) is the total amount of energy that a pump has to deliver to move water from one point to another. Dynamic means the water is in motion rather than static. For example: the well pump has to lift water from a 150 ft pumping level and push it 120 ft up to the storage tank. Not factoring friction head loss, the total dynamic head would be 150 ft suction lift + 120 ft discharge head = 270 ft TDH.

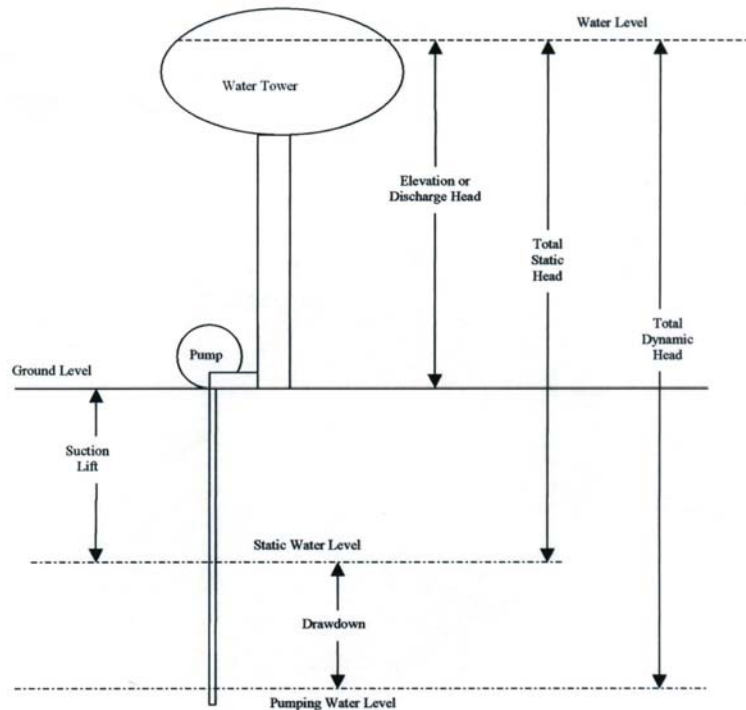

The following pumps are commonly used in water systems:

- **Positive displacement pumps** – used for feeding chemicals because they deliver a constant volume with each stroke.
 - Piston pumps – the RPM of the pump determines the output of flow from the pump.
 - Diaphragm pumps – the amount of chemical fed is determined by either adjusting the length of the stroke or the number of strokes per minute.



It is recommended that your diaphragm pump be equipped with a four function valve. The functions of this valve are:

1. Anti-siphon (automatic): prevents siphoning when pumping downhill or into a vacuum.
2. Backpressure (automatic): supplies approximately 25 psi backpressure to prevent over pumping when little or no system backpressure is present.
3. Pressure relief (automatic): if the discharge line is overpressurized, the valve opens sending the chlorine solution back to your supply tank.
4. Line depressurization (manual): by pulling both knobs, the discharge line will drain back to your supply tank.

The pump should be placed so that it is lower than the chlorine level in the tank so that the pump does not lose its prime. It is recommended to have a back-up pump.

- **Centrifugal pumps** – are widely used in the water industry and consist of a pump casing and an impeller mounted on a rotating shaft. A motor turns the shaft, spinning the impeller. The impeller creates centrifugal force, which throws water into the outer casing or volute. Water is directed into the discharge.

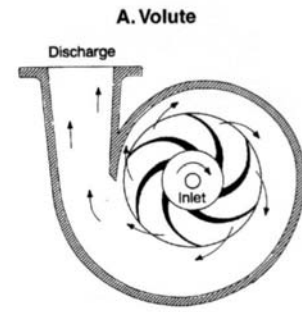

- Vertical turbine pumps – commonly used for well installations and booster pumps. They are capable of producing high capacities at high head.
- Submersible pumps – common for well installations. The entire pump and motor assembly is submersed in water. The motor is mounted below the bowls (impeller housing) so the pump does not have as long a pump shaft as the turbine.
- Centrifugal pumps major parts include:

- Casing – the housing that surrounds the impeller, often called a bowl, for turbine pumps.
- Shaft – the rod the impeller is mounted on and is turned by the motor.
- Impeller – rotating bladed disc that gives force to the water being pumped.
 - o Design can vary (enclosed, open, semi-enclosed).
 - o Design used depends on pumping requirements.
- Wear rings – brass or bronze rings placed on the impeller or casing to control leakage from discharge to suction side.
- Bearings – support and guide the shaft.
- Shaft seals – packing or mechanical seals are used to prevent air from being sucked into the pump along the shaft and to control water leakage along the shaft from the impeller.
- Motor – provides power to turn the impeller.

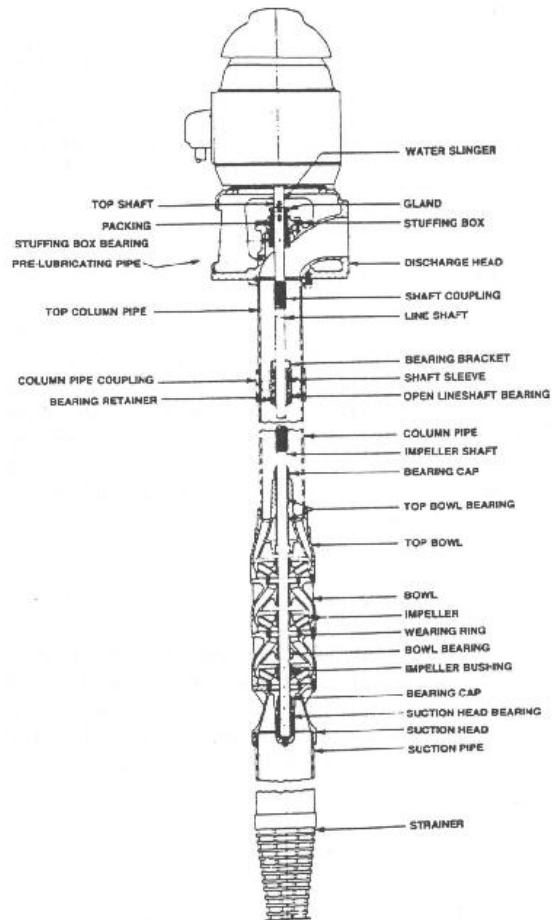

Horsepower and Pump Efficiency

Determining horsepower and pump efficiency is used to select the right pump to supply adequate pumping capacity. The capacity depends on the required flow rate and the total feet of head the pump must work against.

- **Water Horsepower (whp)** – the amount of horsepower required to lift water.

$$\text{Whp} = (\text{Flow Rate, gpm}) (\text{Total Head, ft}) / 3,960$$

- **Brake Horsepower (bhp)** – electrical power required at the pump and motor shaft coupling for any total head; its value changes if total head changes. If a pump is operated for one hour, the kilowatt hours needed can be determined by:

$$1 \text{ Brake Horsepower} = .746 \text{ kilowatt – hour of power}$$

- **Pump efficiency** – can be read from the pump curve (supplied by the pump manufacturer) and is expressed in percent. Neither the pump nor the motor are ever 100% efficient due to friction. Not all the power supplied by the motor to the pump (brake horsepower) is used to lift the water (water horsepower). Not all the electric current driving the motor (motor horsepower) is used to drive the pump. Pumps usually fall between 50-85% efficiency and motors are generally between 80-95% efficient.
- **Pump curve** – a pump curve is a plot of a number of values of discharge quantity versus head. Centrifugal pump discharge head is based on pump type and size. A greater or lesser discharge will require a corresponding greater or lesser horsepower input to the pump.
- Operating a centrifugal pump against a partially closed valve or plugged pipe can cause it to perform less efficiently, thereby wasting electric power. The restriction will:
 - Create head;
 - Reduce the discharge;
 - Require greater energy input; and
 - Reduce operating efficiency.

Higher head = lower flow
 Lower head = higher flow
 Lower flow = lower horsepower
 Higher flow = higher horsepower.

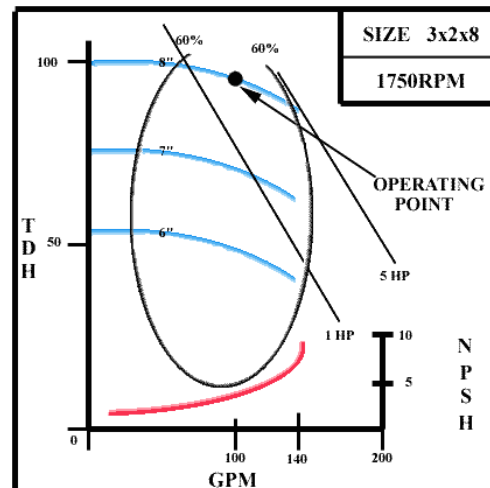

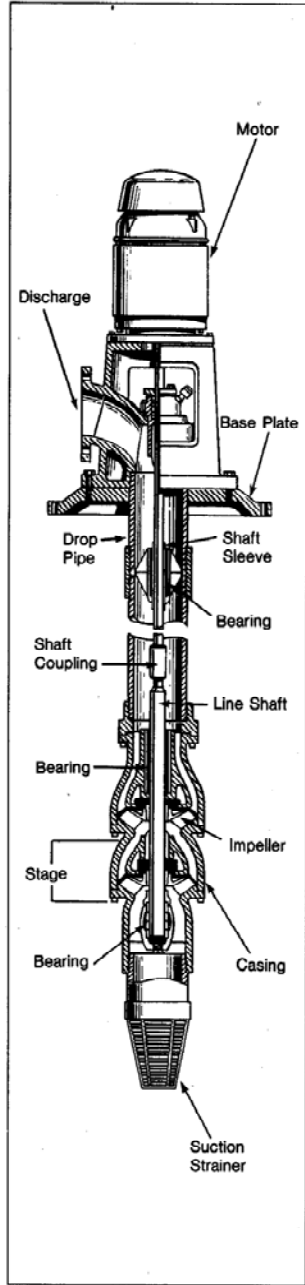

Figure 1-8 Vertical turbine pump.

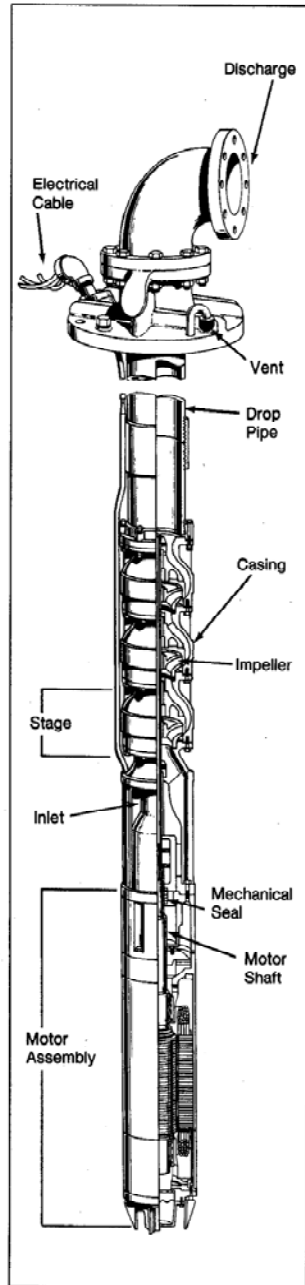

Figure 1-9 Submersible pump.

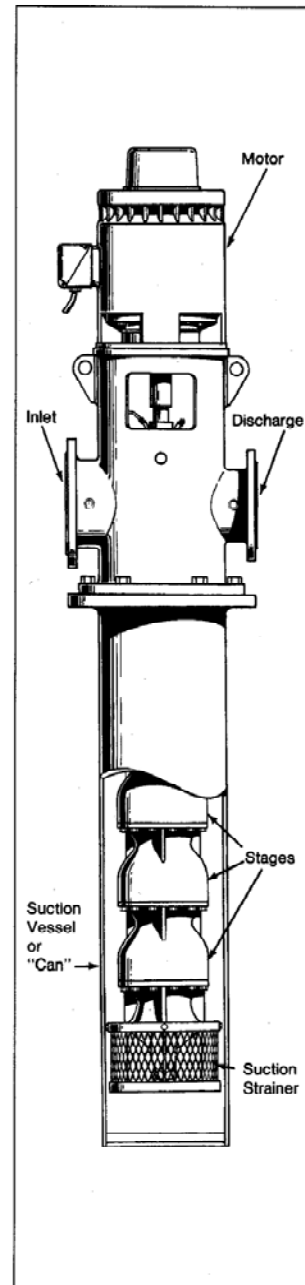

Figure 1-10 Turbine booster pump.

Pump Cavitation

- Pump cavitation is the formation and collapse of gas pockets or bubbles on the blade of an impeller or the gate of a valve.
- Causes the pump or valve to vibrate and sounds like chattering marbles.
- Commonly occurs in pumps when the pressure at the pump inlet drops below the pressure of the water being pumped.

- Cavitation may cause the formation of pits on the impeller and the eventual wearing away of the impeller.
- Caused by allowing intakes to become clogged or by using a pump that discharges more water than it is designed to pump.
- To prevent cavitation:
 - The intake of the pump must remain clear.
 - If pump discharge is excessive, throttle with discharge valve.
 - Coat the impeller and volute with epoxy-metallic materials.

Water Hammer occurs when moving water suddenly stops, such as by closing a valve too fast.

- Water oscillates in the pipe, causing a loud banging or hammering sound.
- Fluctuating pressures can damage piping and connections.

Pump Maintenance

Major areas of maintenance concern:

- Couplings must be properly aligned.
- Inspect and lubricate motor/pump bearings on a regular basis.
 - Reduce friction and wear to moving parts.
 - Prevent corrosion by sealing out dirt and contaminants.
 - Lubricating water should be of a quality equal to or greater than the pumped water.
 - Too much lubrication – high heat can result; too little lubrication – excessive wear can result.
 - Wrong kind of lubricant – may contaminate potable supply or may not provide adequate wear protection.
 - Contamination of lubricant – may result in excessive wear and high heat.
- Seals – mechanical or packing type.
 - Packing type must be allowed to leak a small amount (20 drops/min) for lubrication.
 - Mechanical type does not normally leak water.

Motor maintenance:

- The motor should be properly lubricated.
- Motor should be kept clean, dry, and cool.
- Motor guards/ventilation screens must be in place.

Storage

Storage is used to serve two major purposes:

1. To provide pressure to the system; and
2. To provide storage volume at least equal to the average day demand of consumers.



- All water storage facilities shall have the overflow brought down to an elevation 12-24 inches above a manhole or splash plate, and shall be screened.
- Before putting storage tanks in service, they shall be disinfected at a chlorine concentration of 50 ppm for 24 hours or in accordance with AWWA Standard C652. Water samples taken after the disinfection procedure shall indicate microbiologically safe water.
- Manholes above the waterline shall be framed at least 4 inches above the surface of the roof at the opening. Manholes above the waterline in a ground level structure should be elevated 24-36 inches above the top or the covering sod. The access hatch opening shall be fitted with a solid watertight cover that overlaps the framed opening and extends down around the frame at least 2 inches, is hinged, and has a locking device.
- Vents shall be able to prevent the entrance of rainwater and shall be screened.
- Elevated tanks with riser pipes over 8 inches shall be located in a manner that will prevent the flow of sediment into the distribution system.
- Every catwalk over finished water in a storage structure shall have a solid floor with raised edges so designed that shoe scrapings and dirt will not fall into the water.
- Railings or handholds shall be provided on elevated tanks where persons must transfer from the access tube to the water compartment.

Pressure tanks:

- Only allowed when a public water supply serves fewer than 50 homes.
- The capacity of the well and pumps shall be at least ten times the average daily water use. The volume of the tank shall be at least ten times the capacity of the largest pump in gpm. (Example: a 250-gpm pump requires a 2,500 gallon storage tank.)
- Each pressure tank shall have an access manhole, drain, pressure gauge, water sight glass, automatic or manual blow off means for adding air, and pressure operated start-ups for the pumps.



Electrical Safety

Extreme caution is advised when working around electricity. Potentially lethal voltages exist. **If you are not experienced with electricity, seek professional help.**

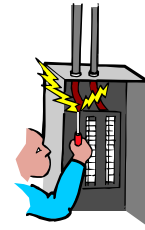

Personal protective equipment to use when working around electricity and water include the following:

- Nonconductive hard hat;
- Safety glasses and face shield; and
- Rubber gloves and rubber soled shoes.



Some common sense safety procedures to follow when working around electricity:

- Inspect electrical equipment and wires before using;
- Shut off the power source before working on equipment or wiring;
- Follow lockout and tagout procedures;
- Read and follow manufacturers' instructions; and
- Obey electrical warning signs.

Lockout/Tagout Procedure

Energy isolation and lockout/tagout procedures are to be applied only by trained employees. All employees in the affected work area must be notified. The procedure must follow the following seven steps:

1. Prepare for shutdown – know the type and amount of energy for the equipment, possible hazards, and how it can be controlled.
2. Equipment shutdown – use operating controls safely to shutdown equipment (*i.e.*, valves).
3. Equipment isolation – disconnect equipment from the power source.
4. Apply lockout/tagout devices – use standardized devices, used by every worker on the crew, by the use of a multiple-lock hasp. If tags are used, attach them in the same location as a lock and fill them out completely.
5. Control of stored energy – guard against energy left in the equipment after the energy source has been disconnected. This may include: relieve pressure, release tension, block or brace parts, bleed lines, drain piping, and purge lines.
6. Equipment isolation verification – clear danger area of personnel and verify energy isolation.
7. When removing lockout/tagout devices, make sure the equipment is safe to operate. Notify all workers that devices are being removed and tags should be signed and turned in.

Leak Detection



Water is commonly lost from the water distribution system in several ways. When investigating unaccounted-for water usage, (the difference between the amount of water pumped into the system, and the amount of water used by the water users) there are many things to consider:

- Check the well house, treatment plant, individual, household, and business meters for accuracy.
- Check for an unusually large amount of water being used by a customer. If the meters are working properly, check for an error in documenting this information such as an incorrect previous reading.

If these items have all been addressed, there may be a water leak. Leaks in a water system are very common. A thorough investigation of the water system and other facilities is the next step. The following are water leak indicators:

- An unusual water puddle or flow where one shouldn't be present.
- An unusual amount of flow into the wastewater treatment facility.
- Increased amount of flow into the storm sewer system.
 - Check outfalls of the storm sewer system for higher than normal flows.
 - If storm sewer outfalls have higher flows, check manholes upstream.
- If the source of the leak can be traced back to a smaller area, such as a block or a few blocks, listening devices can be used to help find the leak.

Leak Detection Devices

Correlators and listening devices are commonly used to locate underground leaks. Both of these devices are dependent on the sound water makes when it leaks underground. The success of finding the water leak can be dependent on the type of pipe material. Metal pipe creates more noise when water is leaking out of a hole or crack in the pipe. PVC pipe does not transmit sound well and is unfavorable in finding a water leak.

To locate a water leak, correlators and listening devices are connected to fire hydrants, gate valves, or curb stops. Listening devices can also be used on the surface of the street to detect the sound of water leaking underground.



Meter Reading

Water meters may be read by remote, by the customer, or by a water system employee going door-to-door. Meter readings help ensure that the customer is paying a fair bill for the amount of water being used. Every operator should understand the important tasks associated with reading water meters.

- Check for signs of tampering or damage to the meter or outside readout.
- Check to see if the outside readout is located properly and visible, not hidden behind shrubs or bushes.
- Check to see that the meter is properly installed.
- Check for evidence that a “jumper” hasn’t been used to steal water.
- Check to see if remodeling has been performed in the building that would require the meter to be relocated or changed to a smaller or larger meter.

Documentation of any observations should be recorded on a meter card in a comments section of the meter reading book or hand-held meter reading device. Report any findings for corrective action.

Safety

Many different safety items have been mentioned earlier in this study guide such as lockout/tagout and chemical safety. Here are a few additional safety items that water operators need to know and understand.

- **Material Safety Data Sheets (MSDS)** – Material Safety Data Sheets (MSDS) must be available to all operators, designated representatives, contractors, visitors, emergency responders, and OSHA (Occupational Safety and Health Administration).
 1. The MSDS document provides a profile of hazardous substances. For example, these sheets describe specific materials compatibility; handling precautions, spill responses, and hazardous properties of the chemicals.
 2. The MSDS document must be posted in a conspicuous location for easy reference.
 3. The MSDS document must provide guidance to operators on what type of personal protective equipment (PPE) should be used to protect against chemical exposure.
 4. The MSDS document provides information about proper storage procedures of hazardous chemicals. Chemical compatibility and containment are of particular importance. *Compatibility* refers to appropriate storage tank, piping, and valve materials to be used with the particular chemical. Chemicals that are not compatible with tanks and pipes may cause corrosion problems, equipment failures, and serious safety hazards. *Containment* is required for chemical storage of large quantities (>500 gallons) of hazardous solutions.



- **Labeling** – all containers holding hazardous chemicals must be *labeled* with appropriate hazard warning labels. Labels must be designed in such a manner as to be clearly understood by all workers. Signal words such as Dangerous, Acid, Corrosive, Caution, or Warning should be clearly visible on all chemical containers.



- **Confined Space Entry** – a *confined space* is one that: 1) is large enough and so configured that a worker can personally enter and perform assigned work; 2) has limited or restricted means for entry or exit (*e.g.*, tanks, vessels, silos, storage bins, hoppers, vaults, and pits); and 3) is not designed for continuous operator occupancy. Moreover, a confined space is one in which ventilation may be insufficient to remove dangerous gases or add fresh air.

Along with the requirement to develop a written confined space program, water operations personnel are required under OSHA’s Confined Space Entry Standard (29 CFR 1910.146) to:

1. Identify and properly label all workplace-confined spaces.
2. Train confined space entrants, attendants, and “competent” persons on all aspects of safe confined space entry. Be sure to document the training.
3. Train and station a qualified rescue team at each entry location whenever required.
4. Ensure that someone qualified and trained in CPR/First Aid is readily available anytime confined space entry is made.
5. Provide approved safety equipment to ensure safe confined space entry (*e.g.*, air monitoring equipment, lighting, harnesses, etc.).



- **Air Monitoring** – the two most important safety concerns when entering a confined space are oxygen deficiency and hazardous gases.

The primary issue associated with confined spaces is oxygen deficiency. If the confined space to be entered is devoid of oxygen, all other hazards are of secondary importance. Normal air contains 20.8% oxygen by volume. OSHA specifies that the minimum safe level is 19.5%. According to OSHA, the maximum safe level is 25%. An atmosphere too rich in oxygen can cause fire and explosion.



Toxic atmospheres within the confined space are also a major concern to the water operator. Because of the behaviors of various toxic gases, all areas (top, middle, and bottom) must be tested with properly calibrated testing instruments to determine what gases are present. In addition to toxicity problems, some gases and vapors are combustible or explosive. OSHA requires atmospheric testing of confined spaces for the presence of such gases or vapors.



Because of the inherent hazards associated with confined space entry, entrants should be equipped with safety equipment designed to protect him/her against the hazards. At a minimum, confined entry personnel must be equipped with emergency rescue equipment such as a full-body harness combined with a lanyard or lifeline to allow for external rescue. It is advisable to set up a hoist system over the confined space (e.g., tripod with winch that can be connected to the person in the confined space). In addition to a rescue harness, the entrant may be required to use an air supply respirator. Additional equipment such as radios for communication, spare oxygen bottles, a first aid kit, or other equipment necessary for safe entry into and rescue from the confined space may be necessary.

- **Machine Guarding** – while machines allow for more efficient, productive work, small drinking water system operators must use them with great caution. Machines enhance worker safety, but only if the machine itself is safe. The basic purpose of machine guarding is to prevent contact with dangerous parts of machines. For example, a pump or motor guard protects operators from rotating parts.
- **Hearing Conservation** – the OSHA Occupational Noise Exposure Standard (29 CFR 1910.95) was implemented to protect workers from noise-induced hearing loss in the workplace. Under this Standard, small drinking water supply systems are required to have a written Hearing Conservation Program. Under this Program all employees exposed to noise exceeding an 8 hour time, weighted average of 85 dBA, need to have hearing protection, training, and annual hearing tests.
- **Fire Safety** – fire can occur in any workplace. A fire may be prevented or stopped by removing any of the three necessary elements (fuel, oxygen, and an ignition source) and by interfering with the chain reaction that occurs during ignition.



To fight the fire, direct the spray at the base of the fire, not at the flames. The object is to suffocate and cool the chain reaction that is causing the fire. Slowly sweep the extinguishing agent at the base of the fire until all flames are extinguished. Even after the flames have subsided, continue to apply the agent to prevent a flare-up or flashback of the fire.

Remember the acronym, **PASS** - **P**ull (the lanyard), **A**im the extinguishing agent, **S**queeze the handle, **S**weep the stream.

Traffic Control



It is important to protect the general public from obstacles created during construction and maintenance of the water system. Protection of the workers at the job site is equally important. Protection on a job site can be in the form of:

- Traffic cones;
- Barricades;
- Signs; and
- Flashing lights.



Traffic control devices used depend upon a number of factors including the location of the job site, vehicle traffic, pedestrian traffic, and the type of work. Devices should:

- Conform to approved safety standards (such as MnDot and OSHA);
- Be set up prior to the start of construction or maintenance operations;
- Be properly maintained during the time of such operations;
- Remain in place as long as needed and removed immediately thereafter;
- Be neatly constructed and cleaned or painted as needed; and
- Be unobstructed by weeds, shrubbery, construction material, or equipment.

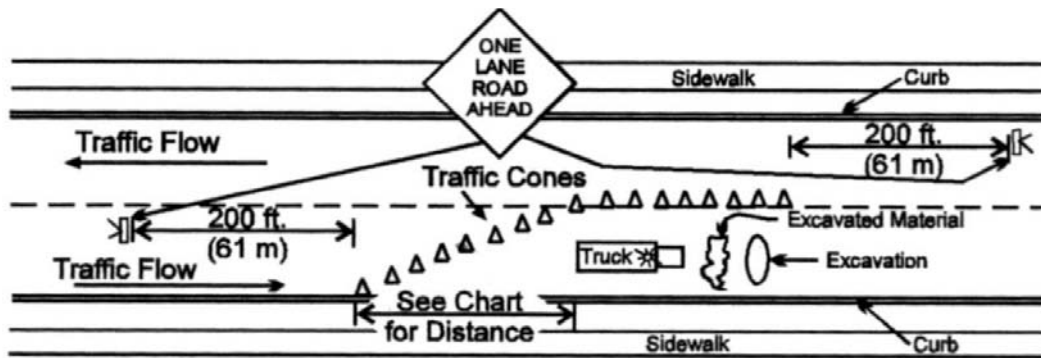

(If traffic is heavy or construction work causes interference in the open lane, one or more flaggers should be used.)

Security

The items listed below may help prevent vandalism and reduce potential safety hazards.

- ✓ Routinely check the facilities for any signs of tampering. Items to check include wells, well houses, plumbing, treatment rooms, storage rooms, and the water facility grounds. It is recommended to check the facilities on a **daily** basis, which will allow you to quickly find any problem that has come up since the last check.



- ✓ Use locks on all well house doors. Provide locking well caps.
- ✓ Prevent access to other water systems components – such as tanks, towers, treatment equipment, and chemical storage – as much as possible. Limit public access to water system components. Deter entry to these areas with signs labeled “Employees Only” or “Restricted Access.” Consult with your local fire department about acceptable ways to lock doors, gates, and windows.

- ✓ Be on the lookout for any suspicious activities or unknown persons around the water system. If a person is unknown, do not hesitate to ask for identification.



- ✓ Provide adequate lighting around the entire facility.
- ✓ If you use water treatment chemicals, make sure that containers purchased or delivered are intact and secure. Use only reliable sources and known contractors. It is a good idea to have a list of contractors and vendors that you may use. Do not accept deliveries from unknown individuals or vendors. It is advisable to have a staff person present during all deliveries.

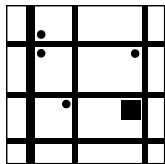

- ✓ If your water supply is run using a computer system, make sure that system is secure and be on the alert for attempts to disrupt its operation. Also, secure all maps, records, and any other information that is vital to the operation of the water system.

- ✓ If you hire someone from a vendor to work on the water system (plumber, well contractor, etc.) verify that any individuals coming to your facility are employed by that vendor before allowing him or her to do any work.



- ✓ Introduce yourself to local law enforcement to review your security measures and to establish a personal contact (name and phone number).

- ✓ Provide an emergency plan for your facility.

Conversions and Equations

1 part per million (ppm) = 1 milligram per liter (mg/L)

Hardness Conversion Factors

1 grain (gr)/gal = 17.1 mg/L

Volume Conversion Factors

1 cubic yard (yd³) = 27 cubic feet (ft³)

1 ft³ = 7.48 gallons (gal)

Length Conversion Factors

1 foot (ft) = 12 inches (in)

1 yard (yd) = 3 ft

1 meter (m) = 3.28 ft

1 mile = 5,280 ft

Weight Conversion Factors

1 ft³ = 62.4 pounds (lb) H₂O

1 gal = 8.34 lb H₂O

Detention Time

Detention Time = $\frac{\text{volume of tank}}{\text{Flow rate to or from tank}}$

Head/psi

Head (feet) = pounds per square inch (psi) x 2.31

psi = Head (feet) x 0.433

Water Loss

Water Loss (%) = $\frac{\text{Gallons pumped} - \text{Gallons sold}}{\text{Gallons pumped}} \times 100\%$

Flowrate

Flowrate: gal/hour (GPH) = GPM x 60 minutes (min)/hr

gal/day (GPD) = GPM x 1,440 min/day

MGD (million gallons/day) = $\frac{\text{gal/day}}{1,000,000}$

Dosage

Dosage (mg/L) = demand (mg/L) + residual (mg/L)

Chemical Feed Rate

Chemical feed rate: 100% pure chemical lbs per day = MGD x 8.34 x ppm

Less than 100% pure chemical lbs (or gal) per day = $\frac{\text{lbs (or gal) pure chemical (*)}}{\text{percent purity}}$

*Insert number from chemical feed rate equation above

Drawdown

Drawdown is the distance between the static groundwater level and the pumping level.

Specific Yield

$$\text{Specific Yield} = \frac{\text{GPM}}{\text{Drawdown}}$$

Horsepower

% pump efficiency (pe), % motor efficiency (me)
 1 Horsepower = .746 kilowatts power, ¢/Kw-Hr

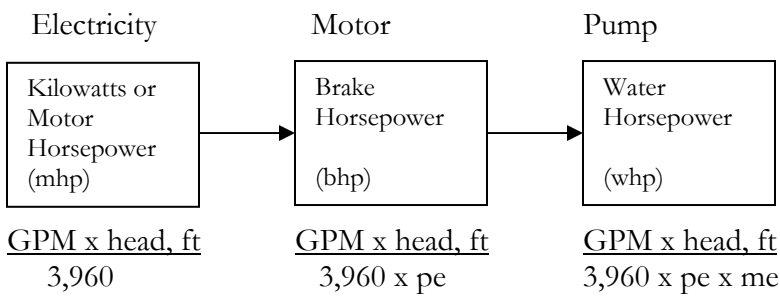

Geometry

$\pi = 3.14$
 $R = D/2$

Rectangle

Perimeter (P) = (2 x Length (L)) + (2 x Width (W))
 Area (A) = L x W

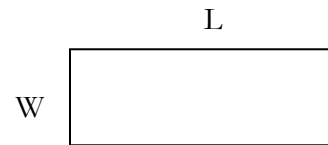

Rectangular Solid

Volume (V) = Height (H) x L x W
 Surface area (S.A.) = 2 x (L x H) + 2 x (H x W) + 2 (L x W)

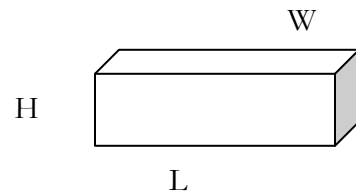

Circle

Circumference (C) = $\pi \times r^2$ (radius squared)

$$A = \pi \times r^2$$

OR

$$A = 0.785 \times d^2$$

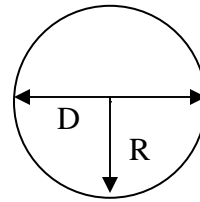

Sphere

$$V = 4/3 \pi r^3$$

$$S.A. = 4 \times \pi \times r^2$$

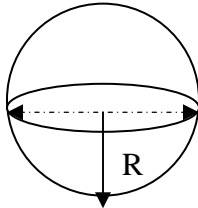

Cylinder

$$V = \pi \times r^2 \times H \quad \text{OR}$$

$$V = 0.785 \times d^2 \text{ (diameter squared)} \times H$$

$$S.A. = (2 \times \pi \times r^2) + (\pi \times d \times H) \quad \text{OR}$$

$$S.A. = (2 \times 0.785 \times d^2) + (\pi \times d \times H)$$

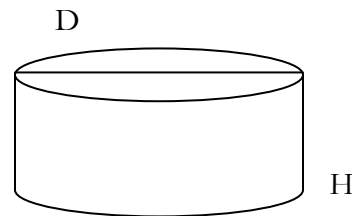

Solving Word Problems

1. *Read the problem.*
2. *Stop and think about what is being asked for.*
3. *Select the proper formula.*
4. *Solve the formula.*
5. *Ask if the answer is reasonable.*

Rounding Numbers

Rounding is the process of taking a number and reducing it to a number with fewer digits. A number is rounded off by dropping one or more numbers from the right, and adding zeroes if necessary to place the decimal point. If the last figure dropped is 5 or more, increase the last retained figure by 1. If the last digit dropped is less than 5, do not increase the last retained figure. Numbers are rounded to reduce the number of digits to the right of the decimal point.

Round to the nearest 1,000 gallons in the following meter reading.

	9	9	6	0
	1000	100	10	

(gallons)

9,960 gallons = 10,000 gallons



Area of a Rectangle

Find the area of a rectangle that has a length of 5 feet and width of 3.6 feet.

$$\begin{aligned} \text{Area} &= \text{Length (L)} \times \text{Width (W)} \\ &= 5 \text{ ft} \times 3.6 \text{ ft} \\ &= 18 \text{ ft}^2 \end{aligned}$$

Area of a Circle

What is the area in square feet of a circular tank that has a diameter of 35 feet?

$$\begin{aligned} \text{Area} &= \pi \times r^2 & \text{OR} & & \text{Area} &= 0.785 \times d^2 \\ &= 3.14 \times 17.5 \text{ ft} \times 17.5 \text{ ft} & & & &= 0.785 \times 35 \text{ ft} \times 35 \text{ ft} \\ &= 961.63 \text{ ft}^2 & & & &= 961.63 \text{ ft}^2 \end{aligned}$$

Surface Area of a Sphere

How many square feet of surface area are in a spherical tank with a diameter of 60 feet?

$$\begin{aligned} \text{S.A.} &= 4 \times \pi \times r^2 \\ &= 4 \times 3.14 \times 30 \text{ ft} \times 30 \text{ ft} \\ &= 11,304 \text{ ft}^2 \end{aligned}$$

Volume of a Rectangle

What is the volume of a tank that is 50 feet long, 30 feet wide, and 12 feet deep?

$$\begin{aligned} \text{Volume in ft}^3 &= L \times W \times H \\ &= 50 \text{ ft} \times 30 \text{ ft} \times 12 \text{ ft} \\ &= 18,000 \text{ ft}^3 \end{aligned}$$

$$\begin{aligned} \text{Volume in gallons} &= L \times W \times H \\ &= 50 \text{ ft} \times 30 \text{ ft} \times 12 \text{ ft} \times 7.48 \text{ gal/ft}^3 \\ &= 134,640 \text{ gallons} \end{aligned}$$

Volume of a Cylinder

Find the volume of a cylinder with a diameter of 10 feet and a depth of 10 feet?

$$\begin{aligned} \text{Volume in ft}^3 &= \pi \times r^2 \times H \\ &= 3.14 \times 5 \text{ ft} \times 5 \text{ ft} \times 10 \text{ ft} \\ &= 785 \text{ ft}^3 \end{aligned}$$

OR

$$\begin{aligned} \text{Volume in ft}^3 &= 0.785 \times d^2 \times H \\ &= 0.785 \times 10 \text{ ft} \times 10 \text{ ft} \times 10 \text{ ft} \\ &= 785 \text{ ft}^3 \end{aligned}$$

$$\begin{aligned} \text{Volume in gallons} &= \pi \times r^2 \times H \\ &= 3.14 \times 5 \text{ ft} \times 5 \text{ ft} \times 10 \text{ ft} \times 7.48 \text{ gal/ft}^3 \\ &= 5,871.8 \text{ gallons} \end{aligned}$$

OR

$$\begin{aligned} \text{Volume in gallons} &= 0.785 \times d^2 \times H \\ &= 0.785 \times 10 \text{ ft} \times 10 \text{ ft} \times 10 \text{ ft} \times 7.48 \text{ gal/ft}^3 \\ &= 5,871.8 \text{ gallons} \end{aligned}$$

Volume of a Sphere

Find the volume in cubic feet of a water tower that is in the shape of a sphere that has a diameter of 30 feet?

$$\begin{aligned} \text{Volume} &= \frac{4}{3} \times \pi \times r^3 \\ &= \left(\frac{4}{3}\right) \times 3.14 \times 15 \text{ ft} \times 15 \text{ ft} \times 15 \text{ ft} \\ &= 14,130 \text{ ft}^3 \end{aligned}$$

Unit Conversions

Conversion of Fractions to Decimals

In order to convert a fraction to a decimal, simply divide the numerator by the denominator.

$$\frac{4 \text{ (numerator)}}{3 \text{ (denominator)}} = 1.33$$

Conversion of Percent (%) to Decimals

To change a percentage to a decimal move the decimal point two places to the left or divide by 100.

$$33\% = 0.33$$

Ratios

This is a comparison of two numbers or units, such as 2 : 1 or 2 parts to one million parts.

$$1 \text{ ppm} = 1 \text{ gallon to } 1 \text{ million gallons}$$

Exponents

Indicates how many times a number is to be multiplied by itself.

$$2^3 = 2 \times 2 \times 2, \text{ where } 3 \text{ is the exponent}$$

$$4^2 = 4 \times 4, \text{ where } 2 \text{ is the exponent}$$

Cancel Units of Measure

This represents a method of converting from one unit to another, such as cubic feet to gallons. You must always write the units down with each number. Cancel out the same units.

$$\frac{\text{gallons}}{\text{minute}} \times \frac{60 \text{ minutes}}{\text{hour}} = \frac{60 \text{ gallons}}{\text{hour}}$$

Flow

Flow rates can be used to determine chemical dosages, water usage of various sources, system efficiency, and future expansion needs.

What is the flow in million gallons per day (MGD) if the flow is 500 gallons per minute (GPM)?

$$\text{Flow} = \frac{500 \text{ gallons}}{\text{minute}} \times \frac{1,440 \text{ minutes}}{\text{day}} \times \frac{\text{million gallons}}{1,000,000 \text{ gallons}} = 0.72 \text{ MGD}$$

Ion Exchange (Zeolite) Softening

One grain of total hardness equals 17.1 ppm per grain of hardness.

Find the grains per gallon of water that contains 230 ppm of total hardness.

$$\begin{aligned} \text{Grains/gallon} &= (230 \text{ ppm}) / (17.1 \text{ ppm/1g/g}) \\ &= 13.45 \text{ g/g} \end{aligned}$$

Find the parts per million of total hardness that contains 12 g/g.

$$\begin{aligned} \text{PPM} &= (12 \text{ g/g}) \times 17.1 \text{ ppm/1g/g} \\ &= 205.2 \text{ ppm} \end{aligned}$$

Detention Time

Detention time is the length of time water is retained in a tank or piping system, or the period from the time the water enters a tank until it flows out the other end.

Find the detention time of a tank that measures 50 feet long, 30 feet wide, and 10 feet deep with a flow to the tank of 1,500 GPM.

$$\begin{aligned} \text{Detention time} &= \frac{\text{Volume}}{\text{Flow}} \\ &= \frac{50 \text{ ft} \times 30 \text{ ft} \times 10 \text{ ft} \times 7.48 \text{ gal/ft}^3}{1,500 \text{ GPM}} \\ &= 74.8 \text{ minutes} \end{aligned}$$

The well is shut down for repairs. You have 50,000 gallons of water in the tower. The system uses 25 GPM. How many hours before you run out of water?

$$\text{Detention time} = \frac{\text{Volume}}{\text{Flow}}$$

$$\begin{aligned} \text{Step 1 (convert gpm to gph)} &= \frac{25 \text{ gallons}}{\text{minute}} \times \frac{60 \text{ minutes}}{\text{hour}} \\ &= 1,500 \text{ gph} \end{aligned}$$

$$\begin{aligned} \text{Step 2 (insert gph)} &= \frac{50,000 \text{ gallons}}{1,500 \text{ gph}} \\ &= 33.3 \text{ hours} \end{aligned}$$

Chemical Feed

The calculation tells the operator the number of pounds of chemical being added to the water per day.

How many pounds of 100% chlorine must be added to 150 GPM to obtain a 1.8 mg/L chlorine feed rate?

$$\# \text{ Chlorine per day} = \text{MGD} \times 8.34 \text{ lbs/gal} \times \text{ppm}$$

$$\text{Step 1 (convert gpm to MGD)} = \frac{150 \text{ GPM} \times 1,440 \text{ min/day}}{1,000,000}$$

$$= 0.216 \text{ MGD}$$

$$\text{Step 2 (insert MGD into equation)} = .216 \text{ MGD} \times 8.34 \text{ lbs/gal} \times 1.8 \text{ mg/L}$$

$$= 3.24 \text{ lbs}$$

If granular calcium hypochlorite (65% available chlorine) is to be used, how many pounds/day will be required using the dose from the question above?

$$\# \text{ calcium hypochlorite} = \frac{\text{MGD} \times 8.34 \text{ lbs/gal} \times \text{ppm}}{\text{percent purity}}$$

$$\text{Step 1 (convert gpm to mgd)} = \frac{150 \text{ GPM} \times 1,440 \text{ min/day}}{1,000,000}$$

$$= 0.216 \text{ MGD}$$

$$\text{Step 2 (insert mgd into equation)} = \frac{.216 \text{ MGD} \times 8.34 \text{ lbs/gal} \times 1.8 \text{ mg/L}}{.65}$$

$$= 4.99 \text{ lbs/day}$$

If liquid sodium hypochlorite (12% available chlorine) is to be used, how many gal/day will be required using the dose from the question above?

$$\# \text{ HTH} = \frac{\text{MGD} \times 8.34 \text{ lbs/gal} \times \text{ppm}}{\text{percent purity}}$$

$$\text{Step 1 (convert gpm to MGD)} = \frac{150 \text{ GPM} \times 1,440 \text{ min/day}}{1,000,000}$$

$$= 0.216 \text{ MGD}$$

$$\text{Step 2 (insert MGD into equation)} = \frac{.216 \text{ MGD} \times 8.34 \text{ lbs/gal} \times 1.8 \text{ mg/L}}{.12 \times 8.34 \text{ lbs/gal} (*)}$$

$$= 3.24 \text{ gal/day}$$

*Dividing by 8.34 lbs/gal converts chemical feed rate from pounds (lbs) to gallons (gal).

Pressure

Pressure is caused by the weight of water above a given point in the system expressed as pounds per square inch (psi), but it can be expressed as feet of head.

Find the pressure on a gauge when the water level is 76 feet above the gauge.

$$\begin{aligned}\text{Psi} &= 76 \text{ feet} \times 0.434 \text{ psi/foot} \\ &= 32.98 \text{ psi}\end{aligned}$$

Find the feet of head when a pressure gauge reads 24 psi.

$$\begin{aligned}\text{Head} &= 24 \text{ psi} \times 2.31 \text{ feet/psi} \\ &= 55.44 \text{ feet}\end{aligned}$$

Water Horsepower

A pump must pump 1,500 gpm against a total head of 30 feet. What water horsepower (whp) is required to do the work?

$$\begin{aligned}\text{Whp} &= \text{gpm} \times \text{head, ft} / 3,960 \\ &= 1,500 \text{ gpm} \times 30 \text{ ft} / 3,960 \\ &= 11.36 \text{ whp}\end{aligned}$$

Drawdown

The static water level in a well is 12 feet. After pumping the water level is 20 feet. What is the drawdown experienced by the well (in feet)?

$$\begin{aligned}\text{Drawdown} &= 20 \text{ feet} - 12 \text{ feet} \\ &= 8 \text{ feet}\end{aligned}$$

Specific Yield

If the well yield is 300 gpm and the drawdown is measured to be 20 feet, what is the specific yield?

$$\begin{aligned}\text{Specific Yield} &= 300 \text{ gpm} / 20 \text{ ft} \\ &= 15 \text{ gpm per ft of drawdown}\end{aligned}$$

Operator Certification Requirements

Who Should Become a Certified Operator?

Anyone who has the direct responsibility for conducting routine, day-to-day, hands-on operational activities for a public water supply.



How Do I Become Certified?

Minimum Requirements to Apply for Certification for Class D and E Operators

- All applicants must have a high school diploma or equivalent; and
- Class D applicants must have at least one year of experience in the operation of a Class A, B, C, or D system.

Application Process

The following three items must be completed to become a certified operator:



- Complete and mail an exam application to the Minnesota Department of Health (MDH) no later than 15 days prior to the exam, along with the \$32 exam fee;
- Pass an exam prepared by MDH. Upon notification of passing the exam, pay the \$23 certificate issuance fee; and
- Upon receiving the issuance fee, MDH will issue the Water Supply System Operator certificate.

Is Training Required?

Yes, training is required for all certified water operators. Continuing education must be completed before your certificate expires. **All certificates are valid for three years.** A Class D operator will need eight hours of training every three years.

Certification Class	Contact Hours
E	4
D	8
C	16
B	24
A	32

Information about water exams and training is available on the internet at www.mrwa.com or www.health.state.mn.us/divs/ch/water/wateroperator/index.htm.

References

- American Water Works Association. Centrifugal Pump Fundamentals. Denver: 1987.
- American Water Works Association. Centrifugal Pumps and Motors: Operation and Maintenance. Denver: 1992.
- American Water Works Association. Water Distribution Operator Training Handbook, Second Edition. Denver: 1999.
- American Water Works Association. Water Treatment. 2nd Edition. Denver: 1995.
- American Water Works Association. Water Transmission and Distribution. 2nd Edition. Denver: 1996.
- California Department of Health Services, Sanitary Engineering Branch and United States Environmental Protection Agency. Water Treatment Plant Operation, Volume I and II. 1983.
- California State University, Sacramento School of Engineering Applied Research and Design Center. Water Distribution System Operation and Maintenance. Sacramento: 1987.
- California State University, Sacramento School of Engineering Applied Research and Design Center. Water Treatment Plant Operation. Volume 2. Sacramento: 1988.
- Commonwealth of Virginia, Virginia Department of Health. Virginia Center for Very Small Waterworks, Class VI Operator's Training Manual. Virginia: 2003.
- Drinking Water Assistance Program – Montana Water Center, and the Montana Department of Environmental Quality, Permitting and Compliance Division. Ground Water Manual for Small Water Systems. Montana: 1999.
- EPA Office of Water.
- Girard Industries. Retrieved July 15, 2004, from the World Wide Web: <http://www.girardind.com>.
- Health Education Services, A Division of Health Research, Inc. Recommended Standards For Water Works. 1997 Edition. Albany: 1997.
- Minnesota Department of Health/Minnesota Rural Water Association. Safe Drinking Water for Your Small Water System: An Operator's Guide. 2002.
- Minnesota Department of Health. Water Works Operators Study Guide. St. Paul: 1996.
- Minnesota Rural Water Association/Minnesota Department of Health. Minnesota Water Works Operations Manual. Elbow Lake: 2001.
- National Rural Water Association. Training Guide: Basic Math Handbook. Duncan.
- Texas A & I University. Natural Gas Distribution, A Self Study Course. Texas: 1988.
- Wisconsin Department of Natural Resources. Small Water System Operator Certification Manual. Madison: 2003.

Notes

Notes