

INDUSTRIAL TRAINING
REPORT - I

WICKRAMANAYAKE HMKSK

E/96/307

NAME : *Wickramanayake HMKSK* *Reg. No. E/96/307*

YEAR : *First*

ORGANIZATION: *Faculty of Engineering,*
University of Peradeniya,
Peradeniya.

PLACE OF TRAINING: *Engineering Workshops (Metal),*
Faculty of Engineering,
University of Peradeniya,
Peradeniya.

DESIGNATION OF SUPERVISOR: *Director, Workshops And Stores*

PERIOD: FROM *14/07/1998* TO *06/10/1998*

DURATION: *12 weeks*

FIELD OF TRAINING: *General*

TABLE OF CONTENTS

TRAINING INFORMATION _____	1
TABLE OF CONTENTS _____	2
ACKNOWLEDGEMENT _____	4
CHAPTER 1: INTRODUCTION _____	5
1.1 SERVICES AND MAJOR FUNCTIONS _____	5
1.2 DIFFERENT SECTIONS AND CLOSE RELATIONSHIPS _____	5
1.3 SITE LAYOUT _____	7
1.4 ORGANIZATIONAL STRUCTURE _____	8
CHAPTER 2: MATERIALS AND CUTTING SPEEDS _____	10
CHAPTER 3: MACHINE TOOLS AND SPECIFICATIONS _____	12
3.1 PLANNING MACHINE _____	12
3.2 UNIVERSAL MILLING MACHINE _____	14
3.3 SHAPER _____	14
3.4 HAND DRILL _____	15
CHAPTER 4: CNC MACHINING CENTER _____	16
4.1 HITACHI SEIKI VA35 CNC MACHINING CENTER _____	16
4.2 MACHINE SPECIFICATIONS _____	18
4.3 G CODE AND M CODE _____	20
4.4 AN EXAMPLE PROGRAM _____	20
4.5 STEPS IN USING THE MACHINE _____	22
CHAPTER 5: FEASIBILITY SURVEY ON A MINI-HYDRO POWER PROJECT _____	24
5.1 INTRODUCTION _____	24
5.2 FLOW PREDICTION AND MEASUREMENT _____	24
5.3 HEAD MEASUREMENT _____	26
CHAPTER 6: MANUFACTURING CROSS FLOW TURBINES _____	28
6.1 INTRODUCTION _____	28

6.2 A CROSS FLOW TURBINE	28
6.3 COUPLINGS	31
6.4 GENERATOR	31
CHAPTER 7: OTHER ACTIVITIES	32
7.1 MANUFACTURING A CHALK MACHINE	32
7.2 SELF POWERED WATER PUMP FOR RIVERS	32
7.3 MILLING A PRINTED CIRCUIT BOARD	33
7.4 AN ELECTRONIC ROTATION COUNTER	34
CHAPTER 8: ANNUAL PHYSICAL VERIFICATION OF STORES	35
CHAPTER 9: ADMINISTRATION, MANAGEMENT AND WELFARE	36
9.1 UNDERSTANDING THE ATTITUDES OF EMPLOYEES	36
9.2 JOB DISPATCHING AND ADMIRING THE WORK	36
9.3 GUIDE LINES FOR BETTERMENT	37
9.4 FREEDOM AND WELFARE SOCIETIES WITH POLITICS	38
CHAPTER 10: PROBLEMS AND DIFFICULTIES ENCOUNTERED	39
CHAPTER 11: CONCLUSION	40
11.1 CONCLUSION	40
11.2 SUGGESTIONS FOR THE IMPROVEMENT OF THE ENGINEERING WORKSHOPS	40
11.3 SUGGESTIONS FOR THE IMPROVEMENT OF TRAINING PROGRAM	40
APPENDIX A: FEASIBILITY REPORT ON THE PROPOSED MINI-HYDRO POWER PROJECT AT KABARAGALA ESTATE	42

ACKNOWLEDGEMENT

It is always a pleasure to remind the fine people in the Engineering Workshops for their sincere guidance I received to uphold my practical as well as theoretical skills in engineering.

Firstly I would like to thank Prof. Sanath Ranathunga (Dean/Engineering and Senior Lecturer/Department of Production Engineering) for convincing me the fact “Whatever a man can imagine, that can be achieved”, treating me as a son of his own and guiding me to taste the real flavor of engineering.

Secondly I would like to thank Dr. S.D. Pathirana (Director/Engineering Workshops and Senior Lecturer/Department of Production Engineering) for the positive attitude he showed for my work, always allowing me to question him and giving prompt replies for my uncertainties in all the fields including educational, social and managerial to labor work. And I always great him for his aspects of crew resource management who always said, “I may be wrong”.

Thirdly I would like to thank Mr. Sarath Perera (Senior Teaching Assistant) and Mr. Mahanama Dharmawardhana (Teaching Assistant) of Department of Production Engineering for extending their friendship towards me and making a pleasure-training environment in the Engineering Workshops. A paper is not enough for me to express the support and guidance I received from them almost for all the work I did there.

Dr. Devapriya Dewasurendra (Head and Senior Lecturer/Department of Production Engineering) is always reminded for allowing me to work in the machine tools in the Department. Mr. A. Illamurugan (Senior Teaching Assistant), Miss F. Faslina Badurdeen (Lecturer) and all the instructors of the Department of Production Engineering are greeted as well fir various supports they extended.

The Workshop Engineer Mr. M.M.K. Sirisena, Workshop Superintendents and all other workmen are also greeted. I thank all the NAITA trainees who underwent training with me for the mutual support I received from them.

Mr. S.B. Wijekoon (Senior Lecturer) and Mr. W.M.R.U. Wickramasinghe (Senior Teaching Assistant) of the Industrial Training Unit of the Faculty are very much thanked for allowing me to have my training in Engineering Workshops.

Finally I apologize all other unnamed who helped me in various ways to have a good training.

Knowledge is power and unity is strength.

CHAPTER 1: INTRODUCTION

Being a public property, the Engineering Workshops is a section of the Faculty of Engineering, University of Peradeniya. In collaboration with the other departments, its prime purpose is to provide facilities for the engineering undergraduates to perform the academic activities of the Faculty of Engineering. During the time of training, it comprised a resource crew of fifty one members directed by Dr. S.D. Pathirana, a senior lecturer of the Department of Production Engineering.

1.1 SERVICES AND MAJOR FUNCTIONS

The infrastructure of the Engineering Workshops could provide the following listed services to its consumers both in academic and non-academic terms.

- Machining of metals
- Welding
- Foundry work
- Smith and fitting work
- Woodwork
- Vehicle repair

Subject to the rules established by the Faculty and the University, deploying the following functions was expected from it.

- Provide above mentioned services to the engineering undergraduates to carry out their academic activities such as practicals, experiments and etc.
- Provide above mentioned services to the Faculty of Engineering and the University as a whole if requested.
- Within the feasibility limits, provide above mentioned services to the public. (Service cost is usually expected to be charged from the service consumers).

It is important to distinctly note that the Engineering Workshops could provide related knowledge wise services to other engineering organizations and to the public who need assistance in their work.

1.2 DIFFERENT SECTIONS AND CLOSE RELATIONSHIPS

The Engineering Workshops itself is a collection of five different subsections that are interrelated. Brief descriptions about them are given below.

1.2.1 DIFFERENT SECTIONS

1.2.1.1 Metal Workshop

The Metal Workshop is the place for machining metals. It comprises the following prominent machine tools with other supporting machines and equipments.

- Drilling machines
- Engraving machines
- Gear shapers
- Grinding machines
- Lathe machines
- Milling machines
- Planers
- Shaping machines
- Slotting machines

* Several varieties of some of these machine tools could be found for specialized operations.

1.2.1.2 Welding And Foundry Shop

The Welding and Foundry shop comprised equipment to deploy following services:

- Arc welding
- Metal casting
- Mig welding
- Oxyacetylene welding
- Spot welding
- Tig welding

1.2.1.3 Smithy And Fitting Shop

The Smithy And Fitting Shop mostly comprised hand tools (anvils, hammers, chisels, etc.) and some machine tools (Electric hammer and sheet metal rollers, benders and cutters).

1.2.1.4 Woodwork Shop

Comprised of 10 carpenters and 2 laborers the Woodwork Shop enclosed the following machine tools.

- Band saw
- Circular saw
- Disc and bobbin sander
- Double end tenoner
- Drill
- Mortiser
- Pattern miller
- Router
- Saw and planner
- Thickness planner
- Wood planer
- Wood turning lathe

1.2.1.5 Vehicle Repair Unit

The Vehicle Repair Unit extends its services to the whole University. It comprised the following work force:

- Electricians (1)
- Greasers (3)
- Mechanics (3)
- Welders (1)

1.2.1.6 Other Sections

The Tool Store and the Consumable Good Store being separate from the above supply the tools and consumable goods to all the above five subsections.

1.2.2 CLOSE RELATIONSHIPS

The Engineering Workshops has close relationships with the other departments of the Faculty and especially with the Department of Production Engineering through which the academic activities are conducted. On the other hand, machine tools and equipments of the Department of Production Engineering are also used to carry out the tasks of the Engineering Workshops freely. Specially, the Computer Numeric Controlled (CNC) Machining Center.

1.3 SITE LAYOUT

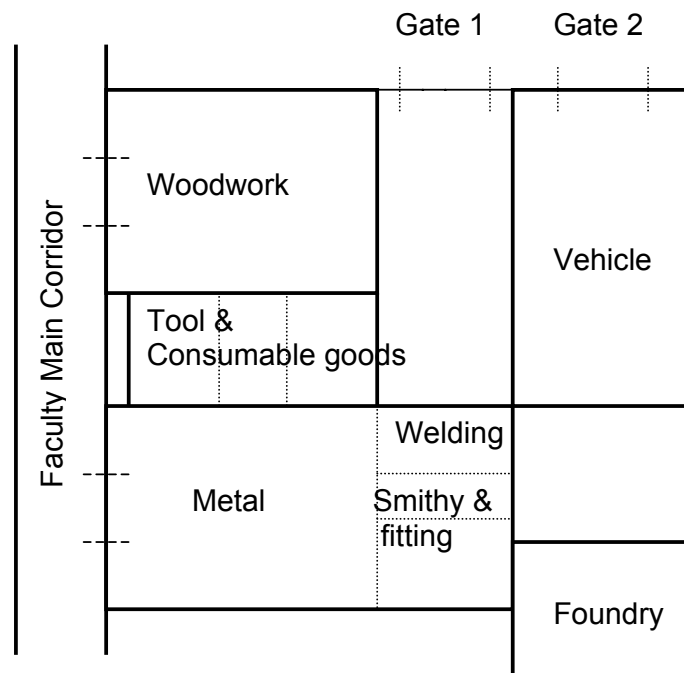

Figure 1-1 The Engineering Workshops

1.4 ORGANIZATIONAL STRUCTURE

Chart 1-1 shows the hierarchical structure of the University of Peradeniya pointing the position of the Engineering Workshops in it.

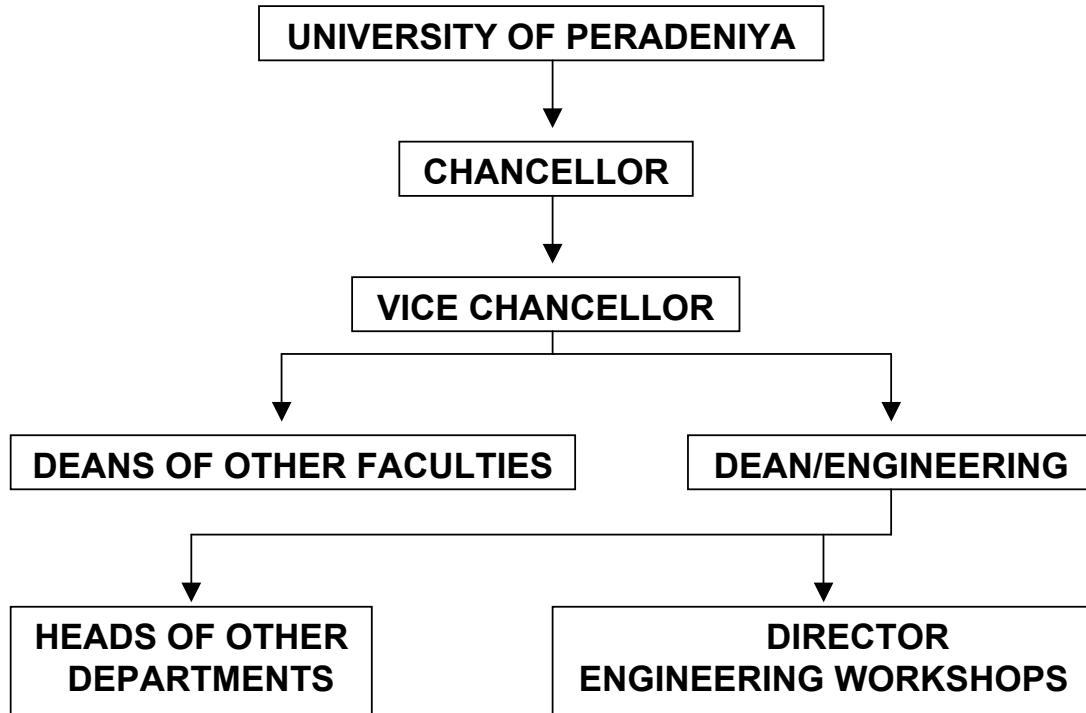
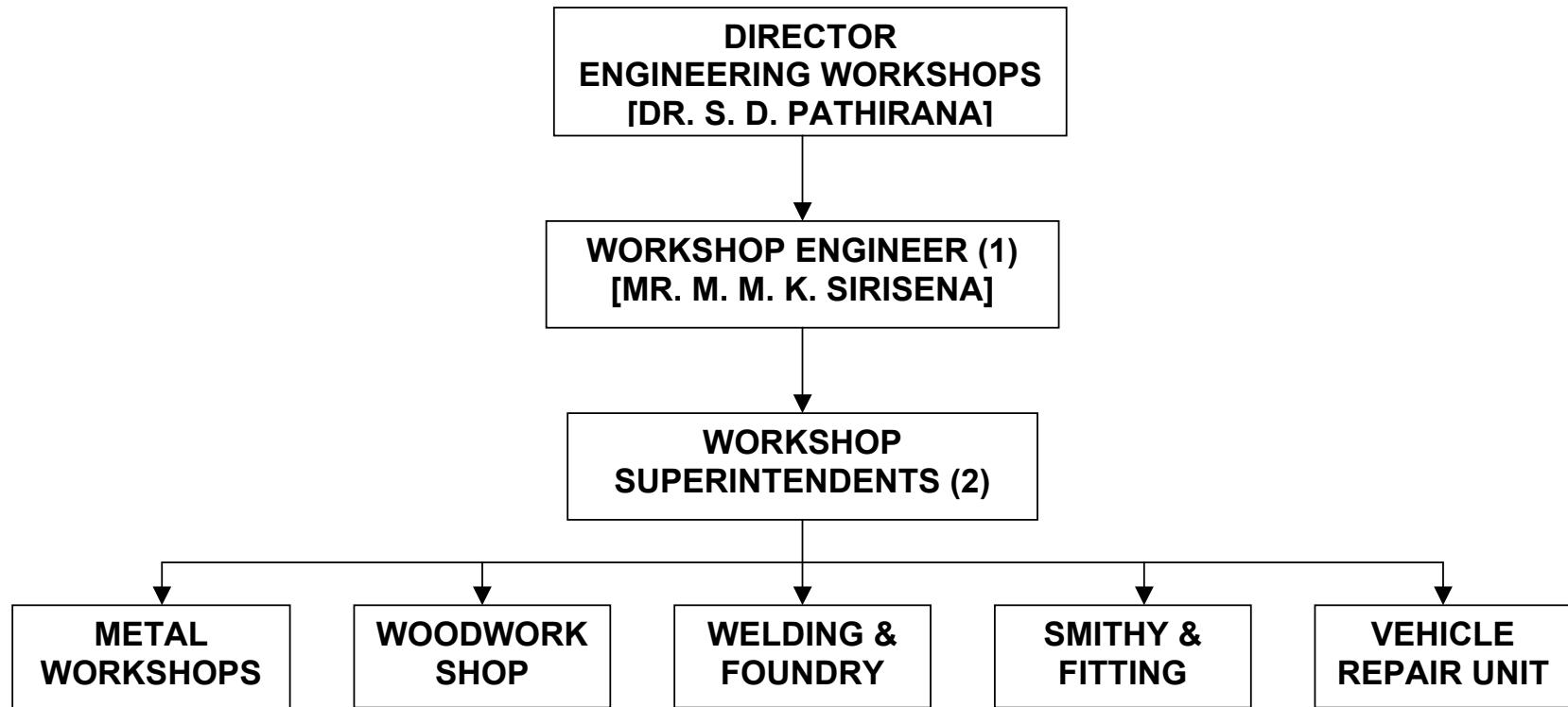

Chart 1-1 Organizational Structure Of The University Of Peradeniya

Chart 1-2 shows the internal organizational structure of the Engineering Workshops.



(48 Workmen: Technicians, Clerks, Mechanics, Carpenters, Welders, Foundry men, Electricians, Machinists and Laborers)

Chart 1-2 Internal Organizational Structure Of The Engineering Workshops

CHAPTER 2: MATERIALS AND CUTTING SPEEDS

Production of an item with desired qualities inherently involves the knowledge of the materials that should be used for the product and the qualities of them. A simple example is using stainless steel for a product that should not get stained.

Furthermore the effective processing of these materials until a finished product is obtained requires the knowledge of processing characteristics of the materials. For example consider machining stainless steel. Some important points to be considered are:

- The tool material that should be used.
- The level of machining (i.e. rough or finish)
- The cutting speed
- Requirement of coolants

Table 2-1 gives the cutting speeds of the commonly used materials under different conditions.

Table 2-1 Cutting Speeds

Workpiece Material		Cast iron	Mild Steel	Malleable iron	Cast iron	Bronze	Aluminium	Stainless steel	Brass
HSS tools	Rough cut (ft/min)	50-60	40-50	80-110	45-60	110-150	400	100-120	200-300
	Finish cut (ft/min)	80-110	65-90	110-130	70-90	150-180	700	100-120	200-300
Carbide tools	Rough cut (ft/min)	120-200	140-160	250-300	150-180	600	800	140-200	600-1000
	Finish cut (ft/min)	350-400	250-300	300-400	200-250	1000	1000	240-360	600-1000

CHAPTER 3: MACHINE TOOLS AND SPECIFICATIONS

3.1 PLANNING MACHINE

Unlike most of other machines, the planning machine contains a sliding table which carries the workpiece. Cutting tools do not move but the workpiece. The one in Metal Workshop was not frequently used because of the heavy operating cost. It was only used for heavy duty metal works.

The prime mover of the sliding table is a DC motor with the following specifications.

- Volts 115/39
- Amps 25/113
- HP 15/4.5
- rpm 1500/720/225
- Excitation Volts 110
- Rating Cont
- Insulation Class E
- Year 1965
- BSS 261 315 7

The DC supply for the above motor is obtained from a DC generator which is directly coupled to an induction motor driven by main AC supply of the Metal Workshop. The rating of those are as follows:

DC Generator Specifications:

- Volts 115/39
- Current 113 A

- Power 13 kW
- rpm 1440
- Excitation 110 V
- Winding Comp. Int.
- Rating Cont
- Insulation Class E
- Year 1965
- BSS 2613/57

Induction Motor Specifications:

- Volts 400/440 (3 Phase 50Hz)
- Current 27.5 A
- Power 21 HP
- Rpm 1440
- Rating Cont
- Stator Delta
- Insulation Class E
- Year 1965
- BSS 2613/57

This arrangement allows quick return motion. Further more this allows feed rate change without any gear arrangement or control of speed of motor. This is done by varying the eccentricity e . The higher the e , the higher the feed rate is. A simple trade off of this feed rate control system is that as the feed rate is reduced, the stroke of the ram also gets reduced. The hydraulic type shaper does not have this problem and the feed rate and the stroke can be independently controlled. Figure 3-2 shows the hydraulic arrangement. This machine has been manufactured by Rockford Machine Tool, Rockford, Illinois, USA.

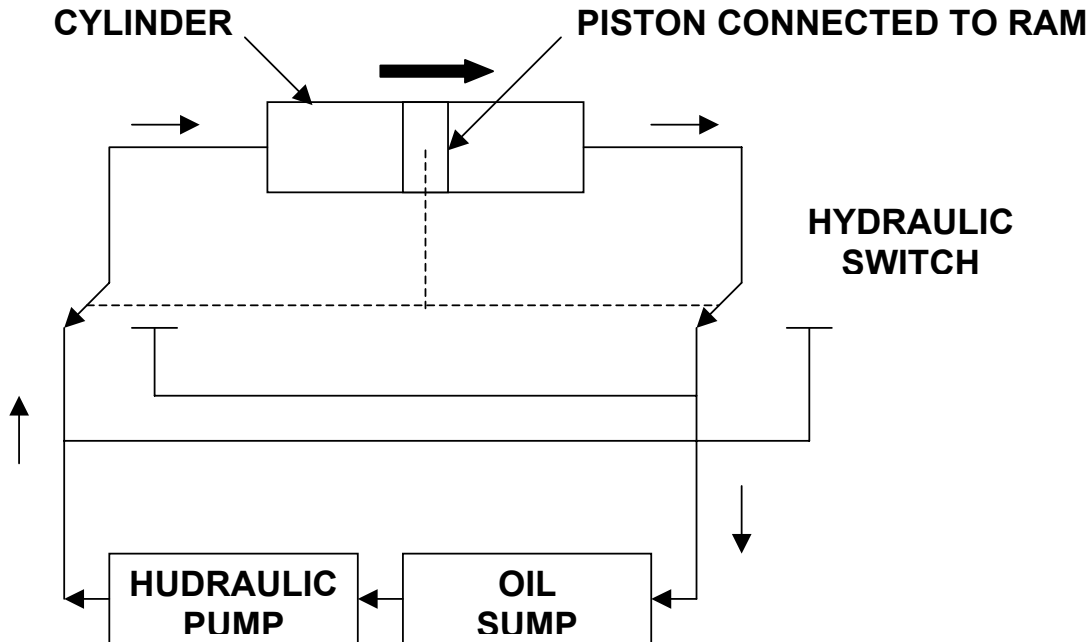

Figure 3-2 Hydraulic Arrangement Of The Shaper

3.4 HAND DRILL

A hand drill is a versatile equipment which can be freely used for drilling holes as well as for some other purposes where a portable rotational prime mover is required.

The specifications of the NHP1030 hand drill manufactured by Makita Corporation, Japan are given below.

- Supply 230 VAC, 2.0 A,
 50-60 Hz
- Power 430 W
- Speed 0-2700 rpm
- Maximum drill bit size 10 mm

CHAPTER 4: CNC MACHINING CENTER

4.1 HITACHI SEIKI VA35 CNC MACHINING CENTER

The Hitachi Seiki VA35 CNC (Computer Numeric Controlled) machining center that belongs to the Department of Production Engineering is frequently used for accurate and automated machining of metals as well as for wood, plastic and other materials. The machining accuracy of the machine is 0.001mm. Figure 4-2 shows various parts of the machine tool.

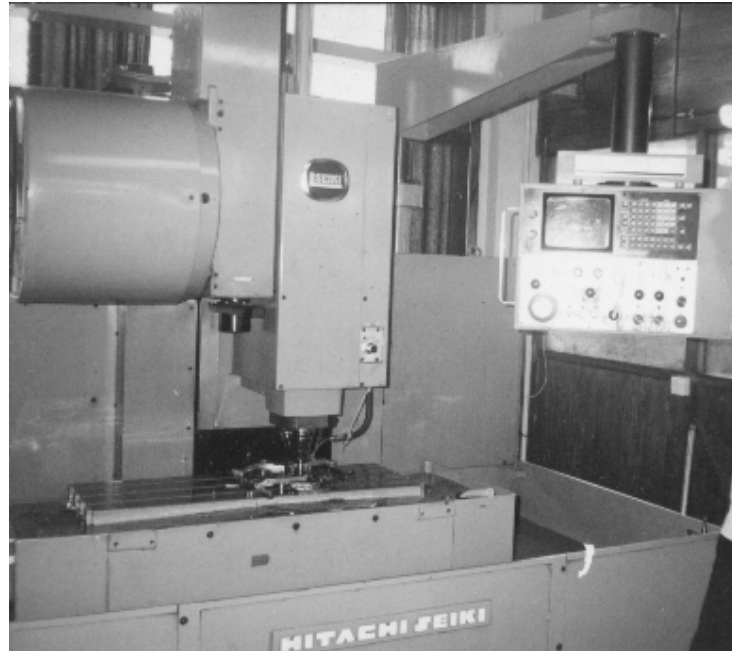

Figure 4-1 Hitachi Seiki VA35 CNC Machining Center

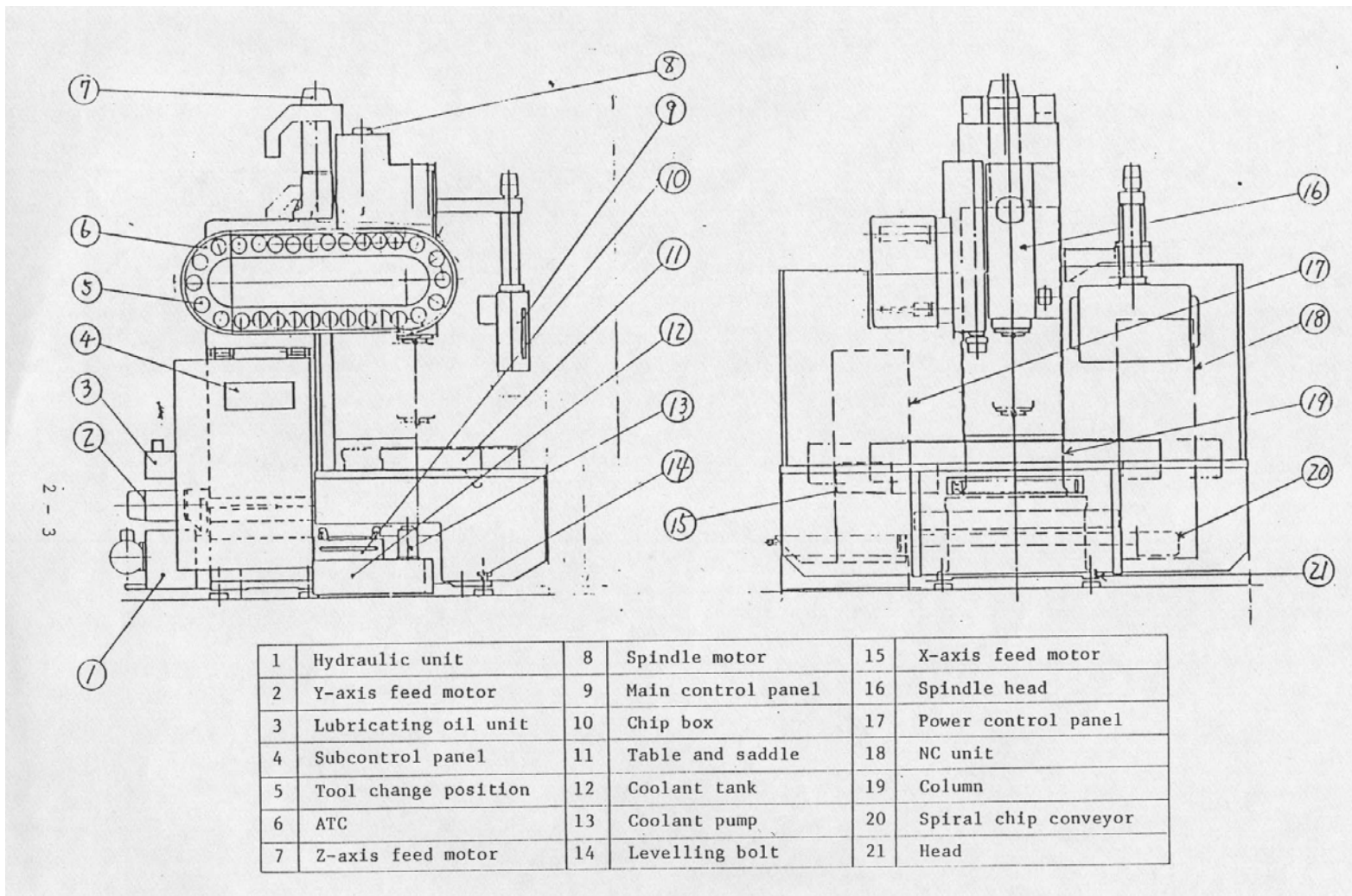

Figure 4-2 Hitachi Seiki VA35 CNC Machining Center

Manufactured by Hitachi Seiki Co. Ltd., Japan, the control unit of this numerically controlled milling machine is of Fanuc System 6M-B. The controlling is based on two Intel 8085 microprocessors.

Figure 4-3 is a block diagram which shows the controlling structure of the CNC machine.

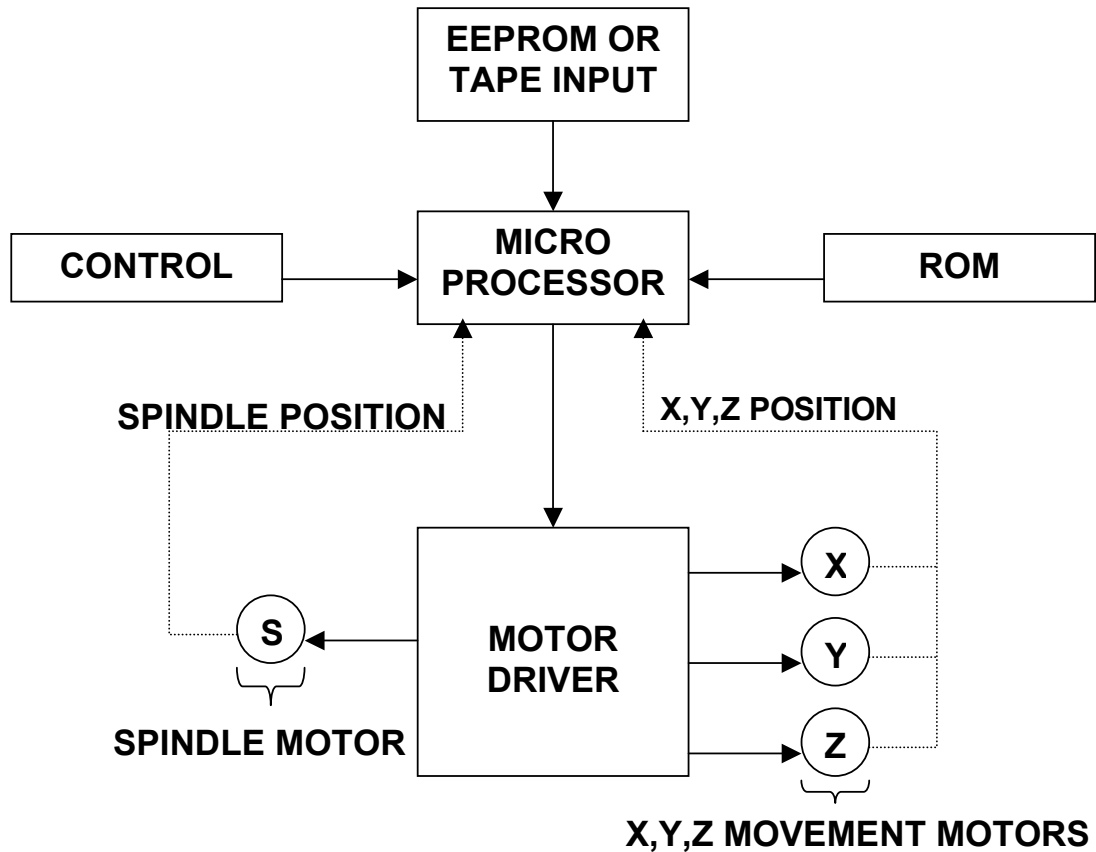

Figure 4-3 Numerical Control Of The Machine

4.2 MACHINE SPECIFICATIONS

4.2.1 GENERAL INFORMATION

- Manufacturer Hitachi Seiki Co. Ltd., Japan
- Model VA 35-II
- Control unit Fanuc System 6M-B
- Weight 4000 kg

4.2.2 TABLE

- Working area 1000*355 mm²
- Maximum carrying capacity 500 Kg

4.2.3 STROKES

- x-axis stroke in the crosswise direction of the table 560 mm
- y-axis stroke in the longitudinal direction of the table 350 mm
- z-axis stroke in the vertical direction of the spindle head 400 mm
- Distance between the spindle nose and top of the table 150-550 mm

4.2.4 SPINDLE HEAD

- Spindle nose contour NT 40
- Spindle speed 60-600 rpm
- Spindle speed change Stepless (s 4 digit)
- Spindle motor AC 5.5 kW (30 min)

4.2.5 FEED

- Least increment 0.001 mm
- Cutting feed rate 3600 mm/min
- Rapid traverse 13000 mm/min

4.2.6 AUTOMATIC TOOL CHANGE (ATC)

- No. of tools 30
- Shank type BT 40, CAT 40
- Maximum tool diameter 95 mm
- Maximum tool length 250 mm
- Maximum tool weight 10 kg
- Tool selection method Random shortest course
- Pull stud type MAS - 1

4.3 G CODE AND M CODE

The entire functioning of the machine is based on G Code and M Code specifications.

G Codes define the preparatory functions of the machine. In simple terms, they control the movement and machining related functions of the machine tool. For example, the code "G76" followed by some related arguments is used for fine boring. "G00" with X,Y,Z arguments rapidly moves the bed and the spindle head to the position specified by the arguments.

M Codes are known as auxiliary functions. They control specific behaviors of the machine. For example "M08" turns on the coolant, M05 stops the spindle.

4.4 AN EXAMPLE PROGRAM

The listing given below is a program which was used to bore holes in couplings of two turbines which were manufactured in the Engineering Workshops. It is written in G and M Codes.

Unless otherwise stated, all the dimensions are in mm.

- 1 G28 G91 Z0;
- 2 G28 X0 Y0;
- 3 G40 G49;
- 4 G90;
- 5 G92 X253.087 Y177.818 Z343.05;

```

6  G00 X131.25;
7  G00 Z5.0 F10;
8  M03 S150;
9  M98 P151;
10 M05;
11 M09;
12 G28 G91 Z0;
13 G28 X0 Y0;
14 M30;
15 %

```

The meaning of each line is given below.

- 1 Return to reference point, Incremental programming, Z=0 is the reference point (Z movement only)
- 2 Return to reference point, X=0 and Y=0 (X and Y movements only)
- 3 Tool diameter compensation cancel, Tool length offset cancel
- 4 Absolute programming
- 5 Programming of absolute zero point, X=253.087, Y=177.818, Z=343.05
- 6 Positioning (rapid), X=131.25, Y=0
- 7 Positioning (rapid), Z=5.0, Feed rate set to 10 mm/min
- 8 Spindle rotation CW, speed=150 rpm
- 9 Sub program (o0151) call-out
- 10 Spindle stop
- 11 Mist/coolant off
- 12 Return to reference point, Z=0, Incremental programming (Z movement only)
- 13 Return to reference point, X=0 and Y=0
- 14 End of program, Control unit reset
- 15 Just display the end of current listing

Line 9 in the above program calls the sub program o0151. This sub program is the actual part of the program which bore holes and is listed below.

- 1 G76 G98 X131.25 Y0.0 Z-52.0 Q0.5 R2.0;
- 2 X119.903 Y53.384;
- 3 (some more x and y values)
- 4 M99;

The meaning of each line is as follows:

- 1 Fine boring; Return to initial level in canned cycle after finishing; Starting X,Y coordinate: X=131.25, Y=0.0; Final Z coordinate = -52.0; Before boring tool is taken out, move it 0.5 away from the bored wall of the workpiece; Radius of boring = 2.0 (This value does not have any effect on boring since the tool determines the actual radius.).
- 2 Repeat boring for X=119.903 and Y=53.384.
- 3 Repeat the same in line 2.
- 4 End of sub program.

4.5 STEPS IN USING THE MACHINE

The distinct operations involved in using the CNC machine are listed below in sequence they are done.

1. Generating the program (in G & M Codes)
2. Sending it to the machine
3. Running the program

First a drawing of the machined workpiece is created using AutoCAD in a PC. Then using a special routine of AutoCAD, the contours of the cutting tool are generated. This is finally stored as a text file in the hard drive of the PC.

Next, the CNC machine is set to retrieve this file. Through the coaxial cable which links the PC and CNC machine, it is then fed into the machine tool. A numeric name for the program is given at the beginning of the file retrieval to figure out the starting point (or the address in the memory) of the retrieving program from earlier read programs.

Using this numeric name of the program, it is taken to the front from other programs in the memory and it stays waiting to run. Pressing the "Start" button sequentially executes the listing.

Figure 4-4 shows the monitor (on the Main Control Panel) displaying a program waiting to be executed.

If needed a program can directly be written using the Main Control Panel of the CNC machine and executed. This is tedious and errors may occur easily.

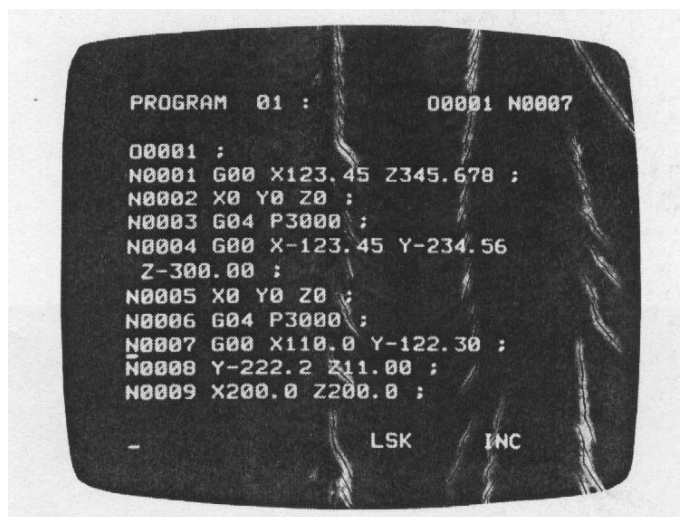

Figure 4-4 A Program Waiting To Be Executed (Sub Control Panel Display)

CHAPTER 5: FEASIBILITY SURVEY ON A MINI-HYDRO POWER PROJECT

5.1 INTRODUCTION

This chapter described the methods that were used for flow rate prediction and measurement and head measurement of a stream called Madapiti Oya in Nuwara Eliya district as a feasibility survey to construct a mini-hydropower plant. APPENDIX A: FEASIBILITY REPORT ON THE PROPOSED MINI-HYDRO POWER PROJECT AT KABARAGALA ESTATE contains full details of it.

The capacity of a hydropower scheme entirely depends on two factors being the water flow rate and the head (the height difference between the reservoir and the power house).

5.2 FLOW PREDICTION AND MEASUREMENT

Two methods that were carried around the stream are described here. One is a flow prediction method and the other one is a flow measurement method.

5.2.1 AREA-RAIN FALL METHOD

This is a flow prediction method. In simple terms, the catchment area of a water stream is multiplied by the rainfall to find the flow.

Figure 5-1 shows an example contour map that can be used in this method to find the catchment area of a stream. The lighter dashed lines enclose the areas. For example the area which determines the flow at point B of the stream is enclosed by the outer light dashed lines bounded by three mountain peaks.

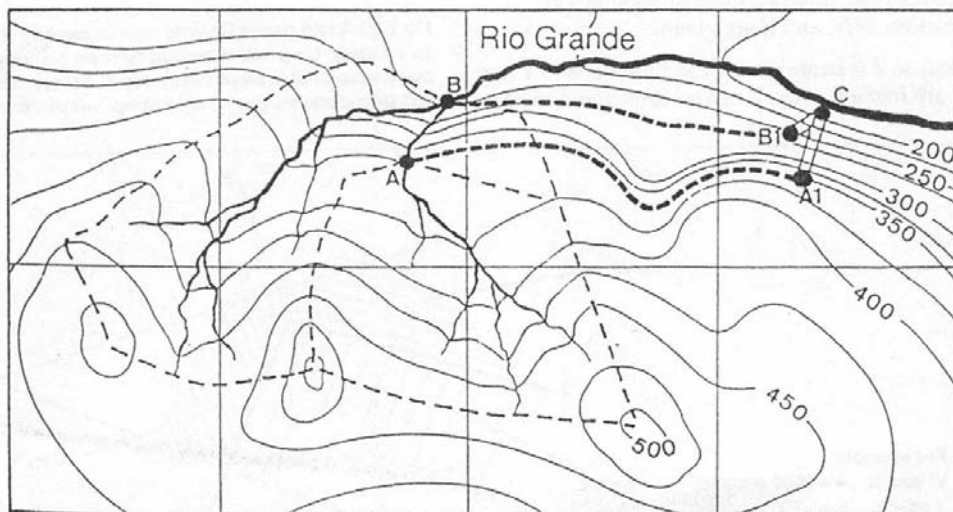

Figure 5-1 Using A Contour Map To Find The Catchment Of A Stream

Figure 5-2 shows a simple representation of a hydrological cycle. It is seen that sub-surface transfer flow, evaporation and transpiration reduce some amount of water from the value

calculated just by multiplying the area and the rainfall. Depending on the weather and geographical conditions, suitable corrections for these can be applied for a more accurate flow prediction.

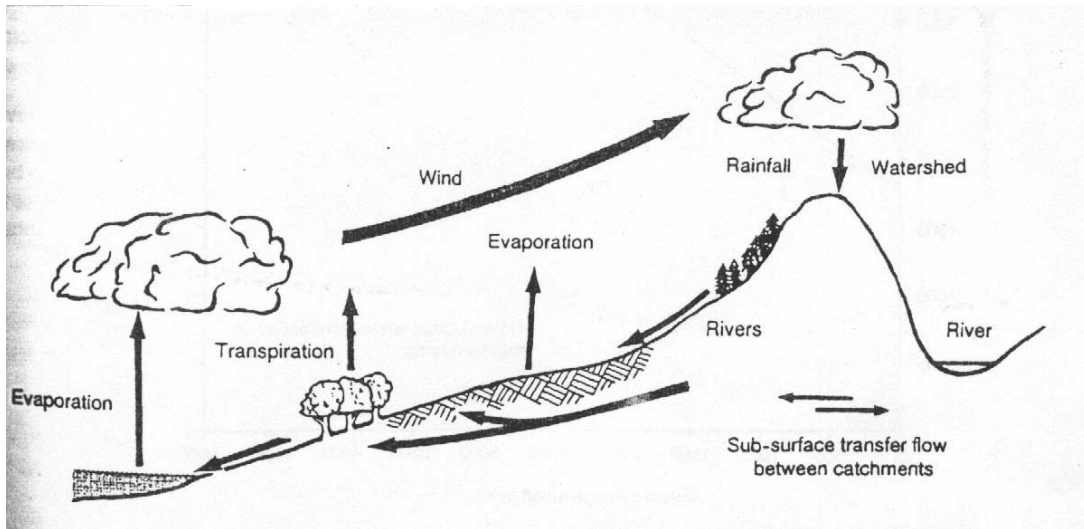

Figure 5-2 The Hydrological Cycle

5.2.2 THE FLOAT METHOD

This is a flow measurement method. As shown in Figure 5-3, the time taken for a float to travel a known distance on the surface of the stream is found and hence the mean velocity of the stream. The mean velocity depends on the bed surface of the stream and hence a correction factor is applied for the velocity given by the division of the float length by the time in calculating it. The mean cross sectional area of the stream is also found.

The flow is obtained by multiplying the mean values of cross sectional area and velocity.

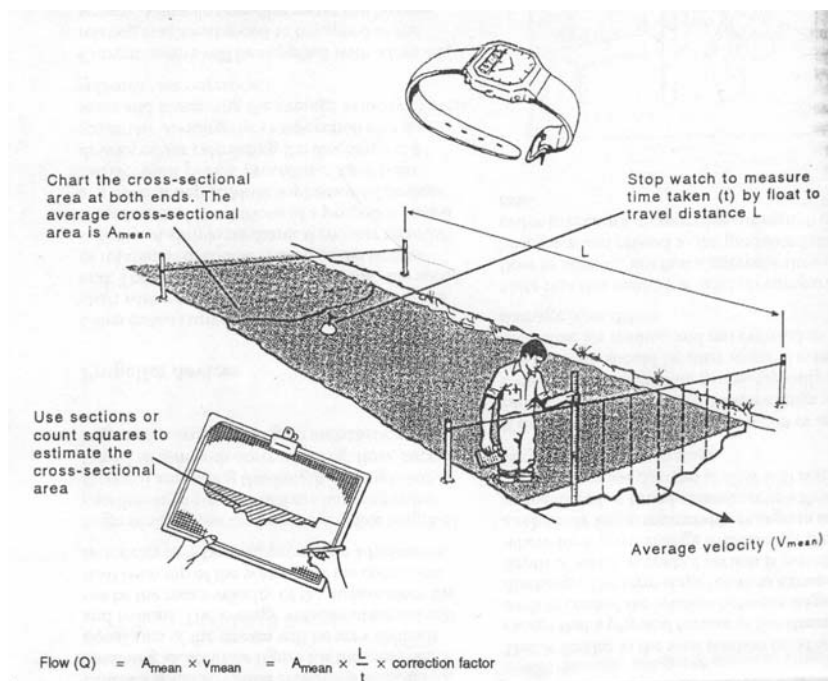

Figure 5-3 Float Method Of Flow Measurement

5.3 HEAD MEASUREMENT

5.3.1 PRESSURE GAUGE METHOD

Being not a very accurate method, pressure gauge method of head measurement employees a calibrated pressure gauge into which a long transparent water filled open ended pipe is fitted.

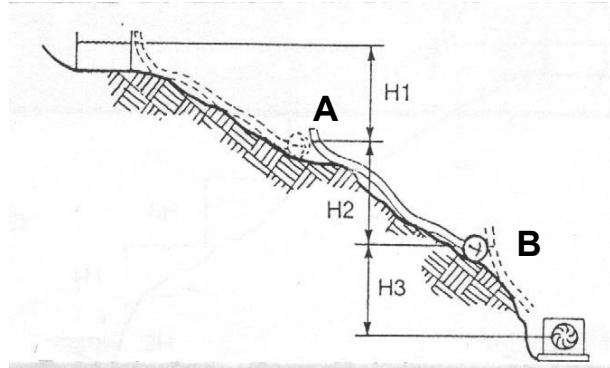

Figure 5-4 Pressure Gauge Method Of Height Measurement

Figure 5-4 shows how a pressure gauge is used in height measurement. The calibrated pressure gauge at B directly reads the pressure at point B with reference to point A. This reading can then be used to calculate the height difference between points A and B using the density of water.

The open end A of the pipe is then taken to point B and the meter can then be moved down to a point below the point B. This is done from the expected beginning to the expected end of the penstock and the head is calculated from the sum of reading of the meter.

5.3.2 TACHEOMETRIC SURVEYING

This is an accurate method of head measurement which uses an optical theodolite as shown in Figure 5-5.

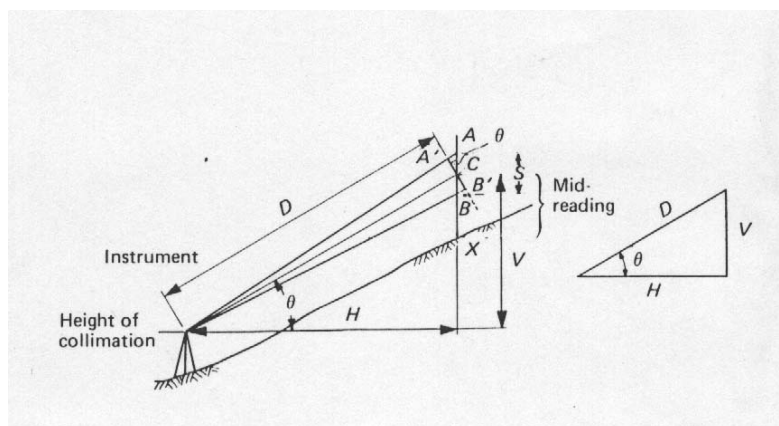

Figure 5-5 Tacheometric Surveying

A measuring staff is kept at point X and readings at points A, B and C which can be identified because of the cross hairs and stadia hairs of the instrument are taken. The inclination of the

lines of sight (θ) is also taken. These measurement can be mathematically manipulated to find the vertical and horizontal distances between the instrument and a given point. Thus a vertical profile along a path can be generated.

If a compass is additionally used at the instrument position to find the direction of point X relative to some reference direction (magnetic north), a bird's eye view of the surveyed path can also be drawn.

CHAPTER 6: MANUFACTURING CROSS FLOW TURBINES

6.1 INTRODUCTION

During the time of training, two similar 280kW cross flow turbines were manufactured in the Engineering Workshops. They were intended to be directly coupled to the generator as shown in Figure 6-1.

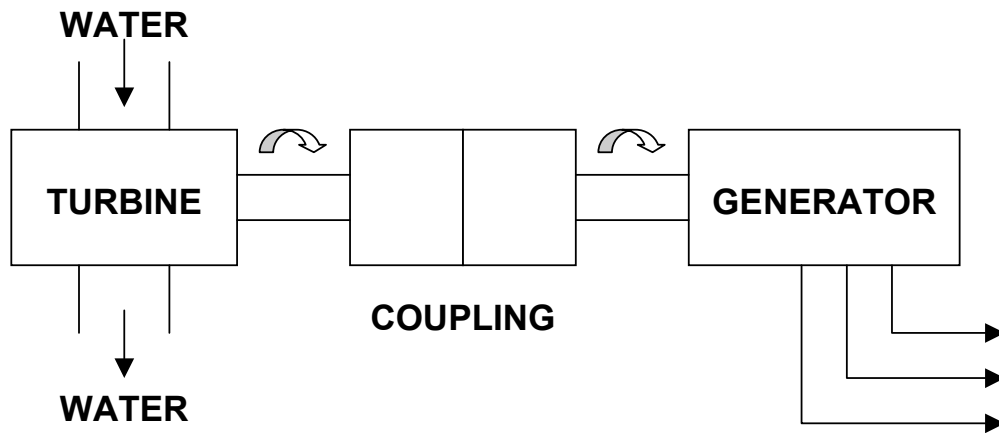

Figure 6-1 Direct Coupled Turbine

The following sections describe each component of the above system.

6.2 A CROSS FLOW TURBINE

Figure 6-2 shows the cross section of a cross flow turbine that had been manufactured earlier in the Engineering Workshops.

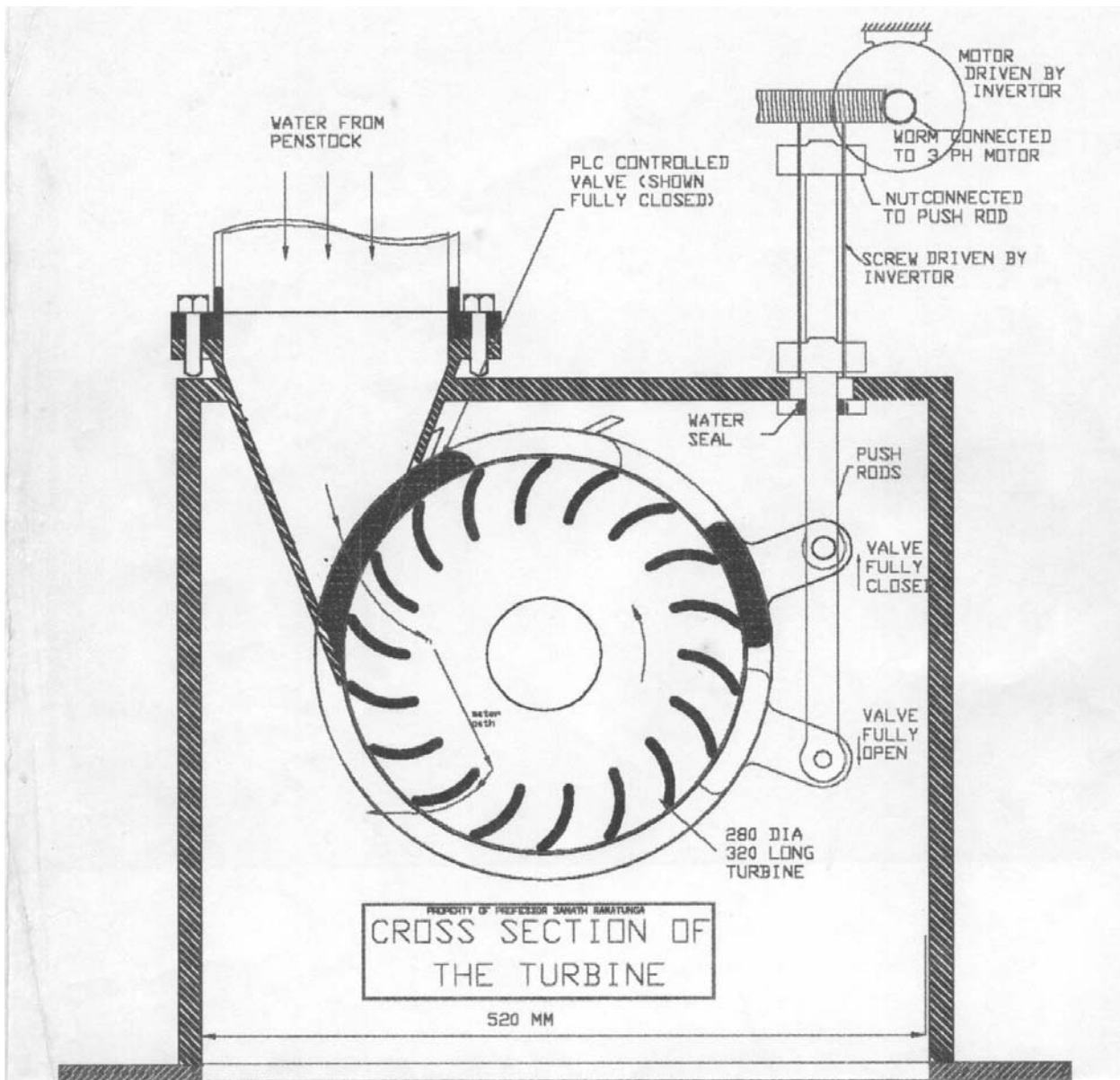

Figure 6-2 A Cross Flow Turbine

In a cross flow turbine, the blades are arranged in a squirrel cage. Water from the penstock hits a blade and travels across the cage, hits a second blade and leaves out. This is illustrated in Figure 6-2.

The turbine shown in Figure 6-2 has a governor connected to it internally. The latter produced ones do not contain governors.

Figure 6-3 shows the external dimensions of a 280kW cross flow turbine that was manufactured in the Engineering Workshops.

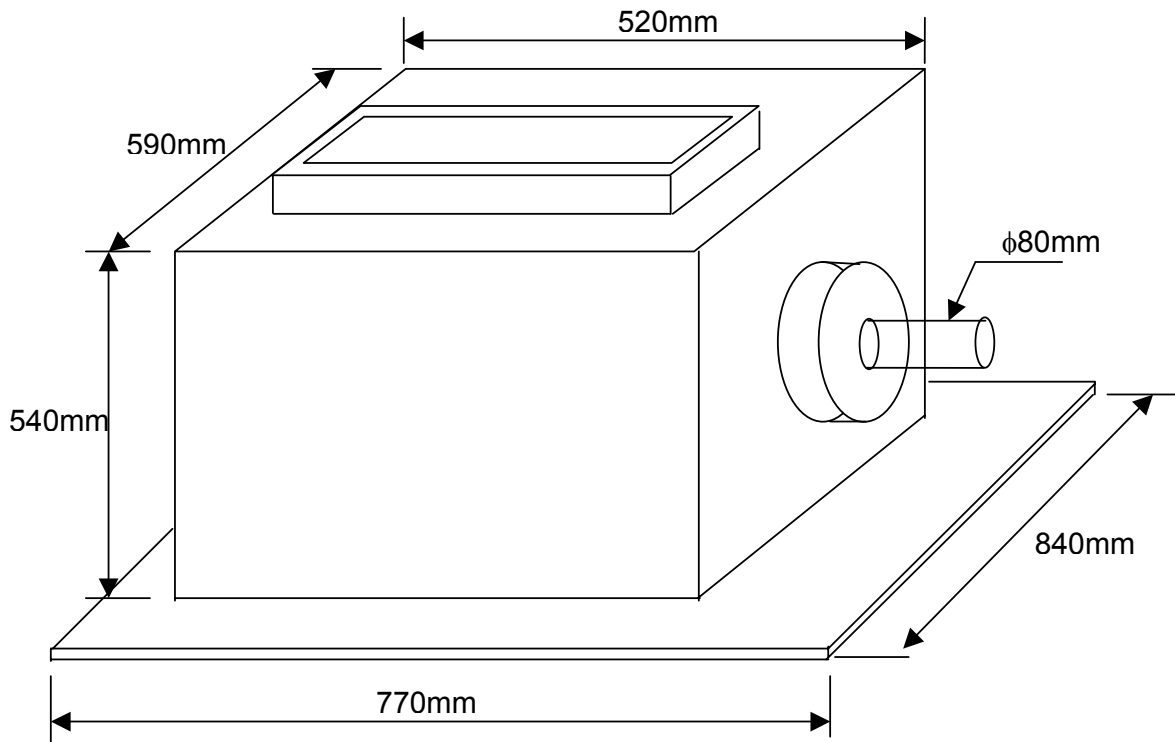

Figure 6-3 External Dimensions Of A 280kW Cross Flow Turbine

The squirrel cage blade structure of the turbine is kept in position by two bearings at each end of the rotor. The especial feature is that one of them is of self aligned type. A self aligned bearing allows the axis of the shaft which goes through it not to be the same axis of the outer fixed frame and the inclination may vary. This is shown in Figure 6-4.

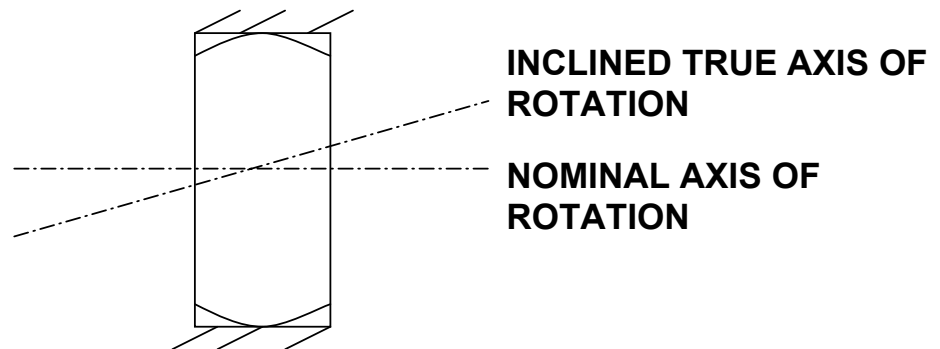

Figure 6-4 A Self Aligned Bearing

The self aligned bearing allows the manufacturing eccentricity of the bearing mounts not to cause vibrations or related mechanical failures.

6.3 COUPLINGS

The connection between the turbine and the generator is established by a set of cast iron couplings shown in Figure 6-5. Each of these couplings contains fifteen nylon bushes. Each bush on the turbine side coupling is connected to one bush on the generator side coupling using a metal rod. The nylon bush arrangement reduces vibrations and related failures due to possible eccentricities that may exist between two shafts.

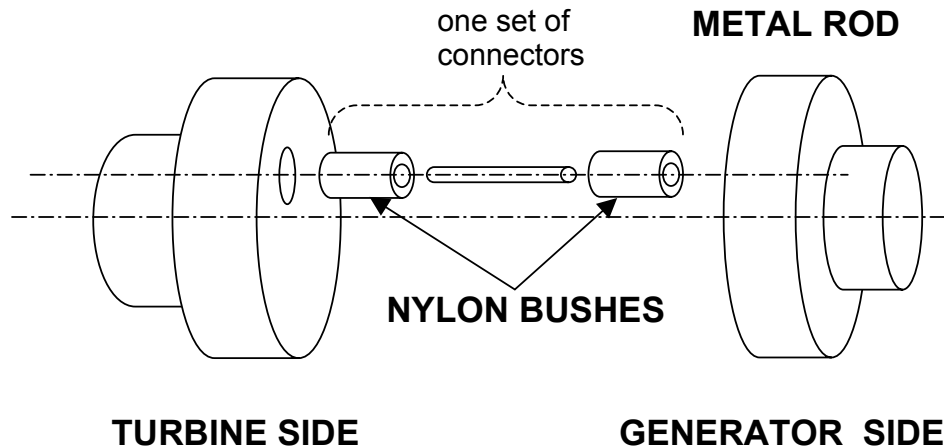

Figure 6-5 Coupling Between Turbine And Generator

6.4 GENERATOR

The alternator for an above turbine is of brushless self excited type with an automatic voltage regulator fitted into it. Figure 6-6 is a simple representation of such an alternator.

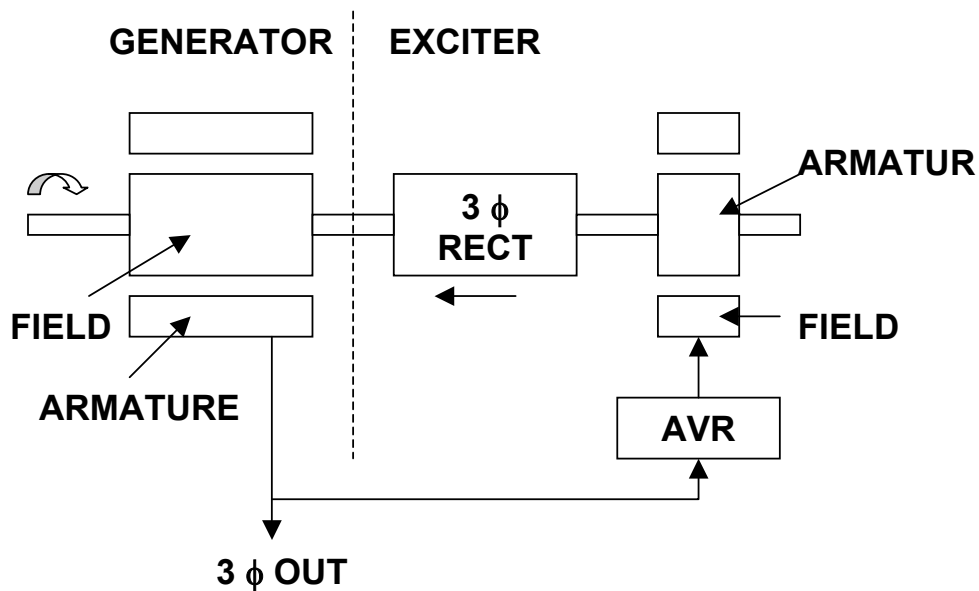

Figure 6-6 Brushless, Automatic Voltage Regulated Alternator

CHAPTER 7: OTHER ACTIVITIES

7.1 MANUFACTURING A CHALK MACHINE

The chalk machine that was being manufactured in the Engineering Workshops used a piston-cylinder arrangement in producing crayons. Made of brass, Figure 7-1 shows one such piston-cylinder pair.

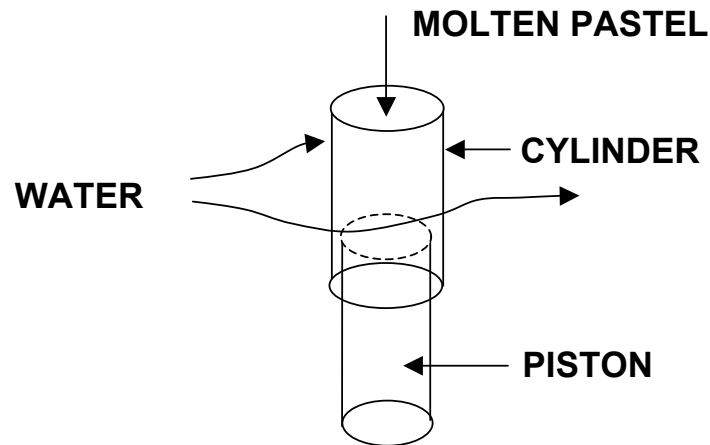

Figure 7-1 A Piston Cylinder Pair Of The Chalk Machine

The operation is as follows:

1. Fill the cylinders with molten pastel.
2. Pass water around the cylinders to solidify the crayons quickly.
3. Move the piston upwards to remove the crayons.

The machine contained a set of piston-cylinder pairs which worked simultaneously. Pressing the molten pastel into the cylinders and moving the piston upwards were performed by using two hydraulic jacks one on top and the other under the piston-cylinder structure.

7.2 SELF POWERED WATER PUMP FOR RIVERS

This is a design of Professor Sanath Ranathunga and I had no personal involvement with it.

A pipe is spiral wound inside a thrown away barrel as shown in Figure 7-2. The barrel is fitted with blades on its surface and submerged in the river. As the barrel rotates, water and air enter and pipe from its open end one after another. This pressurize the water inside the pipe and naturally elevates to a higher level.

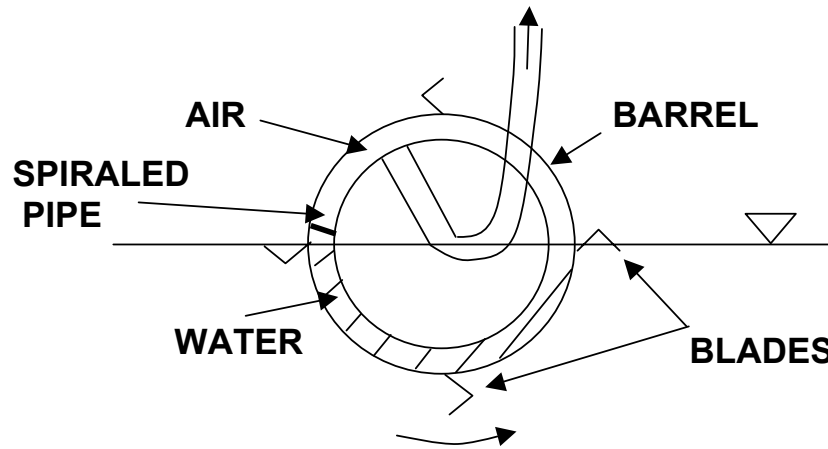

Figure 7-2 The Self Powered Water Pump For Rivers

7.3 MILLING A PRINTED CIRCUIT BOARD

The conventional way of creating a printed circuit board or PCB for short involves chemical etching of unwanted portions of copper from a copper clad board. Instead of using a chemical, milling away the unwanted portions of the copper surface reduces time and effort needed in creating PCBs drastically. Though some drawbacks exist, this was tried on the small universal milling machine and satisfactory results could be obtained.

First some broken tool shanks were found and ground to the shapes shown in Figure 7-3 using the drill bit grinder.

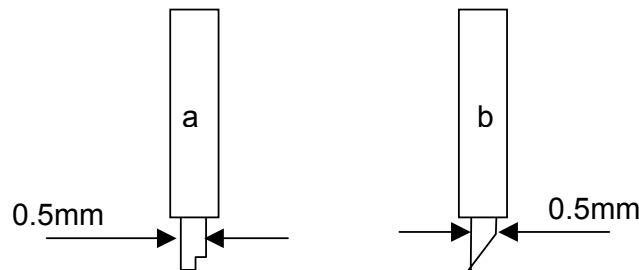

Figure 7-3 Tools To Mill A PCB

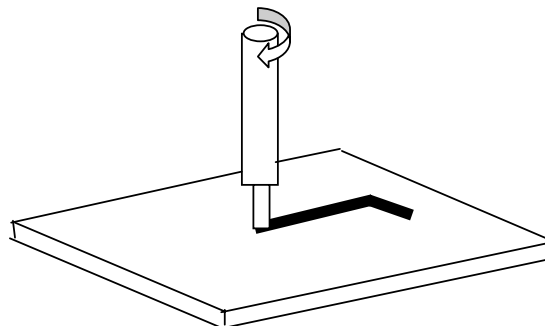

Figure 7-4 Milling A PCB

Cutter (a) in Figure 7-3 created a rough surface finish. The shape of the cutting edge of cutter (b) was seen to force the copper chips into the board producing a smooth surface finish.

7.4 AN ELECTRONIC ROTATION COUNTER

On request of the Workshops Director Dr. S.D. Pathirana, an electronic rotation counter was designed and assembled. This was intended to give a primitive idea of electronic counting to the engineering undergraduates who were not exposed to them before. In fact, the counter was supposed to be used as a teaching guide to teach the students automated motion controlling of machines.

The block diagram of the four digit counter is shown in Figure 7-5.

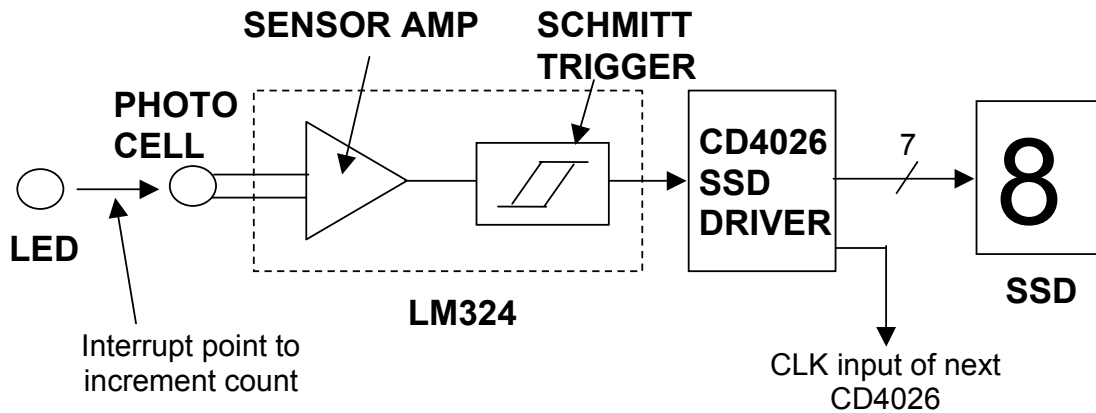

Figure 7-5 Electronic Rotation Counter

CD4026 is a decade counter and can drive a seven segment display (SSD) directly. The carry out pin of one IC is fed to the clock input of the next IC so that the count of next stage is incremented by 1 for 10 counts of this stage.

LM324 contains four general purpose operational amplifiers and used for the photo cell signal amplification and as a Schmitt trigger.

CHAPTER 8: ANNUAL PHYSICAL VERIFICATION OF STORES

At the end of each year, a physical verification of the stores is usually conducted and an inventory of items and prices is made.

The Annual Physical Verification Of Stores as at 31st December 1995 contained 1889 items listed alphabetically. The value of the items was Rs. 1 570 074.61. The price of the condemned items was Rs. 44 397.83 during the year.

It is interesting to note that the prices of the items were put as the prices existed when they were bought. For example a set of allen keys was only Rs. 25.00 the present value being around Rs. 600.00. In this sense, the present value of the stores might be around 40 million rupees. Usage of past prices of items in the inventory has no value at all. It just shows the total expenditure for the stores from the past. It would have been much more useful if the present prices of the items were used in the inventory.

CHAPTER 9: ADMINISTRATION, MANAGEMENT AND WELFARE

9.1 UNDERSTANDING THE ATTITUDES OF EMPLOYEES

Understanding the attitudes of employees is one of the most important aspects an engineer should gain in his carrier. Collaborating with employees with different mentalities is inherently difficult. Some of the points that were possible to discover are listed below.

- Different employees have different expectations from their jobs:
 - Faithful earning to live the life.
 - Just earning money to live the life.
 - Earning some extra money.
 - Acquiring experience for a better job position.
 - Acquiring the name of the current working organization in his curriculum vitae for a better job.
- While coming to the work, employees come with different mentalities:
 - Fresh mind and pleasure to work.
 - Burdened mind and unpleasant to work.
- Different personalities:
 - Living with the community.
 - Showing the existence.

9.2 JOB DISPATCHING AND ADMIRING THE WORK

Faithful job dispatching among the employees in the organization makes the environment pleasant for the employees to work and the administration becomes easier. In the Engineering Workshops job dispatching was done by the Workshop Engineer.

Though the organization had excessive human resources and workmen were given less tasks than they could carry, in some cases it was seen that some workmen saying “I have been given more work than others”. Some even said, “Since I am the only person who knows the subject I am always burdened with the work”. It was interesting to find out whether they state the truth.

In response to these statements a secret survey was conducted. Four workmen were selected including the ones who said that they were burdened and their work was observed in intervals of 15 minutes for two days. The results showed that they just lie. Some were not even possible to find for hours. One just signed the attendance register in the morning and evening and did nothing at all. Not a single was found to work at least quarter the nominal time period.

On the other hand, persons in the tool stores were truly burdened with work. They had to serve others all the times. In fact they disliked working there.

Whatever the case it was seen that workmen always tried to show the Workshops Director that they work. When the Director was not near by, workmen did there work in lethargy.

This was discussed with the Director and the final point was: “Yes, they want to show their boss that they work. Though a very little work is done, they are quite happy to be admired by me.”

In any case, accepting feedback from the employees and acting on them necessarily upholds the productivity of any organization.

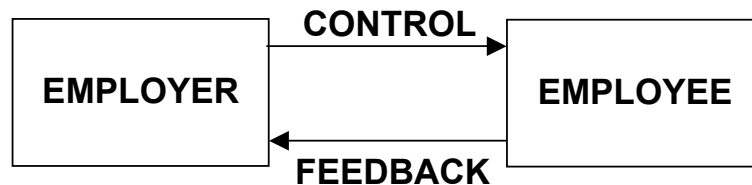

Figure 9-1 Listening To Feedback From Employees

9.3 GUIDE LINES FOR BETTERMENT

In some places of the Engineering Workshops guidelines for improving the performance of workmen could be found. Among them the ones that most people did not follow and the ones that should be followed are listed below:

Keep your eyes on the man ahead – you may be called on to take his place some day.

Read one or two of the technical magazines related to your line of work.

It was unfortunate to say that most guidelines were in English and many workmen did not understand them.

Furthermore a discussion with the Workshops Director revealed that earlier there were some sessions for the employees about implementing the Japanese S5 Concepts in the Workshops and they just died. Later he was seen refreshenning it by dividing the Workshops area among the workmen and allocating each area to several employees to maintain the enclosed machines. In Figure 9-2, the thick lines indicate the boundaries of the divided areas.

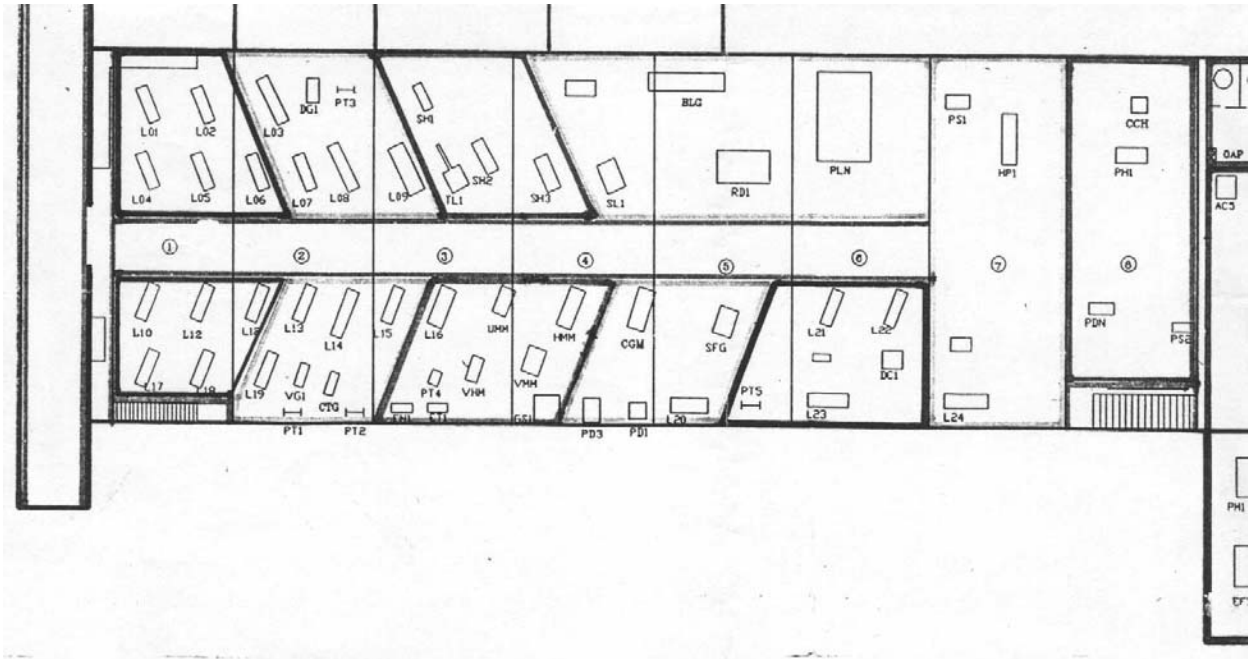

Figure 9-2 Division Of Flow Areas To Implement The Japanese S5 Concepts

9.4 FREEDOM AND WELFARE SOCIETIES WITH POLITICS

In the Engineering Workshops several welfare societies could be found. The Engineering Workshops Welfare Society united all the workmen in the Engineering Workshops. Furthermore some welfare societies formed at the university level could be found. Unfortunately these societies were heavily based on the political parties of the country. Depending on the political party one likes, he may join the related society. Freedom is lost and people get framed with the political party they like.

CHAPTER 10: PROBLEMS AND DIFFICULTIES ENCOUNTERED

Several problems and difficulties that were encountered during the training are listed below.

- Getting a job done by a lazy workmen:

Sometimes it was very difficult to find some workmen and get something done. Some workmen were inherently lazy and they seemed to be postponing their work giving various excuses. Following are some of their own words:

- Now it is the teatime.
- We will do it after the lunch.
- Mr. X may be working in the machine now and ask him to do the work.
- I will come soon.

- Stealing tools:

Sometimes it was found that tools suddenly disappear from the Workshops. It was not possible to find the person who took them and it was usual to see people pointing others leading to unpleasant situations.

Sometimes some workmen temporarily borrowed others' equipment and later just left them in the place they worked without returning them. When they were asked about them it was common to get the answer "I kept it right here. Somebody seems to have taken it".

- Collaboration problems with the workmen:

People differ. Some wanted to do their job disregarding others' jobs. On the other hand some just wanted to learn all the things in the Workshops doing nothing. Collaborating with them was difficult.

CHAPTER 11: CONCLUSION

11.1 CONCLUSION

The profit of an organization entirely depends on the way the top chairs manage the resources the organization has. Whatever the other aspects may be, it was seen that managing human resource was extremely difficult. The stability or the sustainability of the organization mostly depends on this factor.

On the other hand, it was prominently seen that thinking should precede doing. In most cases it could be seen that there exists easier or better ways to do something.

As far as the above mentioned factor is considered, continuous knowledge mining followed by experience in a cycle upholds the entire system in every aspect.

Earning and living a satisfactory life is the desire of all.

11.2 SUGGESTIONS FOR THE IMPROVEMENT OF THE ENGINEERING WORKSHOPS

The experiences I had in the Engineering Workshops suggest me the following to be implemented for the improvement of the place.

1. Maintain a simple booklet on materials that are used in the Engineering Workshops. This should contain the properties and the processing aspects (cutting speeds, coolants, etc.)
2. Maintain a booklet on each machine about the capabilities of them and the current condition.
3. Implement a method to return the unused consumable goods to the stores.
4. Maintain a training program for the employees at least one session a month.
5. Teach the employees how to collaborate with others.

11.3 SUGGESTIONS FOR THE IMPROVEMENT OF TRAINING PROGRAM

A group of 14 undergraduates including myself had the first year in-plant training at the Faculty Workshop together and all of us did what we were supposed to do separately. Though we discussed what we were doing among ourselves a little, I feel it would have been better if we were explicitly encouraged by the Industrial Training Unit to had formal discussions at least once a week. Some of the undergraduates (I feel I was one of that group) were seen to work harder gaining more knowledge and the real taste of engineering and some were not. If discussions of this nature were conducted, all of us could have gained a better knowledge and improved ourselves collectively. The participation of the training supervisor would have been a further encourage.

Furthermore I suggest that it would have been better if all the undergraduates were exposed to some presentations on the in-plant training before we were released. Some illustrative

aspects of practical engineering could have been discussed widening the openness of the eyes of us. Though we new what engineering was, we were not exposed to any sort of practical engineering when we went for the training.

**APPENDIX A: FEASIBILITY REPORT ON THE
PROPOSED MINI-HYDRO POWER PROJECT AT
KABARAGALA ESTATE**

FEASIBILITY REPORT
ON THE PROPOSED
MINI-HYDRO POWER PROJECT
AT KABARAGALA ESTATE

SUPERVISED BY:

**PROFESSOR SANATH RANATHUNGA
FACULTY OF ENGINEERING
UNIVERSITY OF PERADENIYA
PERADENIYA
SRI LANKA**

PARTICIPANTS:

**MR. SARATH PERERA
MR. MAHANAMA DHARMAWARDANA
MR. GUNARATHNA PMCWK
MR. WASANTHALAL MA
MR. WICKRAMANAYAKE HMKSK
MR. DORATIYAWA PB**