

STATE OF TEXAS

**VEHICLE DAMAGE GUIDE FOR
TRAFFIC CRASH INVESTIGATORS**

2015 EDITION



TEXAS DEPARTMENT OF TRANSPORTATION

Traffic Operations Division – CDA

CR-80

01/01/2015

Version 1.2

This Page Intentionally Left Blank

Table of Contents

- DOCUMENT INFORMATION, VERSION CONTROL..... 1
- INTRODUCTION..... 2
- 1.0 DETERMINING THE VEHICLE DAMAGE RATING..... 3
 - 1.1 Vehicle Damage Rating 3
- 2.0 USING THE VEHICLE DAMAGE SCALE 4
 - 2.1 Vehicle Damage Scale 4
 - 2.2 Damage Description Code..... 4
 - 2.3 Damage Severity Code 4
 - 2.4 Exceptions 4
 - 2.5 Establishing Damage Description and Severity Rating 5
- 3.0 DIRECTION OF FORCE CODE..... 7
 - 3.1 Direction of Force Code 7
 - 3.2 Determining Direction of Force..... 7
 - 3.3 Clockpoint Diagram for Motor Vehicle..... 7
 - 3.4 Impact Points..... 8
- 4.0 VEHICLE DAMAGE INDEX 14
- 5.0 VEHICLE DAMAGE SCALE..... 17
- If you have any questions or need further clarification, please contact: 29

DOCUMENT INFORMATION, VERSION CONTROL

Date	Version	Author(s)	Section(s)	Update(s)
1/1/2015	1.2	R. Holt, D. Plummer	All	Add Table of Contents, add Version Control page, revise Contact Information, formatting, corrected title page.

INTRODUCTION

The Texas Department of Transportation (TxDOT) has developed this Vehicle Damage Guide for Traffic Crash Investigators to assist Texas law enforcement agencies in correctly assessing damage sustained by motor vehicles in traffic crashes and accurately entering the Vehicle Damage Rating on the Texas Peace Officer's Crash Report (CR-3).

This guide is based on information contained in the American National Standards Institute (ANSI) D16.1 Standard, 2007 Manual on Classification of Motor Vehicle Traffic Accidents, 7th edition and the 2003 Model Minimum Uniform Crash Criteria (MMUCC) Guideline, 2nd edition, as primary sources for definitions, classifications of crashes and related diagrams. The MMUCC Guideline is the collaborative publication of the National Highway Traffic Safety Administration, the Federal Motor Carrier Safety Administration, the Federal Highway Administration, and the Governors Highway Safety Association.

This guide consists of diagrams, descriptions and photographs of damaged automobiles representing a variety of common impacts that investigators are likely to encounter. Diagrams and symbols are provided to assist with an accurate determination of vehicle damage.

Prepared and Distributed by:

Texas Department of Transportation
Traffic Operations Division - CDA
PO Box 149349
Austin, TX 78714-9349

1.0 DETERMINING THE VEHICLE DAMAGE RATING

The Vehicle Damage Rating for motor vehicles involved in crashes is shown by sequentially entering three (3) separate values on the Texas Peace Officer's Crash Report (CR-3). A diagram showing the components of the Vehicle Damage Rating is shown below.

27
Vehicle
Damage Rating 1 <input type="text"/> <input type="text"/> - <input type="text"/> <input type="text"/> <input type="text"/> - <input type="text"/>

X X A B C Y

1.1 Vehicle Damage Rating is reported so that some correlation between direction and amount of impact force with the severity of injury and restraining device used can be established. The direction of force is not required; however, agencies choosing to complete this portion of the vehicle damage rating field must use the prescribed format.

- **Direction of Force – (XX)** – Describes the direction from which the vehicle damage was received in comparison to the numbers on a clock. Should be shown with a 1 or 2-digit numeric character (1–12) before the damage description and right justified.
- **Damage Description – (ABC)** – Describes the area of the vehicle that received damage. Should be reported with a 2 or 3 alpha character code and right justified.
- **Damage Severity – (Y)** – Describes the severity of the damage received. Should be reported with a single-digit numeric character between 0 and 7 after the damage description.

2.0 USING THE VEHICLE DAMAGE SCALE

2.1 Vehicle Damage Scale is used to determine the Damage Description Code and the Damage Severity Code that the investigator will enter as part of the Vehicle Damage Rating on the CR-3. The Direction of Force Code, which precedes the Damage Description Code and the Damage Severity Code in the Vehicle Damage Rating, is discussed in Section 3.0 of this guide.

2.2 Damage Description Code, a two or three-letter Damage Description Code (FC, LBQ, etc.) displayed in the upper right, upper left, and lower left corner of each page of the Vehicle Damage Scale, indicates the part of the vehicle that received the damage and the type of impact that caused the damage.

- For example, the Damage Description Code “FC” indicates that the vehicle received front-end damage from a concentrated impact, corresponding to the type of impact resulting from a collision with a tree, utility pole, or other narrow object. In addition, a diagram of a car and an arrow, or series of arrows, on the left side of the page, shows the direction of the principal impact force.

2.3 Damage Severity Code is entered as a single-digit numeric character between 0 and 7, where 0 represents the least damage and 7 the greatest. If a vehicle sustained no discernible damage, a “0” rating should be reported. The “0” rating is generally applicable to collisions of motor vehicles with pedestrians or bicycles or to non-collision crashes.

- Note: In cases where vehicles are damaged in more than one area, the investigator should enter the description of the two (2) most severely damaged areas, beginning with the area showing the most severe damage (Example: “FD-6, BD-3”).

2.4 Exceptions shall be utilized when vehicles acquire damage from occurrences other than the types of impacts described in the damage description table.

- **VB-1** - vehicle burned, NOT due to collision (engine catches fire, cigarette burns upholstery, etc.).

- **VB-7** - vehicle catches fire due to the collision (vehicle collides with object or another vehicle and fire starts).
- **TP-0** - top damage only.
- **VX-0** - undercarriage damage only.
- **MC-1** - motorcycle, moped, scooter, etc.
- **N/A** - farm tractor, train, pedalcyclist, wheelchair, motorized conveyance, streetcar, animal carrying person, etc.

2.5 Establishing Damage Description and Severity Rating

In order to establish a damage description and damage severity rating, the crash investigator must first select the proper page from the Vehicle Damage Index in 4.0 of this guide to match the damage to the vehicle. The type of collision will determine the selection.

For example, if the investigator is reporting on an angle collision that occurred at an intersection, and the front end of a vehicle struck another vehicle on the left side, the investigator can refer to the Vehicle Damage Index to find the diagram that most accurately describes the impact on the first vehicle. In this case, it may be the diagram that shows distributed impact on the front end. In the column headed "Description", the damage description "FD" tells the investigator what page of pictures should be used in determining the damage severity rating. For convenience, the pages are arranged in the same order as their designators appear in the index.

The next step is to compare the damage on the vehicle with a photograph on the selected page of the Vehicle Damage Scale in 5.0. If, for example, the front-end damage on the first vehicle appears to match that on the bottom photograph on the page labeled "FD" (front-end damage, distributed impact), the damage description and severity rating would be "FD-6". However, if the damage is more severe than the damage in the photo adjacent to "FD-6", the damage description and severity rating of "FD-7" should be used; and if less severe, but greater than "FD-4", the rating should be "FD-5".

The procedure for rating the damage on the vehicle that was struck on its left side is similar, except that the investigator must determine what part of the left side was struck before selecting the proper page of photographs depicting the damage. The impact diagrams in the Vehicle Damage Index facilitate this determination.

If the vehicle was struck broadside in the area of the passenger compartment, the investigator would use the page headed "LP/RP" to determine the damage severity rating. However, if the impact occurred in the area ahead of the passenger compartment, the page headed "LFQ/RFQ" (left front quarter/right front quarter) would be proper to use; and if the impact occurred behind the passenger compartment, the "LBQ/RBQ" (left back quarter/right back quarter) would be used.

Should the investigator decide that the second vehicle in the example collision was struck broadside in the area of the passenger compartment, the entry on the crash report form would be "LP-(with the appropriate damage severity rating)". If the second vehicle was struck on the right side instead of the left side, the investigator would use the page titled "LP/RP". The investigator would then enter "RP-(with the appropriate damage severity rating)" on the crash report form.

Dual descriptions such as LP/RP, LBQ/RBQ, FL/FR, and BL/BR mean that the pages may be used for describing damage to either the left or right sides of the vehicle. The investigator should exercise care in writing the damage description so that there will be no question as to what side or corner was damaged.

3.0 DIRECTION OF FORCE CODE

3.1 Direction of Force Code describes the angle at which the vehicle received damage, and is the first field captured when describing vehicular damage in the Vehicle Damage Rating (see diagram in 1.0). This is the field that represents the *impact point*. A rough description of direction of force is provided by the damage description letter code in the Vehicle Damage Scale. However, for investigators who prefer a more precise scheme for indicating direction of force, the investigator may assign a one or two-digit numeric code corresponding to the numbers on a clock that represents the direction at which the vehicle received damage.

3.2 Determining Direction of Force - In order to determine the direction of force, the investigator must imagine a superimposed circle around the vehicle, with numbers as on a clock. Each number (1-12) represents a direction or angle in which the vehicle may have received damage. See the following diagram for determining the number value indicating direction of force for motor vehicles.

3.3 Clockpoint Diagram for Motor Vehicle

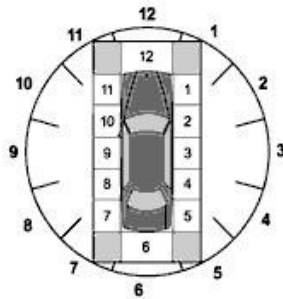

The clockpoint diagram above shows direction of force for a motor vehicle. For example, the direction of force for a vehicle involved in a head-on collision where force is received by the front of the vehicle would be a 12. Direction of force for a vehicle receiving damage directly from behind would be a 6. A perpendicular hit to the driver's side of the vehicle would be shown as a 9 and a perpendicular hit to the passenger's side would be shown as a 3.

3.4 Impact Points

To be compatible, the direction of force and damage description codes entered on the CR-3 crash report form must correspond to the appropriate side of the vehicle (left, right, front or rear). In other words, a direction of force code of “3” and a damage description code of “LP” (3-LP) are *incompatible*, because “LP” is the code for “Left Panel” and the direction of force code “3” is associated with damage to the *right* side of the vehicle as indicated on the chart below. Any of the below numbers that are used should precede the letter code to prevent any confusion with the Damage Severity Code, which follows the letter code (See 2.0 of this guide). Inclusion of direction of force codes is shown in the following examples:

12-FC-3, 9-LP-2, 6-BD-4

Compatible Impact Points for Direction of Force

Impact Points correspond to the numbers on the clock point diagram shown on the previous page of this guide to indicate the direction of force from which damage was received. The numbers 3 and 9 indicate a perpendicular impact to the sides of the vehicle, the number 6, a perpendicular impact to the rear of the vehicle, and the number 12, a perpendicular impact to the front of the vehicle.

Right Side

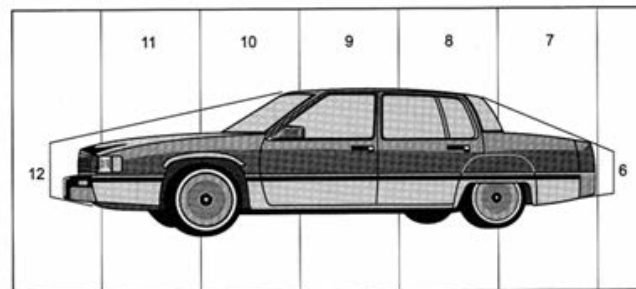
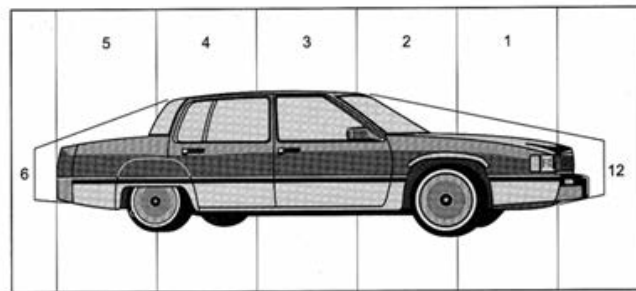

Left Side

Diagram 1

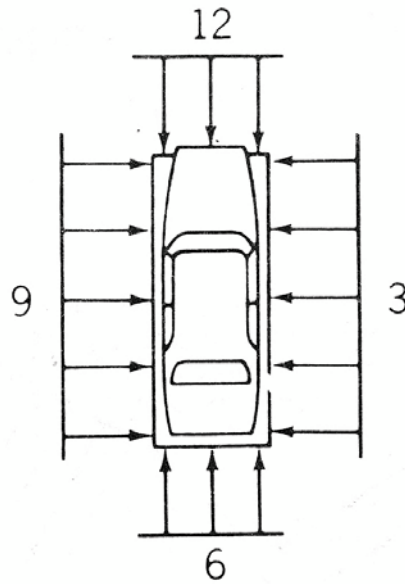

In Diagram 1, the direction of force codes indicated by numbers 3, 6, 9, and 12 are approximately perpendicular to the vehicle. Compatible direction of force codes and damage description codes are shown in the table below.

12-FC	3-RBQ	6-BC	9-LBQ
12-FD	3-RFQ	6-BD	9-LFQ
12-FL	3-RP	6-BL	9-LP
12-FR	3-R&T	6-BR	9-L&T

Any other letter code combined with any of the above numbered codes should be considered as incompatible.

Diagram 2

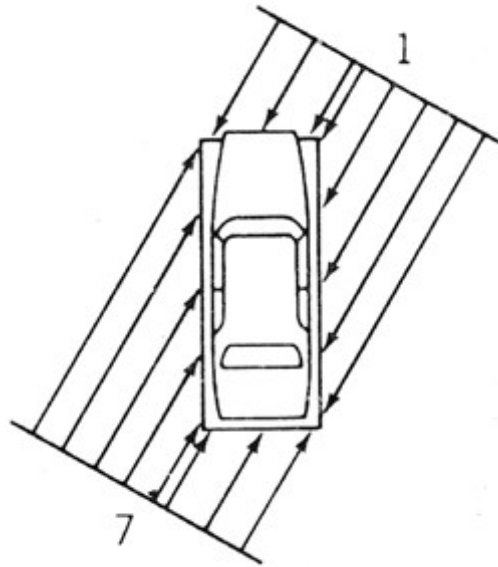

In Diagram 2, the direction of force codes indicated by numbers 1 and 7 are isolated. Below are combinations of compatible codes.

1-FC	7-BC
1-FL	7-BL
1-FR	7-BR
1-RBQ	7-LBQ
1-RFQ	7-LFQ
1-RD	7-LD
1-RP	7-LP

Diagram 3

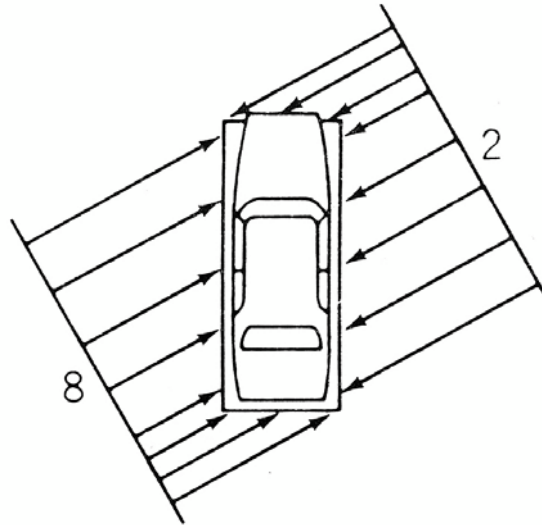

In Diagram 3, the direction of force codes indicated by numbers 2 and 8 are isolated. Below are combinations of compatible codes.

2-FC	8-BC
2-FL	8-BL
2-FR	8-BR
2-RBQ	8-LBQ
2-RFQ	8-LFQ
2-RP	8-LP

Diagram 4

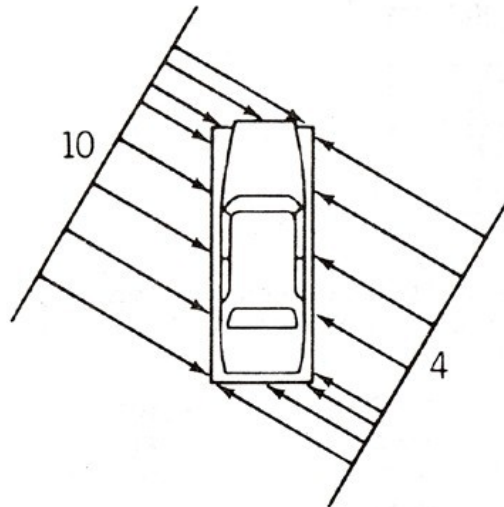

In Diagram 4, the direction of force codes indicated by numbers 4 and 10 are isolated. Below are combinations of compatible codes.

4-RBQ	10-RBQ
4-RFQ	10-LFQ
4-RP	10-LP
4-BL	10-FC
4-BR	10-FL
4-BC	10-FR
5-BC	11-FR

Diagram 5

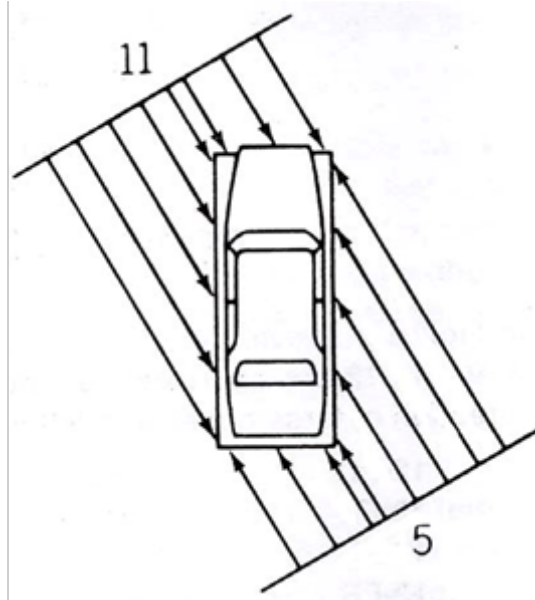

In Diagram 5, the direction of force codes indicated by numbers 5 and 11 are isolated. Below are combinations of compatible codes.







5-RBQ	11-RBQ
5-RFQ	11-LFQ
5-RD	11-LD
5-RP	11-LP
5-BL	11-FC
5-BR	11-FL

4.0 VEHICLE DAMAGE INDEX

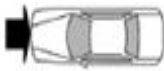
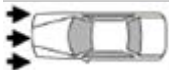
The Vehicle Damage Index is used by the investigating officer to determine which page of the Vehicle Damage Scale in 5.0 of this guide best represents the damage to the vehicle. In order to establish a damage severity rating, the crash investigator must first select the proper page from the Index to match the vehicle damage. The type of collision will determine the selection.

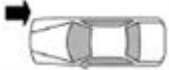
Diagrams of cars and arrows on the left side of the chart show the directions of the principal impact force. The "Type of Impact" in the second column provides a detailed description of the type of damage associated with the impact. Corresponding damage description codes are listed in the columns on the right side of the chart.

Vehicle Damage Index

Type of Impact (Front to Rear End Damage)	Description	
	<p>Front end damage due to concentrated impact resulting from collision of subject vehicle with tree, utility pole, or other narrow object.</p>	FC
	<p>Front end damage due to distributed impact resulting from full contact of front end of subject vehicle with other vehicle or broad object.</p>	FD
	<p>Front left corner damage due to partial contact of front end of subject vehicle with other vehicle or object.</p>	FL
	<p>Front right corner damage due to partial contact of front end of subject vehicle with other vehicle or object.</p>	FR
	<p>Rear end damage due to concentrated impact resulting from collision of subject vehicle with tree, utility pole, or other narrow object.</p>	BC
	<p>Rear end damage due to distributed impact resulting from full contact of rear end of subject vehicle with another vehicle or object. Applicable to rear-end collisions.</p>	BD
	<p>Rear left corner damage due to partial contact of rear end of subject vehicle with another vehicle or object. Applicable to rear-end collisions.</p>	BL
	<p>Rear right corner damage due to partial contact of rear end of subject vehicle with another vehicle or object. Applicable to rear-end collisions.</p>	BR

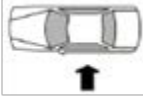
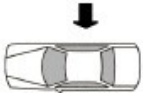
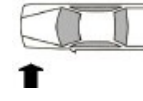
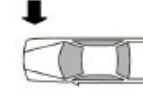
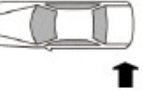
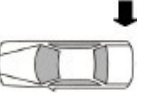
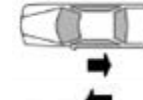
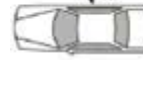
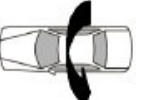
Type of Impact (Side and/or Top Damage)	Description	
	<p>Left side damage in vicinity of passenger compartment due to angular impact by another vehicle or object. Applicable to angle collisions and crashes in which a vehicle strikes an object after skidding or spinning.</p>	LP
	<p>Right side damage in vicinity of passenger compartment due to angular impact by another vehicle or object.</p>	RP
	<p>Left front quarter damage (ahead of passenger compartment) due to angular impact by another vehicle or object. Applicable to angle collisions and crashes in which a vehicle strikes an object after skidding or spinning.</p>	LFQ
	<p>Right front quarter damage (ahead of passenger compartment) due to angular impact by another vehicle or object.</p>	RFQ
	<p>Left rear quarter damage (behind passenger compartment) due to angular impact by another vehicle or object. Applicable to angle collisions and crashes in which a vehicle strikes an object after skidding or spinning.</p>	LBQ
	<p>Right rear quarter damage (behind passenger compartment) due to angular impact by another vehicle or object.</p>	RBQ
	<p>Left side damage resulting from sideswipe by meeting or overtaking other vehicle or object.</p>	LD
	<p>Right side damage resulting from sideswipe by meeting or overtaking other vehicle or object.</p>	RD
	<p>Left side and top damage due to rollover. Right side and top damage due to rollover.</p>	L&T R&T

5.0 VEHICLE DAMAGE SCALE

The Vehicle Damage Scale on the following pages is used by crash investigators to determine the severity of damage to motor vehicles involved in traffic crashes. The Vehicle Damage Index in 4.0 may be used to determine which page of the scale the investigator should refer to for damage resulting from specific types of crashes (see 2.0 of this guide for information on how to use the Vehicle Damage Scale).

Damage Description
FC

Front End Damage
Concentrated Impact

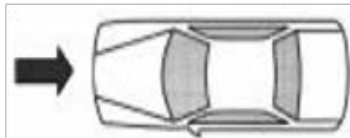

This scale is applicable to damage to the front of the subject vehicle resulting from a collision with a tree, utility pole, or other narrow object.

Damage Description and Severity Codes

FC – 1



FC – 2

FC – 3



FC – 4

FC – 5

FC – 6



FC – 7

Damage Description
FD

Front End Damage
Distributed Impact

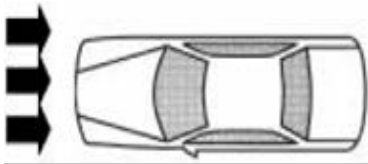

This scale is applicable to damage to the front of the subject vehicle due to distributed impact resulting from full contact with another vehicle or broad object.

Damage Description and Severity codes

FD – 1



FD – 2

FD – 3



FD – 4

FD – 5

FD – 6



FD – 7

**Damage Description
FL/FR**

**Front End Damage
Partial Contact**

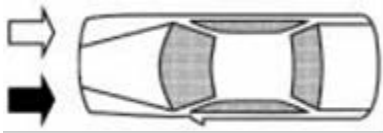

This scale is applicable to damage resulting from partial contact of the front end (left front corner or right front corner) of the subject vehicle with another vehicle or object.

**Damage Description and
Severity codes**

FL or FR – 1



FL or FR – 2

FL or FR – 3



FL or FR – 4

FL or FR – 5

FL or FR – 6



FL or FR – 7

Damage Description
BC

RearEnd Damage
Concentrated Impact

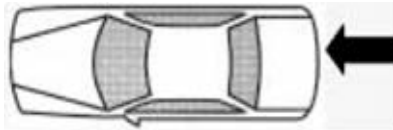

This scale is applicable to damage to the rear of the subject vehicle resulting from a collision with a tree, utility pole, or other narrow object.

Damage Description and Severity codes

BC – 1



BC – 2

BC – 3

BC – 4



BC – 5

BC – 6

BC – 7



Damage Description
BD

Rear End Damage
Distributed Impact

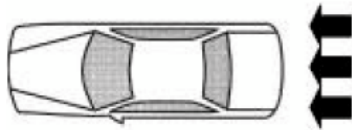

This scale is applicable to damage to the rear of the subject vehicle resulting from full contact of the rear end of the subject vehicle with another vehicle or object.

Damage Description and Severity codes

BD - 1



BD - 2

BD - 3



BD - 4

BD - 5

BD - 6

BD - 7

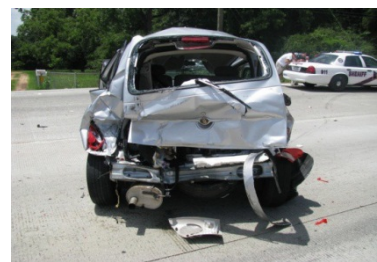

Damage Description
BL/BR

Rear End Damage
Partial Contact

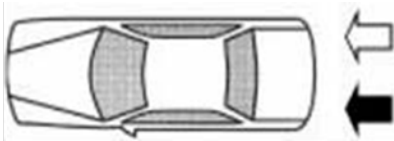

This scale is applicable to damage resulting from partial contact of the rear end (left rear corner or right rear corner) of the subject vehicle with another vehicle or object.

Damage Description and Severity codes

BL or BR – 1

BL or BR – 2

BL or BR – 3

BL or BR – 4

BL or BR – 5

BL or BR – 6

BL or BR – 7



Damage Description
LP/RP

Side Damage
Angular Impact

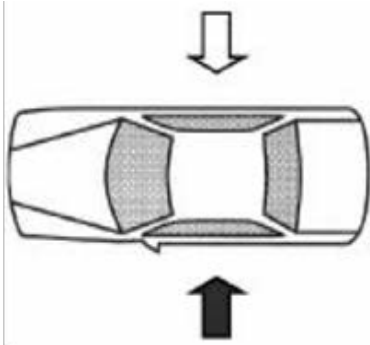

This scale is applicable to damage to the side in the vicinity of the passenger compartment of the subject vehicle resulting from an angular impact by another vehicle or object.

Damage Description and Severity codes

LP or RP – 1

LP or RP – 2

LP or RP – 3

LP or RP – 4

LP or RP – 5

LP or RP – 6

LP or RP – 7



Damage Description
LFQ/RFQ

Front Quarter Damage
Angular Impact

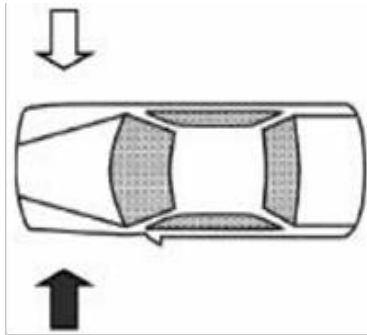

This scale is applicable to damage to the left or right front quarter of the subject vehicle (ahead of the passenger compartment) resulting from an angular impact by another vehicle or object.

Damage Description and Severity codes

LFQ or RFQ – 1

LFQ or RFQ – 2

LFQ or RFQ – 3

LFQ or RFQ – 4

LFQ or RFQ – 5

LFQ or RFQ – 6

LFQ or RFQ – 7

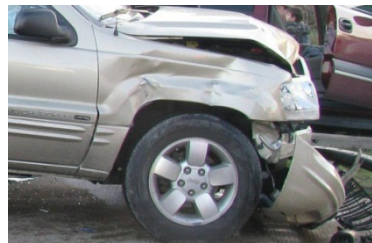

Damage Description
LBQ/RBQ

Rear Quarter Damage
Angular Impact

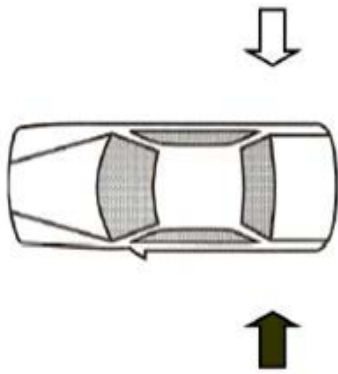

This scale is applicable to damage to the left or right rear quarter of the subject vehicle (behind the passenger compartment) resulting from an angular impact by another vehicle or object.

Damage Description and Severity codes

LBQ or RBQ – 1



LBQ or RBQ – 2

LBQ or RBQ – 3

LBQ or RBQ – 4



LBQ or RBQ – 5

LBQ or RBQ – 6

LBQ or RBQ – 7



Damage Description
LD/RD

Distributed Side
Damage - Parallel Impact

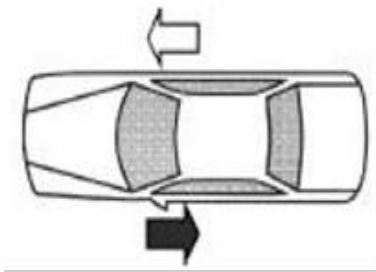

This scale is applicable to damage to the left or right side of the subject vehicle resulting from a sideswipe with another vehicle or object.

Damage Description and Severity codes

LD or RD – 1

LD or RD – 2

LD or RD – 3

LD or RD – 4

LD or RD – 5

LD or RD – 6

LD or RD – 7



Damage Description
L&T/R&T

Side and Top Damage
Roll-over Effects

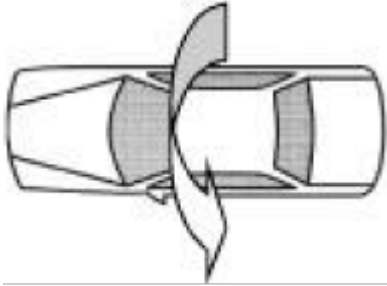

This scale is applicable to damage to the left or right side and top of the subject vehicle resulting from a rollover.

Damage Description and Severity codes

L&T or R&T – 1

L&T or R&T – 2

L&T or R&T – 3

L&T or R&T – 4

L&T or R&T – 5

L&T or R&T – 6

L&T or R&T – 7



If you have any questions or need further clarification, please contact:

(844) CRIS-HLP, (844-274-7457)

support@crishlp.com

Mail crash reports to:

Texas Department of Transportation
Traffic Operations Division - CDA
PO Box 149349
Austin, TX 78714-9349

To obtain crash forms go to:

<http://www.txdot.gov/inside-txdot/forms-publications/drivers-vehicles/forms/crash-records.html>

To obtain Crash Data Analysis and Statistical Data:

<http://www.txdot.gov/inside-txdot/division/traffic/crash-statistics.html>