

— × GED Study Guide

+ = MATH

What you need to know about the GED® Math Test

- 1** You should be familiar with arithmetic and math concepts, measurements, equations, and applying math concepts to solve real-life problems.
Remember, the math test is not a memorization test! You'll have access to a formula sheet that gives you information like how to calculate the area for different shapes.
- 2** This study guide and the example questions in it will help you get an idea of what's going to be on the test.
- 3** You don't need to know everything in this guide!
If you want to see how close you are to passing, the GED Ready® official practice test is a great way to help you determine if you're ready.

Test Overview



Topics

Basic Math
Geometry
Basic Algebra
Graphs and Functions



Time (to take the test)

115 minutes
3 minute break between parts (to retrieve your calculator)



Format

2 parts
Calculator allowed for part 2
Access to calculator reference sheet and math formula sheet
Multiple choice and other question types (drag and drop, fill in the blank, hot spot, and drop down)

What you'll be tested on

[†] The GED test will measure your strength in the skills below. Click on a skill to learn more about it.



Basic Math



1 Fractions and decimals in order

Place fractions and decimals in order.

For example, you can order the set of numbers:

$$\frac{1}{4}, 0.5, \frac{3}{8}, 0.9$$

in order from smallest to largest:

$$\frac{1}{4}, \frac{3}{8}, 0.5, 0.9$$

Example Questions

Fractions and decimals in order

Question:

Between which pair of decimals should $\frac{4}{7}$ be placed on a number line?

- A 0.3 and 0.4
- B 0.4 and 0.5
- C 0.5 and 0.6
- D 0.6 and 0.7

2 Multiples and factors

Find multiples and factors.

For example:

- the least common multiple of 3 and 5 is 15
- the greatest common factor of 12 and 30 is 6

Example Questions

Multiples and factors

Question:

Susan and Daphne are participating in a walk-a-thon at the local community college track to raise money. Susan can walk around the track in 4 minutes. Daphne can walk around the track in 6 minutes. Susan and Daphne started walking at the same time. How many minutes will it be until they complete a lap at the same time?

- A 2
- B 10
- C 12
- D 24

3 Simplify exponents

Simplify numerical expressions with exponents

For example, $2^6 \times 2^5 = 2^{11}$

Example Questions

Simplify exponents

Question:

Simplify.

$$(2^9 \times 3^5) \times (2^4 \times 3)^2$$

- A 6^{20}
- B 6^{24}
- C $2^{13} \times 3^7$
- D $2^{17} \times 3^7$

4 Distance between numbers on a number line

Find the distance between numbers on a number line using absolute value.

For example, on a number line with points plotted at -2 and 4, the distance between the points is 6.

Example Questions

Distance between numbers on a number line**Question:**

The points -4 and 5 are plotted on a number line. What is the distance, in units, between the two points?

A 1

B 4

C 8

D 9

5 Whole numbers, fractions, and decimal problems.

Compute and solve problems with whole numbers, fractions, and decimals.

Example Questions

Whole numbers, fractions, and decimal problems.

Question:

Simplify.

$$12 + 15 \div 3 \times 6 - 4$$

- A 18
- B 22
- C 38
- D 50

6 Squares, square roots, cubes, and cube roots

Calculate and compute with squares, square roots, cubes, and cube roots of numbers.

Example Questions

Squares, square roots, cubes, and cube roots**Question:**

Add.

$$\sqrt[3]{7} + \sqrt{7}$$

- A $4\sqrt{7}$
- B $\sqrt[3]{14}$
- C $4\sqrt{14}$
- D $\sqrt[3]{49}$

7 Undefined expressions

Know that expressions with a denominator of zero are "undefined" and have no solution.

Identify "undefined" numerical expressions which have no solution, including:

- a denominator of zero
- square roots of negative numbers

Example Questions

Undefined expressions

Question:

Which expression is undefined in the set of real numbers?

- A $\sqrt{-4}$
- B $\frac{0}{-4}$
- C 0^4
- D -4×0

8 Unit rates

Find unit rates.

For example:

- miles per hour
- dollars per pound

Example Questions

Unit rates

A store charges \$6.96 for a case of mineral water.

- Each case contains 2 boxes of mineral water.
- Each box contains 4 bottles of mineral water.

Question:

What is the cost of each bottle of mineral water?

- A \$0.87
- B \$1.16
- C \$1.74
- D \$3.48

9 **Objects at scale**

Use scale factors to convert dimensions between scale drawings and actual objects.

For example, you might be presented with an image of the dimensions of a room. The image may use 1 inch to represent 1 foot of real space in the room.

Example Questions

Objects at scale**Question:**

A scale drawing of a house uses a scale of 0.5 inches = 2 feet. What is the length, in inches, of a line on the scale drawing that represents an actual length of 5 feet?

- A 1.25
- B 2.5
- C 10
- D 20

10 Multiple-step problems that use ratios, proportions, and percents

Solve multiple-step problems that use ratios, proportions, and percentages.

Examples of multi-step problems include:

- Simple interest
- Percent increase and decrease
- Gratuities
- Commissions

Example Questions

Multiple-step problems that use ratios, proportions, and percents

Question:

The price of Veronica's meal before tax and tip was \$11.92. Veronica paid 8% tax, then added a 15% tip to the total. To the nearest cent, how much did Veronica pay for her meal?

- A \$12.87
- B \$13.71
- C \$14.66
- D \$14.80





Geometry

1 Side lengths of shapes when given the area or perimeter

Find the side lengths of triangles, rectangles, and polygons when given the area or perimeter.

Remember, you will be provided with the math formulas.

Example Questions

Side lengths of shapes when given the area or perimeter

Question:

A rectangle has an area of 54 square inches and a length of 6 inches. What is the width, in inches, of the rectangle?

- A 9
- B 21
- C 24
- D 48

2 Area and perimeter of two-dimensional shapes

Find the area and perimeter of two-dimensional shapes, including triangles, rectangles, polygons, and composite shapes.

Remember, you will be provided with the math formulas.

Example Questions

Area and perimeter of two-dimensional shapes

The Wilson family's back yard is a rectangular plot that has a length of 100 feet and a width of 80 feet. The family planted a garden with a length and width of 60 feet. The family planted a lawn in the remaining area of the back yard, as shown.

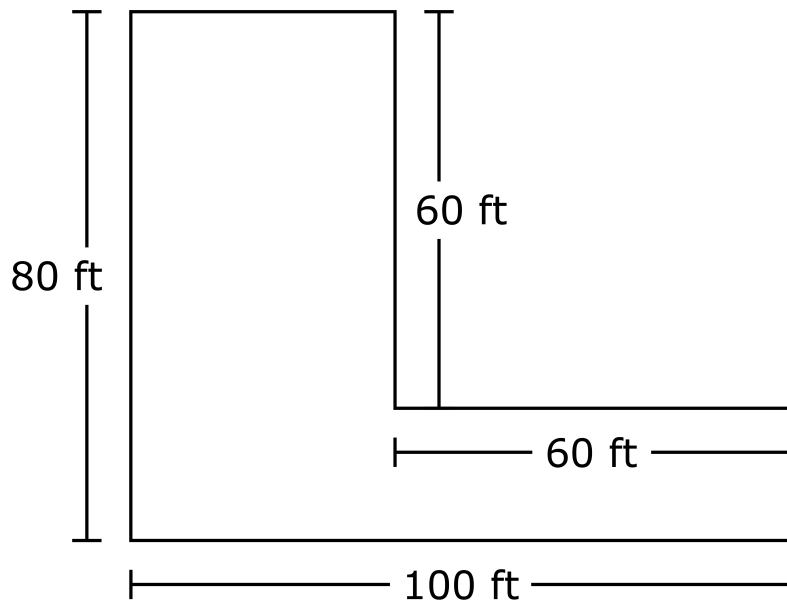

Question:

What is the area, in square feet, of the lawn in the Wilson family's back yard?

- A 4,400
- B 5,200
- C 5,600
- D 8,000

3 Area, circumference, radius, and diameter of a circle

Find the area and circumference of a circle. Find the radius or diameter of a circle when given the area or circumference.

Remember, you will be provided with the math formulas.

Example Questions

Area, circumference, radius, and diameter of a circle

Greg installed a circular drain that has a diameter of 4.8 inches.

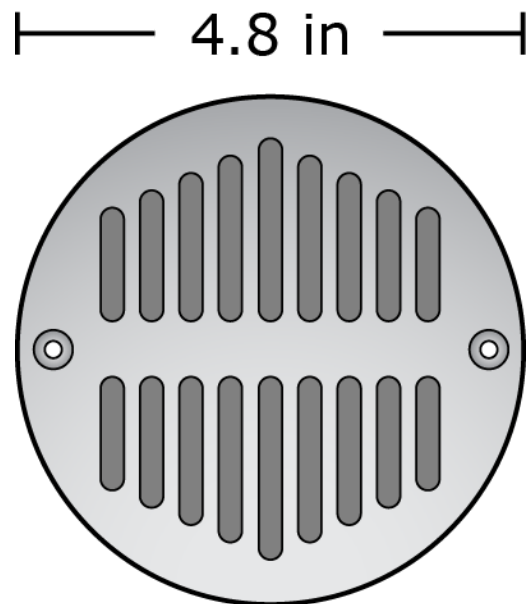

Question:

To the nearest tenth of an inch, what is circumference of the drain?

- A 7.5
- B 15.1
- C 18.1
- D 30.1

4 Pythagorean theorem

Use the Pythagorean theorem $a^2 + b^2 = c^2$ to find a side length in a right triangle.

Example Questions**Pythagorean theorem**

The foundation of a building is in the shape of a rectangle, with a length of 20 meters (m) and a width of 18 m.

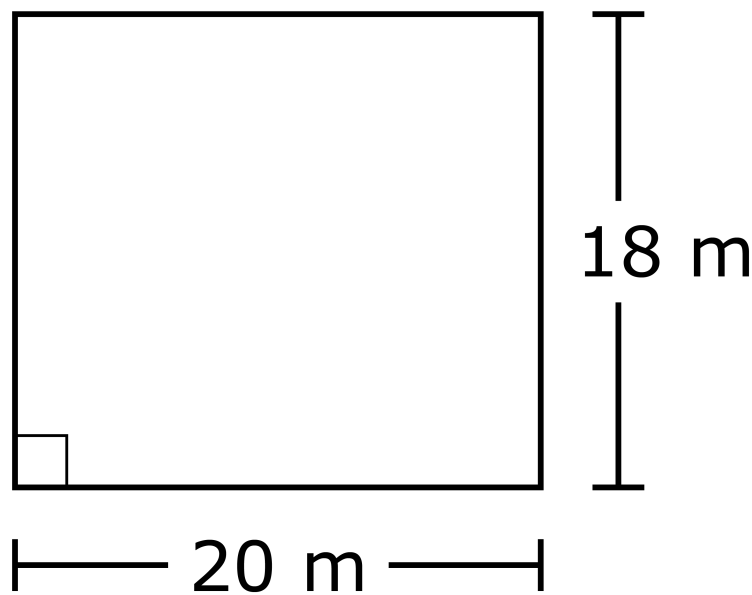
**Question:**

To the nearest meter, what is the distance from the top left corner of the foundation to the bottom right corner?

- A 19
- B 27
- C 36
- D 38

5 Volume and surface area of three-dimensional shapes

Find the volume and surface area of three-dimensional shapes, including rectangular and right prisms, cylinders, and right pyramids. Find the side lengths, radius, or diameter of a three-dimensional figure when given the volume or surface area.

Remember, you will be provided with the math formulas.

Example Questions**Volume and surface area of three-dimensional shapes**

A sphere has a radius of 7.5 centimeters (cm).

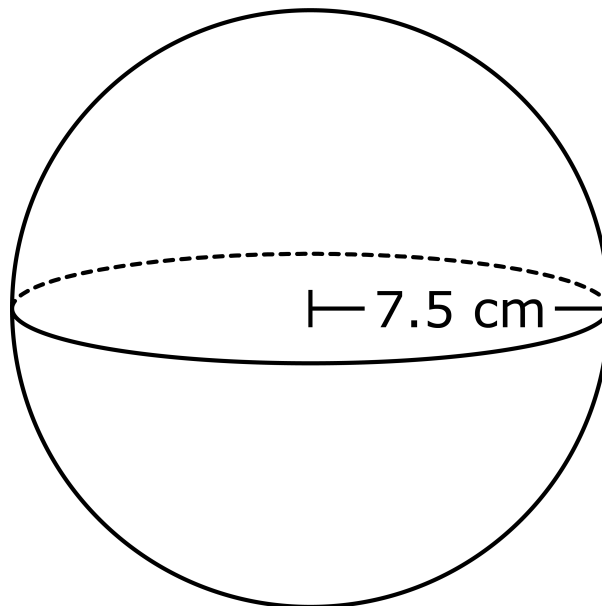
**Question:**

To the nearest cubic centimeter, what is the volume of the sphere?

- A 236
- B 1,325
- C 1,766
- D 14,130

6 Graphical data including graphs, tables, and more

Construct and explain data from bar graphs, circle graphs, dot plots, histograms, box plots, tables, scatter plots, and line graphs.

Example Questions**Graphical data including graphs, tables, and more**

The line graph shows the monthly payroll at a large construction company.

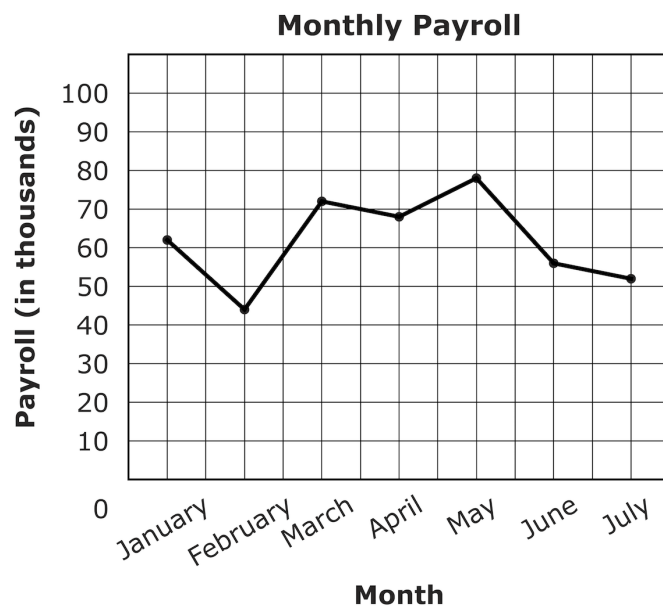
**Question:**

In which month did the monthly payroll decrease the most?

- A February
- B March
- C June
- D July

7 Mean, median, mode, and range

Find the mean, median, mode, and range of a number set. Find a missing value when given an average.

Example Questions

Mean, median, mode, and range

The manager of an apartment complex ordered the air conditioners in the apartments to be replaced. The list shows how many years each air conditioner had been in service.

12.2, 13.7, 11.9, 13.4, 11.9, 12.3, 12.9, 11.8, 13.3, 13.6

Question:

What is the median number of years that an air conditioner had been in service?

- A 11.9
- B 12.1
- C 12.6
- D 12.7

8 Counting techniques

Use counting techniques to solve math problems. For example, count how many different ways objects can be ordered, arranged, or combined.

Example Questions

Counting techniques

Question:

A restaurant serves custom-made omelets, where guests select meat, cheese, and vegetables to be added to their omelet. There are 6 vegetables available, and guests may select any 2 vegetables for their omelet. How many different combinations of 2 vegetables are possible?

A 12

B 15

C 30

D 36

9 Probability of an event

Find the probability of one or more events happening.

For example, what is the probability of drawing a jack or a king randomly from a deck of cards?

Example Questions

Probability of an event

Question:

In a shipment of toys from a manufacturer, the probability that a toy is defective is $\frac{1}{50}$. If Marie selects 2 toys from a shipment, what is the probability that both toys are defective?

A $\frac{1}{25}$

B $\frac{1}{50}$

C $\frac{1}{100}$

D $\frac{1}{2,500}$



Basic Algebra

1 Add, subtract, multiply, and factor linear expressions

Simplify linear expressions by adding, subtracting, multiplying, expanding, and factoring.

For example:

- Expand $4(7x - 2)$
- Factor $4x + 8$

Example Questions

Add, subtract, multiply, and factor linear expressions

Question:

Subtract.

$$(3x - 4y) - (4x - 3y)$$

- A $-x - y$
- B $7x - y$
- C $-x - 7y$
- D $7x - 7y$

2 Evaluate algebraic expressions

Evaluate algebraic expressions by substituting (replacing) variables with numbers.

Example Questions

Evaluate algebraic expressions

Question:

A painter uses the expression $35h + 30c$ to determine how much he charges a customer for a job that takes h hours and c cans of paint. His last job required 3 cans of paint and took 15 hours to complete. How much did the painter charge?

A \$540

B \$555

C \$615

D \$630

3 Algebraic expressions -- creation

Create algebraic expressions to represent problem situations or word-to-symbol translations.

Example Questions

Algebraic expressions -- creation

Question:

In a science experiment, the initial temperature was 55 degrees Fahrenheit, and each hour after, the temperature dropped by 4 degrees. Which expression represents the temperature, in degrees Fahrenheit, after t hours?

- A $55 - 4t$
- B $55 + 4t$
- C $4t + 55$
- D $4t - 55$

4 Add, subtract, multiply, divide, and factor polynomials

Add, subtract, multiply, divide, and factor polynomials.

For example:

- $(x + 8)(x + 4)$
- Factor $3x^2 - 10x - 8$

Example Questions

Add, subtract, multiply, divide, and factor polynomials

Question:

Multiply.

$$(2x - y)(3x + y)$$

- A** $6x^2 - xy - y^2$
- B** $5x^2 - xy - y^2$
- C** $6x^2 - xy - 2y^2$
- D** $5x^2 - xy - 2y^2$

5 Create polynomials from written descriptions

Create polynomials to represent problem situations or word-to-symbol translations.

For example, a triangle has three sides with the following lengths:

$$2x + 1 \text{ units}, 3x + 5 \text{ units}, \text{ and } 4x - 1 \text{ units}$$

Write an algebraic expression for the perimeter of the triangle in units.

Example Questions

Create polynomials from written descriptions**Question:**

A rental company carries tables that seat 2, 4, or 8 people. For a wedding, a customer orders x tables that seat 2 people, y tables that seat 4 people, and z tables that seat 8 people. Which expression represents the number of people who could be seated at the tables that the customer orders?

- A $2x(4y)(8z)$
- B $2x + 4y + 8z$
- C $(2 + 4 + 8)(xyz)$
- D $(2 + 4 + 8)(x + y + z)$

6 Add, subtract, multiply and divide rational expressions

Add, subtract, multiply and divide rational expressions.

Example Questions

Add, subtract, multiply and divide rational expressions

Question:

Add.

$$\frac{3}{x} + \frac{x}{x+2}$$

A $\frac{3+x}{2x+2}$

B $\frac{x+5}{2x+2}$

C $\frac{x^2+3x+2}{x(x+2)}$

D $\frac{x^2+3x+6}{x(x+2)}$

7 Write an expression from a written description

Write an expression from a written description.

Example Questions

Write an expression from a written description

A written description of a mathematical expression is shown.

the quotient of the sum of 4 and 2 times a number, and the difference of 6 less than 3 times the same number

Question:

Which expression matches the written description?

A $\frac{2x + 4}{3x - 6}$

B $\frac{2x + 4}{6 - 3x}$

C $(2x + 4)(3x - 6)$

D $(2x + 4)(6 - 3x)$

8 Use linear equations to solve real-world problems

Use linear equations to solve real-world problems. For example, calculate the fuel efficiency of a car at different speeds.

Example Questions

Use linear equations to solve real-world problems

Question:

Lucy is shipping 5 boxes that all weigh the same, and 1 envelope that weighs 7.5 pounds. The total weight of the shipment is 65 pounds. What is the weight, in pounds, of each box?

- A 5.5
- B 11.5
- C 14.5
- D 20.5

9 Solve a system of two linear equations

Solve a system of linear equations and real-world problems that involve them.

Common techniques include graphing, substitution, or addition to compute a system of two linear equations.

Example Questions

Solve a system of two linear equations

A system of equations is shown.

$$4x + 3y = 8$$

$$4x - 3y = -16$$

Question:

What is the value of x ?

A -3

B -1

C 1

D 4

10 Solve inequalities and graph the answer on a number line

Solve inequalities and real-world problems that involve them, and graph the solutions.

Example Questions

Solve inequalities and graph the answer on a number line**Question:**

Isabella saved \$15,000 and bought a car that cost \$12,700. The insurance for the car will cost \$600 per year. How many full years will Isabella be able to pay for car insurance with her remaining savings?

- A 3
- B 4
- C 21
- D 25

11 Quadratic equations with one variable

Solve quadratic equations with one variable.

For example, $3x^2 + 2x - 8 = 0$.

Example Questions

Quadratic equations with one variable

Question:

Solve.

$$4x^2 - x - 5 = 0$$

- A $x = -1$ and $x = \frac{5}{4}$
- B $x = \frac{4}{5}$ and $x = 1$
- C $x = -1$ and $x = \frac{4}{5}$
- D $x = 1$ and $x = \frac{5}{4}$



Graphs and Functions

1 Locate points and graph equations

Locate points and graph linear equations in a coordinate plane.

Example Questions

Locate points and graph equations

Points J , K , and L are plotted on a coordinate grid.

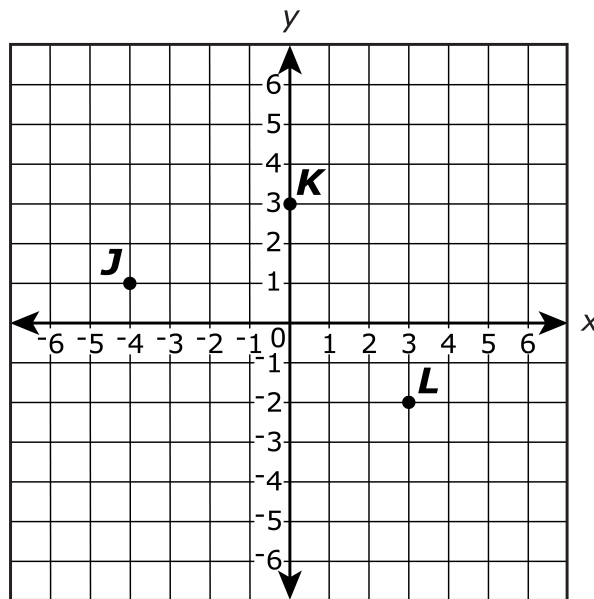

Question:

What are the coordinates of the points on the coordinate grid?

- A J (1, -4); K (3, 0); L (-2, 3)
- B J (-4, 1); K (0, 3); L (3, -2)
- C J (-4, 1); K (0, 3); L (-2, 3)
- D J (-4, 1); K (3, 0); L (3, -2)

2 Slope of a line from a graph, equation, or table

Find the slope of a line from a graph, equation, or table.

Example Questions

Slope of a line from a graph, equation, or table**Question:**

What is the slope of the line represented by the equation $3x + 4y = 8$?

A $-\frac{4}{3}$

B $-\frac{3}{4}$

C $\frac{3}{4}$

D $\frac{4}{3}$

3 Proportional relationships for equations and graphs

Determine whether an equation and a graph show the same proportional relationship.

Example Questions

Proportional relationships for equations and graphs

Question:

Chelsea designs beaded bracelets. The equation $P = 7 + 0.05b$ can be used to find the price, P , of a bracelet that has b beads. What does the number 0.05 in the equation represent?

- A the price of each bead
- B the price of each bracelet
- C the number of bracelets made
- D the number of beads in a bracelet

4 Features of graphs and tables for linear and nonlinear relationships

Identify features of graphs and tables for linear and nonlinear relationships.

For example, using the rise/run to determine slope, coordinates of points, and x/y intercept.

Example Questions

Features of graphs and tables for linear and nonlinear relationships

Question:

Kirsten walks up 6 flights of stairs to her office each morning as part of her exercise routine. She walks the first 3 flights, rests for 30 seconds, walks the next 2 flights at the same rate of speed as she walked the first 3 flights, rests again for 30 seconds, and then walks the last flight of stairs at the same rate. Which graph represents Kirsten walking up the stairs?

A

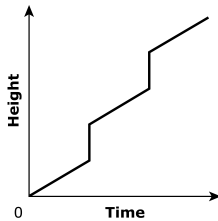

B

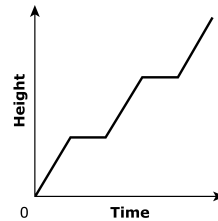

C

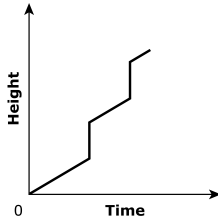

D

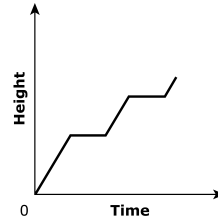

5 Slope and a point on a line

Find the equation of a line when given the slope and a point on the line.

Example Questions

Slope and a point on a line**Question:**

What is the equation of the line that has a slope of -7 and passes through the point $(4, 8)$?

- A $x + 7y = 60$
- B $7x + y = 36$
- C $x - 7y = -52$
- D $7x - y = 20$

6 Equation of a line from two points

Find the equation of a line from two points on the line.

Example Questions

Equation of a line from two points**Question:**

What is the equation of the line that passes through the points (-3, -2) and (1, 6)?

- A $y = 2x + 4$
- B $y = -2x + 8$
- C $y = \frac{1}{2}x - \frac{1}{2}$
- D $y = \frac{1}{2}x - \frac{11}{2}$

7 Use slope of a line

Use the slope of a line to solve problems, for example identify whether lines are parallel or perpendicular.

Example Questions

Use slope of a line**Question:**

What is the slope of a line that is perpendicular to $5x - 2y = 1$?

(A) $\frac{-5}{2}$

(B) $\frac{-2}{5}$

(C) $\frac{2}{5}$

(D) $\frac{5}{2}$

8 Functions shown in different ways

Compare functions that are shown in different ways, such as tables, graphs, equations and written descriptions.

Example Questions

Functions shown in different ways

Question:

Tim is looking at two websites that allow customers to print their own designs on T-shirts. One website charges \$24 per T-shirt plus \$8 shipping. The other website uses the equation $C = 22n + 12$ to find the total cost, C , of printing n T-shirts. What is the difference in the cost of each website if Tim orders 10 T-shirts?

- A \$2
- B \$16
- C \$20
- D \$24

9 Functions in tables and graphs

Recognize a function in a table or graph by determining whether or not there is only one output value for each input value.

Example Questions**Functions in tables and graphs****Question:**

Which table represents a function?

A

x	y
0	-4
0	4
2	-3
2	3

B

x	y
-5	4
5	-1
5	3
1	4

C

x	y
-5	-4
-4	-4
-3	-2
0	-1

D

x	y
-2	1
-2	-3
2	1
2	-3

10 Evaluating functions

Evaluate a function.

For example:

$$f(x) = x^2 - 3x; \text{ find } f(-8)$$

Example Questions

Evaluating functions

Question:

What is the value of $f(x) = 3x^2 + 4$ when $x = -3$?

A -77

B -23

C 31

D 85

