

Lesson 1432: Common-Emitter Amplifier Characteristics

Experiment 2: AC and DC Transistor Gain

For more courses visit www.cie-wc.edu

Objectives

1. To show how to determine the AC and DC current gain values of a transistor from its characteristics curves
2. To give more experience plotting characteristic curves
3. To demonstrate the characteristics among various transistors of the same type can vary considerably

Introduction

- Previously, you learned to plot the common-emitter characteristics of a typical NPN transistor.
- As part of this experiment, you will plot two other sets of curves, to show the characteristics vary among transistors of the same type

- You will also learn to determine transistor gain by merely picking out appropriate points on a graph and doing some simple calculations.
- The D-C current gain of a transistor is simply the collector current divided by the base current.

- $$\beta_{D-C} = \frac{I_C}{I_B}$$

- The Greek letter β (Beta) represents the current gain which is also represented as h_{FE}

- The current gain can be determined by picking V_{CE} and I_B values from the characteristic curves and then reading the collector current
- Example: Look at the following (A-C and D-C Current Gain Calculation Graph); when $V_{CE} = 5.5 \text{ V}$ and $I_B = 30 \text{ }\mu\text{A}$, the collector current is 6 mA. The D-C beta

is:
$$\beta_{D-C} = \frac{6 \times 10^{-3}}{30 \times 10^{-6}} = 200$$

A-C and D-C Current Gain Calc. Graph

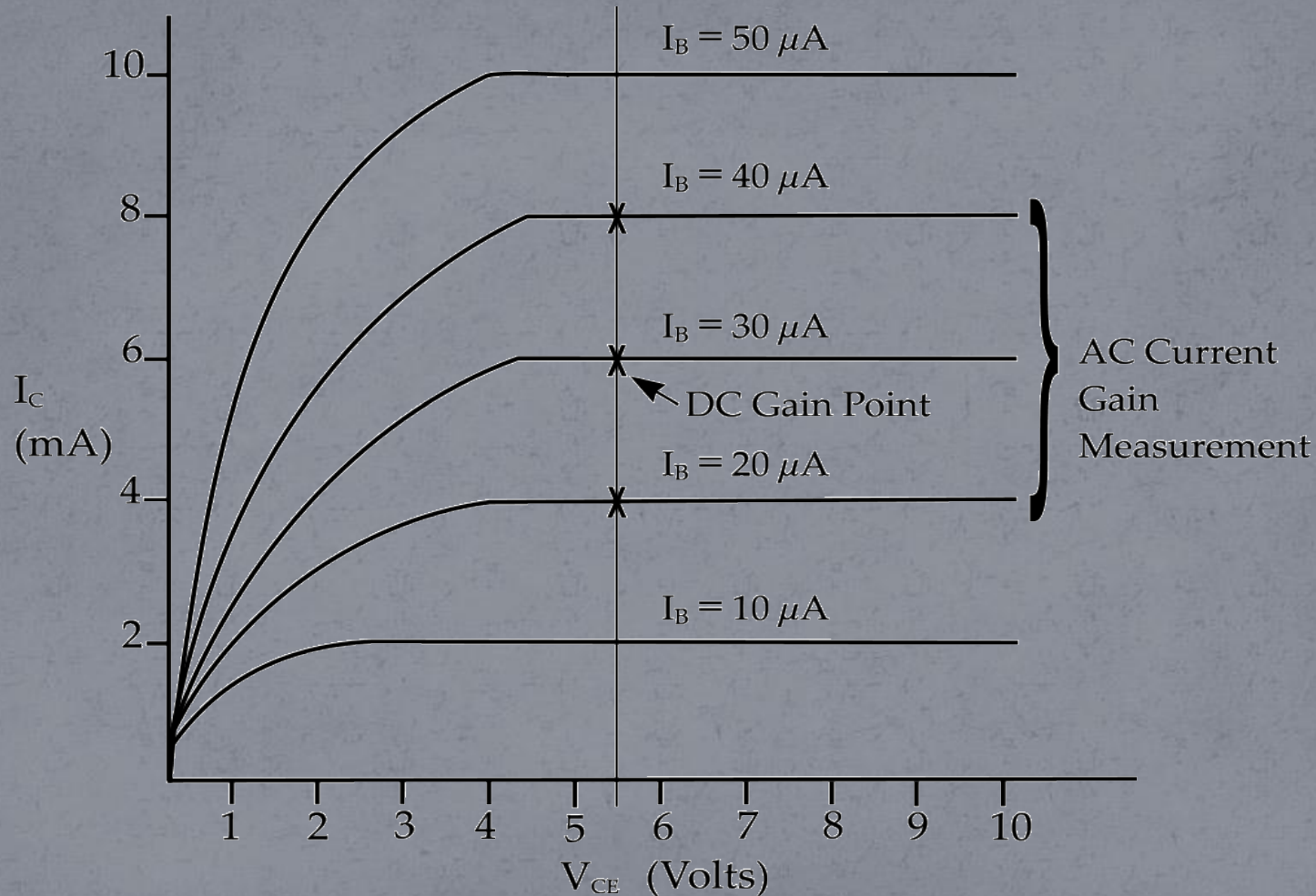

Common-emitter A-C & D-C current-gain calculations characteristics curve graph

- Note: The actual values of β will depend somewhat on the point on the graph. The curves shown in this case are for an ideal transistor, so that almost any point we pick will give us the same beta
 - Expect some “real world” variations when completing the experiment, since practical transistors are always less than perfect

- The a-c current gain calculation differs from the d-c current gain calculation.
 - The a-c gain is calculated in terms of specific increments of base current
 - This technique give a more accurate picture of how a transistor reacts to a-c signals

- Use the previous graph (A-C and D-C Current Gain Calculation Graph) to determine the A-C current gain
 - Determine how the collector current changes when the base current is varied between $20\ \mu\text{A}$ and $40\ \mu\text{A}$ with V_{CE} held constant at $5\ \text{V}$
 - Use the following formula to determine the A-C Current Gain.
 - $\beta_{A-C} = \frac{\Delta I_C}{\Delta I_B}$ The Δ (delta) symbol means “change in”

- Using the values from our current a-c example, we have: $\beta_{A-C} = \frac{(8 \times 10^{-3}) - (4 \times 10^{-3})}{(40 \times 10^{-6}) - (20 \times 10^{-6})} = \frac{4 \times 10^{-3}}{200 \times 10^{-6}} = 200$
- The A-C current is sometimes call h_{fe} & is the same as the D-C gain in this case, since we are using ideal characteristics.
 - We usually expect a considerable difference in values with practical transistors, but the A-C and D-C values may be the same

- Please note! The current gains we have been discussing are for the *transistor* itself, not the amplifier circuit.
 - Biasing networks, input, output and loading will usually decrease the current gain of a practical CE *amplifier*
- You will plot the characteristics of two more transistors, then compare the results with the curves you obtained from the first experiment's transistor

- Finally, you will calculate the AC and DC gains for all three transistors.
- You should see that generally speaking, no two transistors are entirely alike.
 - Matched sets are available for special purchase

Required Parts

- 1 330 Ω , 1/2 Watt Resistor (orange, orange, brown)
- 1 100 k Ω , 1/2 Watt Resistor (brown, black, yellow)
- 1 1 k Ω potentiometer (on trainer)
- 1 100 k Ω potentiometer (on trainer)
- 1 MPSA20 NPN transistor (or similar)

Note: Your results may be considerably different than those found by CIE. This is because the current gain for each transistor may be quite different . *Do not be surprised if your results are not close to ours.*

Procedure

- The circuit for this experiment (Exp. 2) is the same circuit as you built in Exp. 1.
- You will be measuring the characteristics of two more MPSA20 transistors and then compare the data with the characteristics of the MPSA20 transistor used in the first experiment.
(1432 Exp. 1)

1. Locate the MPSA20 transistor used in 1432 Exp. 1 and set it aside for future use. Mark this transistor as Q₁
 - a) Find two more MPSA20 transistors and mark them Q₂ and Q₃, so you will be able to identify them later
2. Construct the circuit on the following slide and use the transistor that you marked as Q₂
 - a) Connect the transistors properly

1432 Exp. 2, Q2 Schematic Diagram

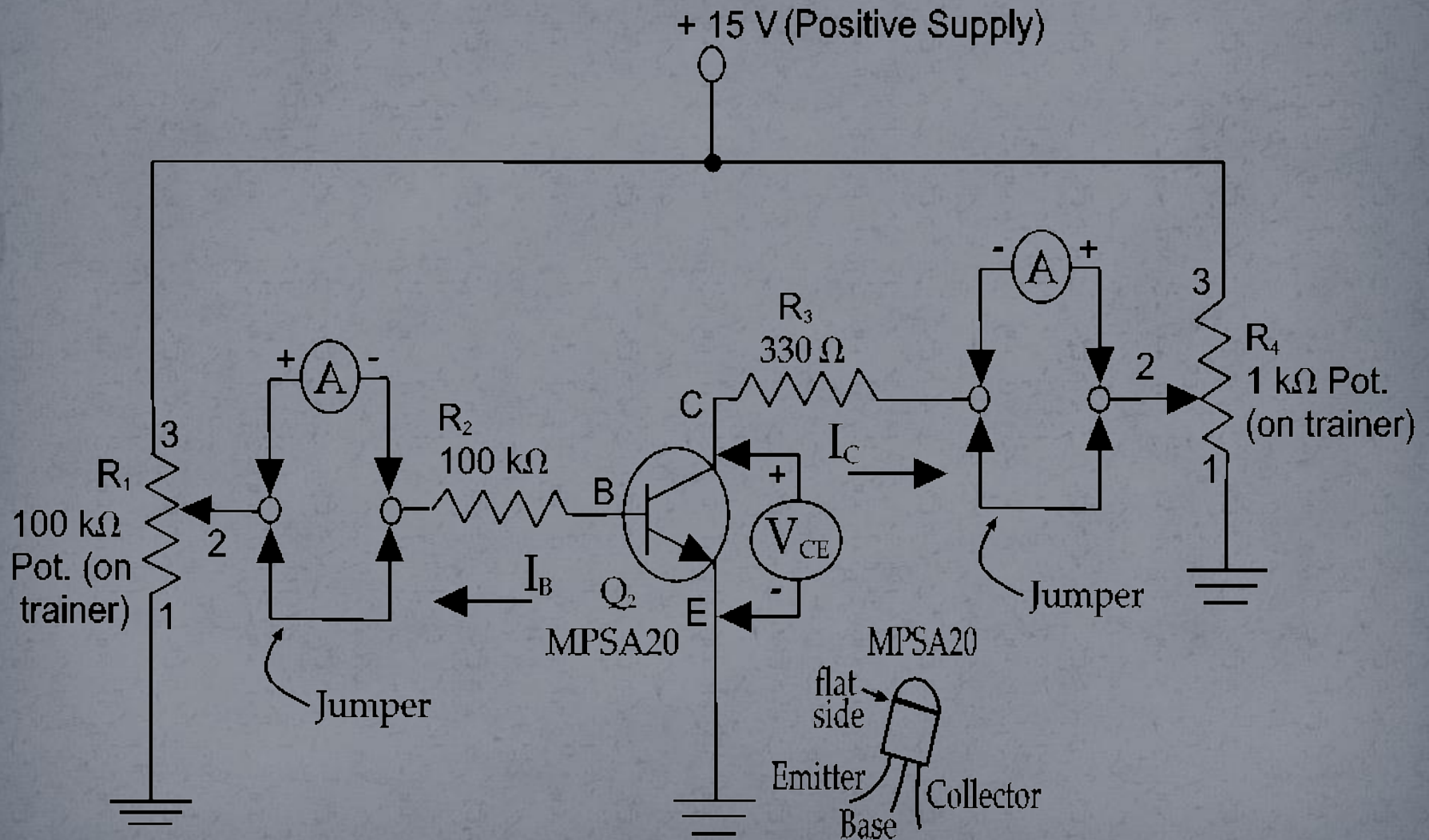

1432 Exp. 2, Q3 Pictorial Diagram

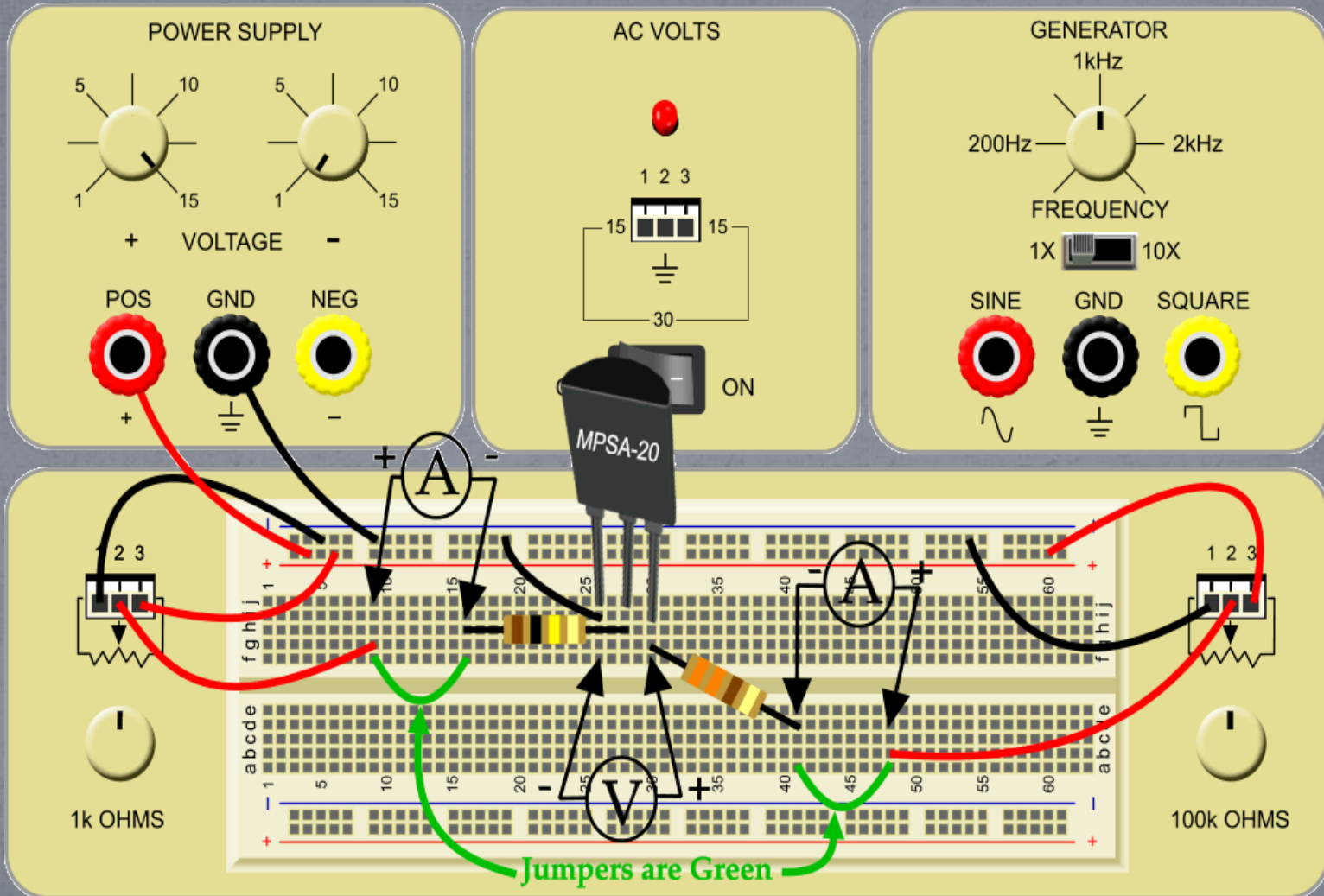

1. Transistors wired incorrectly is a common mistake
3. Measure the collector current values for Q₂ using the given base currents and VCE setting
 - a) Mark the measured values in the data table for transistors Q₂ characteristics on the next slide

Data Table for Q_2 & Q_3 Characteristics

V_{CE}	$I_C = (Q_2)$ in mA			$I_C = (Q_3)$ in mA		
	$I_B = 10 \mu A$	$I_B = 20 \mu A$	$I_B = 30 \mu A$	$I_B = 10 \mu A$	$I_B = 20 \mu A$	$I_B = 30 \mu A$
0 V						
1 V						
2 V						
3 V						
4 V						
5 V						
6 V						
7 V						
8 V						
9 V						
10 V						

4. Complete all the readings for Q₂ and then replace the transistor with Q₃ as demonstrated in the following schematic diagram
 - a) Repeat the measurements for Q₃ and then turn off the power supply.

1432 Exp. 2, Q3 Schematic Diagram

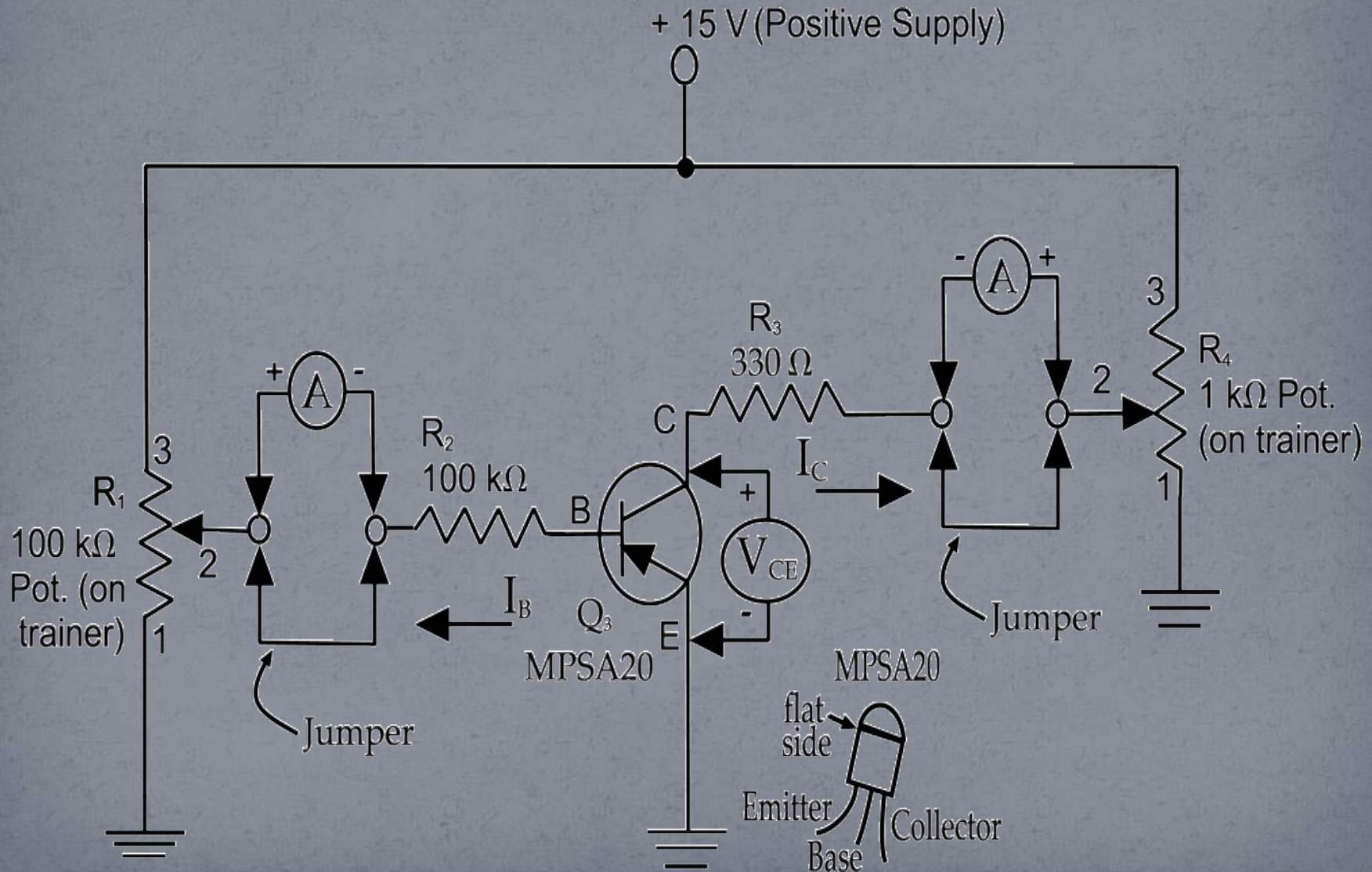

1432 Exp. 2, Q3 Pictorial Diagram

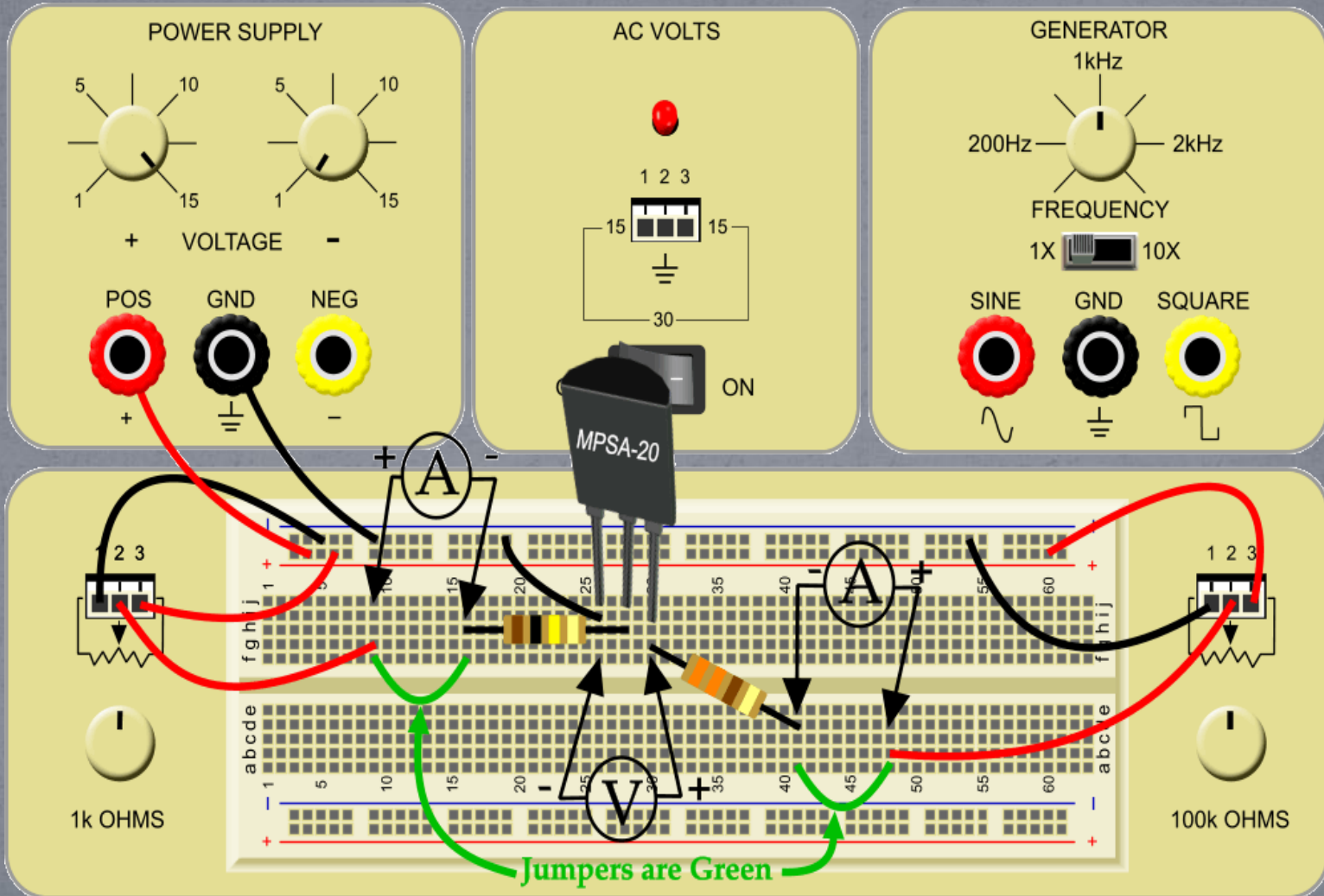

5. Plot the data points for Q₂ on the Q₂ Characteristic Curve Graph.
 - a) Plot the data points for Q₂ on the Q₂ Characteristic Curve Graph.
 - b) Connect each set of data points and draw smooth lines for each set after all the data has been plotted.

Graph for Q₂ Characteristics

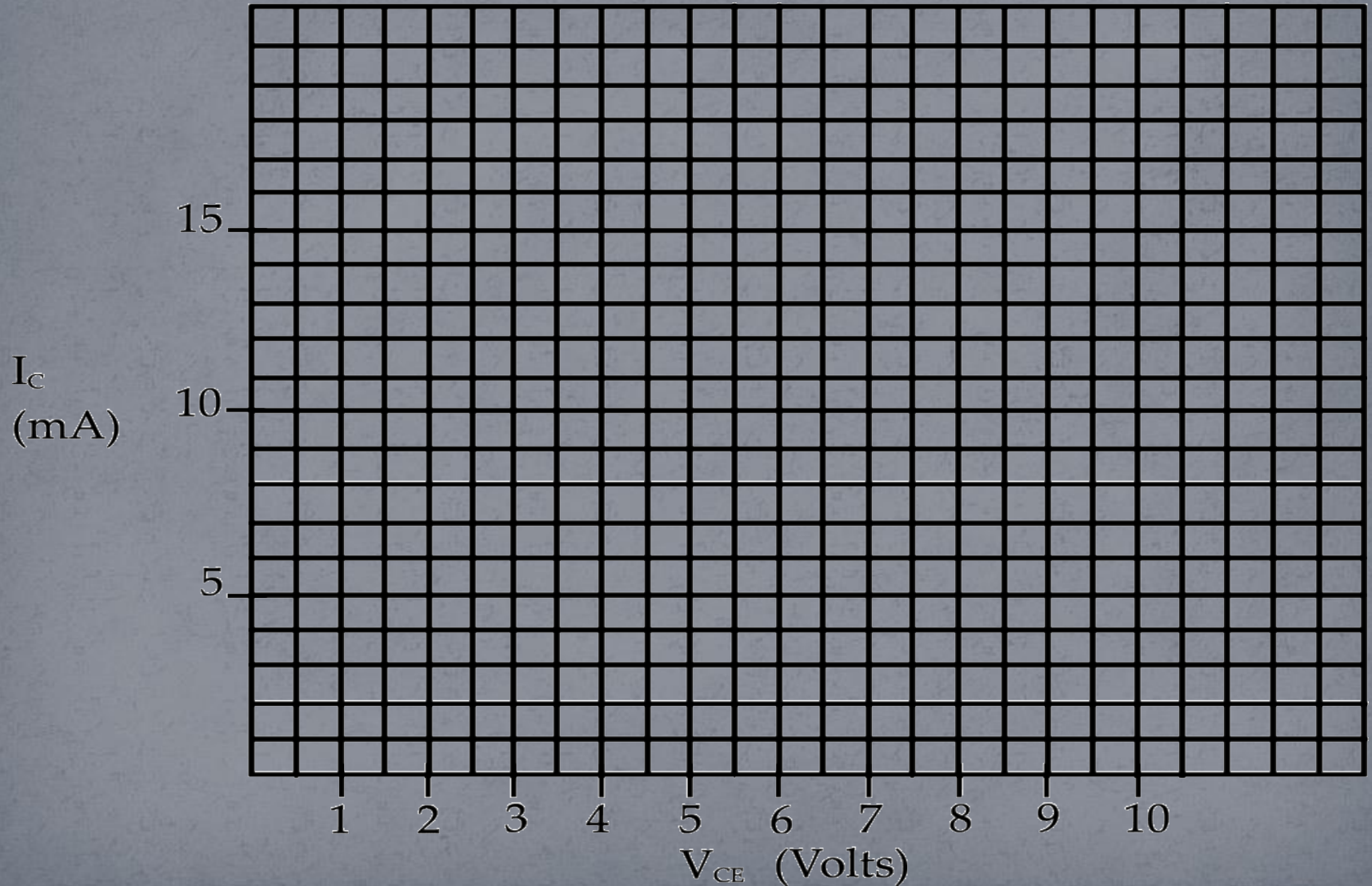

Graph for Q₃ Characteristics

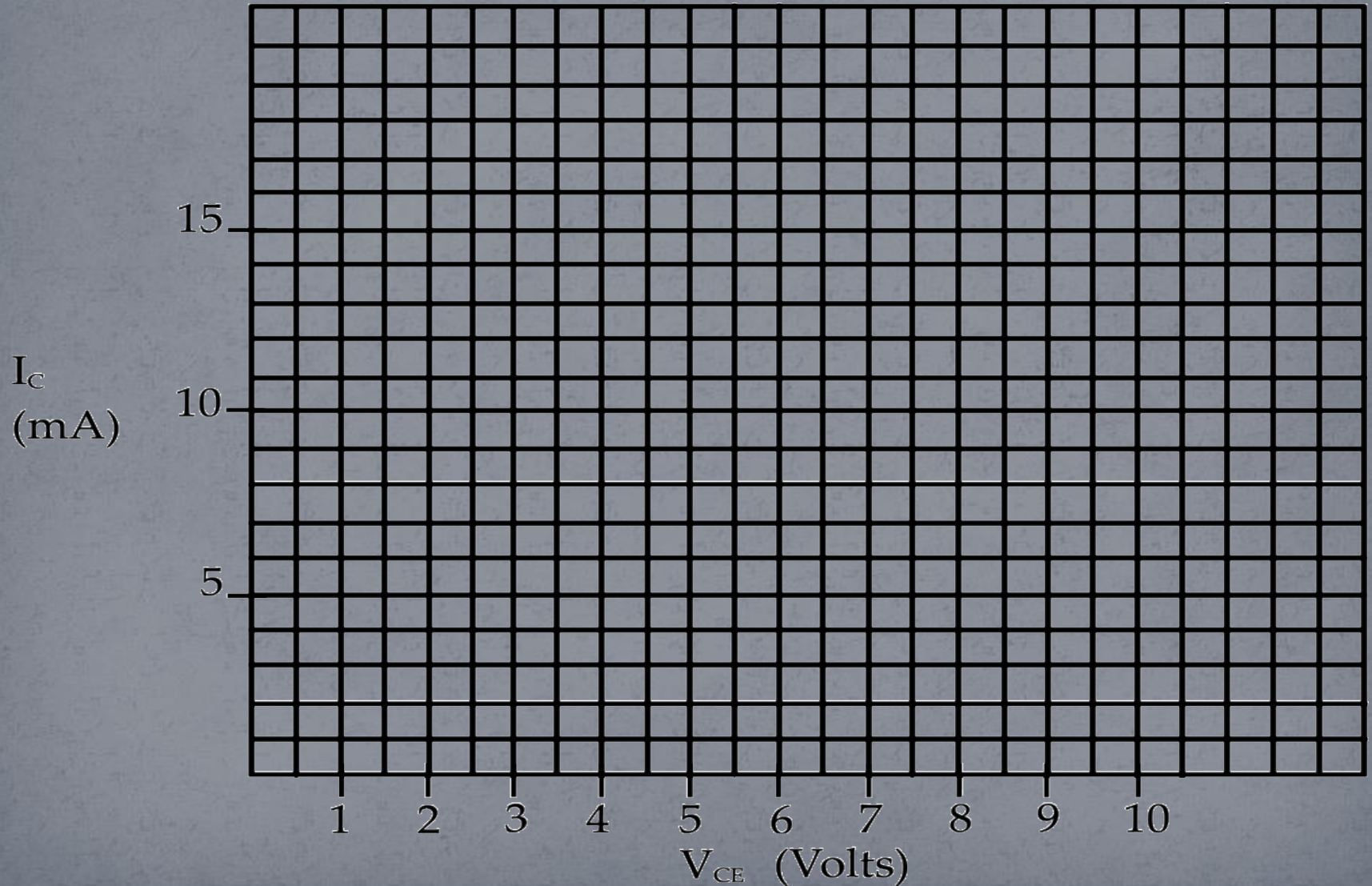

6. Compare your curves with the one you developed from the first experiment. Are the three family of curves identical? This means the three family of curves (do)(don't) have identical characteristics.
7. You can now see how the DC and AC gains differ, since you have completed the sets/families of characteristic curves for the three transistors.

- a) Now, based on the three transistor curves, determine the value of I_C when $I_B = 20 \mu\text{A}$ and $V_{CE} = 5 \text{ V}$.
 - b) Record each value of I_C in line 1 of the Data Table for Current Gain Calculations, under the appropriate heading
8. We can calculate the DC gain, with I_B equaling $20 \mu\text{A}$.

a) Use the following formula to calculate for β_{DC} for each transistor

1.
$$\beta_{DC} = \frac{I_C}{20 \times 10^{-6}}$$

9. Calculate each DC current gain value, and enter it in line 2 of the Current Gain Calculations Data Table

10. The AC current gain is calculated by finding out how much the collector current varies when the base current changes by a certain amount

- a) We will use a base current of $\pm 10 \mu A$ for this experiment. Use the graphs for all three transistors as you did previously and record the values in line 3 of the Current Gain Calculations Data Table
- ii. Now find the value of I_C for all three transistors at a base current of $30 \mu A$ and a V_{CE} of 5 V.
 - a) Record the value for each transistor in line 4 of the data table

12. The AC current gain of each transistor may be found using the following formula:

$$\beta_{AC} = \frac{\Delta I_C}{\Delta I_B}$$

- a) In this case, ΔI_B is $20 \mu\text{A}$ ($30 - 10 \mu\text{A}$), while ΔI_C is the difference between line 4 and line 3 of the Current Gain Calculation Data Table
- b) Record the results of the calculations in the Current Gain Calculation Data Table

CIE Results

- Our results can be seen on the following four slides. Considerable variation can be expected due to the wide variations of transistor gain.
- Do not let the variation worry you as long as you show the same general pattern we do.

1432, Exp. 2, Data table Results

V_{CE}	$I_c = (Q_2)$ in mA			$I_c = (Q_3)$ in mA		
	$I_B = 10 \mu A$	$I_B = 20 \mu A$	$I_B = 30 \mu A$	$I_B = 10 \mu A$	$I_B = 20 \mu A$	$I_B = 30 \mu A$
0 V	0	.05	.07	0	.06	.07
1 V	1.35	2.65	4.05	1.3	2.72	4.17
2 V	1.35	2.66	4.07	1.32	2.74	4.21
3 V	1.37	2.68	4.1	1.33	2.77	4.25
4 V	1.38	2.7	4.15	1.34	2.79	4.27
5 V	1.4	2.72	4.2	1.35	2.8	4.3
6 V	1.4	2.74	4.25	1.36	2.83	4.33
7 V	1.41	2.77	4.27	1.37	2.85	4.37
8 V	1.42	2.8	4.3	1.38	2.86	4.4
9 V	1.43	2.81	4.32	1.39	2.88	4.44
10 V	1.44	2.83	4.35	1.4	2.9	4.47

1432, Exp. 1, Q1, Characteristic Curves

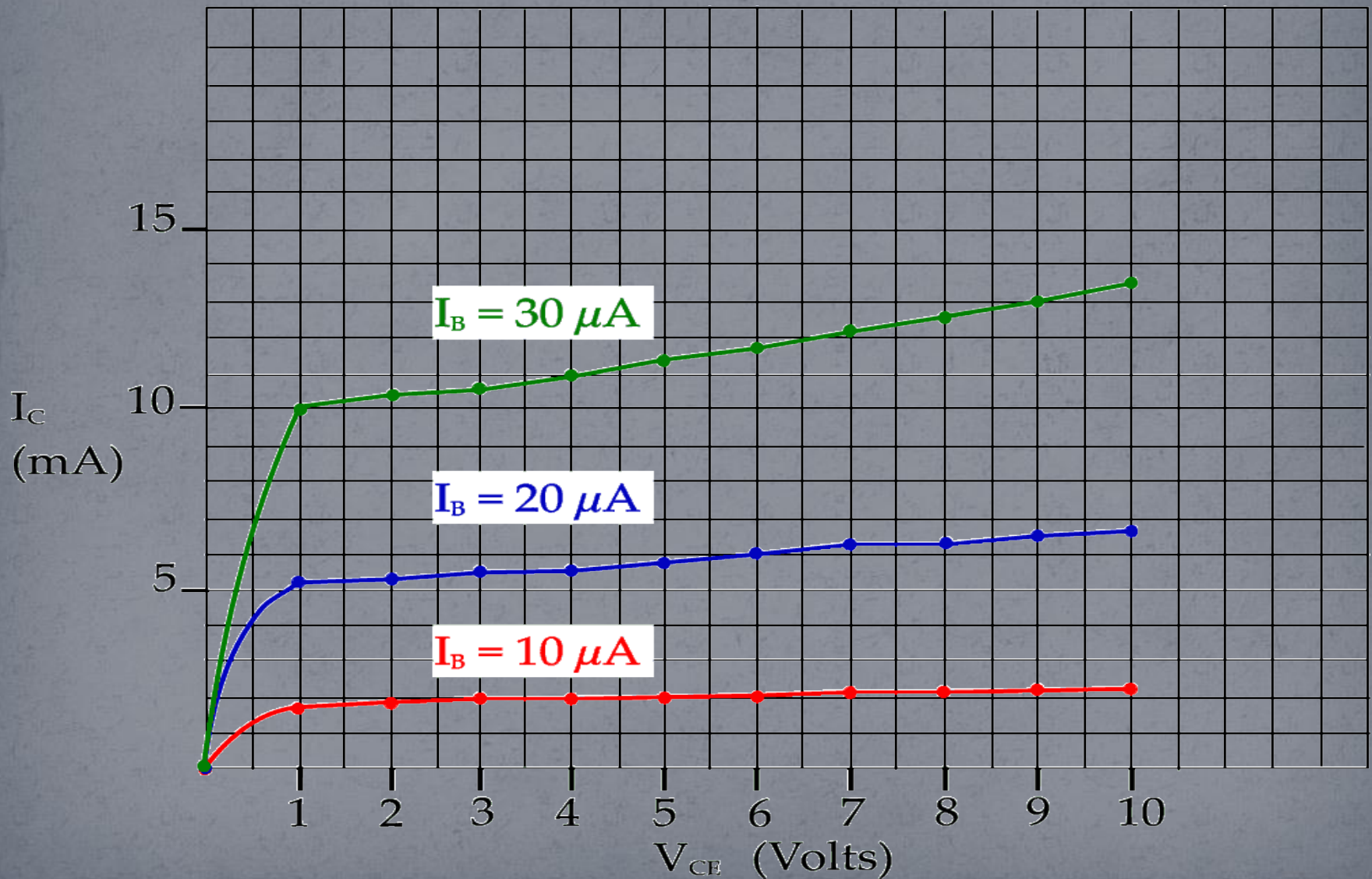

1432, Exp. 2, Q2, Characteristic Curves

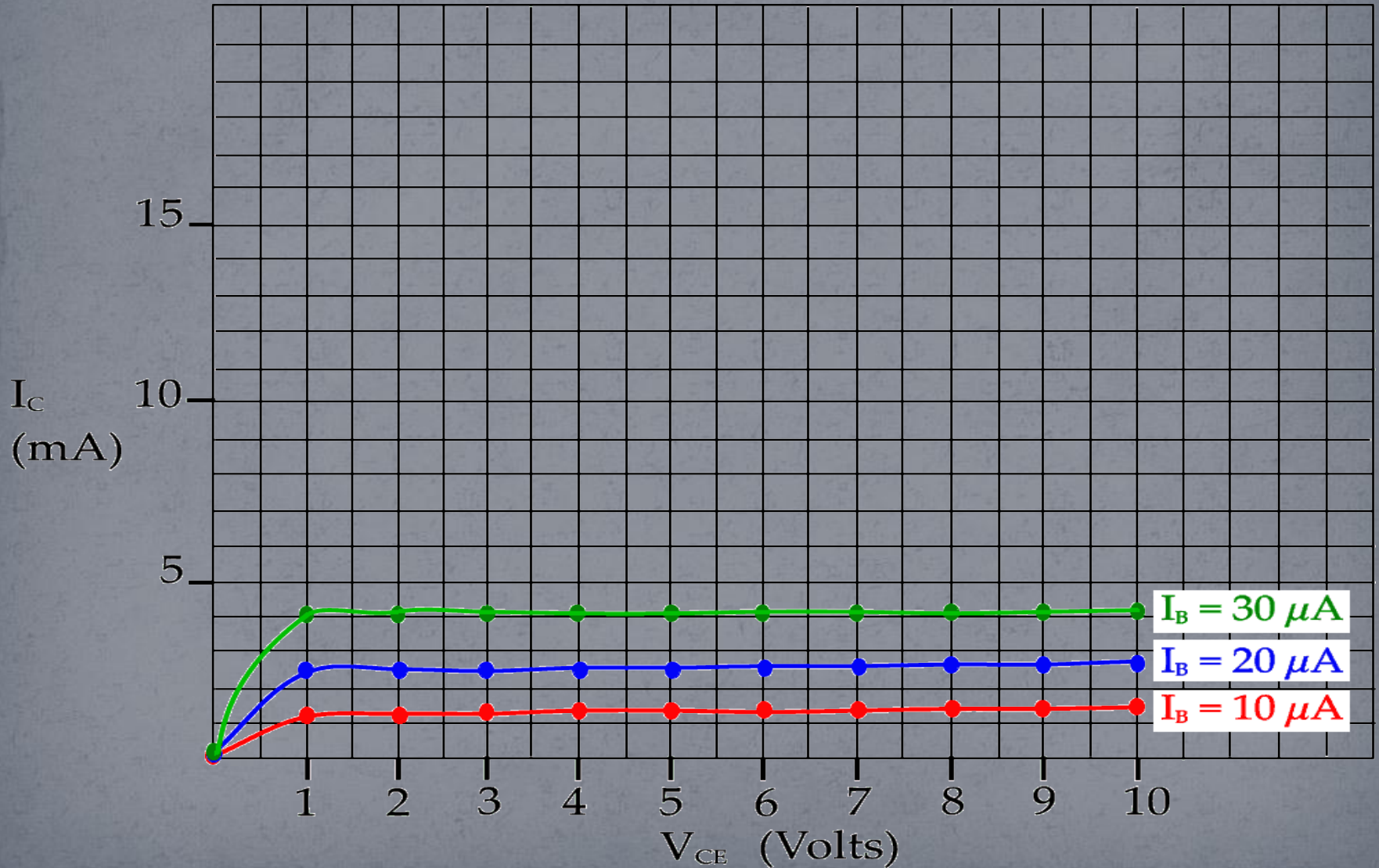

1432, Exp. 2, Q3, Characteristic Curves

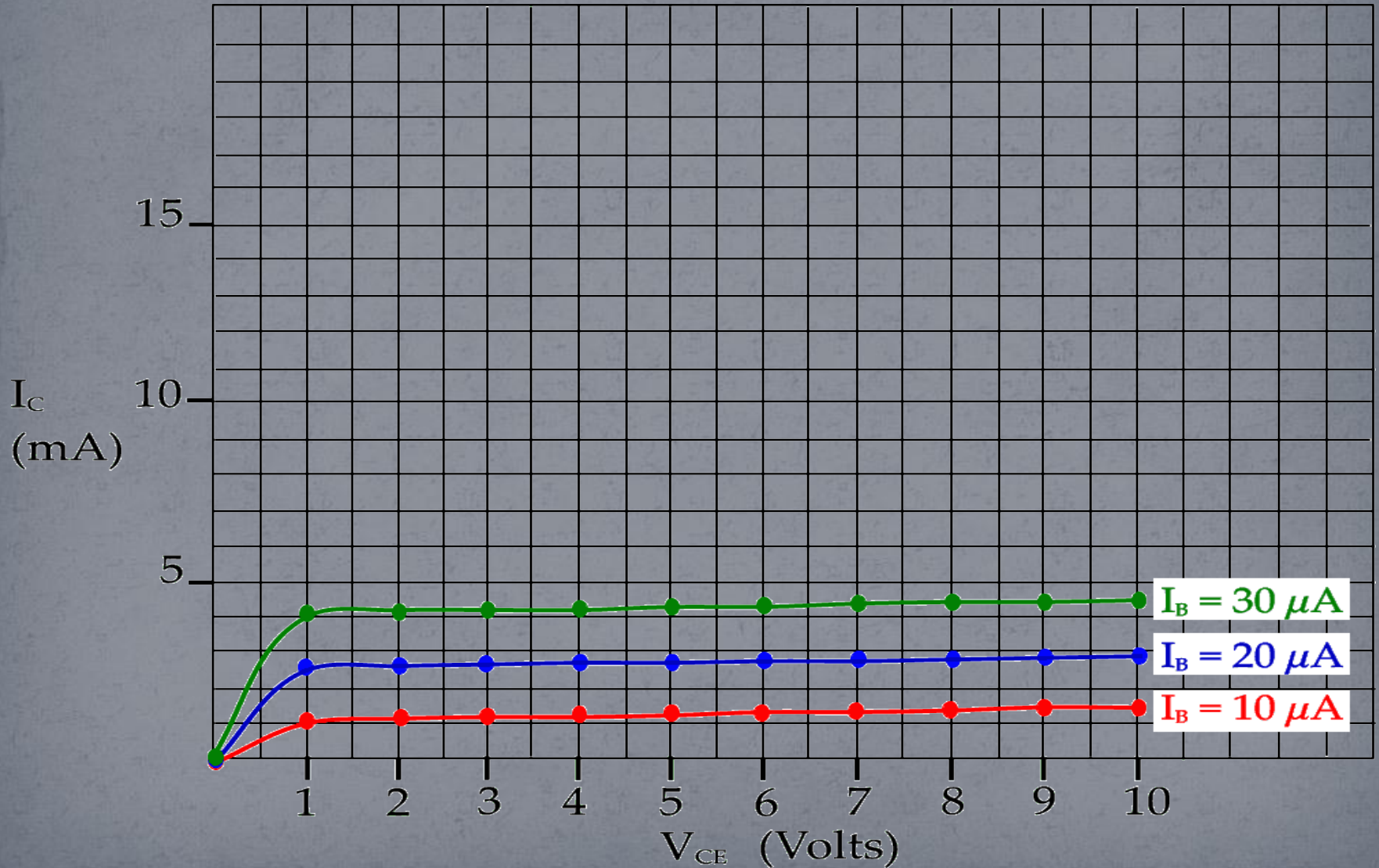

Exp. 2, Current Gain Cal. Data Table

	@ $V_{CE} = 5\text{ V}$	Q_1	Q_2	Q_3
1	I_C ($I_B = 20\ \mu\text{A}$)	5.85 mA	2.72 mA	2.8 mA
2	β_{D-C}	292.5	136	140
3	I_C ($I_B = 20\ \mu\text{A}$)	2.1 mA	1.4 mA	1.35 mA
4	I_C ($I_B = 20\ \mu\text{A}$)	11.4 mA	4.2 mA	4.3 mA
5	β_{A-C}	465	140	147.5

CIE Results Continued

6. No: don't...Of course it is possible for two samples of the same transistor type to have the same characteristics. However, such a possibility is very slight
13. Don't...See the Current Gain Calculations Data Table
14. Don't...See the I Gain Calc. Data Table

Final Discussion

- In this experiment, you measured the characteristics of two MPSA 20 transistors.
 - Using the family of characteristic curves obtained from these two transistors along with the family of curves from the transistor in experiment 1, you were able to make direct comparisons of the characteristics of a total of 3 transistors

- You were also able to use the curves to calculate the AC and DC current gains and see how they compared
- You probably obtained different characteristics for each of the three MPSA20 transistors.
- Although, it is possible, just barely, that the characteristics of two transistors were exactly the same

- However, it is far more likely, the differences of the three transistors were readily apparent.
 - This allowed you to see the extreme variability that can be expected in the characteristics of such solid state devices
- The current gain calculations for all three devices should have been somewhat different as well.

- Again, the probability of identical gain characteristics is remote.
- The stated tolerance for the current gain of an MPSA20 transistor is in the range of 40-400.

QUESTIONS?



Resources

- Rosenow, K. (2001). *Lesson 1432: Common-Emitter Amplifier Characteristics*. Cleveland: Cleveland Institute of Electronics.

The End

**Developed and Produced by the
Instructors in the CIE Instruction
Department.**

© Copyright 12/2012

All Rights Reserved / Dec. 2012