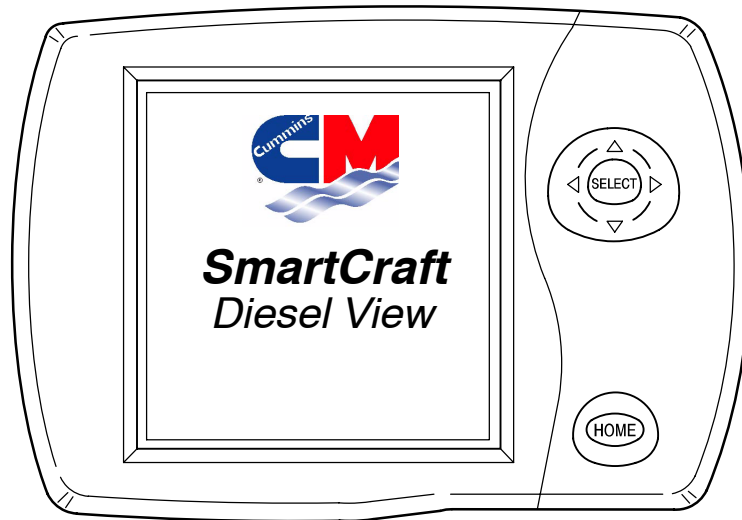

Cummins Mercruiser Diesel

SmartCraft

Diesel View

Version 1.00

Configuration and Operation Manual



CONTENTS

Section 1 - Introduction

Section 2 - Getting Started

- Starting Up the System View
- Display Screens

Section 3 - Propulsion

- Propulsion Information
- Entering the Propulsion Directory
- Propulsion Data Screens

Section 4 - Vessel

- Vessel Information
- Entering the Vessel Directory
- Vessel Data Screens

Section 5 - Navigation/Fuel

- Navigation/Fuel Information
- Entering the Navigation/Fuel Directory
- Navigation/Fuel Data Screens

Section 6 - Settings

- Settings Information
- Entering the Settings Directory
- Settings Directory
- Settings Options







Section 7 - Systems

- System Information
- Entering the System Directory
- System Calibration
- Maintenance Log
- Active Alarms
- Alarm History

Section 8 - Installation

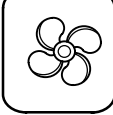
- Components
- Special Instructions
- Installation Information
- Diesel View Installation
- Wiring Information for SmartCraft
- Connecting Optional GPS Unit to the System View

Section 9 - Index

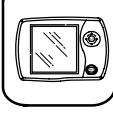
| | | |
|--|-----------------|---|
|  | INTRODUCTION | 1 |
|  | GETTING STARTED | 2 |
|  | PROPULSION | 3 |
|  | VESSEL | 4 |
|  | NAVIGATION/FUEL | 5 |
|  | SETTINGS | 6 |
|  | SYSTEMS | 7 |
|  | INSTALLATION | 8 |
| A to Z | INDEX | 9 |

Introduction

1

The Diesel View Display is a comprehensive boat information center. Diesel View allows the boat operator to receive a wealth of critical operational information, displayed clearly and instantly at the helm on the LCD display. The Diesel View continuously monitors and reports information ranging from basic operating data to detailed vessel environment information. Diesel View continuously display multiple engine operating parameters as well as vessel sensor inputs. In addition, the Diesel View displays preventive maintenance reminders as well as systems diagnostics. Diesel View also can be fully integrated with the boat's GPS, if equipped, to provide up to the minute course, speed, and fuel-to-destination information.

Another important feature of the Diesel View display is the monitoring and display of C-Cruise activation switch states. The top center portion of the Diesel View display is reserved for indication of the C-Cruise switch status. This information provides the operator with real-time indication of the operational mode of the engines.

For additional details on the Diesel View display and associated SmartCraft system components implemented on Cummins Mercruiser Diesel products, reference the following documentation.

SmartCraft system Specification and Installation Guidelines Drawing # 3970189

SmartCraft Marine Application Bulletin MAB# 0.15.00 – 08/04/2003

Diesel View Displays Detailed Information in These Important Categories:

***NOTE:** The detailed information listed which is standard on some models may be optional on others, or may not be available on some models based on engine and system configuration.*

Propulsion Information Section 3

Engine Parameter Information

- Engine RPM
- Coolant Temperature
- Oil Pressure
- Engine Oil Temperature
- Battery Voltage
- Intake Manifold Temperature
- Instantaneous Fuel Flow
- Turbo Boost Pressure
- Percent Throttle Commanded
- Percent Engine Load
- Ambient Air Pressure
- Gear Oil Pressure
- Gear Oil Temperature

Engine Fault Information

INTRODUCTION

Vessel Information Section 4

- Steering angle display
- Fuel tank, oil tank, water tank, and waste water tank level display
- Total Engine Hours
- Total Fuel Consumed

Navigation and Fuel Section 5

- Direction to target waypoint information shows present course and current speed on a graphic compass rose
- Shows distance, time, speed, and fuel to next waypoint
- Resettable trip history shows miles per hour, miles per gallon, elapsed drive time, and amount of fuel consumed on current trip
- Water depth with depth history graph
- Sea water temperature with temperature history graph

Settings Section 6

Alarm, Diagnostic, and Maintenance Information Section 7

- Displays alarms and helpful information concerning alarm causes. Refer to Section 3 for a detailed listing of propulsion engine alarm descriptions.
- Automatic maintenance reminders and log recorder for periodic propulsion maintenance

Keypad Usage

The System View uses icons and text selection to perform all the functions.

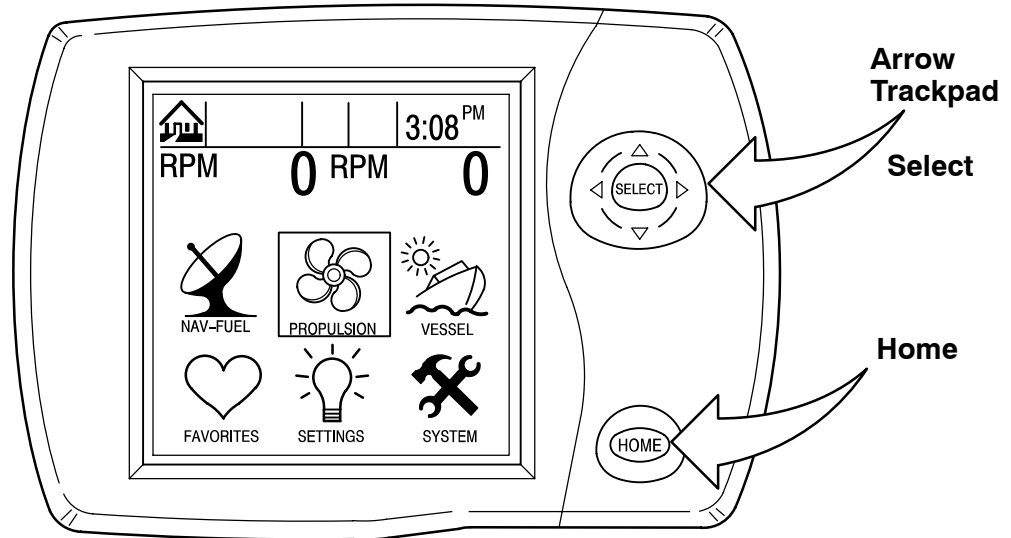

The **ARROW TRACKPAD** controls up and down and side to side movement for on-screen function prompts.



The **SELECT** key is used to select screen options and confirm data entry.



The **HOME** key returns the display to the home page and also lets you turn the System View on/off if you do not use the main key switch.

NOTES:

GETTING STARTED

Section 2

Table of Contents



| | |
|-----------------------------------|-----|
| Starting up the Diesel View | 2-2 |
| Display Screens | 2-2 |
| Start-up Screens | 2-2 |
| Home Page Screen | 2-3 |
| Data Display Screens | 2-5 |
| Alarm Message Screens | 2-9 |

GETTING STARTED

Starting Up the Diesel View

Turning on the main engine switch will start up the Diesel View. The Diesel View will move through a sequence of start-up screens shown below. Pressing **SELECT** will pause the screen.

Display Screens

Start-Up Screens

The start-up screens can be set to display home page (Step 1) or the last display shown before power off (Step 2). To select a setting, refer to “Setting/Preferences/Start-up Page” menu in Section 6.

1. Start-up screens will appear in sequence ending at the home page.
2. Calibration screen – This screen only appears if initial setup calibration has not been performed. Press **SELECT** to perform calibration procedures. Please refer to “System Calibration” in Section 7.

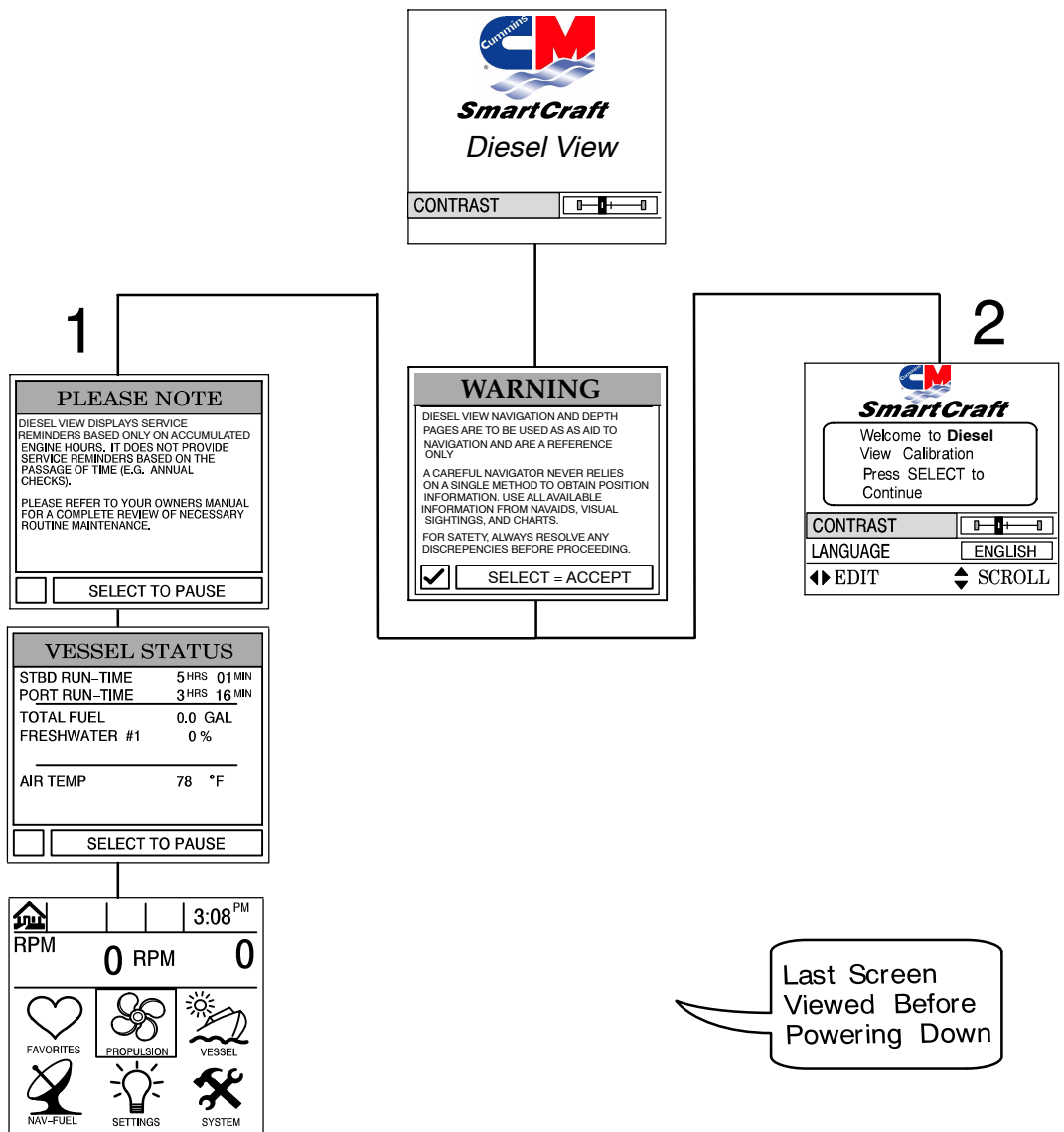

Display Screens

Home Page Screen

Across the bottom half of the home page you will find six on-screen main directory selections.

Use the trackpad to highlight the directory choice. Press **SELECT** to accept your choice and to open the directory screen.

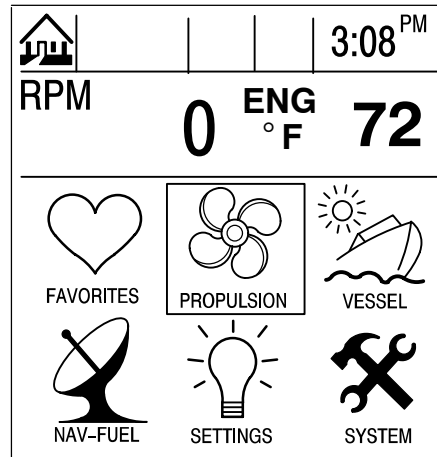

NAV-FUEL (See Section 5)

- Direction to target waypoint information shows present course and current speed on a graphic compass rose
- Shows distance, time, speed, and fuel to next waypoint
- Resettable trip history shows miles per hour, miles per gallon, elapsed drive time and amount of fuel consumed on current trip
- Water depth with depth history graph
- Sea water temperature



PROPULSION (See Section 3)

- Engine RPM combined with boat speed
- Twin Engine synchronizer display
- Peak boat speed in conjunction with peak engine RPM
- Engine Parameter Information(See pg.1-1)



VESSEL (See Section 4)

- Steering angle display
- Fuel tank, water tank, and waste water tank level display
- Total engine hours
- Total fuel consumed



FAVORITES (See Section 6)

- Collection of Screens Selected by the User



SETTINGS (See Section 6)

- Contrast/Lighting/Clock
- Units/Language/Offsets
- Sensors
- Favorites/Page Status



SYSTEM (See Section 7)

- Maintenance Log
- Active Alarms
- Alarm History
- System Calibration

Display Screens

Home Page Screen (Continued)

The top half of the home page displays engine data and vessel data. The engine data is received from sensors on the engine and the vessel data is received by vessel sensors.

The initial screen layout takes one of two forms depending on whether one or two engines are installed. Defaults for the engine data include engine RPM and engine temperature. Default for vessel data is water depth.

The data displays can be selected by the user to display the functions. Refer to “Settings/Preferences/Home Page Data” Menu in Section 6.

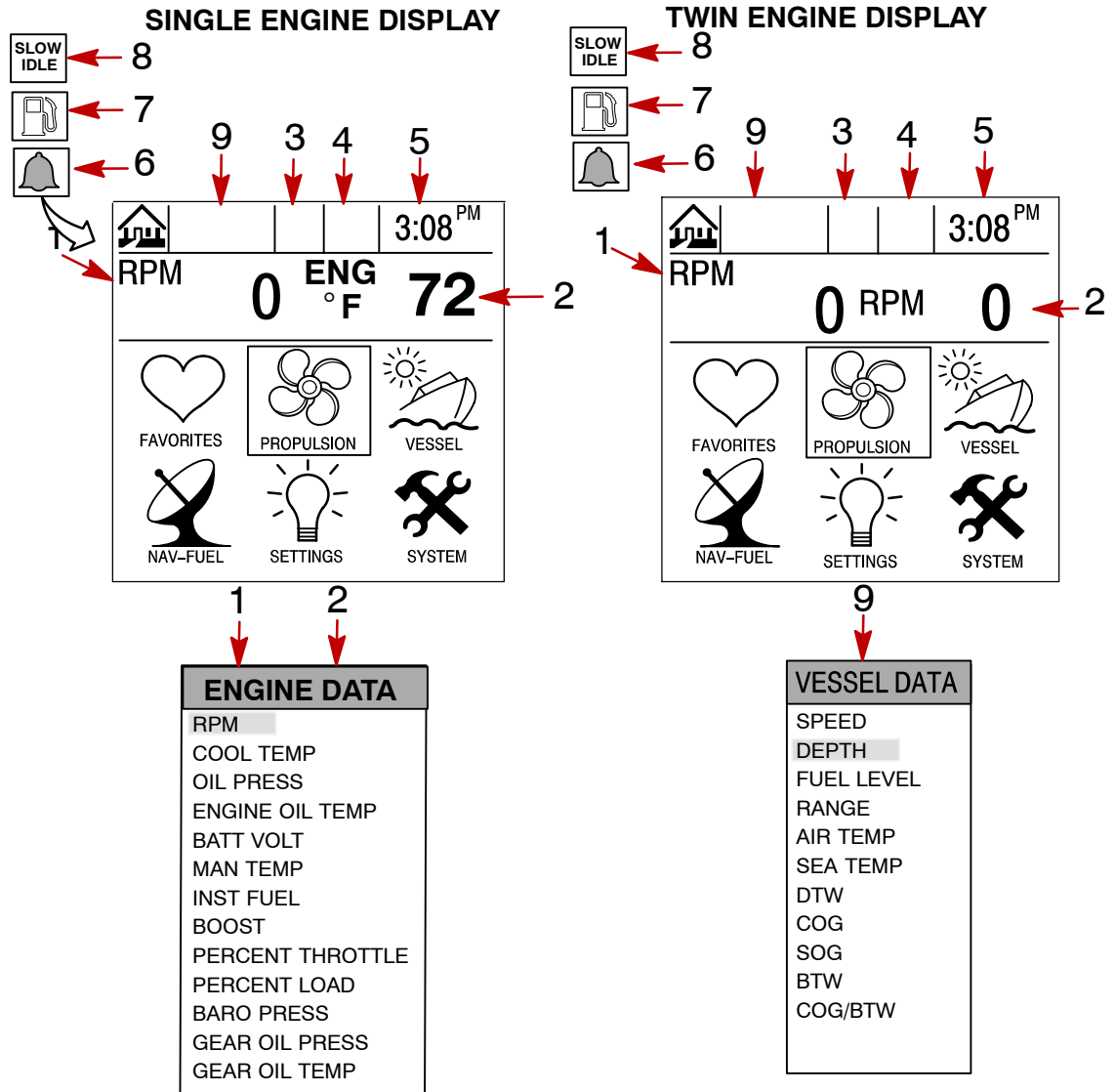

- 1 - Engine Line 1 – Refer to Section 3 for selection
- 2 - Engine Line 2 – Refer to Section 3 for selection
- 3 - Engine synchronization indicator
- 4 - Cruise 1, Cruise 2
- 5 - Clock – Refer to Section 6 for setting
- 6 - Flashing Bell Icon – Warning alarm is activated
- 7 - Flashing Fuel Icon – Low fuel alarm
- 8 - Slow Idle Indicator
- 9 - Vessel Data

Display Screens

Data Display Screens

The data display screens can be selected from the main directory menu choices which are selected from the home page.

The current directory menu selection icon is displayed in top-left of the display.

The presentation of information on-screen will be shown in the information window located at the bottom on the screen.

Alarm Notice – When a problem is detected, the name of the offending alarm will appear in the information window and a bell symbol at the bottom of the screen flashes. The bell symbol will continue to flash as long as the alarm condition is still present. If there are multiple alarms, these will cycle on the display screen.

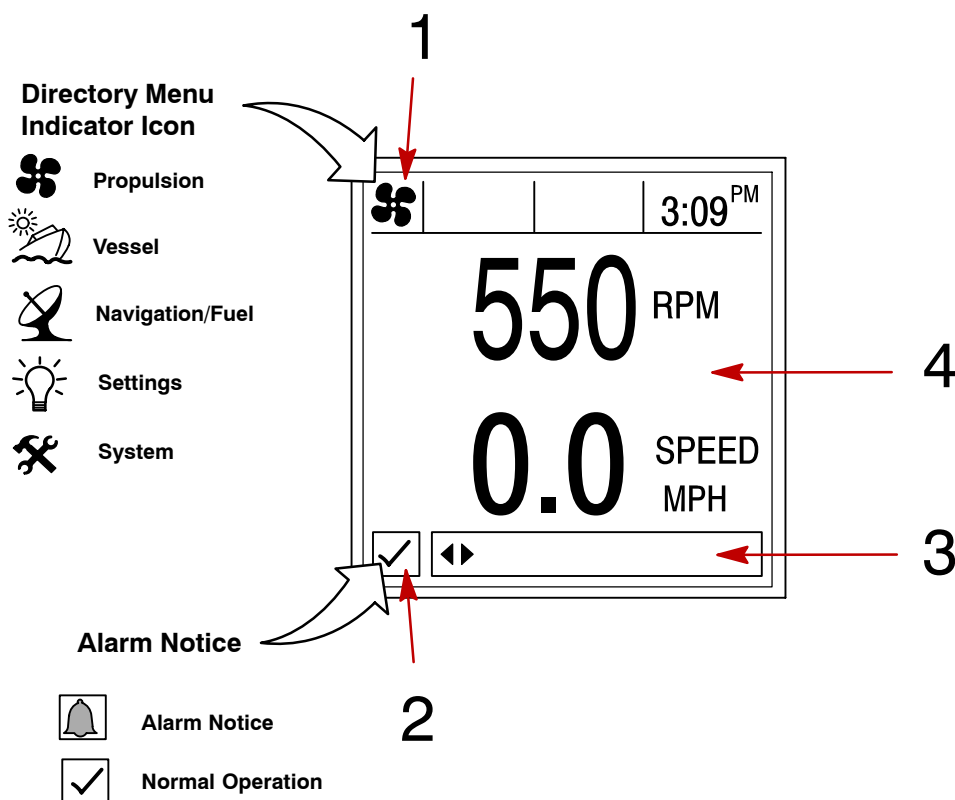





- 1 - Directory identification icon
- 2 - Alarm window
- 3 - Information window
- 4 - Display screen

GETTING STARTED

Display Screens

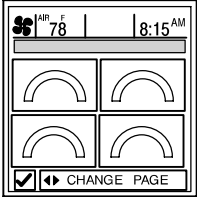
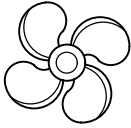
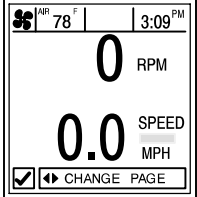
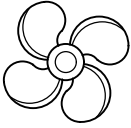
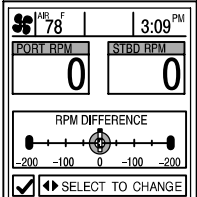
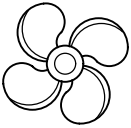
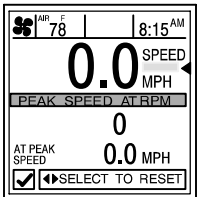
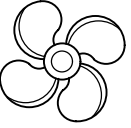
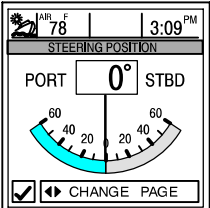
Data Display Screens

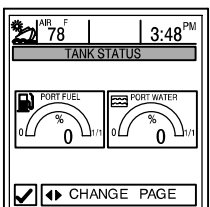





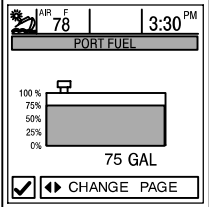
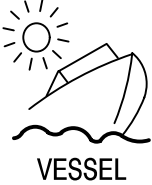
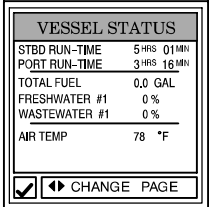
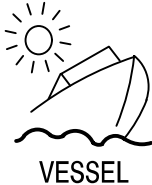
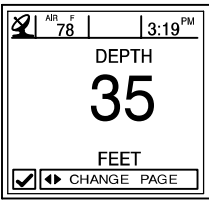

Glossary

| Data | Screen | Directory Location |
|--|--|---|
| <p>Engine Data Screen(s)</p> <p>Engine data screen(s) is a group of displays showing various engine data.</p> <p>All Engine data on page 2-4, except RPM can be displayed in this format.</p> |  |  <p>PROPULSION</p> |
| <p>Engine RPM and Speed</p> <p>Displays engine RPM and boat speed.</p> |  |  <p>PROPULSION</p> |
| <p>Engine RPM Synchronizer</p> <p>Twin Engines – Displays the difference in engine speed (RPM) between the port and starboard engines</p> |  |  <p>PROPULSION</p> |
| <p>Peak Speed at RPM</p> <p>This screen records the top speed the boat reached and associated engine RPM as measured since the last reset.</p> |  |  <p>PROPULSION</p> |
| <p>Steering Position</p> <p>Displays steering position in degrees.</p> |  |  <p>VESSEL</p> |
| <p>Tank Status</p> <p>Shows level of the vessel's tanks.</p> |  |  <p>VESSEL</p> |

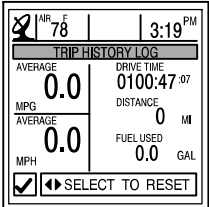
Display Screens

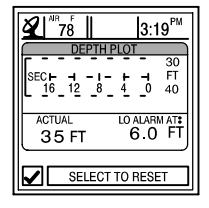
Data Display Screens

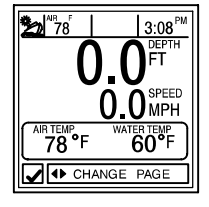
Glossary







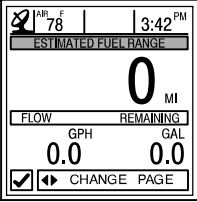

| Data | Screen | Directory Location |
|--|--|---|
| <p>Tank Levels</p> <p>Displays the level of each tank.</p> |  |  <p>VESSEL</p> |
| <p>Vessel Status</p> <p>Displays engine run time Total fuel remaining Additional tank levels Air temperature</p> |  |  <p>VESSEL</p> |
| <p>Depth</p> <p>Displays the depth of water.</p> |  |  <p>NAV-FUEL</p> |
| <p>Trip History Log</p> <p>Displays average fuel economy, average boat speed, total drive time, along with a corresponding distance traveled and fuel used.</p> |  |  <p>NAV-FUEL</p> |
| <p>Depth Plot Line</p> <p>Displays a plot line of depth vs. time as recorded over the last 16 seconds.</p> |  |  <p>NAV-FUEL</p> |
| <p>Environment</p> <p>Displays speed, depth, air temperature, and sea water temperature.</p> |  |  <p>NAV-FUEL</p> |

GETTING STARTED

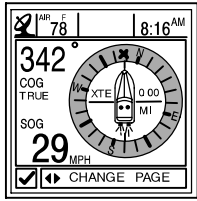
Display Screens

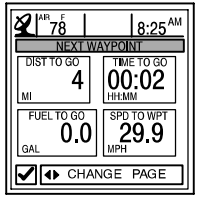
Data Display Screens

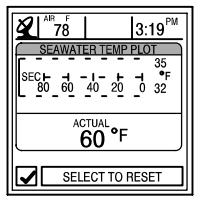
Glossary

| Data | Screen | Directory Location |
|--|--|---|
| <p>Estimated Fuel Range</p> <p>Displays estimated range and fuel remaining, as well as current total fuel flow.</p> |  |  <p>NAV-FUEL</p> |
| <p>Navigation Screen 1</p> <p>Displays a compass and shows direction to a targeted waypoint.</p> |  |  <p>NAV-FUEL</p> |
| <p>Navigation Screen 2</p> <p>Displays navigating data to a waypoint.</p> |  |  <p>NAV-FUEL</p> |
| <p>Seawater Temperature Plot Line</p> <p>Displays a plot line of seawater temperature vs. time as recorded over the last 80 seconds. Also displays the current water temperature.</p> |  |  <p>NAV-FUEL</p> |

Display Screens

Alarm Message Screens

When a problem is detected, the Diesel View will alert the operator. Use the following steps to determine the cause of the problem:

1. A pop-up screen will appear displaying an alarm message. If there are multiple alarms, the display will show the last alarm activated.
2. Press **SELECT** to clear the pop-up screen(s) and return back to the display screen that was being viewed. Bell icon will now be flashing and alarm message will be displayed on the bottom of the screen.
3. A number of different problems may be grouped together under one alarm message. To determine the exact cause of the problem, return back to the home page and access the **SYSTEM** directory. The **SYSTEM** directory will show the active alarm(s) causing the problem.
4. Refer to the "Active Alarms" in Section 7 for further explanation of the problem and the correct action to take.

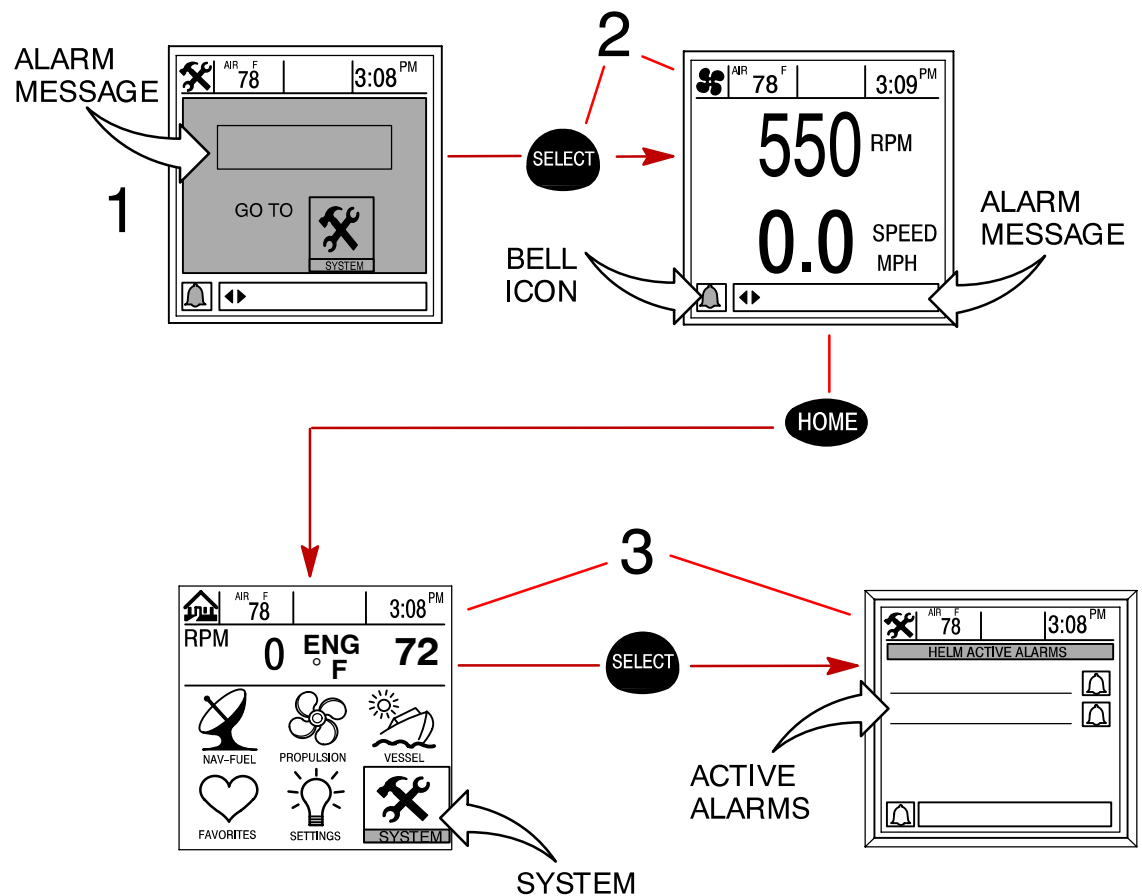

NOTES:

PROPULSION

Section 3

Table of Contents

| | |
|---|-----|
| Propulsion Information | 3-2 |
| Entering the Propulsion Directory | 3-2 |
| Propulsion Data Screens | 3-3 |



PROPULSION

Propulsion Information

This Section will give a complete description of the display screens in the **PROPULSION** directory of the Diesel View.

Some of the propulsion functions are:

- Engine RPM combined with boat speed
- Trim engine synchronizer display
- Peak boat speed in conjunction with peak engine RPM
- Fuel consumption
- Propulsion Information
- Vessel Information
- Engine Fault Information

Entering the Propulsion Directory

To access the **PROPULSION** directory, use the trackpad to highlight the **PROPULSION** directory from the menu choice. Press **SELECT** to accept and to open the directory.

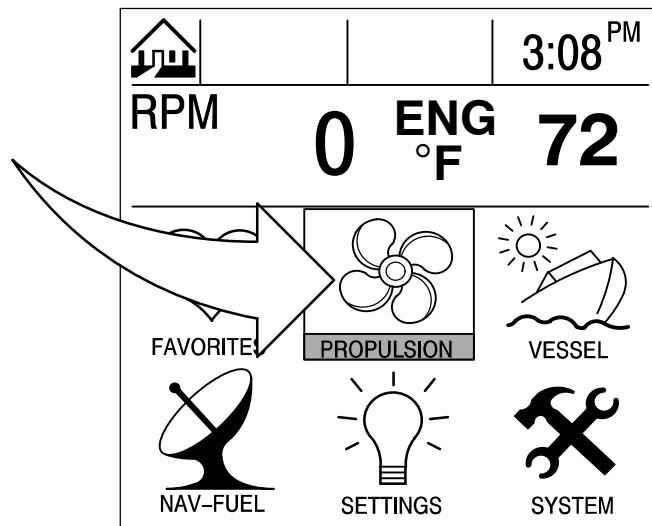

Propulsion Data Screens

Engine RPM/Speed

This screen displays engine speed (RPM) and boat speed.

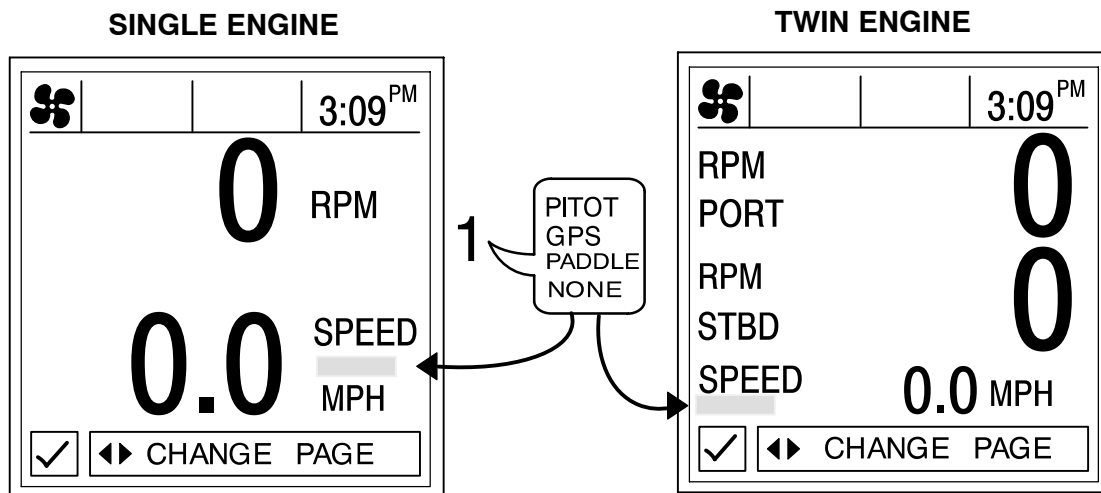

- 1 - Speed Sensors – This window shows the sensor that is currently sending the speed signal. The speed sensor is automatically selected based on what sensors are available.

Peak Speed at RPM

This screen records the top speed the boat reached and associated engine RPM as measured since the last reset.

To **Reset** the Peak Speed and corresponding RPM, press and hold the **SELECT** button momentarily.

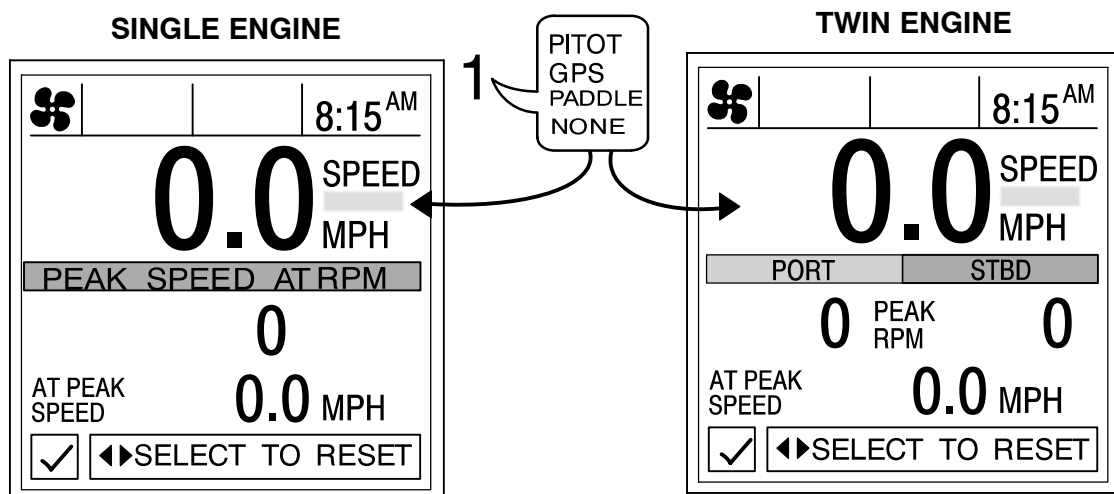

- 1 - Speed Sensors – This window shows the sensor that is currently sending the speed signal. The speed sensor is automatically displayed based on what sensors are available.

Propulsion Data Screens

Engine RPM Synchronizer – Twin Engine

This screen displays the difference in engine speed (RPM) between the port and starboard engines. Allows throttle adjustments to keep each engine running uniformly.

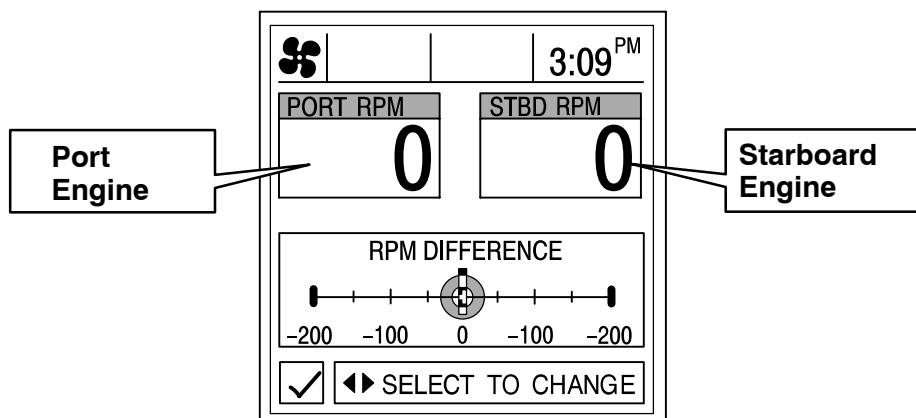

Engine Data Screen(s)

Engine data screen(s) is a group of displays showing various engine data. This data is transmitted via the high speed CAN link and the data screens are updated as this data.

NOTE: Not all screens listed may be available for your type of engine.

ENGINE COOLANT TEMPERATURE – Displays current temperature of the fluid in the engine cooling system. The temperature will vary with air temperature, water temperature and operating conditions.

ENGINE OIL PRESSURE – Displays engine oil pressure when the engine is running. The oil pressure may vary with engine speed, outside temperature and oil viscosity. While the engine is warming up, the oil pressure will be higher than when the engine is at normal operating temperature.

ENGINE OIL TEMPERATURE – Displays current temperature of engine lubricating oil. The temperature will vary depending on engine speed, engine load, coolant temperature and vessel operating conditions.

BATTERY VOLTAGE – Displays voltage level (condition) of the engine battery. System capable of monitoring battery voltage range of 8–32 VDC.

INTAKE MANIFOLD TEMPERATURE – Displays current temperature of intake manifold air. Intake air temperature will vary depending on the engine speed, engine load, cooling system efficiency and vessel operating conditions.

INSTANTANEOUS FUEL FLOW – Displays instantaneous fuel consumption rate based on current operating mode of the engine.

TURBO BOOST PRESSURE – Displays boost pressure being developed by the engine turbocharger. Data reported in inches of Mercury (IN/HG).

PERCENT THROTTLE COMMANDED– Displays current commanded throttle position. Valid throttle percentage range is from 0% to 100%. Idle engine speed is commanded at 0% throttle and rated (high idle) engine speed is commanded at 100% throttle.

PERCENT ENGINE LOAD – Displays current load demand on the engine. Valid load percentage range is from 0% to 100% engine load will vary depending on commanded throttle and vessel loading due to vessel displacement, hull characteristics and propeller matching.

AMBIENT AIR PRESSURE – Displays the relative ambient air pressure. Ambient air pressure is measured at the engine location.

GEAR OIL PRESSURE – Displays the current value of the fluid pressure internal to the marine gear. Pressure within the gear will vary between two points depending on engagement state of the clutch pack.

GEAR OIL TEMPERATURE – Displays the current temperature of the marine gear oil. %

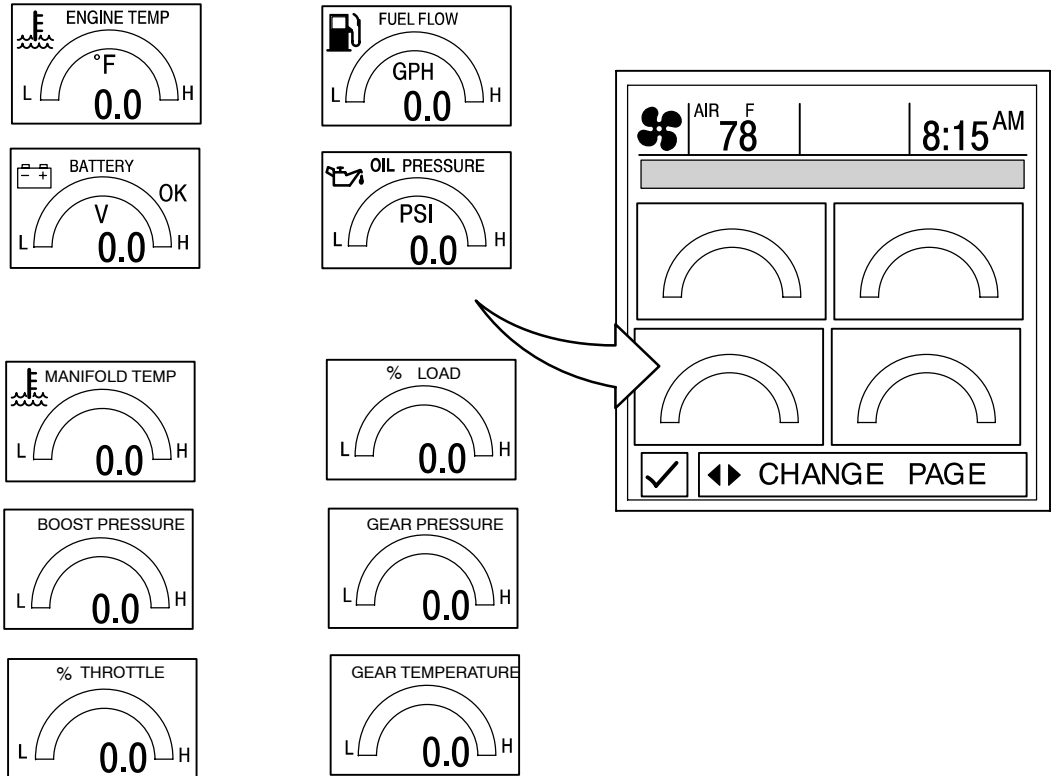

Propulsion Data Screens –

Engine Fault Information

This Section will provide a complete description of the fault codes announced by the Diesel View display. There are two types of fault conditions which are major and minor. Major fault conditions will provide a visual pop-up over any active screen. These faults require immediate attention.

Other faults that may occur are considered minor faults. The operator will be required to navigate to the SYSTEM menu to query the fault condition. Both major and minor faults are shown in the table below.

Fig. 5 – Primary Engine Faults

| Fault Code Number | SPN | FMI | Explanation | Action | Horn |
|-------------------|---------|------|--|--|------|
| 111 | 629 | 12 | Internal ECM failure | Engine will not start. Diagnose ECM failure | Yes |
| 122 | 102 | 3 | Intake manifold pressure sensor fault. Voltage high. | Engine will continue to run using default value. Repair at dock. | |
| 123 | 102 | 4 | Intake manifold pressure sensor fault. Input voltage out of range low. | Engine will continue to run using default value. Repair at dock. | |
| 131 | 91 | 3 | Throttle signal out of range high. | Check throttle signal inputs. Engine may only idle. | Yes |
| 132 | 91 | 4 | Throttle signal out of range low. | Check throttle signal inputs. Engine may only idle. | Yes |
| 133 | 974 | 3 | Remote/backup throttle signal out of range low. | Check throttle signal inputs. | Yes |
| 134 | 974 | 4 | Remote accelerator position sensor circuit shorted low. | Check throttle signal inputs. | |
| 135 | 102 | 0 | Oil pressure sensor fault. Input voltage out of range high. | Engine will continue to run using default value. Repair at dock. | |
| 141 | 100 | 4 | Oil pressure sensor fault. Input voltage out of range low. | Engine will continue to run using default value. Repair at dock. | |
| 143/415 | 100/100 | 18/1 | Low oil pressure. | Stop engine. Damage may occur. Check oil level and look for leaks. | Yes |
| 144 | 110 | 3 | Coolant temperature sensor fault. Input voltage out of range high. | Engine will continue to run using default value. Repair at dock. | |
| 145 | 110 | 4 | Coolant temperature sensor fault. Input voltage out of range low. | Engine will continue to run using default value. Repair at dock. | |
| 146 | 110 | 16 | Coolant temperature high - moderately severe level. | Reduce throttle. Damage may occur. | |

| Fault Code Number | SPN | FMI | Explanation | Action | Horn |
|--------------------------|------------|------------|--|--|-------------|
| 151 | 110 | 0 | High coolant temperature. | Reduce throttle. Damage may occur. | Yes |
| 153 | 105 | 3 | Intake Manifold temperature sensor fault, Input voltage out if range high. | Engine will continue to run using default value. Repair at dock. | |
| 154 | 105 | 4 | Intake Manifold temperature sensor fault, Input voltage out if range low. | Engine will continue to run using default value. Repair at dock. | |
| 155 | 105 | | High Intake manifold temperature | Reduce throttle. Damage may occur. Sea water pump flow may be low. Check sea stainers and pump impeller. | Yes |
| 187 | 620 | 4 | ECM sensor internal power supply voltage low. | Sensor inputs for oil pressure and coolant level may be out of range low. Diagnose high current draw or internal ECM power supply-failure. | |
| 195 | 111 | 3 | Coolant level sensor circuit - voltage high. | Engine will continue to run using default value. Repair at dock. | |
| 196 | 111 | 4 | Coolant level sensor circuit - voltage low. | Engine will continue to run using default value. Repair at dock. | |
| 197 | 111 | 18 | Coolant level low - moderately severe level. | Engine will continue to run using default value. Repair at dock. | |
| 227 | 620 | 3 | ECM sensor internal power supply voltage high. | Sensor inputs for oil pressure and coolant level may be out of range low. Diagnose internal ECM power supply failure. | |
| 234 | 190 | 0 | Engine overspeed. | Stop engine. Damage may occur. | YES |
| 235 | 111 | 1 | Low coolant level. | Stop engine. Damage may occur. | YES |
| 237 | 644 | 2 | Engine Sync fault. | Engine sync will not activate. Improper engine addressing or loss of communication between engines. | |
| 268 | 94 | 2 | Full pressure signal is not changing. | Engine will continue to run. Power may be reduced. | |
| 271 | 1347 | 4 | High fuel pressure solenoid valve circuit - low voltage. | Engine will continue to run. Erratic engine operation may occur. | |

PROPULSION

| Fault Code Number | SPN | FMI | Explanation | Action | Horn |
|-------------------|------|-----|---|---|------|
| 272 | 1347 | 3 | High fuel pressure solenoid valve circuit - high voltage. | Engine will continue to run. Erratic engine operation may occur. | |
| 275 | 1347 | 7 | Fuel pumping element (front) not responding properly. | Engine will continue to run. Erratic engine operation may occur. | |
| 284 | 1043 | 4 | Engine speed/position sensor (crankshaft) supply voltage circuit - low voltage. | Engine will continue to run. Erratic engine operation may occur. | |
| 285 | 639 | 9 | Multiple message time out. | Check connections between engine and helm control/display devices. | |
| 287 | 91 | 19 | J1939 throttle sensor system fault. | Engine may not respond to throttle commands. Engine may only idle. | |
| 288 | 974 | 19 | J1939 remote throttle sensor system fault. | Engine may not respond to remote throttle commands. Engine may only idle. | |
| 322 | 651 | 5 | Cylinder #1 injector fault. | Repair immediately. | |
| 323 | 655 | 5 | Cylinder #5 injector fault. | Repair immediately. | |
| 324 | 653 | 5 | Cylinder #3 injector fault. | Repair immediately. | |
| 325 | 656 | 5 | Cylinder #6 injector fault. | Repair immediately. | |
| 331 | 652 | 5 | Cylinder #2 injector fault. | Repair immediately. | |
| 332 | 654 | 5 | Cylinder #4 injector fault. | Repair immediately. | |
| 341 | 630 | 2 | Data loss from ECM | Diagnose at earliest convenience. | |
| 351 | 629 | 12 | Injector boost voltage is low. | | |
| 387 | 1043 | 3 | ECM throttle sensor internal power supply voltage high. | Engine will only idle. Diagnose short to high voltage circuit. | |
| 418 | 97 | 15 | Water has been detected in the fuel filter - least severe level. | Possible white smoke, loss of power or hard starting. | |
| 426 | 639 | 2 | J1939 communications lost. | Check J1939 data link connections. | |
| 428 | 97 | 3 | Water in fuel sensor circuit - high voltage. | Check for water in fuel filters. | |
| 429 | 97 | 4 | Water in fuel sensor circuit - low voltage. | Check for water in fuel filters. | |
| 431 | 558 | 2 | Idle validation fault. Both circuits closed. | Diagnose simultaneous voltage on both idle and off-idle circuits. | |

| Fault Code Number | SPN | FMI | Explanation | Action | Horn |
|--------------------------|------------|------------|---|--|-------------|
| 432 | 558 | 13 | Idle validation fault. Throttle input and validation switches don't agree. | Diagnose validation switch position and throttle position. | |
| 441 | 168 | 18 | Battery voltage to ECM low. | Check power circuits to ECM and battery conditions. | |
| 442 | 168 | 16 | Battery voltage to ECM high. | Check power circuits to ECM. | |
| 443 | 1043 | 4 | Throttle position sensor supply circuit - voltage low. | Severe derate in engine speed. Limp home capability only. | |
| 449 | 94 | 16 | Fuel pressure has exceeded the maximum limit for the given engine rating. | Engine will continue to run. Erratic engine operation may occur. | |
| 451 | 157 | 3 | High signal voltage detected at the rail pressure sensor circuit. | Engine will continue to run. Erratic engine operation may occur. | |
| 452 | 157 | 4 | Low signal voltage detected at the rail pressure sensor circuit. | Engine will continue to run. Erratic engine operation may occur. | |
| 497 | 1377 | 2 | Engine sync fault. On/off and complimentary switches are not in opposite states. | Engine sync will NOT engage. Check which signal back to ECM inputs. | |
| 551 | 558 | 4 | Idle validation fault. Both circuits open. | Diagnose simultaneous lack of voltage on both idle and off-idle circuits. | |
| 689 | 190 | 2 | Primary engine speed sensor error - data erratic, intermittent, or incorrect. | Engine may run erratic. Engine may be difficult to start and speed may be reduced. | |
| 731 | 723 | 2 | Engine position signal from the crankshaft engine speed sensor and camshaft position sensor do not match. | Engine may run erratic. Engine may be difficult to start and speed may be reduced. | |
| 778 | 723 | 7 | Camshaft position sensor signal fault. | Engine may run erratic. Engine may be difficult to start and speed may be reduced. | |
| 784 | 653 | 6 | Loss of communication with adaptive cruise control - data erratic, intermittent, or incorrect. | None | |

PROPULSION

| Fault Code Number | SPN | FMI | Explanation | Action | Horn |
|-------------------|------|-----|---|--|------|
| 1117 | 627 | 2 | Power lost without ignition off - data erratic, intermittent, or incorrect. | No effect on engine performance. Trip history information may be inaccurate. | |
| 1139 | 651 | 7 | Cylinder #1 injector fault. | Repair immediately. | |
| 1141 | 652 | 7 | Cylinder #2 injector fault. | Repair immediately. | |
| 1142 | 653 | 7 | Cylinder #3 injector fault. | Repair immediately. | |
| 1143 | 654 | 7 | Cylinder #4 injector fault. | Repair immediately. | |
| 1144 | 655 | 7 | Cylinder #5 injector fault. | Repair immediately. | |
| 1145 | 656 | 7 | Cylinder #6 injector fault. | Repair immediately. | |
| 2215 | 94 | 18 | Fuel pressure is lower than commanded pressure - moderately severe level. | Engine may run erratic. Engine may be difficult to start and speed may be reduced. | |
| 2216 | 94 | 18 | Fuel pressure is higher than commanded pressure - moderately severe level. | Engine may run erratic. Engine may be difficult to start and speed may be reduced. | |
| 2265 | 1075 | 3 | High signal voltage detected at the electric supply/lift pump circuit. | Engine may run erratic. Engine may be difficult to start and speed may be reduced. | |
| 2266 | 1075 | 4 | Low signal voltage detected at the electric supply/lift pump circuit. | Engine may run erratic. Engine may be difficult to start and speed may be reduced. | |
| 2311 | 633 | 31 | Fueling actuator #1 circuit error - condition exists. | Engine may run erratic. Engine may be difficult to start and speed may be reduced. | |
| 2321 | 190 | 2 | Camshaft engine speed sensor intermittent sync.. | Engine may run erratic. Engine may be difficult to start and speed may be reduced. | |
| 2322 | 723 | 2 | Crankshaft engine speed sensor intermittent sync. | Engine may run erratic. Engine may be difficult to start and speed may be reduced. | |
| 2964 | 105 | 15 | Intake manifold temperature high - least severe level. | None | |
| 2973 | 102 | 2 | Intake manifold pressure sensor circuit - data erratic, intermittent, or incorrect. | None | |

In addition to the fault conditions broadcast by the engine control module, there are other Diesel View system faults. Those faults are described in the **SYSTEM** section of this document.

VESSEL**Section 4****Table of Contents**

| | |
|-------------------------------------|-----|
| Vessel Information | 4-2 |
| Entering the Vessel Directory | 4-2 |
| Vessel Data Screens | 4-3 |
| Steering Position | 4-3 |
| Tank Status | 4-3 |
| Fuel Tanks | 4-4 |
| Water and Waste Tanks | 4-4 |
| Vessel Status | 4-5 |

Vessel Information

This Section will give a complete description of the display screens in the **VESSEL** directory of the Diesel View.

Some of the vessel functions are:

- Steering angle position
- Tank status for fuel, oil, waste, and water
- Vessel status

Entering the Vessel Directory

To access the **VESSEL** directory, use the trackpad to highlight the **VESSEL** directory from the menu choice. Press **SELECT** to accept and to open the directory.

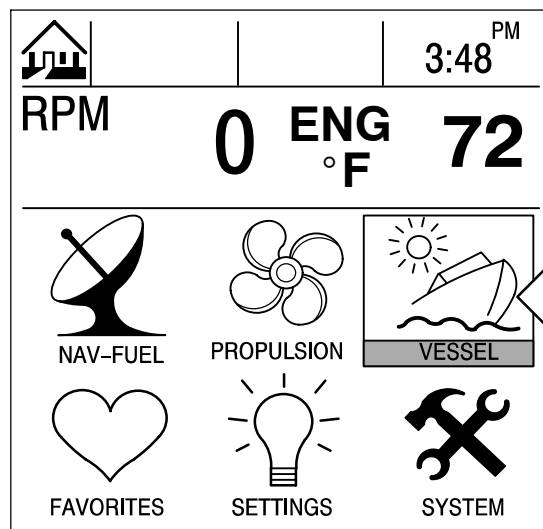

Vessel Data Screens

Steering Position

This screen displays steering position in degrees.

NOTE: Depending on your type of engine, this feature may not be available.

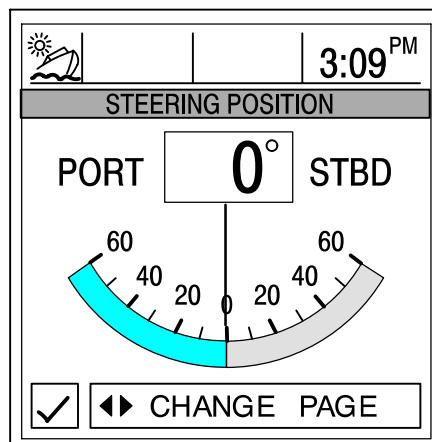

NOTE: If steering angle position is opposite the direction that it should be, it can be reversed so it is displayed properly. Refer to "Settings/Sensors/Invert Steering" Menu in Section 6.

Tank Status

NOTE: If your vessel installation includes tank level sensors, Diesel View will display fullness level that is provided by the sensors.

The display screens show the level of the vessels tanks. The bar gauges and digital read-outs indicate the level of fullness of each tank.

SCREEN 1

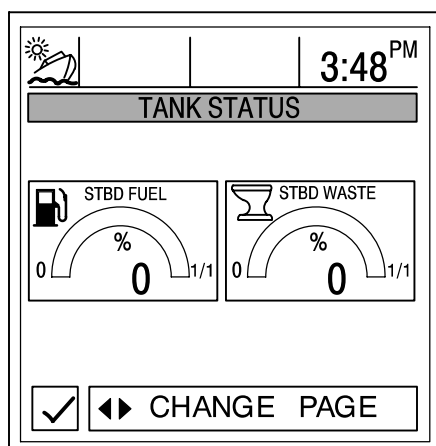

SCREEN 2

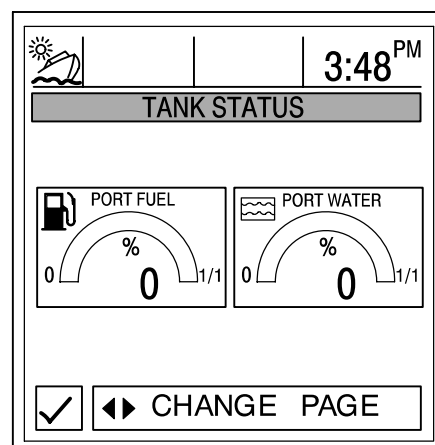

Vessel Data Screens

Fuel Tanks

Displays the level of each tank.

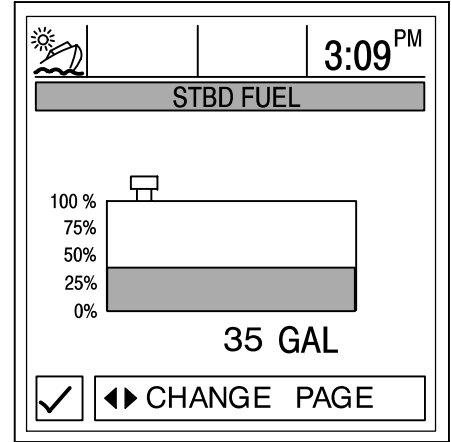
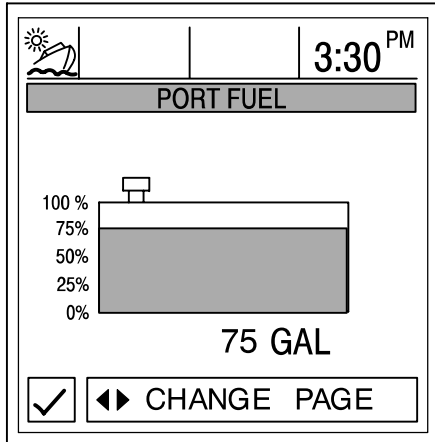

Water and Waste Tanks

Displays the level of each tank.

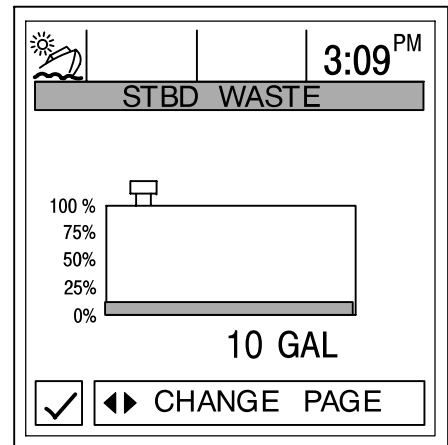
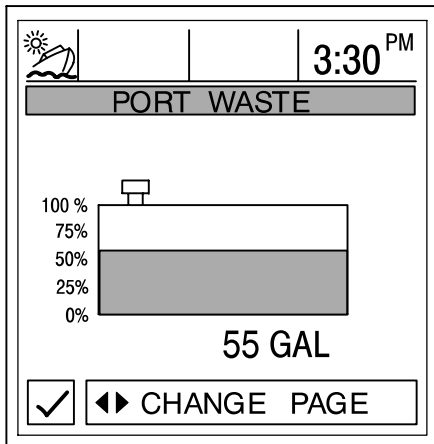

Vessel Data Screens

Vessel Status

Displays the current vessel information.

1. Displays run time in hours. These values are obtained directly from the engine ECM.
2. Displays the total fuel remaining.
3. Displays additional tank levels. Fresh water and waste water if connected.
4. Displays air temperature at sensor if connected.

| VESSEL STATUS | |
|---------------|--------------|
| STBD RUN-TIME | 5 HRS 01 MIN |
| PORT RUN-TIME | 3 HRS 16 MIN |
| <hr/> | |
| TOTAL FUEL | 0.0 GAL |
| FRESHWATER #1 | 0 % |
| WASTEWATER #1 | 0 % |
| <hr/> | |
| AIR TEMP | 78 °F |

1 →
2 →
3 →
4 →

◀▶ CHANGE PAGE

NOTES:

NAVIGATION/FUEL

Section 5

Table of Contents

| | |
|---|-----|
| Navigation/Fuel Information | 5-2 |
| Entering the Navigation/Fuel Directory | 5-2 |
| Navigation/Fuel Data Screens | 5-3 |
| Vessel Course | 5-3 |
| Next Waypoint Data | 5-4 |
| Trip History Log | 5-4 |
| Depth | 5-5 |
| Depth Plot Line | 5-5 |
| Environment – Speed, Depth, Air and Sea Water Temperature | 5-6 |
| Seawater Temperature Plot Line | 5-6 |
| Estimated Fuel Range | 5-7 |

Navigation/Fuel Information

This Section will give a complete description of the display screens in the **NAV-FUEL** directory of the Diesel View.

Some of the navigation/fuel functions are:

- Navigation screens
- Next waypoint data
- Trip history log
- Depth
- Depth plot line
- Depth, speed, air temperature, and water temperature
- Seawater plot line
- Estimated fuel range

Entering the Navigation/Fuel Directory

To access the **NAV-FUEL** directory, use the trackpad to highlight the **NAV/FUEL** directory from the menu choice. Press **SELECT** to accept and to open the directory.

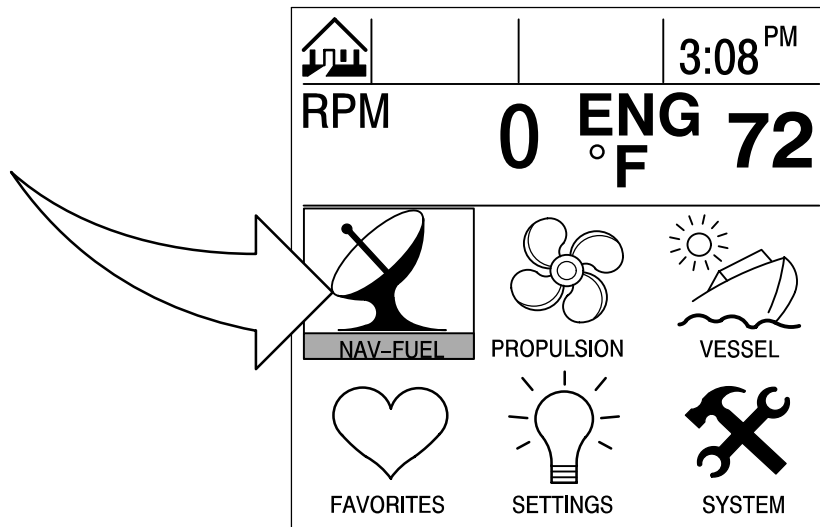

Navigation/Fuel Data Screens

Navigation Screens

IMPORTANT: This device is intended as a navigation aid and should not take the place of paper charts. A careful navigator never relies on one method to obtain position information.

NOTE: For use of the navigation screens, your vessel must include a GPS receiver with NMEA 0183 V1.5 or V2.0+ output and be connected to the Diesel View.

The Diesel View features two different navigation screens: Vessel Course and Next Waypoint Data. Next Waypoint Data provides course guidance to a destination waypoint, if programmed into your GPS navigation electronics.

SCREEN # 1 – VESSEL COURSE – COURSE UP

This vessel course – course up screen has a rotating compass ring that not only shows your direction of travel, but also the direction to a targeted waypoint. When you are not navigating to a waypoint, the compass will show your direction of travel. The boat pointer in the center of the compass ring shows current direction.

When a waypoint is set using a separate GPS unit, an X mark will appear on the compass ring. This X mark will indicate your waypoint. For instance, if the X mark lines up with the center of the boat pointer, you are going directly to the waypoint. If the boat pointer does not line up with the X mark, steer toward the X mark until it lines up with the center of the boat pointer– then continue in this direction until you reach your current target waypoint.

The middle of the compass shows the current cross track error (XTE). This is the distance you are off-course relative to the desired course.

Anytime a compatible GPS is connected, the current Speed Over Ground (SOG) as well as the Course Over Ground (COG) are displayed on the screen.

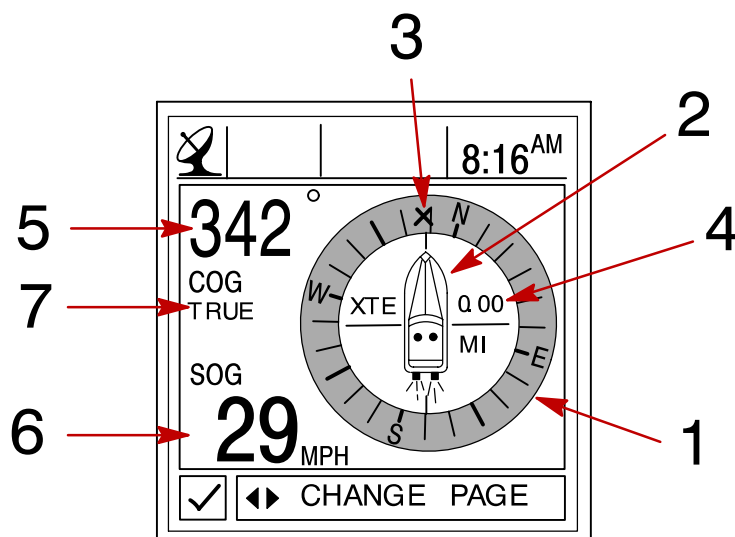

- 1 - Compass ring
- 2 - Boat pointer
- 3 - X – Mark (Gives the Direction to Steer)
- 4 - Cross track error
- 5 - Course over ground (COG)
- 6 - Speed over ground (SOG)
- 7 - GPS Heading – True or Magnetic – Refer to “Settings/Preference/GPS Heading” Menu in Section 6

Navigation/Fuel Data Screens

Navigation Screens

SCREEN # 2 – NEXT WAYPOINT DATA

When navigating to a waypoint, this screen will give you the following navigation information:

1. **DIST TO GO** – Remaining distance to the next waypoint.
2. **TIME TO GO** – Is the time that it will take to reach your waypoint at your present speed.
3. **FUEL TO GO** – Is the fuel it will take to get to your waypoint.
4. **SPD TO WPT** – Is the speed you are making towards your waypoint.

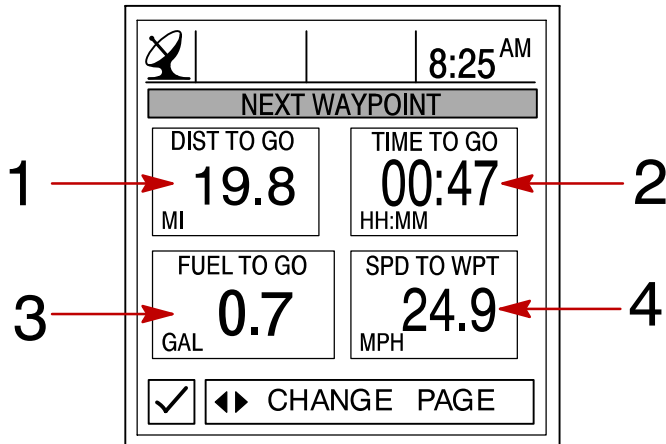

Trip History Log

This screen tracks your boat’s progress since last reset. Displays average fuel economy, average boat speed, total drive time, along with a corresponding distance traveled and fuel used.

To **Reset** trip history log, press and hold down **SELECT** for 5 seconds.

1. Displays the average distance per U.S. gallon or liter of fuel since the unit was last reset.
2. Displays the average speed of the boat since the unit was last reset.
3. Displays the time in hours of the engine usage since the unit was last reset.
4. Displays the total distance traveled since the unit was last reset.
5. Displays the total fuel used since the unit was last reset.

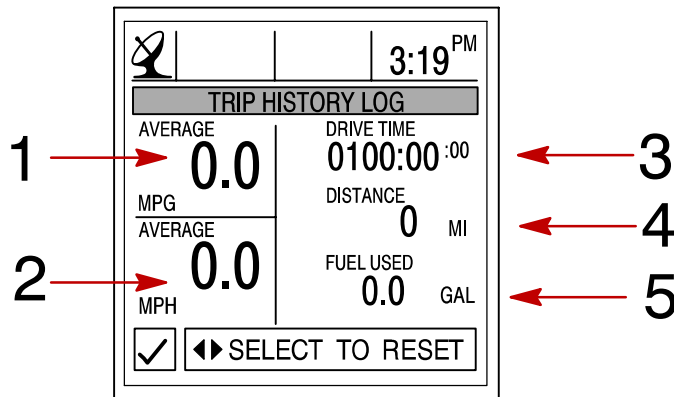

Navigation/Fuel Data Screens

Depth

DEPTH displays the depth of water.

NOTE: To set depth and shallow water alarm levels, refer to "Settings/Sensors" Menu in Section 6.

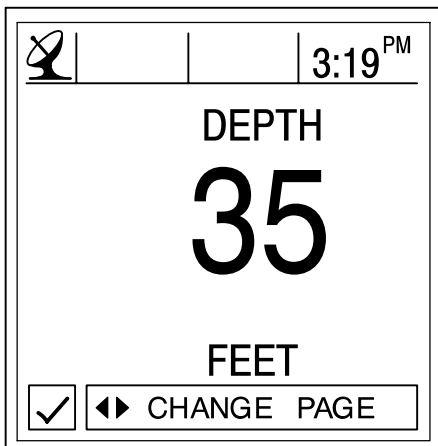

Depth Plot Line

DEPTH PLOT displays a plot of depth vs. time as recorded over the last 16 seconds.

NOTE: To set depth and shallow water alarm levels, refer to "Settings/Sensors" Menu in Section 6.

1. Displays depth plot line.
2. Displays current water depth.
3. Displays low water alarm setting.

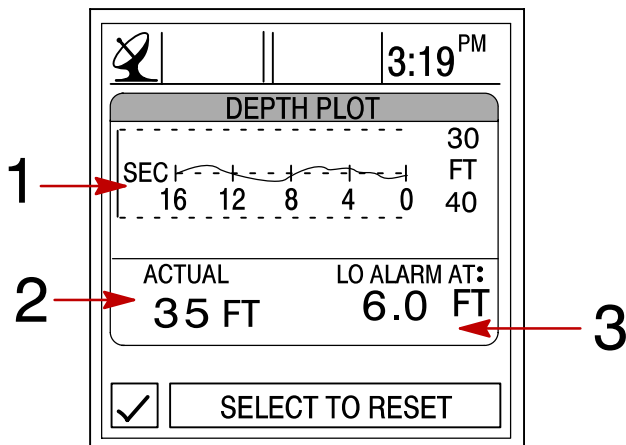

Navigation/Fuel Data Screens

Environment

This screen displays speed, depth, air, and sea water temperature.

1. Displays depth of water.
2. Displays speed of the boat.
3. Displays the air temperature.
4. Displays the sea water temperature.

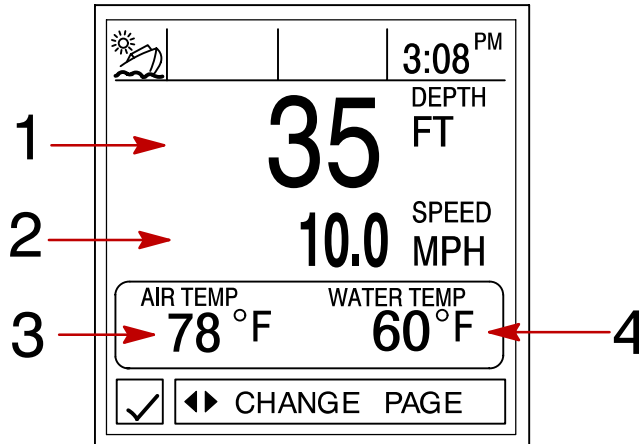

Seawater Temperature Plot

SEAWATER TEMP PLOT displays a plot of seawater temperature vs. time as recorded over the last 80 seconds. Also displays the current water temperature.

1. Displays sea water plot line.
2. Displays current water temperature.

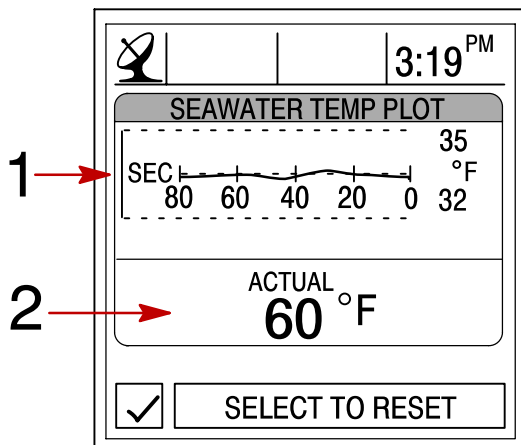

Navigation/Fuel Data Screens

Estimated Fuel Range

ESTIMATED FUEL RANGE displays estimated range and fuel remaining, as well as current total fuel flow.

1. The estimated fuel range is based on boat speed, fuel consumption, and fuel remaining in the tank. The number displayed indicates an estimate of the distance you can travel on the remaining fuel. Speed input required (paddle wheel, pitot pressure, or GPS).
2. Displays the current vessel fuel consumption in U.S. gallons per hour or liters per hour.
3. Displays amount of fuel remaining.

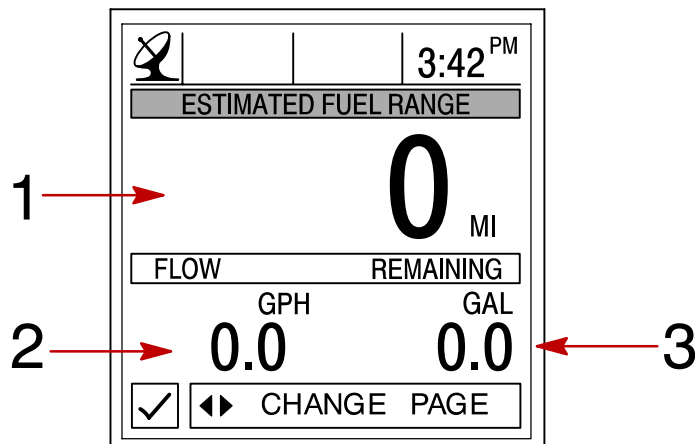

SETTINGS

Section 6

Table of Contents

| | |
|---------------------------------------|-----|
| Settings Information | 6-2 |
| Entering the Settings Directory | 6-2 |
| Settings Directory | 6-2 |
| Settings Options | 6-3 |
| Contrast/Lighting/Clock | 6-3 |
| Units/Language/Offsets | 6-4 |
| Home Page Data | 6-5 |
| Sensors | 6-6 |
| Preferences | 6-7 |
| Favorites/Page Status | 6-8 |

SETTINGS

Settings Information

This Section will give a complete description of the Settings screens in the **SETTINGS** directory of the Diesel View.

In this Section you can configure your Diesel View to display the information the way you prefer.

Some of the Settings functions are:

- Customizing the home page data
- Contrast/Lighting/Clock
- Units/Language/Offsets
- Sensor settings
- Favorites/Page status

Entering the Settings Directory

To access the **SETTINGS** directory, use the trackpad to highlight the **SETTINGS** directory from the menu choice. Press **SELECT** to accept and to open the directory screen.

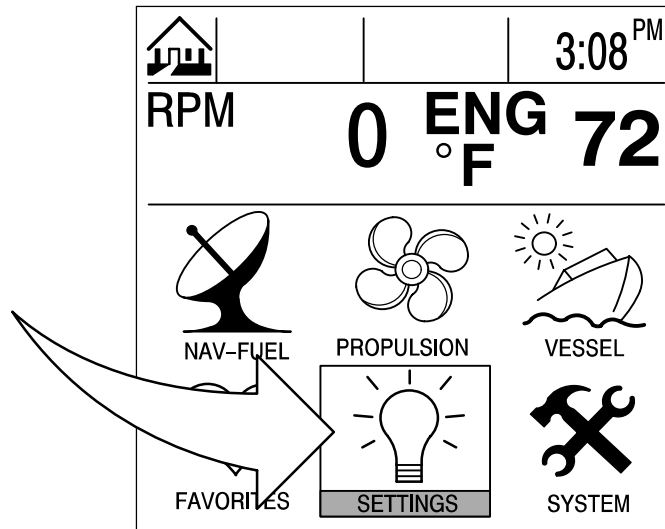

Settings Directory

Settings Directory Screen

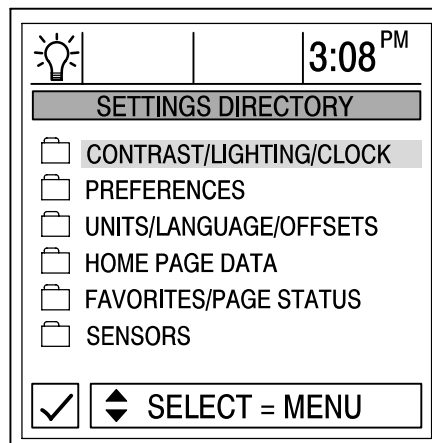

Settings Options

Contrast/Lighting/Clock

To adjust a setting:

1. Press ▲▼ to highlight the desired menu selection.
2. Press ◀▶ to edit the menu box.
3. Press **SELECT** to accept settings.

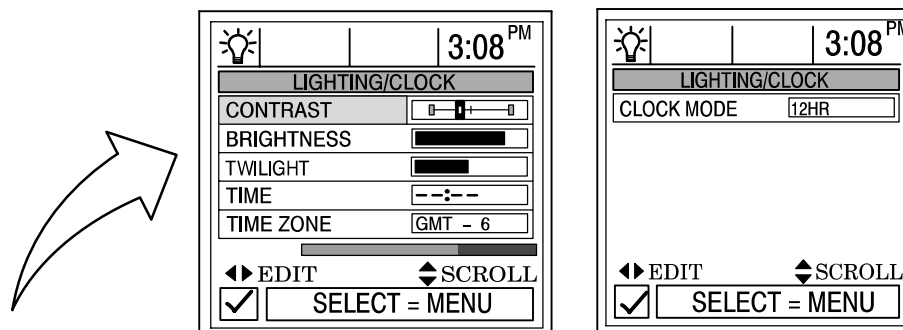

- CONTRAST** – Provides a slide bar to adjust the display screen contrast to compensate for changes in temperature or lighting conditions.
- BRIGHTNESS** – Provides a slide bar to adjust the display screen lighting level.
- TWILIGHT** – The twilight setting is a light sensor setting that adjusts the amount of light needed to automatically turn on the Diesel View backlighting and the System Link gauge lighting. You can manually control when the backlighting turns on by adjusting the slide bar.
- TIME** – If no GPS is connected, press the horizontal arrows to set the current time. If GPS is connected, follow time zone setting below.
- TIME ZONE** – Time zone setting is how many hours you are behind or ahead of Greenwich Mean Time (GMT). The chart below gives approximate GMT time zone settings for various longitudinal zones. Add one hour to the setting for daylight savings time.
- CLOCK MODE** – Select 12 hour or 24 hour clock set.

| Longitudinal Zone | Time Zone Setting | DayLight Saving Time Zone Setting | Longitudinal Zone | Time Zone Setting | DayLight Saving Time Zone Setting |
|---|-------------------|-----------------------------------|--------------------|-------------------|-----------------------------------|
| W180.0° to W172.5° | -12 | -11 | E007.5° to E022.5° | +1 | +2 |
| W172.5° to W157.5° | -11 | -10 | E022.5° to E037.5° | +2 | +3 |
| W157.5° to W142.5° | -10 | -9 | E037.5° to E052.5° | +3 | +4 |
| W142.5° to W127.5° | -9 | -8 | E052.5° to E067.5° | +4 | +5 |
| W127.5° to W112.5° (Pacific Standard Time) | -8 | -7 | E067.5° to E083.5° | +5 | +6 |
| W112.5° to W097.5° (Mountain Standard Time) | -7 | -6 | E082.5° to E097.5° | +6 | +7 |
| W097.5° to W082.5° (Central Standard Time) | -6 | -5 | E097.5° to E112.5° | +7 | +8 |
| W082.5° to W067.5° (Eastern Standard Time) | -5 | -4 | E112.5° to E127.5° | +8 | +9 |
| W067.5° to W052.5° | -4 | -3 | E127.5° to E142.5° | +9 | +10 |
| W052.5° to W037.5° | -3 | -2 | E142.5° to E157.5° | +10 | +11 |
| W037.5° to W022.5° | -2 | -1 | E157.5° to E172.5° | +11 | +12 |
| W022.5° to W007.5° | -1 | 0 | E172.5° to E180.0° | +12 | +13 |
| W007.5° to E007.5° | 0 | +1 | | | |

Settings Options

Units/Language/Offsets

To adjust a setting:

1. Press ▲▼ to highlight the desired menu selection.
2. Press ◀▶ to edit the menu box.
3. Press **SELECT** to accept settings.

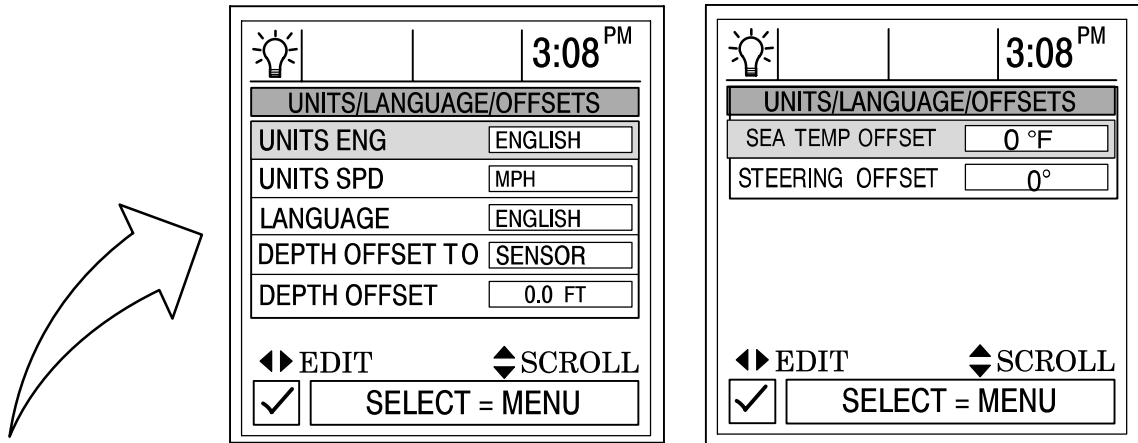

UNITS ENG – Lets you select English or metric format for unit measurements.

UNITS SPD – Lets you select the units at which speed is displayed. You may select from MPH (Miles Per Hour), KM/H (Kilometers Per Hour) or Knots.

LANGUAGE – Diesel View displays only English at this time.

DEPTH OFFSET TO – Normally, this unit measures water depth from the face of the transducer (sensor). Since the transducer is below the water, this distance is not the exact water depth. You can change the depth reading using this depth offset feature. You have three depth offsets selections:

1. **SENSOR** – Will measure water depth from the face of the transducer. No setting to depth offset is necessary.
2. **WATERLINE** – Will give water depth from the surface of the water. You will need to change the depth offset setting below. Measure the distance between the face of the transducer and the water line. Add this measurement into depth offset menu box below.
3. **KEEL** – Will give water depth from the keel of the boat. You will need to change the depth offset setting below. Measure the distance between the transducer and the lowest part of the boat. Place this measurement into depth offset menu box below. This offset will be a negative value.

DEPTH OFFSET – Activate the depth offset feature by adding the measurement taken above to compensate for waterline or keel offset.

SEA TEMP OFFSET – The sea water temperature sensor can be calibrated to match actual sea water temperature. Calculate the different in degrees that the sea water temperature is off and enter it into the menu window.

STEERING OFFSET – The steering sensor can be calibrated to compensate for inaccuracies. Calculate the different in degrees that the steering sensor is off and enter it into the menu window.

Settings Options

Home Page Data

- Look at the **HOME PAGE DATA** and determine if there is any data that you would like to change. Press ▲▼ to select function. Press ◀▶ to edit the function.

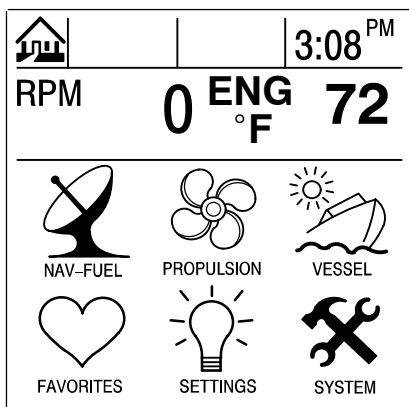
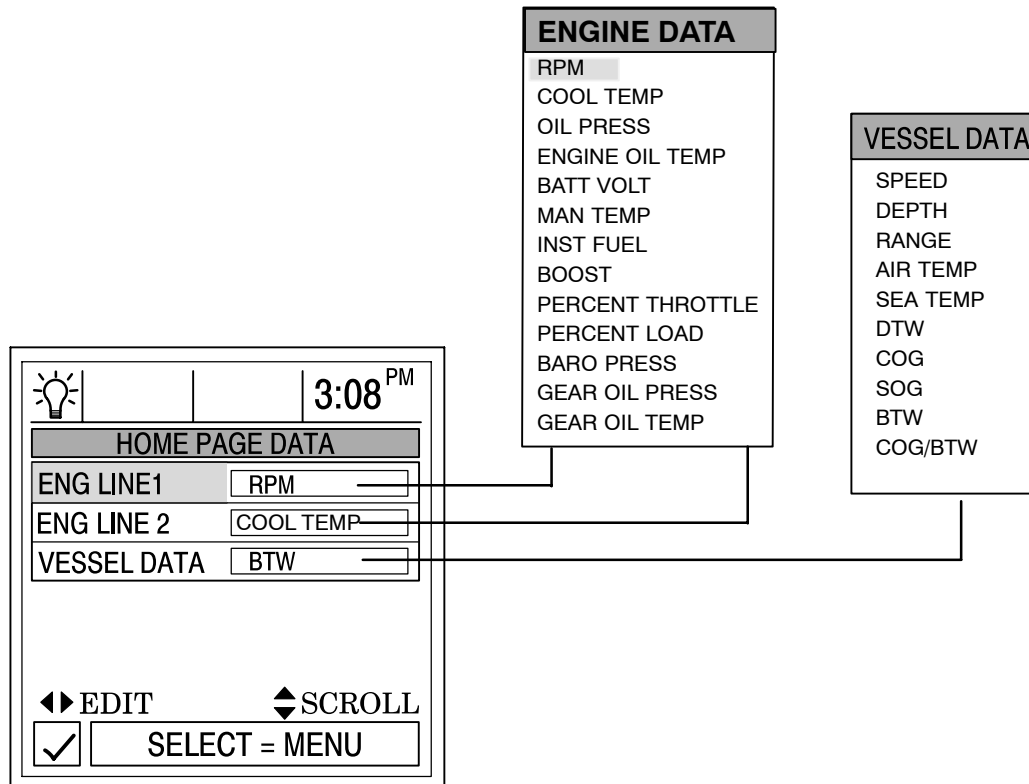

SINGLE ENGINE

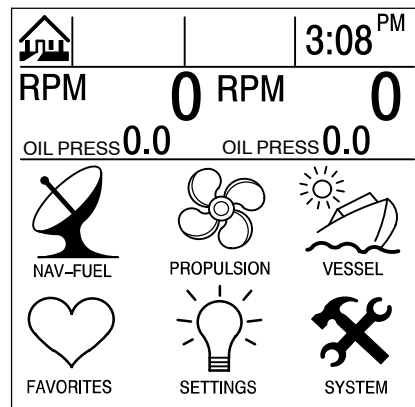

TWIN ENGINE

Settings Options

Sensors

To adjust a setting:

1. Press ▲▼ to highlight the desired menu selection.
2. Press ◀▶ to edit the menu box.
3. Press **SELECT** to accept settings.

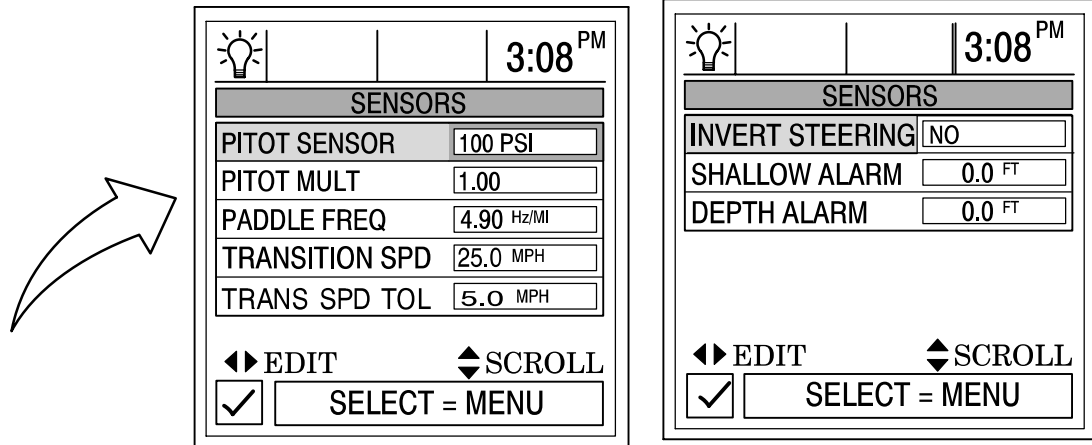

PITOT MULT (Multiplier) – The pitot pressure sensor can be calibrated for correcting display readings that read to high/low. Calculate the percentage that the speed is off and enter it into the menu window.

PADDLE FREQ – Frequency can be changed to match requirements of different sensors. 4.9 Hz per mile or 5.7 Hz per knot is the frequency of the paddle wheel speed sensor provided by Mercury Marine.

TRANSITION SPD – Transition speed is the boat speed at which Diesel View stops looking at the paddle wheel and starts using the pitot or GPS (GPS is priority for high speed if connected) to measure boat speed. Default setting is 25 MPH. If desired, this transition speed can be changed.

TRANS SPD TOL (Transition Speed Tolerance) – Adjust for differences in sensor tolerances between the paddle wheel, GPS, and pitot.

INVERT STEERING – If steering angle displayed is opposite of the direction that it should, the signal can be inverted so the steering angle can be displayed properly.

SHALLOW ALARM – The shallow water alarm can be set to sound a warning at a depth determined by the user. Activate the shallow water alarm by inputting the desired depth into the menu box. The depth range can be from 0.0 – 650.0 feet. Deactivate the shallow alarm by setting the shallow alarm to “0”. For the alarm to operate, the alert horn setting will have to be activated. Refer to “Setting/Preferences” Menu Section 6

DEPTH ALARM – The deep water alarm can be set to sound a warning at a depth determined by the user. Activate the depth alarm by inputting the desired depth into the menu box. The depth range can be from 0.0 – 650.0 feet. Deactivate the depth alarm by setting the depth alarm to “0”. For the alarm to operate, the alert horn setting will have to be activated. Refer to “Setting/Preferences” Menu Section 6

Settings Options

Preferences

To adjust a setting:

1. Press ▲▼ to highlight the desired menu selection.
2. Press ◀▶ to edit the menu box.
3. Press **SELECT** to accept settings.

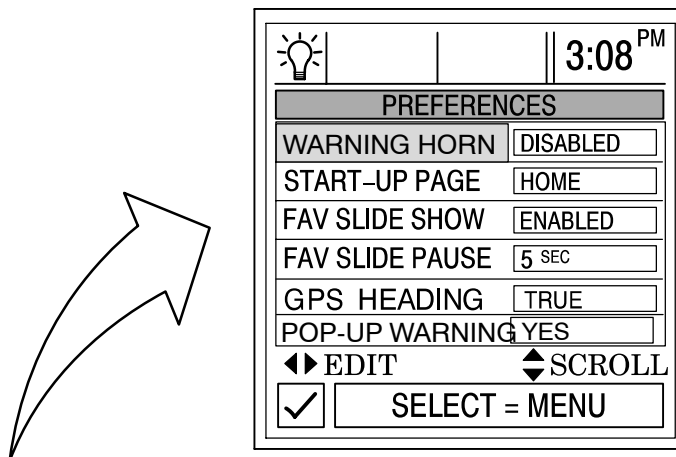

WARNING HORN – The Diesel View has a warning horn alarm. You can set an alarm to sound a warning tone for various fault alarms and shallow or deep water depth warning. To use this alarm, press the right arrow to **ENABLE** the warning horn.

START-UP PAGE – You have two options for what start-up page you want to view. You can select the home page or you can select the last page that’s showing at power off. Press the right arrow to select **HOME** or **LAST PAGE**.

FAVORITE SLIDE SHOW – This feature if desired, will automatically scroll through your selection of favorite screens. This allows the user to view each screen for the pause time selected below. Hold **SELECT** button for 3 seconds to stop the scrolling.

FAVORITE SLIDE PAUSE – Select the pause time you would prefer for viewing each favorite screen in the **Favorite Slide Show**. Select between **5** and **30** seconds.

GPS HEADING – Choose **TRUE** or **MAGNETIC** for the GPS Heading display.

NOTE: To receive BTW in both **TRUE** and **MAGNETIC**, System View must see a valid BWC sentence. If Diesel View sees an RMB sentence, Diesel View will display **TRUE** BTW only.

POP-UP WARNINGS – **ENABLES/DISABLES** the Diesel View pop-up engine fault warnings.

Settings Options

Favorites/Page Status

The favorites/page status allows you to select one of the two following options:

1. Allows you to choose your preferences screens and place them into the **FAVORITES** directory for quick viewing. Screens will still be shown in their respective menus.
2. Allows you to turn off any unwanted screens from all directories in Diesel View.

To adjust a setting:

1. Press ▲▼ to scroll through the list of screens.
2. Press ◀▶ to edit the setting as follows:

♥ Flagging the selected screen with a heart will add the screen to the **FAVORITES** directory. It will also be available in its directory.

✓ Flagging the screen selection with a check mark will turn the screen on in its directory and off in the **FAVORITES** directory.

X Flagging the screen selection with a “X” mark will turn the screen off in its directory and also off in the **FAVORITES** directory.

3:08^{PM}

FAVORITES/PAGE STATUS

| | |
|-------------------|---|
| RPM AND SPEED | ♥ |
| PEAK SPEED AT RPM | ✓ |
| ENGINE DATA | X |
| GEAR DATA | ♥ |

◀▶ EDIT
⬆️ SCROLL

SELECT = MENU

Screen Selections ♥ ✓ X

| | |
|----------------------|--|
| RPM AND SPEED | |
| PEAK SPEED AT RPM | |
| ENGINE DATA | |
| GEAR DATA | |
| MANIFOLD DATA | |
| THROTTLE/LOAD DATA | |
| ENGINE DATA TEXT | |
| STEERING POSITION | |
| TANK STATUS | |
| STBD FUEL | |
| STBD UNUSED | |
| PORT UNUSED #1 | |
| PORT UNUSED #2 | |
| VESSEL STATUS | |
| VESSEL STATUS CONT | |
| ESTIMATED FUEL RANGE | |
| VESSEL COURSE | |
| NEXT WAYPOINT | |
| TRIP HISTORY LOG | |
| DEPTH | |
| DEPTH PLOT | |
| ENVIRONMENT | |
| SEAWATER TEMP PLOT | |

SYSTEM

Section 7

Table of Contents

| | |
|-------------------------------------|------|
| System Information | 7-2 |
| Entering the System Directory | 7-2 |
| System Directory | 7-2 |
| System Calibration | 7-3 |
| Vessel Configuration | 7-4 |
| Tank Configuration | 7-6 |
| Factory Defaults | 7-9 |
| Maintenance Log | 7-10 |
| Active Alarms | 7-11 |
| Alarm History | 7-12 |

SYSTEM

System Information

This Section will give a complete description of the screen settings in the **SYSTEM** directory of the Diesel View.

Some of the system functions are:

- Maintenance log
- Active alarms
- Alarm history
- System calibration

Entering the System Directory

To access the **SYSTEM** directory, use the trackpad to highlight the **SYSTEM** directory from the menu choice. Press **SELECT** to accept and to open the directory.

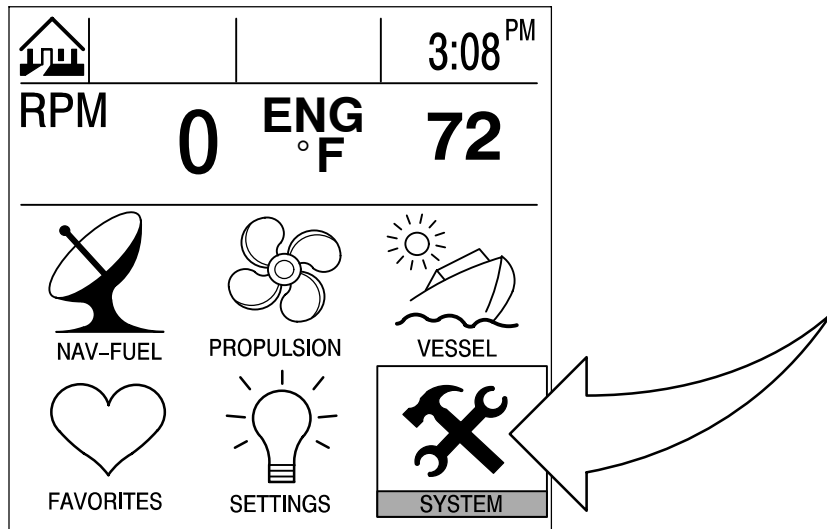

System Directory

System Directory Screen

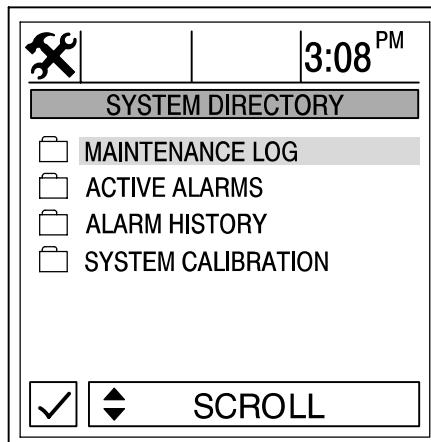

System Calibration

System Calibration

The system calibration consists of the following menus:

- Vessel configuration
- Engine location
- Tank configuration
- Factory defaults

Entering Into System Calibration

IMPORTANT: Entering into the system calibration menus will require you to shut down the engine(s) in order to reactivate the Diesel View.

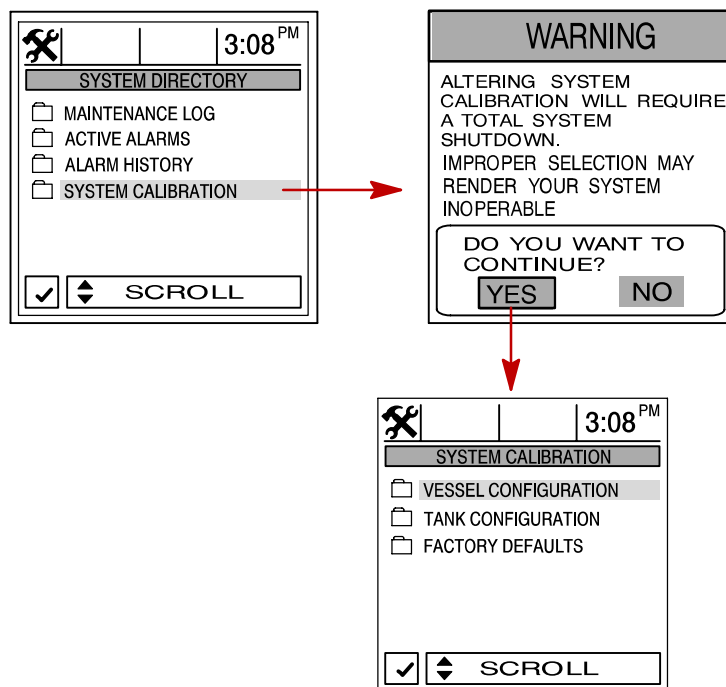

System Calibration

Vessel Configuration

To adjust a setting:

1. Open the **VESSEL CONFIGURATION** menu.
2. Assign **1** for all first station installations (most common choice). Only assign **2** if you are using the Diesel View as a second Diesel View in a dual station installation. Press **SELECT** to continue.

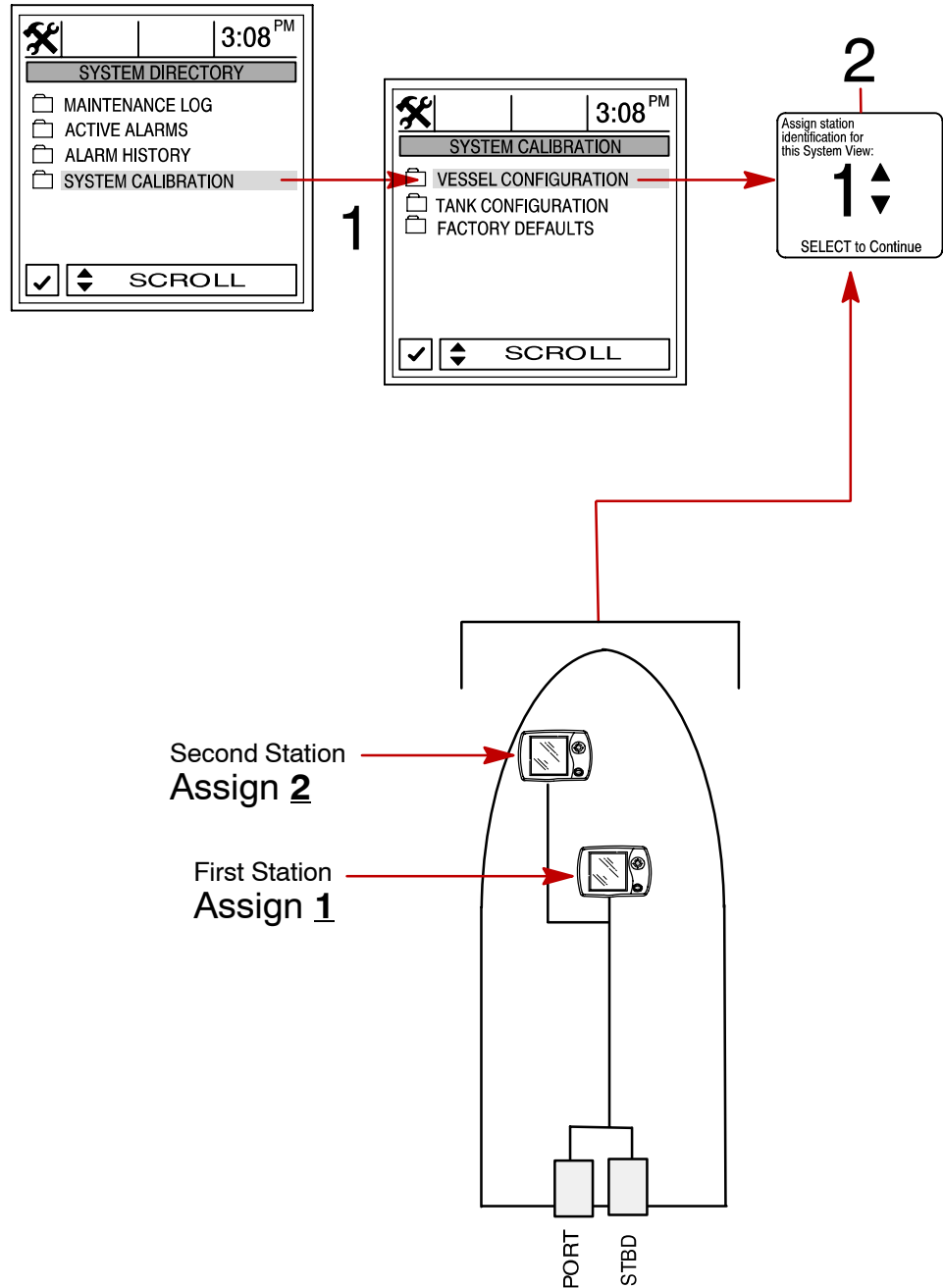

System Calibration

Vessel Configuration (Continued)

NOTE: Single engine applications are required to be configured as STBD engines and addressed as a master engine.

3. Select the engine configuration for the System View. Press **SELECT** to continue.

3

Select the engine configuration for this System View.
SELECT to Continue

| ENGINE | LOCATION |
|--------|----------|
| 1 | STBD |
| 2 | NONE |

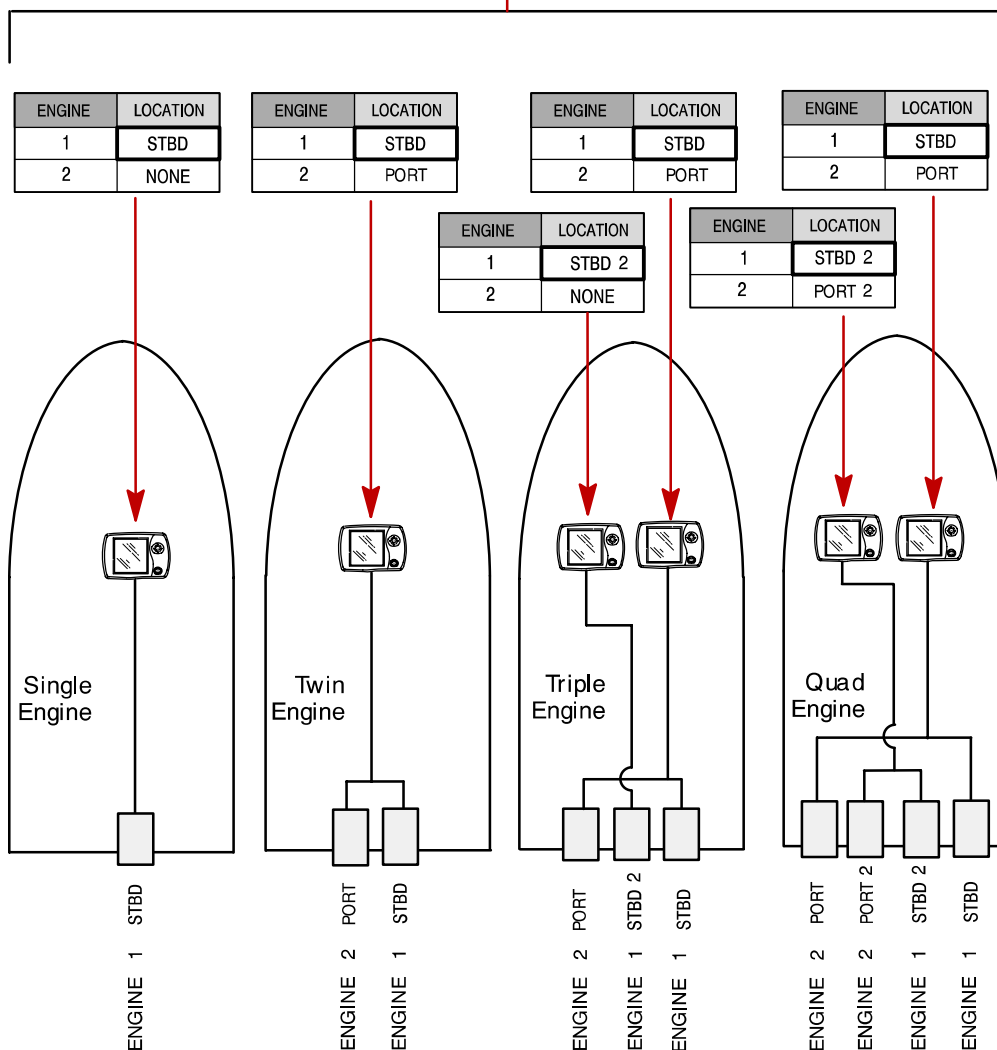

System Calibration

Vessel Configuration (Continued)

IMPORTANT: When configuring engines in Diesel View applications, this is done by setting the engine source addresses with the use of Multi Unit Synchronization (MUS) jumper plugs attached to the OEM harness located on the engine. These jumper plugs set the address of the data being transmitted from the engine(s) to the Diesel View. There are four different addresses available supporting installations up to four engines. For a detailed process for configuration of the engine address jumpers refer to Marine Application Bulletin (MAB 0.15.00 – 08/04/2003) available on the Cummins Marine database.

System Calibration

Tank Configuration

NOTE: Diesel View allows you to choose the name of the tanks you want to appear on the screen. You can choose two tanks per engine.

1. If you would like to change the name of the tank(s), highlight the tank you would like to change. Press ◀▶ to display the list of names of available tank types. Select a name. Press **SELECT** to continue.
2. Enter the capacity of the tanks. Select the tank and press ◀▶ to enter the tank capacity. Press **SELECT** to continue.

TANK CONFIGURATION

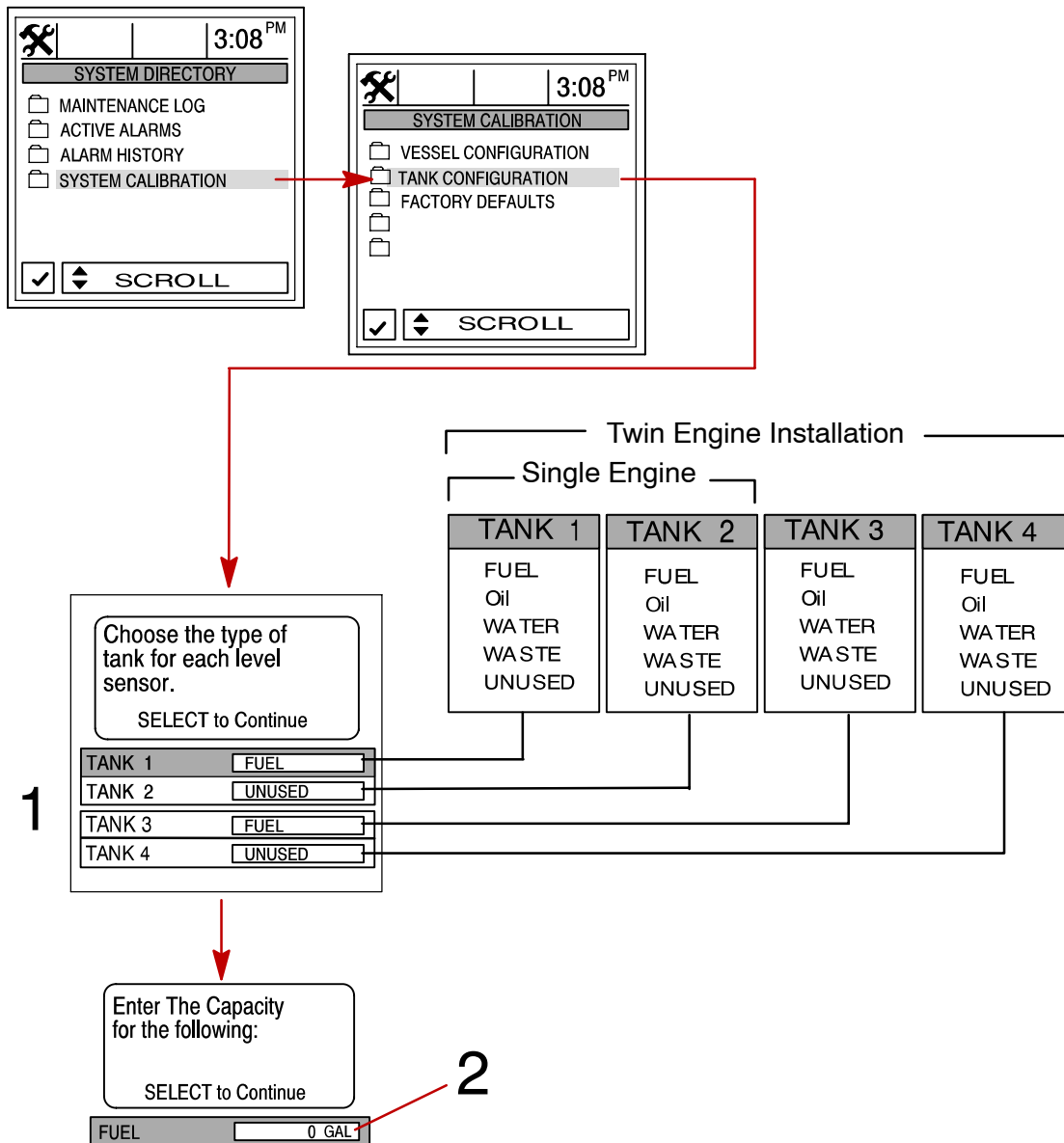

System Calibration

Tank Configuration (Continued)

NOTE: The fuel tank will have to be calibrated in order for Diesel View to display fuel range.

- 3. There are two methods for calibrating fuel tank level:
 - a. **Method 1** – Select **DEFAULT** – The Diesel View will automatically supply an estimated range value based on default sensor values. This mode does not factor in irregular tank shapes. Press **SELECT** to save.
 - b. **Method 2** – Select **ADD FUEL** – This method requires adding fuel at certain calibration points. Diesel View will display an estimated range value that factors in the tank shape.

NOTE: You will have to start with an empty fuel tank and manually fill the tank to the values given per instruction.

- 4. If using **Method 2**, add fuel as shown in illustration below.

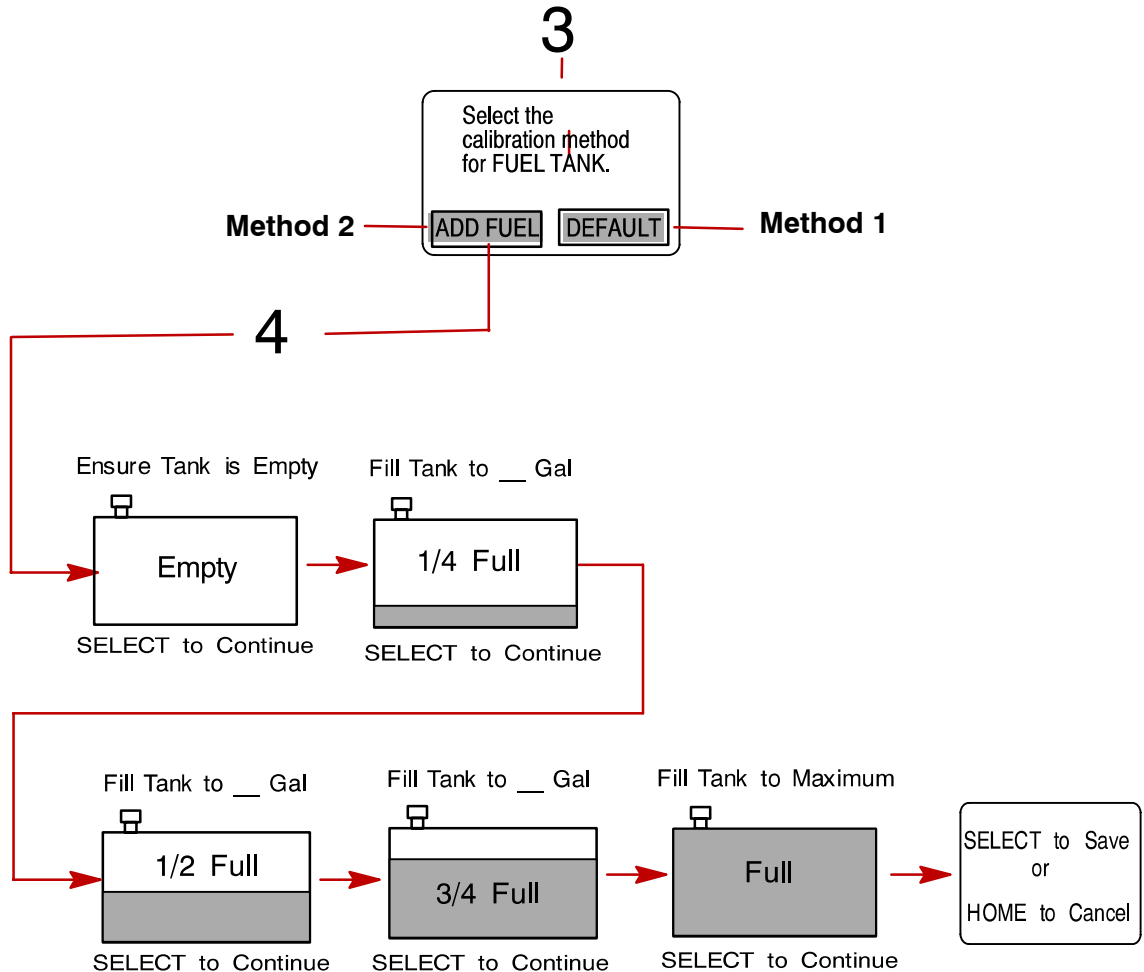

System Calibration

Factory Defaults

RESET SETTINGS DIRECTORY

Restores all settings back to Diesel View's original setup values.

To restore settings back to original setup values:

1. Open **FACTORY DEFAULTS** menu.
2. Press ▲▼ to highlight **RESET SETTINGS DIRECTORY** selection.
3. Select **YES** to reset or **NO** if you want to cancel.

RESET SENSOR DETECTION

At first power up, the Diesel View will automatically detect all the sensors connected to it. If you would like the Diesel View to re-start this sensor detection process over again, use the following procedure.

To reset sensor detection:

4. Open **FACTORY DEFAULTS** menu.
5. Press ▲▼ to highlight **RESET SENSOR DETECTION** selection.
6. Select **YES** to reset or **NO** if you want to cancel.

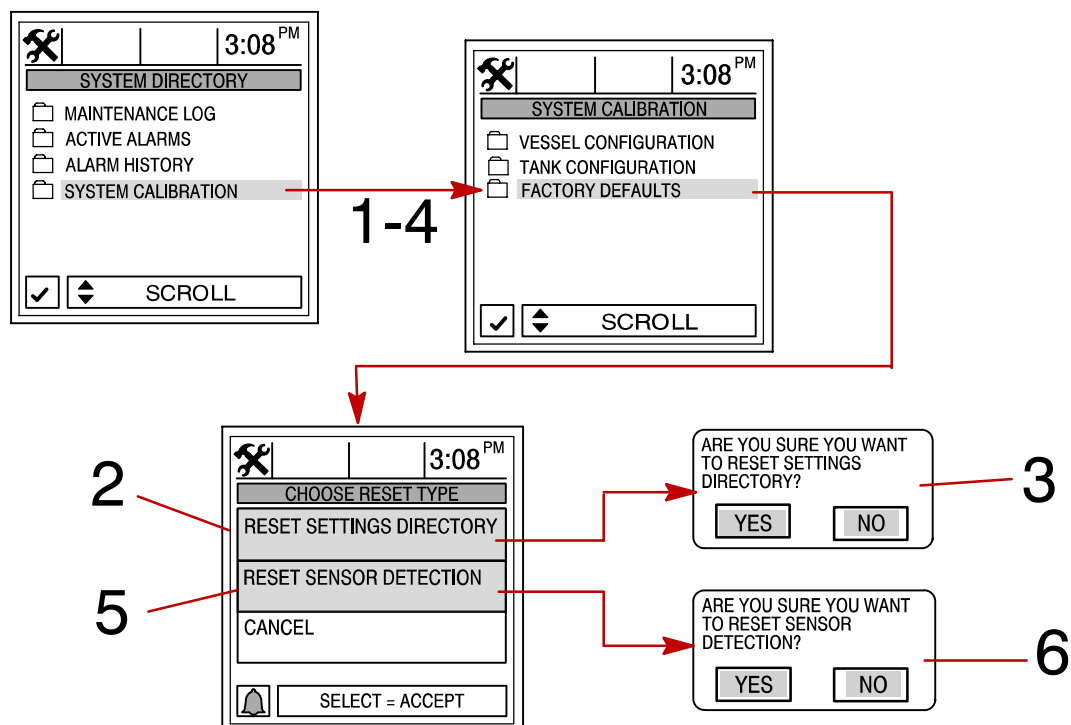

Maintenance Log

Maintenance Log

RECORDING RUN TIME

The maintenance log allows you to record the current engine run time at each service interval. Service intervals should be performed at the time periods specified in your *Engine Operation, Maintenance Manual*.

Recording engine run time at maintenance intervals:

1. Open the **MAINTENANCE LOG** directory.
2. Use the trackpad to select the desired **RUN-TIME** interval box. The engine run time in the box you selected will be blinking. If this is the desired interval you want to record current engine run time, press **SELECT** to save. If you are trying to overwrite a previously recorded interval, you will be asked to confirm your intent.

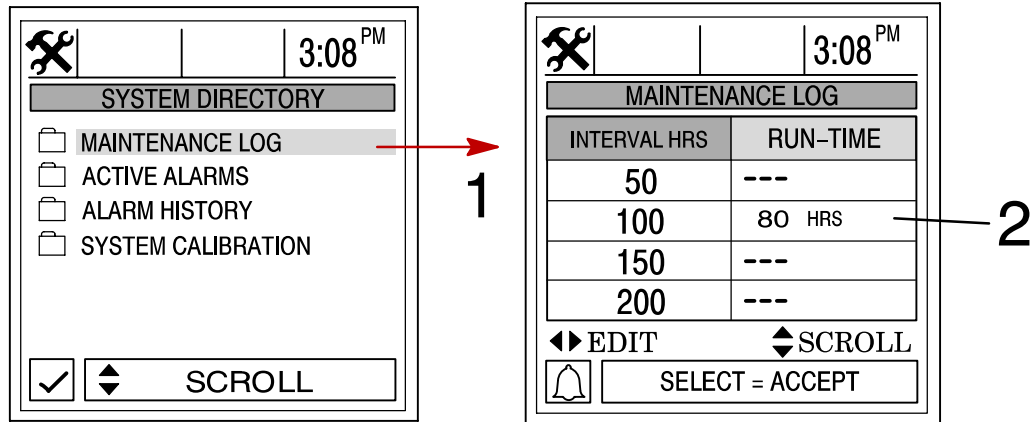

Active Alarms

Active Alarms

The **ACTIVE ALARMS** screen displays all active alarms. The active alarm message will alert the operator to the potential problem.

When a problem is detected with the system, the Diesel View will alert the operator to the potential problem by displaying the alarm data in the information window, located at the bottom of the view screen. Refer to Section 3 of this manual for detailed information on fault conditions and initial corrective action.

To view active alarms:

1. Open the **ACTIVE ALARMS** directory. The directory will display all active alarms.

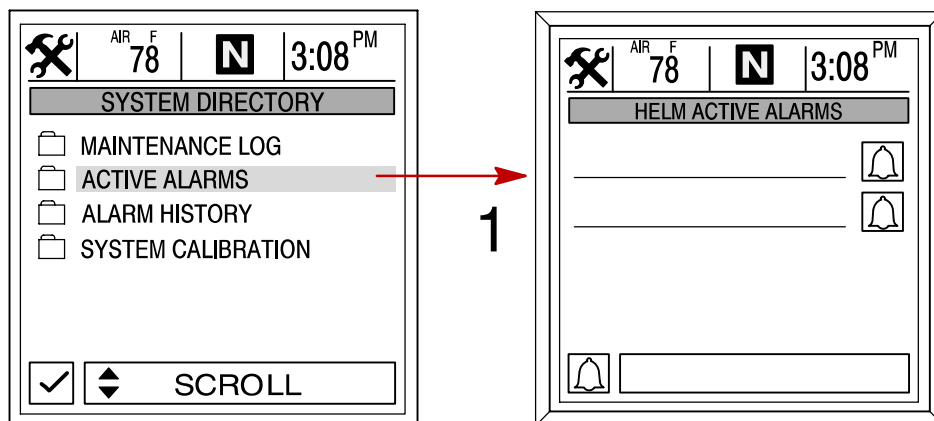

Alarm History

Alarm History

The **ALARM HISTORY** displays all alarms that are, or have been active since last engine key-up.

To view alarm history:

1. Open the **ALARM HISTORY** directory. The directory will display alarm history.

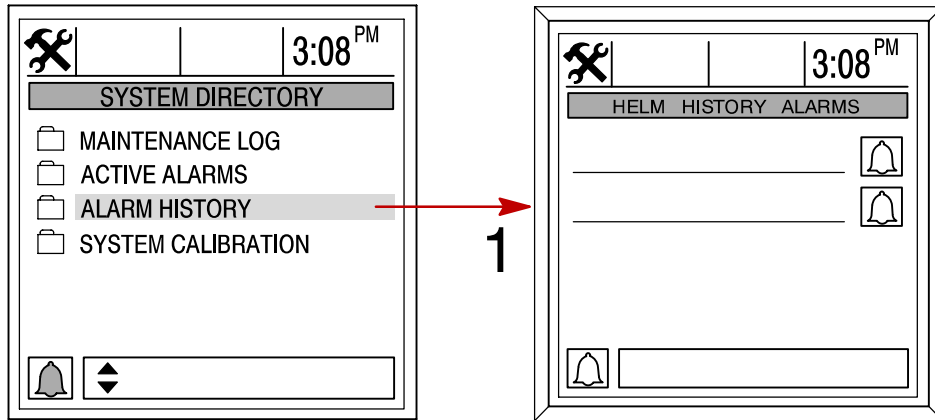

INSTALLATION

Section 8

Table of Contents

| | |
|---|-----|
| Components | 8-2 |
| Special Instructions | 8-2 |
| Installation Information | 8-2 |
| Diesel View Installation | 8-3 |
| Wiring Information for SmartCraft | 8-5 |
| Requirements | 8-5 |
| Installation Guidelines | 8-5 |
| Connecting Optional GPS Unit to the System View | 8-5 |

SYSTEM VIEW INSTALLATION

Components :

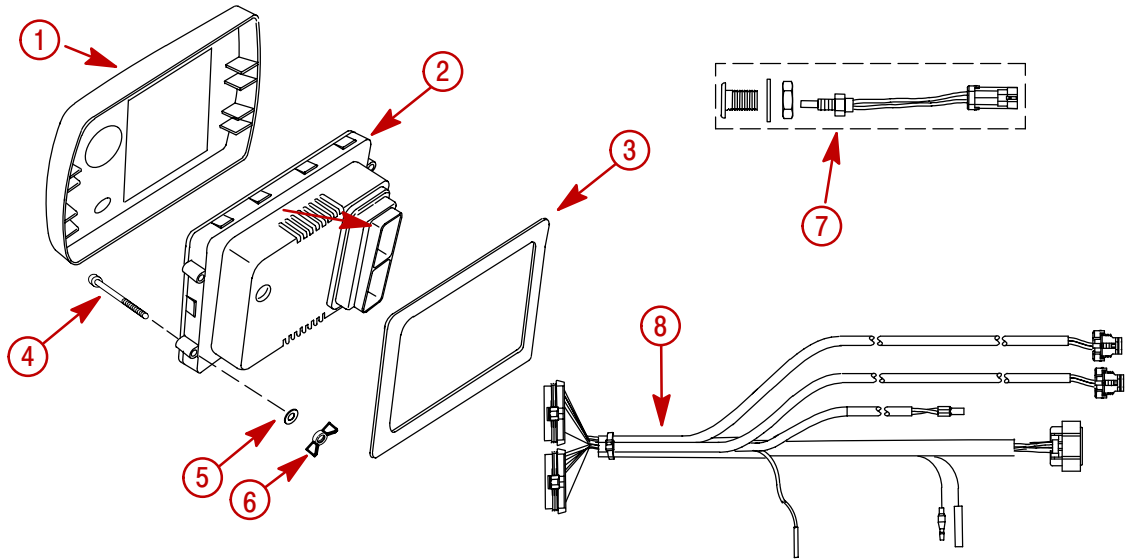

| | | |
|---|---|---|
| 1 | Cover | 1 |
| 2 | Diesel View | 1 |
| 3 | Seal | 1 |
| 4 | Screw | 4 |
| 5 | Flat Washer | 4 |
| 6 | Wing nut | 4 |
| 7 | Outside Air Temperature Sensor Assembly | 1 |
| 8 | Display Harness | 1 |

Special Instructions

The Diesel View display has been designed and tested to operate in environments typically found in marine applications. While the display itself is capable of operating properly in direct sunlight while being exposed to potentially extreme environmental conditions, it is recommended that the display be mounted in a location that minimizes this exposure. See MAB No. 0.15.00 – 08/04/2003 for specific details on the mounting considerations for the Diesel View display.

Installation Information

⚠ WARNING

Be sure to verify both engine key switches are turned off prior to installation.

Before cutting any holes, check area behind dashboard for obstructions (braces, cables, wiring, etc.)

CUTTING TIPS

Fiberglass – Apply masking tape to area to be cut to prevent dashboard from cracking.

Vinyl Covered – Remove vinyl from area to be cut with razor blade to keep vinyl from tearing.

Diesel View Installation

1. Select a location for the Diesel View that affords good visibility and accessibility from behind dashboard.
2. Cut out mounting hole to the given dimensions.

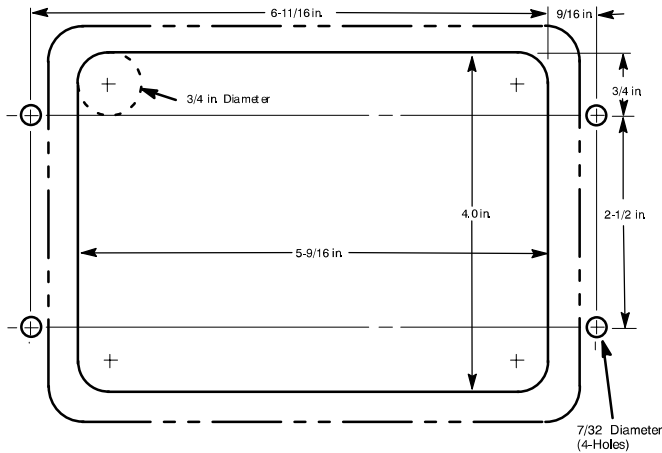

Metric Conversion

| | | |
|---------|---|-----------|
| 7/32 | = | 5 mm |
| 1/2 | = | 12.7 mm |
| 9/16 | = | 14.4 mm |
| 3/4 | = | 19.0 mm |
| 2-1/2 | = | 63.5 mm |
| 4.0 | = | 101.6 mm |
| 5-9/16 | = | 141.2 mm |
| 6-11/16 | = | 169.67 mm |

3. Place Diesel View along with seal into dashboard and secure with 4 screws.

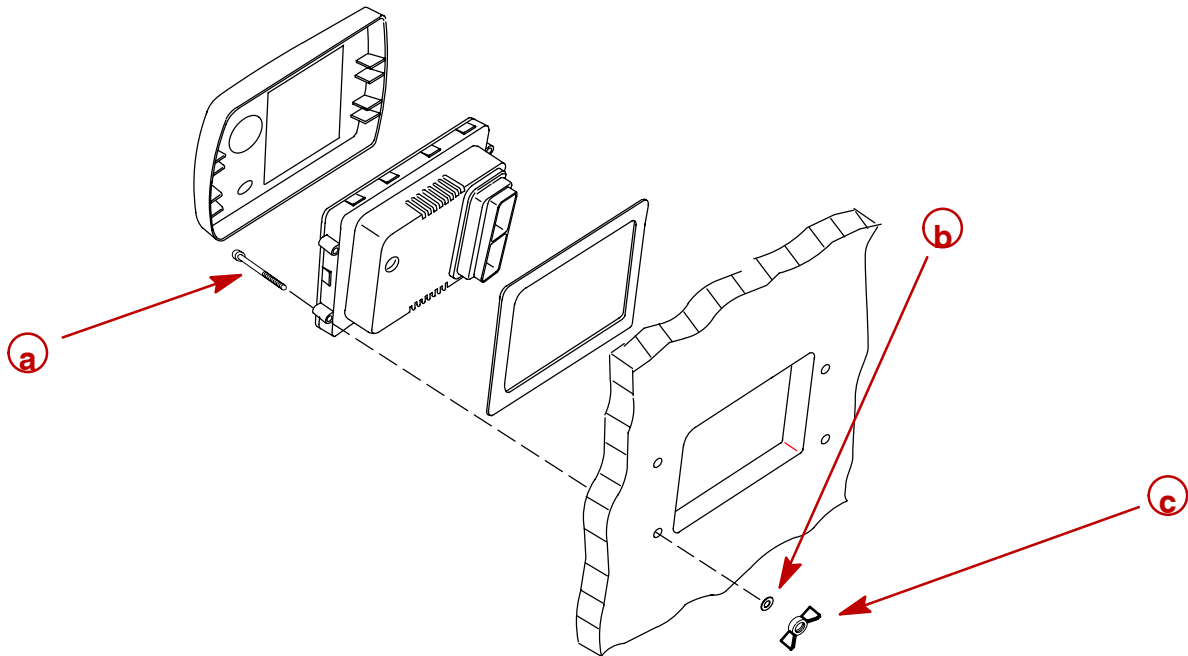

- a** - Screw (4)
- b** - Flat washer (4)
- c** - Wing nut (4)

INSTALLATION

4. Install the outside air temperature sensor as follows:
 - a. Mount the sensor where it will be exposed to outside air and will not be in direct sunlight.
 - b. Select a location and drill a 3/4 in. (19.0 mm) mounting hole.
 - c. Install the mounting adaptor as shown.
 - d. Thread the air temperature sensor into the mounting adaptor.

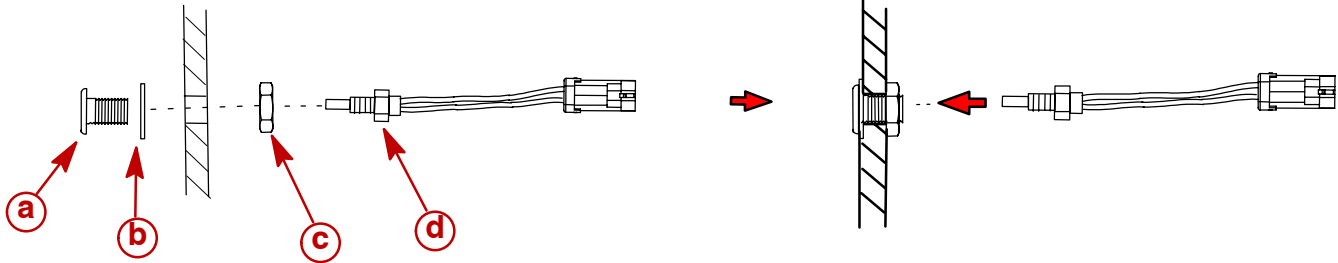

- a** - Mounting Adaptor
- b** - Gasket
- c** - Nylon Nut
- d** - Air Temperature Sensor

Wiring Information for SmartCraft

REQUIREMENTS

SmartCraft communications are via the Controller Area Network (CAN), electrically implemented on a twisted pair of wires. signals. Note: SmartCraft harnesses include other signals besides CAN.

The maximum distance between any two modules on the SmartCraft bus is 130 ft (40 meters). This distance is calculated as the total harness length between the modules (trunk length plus drop lengths).

All interconnect wiring is provided as optioned by Cummins Mercruiser Diesel. It is not recommended that the installer use 'custom made' harnessing for connections in the SmartCraft system.

INSTALLATION GUIDELINES

SmartCraft installations should use only options released by Cummins Mercruiser Diesel.

For detailed installation drawings and installation / application guidelines, refer to the following published documentation.

Marine Application Bulletin (MAB) No. 0.15.00 – 08/04/2003

SmartCraft Marine Application Bulletin

SmartCraft System Specification and Installation Guidelines

Drawing # 3970189

Connecting Optional GPS Unit to the System View

NOTE: *The GPS unit must comply to the National Marine Electronic Association NMEA 0183 Interface Standard V1.5, V2.0+ or later compatible version.*

First, look at the GPS wiring diagram and determine what two leads are the GPS output leads. Locate the White and Blue wires coming from the System View display harness (see Wiring). Connect the GPS output leads to the white and blue wires. If no data is received, switch the wire connections around. If no data is still received, refer the GPS owner's manual and see if the GPS had to be calibrated to turn on the output signal or needs to be grounded differently.

NOTES:

INDEX

Section 9

| | | |
|---|------|--|
| A | | |
| Alarms– Active | 7-11 | |
| Air Temperature | 5-6 | |
| Alarm History | 7-11 | |
| Alarm Message Screens | 2-9 | |
| Alert Horn Mute | 6-7 | |
| B | | |
| Boat Speed | 5-6 | |
| Brightness | 6-3 | |
| C | | |
| Clock Settings | 6-3 | |
| Connecting GPS Unit to the System View | 8-5 | |
| Contrast | 6-3 | |
| D | | |
| Data Display Screen | 2-5 | |
| Depth | 5-5 | |
| Depth Alarm | 6-6 | |
| Depth Offset | 6-4 | |
| Depth Plot Line | 5-5 | |
| Display Screens | 2-2 | |
| E | | |
| Engine Data Screens | 3-4 | |
| Engine Fault Information | 7-5 | |
| Engine Location | 7-5 | |
| Engine RPM Synchronizer | 3-4 | |
| Engine RPM/Speed | 3-3 | |
| Environment | 5-6 | |
| F | | |
| Favorite Page Screen Selection | 6-8 | |
| Favorite Page Status | 6-8 | |
| Favorite Slide Pause Setting | 6-7 | |
| Favorite Slide Show Option | 6-7 | |
| Fuel Flow | 5-7 | |
| Fuel Range | 5-7 | |
| Fuel Remaining | 5-7 | |
| Fuel Tanks | 4-4 | |
| G | | |
| GPS Heading Selection | 6-7 | |
| H | | |
| Home Page Data | 6-5 | |
| Home Page Screens | 2-3 | |
| I | | |
| Installation | 8-2 | |
| Invert Steering | 6-6 | |
| K | | |
| Keypad Usage | 1-2 | |
| L | | |
| Language | 6-4 | |
| M | | |
| Maintenance Log | 7-10 | |
| N | | |
| Navigation Screen | 5-3 | |
| Navigation/Fuel Directory | 5-2 | |
| Next Waypoint Data | 5-4 | |
| P | | |
| Paddle Frequency | 6-6 | |
| Peak Speed at RPM | 3-3 | |
| Pilot Multiplier | 6-6 | |
| Pilot Sensor | 6-6 | |
| Preference Settings | 6-7 | |
| Propulsion Directory | 3-2 | |
| R | | |
| Resetting Sensor Detection | 7-9 | |
| Restoring Factory Settings | 7-9 | |
| S | | |
| Seawater Temperature Offset | 6-4 | |
| Seawater Temperature Plot | 5-6 | |
| Sensors | 6-6 | |
| Set–up for Engine Location | 7-5 | |
| Setting Directory | 6-2 | |

INDEX

| | |
|-----------------------------------|-----|
| Settings Information | 6-2 |
| Shallow Alarm | 6-6 |
| Start-up Page Preference | 6-7 |
| Start-up Screens | 2-2 |
| Starting Up the Diesel View | 2-2 |
| Steering Offset | 6-4 |
| Steering Position | 4-3 |
| System Calibration | 7-3 |
| System Directory | 7-2 |
| System Information | 7-2 |

T

| | |
|--|-----|
| Tank Configuration | 7-5 |
| Tank Status | 4-3 |
| Time Settings | 6-3 |
| Transition Speed | 6-6 |
| Trip History Log | 5-4 |
| Setting Troll Control | 3-6 |
| Typical Installation Configuration of the System View | 8-2 |

U

| | |
|---------------------------------|-----|
| Units (English or Metric) | 6-4 |
|---------------------------------|-----|

V

| | |
|------------------------|-----|
| Vessel Course | 5-3 |
| Vessel Directory | 4-2 |
| Vessel Status | 4-5 |

W

| | |
|--------------------------------------|-----|
| Warning Display Screens | 2-9 |
| Water and Waste Tanks | 4-4 |
| Wiring Information for SmartCraft .. | 8-5 |