



Southwire®

Guide for Installation and Use of Southwire C⁷ Overhead Conductor

Introduction

Southwire's C⁷ overhead conductor continues a Southwire tradition of overhead conductors designed with durability and reliability as the first priorities. Southwire's HS285 overhead conductor introduced an ultra-high-strength steel core as a means to improve the sag performance of conductors with steel cores. Southwire's C⁷ conductor family is similarly targeted at high reliability and long service life.

Similar to the case with steel cores, individual carbon fiber composite strands are assembled to offer a core that is more flexible than a large monolithic core. A multi-strand core has the significant advantage of structural redundancy which protects the conductor from catastrophic failure.

C⁷ overhead conductor can be manufactured with a choice of two types of electrical grade aluminum. C⁷ conductor is available with fully-annealed 1350 O-temper electrical-grade aluminum. This conductor is designated Aluminum Conductor Composite Supported (ACCS). ACCS is the best choice for minimizing thermal sag, but may not be suitable for districts with heavy ice and/or storm loads. C⁷ conductor is also available with ZTAL high-temperature aluminum-zirconium alloy. This conductor is designated as (Z) Thermal Aluminum Alloy Conductor Composite Reinforced (ZTACCR). ZTACCR has additional strength and elastic modulus from the aluminum alloy for handling heavy loads with minimal sag.

C⁷ conductor was designed with the crew in mind. Familiar tools, fittings and procedures ensure that crews can be confident in the safety and reliability of the C⁷ conductor family. C⁷ conductor is tough. The multi-strand core brings flexibility and avoids a single-point-of-failure. C⁷ core is stronger than any steel core and only 20% of the weight. The polymers used in C⁷ core strands are used in the most demanding aerospace and chemical industry applications. We can be confident that even chemically-aggressive outdoor environments will not degrade the polymers in the C⁷ core.

It is, however, necessary to recognize that carbon fiber polymer composites are different from metals and may require different handling. The following section contains all of the handling

requirements to ensure the installation is trouble-free. Proper installation will ensure a long service life for the conductor.

Special Precautions

The C⁷ carbon fiber composite core is stronger than even Southwire's ultra-high-strength steel core, HS285. Linear composites like the C⁷ core achieve their superior properties by orienting the strength members, in this case carbon fiber strands, in the same direction as the mechanical load. A steel core strand is strong when loaded in any direction; therefore, it can resist incidental compression and crushing loads during handling and installation. In tension, the C⁷ core is almost 50% stronger than standard steel core. It is also one-fifth of the weight of steel.

Polymer composites do not match the hardness and abuse tolerance associated with steel. A steel core will bend, whereas a composite will resist bending up to the breaking point. Steel is hard, and resists crushing forces much better than a polymer composite. Fortunately, the aluminum outer shell protects the core strands during normal bending and crushing. Common-sense precautions are needed to prevent damage. Handling damage severe enough to damage the core will leave its mark on the aluminum strands, making damage easy to detect should it occur. Two failure modes and the countermeasures are discussed below:

- 1) Excessive bending: a steel strand will kink if it is bent, but it can be straightened with only moderate loss of strength. Each C⁷ core is tested at the factory to ensure it can tolerate bending down to an approximately 20 in diameter circle. Unlike steel strands, C⁷ strands do not yield or kink when bent past a safe diameter. They reach a limit, and then break. The goal during all handling and installation is to keep a safe margin to the breaking point. Handling incidents are largely unavoidable; the most important safety measure is to detect and report any event where the bending limit could have been exceeded.

To ensure a safe margin to any damage threshold, Southwire recommends a finished conductor be placed on a reel with a drum diameter greater than 30 times the conductor diameter. The entrance block and any running angles should use a block with a bottom groove diameter of at least 30x the conductor diameter. For turning angles less than 20°, the sheave bottom groove diameter must be at least 20 times the conductor diameter. On tangent structures, a sheave bottom groove diameter of 20x the conductor diameter minus 4 in (10 cm), is acceptable.



Figure 1: Example of a situation where bending is excessive even for ACSR. In this case, the payout reel is located downslope from the bull wheel, and the conductor bending angle is 35° around a four (4) inch roller. Photo courtesy of Trans Power New Zealand.



Figure 2: A full-size block should be used to avoid excessive bending around small guide rollers. Photo courtesy of Trans Power New Zealand.



Figure 3: Pulling the conductor to ground to install the traveling ground is commonly done using a single rope. This could kink the conductor if tension was high enough. Use a 20x diameter (51 cm) guide roller, or slacken the conductor if it needs to be lowered to install the traveling ground. Photo courtesy of CenterPoint Energy.



Figure 4: It is OK to drape slack conductor across a small roller. This would not be acceptable if the conductor was under tension or if the crew was pulling the tail to install a fitting.



Figure 5: Care should be taken to ensure grips do not bend the conductor. Notice, the tail from the grip is trained at a gentle angle, and tension on the slack side is low to prevent excessive bending.



Figure 6: If the conductor has taken a “set” from bending, the bent section should be cut out and a full tension splice installed. The section shown was bent 90° around a six (6) inch radius. The tensile test showed a 25% strength reduction.

- 2) **Crushing:** steel strands are hard and can resist crushing loads. The resins used in C⁷ conductor are among the toughest available. They can tolerate some abuse, but the resin is softer than hard aluminum strands and if the conductor is crushed, the core can sustain damage. Driving a vehicle across a conductor is an example of abuse that a steel core conductor might survive but will damage a composite core. Similar to the case for

exceeding the bending limits, external damage to the aluminum strands should be visible upon inspection. Damaged sections should be cut out and a full-tension splice installed. Consider sending potentially damaged sections to Southwire for evaluation.

Prior to sagging, the full length of the line should be inspected for any signs of localized bending. Any kink or birdcage must be evaluated. If in doubt, take a photograph and e-mail it to Southwire for evaluation. Handling accidents during transmission line construction are almost unavoidable. What is critical is that damage get reported and repaired before the line is pulled up to sag.

Protected against excessive bending and protected from crushing, C⁷ conductor will outlast a steel core conductor for the reason that steel will eventually corrode, whereas the composite core is immune to all known chemicals in the natural environment. C⁷ conductor can be installed using conventional techniques developed over the past 100 years of conductor installation. IEEE 524, *Guide to the Installation of Overhead Transmission Line Conductors*, is an excellent guide and is endorsed by Southwire for both conventional conductors and C⁷ conductor installation practices. Southwire's installation guides are reviewed to ensure they are compatible with the guidelines in IEEE 524.

Reel Handling and Storage

Unloading equipment must never come in contact with the conductor. Lifting must be performed using a fork lift or crane as described below.

When using a fork lift, the forks shall be placed under both flanges, with the flange facing the operator.

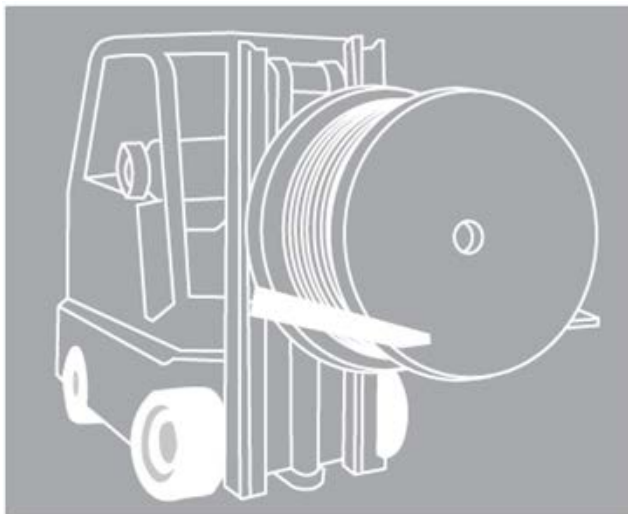

Figure 7: Forklift handling of reels.

When using a crane, a spreader bar must be used in conjunction with either “J” hooks or an axle to prevent damage to the reel flange and conductor. “J” hooks should be placed in the arbor holes. Axles should be inserted through the arbor holes and lifted with straps.

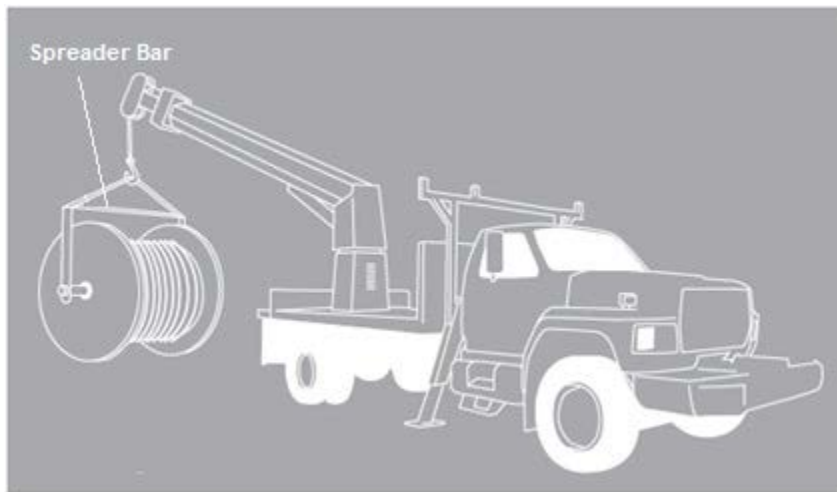

Figure 8: Crane handling of reels.

Reels should be stored away from physical and environmental hazards, such as chemicals. Conductor reels must be stored standing on their flanges in a flat, well-drained area. The conductor must not be allowed to touch the ground.

Conductor Handling

Avoid scuffing the surface of C^7 conductor. C^7 conductor should not be dragged across any surface. Minor abrasions should not be a cause of concern; most can be sanded or buffed out. In an EHV or UHV application, the abrasion should be evaluated for possible corona concerns.

Payoff

The conductor reel should be set up on a reel payoff stationed a minimum of 40-50 feet behind and in line with the bullwheel tensioner. This will ensure that the conductor does not scrub the flanges as it is being unwound.



Figure 9: Payoff and bullwheel setup.

Paying off straight from the reel will help to avoid scuffing of the conductor against adjacent conductor turns or against the reel flange. Proper adjustment of the fairlead roller guides is necessary to prevent scuffing of the conductor as it reeves through the bullwheel. Reels are designed only to transport the conductor; they are not designed for use as tensioning devices. Minimal braking tension should be applied to the payoff to prevent damage to the conductor or reel. Only enough braking tension should be applied to the reel to keep the conductor taut between the reel payoff and tensioner and to prevent the reel from over-rotating when the pulling operation stops. Back tension should not exceed 1000 lb (4.4 kN). If too much back tension is applied, the conductor on the outer layer can “pull down” into the underlying layers, as in Figure 10.



Figure 10: Conductor pulldown.

Bullwheel

Only dual drum multi-groove bullwheel tensioners are recommended for C⁷ conductor. The bullwheel drums may be offset or tilted so that the offset will be approximately one-half the groove spacing.



Figure 11: Dual drum bullwheel, courtesy of ONCOR Power Delivery.

Semicircular grooves with depths of 0.5 or more times the conductor diameter and flare angles of 5-15° from vertical are recommended. For multilayer conductors, the number of grooves in the bullwheel must be sufficient to prevent the outer layer of wires from slipping through underlying layers. The minimum bottom groove diameter of the bullwheel must be 35 times the conductor diameter. Additional sizing charts and diagrams can be found in IEEE Standard 524. Bullwheels must be properly sized and lined to prevent scuffing and damaging of the conductor.

The outer layer of wires on all standard stranded bare overhead aluminum conductors has a right-hand direction of lay. The conductor should be reeved through the bullwheels such that, when facing in the direction of puller, the conductor will enter the bullwheel on the left side and exit from the right. This orientation is necessary to avoid any tendency to loosen the outer layer of strands.

Elastomer- or thermoplastic polymer-lined grooves are recommended to avoid permanent scuffing of the surface of the conductor. Semiconducting linings should not be relied on for grounding purposes.

The bullwheel should be set up in line with the pull and 3-4 times as far from the base of the structure as the height of the entrance block at the first structure. This orientation will provide between a 14-19° angle as the conductor exits the bullwheel and also as it enters the entrance or breakover sheave.

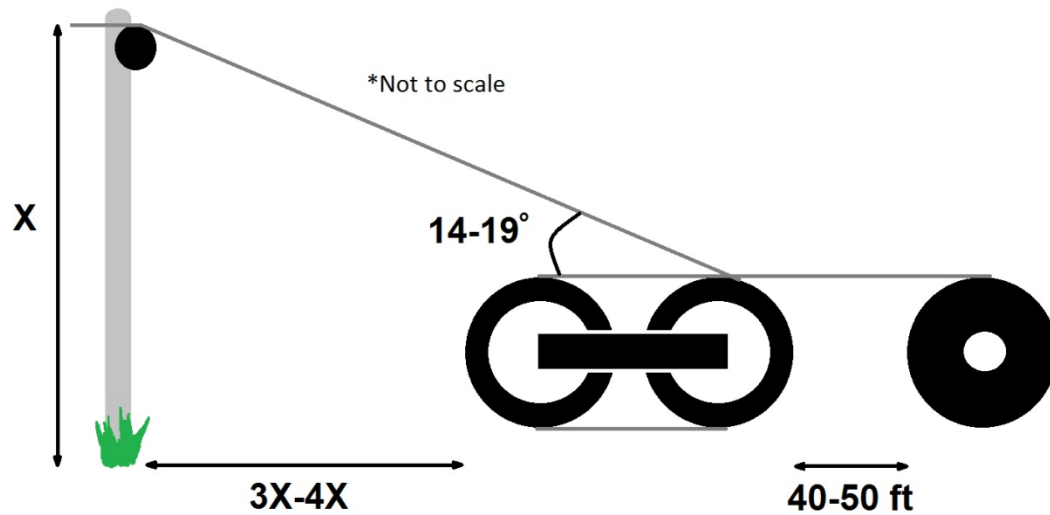

Figure 12: Orientation for bullwheel/payoff setup.

Stringing Sheaves

A minimum bottom groove diameter of 20 times the conductor diameter is recommended for partial turns (less than 20°). For entrance blocks and pulls with a structure offset greater than 20° , this diameter needs to be increased to 30x conductor diameter. For straight line tangent structure blocks, the bottom groove diameter requirement may be relaxed to 20 times the conductor diameter minus 4 in (10 cm). Measurement A in Figure 13 below shows where to measure the bottom groove diameter.

The minimum radius at the base of the groove is recommended to be 1.1 times the radius of the conductor. The location of this measurement is shown as Measurement B in Figure 13. Sheaves with a groove radius as above may, in general, be used with smaller conductors. However, the more layers of aluminum that exist, the more important it is to have a well-fitting groove.

The minimum depth of the groove should be 1.25 times the conductor diameter. This measurement is given as Measurement C in Figure 13. The flare of the grooves should be between $12-20^\circ$ from vertical to facilitate the passage of swivels, grips, etc., and to contain the conductor for angled pulls.

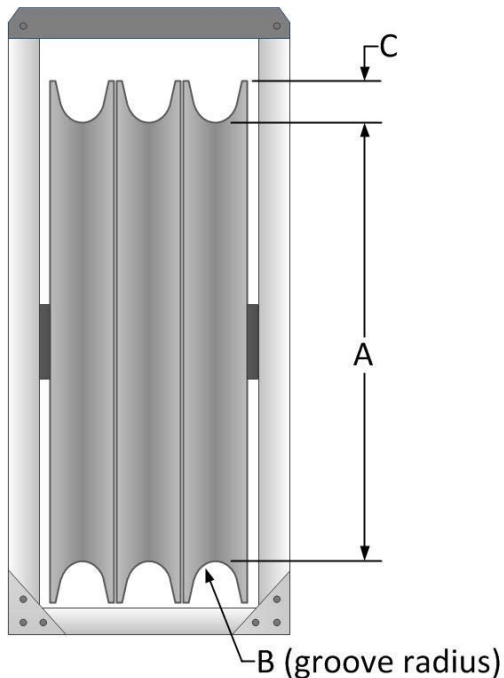

Figure 13: Measurements for stringing sheave.

Sheaves should be lined with neoprene or polypropylene to increase bearing area and protect against scratching of the conductor. Sheaves must be free-wheeling. Rough handling of sheaves can result in inadequate performance, so make sure all sheaves are in proper working order before use.

Running Grounds

Running grounds should be installed along two points in the pull—one between the reel stand or tensioner and first structure, and the other between the puller and last structure. Running grounds should be bonded to the established ground and free-wheeling. They should not be over tightened, as this could cause surface abrasion or birdcaging. Also note the caution about using a rope to pull the conductor down for installation of grounds.

Conductor Stringing and Sagging

To avoid damaging the conductor, tension stringing is recommended. The maximum recommended pulling tension during the stringing operation should not exceed that necessary to maintain clearances above obstructions on the ground or safety structures. Recommended stringing tensions are between 5-10% of the rated breaking strength of the conductor and must never exceed 50% of sagging tensions. Recommended pull speeds are between 2 to 5 mph (5-8 kilometers per hour).

Any conductor that is to be left in the sheaves for an extended period of time can be damaged. Since it is not secured, weather and other factors can cause slack to move from sheltered span

to more exposed spans during times of high wind. Temperature changes can also cause slack to travel across the blocks from the long spans to the short spans and vice-versa. Southwire recommends that any conductor be pulled up to sag and clipped in as soon as possible. IEEE 524 recommends the conductor remain in the stringing block no longer than 72 hours. The attachment points can be marked immediately after sagging if the conductor must be left in the blocks for an extended period of time. If a conductor must be left in the sheaves for an extended period of time, it should be left at a tension less than 50% of sagging tension, close to pulling tension, to prevent creep from affecting the sag values. Upon request, Southwire will recommend creep correction factors if a line was held above 50% of sagging tension for longer than several hours required for clipping in.

Conductor Grips

All grips used for C⁷ must be of the transmission grade. The jaws of transmission grade grips are longer to ensure more gripping area on the conductor. Grip jaws may be round or oval but not V-shaped. Grips must be properly sized for the conductor type, conductor diameter, and tensions to be installed. Range taking grips that accept a range of conductor sizes, e.g. 25 mm to 28 mm, should not be used. Any grip with an off-set in the jaw area should not be used as it could damage the core.

Prior to use, grips must be inspected to ensure they are in good operating condition and tested for holding strength on the conductor to be installed. Southwire recommends taking a section of the conductor to be installed and, using two line trucks as temporary anchors, testing the holding strength of the grips using a chain hoist and dynamometer to verify grip holding strength. During testing, grips should not slip when subjected to a minimum tension of 110% of the working tension during installation. The following grips may be used for C⁷ conductor:

For pulling:

- **Basket Grips:** Also referred to as a Kellems grip, a basket grip is the only acceptable grip for pulling C⁷ conductor. Basket grips must be double-banded on the ends to prevent slipping.



Figure 14: Basket grips.

A swivel is required between the Basket grip and pull line or between grips if multiple reels are tied together (double-socked) for longer pulls. The swivel will allow the conductor to rotate freely during the pulling process.

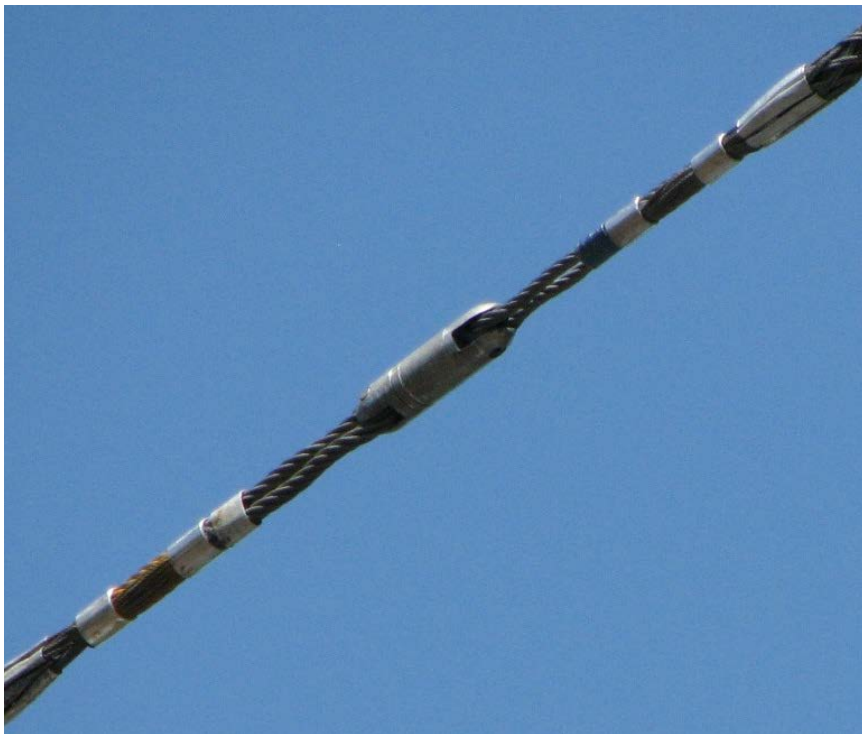

Figure 15: Swivel.

For sagging:

- **Pocketbook-style:** Pocketbook grips must be clean in the conductor grooves. The nuts used to close the grip must be free-running (easily turned full length by hand). Grips must be tested per the manufacturer requirements prior to use. The bolts must be snugged-up and then tightened with at least five passes applying full torque recommended by the manufacturer.



Figure 16: Pocketbook-style grips.

- **Klein “Chicago-style”:** Klein grips must be of catalog number 1628-XX and exactly sized to the conductor diameter to minimize strand distortion. Klein grips are the most commonly used grip and have an excellent track record.



Figure 17: Klein 1628-30 “Chicago-style” grip.

Other grips may be determined to be applicable for use with C⁷. Any grips should be qualified by the manufacturer for use with C⁷ and should be tested prior to use. Do not use grips that are not specifically authorized for C⁷. Some designs, and especially range-taking grips, will transmit excessive crushing force to the core and could cause damage.

For pulling tensions above 5000 lb (22 kN), a tandem gripping arrangement is needed to avoid excessive force on one grip. Figure 18 illustrates the tandem-gripping arrangement, which may be used with both pocketbook and Klein style grips.

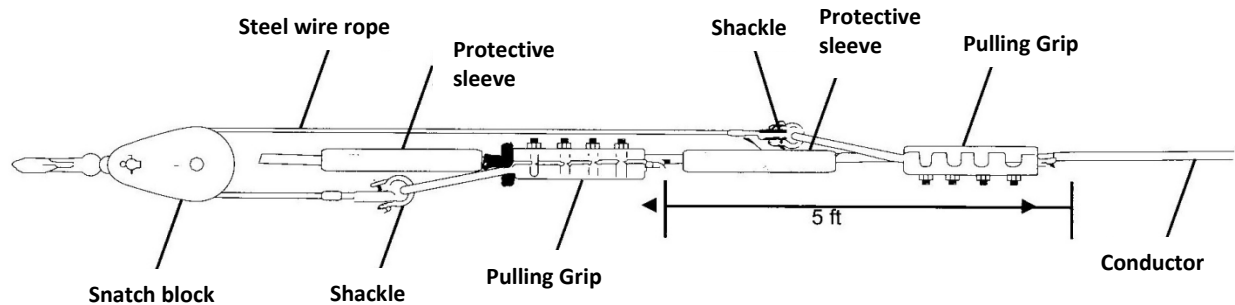

Figure 18: Tandem pocketbook-style grip configuration (also applicable to Klein grips).

Splice, Dead End, and Tap Connectors

As of publication of this guide, AFL[®] two-piece compression and PLP[®] formed-wire hardware are qualified for C⁷ conductor. Approval for each is on a case-by-case basis and depends on the conductor size and construction.

Fittings for C⁷ are similar to hardware for ACSS, but the size is larger to handle high tension and high operating temperatures. For formed wire fittings, ACSR and ACSS hardware may fit, but only hardware marked for C⁷ conductor will perform up to the full conductor capacity. For two-piece compression fittings, only hardware approved and marked for C⁷ should be used. Bolted T-taps and wedge-type clamps are suitable pending hardware manufacturer approval.

Bolted deadends (strain clamps), implosion connectors, and automatic splices are not qualified for use on C⁷. H-frame and parallel-groove (PG) tap connectors are not recommended. Implosive splices have not been tested on C⁷ as of this publication. Check with Southwire or your hardware manufacturer for a recommendation on usage of alternative fittings on C⁷ conductors.

Two-Piece Compression Hardware (available from AFL®)

AFL has qualified their two-piece compression fittings on both ACCS and ZTACCR versions of C⁷ conductor. C⁷ compression fittings install exactly like compression fittings for ACSR and ACCS, except that an aluminum buffer tube is slid over the core prior to crimping on the core grip. The fitting manufacturer has installation guides on their web site, and it is critical to follow their instructions to ensure long and reliable service life.

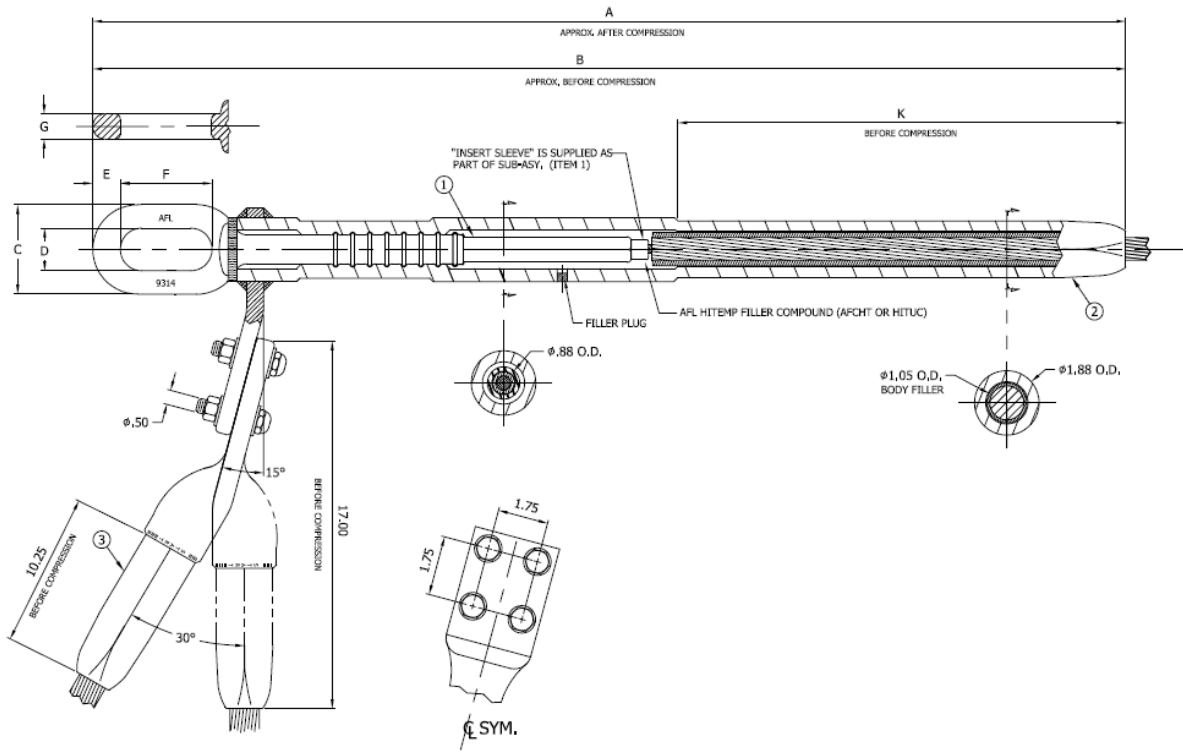

Figure 19: AFL Compression Dead End Assembly

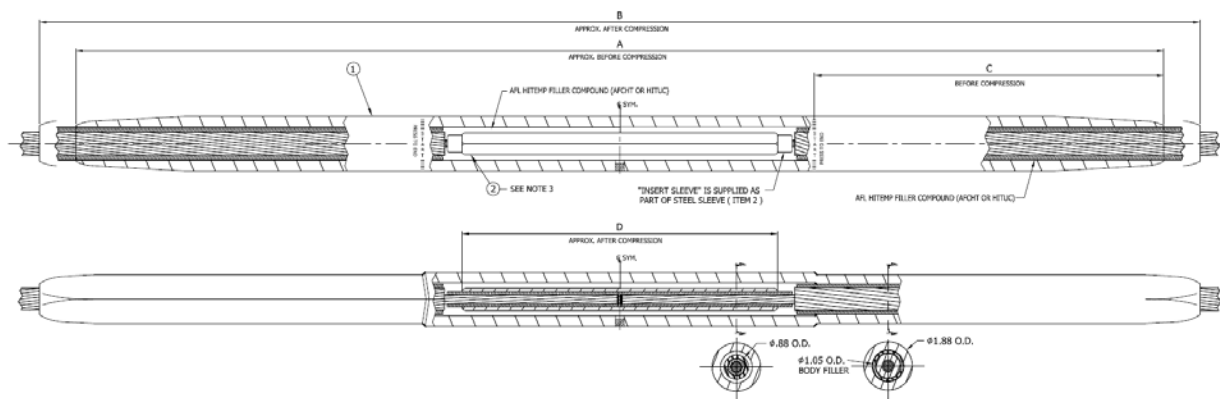

Figure 20: AFL Compression Splice Assembly

Formed Wire Hardware (available from PLP®)

PLP has qualified their Thermolign® formed-wire fittings on ZTACCR versions of C⁷ conductor. Formed-wire fittings are slightly more labor-intensive, but offer the advantage of tool-free installation. Again, the fitting manufacturer has installation guides on their web site, and it is critical to follow their instructions to ensure long and reliable service life.

THERMOLIGN® Dead-end Assembly Catalog Number - TLDE-0111

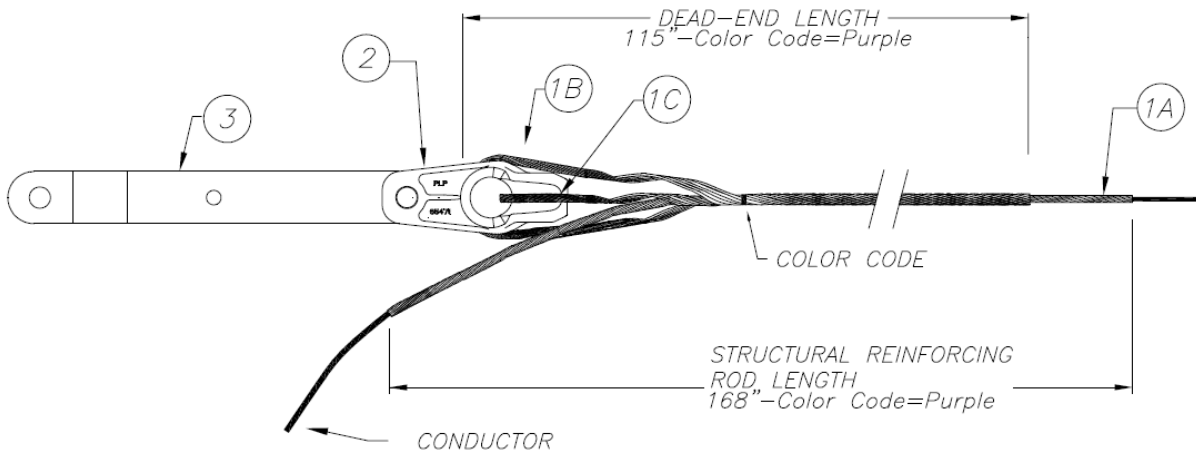

Figure 2120: PLP Thermolign Dead End Assembly



Figure 22: PLP Thermolign Splice Assembly

Suspension Units

A cushioned suspension system is required for C⁷ conductor. A bolted metal clamp has not been qualified and is therefore not acceptable. Rubber-lined clamping systems avoid crushing forces should clamp bolts be over-tightened. Rubber linings also help to prevent fatigue damage from Aeolian vibration. The suspension system must be rated to handle temperatures up to 225°C.

PLP and AFL have qualified their CGS® and HIBUS® suspension units on C⁷ conductor. Where operating conditions are extreme, there is an extra measure of protection offered by formed-

wire cushion-grip suspension units. Brand names are AGS® and GSA® for PLP and AFL, respectively.

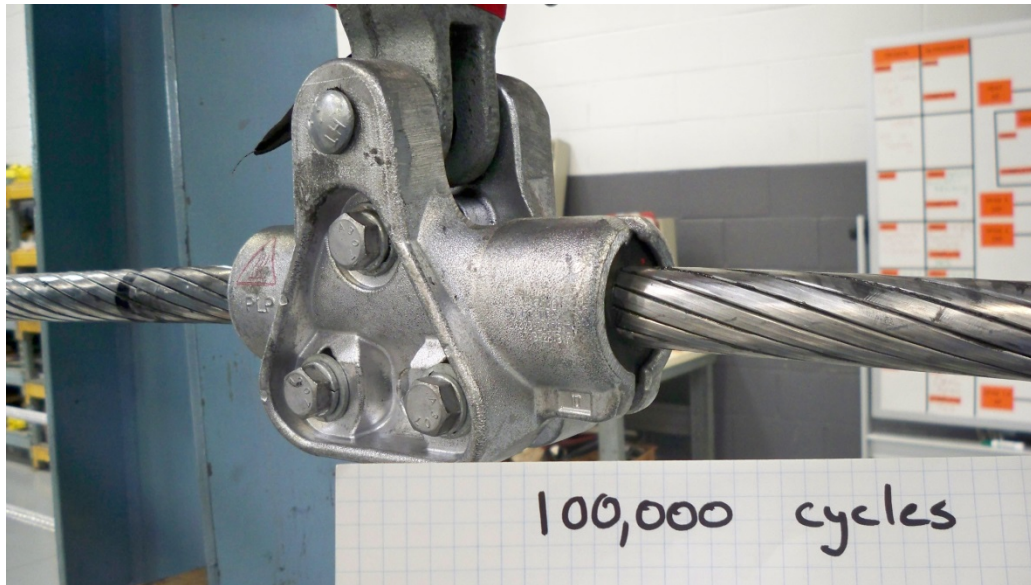

Figure 23: PLP cushion-grip suspension (CGS)

Spooling and Training

The minimum diameter for spooling and storing C⁷ conductor is 30 times the conductor diameter. A limit of 20 times the conductor diameter should be maintained at all times during temporary training and other handling requirements. Damage to the core will self-identify by deformation in the aluminum shell. If a permanent “set”, birdcage, or kink is seen, it should be evaluated for the possibility of damage to the composite core.

Conductor Oxidation

Exposure to air and moisture can cause oxidation to form on the conductor. Oxidation results from a chemical reaction between oxygen and aluminum, yielding an oxide layer on the conductor. While it is normal for oxidation to form, necessary steps should be taken to clean the conductor of oxidation at hardware application areas. The conductor must be brushed in these areas prior to installing hardware to ensure adequate metal-to-metal contact.

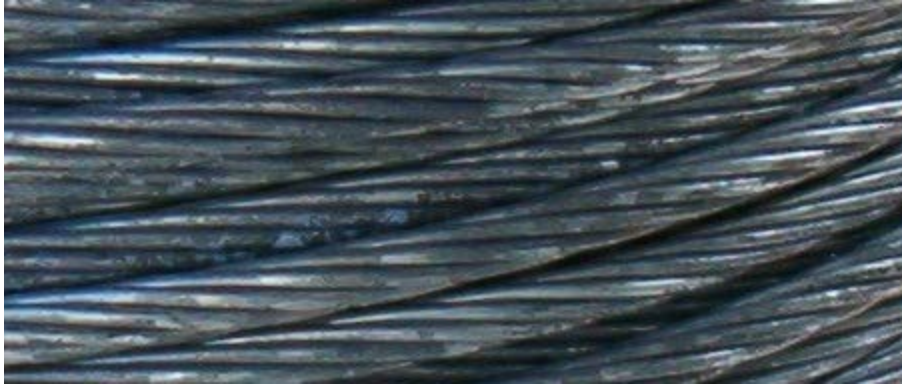

Figure 24: Oxidation on a conductor.

Conductor Staining

When conductor reels are stored outdoors, water can accumulate on the conductor on the underside of the reel. If the water contains chemicals from the surrounding atmosphere, a black stain known as a “water stain” can appear on the conductor. This has been found to be more prevalent in non-specular conductor because the drawing oils have been removed. Figure 25 shows an example of water staining.



Figure 25: Water stain on conductor.

Water stains are a cosmetic issue; they have no adverse effect on the performance or service life of the conductor. No corrosion in excess of normal oxidation results from the water stain. In most environments, the conductor will darken in the first few months after the line is energized, and the stain will no longer be noticeable. Aluminum Association Technical Bulletin TR3, “Guidelines for Minimizing Water Staining of Aluminum” discusses this issue in detail and contains advice for avoiding water staining.

Sagging Methods

Conductor sagging involves the use of stringing tables to determine the required sag or tension at a specific conductor temperature. Conductor temperature should be measured on the day of sagging using a conductor thermometer placed at or near the conductor. The conductor thermometer should be installed prior to sagging to allow for temperature stabilization. Conductor is often tensioned to the correct sag/tension using one of the following three methods: the stopwatch method, transit method, or dynamometer method.

Stopwatch Method

The stopwatch method involves pricking the conductor and measuring the time it takes the vibration wave to be reflected back a certain number of times. Three or five return waves usually provide an accurate measurement of sag. The governing equation for the stopwatch method can be seen below.

$$D = 122.7 \left(\frac{t}{2n} \right)^2$$

D = conductor sag, cm

t = time, sec.

n = number of return waves

Transit Method

The transit method includes three types of sagging methods: calculated angle of sight, calculated target, and horizontal line of sight. Choice of the best transit sagging method to use is determined by the terrain of the span in the right-of-way and span length. Tall structures on flat terrain and short spans indicate the calculated target or horizontal line of sight method would be most applicable. Steep slopes, long spans, and large sags indicate the calculated angle of sight method would be best.

Dynamometer Method

In the dynamometer method, a dynamometer is inserted in-line with the sagging equipment to get a direct measurement of line tension in the line. There should be minimal sheaves between the dynamometer and span being measured. This method works best on smaller conductors, shorter spans, and ruling spans containing one or two spans.

Vibration Dampers

C⁷, due to its light weight, is more prone to vibration issues than steel core conductors under the same tension. Therefore, in most applications, dampers are necessary to protect the conductor from fatigue damage from Aeolian vibration. Recommendations on type and placement of dampers on C⁷ lines should be made by the damper manufacturer. The mechanical impedance characteristics of C⁷ are different from conventional conductors. Dampers qualified for service on C⁷ are the only ones suitable. To date, only AFL and PLP have qualified dampers for C⁷ overhead conductor.

Many dampers utilize armor rods to provide added protection for C⁷. Dampers with rubber-lined clamps are also acceptable. Check with your damper manufacturer for their recommendations on use of armor rods with dampers.

Damper Spacing: always locate Stockbridge dampers per the manufacturer's recommendation. Placement of spacer/dampers in the span is not critical, and, for example, a damper may be relocated several meters to avoid a splice, marker sphere, or other obstruction. It is important to avoid symmetric spacing, as the dampers can cause unwanted movements in the span.

C⁷ Conductor Repair

If the conductor damage includes evidence of over-bending, kinking, or crushing, the suspect section should be cut out and a full-tension splice installed. If available, a portable x-ray unit can confirm the integrity of the core. If the core is confirmed to be intact, or if the damage is limited to outer abrasion or outer broken aluminum strands, conductor repair kits are available from both PLP and AFL. The PLP system is similar to their wrap-rod splice, and provides a 100% repair as long as the core is intact. PLP's conductor repair manual can be found at:

http://www.preformed.com/images/pdfs/Energy/Transmission/EN-TM-1000-5_TransmissionManual.pdf

C⁷ Conductor Maintenance and Operation

C⁷ conductor should be maintained and operated in a prudent manner to ensure the full service life is preserved. Company practices for line inspection and maintenance vary according to the service environment. Some items to consider for any overhead conductor:

- Regular fly-by or drive-by patrols to look for lightning damage, broken strands, broken or drooping vibration dampers, ROW encroachments and other issues that need follow-up repair or attention. Monthly is a common interval for cursory inspections.
- Review of system operation and system protection to avoid long-term overloads. C⁷ polymer composite core uses materials selected for best tolerance of high temperature, but should not operate above 180 °C continuously or above 200 °C for longer than 2000 hours during the life of the line. Conductor temperature should never exceed 225 °C.
- Climbing inspections are sometimes needed to check the condition of the hardware and other small parts that are subject to wear. Drone technology and high-resolution imagery are becoming competitive with climbing inspection for detecting issues that are not visible during fly-by or drive-by inspections.

Hardware Manufacturer Links

For more information on conductor hardware, including splices, dead-ends, grips, armor rod, repair sleeves, dampers, and suspension shoes, please see the hardware manufacturer websites below.

AFL: <http://www.aflglobal.com/Home.aspx>

PLP: <http://www.preformed.com/>

References

IEEE Standard 524-2014, "Guide to the Installation of Overhead Transmission Line Conductors."

Thrash, Ridley, Kim Nuckles, Amy Murrah, and Mark Lancaster. *Overhead Conductor Manual 2nd Edition*. N.p.: Southwire, 2007. Print.