

LIQUID CYLINDER



OPERATING MANUAL

- Cryo-Cyl 80HP
- Cryo-Cyl 120, 180, 230LP
- Dura-Cyl MCR 180MP/HP
- Dura-Cyl MCR 230LMP/HP
- Dura-Cyl MCR 160MP/HP
- Dura-Cyl MCR 200MP/HP
- Dura-Cyl MCR 265MP/HP
- Dura-Cyl 160MP/HP
- Dura-Cyl 180MP/HP
- Dura-Cyl 200MP/HP
- Dura-Cyl 230MP/HP
- Dura-Cyl 265MP/HP



Innovation. Experience. Performance.®

This edition of the Chart Liquid Cylinder Users Manual documents Release I and all subsequent releases of the Chart Inc. Dura-Series cryogenic liquid cylinders users manual. This edition has information regarding both Chart Dura-Cyl and Cryo-Cyl cryogenic liquid cylinders. Unless otherwise noted, the term Dura-Cyl/Cryo-Cyl Series refers to the Dura-Cyl 160MP, Dura-Cyl 160HP, Dura-Cyl 180MP, Dura-Cyl 180HP, Dura-Cyl 200MP, Dura-Cyl 200HP, Dura-Cyl 230MP, Dura-Cyl 230HP, Dura-Cyl 265MP, Dura-Cyl 265 HP, Cryo-Cyl 80 HP, Cryo-Cyl 120 LP, Cryo-Cyl 180LP, Cryo-Cyl 230LP, Dura-Cyl MCR 160MP, Dura-Cyl MCR 160 HP, Dura-Cyl MCR 180MP, Dura-Cyl MCR 180HP, Dura-Cyl MCR 200MP, Dura-Cyl MCR 200HP, Dura-Cyl MCR 230MP, Dura-Cyl MCR 230HP, Dura-Cyl MCR 265 MP and Dura-Cyl MCR 265 HP model cryogenic liquid cylinders.

This manual is intended to provide the user with the information necessary to operate and maintain the Dura-Cyl/Cryo-Cyl Series liquid cylinders. It is important that users of the above mentioned cryogenic liquid cylinders read fully and understand the information contained in this manual.

The manual is divided into the following sections to make it easier to look up information concerning a particular model of the Dura-Cyl/Cryo-Cyl Series.

Section 3 and 4 discuss the safety requirements needed to operate any of the Dura-Cyl/Cryo-Cyl Series. Additional safety information on cryogenics or the gases carried can be obtained from the Compressed Gas Association.

Section 5 explains how to determine the type or model of the various cryogenic liquid cylinders.

Section 6 lists the performance features and technical specifications of all the Dura-Cyl/Cryo-Cyl Series liquid cylinders. This should help in determining the model of cryogenic liquid cylinder needed for a specific application.

Section 7 talks about the general theories of operation of the Dura-Cyl/Cryo-Cyl Series models.

Section 8 thru 15 deals with the actual operation of the various Dura-Cyl/Cryo-Cyl Series models. These sections can be used as quick reference guides and will provide the specified information needed to operate each model.

Sections 16 and 17 are set up to aid with the routine maintenance and adjustments needed to operate the Dura-Cyl/Cryo-Cyl Series liquid cylinder.

Section 18 shows how to use the Dura-Cyl/Cryo-Cyl Series in specific applications. Various accessories are discussed as they aid the different applications.

Any comments or suggestions related to this manual are encouraged and should be forwarded in writing to:

Chart Inc.
 Technical Service Department
 407 Seventh Street NW
 New Prague, Minnesota 56071

2

TABLE OF CONTENTS

1 Preface	2	11 Operation of Dura-Cyl MCR-HP	37 - 42
2 Contents	3	General	
3 Safety	4 - 5	Filling	
4 Safe Handling	5 - 7	Parts Identification	
5 Introduction	8 - 11	Operation Pressure	
General		Liquid CO ₂ Withdrawal	
Cylinder Design		Gas withdrawal	
Cylinder Identification		Service and Maintenance	
Distributor Filling Responsibilities		12 Operation of Dura-Cyl HP	43 - 48
6 Features	12 - 16	General	
General		Filling	
Performance		Parts Identification	
Specifications		Operation Pressure	
7 Theory of Operation	17 - 20	Liquid CO ₂ Withdrawal	
General		Gas withdrawal	
Filling		Service and Maintenance	
Liquid Withdrawal		13 Operation of Cryo-Cyl 80 HP	49 - 52
Gas Withdrawal		General	
Economizer System		Filling	
8 Operation of Cryo-Cyl LP	21 - 24	Parts Identification	
General		Gas Withdrawal	
Filling		Service and Maintenance	
Parts Identification		14 Cryo-Cyl/Dura-Cyl Base Design	53 - 54
Operating Pressure		Footring Design	
Liquid Withdrawal		Caster Base Design	
Service and Maintenance		Base Identification Table	
9 Operation of Dura-Cyl MCR- MP	25 - 30	Parts Identification	
General		15 Troubleshooting	55 - 57
Filling		Loss of Vacuum	
Parts Identification		Pressure Too High	
Operating Pressure		Pressure Too Low	
Gas Withdrawal		16 Service and Maintenance	58 - 65
Service and Maintenance		General	
10 Operation of Dura-Cyl MP	31 - 36	O ₂ Cleaning	
General		Adjustments	
Parts Identification		MCR Regulator	
Operating Pressure		LCCM Regulator	
Gas Withdrawal		Level Gauge	
Service and Maintenance		Changing Services	
		17 Applications and Accessories	65 - 66
		18 Safety Bulletin	67 - 68

Chart has conducted a rigid test program for liquid cylinders, both internally and through an independent testing laboratory, to verify the safety of Chart equipment. Chart cylinders are safely designed with the following features:

- (1) An exclusive all stainless steel support system designed to withstand many years of rugged service.
- (2) A stainless steel neck tube that is designed not to break in case of a minor accident, such as a liquid cylinder being inadvertently tipped over.
- (3) A vacuum maintenance system specifically designed to provide long life and safety provisions.
- (4) Safety relief devices to protect the pressure vessel and vacuum casing, sized and selected in accordance with CGA Pamphlet S-1.1 "Safety Relief Devices for Cylinders." The safety of the inner pressure vessel is controlled by a pressure relief valve and rupture disc. The vacuum space is protected from overpressurization by the pump-out, based on the requirement of CGA 5-1.1-2003. The pump-out also functions as the vacuum port.

While Chart equipment is designed and built to rigid standards, no piece of mechanical equipment can ever be made 100% safe. Strict compliance with proper safety and handling practices are necessary when using a liquid cylinder or other compressed gas equipment. We recommend that all our customers re-emphasize safety and safe handling practices to all their employees and customers. While safety features have been designed into the unit and safe operations are anticipated, it is essential that the user of these liquid cylinders carefully read to fully understand all **WARNINGS**, *CAUTION* and Notes listed in this safety section and enumerated below. Also read to fully understand the information provided in the Safety Bulletins for Oxygen and Inert Gases located in Section 19 of this Manual. Periodic review of the Safety Summary is recommended.

WARNING

Excess accumulation of oxygen creates an oxygen enriched atmosphere (defined by the Compressed Gas Association as an oxygen concentration above 23 percent). In an oxygen enriched atmosphere, flammable items burn vigorously and could explode. Certain items considered non-combustible in air may burn rapidly in such an environment.

Keep all organic materials and other flammable substances away from possible contact with oxygen; particularly oil, grease, kerosene, cloth, wood, paint, tar, coal dust, and dirt which may contain oil or grease. DO NOT permit smoking or open flames in any area where oxygen is stored, handled, or used. Failure to comply with this warning may result in serious personal injury.

WARNING

Nitrogen and argon vapors in air may dilute the concentration of oxygen necessary to support or sustain life. Exposure to such an oxygen deficient atmosphere can lead to unconsciousness and serious injury, including death.

WARNING

The Dura-Cyl/Cryo-Cyl Series, with its stainless steel support system is designed, manufactured, and tested to function normally for many years of service. Chart does not suggest or warrant that it is ever safe to drop a liquid cylinder or let it fall over in oxygen or any other cryogenic service. In the event a liquid cylinder is inadvertently dropped, tipped over, or abused, slowly raise it to its normal vertical position. Immediately open the vent valve to release any excess pressure in a safe manner. As soon as possible, remove the liquid product from the vessel in a safe manner. If the vessel has been used in oxygen service, purge it with an inert gas (nitrogen). If damage is evident or suspected, return to Chart prominently marked "LIQUID CYLINDER DROPPED, INSPECT FOR DAMAGE".

WARNING

Before removing cylinder parts or loosening fittings, completely empty the liquid cylinder of liquid and release the entire vapor pressure in a safe manner. External valves and fittings can become extremely cold and may cause painful burns to personnel unless properly protected. Personnel must wear protective gloves and eye protection whenever removing parts or loosening fittings. Failure to do so may result in personal injury because of the extreme cold and pressure in the cylinder.

4 SAFE HANDLING

Caution

Only use replacement equipment which is compatible with liquid oxygen and has been cleaned for oxygen use. Do not use regulators, fittings, hoses, etc., which have been previously used in compressed air service. Similarly, do not use oxygen equipment for compressed air. Failure to comply with these instructions may result in serious damage to the liquid cylinder.

Caution

Dura-Cyl/Cryo-Cyl Series cryogenic liquid cylinders should be moved using an appropriate liquid cylinder cart or dolly. Do not roll liquid cylinders by handling rings. Dura-Cyl/Cryo-Cyl Series liquid cylinders must be used and stored in a vertical position except for normal cart or dolly movement. Do not lay, store, or ship a liquid cylinder on its side. When necessary to transport a liquid cylinder by truck, use a power lift gate, crane, or inclined ramp to lower the liquid cylinder. If the truck bed and dolly are not at the same height, do not attempt to manually lift or slide a liquid cylinder on or off a truck bed. Failure to comply with these procedures may result in damage to the liquid cylinder.

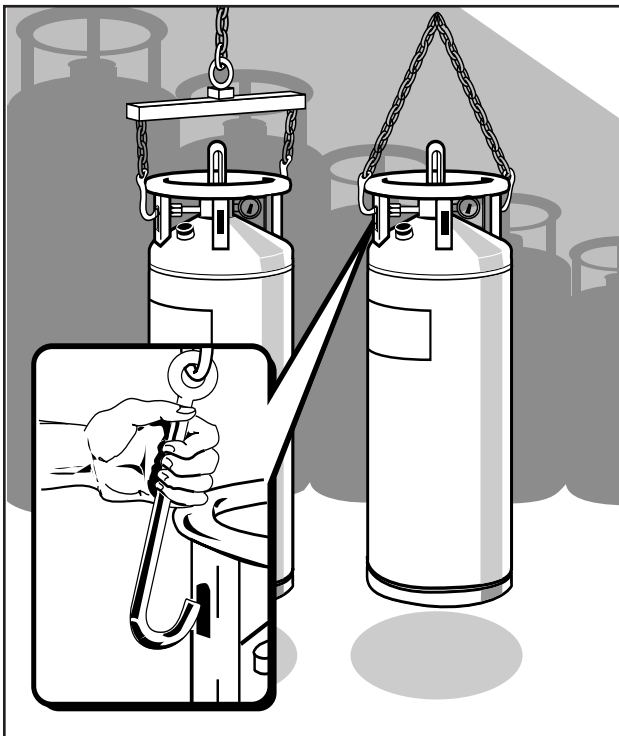

Figure A

This section describes and illustrates proper cylinder handling procedures. Major considerations for liquid cylinder handling are summarized as follows:

- Dura-Cyl/Cryo-Cyl Series should be moved only by utilizing an appropriate cylinder cart, roller base, or overhead hoist. See section 17 for approved equipment.
- Do not roll a liquid cylinder by the handling ring.
- Dura-Cyl/Cryo-Cyl Series cylinders should always be stored and operated in a vertical position.
- Never lay, store, or ship a cylinder on its side.
- When loading (or unloading) a cylinder onto a truck, use a power lift gate, crane, or an inclined ramp. Never attempt to manually lift or slide a liquid cylinder on or off of a truck bed.

Dura-Cyl/Cryo-Cyl Series liquid cylinder can be safely handled by using a cylinder cart, roller base, or an overhead hoist. When moving the unit, keep the unit upright at all times except for those instances when it is slightly tipped for loading or unloading.

Dura-Cyl/Cryo-Cyl Series liquid cylinders are durable liquid cylinders designed to withstand common handling; however, abusing a unit may damage the liquid cylinder to the extent that it must be returned to the factory for repair.

Preferred Lifting Procedure

The Dura-Cyl/Cryo-Cyl Series liquid cylinders are provided with a ring on the top of the liquid cylinder. The ring is designed to protect the plumbing components and should not be used to handle or lift the liquid cylinders. The ring is attached to the cylinder with two or four posts. Each post has a lifting hole in it that can be used to lift or attach a handling cart.

To lift a Dura-Cyl/Cryo-Cyl Series liquid cylinder, attach the properly sized hooks and chains into both of the holes and lift vertically. Figure A shows how a chain system can be used to lift the liquid cylinder. The spreading bar is the preferred method, but the double chain system is acceptable.

Preferred Handling Procedures

Figure B illustrates the preferred cylinder handling procedures. It shows the proper way to approach a cylinder when using a pneumatic-tired hand truck. It shows how to engage the pickup hook in the post slot and illustrates it properly engaged. It then illustrates how to tilt the cylinder back once the pickup hook and post slot are engaged. The approximate tilt position of the cart should be maintained when transporting a cylinder.

Alternate Procedures

The use of a four wheel roller base that has been designed expressly for transporting a liquid cylinder is acceptable. See Section 17 for approved equipment.

This method is used when frequent and short distance moves of a liquid cylinder are required. Before utilizing this method of transportation, make sure the area over which the liquid cylinder is to be moved is flat and smooth.

The hard rubber-tired hand truck (or a hand truck having swivel rear wheels) can be used in place of a pneumatic-tired hand truck. As with the roller base, use of these methods should be limited to facilities having relatively smooth floors.

A semi-permanent handling carriage can be used which locks the Dura-Cyl/Cryo-Cyl Series liquid cylinder to the base for transporting cylinders. This arrangement is ideal for those users having the capability of filling their own liquid cylinders.

Refer to Section 17 of this manual for ordering information on these handling accessories.

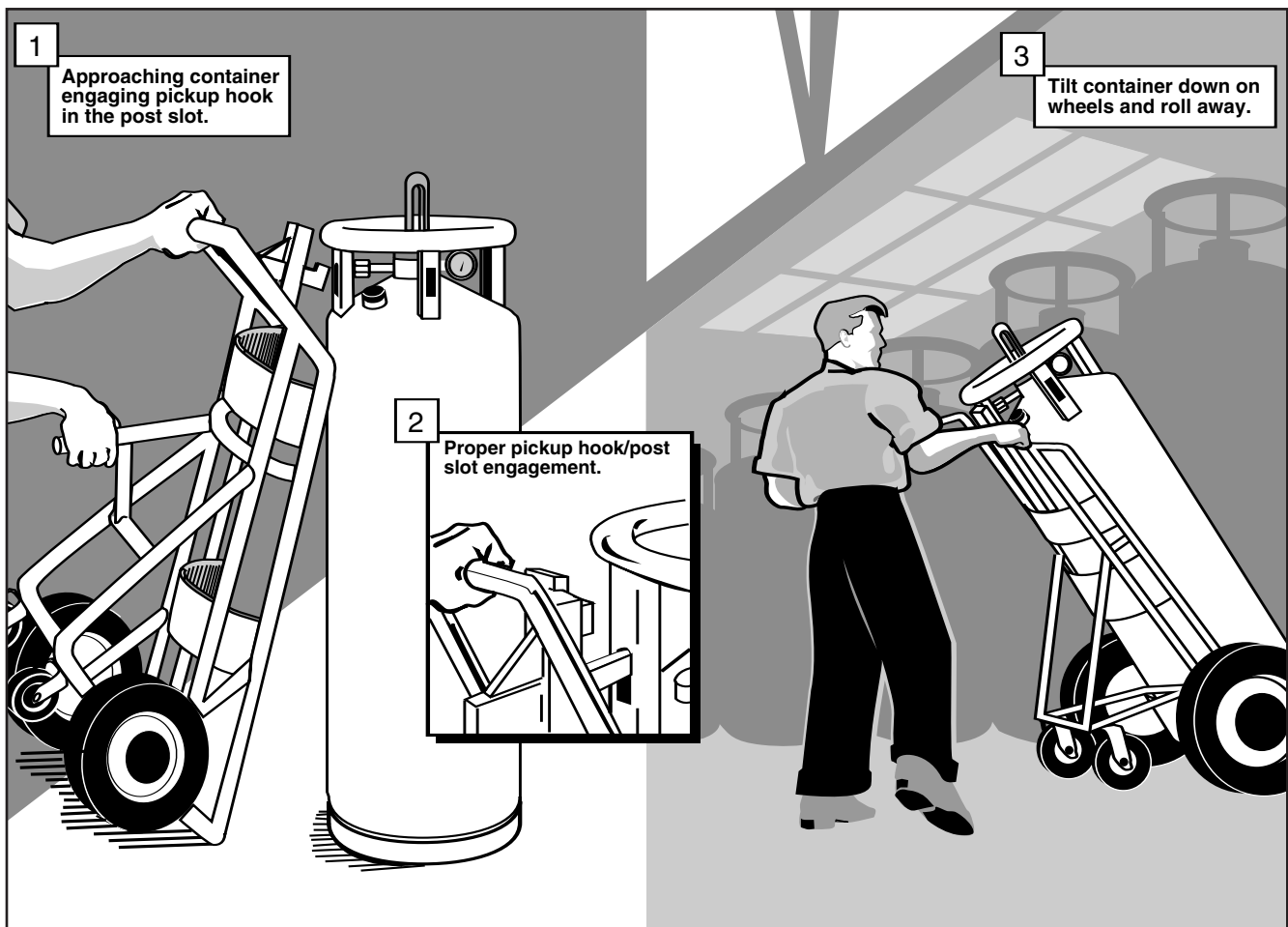

Figure B

4 SAFE HANDLING

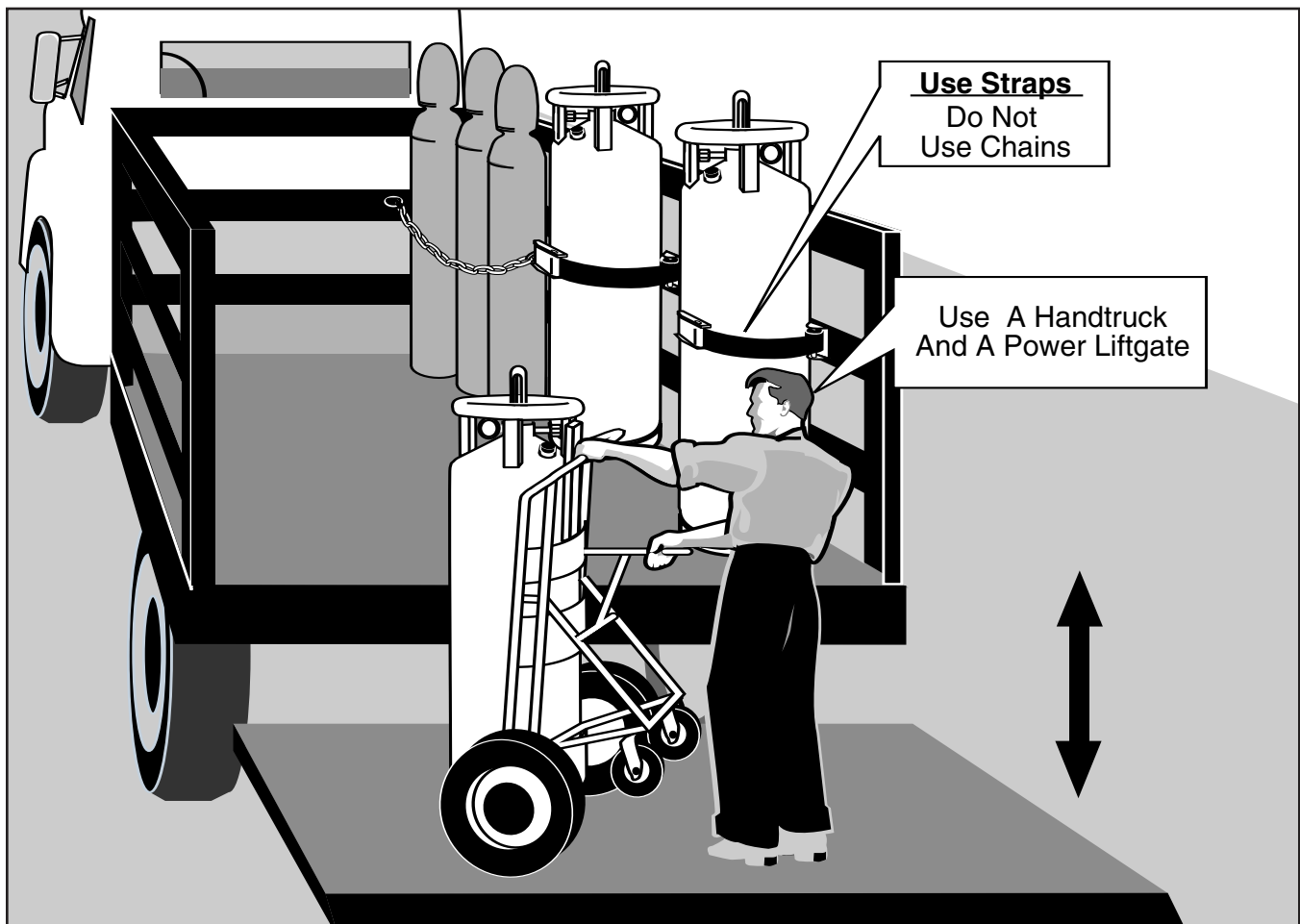

Figure C

Transporting Procedures

The Dura-Cyl/Cryo-Cyl Series liquid cylinders are designed to withstand the normal handling associated with transportation by truck.

Figure C illustrates how a cylinder should be secured in a truck for transportation. A nylon or other suitable strap should be used. The use of a strap prevents scratching on the surface and provides a reliable tie down arrangement. Never use a chain type binder.

Do Not use chains. Chain tie downs will scratch the finish and could crush or dent the vacuum jacket.

Figures C also shows the proper method of unloading a cylinder from a truck. Note that the pneumatic-tired hand truck should be used and that the cart and liquid cylinder are lowered to the ground by use of a power lift gate.

General

The Chart Inc. Dura-Series cryogenic liquid cylinders and the Cryo-Cyl Series cryogenic liquid cylinders (figure D) are double walled, vacuum and multi-layer insulated cylinders designed for the transportation and storage of liquefied gases. These liquid cylinders are designed for the transportation and storage of cryogenic products which can be used as either gas or liquid. All of the Dura-Cyl or Cryo-Cyl Series liquid cylinders can be used for liquid argon, liquid nitrogen, and liquid oxygen. The Dura-Cyl HP or Cryo-Cyl HP can also be used for transporting liquid carbon dioxide (CO₂) or liquid nitrous oxide (N₂O).

The Cryo-Cyl Series liquid cylinders have model distinctions for low pressure liquid withdrawal (LP). For Dura-Cyl series of liquid cylinders model distinctions for medium pressure liquid and gas withdrawal (MP), high pressure liquid and gas withdrawal (HP) and the very high pressure liquid and gas withdrawal (VHP). See section 6, Specifications, for more detail.

The Dura-Cyl/Cryo-Cyl series liquid cylinders also have capacity distinctions; the number after their name that designates net capacity in liters (the Dura-Cyl 180 indicates 180 liters capacity). See section 6, Specifications, for more detail.

The Dura-Cyl series of liquid cylinders have two styles of pressure regulation, the LCCM pressure manifold on the Dura-Cyl and the combination pressure regulator on the Dura-Cyl MCR.

The portable liquid cylinders provide a reliable, convenient, and economical method for the transportation and delivery of liquefied gas products. They are primarily used as a self-contained gas supply. They can be used with a variety of accessories such as the M-45 Manifold to provide larger gas storage capacities. Refer to Section 17 for details on applications.

Cylinder Design

The Dura-Cyl/Cryo-Cyl Series liquid cylinders are designed, manufactured, and tested to the requirements of the U.S. DOT and Transport Canada 4L specification. They are specifically authorized by the U.S. Department of Transportation for the transporting of liquid nitrogen, oxygen, argon, carbon dioxide, and nitrous oxide. They are specifically authorized by

Transport Canada for the transporting of liquid nitrogen, oxygen, and argon. They are authorized by Transport Canada for the transporting of carbon dioxide and nitrous oxide with an exemption.

The inner pressure vessel is constructed of stainless steel and supported within an outer stainless steel vacuum jacket. The support system is an all stainless steel internal support, designed for low heat leak and high strength.

The illustration in Figure E shows the major components of the Dura-Cyl/Cryo-Cyl Series liquid cylinders. The space between the inner and outer vessel makes up the insulation system. Multiple-layer insulation and high vacuum assures long holding time. The insulation system is designed for long term vacuum retention and is permanently sealed at the factory. The vacuum space is protected from overpressurization by the pump-out, based on the requirement of CGA 5-1.1-2003. The pump-out also functions as the vacuum port.

The outer vacuum jacket of the liquid cylinder contains an internal vaporizer which converts the cold liquid to gas. Refer to Section 6, figure I and J, for the gas withdrawal curves. The internal pressure building system allows for immediate use of the cylinder by automatically building pressure to the preset operating pressure and maintaining it there during gas withdrawal. Refer to Section 6, figure H, for the pressure builder's performance curves.

Each liquid cylinder is equipped with a stainless steel ring to protect the plumbing components. The ring on the Cryo-Cyl is connected to the cylinder with two handling posts; the Dura-Cyl uses four handling posts. The posts have slots for ease in handling with a hand truck or an overhead hoist. Hand trucks that can be supplied by Chart are described in Section 17.

The Dura-Cyl/Cryo-Cyl Series cryogenic liquid cylinders are constructed with all operating controls situated at the top of the cylinder for ease in gas withdrawal and liquid dispensing operations. In a stand-alone operating environment it enables the user, through use of the vent, liquid, pressure building, and pressure relief devices, to completely control the liquid cylinder's operation.

To protect the inner pressure vessel from over pressurization, the unit includes a safety pressure relief valve. The liquid cylinders are further protected from

5 INTRODUCTION



Figure D

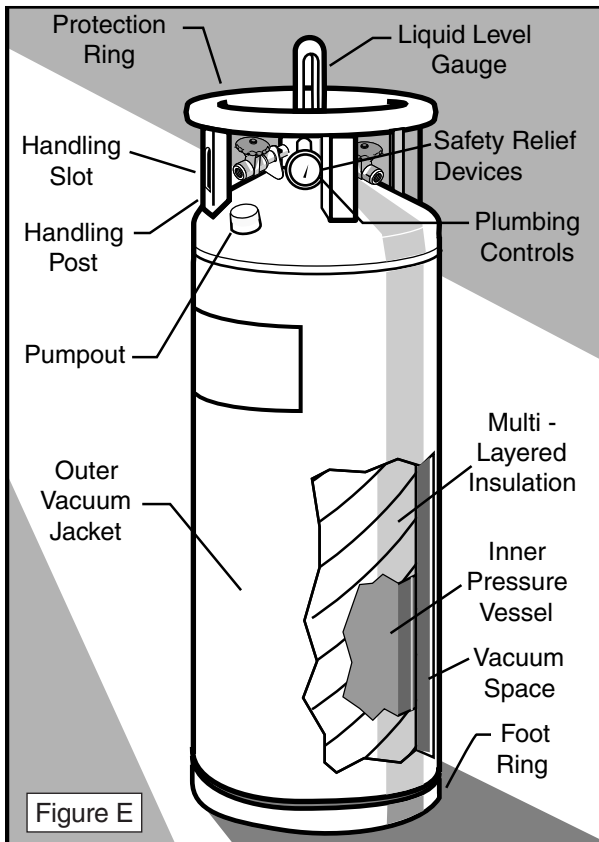

over pressurization by a bursting disc that acts as a secondary relief device. These devices meet the requirements of CGA Pamphlet S-1.1 “Pressure Relief Device Standard — Part 1 — Cylinders For Compressed Gases.”

A back control regulator is used to build and maintain operator pressure while assuring a no-loss operation under normal usage during gas withdrawal service. The no loss portion of the regulator (referred to as the economizer) allows gas withdrawal directly from the vapor space of the cylinder until liquid cylinder head pressure is reduced to the normal operating range. This important feature is useful whenever a liquid cylinder has been inactive for a period of several days or whenever normal heat leak may have created an increase in head pressure.

For precise regulation of the outlet gas, add a final line gas regulator at the gas use connection. The operating pressure can be increased to the pressure control valve setting (if necessary) by changing the regulator.

These Chart liquid cylinders provide a complete self-contained liquid or gas supply system for industrial, laboratory, or hospital use.

Cylinder Identification

There are twenty-four Dura-Cyl/Cryo-Cyl Series liquid cylinders described in this manual. They vary in size, capacity, pressure, gas service and various plumbing features. It is important that these liquid cylinders can be easily identified.

The following table shows each model by name and indicates its capacity and pressure rating. The sight

gauge protector color is an easy way to determine the pressure rating of a liquid cylinder.

The data plate (Figure G) is permanently attached to the handling post of the liquid cylinder. The data plate shows the serial number and pressure rating for that cylinder. Do not remove or alter the data plate in any way.

Model	Gross Storage Capacity (Liter)	Maximum Operating Pressure (PSIG)	Sight Gauge Protector Color
Cryo-Cyl 80 HP	85	350	orange
Cryo-Cyl 120 LP	120	22	yellow
Cryo-Cyl 180 LP	196	22	yellow
Cryo-Cyl 230 LP	240	22	yellow
Dura-Cyl 160 MP	176	230	blue
Dura-Cyl 160 HP	176	350	orange
Dura-Cyl 180 MP	196	230	blue
Dura-Cyl 180 HP	196	350	orange
Dura-Cyl 200 MP	209	230	blue
Dura-Cyl 200 HP	209	350	orange
Dura-Cyl 230 MP	240	230	blue
Dura-Cyl 230 HP	240	350	orange
Dura-Cyl 265 MP	276	230	blue
Dura-Cyl 265 HP	276	350	orange
Dura-Cyl MCR 160 MP	176	230	blue
Dura-Cyl MCR 160 HP	176	350	orange
Dura-Cyl MCR 180 MP	196	230	blue
Dura-Cyl MCR 180 HP	196	350	orange
Dura-Cyl MCR 200 MP	209	230	blue
Dura-Cyl MCR 200 HP	209	350	orange
Dura-Cyl MCR 230 MP	240	230	blue
Dura-Cyl MCR 230 HP	240	350	orange
Dura-Cyl MCR 265 MP	276	230	blue
Dura-Cyl MCR 265 HP	276	350	orange

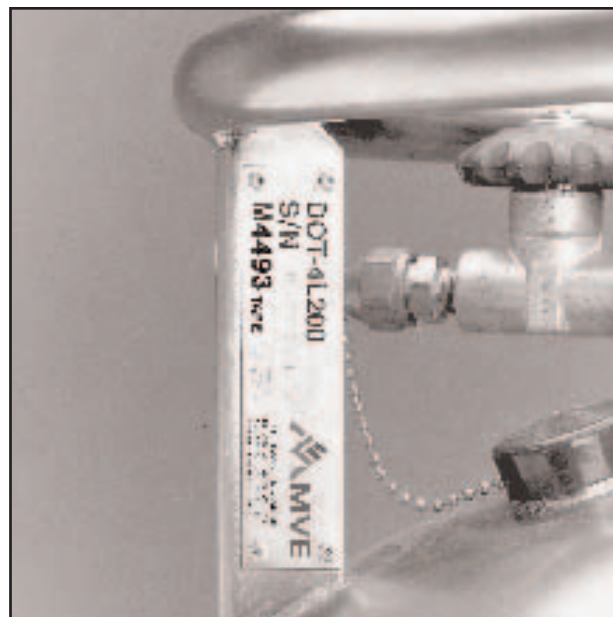

Figure G

5 INTRODUCTION

Responsibilities of Distributor and Fillers of Liquid Cylinders

Chart is stating below the responsibilities of the filler of any cryogenic liquid cylinder:

1. The cylinder must be in a safe condition.

The filler is responsible for confirming that any cylinder to be filled is in its proper working condition. This includes that:

- It has an acceptable vacuum.
- The relief system is in place and functioning.
- There is no structural damage to the cylinder.
- All warning labels are in place and legible.

2. Do not overfill the cylinder.

The cylinders are not to be filled beyond the recommended filling weight for the liquid being dispensed.

3. Dispense only to knowledgeable users.

The filler must determine that the user is knowledgeable about the general characteristics of the product and the proper safety precautions for its use. Do not allow customers to fill their own cylinders.

4. Dispose of cylinders properly.

To eliminate the risk of injury from the improper reuse of cryogenic (vacuum jacketed) cylinders, before disposal, destroy the cylinder's pressure retaining capability.

We recommend:

1. Purge the cylinder's contents.
2. Drill multiple holes through the cylinder and its vacuum casing or otherwise puncture the tank.

Do it yourself! Don't assume it will be done by the scrap dealer.

General

The Chart cryogenic liquid cylinders were designed to furnish a convenient, reliable, and economical method for the transportation and delivery of liquefied gases. Important features of these liquid cylinders include:

- * The Dura-Cyl/Cryo-Cyl Series liquid cylinders are constructed with an all stainless steel internal support system designed for low heat leak and high strength.
- * These cylinders are easily handled by one person.
- * Gas stored in liquid form in a Dura-Cyl/Cryo-Cyl Series liquid cylinder is more pure than gas stored in conventional cylinders.
- * During periods of non-use, pressure will rise in a cryogenic liquid cylinder. The highly efficient insulation system minimizes the rate of pressure rise. This allows for a reasonable period of non-use without any venting of product from the pressure relief valve.
- * Internal pressure building and vaporization systems permit a continuous flow of gas without need for an external vaporizer.
- * The pressure control regulator automatically maintains working pressure with minimum product loss.
- * Cylinders can be used singularly or can be manifolded to provide a continuous gas supply.

Performance

The performance of a liquid cylinder can be shown in its ability to hold a cryogenic liquid and dispense it as a gas.

The normal evaporation rate (NER) is an indication of how well the insulation system performs its ability to hold cryogenic liquid. The Dura-Cyl/Cryo-Cyl Series NER is shown on the specification chart on pages 14 thru 16. Figure L indicates how the insulation performance effects the holding time for CO₂ or N₂O.

The pressure building system can be measured by how fast it can increase pressure in the liquid cylinder (Figure H) and how well it maintains pressure while gas is being withdrawn from the cylinder (Figures I and K).

The performance of the vaporizer to convert cold liquid into gas is shown by how the outlet gas temperature drops as the gas flow rate increases.

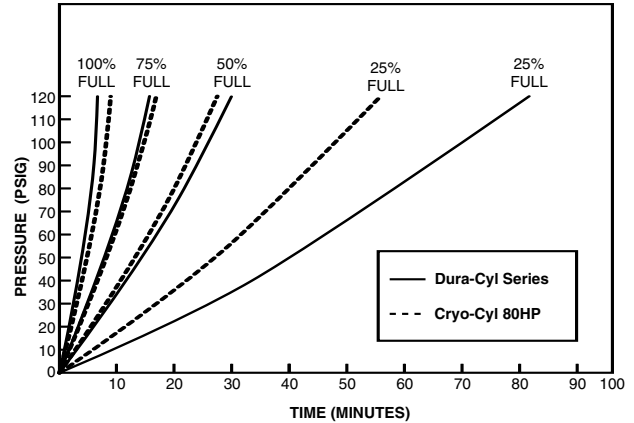
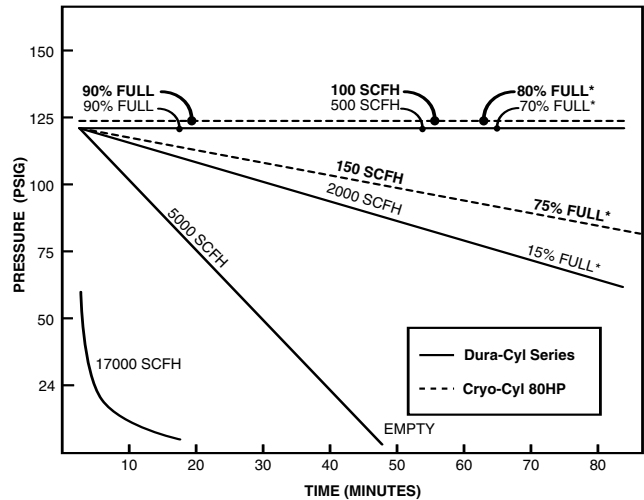

Figure H

Figure H illustrates the expected liquid cylinder pressure building rate (with liquid nitrogen) versus time.



* Amount of liquid left at conclusion of test

Figure I

Figure I illustrates how the pressure builder will maintain delivery pressure at various flow rates. (See note 1 and 2)

Notes:

1. Curves assume liquid withdrawal from tank and use of free standing vaporizer.
2. Pressure builder valve open and pressure control regulator at 125 psi.

6 FEATURES

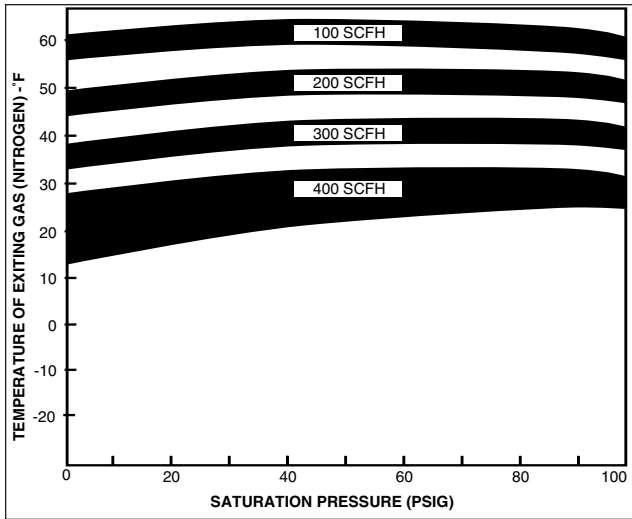

Figure J-1

Figure J-1 illustrates vaporizer performance for the Dura-Cyl series liquid cylinders.

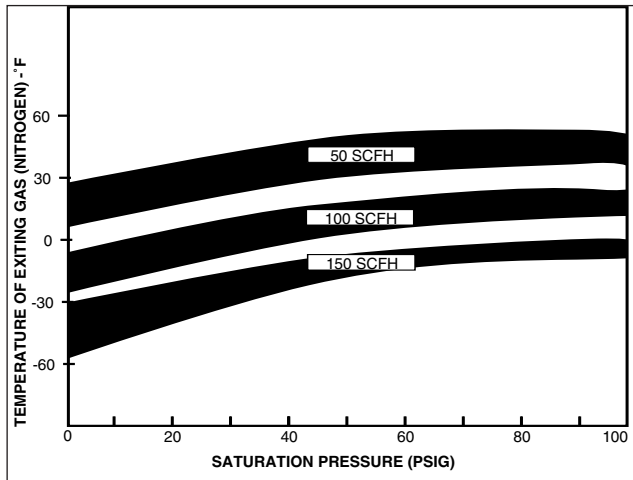

Figure J-2

Figure J-2 illustrates vaporizer performance for the Cryo-Cyl 80 HP.

Notes:

1. Non-controlled environment – 80° F, 50% Relative Humidity, light breeze at 120 psig outlet.
2. For controlled environment – 70°, 30 % Relative Humidity, still air, subtract 20 ° F.
3. For outlet gas pressure – ATM, subtract 5° F.
4. For outlet gas pressure – 80 psig, subtract 2° F.
5. For argon, add 10° F.
6. For oxygen, subtract 7° F.
7. Temperature obtained after one hour of continuous usage.

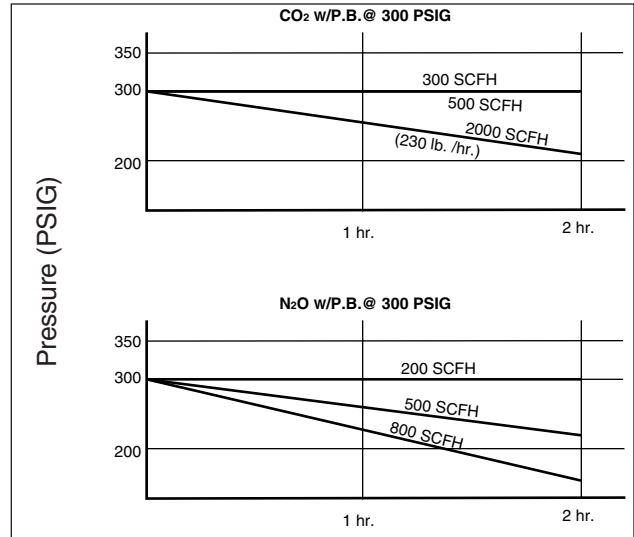

Figure K

Figure K illustrates continuous flow rates for CO₂ and N₂O when a pressure-build coil is used and adequate external vaporization is present (Dura-Cyl HP only).

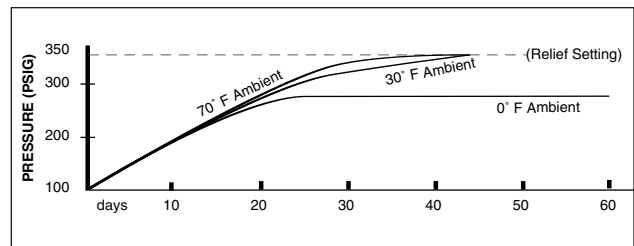

Figure L

Figure L illustrates Dura-Cyl HP holding times for CO₂ and N₂O.

Performance data provided on the illustrations represents typical values. Actual values may vary depending on ambient conditions and/or the condition of the liquids.

FEATURES 6

SPECIFICATIONS	CHART DURA-CYL & DURA CYL MCR				
	160 MP	160 HP	180 MP	180 HP	200 MP
Physical Characteristics					
Diameter - inches (cm.)	20 (50.8)	20 (50.8)	20 (50.8)	20 (50.8)	20 (50.8)
Height - inches (cm.) [†]	59.6 (151.3)	59.6 (151.3)	63.5 (161.3)	63.5 (161.3)	65.8 (167.1)
Empty Weight - lbs. (kg.)	250 (113.4)	280 (127.0)	260 (117.8)	300 (136.1)	280 (126.9)
Fill Weight ^{**}	See pg. 35	See pg. 47	See pg. 35	See pg. 47	See pg. 35
Design Specification (DOT/CTC)	4L	4L	4L	4L	4L
DOT Service Pressure psig (BAR)	200 (13.8)	292 (20.1)	200 (13.8)	292 (20.1)	200 (13.8)
Relief Valve Setting psig (BAR)	230 (15.9)	350 (24.1)	230 (15.9)	350 (24.1)	230 (15.9)
Normal Operating Pressure psig (BAR)	40-160 (2.8-11.0)	80-320 (5.5-22.0)	40-160 (2.8-11.0)	80-320 (5.5-22.0)	40-160 (2.8-11.0)
Normal Evaporation Rate					
• Nitrogen	2%	2%	1.9%	1.9%	1.85%
• Oxygen or Argon	1.4%	1.4%	1.3%	1.3%	1.2%
• CO ₂ or N ₂ O	-	0.5%	-	0.5%	-
Gross Capacity (liters)	(176)	(176)	(196)	(196)	(209)
Storage Capacity, Liquid (liters)	(165)	(165)	(185)	(185)	(196)
Storage Capacity, Gas Cu. Ft. (Nm ³)					
• Nitrogen	3685 (97)	3464 (91)	4099 (108)	3864 (102)	4375 (115)
• Oxygen	4577 (120)	4348 (114)	5096 (134)	4843 (127)	5435 (143)
• Argon	4448 (117)	4226 (111)	4961 (130)	4709 (124)	5290 (139)
• CO ₂	-	3382 (89)	-	3766 (99)	-
• Nitrous Oxide	-	3207 (84)	-	3574 (94)	-
Gas Delivery Rate scfh (Nm ³ /hr.)					
• Nitrogen, Oxygen, Argon	350 (10)	350 (10)	350 (10)	350 (10)	400 (11)
• CO ₂ or N ₂ O	-	110 (3)	-	110 (3)	-
Liquid Level Gauge	Dial Type	Dial Type	Dial Type	Dial Type	Dial Type
Construction Material	Stainless	Stainless	Stainless	Stainless	Stainless
LCCM Pressure Control Manifold Range					
psig	40-160	80-320	40-160	80-320	40-160
BAR	(2.8-11.0)	(5.5-22.0)	(2.8-11.0)	(5.5-22.0)	(2.8-11.0)
MCR Pressure Control Combo Reg. Range					
psig	50-175	150-350	50-175	150-350	150-350
BAR	(3.4-12.0)	(10.3-24.1)	(3.4-12.0)	(10.3-24.1)	(10.3-24.1)
Connections	See pg. 31	See pg. 43	See pg. 31	See pg. 43	See pg. 31
Finish	Stainless	Stainless	Stainless	Stainless	Stainless
Base Construction	Stainless Steel Footring	Stainless Steel Footring	Stainless Steel Footring	Stainless Steel Footring	Stainless Steel Footring

Notes:

- ^{**} At lower relief valve settings, weights and capacities are higher (See Fill Weight Table)
- Peaks of up to 4 X continuous flow rates can be sustained for 5 minutes if the vaporizer coils are allowed to thaw in between.
- [†] Height may vary on caster base models depending on specified wheel diameter.

6

FEATURES

SPECIFICATIONS	CHART DURA-CYL & DURA-CYL MCR				
	200HP	230MP	230HP	265MP	265HP
Physical Characteristics					
Diameter - inches. (cm.)	20 (50.8)	26 (66.0)	26 (66.0)	26 (66.0)	26 (66.0)
Height - inches (cm.) [†]	65.8 (167.1)	54.8 (139.2)	54.8 (139.2)	59.8 (151.9)	59.8 (151.9)
Empty Weight - lbs. (kg.)	320 (145.1)	324 (147)	375 (170)	353 (160)	430 (195)
Fill Weight ^{††}	See pg. 47	See pg. 35	See pg. 47	See pg. 35	See pg. 47
Design Specification (DOT/CTC)	4L	4L	4L	4L	4L
DOT Service Pressure psig (BAR)	292 (20.1)	200 (13.8)	292 (20.1)	200 (13.8)	292 (20.1)
Relief Valve Setting psig (BAR)	350 (24.1)	230 (15.9)	350 (24.1)	230 (15.9)	350 (24.1)
Normal Operating Pressure psig (BAR)	80-320 (5.5-22.0)	40-160 (2.8-11.0)	80-320 (5.5-22.0)	40-160 (2.8-11.0)	80-320 (5.5-22.0)
Normal Evaporation Rate					
• Nitrogen	1.85%	1.8%	1.8%	2.0%	2.0%
• Oxygen or Argon	1.2%	1.2%	1.2%	1.4%	1.4%
• CO ₂ or N ₂ O	0.5%	–	0.5%	–	0.5%
Gross Capacity (liters)	(209)	(240)	(240)	(276)	(276)
Storage Capacity, Liquid (liters)	(196)	(230)	(230)	(265)	(265)
Storage Capacity, Gas Cu. Ft. (Nm ³)					
• Nitrogen	4113 (108)	5024 (132)	4734 (124)	5769 (152)	5438 (143)
• Oxygen	5157 (136)	6244 (164)	5930 (156)	7186 (189)	6811 (179)
• Argon	5019 (132)	6073 (160)	5763 (151)	6982 (183)	6634 (174)
• CO ₂	4011 (105)	–	4614 (121)	–	5305 (139)
• Nitrous Oxide	3810 (100)	–	4378 (115)	–	5034 (132)
Gas Delivery Rate scfh (Nm ³ /hr.)					
• Nitrogen, Oxygen, Argon	400 (11)	400 (11)	400 (11)	400 (11)	400 (11)
• CO ₂ or N ₂ O	110 (3)	–	110 (3)	–	110 (3)
Liquid Level Gauge	Dial Type	Dial Type	Dial Type	Dial Type	Dial Type
Construction Material	Stainless	Stainless	Stainless	Stainless	Stainless
LCCM Pressure Control Manifold Range					
psig	80-320	40-160	80-320	40-160	80-320
BAR	(5.5-22.0)	(2.8-11.0)	(5.5-22.0)	(2.8-11.0)	(5.5-22.0)
MCR Pressure Control Combo Reg. Range					
psig	150-350	50-175	150-350	50-175	150-350
BAR	(10.3-24.1)	(3.4-12.0)	(10.3-24.1)	(3.4-12.0)	(10.3-24.1)
Connections	See pg. 43	See pg. 31	See pg. 43	See pg. 31	See pg. 43
Finish	Stainless	Stainless	Stainless	Stainless	Stainless
Base Construction	Stainless Steel Footring	Caster Base	Caster Base	Caster Base	Caster Base

Notes: The DURA-CYL MP series is not approved for use with CO₂ or N₂O.
[†] At lower relief valve settings, weights and capacities are higher (See Table)
Peaks of up to 4 X continuous flow rates can be sustained for 5 minutes if the vaporizer coils allowed to thaw in between.
^{††} Height may vary on caster base models depending on specified wheel diameter.
Dura-Cyl has square caster base & Dura-Cyl MCR has round caster base.

SPECIFICATIONS	CHART CRYO-CYL			
	80 HP	120 LP	180LP	230 LP
Physical Characteristics				
Diameter - inches. (cm.)	20 (50.8)	20 (50.8)	20 (50.8)	26 (66.0)
Height - inches (cm.) [†]	39.5 (100.3)	51 (129.5)	63.5 (161.3)	54.8 (139.2)
Empty Weight - lbs. (kg.)	165 (74.8)	165 (74.8)	210 (95.2)	290 (131.5)
Fill Weight	See pg. 52	See pg. 24	See pg. 24	See pg. 24
Design Specification (DOT/CTC)	4L	4L	4L	4L
DOT Service Pressure psig (BAR)	292 (20.1)	100 (6.9)	100 (6.9)	100 (6.9)
Relief Valve Setting psig (BAR)	350 (24.1)	22 (1.5)	22 (1.5)	22 (1.5)
Normal Operating Pressure psig (BAR)	75-175 (5.2-12.0)	10-100 (0.7-6.9)	10-100 (0.7-6.9)	10-100 (0.7-6.9)
Normal Evaporation Rate				
• Nitrogen	3.0%	2.0%	1.5%	1.5%
• Oxygen or Argon	2.0%	1.4%	1.0%	1.0%
• CO ₂ or N ₂ O	0.8%	-	-	-
Gross Capacity (liters)	(85)	(120)	(196)	(240)
Storage Capacity, Liquid (liters)	(80)	(110)	(185)	(230)
Storage Capacity, Gas cu. ft.(BAR)				
• Nitrogen	1670 (44)	-	-	-
• Oxygen	2089 (55)	-	-	-
• Argon	2040 (54)	-	-	-
• CO ₂	1634 (43)	-	-	-
• Nitrous Oxide	1546 (41)	-	-	-
Gas Delivery Rate scfh (Nm ³ /hr.)				
• Nitrogen, Oxygen, Argon	100 (3)	-		-
• CO ₂ or N ₂ O	30 (1)	-		-
Liquid Level Gauge	Dial Type	Float	Float	Float
Construction Material	Stainless	Stainless	Stainless	Stainless
Pressure Building Regulator				
psig	75-175	0-25	0-25	0-25
(BAR)	(5.2-12.0)	(0-1.7)	(0-1.7)	(0-1.7)
Connections	See pg. 49	See pg. 21	See pg. 37	See pg. 21
Finish	Stainless	Stainless	Stainless	Stainless
Base Construction	Stainless Steel Footring	Round Caster	Stainless Steel Footring	Round or Square Caster

Notes:

- ^{*} At lower relief valve settings, weights and capacities are higher (See Fill Weight Table)
- Peaks of up to 4 X continuous flow rates can be sustained for 5 minutes if the vaporizer coils are allowed to thaw in between.
- [†] Height may vary on caster base models depending on specified wheel diameter.
With optional pressure builder.

7

THEORY OF OPERATION

General

The various liquid cylinders of the Dura-Cyl/Cryo-Cyl Series have the same general operating characteristics. Each model of liquid cylinder has the ability to be filled with a cryogenic product, build pressure inside the vessel, and deliver either liquid or gas for a specific application.

The following section will discuss the theory behind these operations. Later sections (section 8 thru 13) will give a step by step procedure for the operation on each specific models of liquid cylinder.

Liquid cylinder operation is done completely with the control valves located on the top of the tank. The valves are labeled and color coded for easy identification: Fill/Liquid Valve – blue; Gas Use Valve – green; Vent Valve – silver; Pressure Building Valve – green.

The schematic, illustrations and table (figure M) show how the plumbing circuitry operates for the four major models of liquid cylinders. It is important that the operators be familiar with the plumbing control valves and there functions.

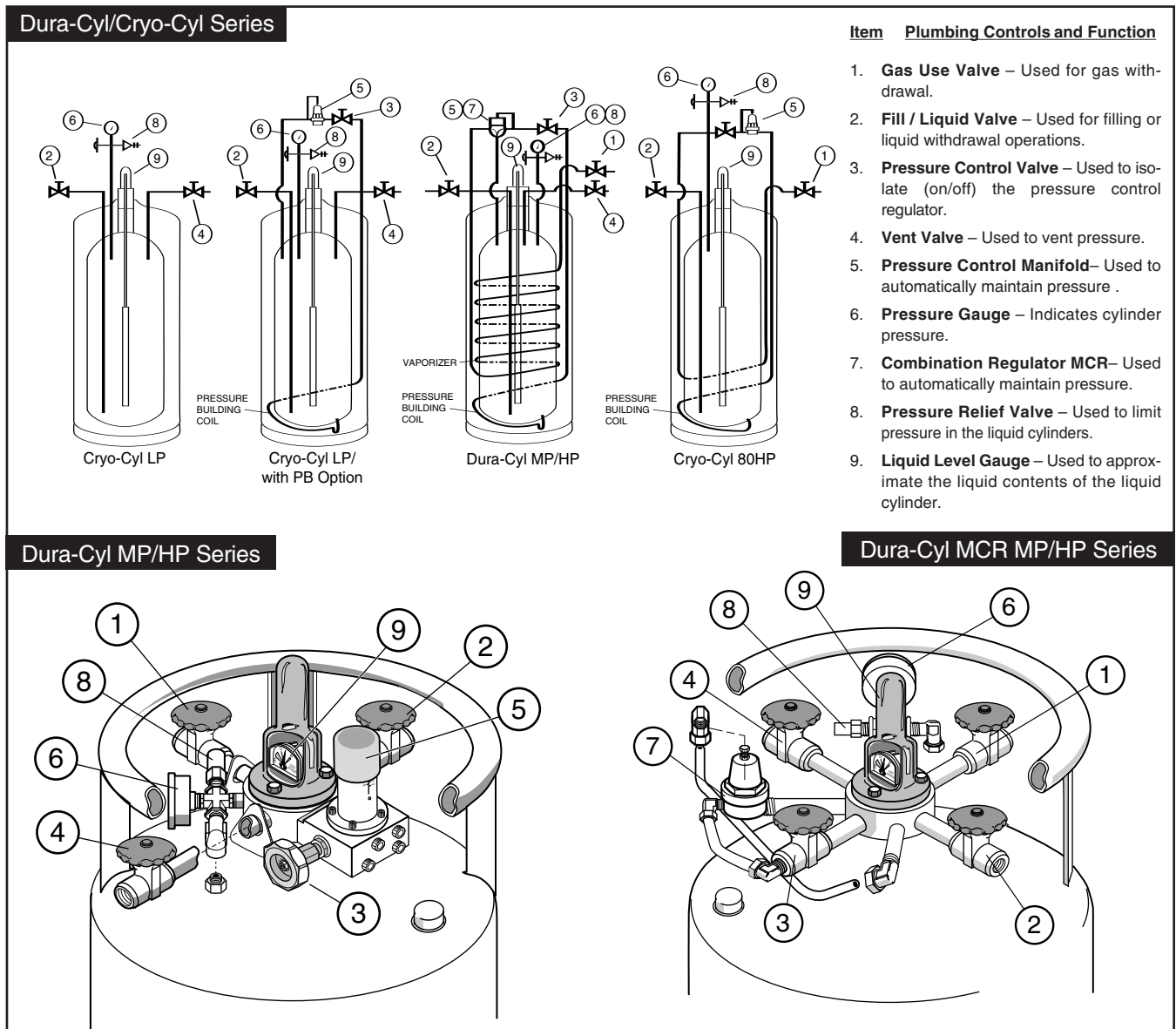

Figure M

Filling Procedures

The following recommendations should be used to optimize liquid cylinder filling:

- * Keep the transfer lines as short as possible. Long uninsulated transfer lines will result in higher fill losses and longer fill times.
- * Anytime liquid can be entrapped in a line between two valves, the line must be equipped with a safety relief device.
- * Conduct the filling operation in as short a time as possible.
- * Do not over fill; fill only to the weight allowable by specification.
- * Use a minimum number of bends, valves and reducers.
- * Use as large a transfer line as possible – at least 1/2" ID.

Chart recommends the "Lo-Loss" system for liquid cylinder filling. For information ask for Form 2072 on the "Lo-Loss" from Chart.

The liquid cylinder should be visually inspected before every fill for possible damage, cleanliness and suitability for its intended gas service. If damage is detected (e.g. serious dents, loose fittings, etc.) remove it from service and repair the unit as soon as possible.

All Chart liquid cylinders are tested for performance with low-purity liquid nitrogen. For this reason liquid cylinders intended for use in another service should be thoroughly purged with the applicable gas prior to filling.

When filling a liquid cylinder with a cryogenic liquid, the transfer may be made with a centrifugal pump or through a pressure transfer operation.

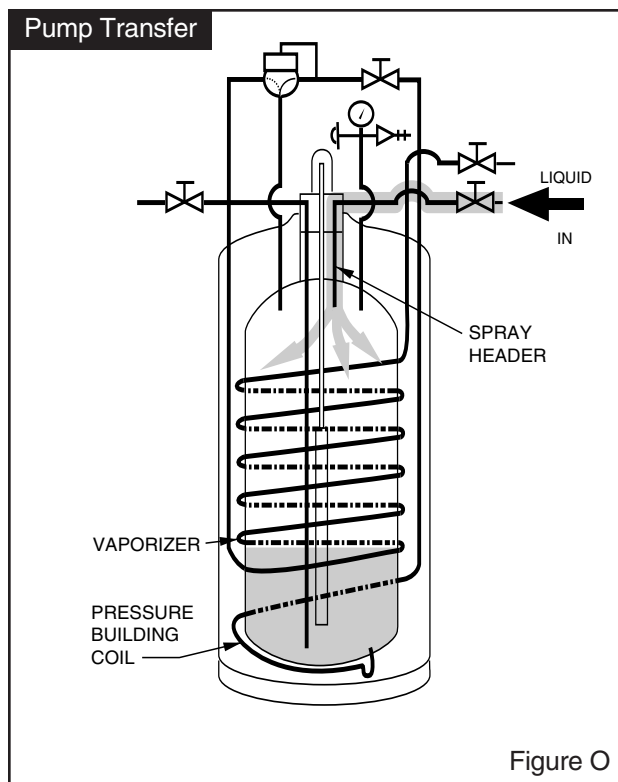
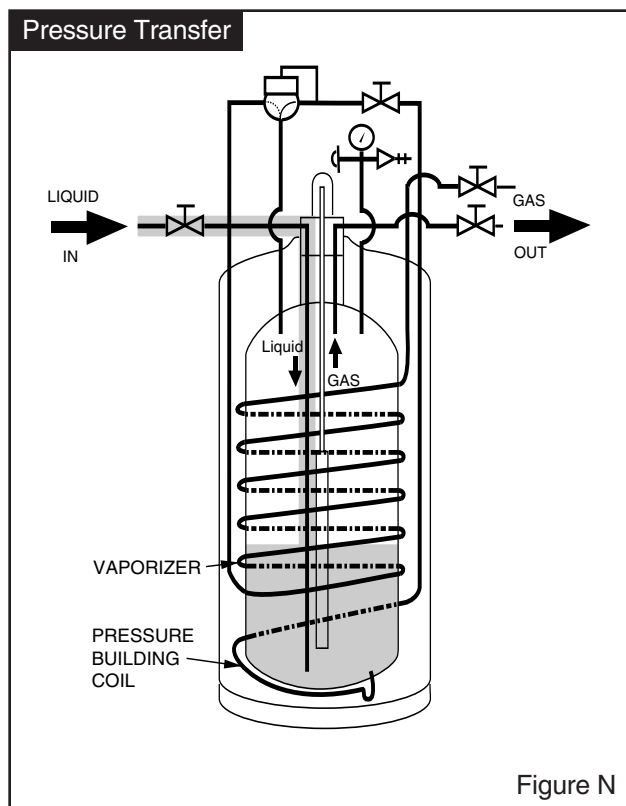

Pressure Transfer

Liquid will always flow from a vessel of higher pressure to one with low pressure. This method is commonly used to fill liquid cylinders by connecting a transfer line between the delivery source and the Fill/Liquid valve of the liquid cylinder. The transfer takes place as the vent valve of the liquid cylinder is opened. This allows gas to escape and lowers the pressure in the liquid cylinder. This method should always be used for liquid only vessels such as the Cryo-Cyl LP. Figure N shows the pressure transfer method of filling.

7 THEORY OF OPERATION

Pump Transfer

The pump transfer method lowers the product losses associated with filling. Liquid may be pumped into the cylinder so that venting is not necessary. The vent valve on the liquid cylinder has a spray header that will splash the incoming cold liquid onto the somewhat warmer gas in the tank. The cold liquid will actually collapse the vessel pressure while being sprayed into the warmer gas. This method of filling works well with vessels that are used regularly and do not warm up between fills. Figure O shows the pump transfer method.

Gas Withdrawal

When a Dura-Cyl liquid cylinder is used for gas withdrawal, the normal operating pressure range is from approximately 75-175 psig and the pressure relief valve has a set pressure of 230 psig. When a Dura-Cyl HP liquid cylinder is used for gas withdrawal, the normal operating pressure range is from approximately 100-350 psig and the pressure relief valve has a set pressure of 350 psig. On both liquid cylinders the economizer portion of the control regulator is automatically set approximately 15 psig higher than the pressure building portion of the control regulator.

WARNING: Before conducting a gas (or liquid) withdrawal operation, make sure protective eye-glasses and gloves are being used.

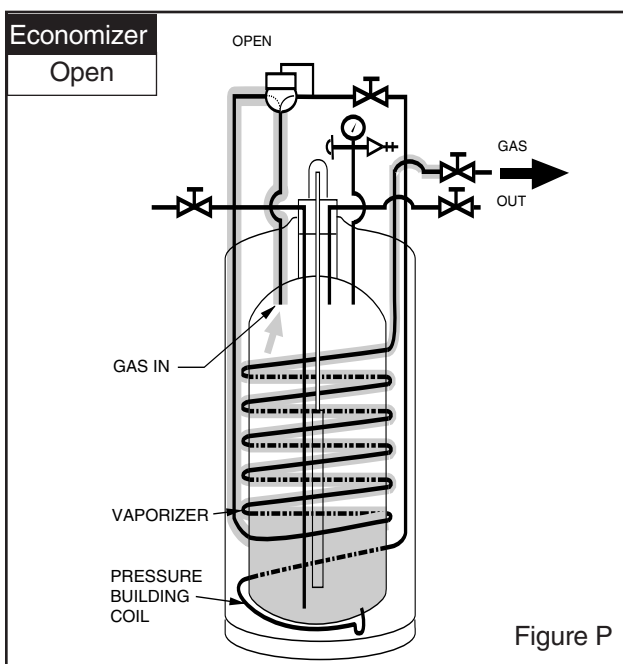

Figure P

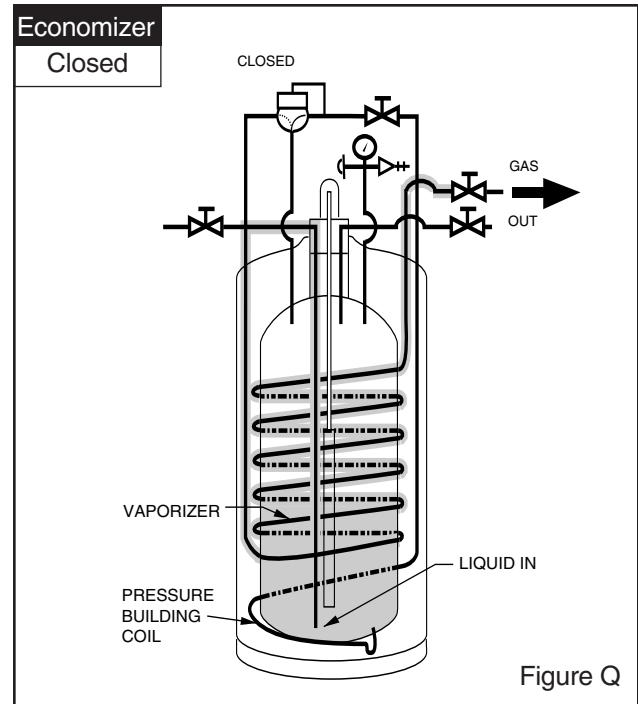
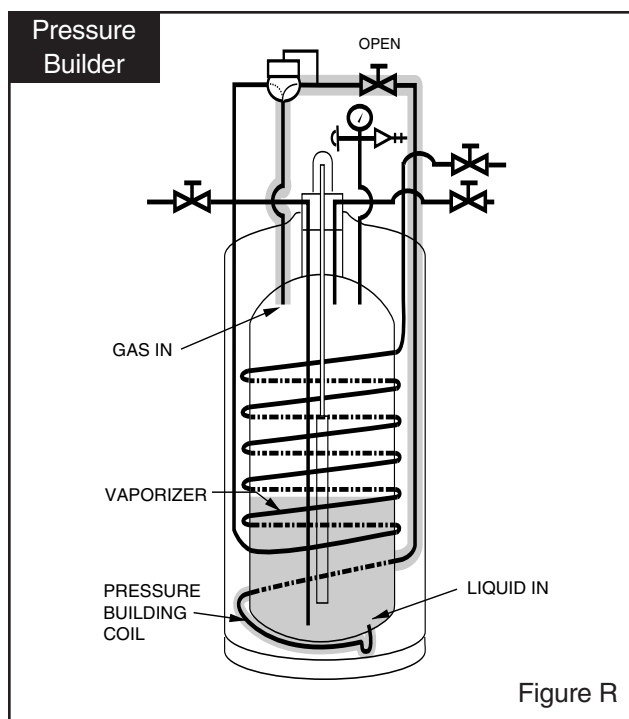

Figure Q

The supply of gaseous product is the primary operation of the liquid cylinder. An additional regulator must be added to the gas use valve to step down the pressure to the application. The liquid cylinder is usually at a high pressure after the filling and delivery operation. When it is connected to the gas application and the gas use valve and pressure building valves are opened, it will automatically deliver gas.

The Dura-Cyl MP/Dura-Cyl MCR MP model with a 230 psi relief valve operates between the pressure building setting (125 psig) and the economizer setting (140 psig). When the operating pressure is above the economizer setting (140 psi) the regulator will open (Figure P). The gas that is being supplied to the application will be pulled out of the vapor space in the top of the tank. It will travel through the regulator and then the vaporizer coils. It will be warmed before it reaches the final line regulator. The action of removing gas from the tank reduces the tanks pressure.

When the operating pressure is reduced to the economizer setting (140 psi), the regulator will close (Figure Q). Gas is still required by the application and will pull liquid up the dip tube and into the vaporizer. This will turn the liquid into gas and warm it before it is delivered to the final line regulator. The pressure decay will be much slower since a small amount of liquid can be vaporized into a large amount of gas.



When the pressure falls below the pressure building regulator setting (125 psi), the regulator will open (Figure R). This will allow liquid to run into the pressure builder vaporizer located at the bottom of the tank. The liquid will turn into gas and be delivered back into the top vapor space of the tank. The results of this operation is a rise in pressure in the tank.

Liquid Withdrawal

If the liquid cylinder is to be placed in permanent liquid withdrawal service, it is recommended that the cylinder be refitted with a 22 psig relief valve to minimize loss due to flash-off.

Note:

In a Dura-Cyl HP/Cryo-Cyl HP the pressure must be kept above 70 psig for CO₂ to prevent solidifying the CO₂.

CAUTION: Before making a liquid transfer, be sure that protective eye glasses and gloves are being worn.

To withdraw liquid from a liquid cylinder, connect a transfer line from the liquid valve fitting to the user's receiving vessel (Figure S). Open the liquid valve to obtain the preferred rate of flow. Close the liquid valve when the user's vessel has been filled. To prevent contamination, when the cylinder has been emptied, all valves should be closed. To minimize flash-off and spillage, use a phase separator on the end of the trans-

fer line. Normal liquid withdrawal operations are performed at lower pressure (approximately 22 psig) to reduce flash-off losses and splashing. For this reason, the pressure building valve is customarily closed during liquid withdrawals. Transfer of liquid at higher pressures can lead to excessive splashing of the cryogenic liquid which could result in burns to the operator and/or nearby personnel. All personnel should be fully instructed in the cautions associated with handling cryogenic fluids and the proper clothing and protective gear to be used.

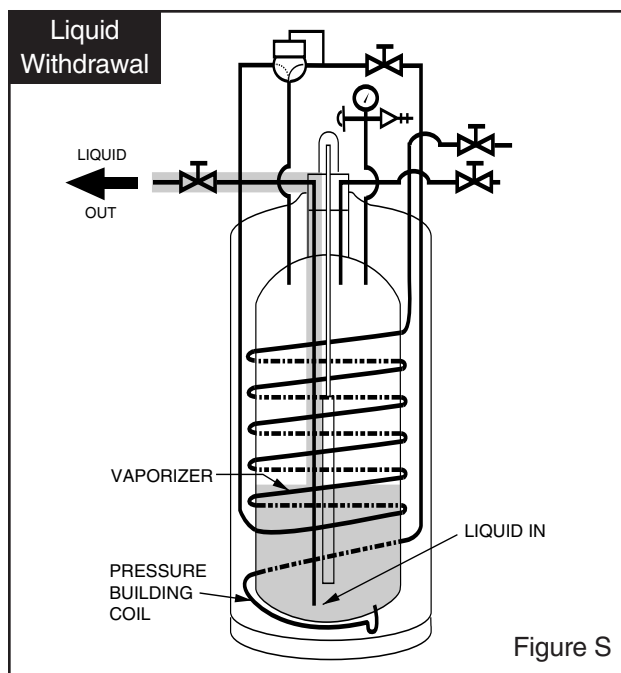

If a higher operating pressure is desired (other than that available through normal heat leak), the pressure building valve may be opened for a short time until the preferred pressure has been obtained. If automatic pressure building for liquid service is necessary, a low pressure building regulator may be installed to replace the pressure building regulator supplied with the unit.

Liquid carbon dioxide, used for freezing or cooling can be completely withdrawn from a Dura-Cyl HP/Cryo-Cyl HP liquid cylinder, leaving just 2% residual gaseous product. Connect a transfer line from the liquid fitting of the liquid cylinder to the receiving vessel. Open the liquid valve to obtain the desired rate of flow.

The Dura-Cyl HP/Cryo-Cyl HP will deliver a continuous flow of liquid CO₂ at rates of 1,000 pounds/hour or greater, having a refrigeration content of 119 BTU/pound at 350 psig. Leave the pressure building valve open for high withdrawal rates.

8

OPERATION OF CRYO-CYL 120 / 180 / 230 LP

General

The Cryo-Cyl 120/180/230 LP cryogenic liquid cylinders have been designed to transport, store and dispense liquid oxygen, nitrogen or argon in their liquid states only. Liquid product is generally used at ambient or very low pressures. The Cryo-Cyl LP has a working pressure of 22 psig (1.5 BAR)to allow for transfer into vented cryogenic dewars or equipment. The pressure is maintained in the liquid cylinder

through its normal heat leak of the cylinder. The pressure will rise in the closed cylinder as its liquid contents boil off. It is normal for the pressure to reach the relief valve setting of 22 psi (1.5 BAR) and vent slowly into the atmosphere. The transportation of the cryogenic products in these liquid cylinders is not regulated by the DOT/TC since the pressure is normally below 25 psi (1.7 bar).

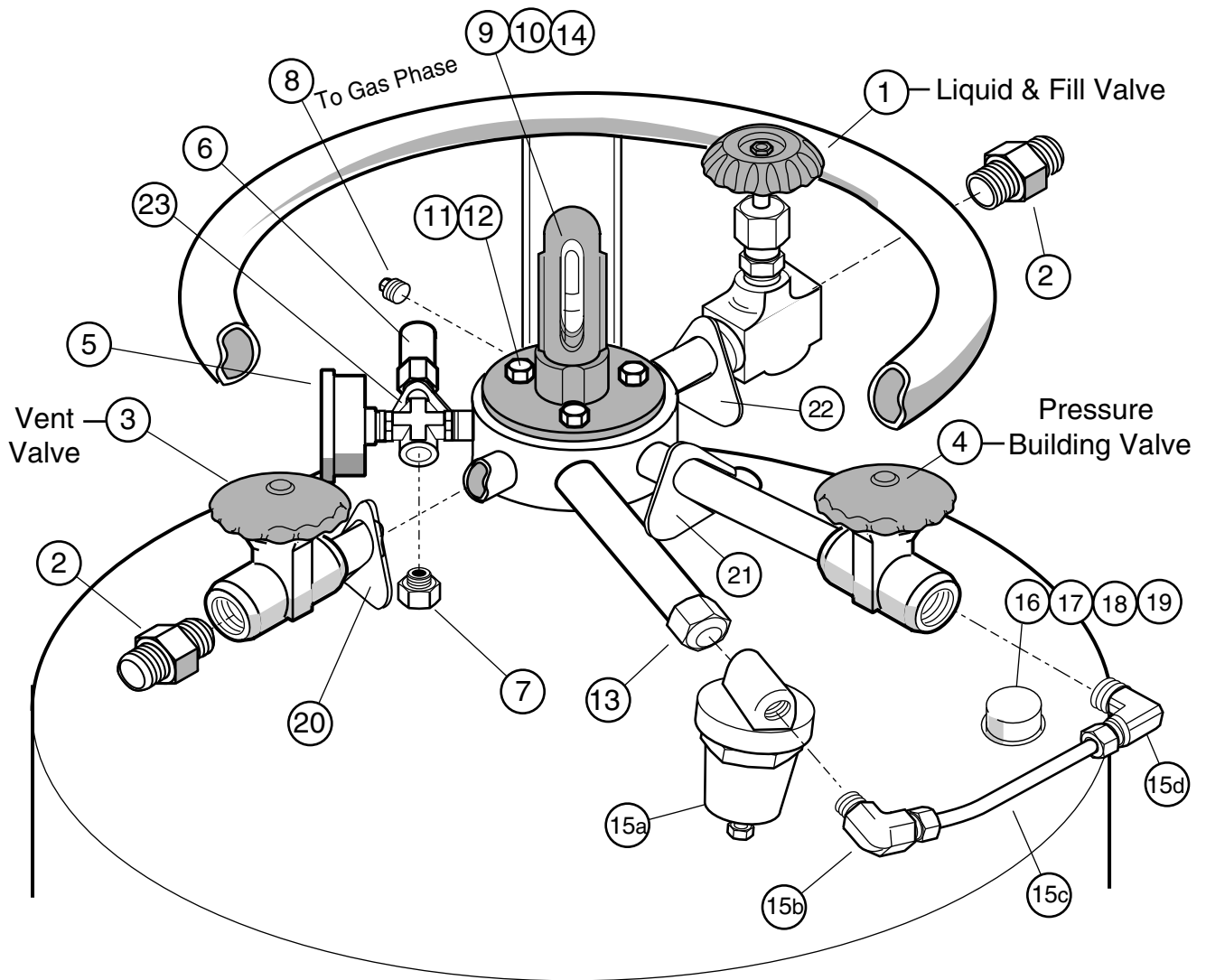

OPERATION OF CRYO-CYL 120 / 180 / 230 LP

8

Item	Part No	Qty	Spares *	Description
1	11769595	1		Globe Valve – 3/8" FPT (Liquid) (Blue)
2	1110072	2	1	Male Connector – 1/2" ODT X 3/8" MPT (Argon or Nitrogen)
2	1110112	2	1	Male Connector – 5/8" ODT X 3/8" MPT (Oxygen)
3	11905956	2		Globe Valve – 3/8" FPT (Vent)
4	11692575	1		Globe Valve – 3/8" FPT (P.B.)
5	2015169	1	1	Pressure Gauge (0-100 psi)
6	11884770	1	1	Relief Valve (22 psi)
7	1911622	1	1	Rupture Disc (200 psi)
8	1211102	1		Brass Plug – 1/4" MPT
9	2300094	1	1	O-ring (silicon) Liquid Level Gauge
10	5410486	1	1	Level Gauge Protector (Yellow)
11	2910501	3		Bolt – 1/4-20 X 5/8" Lg. (S.S.)
12	2910601	3		Lockwasher – 1/4" (S.S.)"
13	1210752	1		Brass Cap – 1/4" FPT
14	10658826	1	1	Level Gauge (see pg 63)
15	10658826	–		Pressure Building Regulator Kit (OPTIONAL)
15a	10582809	1		Pressure Building Regulator
15b	1011432	1		Male Elbow - 3/8" OD x 1/4" MPT
15c	8512163	1		Copper Tubing - 3/8" ODT-5"
15d	1011442	1		Male Elbow - 3/8" OD x 3/8" MPT
16	11732629	1		Pump-Out Body
17	11732637	1		Pump-Out Plug
18	2300059	2		O-ring, Pump-Out Plug
19	3911217	1		Dust Cap, Pump-Out
20	3811609	1		Metal Tag – Vent
21	3811619	1		Metal Tag – Pressure Building
22	3811589	1		Metal Tag – Liquid
23	12967551	1		Metal Tag – Relief Valve

* Recommended spare parts

Pressure Building (Option)

The Cryo-Cyl LP is equipped with an internal pressure building coil and plumbing stubs for the optional PB valve and regulator. The following procedure should be used for maintaining pressure during liquid withdrawal if the pressure building option is part of the Cryo-Cyl LP cylinder.

1. Open the PB isolation valve (Item 3) prior to liquid withdrawal.

2. Allow the pressure to rise in the cylinder until the regulator shuts off the PB circuit.
3. Transfer liquid as described in this operational sheet.
4. Close the PB valve when liquid transfer is complete.

Filling Procedures

The Cryo-Cyl LP is equipped with a Liquid and Vent valve that are used for filling. Use a pressure transfer fill as the proper filling method for this style of cylinder. The delivery tank pressure should be as low as practical for the transfer to be efficient. Use the following procedure.

CAUTION: Before making a liquid transfer be sure that protective eyeglasses and gloves are being worn.

1. Sample the residual gas that is in the cylinder. Purge the cylinder if necessary to insure the proper purity.
2. Place the cylinder on the filling scale. Record the weight. Compare this weight to the registered tare weight on the data plate. The difference is the weight of the residual gas.
3. Connect the transfer hose to the fill valve (Item 1). Record the new weight. The difference between this weight and the initial weight is the weight of the transfer hose.
4. To determine the total filling weight add the tare weight of the cylinder, the hose weight and the proper filling weight from the table. The table indicates the product across the top and the liquid cylinder model down the side. Connect the two columns to find the proper weight. Example: The Cryo-Cyl 120 LP for oxygen at 22 psi (1.5 BAR) has a product weight of 285 pounds (129 Kg.).
5. Open the cylinders vent (Item 3) and liquid (Item 1) valves. Open the transfer line shut-off valve to begin the flow of product.

6. When the scale reads the calculated total filling weight, turn off the liquid valve (Item 1) on the cylinder. Close the vent valve (Item 3).
7. Close the transfer line shut-off valve and relieve the pressure in the transfer line. Remove the transfer line. Remove the cylinder from the scale.

CAUTION: The transfer hose will have pressure in it that must be relieved before the hose is completely removed.

Operating Pressure

The liquid cylinder will maintain a normal operating pressure of 22 psig (1.5 BAR). Normal liquid withdrawal operations are performed at lower pressure to reduce flash-off losses and splashing. Transfer of liquid at higher pressures can lead to excessive splashing of the cryogenic liquid which could result in burns to the operator and/or nearby personnel. All personnel should be fully instructed in the cautions associated with handling cryogenic fluids and the proper clothing and protective gear to be used.

Liquid Withdrawal

Cryogenic liquid can be pressure transferred from the liquid cylinder to other cryogenic equipment that operates at a lower pressure than the liquid cylinder. To make a liquid transfer follow this procedure:

CAUTION: Before making a liquid transfer be sure that protective eyeglasses and gloves are being worn. If the transfer is being made to an open top vessel, the transfer pressure should be as low as possible and a phase separator should be used to eliminate splashing and hose whip.

OPERATION OF CRYO-CYL 120 /180 / 230 LP

8

1. Connect the transfer hose to the liquid valve (Item 1) of the cylinder.
2. Connect or place the other end of the hose onto the inlet of the cryogenic equipment that will receive liquid. Atmospheric dewars are filled with a phase separator mounted to the open end of the hose.
3. Refer to the receiving equipment manual for procedures to open the fill valve and vent valve of the receiving equipment.
4. Open the liquid valve (Item 1) on the liquid cylinder. This valve can be adjusted to obtain the proper liquid flow rate.
5. When the transfer is complete, close the receiving equipment's valve. Close the liquid valve (Item 1) on the cylinder and relieve pressure from the hose.
6. Disconnect or remove the hose from the receiving equipment.

STANDARD FILLING WEIGHT TABLE

MODEL*	NITROGEN	OXYGEN	ARGON
Cryo-Cyl 120LP	201 Lbs.	285 Lbs.	351 Lbs.
Cryo-Cyl 180LP	327 Lbs.	465 Lbs.	573 Lbs.
Cryo-Cyl 230LP	401 Lbs.	570 Lbs.	702 Lbs.

METRIC FILLING WEIGHT TABLE

MODEL*	NITROGEN	OXYGEN	ARGON
Cryo-Cyl 120LP	91 Kg.	129 Kg.	159 Kg.
Cryo-Cyl 180LP	148 Kg.	211 Kg.	260 Kg.
Cryo-Cyl 230LP	182 Kg.	258 Kg.	318 Kg.

Note: Filling weights are shown as the maximum weight recommended by code. Their related volumes may vary with product density.

* Relief valve setting at 22 psig (1.5 BAR)

General

This section of the manual deals with the Dura-Cyl MCR 160 MP, Dura-Cyl MCR 180 MP, Dura-Cyl MCR 200 MP, Dura-Cyl MCR 230 MP and Dura-Cyl MCR 265 MP. They will be referred to in this section as liquid cylinders. These liquid cylinder models are functionally the same and only vary in capacity. They are designed to transport, store and delivery liquid oxygen, nitrogen or argon as a cryogenic liquid or gas. The common application for these liquid cylinders is to provide gas at pressures around 100 psi (6.9 bar). The liquid cylinder will build and maintain pressure at the pressure control regulator

setting of 125 psi (8.6 bar). If the pressure exceeds 140 psi (9.7 bar) the economizer portion of the regulator will supply gas to the receiving equipment to reduce the cylinder pressure. A continuous gas flow can be automatically provided from these cylinders.

Liquid can be withdrawn from these liquid cylinders in the same manner that was described in section 8 Cryo-Cyl LP.

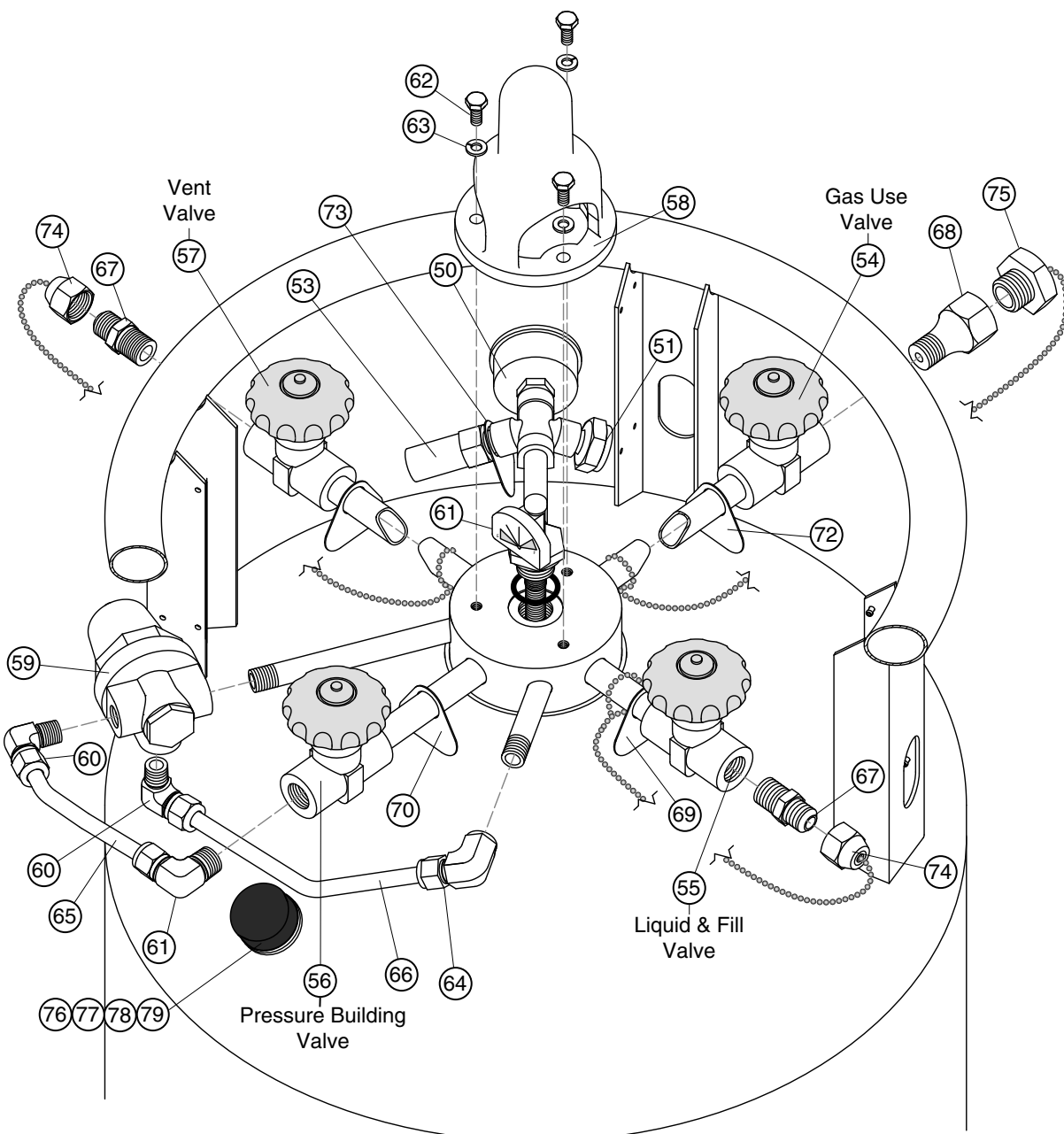

Item	Part No	Qty	Spares *	Description
50	2015179	1	1	Pressure Gauge (0-400 psig/27.6 BAR)
51	1910882	1	1	Safety Rupture Disc – 1/4" MPT (400 psig/27.6 BAR)
53	11884796	1	1	Pressure Relief Valve (230 psig/15.9 BAR)
54	11905964	1		Globe Valve – 3/8" FPT (Gas Use) (Green)
55	11906043	1		Globe Valve – 3/8" FPT (Liquid Fill) (Blue)
56	11905964	1		Globe Valve – 3/8" FPT (Pressure Building) (Green)
57	11905956	1		Globe Valve – 3/8" FPT (Vent) (Silver)
58	10534583	1	1	Level Gauge Protector (Blue)
59	11081336	1	1	Regulator Combination PB/Economizer 1/4" (125 psi/8.6 BAR)
60	1011432	2		90° Elbow – 3/8" OD X 1/4" MPT
61	–	1		Liquid Level Indicator (see page 64)
61	1011442	1		Male Elbow – 3/8" OD X 3/8" MPT
62	2910501	3		Bolt – 1/4"-20 (S.S.)
63	2910601	3		Lockwasher – 1/4"
64	1213152	1		90° Elbow – 3/8" OD x 1/4" FPT
65	8512163	1		Copper Tube – 3/8" ODT-5"
66	10590999	1		Copper Tube – 3/8" OD X 7"
67	1110072	2	1	Male Connector – CGA 295 – 1/2" ODT X 3/8" MPT (Ar or N)
67	1110112	2	1	Male Connector – CGA 440 – 5/8" ODT X 3/8" MPT (Oxygen)
68	4010022	1	1	Gas Outlet – 3/8" MPT X CGA – 580 (Ar or N)
68	4010012	1	1	Gas Outlet – 3/8" MPT X CGA – 540 (O ₂)
69	3811589	1		Metal Tag (Liquid/Fill)
70	3811619	1		Metal Tag (Pressure Building)
71	3811609	1		Metal Tag (Vent)
72	3811599	1		Metal Tag (Gas Use)
73	12967551	1		Metal Tag – Relief Valve
74	4016639	2		Dust Cap 1/2" – ODT Ar or N (optional)
74	4016649	2		Dust Cap 5/8" – ODT O ₂ (optional)
75	4010629	1		Dust Cap – Ar or N (optional)
75	4010512	1		Dust Cap – O ₂ (optional)
76	11732629	1		Pump-Out Body
77	11732637	1		Pump-Out Plug
78	2300059	2		O-ring, Pump-Out Plug
79	3911217	1		Dust Cap, Pump-Out

* Recommended spare parts.

Filling Procedures

The liquid cylinder is regulated by the US DOT/Transport Canada for transporting liquid oxygen, nitrogen or argon. The filling of these liquid cylinders must be done by product weight. This will allow enough gas space above the liquid to keep the liquid cylinder from becoming liquid full if its pressure rises to the relief valve setting. The filling weight table (pgs 29 & 30) indicates the correct product weight for the various relief valve settings. The standard relief valve setting is 230 psig.(15.9 bar). The filling procedure will show the proper way to use the filling weight table.

The liquid cylinder is equipped with a liquid and vent valve that are used during the filling procedure. The liquid valve is equipped with a dip tube that extends into the inner vessel of the cylinder and reaches to the bottom. The vent valve has a vent tube attached to it that also extends into the inner vessel of the cylinder. This vent tube is designed to spray the liquid into the top of the vessel so that pump filling through the vent valve will keep head pressure down in the cylinder.

Filling can be accomplished by either pressure transfer or pump fill. The following procedure should be used, refer to the illustration on page 25:

1. Sample the residual gas that is in the cylinder. Purge the cylinder (refer to the purging procedure, page 58) if necessary to insure the proper purity.
2. Place the cylinder on the filling scale. Record the weight. Compare this weight to the registered tare weight on the data plate. The difference is the weight of the residual gas.
3. Connect the transfer hose to the liquid valve (Item 56). Record the new weight. The difference between this weight and the initial weight is the weight of the transfer hose.
4. To determine the total filling weight add the tare weight of the cylinder, the hose weight and the proper filling weight from the table (pg 29). The table indicates the product across the top and the relief valve pressure down the side. Connect the two columns to find the proper weight. Example: Dura-Cyl MCR 160 MP for Oxygen at 230 psi has a product weight of 379 pounds.
5. Open the cylinders vent (Item 58) and liquid valves (Item 56). Open the transfer line shut-off valve to begin the flow of product.
6. When the scale reads the calculated total filling weight turn off the liquid valve (Item 56) on the cylinder. Close the vent valve (Item 58).
7. Close the transfer line shut-off valve and relieve the pressure in the transfer line. Remove the transfer line. Remove the cylinder from the scale.

Operating Pressure

The liquid cylinder will automatically maintain a normal operating pressure between the pressure building portion of the regulator (125 psi- 8.6 bar) and the economizer portion of the regulator (140 psi- 9.7 bar). The operating pressure can be set up or down by simply adjusting the regulator while watching the pressure gauge. The adjustment range of the regulators is between 50 and 175 psi (3.4 and 12.1 bar).

The gas delivery pressure should not be confused with the vessel operating pressure. The gas delivery pressure should be adjusted with a separate regulator that is attached to the gas withdrawal fitting (Item 71).

Gas Withdrawal

The liquid cylinder will deliver gas at various flow rates and temperatures (as shown in Table J1, page 13) for different applications. The flow rate is controlled by the equipment that is being supplied gas from the liquid cylinder. The continuous flow rate (as shown in the specification – page 14-16) indicates the flow rate that will normally provide gas at a reasonable temperature and should not be exceeded. Higher flow rates may provide very cold gas that could damage the equipment that they are attached to. To supply gaseous product follow this step by step procedure:

1. Connect the proper regulator to the liquid cylinders gas use outlet (Item 71).
2. Connect the proper hose between the final line regulator and the receiving equipment.
3. Open the pressure building valve (Item 57).
4. Allow pressure (refer to gauge – Item 50) to build to the operating pressure of 140 psi (9.7 BAR).
5. Open the gas use valve (Item 55).
6. Adjust the gas use regulator for the proper delivery pressure.
7. When the gas delivery is completed, close all liquid cylinder valves.

CAUTION: The liquid and vent valves on an empty liquid cylinder should always be kept closed to protect the inner vessel and plumbing from being contaminated.

Service and Maintenance

Refer to section 15 and 16 of this manual to trouble shoot problems and service these liquid cylinders.

9

OPERATION OF DURA-CYL MCR 160 / 180 / 200 / 230 / 265MP

STANDARD FILLING WEIGHT TABLE

RELIEF VALVE Setting (PSIG)	ARGON		NITROGEN		OXYGEN	
	LBS	SCF	LBS	SCF	LBS	SCF
DURA-CYL 160 MP (235 psig max. RV)						
Gross Cap = 176 Liters						
0 to 45	514	4971	294	4058	418	5048
46 to 75	503	4864	286	3947	406	4903
76 to 105	491	4748	278	3837	398	4807
106 to 170	472	4564	271	3740	387	4674
**171 to 230	460	4448	267	3685	379	4577
231 to 235	445	4303	263	3630	371	4480
DURA-CYL 180 MP (235 psig max. RV)						
Gross Cap = 196 Liters						
0 to 45	573	5541	327	4513	465	5616
46 to 75	560	5415	319	4403	452	5459
76 to 105	547	5290	310	4278	444	5362
106 to 170	526	5086	301	4154	431	5205
**171 to 230	513	4961	297	4099	422	5096
231 to 235	495	4787	293	4044	413	4988
DURA-CYL 200 MP (235 psig max. RV)						
Gross Cap = 209 Liters						
0 to 45	611	5908	349	4817	496	5990
46 to 75	597	5773	340	4693	482	5821
76 to 105	583	5638	331	4568	473	5712
106 to 170	560	5415	321	4430	459	5543
**171 to 230	547	5290	317	4375	450	5435
231 to 235	528	5106	312	4306	441	5326
DURA-CYL 230 MP (235 psig max. RV)						
Gross Cap = 240 Liters						
0 to 45	702	6789	401	5535	570	6884
46 to 75	686	6634	390	5383	554	6691
76 to 105	670	6479	380	5245	543	6558
106 to 170	644	6228	369	5093	528	6377
**171 to 230	628	6073	364	5024	517	6244
231 to 235	607	5870	359	4955	506	6111
DURA-CYL 265 MP (235 psig max. RV)						
Gross Cap = 276 Liters						
0 to 45	807	7804	461	6363	655	7911
46 to 75	789	7630	449	6197	637	7693
76 to 105	771	7456	437	6031	625	7548
106 to 170	740	7156	425	5866	607	7331
**171 to 230	722	6982	418	5769	595	7186
231 to 235	698	6750	412	5686	582	7029

Note: Filling weights are shown as the maximum weight allowed by code. Their related volumes may vary with product density.

** Normal Factory Setting

METRIC FILLING WEIGHT TABLE						
RELIEF VALVE Setting (BAR)	ARGON		NITROGEN		OXYGEN	
	KG	NM ³	KG	NM ³	KG	NM ³
DURA-CYL 160 MP (16 bar max. RV) Gross Cap = 176 Liters						
0 to 3.1	233	130	133	106	190	133
3.2 to 5.2	288	161	130	104	184	129
5.3 to 7.2	223	125	126	101	180	126
7.3 to 11.7	214	120	123	98	176	123
**11.8 to 15.9	209	117	121	97	172	120
16.0 to 20.3	202	113	119	95	168	117
DURA-CYL 180 MP (16 bar max. RV) Gross Cap = 196 Liters						
0 to 3.1	260	146	148	118	211	148
3.2 to 5.2	254	142	145	116	205	143
5.3 to 7.2	248	139	141	113	201	141
7.3 to 11.7	239	134	137	109	195	136
**11.8 to 15.9	233	130	135	108	191	134
16.0 to 20.3	224	125	133	106	187	131
DURA-CYL 200 MP (16 bar max. RV) Gross Cap = 209 Liters						
0 to 3.1	277	155	158	126	225	157
3.2 to 5.2	271	152	154	123	219	153
5.3 to 7.2	264	148	150	120	215	150
7.3 to 11.7	254	142	146	117	208	145
**11.8 to 15.9	248	139	144	115	204	143
16.0 to 20.3	239	134	141	113	200	140
DURA-CYL 230 MP (16 bar max. RV) Gross Cap = 240 Liters						
0 to 3.1	318	178	182	149	258	180
3.2 to 5.2	311	174	177	141	251	176
5.3 to 7.2	304	170	172	137	246	172
7.3 to 11.7	292	164	167	133	239	167
**11.8 to 15.9	285	160	165	132	234	164
16.0 to 20.3	275	154	163	130	229	160
DURA-CYL 265 MP (16 bar max.) Gross Cap = 276 Liters						
0 to 3.1	366	205	209	167	297	208
3.2 to 5.2	358	201	204	163	289	202
5.3 to 7.2	350	196	198	158	283	198
7.3 to 11.7	336	188	193	154	275	192
**11.8 to 15.9	327	183	190	152	270	189
16.0 to 20.3	317	178	187	149	264	185

Note: Filling weights are shown as the maximum weight allowed by code. Their related volumes may vary with product density.

** Normal Factory Setting

10

OPERATION OF DURA-CYL 160/180/200/230/265 MP

General

This section of the manual deals with the Dura-Cyl MP model liquid cylinder. The Dura-Cyl MP liquid cylinder has the unique feature of a combination pressure building and economizer regulator (known as the "LCCM- liquid cylinder control manual"). The LCCM eliminates the need to adjust two regulators when the operating pressure needs to be changed. The Dura-Cyl MP is designed to transport, store and deliver liquid oxygen, nitrogen or argon as a cryogenic liquid or gas. The common application for this liquid cylinder is to provide gas at pressures around 100 psi (6.9 bar).

The liquid cylinder will build and maintain pressure at the regulator setting of 125 psi (8.6 bar). If the pressure exceeds 140 psi (9.7 bar) the regulator will supply gas from the tank vapor space to the receiving equipment which will reduce the cylinder pressure. A continuous gas flow can be automatically provided from this cylinder.

Liquid can be withdrawn from this liquid cylinder in the same manner that was described in section 8.0 Cryo-Cyl LP.

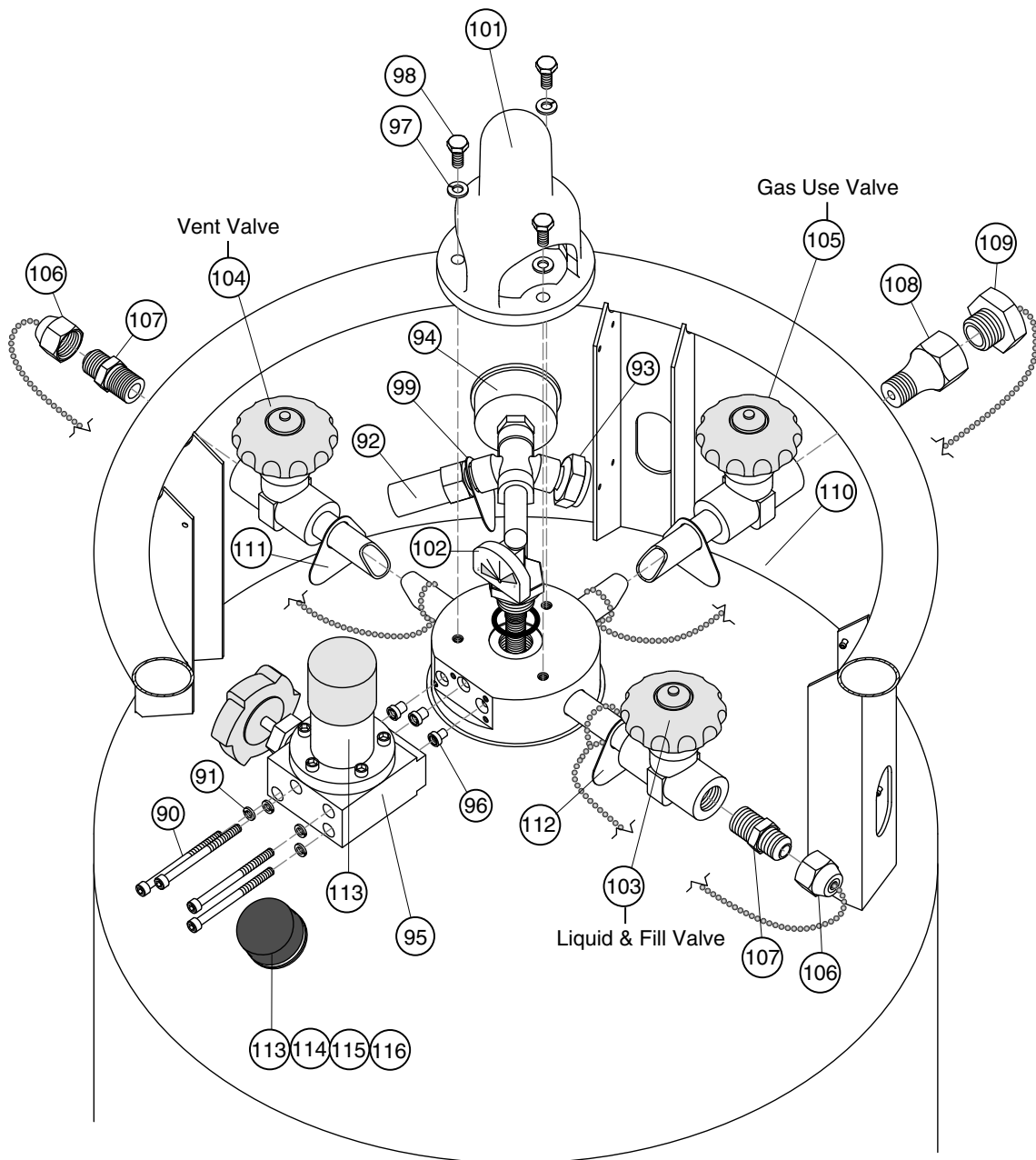

Item	Part No.	Qty.	Spares *	Description
90	11534542	4	4	Bolt SS # 10-32 x 2.5"
91	2911071	4	4	Washer Split Lock #10 SS
92	11884796	1	1	Pressure Relief Valve – 1/4" MPT (230 psi/ 15.9 BAR)
93	1910882	1	1	Rupture Disc – 1/4" MPT (400 psi/ 27.6 BAR)
94	2015179	1	1	Pressure Gauge – 1/4" CBM (0-400 psi/ 27.6 BAR)
95	11077134	1	1	LCCM Regulator – 125 set pressure
96	10951539	1	1	Knuckle Seal Kit
97	2910601	3		Lockwasher – 1/4" (SS)
98	2910501	3		Screw – 1/4-20 (SS)
99	12967551	1		Metal Tag – Relief Valve
101	10534583	1	1	Sight Gauge Protector (Blue)
102	–	1		Liquid Level Indicator (See Page 63)
103	11906043	1		Globe Valve – 3/8" NPT (Liquid Fill) (Blue)
104	11905956	1		Globe Valve – 3/8" NPT (Vent) (Silver)
105	11905964	1		Globe Valve – 3/8" NPT (Gas Use) (Green)
106	4016639	2		Dust Cap – 1/2" ODT (Argon or Nitrogen) (Optional)
106	4016649	2		Dust Cap – 5/8"ODT (Oxygen) (Optional)
107	1110072	2	1	Male Connector – 1/2" ODT X 3/8" MPT (Argon or Nitrogen)
107	1110112	2	1	Male Connector – 5/8" ODT X 3/8" MPT (Oxygen)
108	4010022	1	1	Gas Outlet – 3/8" MPT (Argon or Nitrogen)
108	4010012	1	1	Gas Outlet – 3/8" MPT (Oxygen)
109	4010629	1		Dust Cap (Argon or Nitrogen)
109	4010512	1		Dust Cap (Oxygen)
110	3811599	1		Metal Tag (Gas Use)
111	3811609	1		Metal Tag (Vent)
112	3811589	1		Metal Tag (Liquid)
113	11732629	1		Pump-Out Body
114	11732637	1		Pump-Out Plug
115	2300059	2		O-rings, Pump-Out Plug
116	3911217	1		Dust Cap, Pump-Out

* Recommended spare parts.

Filling Procedures

The Dura-Cyl MP is regulated by the Department of Transportation (US DOT/Transport Canada) for transporting liquid oxygen, nitrogen or argon. The filling of this liquid cylinder must be done by product weight. This will allow enough gas space above the liquid to keep the liquid cylinder from becoming liquid full if its pressure rises to the relief valve setting. The filling weight table (pgs 35 & 36) indicates the correct product weight for the various relief valve settings. The standard relief valve setting is 230 psig (15.9 BAR). The filling procedure will show the proper way to use the filling weight table.

The Dura-Cyl MP is equipped with a liquid and vent valve that are used during the filling procedure. The liquid valve is equipped with a dip tube that extends into the inner vessel of the cylinder and reaches to the bottom. The vent valve has a dip tube attached to it that also extends into the inner vessel of the cylinder. This vent tube is designed to spray the liquid into the top of the vessel so that pump filling through the vent valve will keep head pressure down in the cylinder.

Filling can be accomplished by either pressure transfer or pump fill. The following procedure is for a pressure transfer fill, refer to the illustration on page 31.

1. Sample the residual gas that is in the cylinder. Purge the cylinder (refer to the purging procedure, page 58) if necessary to insure the proper purity.
2. Place the cylinder on the filling scale. Record the weight. Compare this weight to the registered tare weight on the data plate. The difference is the weight of the residual gas.
3. Connect the transfer hose to the fill valve (Item 103). Record the new weight. The difference between this weight and the initial weight is the weight of the transfer hose
4. To determine the total filling weight add the tare weight of the cylinder, the hose weight and the proper filling weight from the table (pg 35). The table indicates the product across the top and the relief valve pressure down the side. Connect the two columns to find the proper weight. Example: The Dura-Cyl 160 MP for Oxygen at 230 psi has a product weight of 379 pounds.
5. Open the cylinders vent (Item 104) and liquid (Item 103) valves. Open the transfer line shut-off valve to begin the flow of product.
6. When the scale reads the calculated total filling weight, turn off the liquid valve (Item 103) on the cylinder. Close the vent valve (Item 104).
7. Close the transfer line shut-off valve and relieve the pressure in the transfer line. Remove the transfer line. Remove the cylinder from the scale.

Operating Pressure

The liquid cylinder will automatically maintain a normal operating pressure between the pressure building portion of the LCCM (125 psi/ 8.6 BAR) and the economizer portion of the LCCM (140 psi/ 9.7 BAR). The operating pressure can be set up or down by simply adjusting the LCCM control knob (item B) while watching the pressure gauge. The adjustment range of the regulators is between 40 and 160 psi (2.8 and 11.0 BAR).

The gas delivery pressure should not be confused with the vessel operating pressure. The delivery pressure should be adjusted with a separate regulator that is attached to the gas withdrawal fitting.

Gas Withdrawal

The liquid cylinder will deliver gas at various flow rates and temperatures (as shown in Figure J1, page 13) for different applications. The flow rate is controlled by the equipment that is being supplied from the liquid cylinder. The continuous flow rate (as shown in the specification, pages 14-16) indicates the flow rate that will normally provide gas at a reasonable temperature and should not be exceeded. Higher flow rates may provide very cold gas that could damage the equipment attached to them.

To supply gaseous product follow this step by step procedure:

1. Connect the proper fill line regulator to the liquid cylinder's gas use outlet (Item 108).
2. Connect the proper hose between the final line regulator and the receiving equipment.
3. Open the pressure building valve (Item A).
4. Allow pressure (refer to gauge – Item 94) to build to the operating pressure (125 psi-8.6 BAR).
5. Open the gas use valve (Item 105).
6. Adjust the gas use regulator for the proper delivery pressure.
7. When the gas delivery is completed, close all liquid cylinder valves.

CAUTION: The liquid and vent valves on an empty liquid cylinder should always be kept closed to protect the inner vessel and plumbing from being contaminated.

Service and Maintenance

Refer to section 15 and 16 of this manual to trouble shoot problem, and service these liquid cylinders.

10

OPERATION OF DURA-CYL 160 / 180 / 200 / 230 / 265 MP

STANDARD FILLING WEIGHT TABLE

RELIEF VALVE Setting (PSIG)	ARGON		NITROGEN		OXYGEN	
	LBS	SCF	LBS	SCF	LBS	SCF
DURA-CYL 160 MP (235 psig max. RV)						
Gross Cap = 176 Liters						
0 to 45	514	4971	294	4058	418	5048
46 to 75	503	4864	286	3947	406	4903
76 to 105	491	4748	278	3837	398	4807
106 to 170	472	4564	271	3740	387	4674
**171 to 230	460	4448	267	3685	379	4577
231 to 235	445	4303	263	3630	371	4480
DURA-CYL 180 MP (235 psig max. RV)						
Gross Cap = 196 Liters						
0 to 45	573	5541	327	4513	465	5616
46 to 75	560	5415	319	4403	452	5459
76 to 105	547	5290	310	4278	444	5362
106 to 170	526	5086	301	4154	431	5205
**171 to 230	513	4961	297	4099	422	5096
231 to 235	495	4787	293	4044	413	4988
DURA-CYL 200 MP (235 psig max. RV)						
Gross Cap = 209 Liters						
0 to 45	611	5908	349	4817	496	5990
46 to 75	597	5773	340	4693	482	5821
76 to 105	583	5638	331	4568	473	5712
106 to 170	560	5415	321	4430	459	5543
**171 to 230	547	5290	317	4375	450	5435
231 to 235	528	5106	312	4306	441	5326
DURA-CYL 230 MP (235 psig max. RV)						
Gross Cap = 240 Liters						
0 to 45	702	6789	401	5535	570	6884
46 to 75	686	6634	390	5383	554	6691
76 to 105	670	6479	380	5245	543	6558
106 to 170	644	6228	369	5093	528	6377
**171 to 230	628	6073	364	5024	517	6244
231 to 235	607	5870	359	4955	506	6111
DURA-CYL 265 MP (235 psig max. RV)						
Gross Cap = 276 Liters						
0 to 45	807	7804	461	6363	655	7911
46 to 75	789	7630	449	6197	637	7693
76 to 105	771	7456	437	6031	625	7548
106 to 170	740	7156	425	5866	607	7331
**171 to 230	722	6982	418	5769	595	7186
231 to 235	698	6750	412	5686	582	7029

Note: Filling weights are shown as the maximum weight allowed by code. Their related volumes may vary with product density.

** Normal Factory Setting

METRIC FILLING WEIGHT TABLE						
RELIEF VALVE Setting (BAR)	ARGON		NITROGEN		OXYGEN	
	KG	NM ³	KG	NM ³	KG	NM ³
DURA-CYL 160 MP (16 bar max. RV)						
Gross Cap = 176 Liters						
0 to 3.1	233	130	133	106	190	133
3.2 to 5.2	288	161	130	104	184	129
5.3 to 7.2	223	125	126	101	180	126
7.3 to 11.7	214	120	123	98	176	123
**11.8 to 15.9	209	117	121	97	172	120
16.0 to 20.3	202	113	119	95	168	117
DURA-CYL 180 MP (16 bar max. RV)						
Gross Cap = 196 Liters						
0 to 3.1	260	146	148	118	211	148
3.2 to 5.2	254	142	145	116	205	143
5.3 to 7.2	248	139	141	113	201	141
7.3 to 11.7	239	134	137	109	195	136
**11.8 to 15.9	233	130	135	108	191	134
16.0 to 20.3	224	125	133	106	187	131
DURA-CYL 200 MP (16 bar max. RV)						
Gross Cap = 209 Liters						
0 to 3.1	277	155	158	126	225	157
3.2 to 5.2	271	152	154	123	219	153
5.3 to 7.2	264	148	150	120	215	150
7.3 to 11.7	254	142	146	117	208	145
**11.8 to 15.9	248	139	144	115	204	143
16.0 to 20.3	239	134	141	113	200	140
DURA-CYL 230 MP (16 bar max. RV)						
Gross Cap = 240 Liters						
0 to 3.1	318	178	182	149	258	180
3.2 to 5.2	311	174	177	141	251	176
5.3 to 7.2	304	170	172	137	246	172
7.3 to 11.7	292	164	167	133	239	167
**11.8 to 15.9	285	160	165	132	234	164
16.0 to 20.3	275	154	163	130	229	160
DURA-CYL 265 MP (16 bar max. RV)						
Gross Cap = 276 Liters						
0 to 3.1	366	205	209	167	297	208
3.2 to 5.2	358	201	204	163	289	202
5.3 to 7.2	350	196	198	158	283	198
7.3 to 11.7	336	188	193	154	275	192
**11.8 to 15.9	327	183	190	152	270	189
16.0 to 20.3	317	178	187	149	264	185

Note: Filling weights are shown as the maximum weight allowed by code. Their related volumes may vary with product density.

** Normal Factory Setting

11

OPERATION OF DURA-CYL MCR160 / 180 / 200 / 230 / 265 HP

General

This section of the manual deals with the Dura-Cyl MCR 160/180/200/230/265 HP. They will be referred to in this section as high pressure liquid cylinders. These high pressure liquid cylinder models are functionally the same and only vary in capacity. They are designed to transport, store and delivery liquid oxygen, nitrogen, argon, carbon dioxide, or nitrous oxide as a cryogenic liquid or gas. They can be used to transport liquid carbon dioxide or nitrous oxide in Canada with the

exemption Chart has received from Transport Canada. The common applications for these high pressure liquid cylinder is to provide gas at pressures around 300 psi or deliver liquid CO₂. The high pressure liquid cylinder will build and maintain pressure at the pressure control regulator setting of 300 psi (20.7 bar). If the pressure exceeds 325 psi (22.4 bar) the control regulator will supply gas from the tank vapor space to the receiving equipment which will reduce the cylinder pressure. A continuous gas flow can be automatically provided from these cylinders.

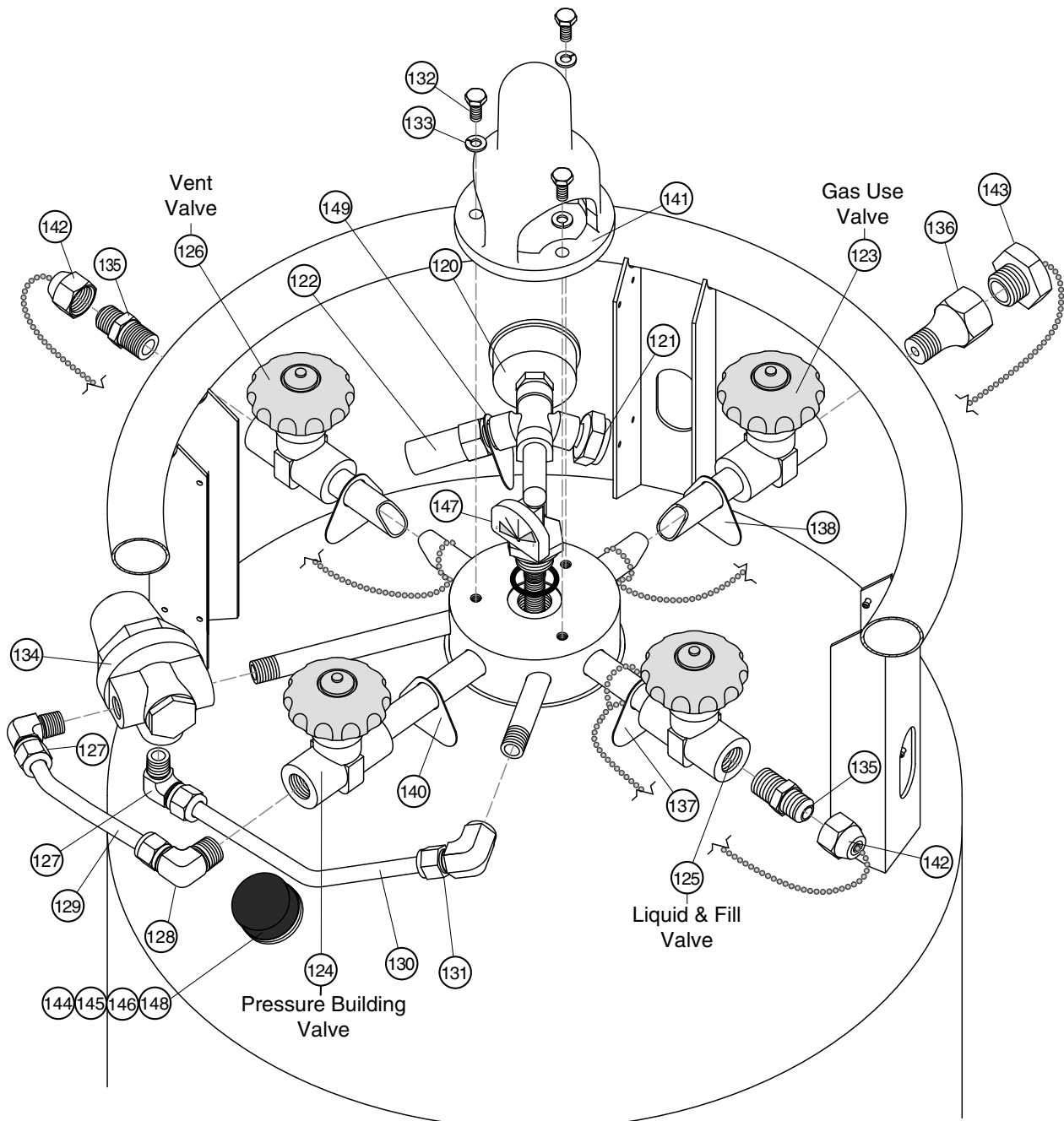

OPERATION OF DURA-CYL MCR 160/180/200/230/265 HP

11

Item	Part	Qty	Spares *	Description
120	2010064	1	1	Pressure Gauge (600 psig/ 41.4 BAR)
121	1911632	1	1	Safety Rupture Disc (600 psig/ 41.4 BAR)
122	11884788	1	1	Pressure Relief Valve – 1/4" MPT (350 psi/ 24.1 BAR)
123	11905964	1		Globe Valve – 3/8" FPT (Gas Use) (Green)
124	11905964	1		Globe Valve – 3/8" FPT (Pressure Builder) (Green)
125	11906043	1		Globe Valve – 3/8" FPT (Liquid Fill) (Blue)
126	11905956	1		Globe Valve – 3/8" FPT (Vent) (Silver)
127	1011432	2		Male Elbow – 3/8" OD X 1/4" MPT
128	1011442	1		Male Elbow – 3/8" OD X 3/8" MPT
129	8512163	1		Copper Tubing – 3/8" ODT – 5"
130	10590999	1		Copper Tubing – 3/8" ODT – 7"
131	1213152	1		90° Elbow – 3/8" ODT x 1/4" FPT
132	2910501	3		Bolt – 1/4-20 (SS)
133	2910601	3		Lockwasher — 1/4"
134	11081328	1	1	Regulator Combination PB/Economizer 1/4" (300 psi/20.7 BAR)
135	1110072	2	1	Male Connector – CGA 295 -1/2" ODT X 3/8" MPT (Ar or N)
135	1110112	2	1	Male Connector – CGA 440 -5/8" ODT X 3/8" MPT (O ₂)
136	4010022	1	1	Gas Outlet – 3/8" MPT X CGA-580 (Argon or Nitrogen)
136	4010012	1	1	Gas Outlet–3/8" MPT X CGA-540 (Oxygen)
137	3811589	1		Metal Tag (Liquid Fill)
138	3811599	1		Metal Tag (Gas Use)
139	3811609	1		Metal Tag Tag (Vent)
140	3811619	1		Metal Tag (Pressure Builder)
141	10534567	1	1	Sight Gauge Protector (Orange)
142	4016639	2		Dust Cap 1/2" ODT – Argon or Nitrogen (optional)
142	4016649	2		Dust Cap – 5/8" ODT O ₂ (optional)
143	4010629	1		Dust Cap –Ar or N (optional)
143	4010512	1		Dust Cap –O ₂ (optional)
144	11732629	1		Pump-Out Body
145	11732637	1		Pump-Out Plug
146	2300059	2		O-ring, Pump-Out Plug
147	–	1		Liquid Level Indicator (See Pg. 63)
148	3911217	1		Dust Cap, Pump-Out
149	12967551	1		Metal Tag - Relief Valve

* Recommended spare parts

Filling Procedures

The high pressure liquid cylinder is regulated by the DOT/Transportation Canada for transporting liquid oxygen, nitrogen, argon, carbon dioxide, or nitrous oxide. The filling of these high pressure liquid cylinders must be done by product weight. This will allow enough gas space above the liquid to keep the cylinder from becoming liquid full if its pressure rises to the relief valve setting. The filling weight table (pgs 41 & 42) indicates the correct product weight for the various relief valve settings. The standard relief valve setting is 350 psig (24.1 bar). The filling procedure will show the proper way to use the filling weight table.

The high pressure liquid cylinder is equipped with a liquid and vent valve that are used during the filling procedure. The liquid valve is equipped with a dip tube that extends into the inner vessel of the cylinder and reaches to the bottom. The vent valve has a dip tube attached to it that also extends into the inner vessel of the cylinder. This vent tube is designed to spray the liquid into the top of the vessel so that pump filling through the vent valve will keep head pressure down in the cylinder.

Filling can be accomplished by either pressure transfer or pump fill. The following procedure should be used for pressure transfer fillings, refer to the illustration on page 37:

1. Sample the residual gas that is in the cylinder. Purge the cylinder (refer to the purging procedure, page 58) if necessary to insure the proper purity.
2. Place the cylinder on the filling scale. Record the weight. Compare this weight to the registered tare weight on the data plate. The difference is the weight of the residual gas.
3. Connect the transfer hose to the fill valve (Item 127). Record the new weight. The difference between this weight and the initial weight is the weight of the transfer hose.
4. To determine the total filling weight add the tare weight of the cylinder, the hose weight and the proper filling weight from the table (pg 41). The table indicates the product across the top and the relief valve pressure down the side. Connect the two columns to find the proper weight. Example: Dura-Cyl MCR 160 HP for Carbon Dioxide at 350 psi has a product weight of 387 pounds.
5. Open the cylinders vent and liquid valves (Item 127 and 128). Open the transfer line shut-off valve to begin the flow of product.
6. If filling CO₂, adjust the cylinders vent valve to maintain pressure in the cylinder and fill hose. The equipment must maintain pressures above 70 psi (4.8 BAR) during the transfer. Liquid CO₂ will turn into dry ice at lower pressures.
7. When the scale reads the calculated total filling weight, turn off the liquid valve (Item 127) on the cylinder. Close the vent valve. It is important to maintain pressure above 70 psi (4.8 bar) if filling CO₂ or N₂O. Do not allow the cylinder to vent down after filling.
8. Close the transfer line shut-off valve and relieve the pressure in the transfer line. Remove the transfer line. Remove the cylinder from the scale.

Operating Pressure

The liquid cylinder will automatically maintain a normal operating pressure between the pressure building portion of the regulator (300 psi- 20.7 bar) and the economizer portion of the regulator (325 psi- 22.4 bar). The operating pressure can be set up or down by simply adjusting the regulator while watching the pressure gauge. The adjustment range of the regulators is between 150 and 350 psi (10.6 & 24.1 bar).

The gas delivery pressure should not be confused with the vessel operating pressure. The delivery pressure should be adjusted with a separate regulator that is attached to the gas withdrawal fitting (Item 141).

Liquid CO₂ Withdrawal

Liquid can be withdrawn from these liquid cylinders in the same manner that was described in section 8.0 Cryo-Cyl LP, however the transfer of liquid carbon dioxide is slightly different and should follow this procedure:

1. Connect the transfer hose to the liquid valve fitting (Item 127) of the high pressure liquid cylinder.
2. Connect the other end of the hose to the receiving equipment.
3. Open the pressure building valve (Item 126) and wait for the pressure gauge (Item 120) to reach the operating pressure (300 psi- 20.7 bar).
4. Refer to the receiving equipment manual for procedures to open the fill valve and vent valve of the receiving equipment.
5. Open the liquid valve on the liquid cylinder. This valve can be adjusted to obtain the proper liquid flow rate and delivery pressures.
6. Adjust the receiving equipment vent valve and the fill valve to maintain pressure in the fill hose. The equipment and the hose must maintain pressures above 70 psi (4.8 bar) during the transfer. Liquid CO₂ will turn into dry ice at lower pressures.
7. When the transfer is complete close the receiving equipment's valve. Close the liquid valve on the cylinder and relieve pressure from the hose.
8. Disconnect or remove the hose from the receiving equipment.

CAUTION: The liquid and vent valves on high pressure liquid cylinders should always be kept closed to protect the inner vessel and plumbing from being contaminated.

Gas Withdrawal

The high pressure liquid cylinder will deliver gas at various flow rates and temperatures (shown in Figures J1 & K – page 13) for different applications. The flow rate is controlled by the equipment that is being supplied gas by the liquid cylinder. The continuous flow rate (shown in specification on page 14-16) indicates the flow rate that will normally provide gas at a reasonable temperature and should not be exceeded. Higher flow rates may provide very cold gas that could damage the equipment attached to them.

To supply gaseous product follow this step by step procedure:

1. Connect the proper regulator to the liquid cylinder's gas use outlet (Item 141).
2. Connect the proper hose between the liquid cylinder gas use regulator and the receiving equipment.
3. Open the pressure building valve (Item 126).
4. Allow pressure (refer to gauge Item 120) to build to the operating pressure (300 psi- 20.7 bar).
5. Open the gas use valve (Item 125).
6. Adjust the gas use regulator for the proper delivery pressure.
7. When the gas delivery is completed, close all liquid cylinder valves.

CAUTION: The liquid and vent valves on an empty liquid cylinder should always be kept closed to protect the inner vessel and plumbing from being contaminated.

Service and Maintenance

Refer to section 15 and 16 of this manual to trouble shoot problems and service these liquid cylinders.

STANDARD FILLING WEIGHT TABLE											
RELIEF VALVE Setting (PSIG)	ARGON		NITROGEN		OXYGEN		CO ₂		N ₂ O		
	LBS	SCF	LBS	SCF	LBS	SCF	LBS	SCF	LBS	SCF	
DURA-CYL MCR 160 HP (350 psig max. RV) Gross Cap = 176 Liters											
0 to 45	514	4971	294	4058	418	5048	-	-	-	-	
46 to 75	503	4865	286	3948	406	4903	-	-	-	-	
76 to 105	491	4748	278	3837	398	4770	418	3654	402	3502	
106 to 170	472	4565	271	3741	387	4673	406	3549	391	3406	
171 to 230	460	4448	267	3685	379	4577	402	3514	383	3336	
231 to 295	445	4304	263	3630	371	4480	394	3444	375	3267	
**296 to 350	437	4226	251	3465	360	4347	387	3383	367	3197	
DURA-CYL MCR 180 HP (350 psig max. RV) Gross Cap = 196 Liter											
0 to 45	573	5541	327	4514	465	5615	-	-	-	-	
46 to 75	560	5416	319	4403	452	5458	-	-	-	-	
76 to 105	547	5290	310	4278	444	5362	465	4065	448	3903	
106 to 170	526	5087	301	4155	431	5205	452	3951	435	3789	
171 to 230	513	4961	297	4099	422	5096	448	3916	426	3711	
231 to 295	495	4787	293	4042	413	4987	439	3837	418	3641	
**296 to 360	487	4710	280	3865	401	4842	431	3767	409	3563	
DURA-CYL MCR 200 HP (350 psig max. RV) Gross Cap = 209 Liters											
0 to 45	611	5909	349	47817	496	5990	-	-	-	-	
46 to 75	597	5774	340	4693	482	5821	-	-	-	-	
76 to 105	583	5638	331	4569	473	5712	496	4336	478	4164	
106 to 170	560	5415	321	4431	459	5543	482	4213	464	4042	
171 to 230	547	5290	317	4376	450	5434	478	4178	455	3964	
231 to 295	528	5106	312	4307	441	5326	468	4091	446	3885	
**296 to 360	519	5019	298	4072	427	5156	459	4012	436	3798	
DURA-CYL MCR 230 HP (350 psig max. RV) Gross Cap = 240 Liters											
0 to 45	702	6789	401	5535	570	6883	-	-	-	-	
46 to 75	686	6634	390	5383	554	6690	-	-	-	-	
76 to 105	670	6480	380	5245	543	6557	570	4982	549	4782	
106 to 170	644	6228	369	5093	528	6376	554	4843	533	4643	
171 to 230	628	6073	364	5024	517	6243	549	4799	522	4547	
231 to 295	607	5870	359	4955	506	6110	538	4703	512	4460	
**296 to 350	596	5764	343	4734	491	5929	528	4615	501	4364	
DURA-CYL MCR 265 HP (350 psig max. RV) Gross Cap = 276 Liters											
0 to 45	807	7463	461	6363	655	7910	-	-	-	-	
46 to 75	789	7630	449	6198	637	7692	-	-	-	-	
76 to 105	771	7456	437	6032	625	7548	655	5725	631	5497	
106 to 170	740	7157	425	5866	607	7330	637	5568	613	5340	
171 to 230	722	6982	418	5769	595	7185	631	5516	601	5235	
231 to 295	698	6750	412	5687	582	7028	619	5411	588	5122	
**296 to 350	686	6634	394	5438	564	6811	607	5306	576	5018	

Note: Filling weights are shown as the maximum weight allowed by code. Their related volumes may vary with product density.

** Normal Factory Setting

METRIC FILLING WEIGHT TABLE										
RELIEF VALVE Setting (BAR)	ARGON		NITROGEN		OXYGEN		CO ₂		N ₂ O	
	KG	NM ³	KG	NM ³	KG	NM ³	KG	NM ³	KG	SCF
DURA-CYL MCR 160 HP (24 bar max. RV) Gross Cap = 176 Liters										
0 to 3.1	233	130	133	106	190	133	-	-	-	-
3.2 to 5.2	228	128	130	104	184	129	-	-	-	-
5.3 to 7.2	222	124	126	101	180	126	190	96	182	92
7.3 to 11.7	214	120	123	98	176	123	184	93	177	89
11.8 to 15.9	209	117	121	97	172	120	182	92	174	88
16.0 to 20.3	202	113	119	95	168	117	179	90	170	86
**20.4 to 24.8	198	111	114	91	163	114	176	89	166	84
DURA-CYL MCR 180 HP (24 bar max. RV) Gross Cap = 196 Liter										
0 to 3.1	260	146	148	118	211	148	-	-	-	-
3.2 to 5.2	254	142	145	116	205	143	-	-	-	-
5.3 to 7.2	248	139	141	113	201	141	211	107	203	102
7.3 to 11.7	239	134	137	109	195	136	205	104	197	99
11.8 to 15.9	233	130	135	108	191	134	203	103	193	97
16.0 to 20.3	224	125	133	106	187	131	199	101	190	96
**20.4 to 24.8	221	124	127	101	182	127	195	99	185	93
DURA-CYL MCR 200 HP (24 bar max. RV) Gross Cap = 209 Liters										
0 to 3.1	277	155	158	126	225	157	-	-	-	-
3.2 to 5.2	271	152	154	123	219	153	-	-	-	-
5.3 to 7.2	264	148	150	120	215	150	225	114	217	109
7.3 to 11.7	254	142	146	117	208	145	219	111	210	106
11.8 to 15.9	248	139	144	115	204	143	217	110	206	104
16.0 to 20.3	239	134	141	113	200	140	212	107	202	102
**20.4 to 24.8	235	132	135	108	194	136	208	105	198	100
DURA-CYL MCR 230 HP (24 bar max. RV) Gross Cap = 240 Liters										
0 to 3.1	318	178	182	145	258	180	-	-	-	-
3.2 to 5.2	311	174	177	141	251	176	-	-	-	-
5.3 to 7.2	304	170	172	137	246	172	258	130	249	126
7.3 to 11.7	292	164	167	133	239	167	251	127	242	122
11.8 to 15.9	285	160	165	132	234	164	249	126	237	120
16.0 to 20.3	275	154	163	130	229	160	244	123	232	117
**20.4 to 24.1	270	151	156	125	223	156	239	121	227	115
DURA-CYL MCR 265 HP (24 bar max. RV) Gross Cap = 276 Liters										
0 to 3.1	366	205	209	167	297	208	-	-	-	-
3.2 to 5.2	358	201	204	163	289	202	-	-	-	-
5.3 to 7.2	350	196	198	158	283	198	297	150	286	144
7.3 to 11.7	336	188	193	154	275	192	289	146	278	140
11.8 to 15.9	327	183	190	152	270	189	286	145	273	138
16.0 to 20.3	317	178	187	149	264	185	281	142	267	135
**20.4 to 24.1	311	174	179	143	256	179	275	139	261	132

Note: Filling weights are shown as the maximum weight allowed by code. Their related volumes may vary with product density.

** Normal Factory Setting

12

OPERATION OF DURA-CYL 160 / 180 / 200 / 230 / 265 HP

General

This section of the manual deals with the Dura-Cyl 160 HP, 180 HP, 200 HP, 230 HP, and 265 HP. They will be referred to in this section as high pressure liquid cylinders. These high pressure liquid cylinder models are functionally the same and only vary in capacity. They are designed to transport, store and deliver liquid oxygen, nitrogen, argon, carbon dioxide, or nitrous oxide as a cryogenic liquid or gas. They can be used to transport liquid carbon dioxide or nitrous oxide with the exemption Chart has received from the Department of

Transportation (Transport Canada). The common applications for these high pressure liquid cylinders are to provide gas at pressures up to 350 psi (24.1 BAR) or deliver liquid CO₂. The high pressure liquid cylinder will build and maintain pressure with a pressure control manifold. The pressure building portion of the regulator has a setting of 300 psi (20.7 bar). If the pressure exceeds 325 psi (22.4) the economizer portion of the regulator will supply gas from the tank vapor space to the receiving equipment which will reduce the cylinder pressure. A continuous gas flow can be automatically provided from these cylinders.

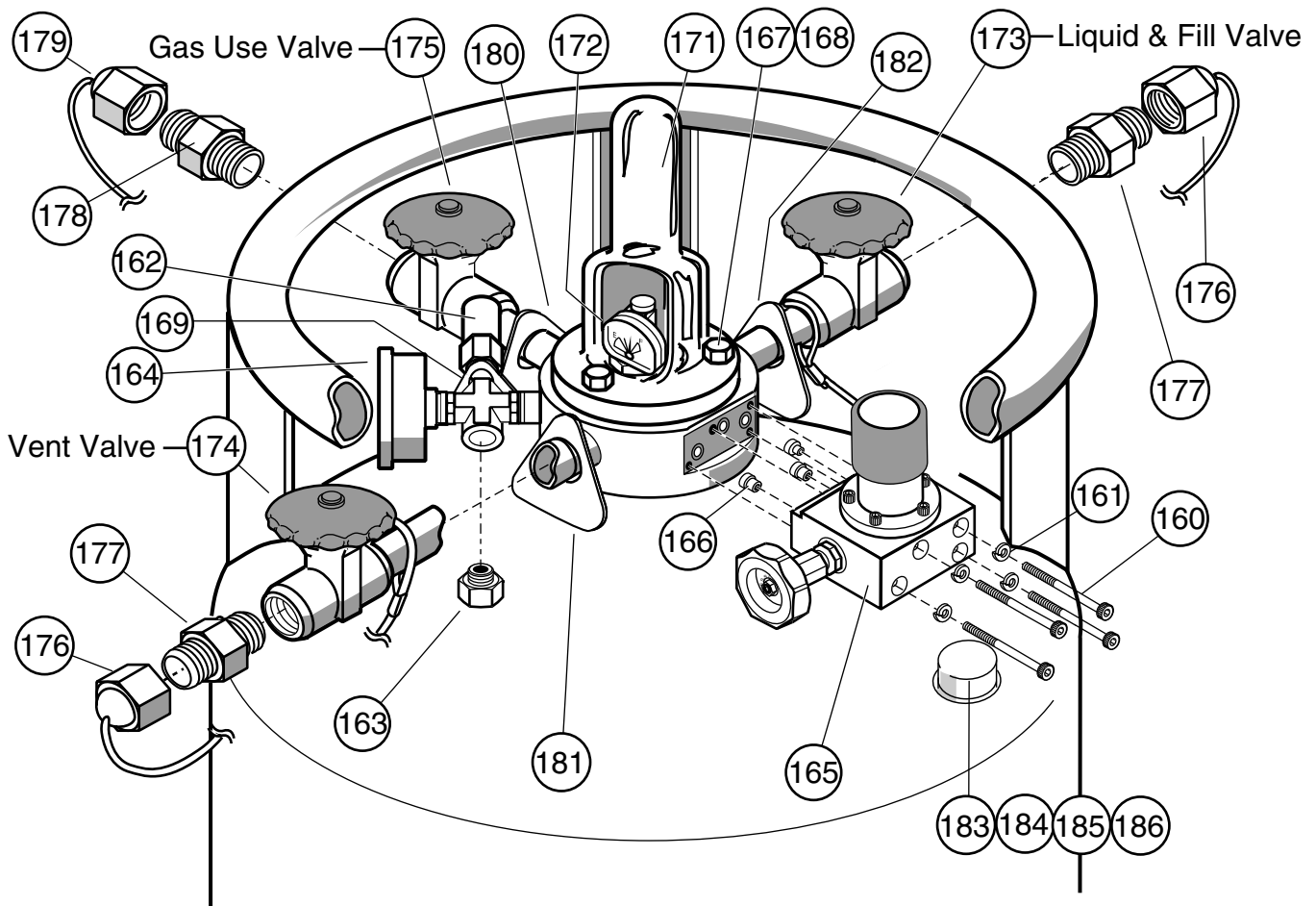

Item	Part No.	Qty.	Spares *	Description
160	11534542	4	4	Bolt SS # 10-32 x 2.5"
161	2911071	4	4	Washer Split Lock # 10 SS
162	11884788	1	1	Pressure Relief Valve -1/4" MPT (350 psi/24.1 BAR) O ₂ ,N ₂ Ar
163	1911632	1	1	Rupture Disc – 1/4" MPT (600 psi/ 41.4 BAR)
164	2010064	1	1	Pressure Gauge – 1/4" CBM (600 psi/ 41.4 BAR)
165	11077142	1	1	LCCM Regulator – 300 psi set pressure
166	10951539	1	1	Knuckle Seal Kit
167	2910601	3		Lockwasher – 1/4" (SS)
168	2910501	3		Screw – 1/4-20 X 5/8" LG (SS)
169	12967551	1		Metal Tag – Relief Valve
171	10534567	1	1	Sight Gauge Protector (Orange)
172	—	1		Liquid Level Indicator (See Page 63)
173	11906043	1		Globe Valve – 3/8 NPT (Liquid Fill) (Blue)
174	11905956	1		Globe Valve – 3/8 NPT (Vent) (Silver)
175	11905964	1		Globe Valve – 3/8 NPT (Gas Use) (Green)
176	4016639	2		Dust Cap – 1/2" ODT (Argon or Nitrogen)
176	4016649	2		Dust Cap – 5/8"ODT (Oxygen)
177	1110072	2	1	Male Connector – 1/2" ODT X 3/8" MPT (Argon or Nitrogen)
177	1110112	2	1	Male Connector – 5/8" ODT X 3/8" NPT (Oxygen)
178	4010022	1	1	Gas Outlet – 3/8" MPT (Argon or Nitrogen)
178	4010012	1	1	Gas Outlet – 3/8" MPT (Oxygen)
179	4010629	1		Dust Cap (Argon or Nitrogen)(optional)
179	4010512	1		Dust Cap (Oxygen)(optional)
180	3811599	1		Metal Tag (Gas Use)
181	3811609	1		Metal Tag (Vent)
182	3811589	1		Metal Tag (Liquid)
183	11732629	1		Pump-Out Body
184	11732637	1		Pump-Out Plug
185	2300059	2		O-ring, Pump-Out Plug
186	3911217	1		Dust Cap, Pump-Out

* Recommended spare parts.

Filling Procedures

The high pressure liquid cylinder is regulated by the DOT/ Transportation Canada for transporting liquid oxygen, nitrogen, argon, carbon dioxide, or nitrous oxide. The filling of these high pressure liquid cylinders must be done by product weight. This will allow enough gas space above the liquid to keep the cylinder from becoming liquid full if its pressure rises to the relief valve setting. The filling weight table (pgs 47 & 48) indicates the correct product weight for the various relief valve settings. The standard relief valve setting is 350 psig (24.1 bar). The filling procedure will show the proper way to use the filling weight table.

The high pressure liquid cylinder is equipped with a liquid and vent valve that are used during the filling procedure. The liquid valve is equipped with a dip tube that extends into the inner vessel of the cylinder and reaches to the bottom. The vent valve has a dip tube attached to it that also extends into the inner vessel of the cylinder. This vent tube is designed to spray the liquid into the top of the vessel so that pump filling through the vent valve will keep head pressure down in the cylinder.

Filling can be accomplished by either pressure transfer or pump fill. The following procedure should be used for pressure transfer fillings, refer to the illustration on page 43:

1. Sample the residual gas that is in the cylinder. Purge the cylinder (refer to the purging procedure, page 58) if necessary to insure the proper purity.
2. Place the cylinder on the filling scale. Record the weight. Compare this weight to the registered tare weight on the data plate. The difference is the weight of the residual gas.
3. Connect the transfer hose to the fill valve (Item 173). Record the new weight. The difference between this weight and the initial weight is the weight of the transfer hose.
4. To determine the total filling weight add the tare weight of the cylinder, the hose weight and the proper filling weight from the table (pg 47). The table indicates the product across the top and the relief valve pressure down the side. Connect the two columns to find the proper weight. Example: Dura-Cyl 160 HP for Carbon Dioxide at 350 psi (24.1 bar) has a product weight of 387 pounds.
5. Open the cylinders vent and liquid valves (Item 173). Open the transfer line shut-off valve to begin the flow of product.
6. If filling CO₂, adjust the cylinders vent valve to maintain pressure in the cylinder and fill hose. The equipment must maintain pressures above 70 psi (4.8 BAR) during the transfer. Liquid CO₂ will turn into dry ice at lower pressures.
7. When the scale reads the calculated total filling weight, turn off the liquid valve (Item 173) on the cylinder. Close the vent valve. It is important to maintain pressure above 70 psi (4.8 bar) if filling CO₂ or N₂O. Do not allow the cylinder to vent down after filling.
8. Close the transfer line shut-off valve and relieve the pressure in the transfer line. Remove the transfer line. Remove the cylinder from the scale.

Operating Pressure

The liquid cylinder will automatically maintain a normal operating pressure between the pressure building portion of the regulator (300 psi–20.7 bar) and the economizer portion of the regulator (325 psi–22.4 bar). The operating pressure can be set up or down by simply adjusting the regulator while watching the pressure gauge. The adjustment range of the regulators is between 80 and 320 psi (5.5 and 24.1 bar).

The gas delivery pressure should not be confused with the vessel operating pressure. The delivery pressure should be adjusted with a separate regulator that is attached to the gas withdrawal fitting (Item 178).

Liquid CO₂ Withdrawal

Liquid can be withdrawn from these liquid cylinders in the same manner that was described in section 8.0 Cryo-Cyl LP, however the transfer of liquid carbon dioxide is slightly different and should follow this procedure:

1. Connect the transfer hose to the liquid valve fitting (Item 177) of the high pressure liquid cylinder.
2. Connect the other end of the hose to the receiving equipment.
3. Open the pressure building valve (Item A) and wait for the pressure gauge (Item 164) to reach the operating pressure (300 psi- 20.7 bar).
4. Refer to the receiving equipment manual for procedures to open the fill valve and vent valve of the receiving equipment.
5. Open the liquid valve on the liquid cylinder. This valve can be adjusted to obtain the proper liquid flow rate and delivery pressures.
6. Adjust the receiving equipment vent valve and the fill valve to maintain pressure in the fill hose. The equipment and the hose must maintain pressures above 70 psi (4.8 bar) during the transfer. Liquid CO₂ will turn into dry ice at lower pressures.
7. When the transfer is complete close the receiving equipment's valve. Close the liquid valve on the cylinder and relieve pressure from the hose.
8. Disconnect or remove the hose from the receiving equipment.

CAUTION: The liquid and vent valves on high pressure liquid cylinders should always be kept closed to protect the inner vessel and plumbing from being contaminated.

Gas Withdrawal

The high pressure liquid cylinder will deliver gas at various flow rates and temperatures (shown in Figures J1 & K – page 13) for different applications. The flow rate is controlled by the equipment that is being supplied gas by the liquid cylinder. The continuous flow rate (shown in specification on page 14-16) indicates the flow rate that will normally provide gas at a reasonable temperature and should not be exceeded. Higher flow rates may provide very cold gas that could damage the equipment attached to them.

To supply gaseous product follow this step by step procedure:

1. Connect the proper final line regulator to the liquid cylinder's gas use outlet (Item 178).
2. Connect the proper hose between the liquid cylinder gas use regulator and the receiving equipment.
3. Open the pressure building valve (Item A).
4. Allow pressure (refer to gauge Item 164) to build to the operating pressure (300 psi- 20.7 bar).
5. Open the gas use valve (Item 175).
6. Adjust the gas use regulator for the proper delivery pressure.
7. When the gas delivery is completed, close all liquid cylinder valves.

CAUTION: The liquid and vent valves on an empty liquid cylinder should always be kept closed to protect the inner vessel and plumbing from being contaminated.

Service and Maintenance

Refer to sections 15 and 16 of this manual to trouble shoot problems and service these liquid cylinders.

12

OPERATION OF DURA-CYL 160 / 180 / 200 / 230 / 265 HP

STANDARD FILLING WEIGHT TABLE										
RELIEF VALVE Setting (PSIG)	ARGON		NITROGEN		OXYGEN		CO ₂		N ₂ O	
	LBS	SCF	LBS	SCF	LBS	SCF	LBS	SCF	LBS	SCF
DURA-CYL 160 HP (350 psig max. RV) Gross Cap = 176 Liters										
0 to 45	514	4971	294	4058	418	5048	-	-	-	-
46 to 75	503	4865	286	3948	406	4903	-	-	-	-
76 to 105	491	4748	278	3837	398	4770	418	3654	402	3502
106 to 170	472	4565	271	3741	387	4673	406	3549	391	3406
171 to 230	460	4448	267	3685	379	4577	402	3514	383	3336
231 to 295	445	4304	263	3630	371	4480	394	3444	375	3267
**296 to 350	437	4226	251	3465	360	4347	387	3383	367	3197
DURA-CYL 180 HP (350 psig max. RV) Gross Cap = 196 Liter										
0 to 45	573	5541	327	4514	465	5615	-	-	-	-
46 to 75	560	5416	319	4403	452	5458	-	-	-	-
76 to 105	547	5290	310	4278	444	5362	465	4065	448	3903
106 to 170	526	5087	301	4155	431	5205	452	3951	435	3789
171 to 230	513	4961	297	4099	422	5096	448	3916	426	3711
231 to 295	495	4787	293	4042	413	4987	439	3837	418	3641
**296 to 360	487	4710	280	3865	401	4842	431	3767	409	3563
DURA-CYL 200 HP (350 psig max. RV) Gross Cap = 209 Liters										
0 to 45	611	5909	349	47817	496	5990	-	-	-	-
46 to 75	597	5774	340	4693	482	5821	-	-	-	-
76 to 105	583	5638	331	4569	473	5712	496	4336	478	4164
106 to 170	560	5415	321	4431	459	5543	482	4213	464	4042
171 to 230	547	5290	317	4376	450	5434	478	4178	455	3964
231 to 295	528	5106	312	4307	441	5326	468	4091	446	3885
**296 to 360	519	5019	298	4072	427	5156	459	4012	436	3798
DURA-CYL 230 HP (350 psig max. RV) Gross Cap = 240 Liters										
0 to 45	702	6789	401	5535	570	6883	-	-	-	-
46 to 75	686	6634	390	5383	554	6690	-	-	-	-
76 to 105	670	6480	380	5245	543	6557	570	4982	549	4782
106 to 170	644	6228	369	5093	528	6376	554	4843	533	4643
171 to 230	628	6073	364	5024	517	6243	549	4799	522	4547
231 to 295	607	5870	359	4955	506	6110	538	4703	512	4460
**296 to 350	596	5764	343	4734	491	5929	528	4615	501	4364
DURA-CYL 265 HP (350 psig max. RV) Gross Cap = 276 Liters										
0 to 45	807	7463	461	6363	655	7910	-	-	-	-
46 to 75	789	7630	449	6198	637	7692	-	-	-	-
76 to 105	771	7456	437	6032	625	7548	655	5725	631	5497
106 to 170	740	7157	425	5866	607	7330	637	5568	613	5340
171 to 230	722	6982	418	5769	595	7185	631	5516	601	5235
231 to 295	698	6750	412	5687	582	7028	619	5411	588	5122
**296 to 350	686	6634	394	5438	564	6811	607	5306	576	5018

Note: Filling weights are shown as the maximum weight allowed by code. Their related volumes may vary with product density.

** Normal Factory Setting

METRIC FILLING WEIGHT TABLE										
RELIEF VALVE Setting (BAR)	ARGON		NITROGEN		OXYGEN		CO ₂		N ₂ O	
	KG	NM ³	KG	NM ³	KG	NM ³	KG	NM ³	KG	SCF
DURA-CYL 160 HP (24 bar max. RV) Gross Cap = 176 Liters										
0 to 3.1	233	130	133	106	190	133	-	-	-	-
3.2 to 5.2	228	128	130	104	184	129	-	-	-	-
5.3 to 7.2	222	124	126	101	180	126	190	96	182	92
7.3 to 11.7	214	120	123	98	176	123	184	93	177	89
11.8 to 15.9	209	117	121	97	172	120	182	92	174	88
16.0 to 20.3	202	113	119	95	168	117	179	90	170	86
**20.4 to 24.8	198	111	114	91	163	114	176	89	166	84
DURA-CYL 180 HP (24 bar max. RV) Gross Cap = 196 Liter										
0 to 3.1	260	146	148	118	211	148	-	-	-	-
3.2 to 5.2	254	142	145	116	205	143	-	-	-	-
5.3 to 7.2	248	139	141	113	201	141	211	107	203	102
7.3 to 11.7	239	134	137	109	195	136	205	104	197	99
11.8 to 15.9	233	130	135	108	191	134	203	103	193	97
16.0 to 20.3	224	125	133	106	187	131	199	101	190	96
**20.4 to 24.8	221	124	127	101	182	127	195	99	185	93
DURA-CYL 200 HP (24 bar max. RV) Gross Cap = 209 Liters										
0 to 3.1	277	155	158	126	225	157	-	-	-	-
3.2 to 5.2	271	152	154	123	219	153	-	-	-	-
5.3 to 7.2	264	148	150	120	215	150	225	114	217	109
7.3 to 11.7	254	142	146	117	208	145	219	111	210	106
11.8 to 15.9	248	139	144	115	204	143	217	110	206	104
16.0 to 20.3	239	134	141	113	200	140	212	107	202	102
**20.4 to 24.8	235	132	135	108	194	136	208	105	198	100
DURA-CYL 230 HP (24 bar max. RV) Gross Cap = 240 Liters										
0 to 3.1	318	178	182	145	258	180	-	-	-	-
3.2 to 5.2	311	174	177	141	251	176	-	-	-	-
5.3 to 7.2	304	170	172	137	246	172	258	130	249	126
7.3 to 11.7	292	164	167	133	239	167	251	127	242	122
11.8 to 15.9	285	160	165	132	234	164	249	126	237	120
16.0 to 20.3	275	154	163	130	229	160	244	123	232	117
**20.4 to 24.1	270	151	156	125	223	156	239	121	227	115
DURA-CYL 265 HP (24 bar max. RV) Gross Cap = 276 Liters										
0 to 3.1	366	205	209	167	297	208	-	-	-	-
3.2 to 5.2	358	201	204	163	289	202	-	-	-	-
5.3 to 7.2	350	196	198	158	283	198	297	150	286	144
7.3 to 11.7	336	188	193	154	275	192	289	146	278	140
11.8 to 15.9	327	183	190	152	270	189	286	145	273	138
16.0 to 20.3	317	178	187	149	264	185	281	142	267	135
**20.4 to 24.1	311	174	179	143	256	179	275	139	261	132

Note: Filling weights are shown as the maximum weight allowed by code. Their related volumes may vary with product density.

** Normal Factory Setting

13 OPERATION OF CRYO-CYL 80 HP

General

This section of the manual deals with the Cryo-Cyl 80HP liquid cylinder. The Cryo-Cyl 80 HP is designed to transport and store liquid oxygen, nitrogen, argon, carbon dioxide or nitrous oxide and provide it as a gas. It is a smaller version of the liquid cylinder that is designed to supply gas at lower flow rates than the regular liquid cylinders. The Cryo-Cyl 80 HP can provide gas at pressures up to 350 psi (24.1 BAR). The Cryo-Cyl 80 HP will build and maintain an operating pressure at the pressure building regulator setting of 125 psi (8.6 BAR).

If the operating pressure exceeds 125 psi (8.6 BAR), the pressure will be lowered as the gas is delivered. A separate economizer regulator is not provided on the Cryo-Cyl 80 HP. A continuous gas flow can be automatically provided from this cylinder.

Liquid can be withdrawn from the Cryo-Cyl 80 HP in the same manner that was described in section 8.0 Cryo-Cyl LP.

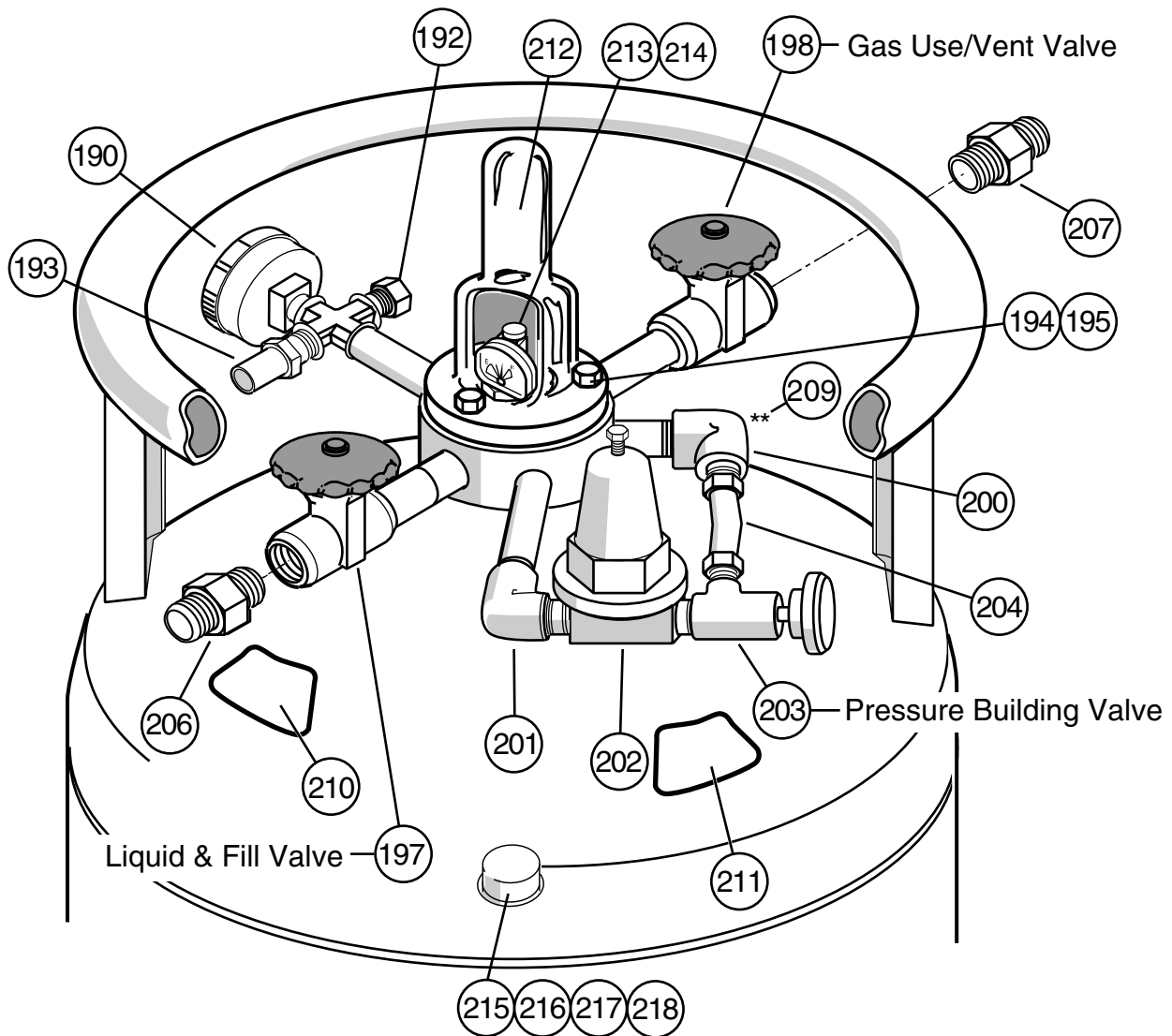

OPERATION OF CRYO-CYL 80 HP 13

Item	Part No.	Qty.	Spares *	Description
190	2010064	1	1	Pressure Gauge (0-600 psig/ 41.4 BAR)
192	1911632	1	1	Safety Rupture Disc (600 psi/ 41.4 BAR)
193	11884788	1	1	Pressure Relief Valve – 1/4" MPT (350 psi/24.1 BAR)
194	2910501	3		Bolt - 1/4 - 20 x 5/8" Lg. (SS)
195	2910601	3		Lockwasher - 1/4" (SS)
197	11906043	1		Globe Valve – 3/8" FPT (Liquid Fill)(Blue)
198	11905956	1		Globe Valve – 3/8" FPT (Gas Use/Vent)(Silver)
200	13670935	1		Elbow – 1/4" ODT X 1/4" FPT
201	1210462	1		Street Elbow – 1/4" NPT
202	2110032	1	1 for 4	Pressure Building Regulator - 125 psi set pressure
203	1711862	1		Valve – 1/4" ODT X 1/4" MPT (Pressure Builder)
204	6910693	1		Copper Tubing – 1/4" ODT
206	1110072	1	1	Male Connector – 1/2" ODT X 3/8" MPT (Ar or N ₂)
206	1110112	1	1	Male Connector – 5/8" ODT X 3/8" MPT (Oxygen)
207	4010022	1	1	Vent/Gas Outlet – 3/8" MPT X CGA-580 (Ar or N ₂)
207	4010012	1	1	Vent/Gas Outlet – 3/8" MPT X CGA-540 (Oxygen)
209**	10659298	1		Decal (Vent/ Gas Use)
210	3830599	1		Decal (Liquid/ Fill)
211	3830589	1		Decal (Pressure Builder)
212	10534567	1		Sight Gauge Protector
213	–	1		Sight Gauge Assembly (see pg 63)
214	2300094	1		O-ring (Silicon) Liquid Level Gauge
215	11732629	1		Pump-Out Body
216	11732637	1		Pump-Out Plug
217	2300059	2		O-ring, Pump-Out Plug
218	3911217	1		Dust Cap, Pump-Out

* Recommended spare parts

** Not Shown

13 OPERATION OF CRYO-CYL 80 HP

Filling Procedures

The Cryo-Cyl 80 HP is regulated by the Department of Transportation (US DOT) for transporting liquid oxygen, nitrogen, argon, CO₂ or N₂O. The filling of these liquid cylinders must be done by product weight. This will allow enough gas space above the liquid to keep the liquid cylinder from becoming liquid full if its pressure rises to the relief valve setting. The filling weight table (pg 52) indicates the correct product weight for the various relief valve settings. The standard relief valve setting is 350 psig (24.1 BAR). The filling procedure will show the proper way to use the filling weight table.

The liquid cylinder is equipped with a liquid and vent valve that are used during the filling procedure. The liquid valve is equipped with a dip tube that extends into the inner vessel of the cylinder and reaches to the bottom. The vent valve has a dip tube attached to it that also extends into the inner vessel near the top of the cylinder.

Filling can be accomplished by pressure transfer. The following procedure should be used, refer to the illustration on page 49:

1. Sample the residual gas that is in the cylinder. Purge the cylinder (refer to the purging procedure, page 58) if necessary to insure the proper purity.
2. Place the cylinder on the filling scale. Record the weight. Compare this weight to the registered tare weight on the data plate. The difference is the weight of the residual gas.
3. Connect the transfer hose to the fill fitting (Item 206). Record the new weight. The difference between this weight and the initial weight is the weight of the transfer hose.
4. To determine the total filling weight add the tare weight of the cylinder, the hose weight and the proper filling weight from the table (pg 52). The table indicates the product across the top and the relief valve pressure down the side. Connect the two columns to find the proper weight. Example: Oxygen at 350 psi has a product weight of 173 pounds.
5. Open the cylinders vent (Item 198) and liquid valves (Item 197). Open the transfer line shut-off valve to begin the flow of product.

6. When the scale reads the calculated total filling weight turn off the liquid valve (Item 197) on the cylinder. Close the vent valve (Item 198).
7. Close the transfer line shut-off valve and relieve the pressure in the transfer line. Remove the transfer line. Remove the cylinder from the scale.

Operating Pressure

The Cryo-Cyl 80 HP will automatically maintain an operating pressure between the pressure building regulator (125 psi–8.6 BAR) and the relief valve setting (350 psi–24.1 BAR). The lower limit of the operating pressure can be set up or down by adjusting the pressure building regulator. The adjustment range of the regulator is between 75 and 175 psi (5.2 and 12.1 BAR). Refer to section 16 for adjustment procedures.

The gas delivery pressure should not be confused with the vessel operating pressure. The delivery pressure should be adjusted with a separate regulator that is attached to the gas withdrawal fitting (Item 207).

Gas Withdrawal

The Cryo-Cyl 80 HP will deliver gas at various flow rates and temperatures (as shown in Figure J2 – page 13) for different applications. The flow rate is controlled by the equipment that is being supplied gas from the liquid cylinder. The continuous flow rate (as shown in the specification, pages 14-16) indicates the flow rate that will normally provide gas at a reasonable temperature and should not be exceeded. Higher flow rates may provide very cold gas that could damage the equipment that they are attached to.

To supply gaseous product follow this step by step procedure:

1. Connect the proper regulator to the Cryo-Cyl 80 HP gas use outlet (Item 207).
2. Connect the proper hose between the final line regulator and the receiving equipment.
3. Open the pressure building valve (Item 203).
4. Allow pressure (refer to gauge Item 190) to build to the operating pressure (125 psi–8.6 BAR).

OPERATION OF CRYO-CYL 80 HP 13

5. Open the gas use valve (Item 198).
6. Adjust the final line regulator for the proper delivery pressure.
7. When the gas delivery is completed, close all liquid cylinder valves.

CAUTION: The liquid and vent valves on an empty liquid cylinder should always be kept closed to protect the inner vessel and plumbing from being contaminated.

Service and Maintenance

Refer to section 15 and 16 of this manual to trouble shoot problems and service these liquid cylinders.

STANDARD FILLING WEIGHT TABLE

RELIEF VALVE Setting (PSIG)	ARGON		NITROGEN		OXYGEN		CO ₂		N ₂ O	
	LBS	SCF	LBS	SCF	LBS	SCF	LBS	SCF	LBS	SCF
CRYO-CYL 80 HP (350 psig max. RV)										
Gross Cap = 85 Liters										
0 to 45	248	2398	142	1960	201	2427	-	-	-	-
46 to 75	243	2350	138	1904	196	2367	-	-	-	-
76 to 105	237	2292	134	1849	192	2318	201	1756	194	1695
106 to 170	228	2204	130	1794	187	2258	196	1713	188	1643
171 to 230	222	2146	129	1780	183	2210	194	1695	185	1616
231 to 295	215	2079	127	1752	179	2161	190	1660	181	1581
**296 to 360	211	2040	121	1670	173	2089	187	1634	177	1546

METRIC FILLING WEIGHT TABLE

RELIEF VALVE Setting (BAR)	ARGON		NITROGEN		OXYGEN		CO ₂		N ₂ O	
	KG	NM ³	KG	NM ³	KG	NM ³	KG	NM ³	KG	NM ³
CRYO-CYL 80 HP (24.1 bar max. RV)										
Gross Cap = 85 Liters										
0 to 3.1	112	63	64	51	94	66	-	-	-	-
3.2 to 5.1	110	62	63	50	89	62	-	-	-	-
5.2 to 7.2	107	60	61	49	87	61	91	46	88	44
7.3 to 11.7	103	58	59	47	85	59	89	45	85	43
11.8 to 15.9	101	57	58	46	83	58	88	44	84	42
16.0 to 20.3	98	55	58	46	81	57	86	43	82	41
**20.4 to 24.8	96	54	55	44	78	55	85	43	80	40

Note: Filling weights are shown as the maximum weight allowed by code. Their related volumes may vary with product density.

*** Normal Factory Setting*

14 DURA-CYL / CRYO-CYL BASE DESIGN

The Dura-Cyl/Cryo-Cyl Series liquid cylinder has various base designs that help the cylinder stand straight and make handling easier. Refer to the Base Identification table on page 48 to match the Dura-Cyl/Cryo-Cyl Series model with its base design.

Footring Design:

The Dura-Cyl/Cryo-Cyl liquid cylinder has a footring design that employs a Belleville washer to absorb the shock associated with normal handling. It is constructed from stainless steel and welded to the bottom of the cylinder.

Caster Base Design

The Dura-Cyl 230/265 and Cryo-Cyl 230/265 liquid cylinders are offered with a permanently mounted caster base. The casters are either swivel or fixed and may have friction brakes. Refer to the parts list on page 54 for the caster options.

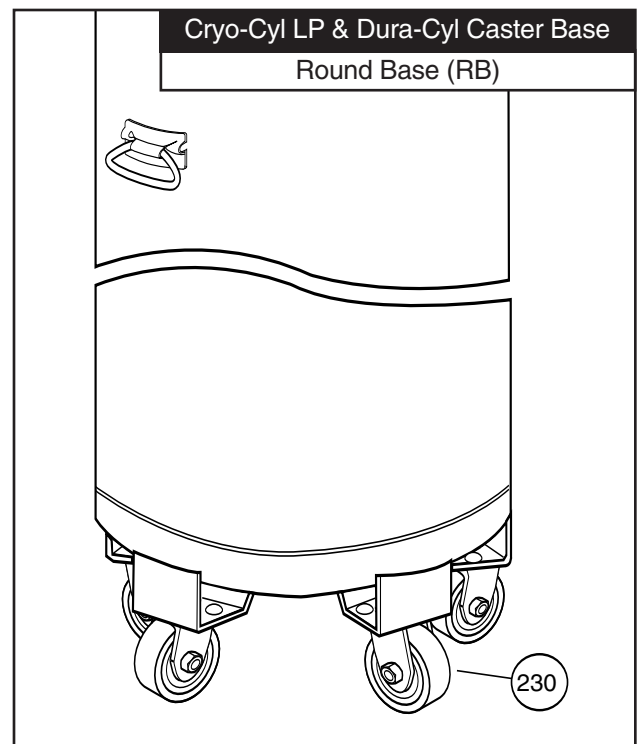
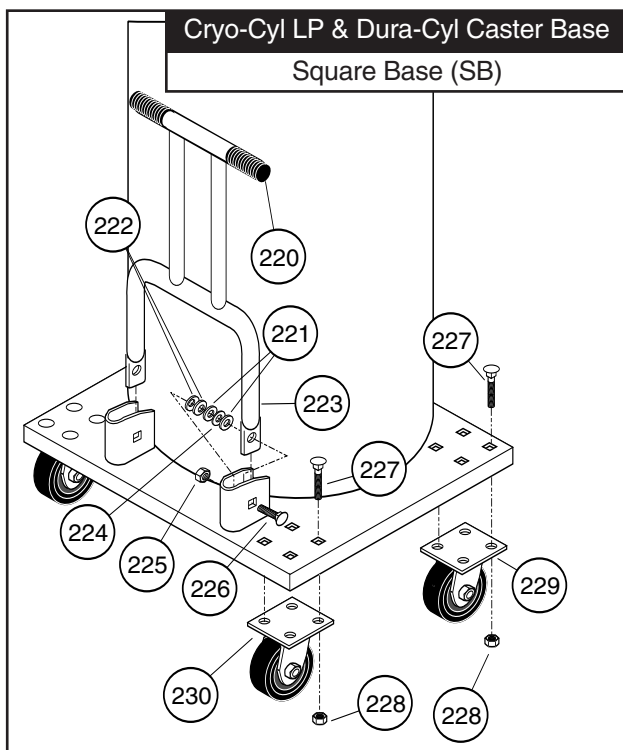
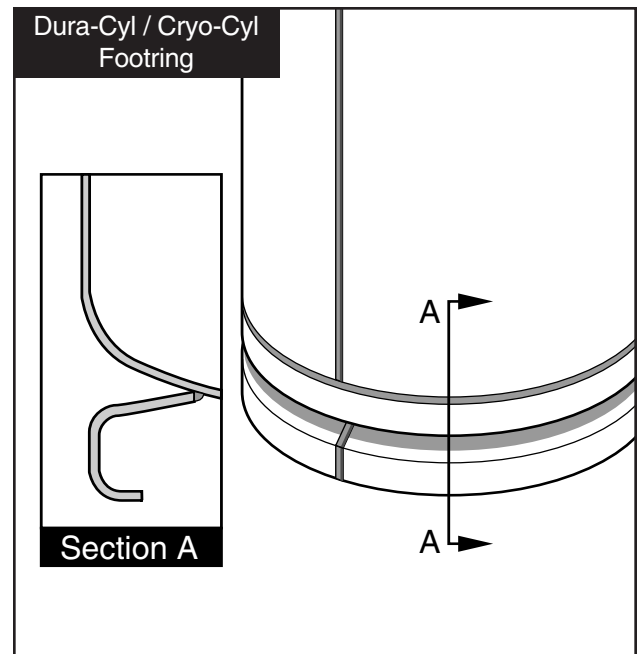

DURA-CYL / CRYO-CYL BASE DESIGN 14

Base Identification Table	CRYO-CYL 80HP	CRYO-CYL 120 LP	CRYO-CYL 180 LP	DURA-CYL 280 LP	DURA-CYL 160 MP	DURA-CYL 160 HP	DURA-CYL 180 MP	DURA-CYL 180 HP	DURA-CYL 200 MP	DURA-CYL 200 HP	DURA-CYL 230 MP	DURA-CYL 230 HP	DURA-CYL 265 MP	DURA-CYL 265 HP	DURA-CYL MCR 160 MP	DURA-CYL MCR 160 HP	DURA-CYL MCR 180 MP	DURA-CYL MCR 180 HP	DURA-CYL MCR 200 MP	DURA-CYL MCR 200 HP	DURA-CYL MCR 230 MP	DURA-CYL MCR 230 HP	DURA-CYL MCR 265 MP	DURA-CYL MCR 265 HP		
Square Base Caster*					X								X	X	X	X										
Round Base Caster*		X			X																		X	X	X	X
Dura Footring	X			X		X	X	X	X	X	X	X					X	X	X	X	X	X				

* non-magnetic casters (optional)

CASTER BASE PARTS IDENTIFICATION

Item	Part No.	Qty.	Spares *	Description
220	4311359	2		Handgrip – 1" (black)
221	2913711	4		Flat Washer (SS)
222	2913731	4		Spring Disk – 3/4" x 382 ID (SS)
223	8500219	1		Handle Assy
224	2913749	2		Washer – 1" OD x 3/8 ID (nylon)
225	2913671	2		Locknut – 3/8" 16 (SS)
226	2913721	2		Carriage Bolt – 3/8" – 16 x 1-1/2" LG
227	2914711	16		Carriage Bolt – 3/8" – 16 x 1-1/4" LG
228	2913671	16		Locknut – 3/8" – 16
** 229	3110501	2		Fixed Caster – 5" (non-magnetic)
** 229	3110699	2		Fixed Caster – 4" (magnetic)
** 230	3110689	2 (1 on RB)		Swivel Caster – 4" (magnetic – w/brake)
** 230	10523260	2 (4 on RB)		Swivel Caster – 4" (magnetic)
** 230	3110491	2 (1 on RB)		Swivel Caster 5" (non-magnetic – with brake)
** 230	3110481	2 (4 on RB)		Swivel Caster – 5" (non-magnetic)

* Recommended spare parts

** 4" Magnetic without brake is standard – 5" Non-Magnetic optional.

15 TROUBLESHOOTING

The troubleshooting section of this manual deals with the normal operating conditions and the problems that may occur with the Dura-Cyl/Cryo-Cyl Series liquid cylinders. The troubleshooting guide assumes that the tank is in its normal operating environment having a cooled down inner vessel and a reasonable vacuum. Before troubleshooting an operational problem, the liquid cylinder should be examined for vacuum.

Loss of Vacuum

The loss of vacuum on a liquid cylinder is usually associated with excessive cylinder frosting or rapid pressure rise. Excessive pressure rise, however, can be normal. A new liquid cylinder or one that has not been used recently is considered to have a warm inner vessel. Warm cylinders will build pressure fast after filling and vent off the excess. A liquid cylinder that has been filled and not used will build pressure and vent the excess off. The higher the pressure was in the storage tank at the time of filling the faster the liquid cylinder will vent off.

Excessive pressure rise can also be an indication of vacuum loss. The Dura-Cyl/Cryo-Cyl Series liquid cylinders are equipped with a pump-out plug that is expelled from the pump-out body if there is a loss of vacuum. This indicates an inner vessel leak. The pump-out body and plug are covered by a black plastic cap to protect them from the environment and tampering. If it is determined that the pump-out plug is properly seated in the pump-out body, but a loss of vacuum is still suspected, an evaporative loss rate test should be performed.

Vented Evaporation Loss Test

The vented evaporation loss test should be used on liquid cylinders that are in nitrogen, oxygen or argon service. It should be done over a period of 3 to 4 days.

1. Fill the container to the half full mark using the same product the container previously contained.
2. Verify that the pressure building, gas use, and liquid withdrawal valves are all closed.
3. Allow container to vent for approximately 24 hours.
4. Weigh the container as accurately as possible.
5. Allow the container to continue venting for an additional 48 hours.
6. Weigh the container as accurately as possible.

7. Calculate the difference between the two weights obtained in steps 3 and 5. A weight loss of more than 16 lbs. (7.3 kg) in 48 hours is considered excessive; contact your local Chart distributor or the factory for appropriate disposition.
8. If the weight loss is not excessive, proceed with pressurized evaporation loss test.

Pressurized Evaporation Loss Test

The pressurized evaporation loss test should be used on liquid cylinders that passed the vented loss test or are in CO₂ or N₂O service. It will take longer than a vented test since the pressure must rise by evaporation only.

1. Pressurize the unit to 50 psig (3.4 BAR) and check for any plumbing leaks.
2. Vent and then fill the unit with its designated service product. Maintain pressure in the liquid cylinder while filling. Do not vent after filling.
3. Verify that all valves are tightly closed.
4. Observe pressure rise to relief valve setting. (This could take up to 6 days for a typical cylinder.)
5. Once the unit is at relief valve pressure, weigh it as accurately as possible.
6. Check weight a second time after 24 hours.
7. Calculate the difference between the two weights obtained in steps 5 and 6. A weight loss of more than 10 lbs. (4.5 kg) in 24 hours is considered excessive; contact your local Chart distributor or the factory for appropriate disposition.
8. If the weight loss is not excessive, the liquid cylinder is considered to have the proper vacuum level.

Follow the troubleshooting guide and the repair procedures found in section 16. If there are any other questions, contact Chart's Technical Service Department at:

1-800-400-4683

1-952-758-4484

Problem	Problem Cause	Corrective Action
Liquid cylinder builds excessive pressure or builds pressure too fast.	Low usage.	If daily gas usage is under 100 SCF (2.8 NM ³), the cylinder will build pressure. In liquid service, the cylinder should be equipped with low pressure relief valve and regulator. Normal pressure rise should not be more than 50 psi (3.4 BAR)per day.
	Cylinder is over filled.	If the cylinder is filled past the vent trycock or past the DOT specified fill weight, the pressure may rise rapidly after a fill.
	Pressure building regulator is set improperly or leaks.	If the pressure builds and stays at a pressure higher than desired, adjust the pressure building regulator to a new setting
		If the pressure builds to the relief valve setting and the P. B. coil near the bottom of the tank is cold or frosted, replace the regulator.
	Vacuum is deteriorating.	This can be accompanied by cold or frost occurring evenly over the cylinder surface. Refer to the troubleshooting section on frost.
Liquid cylinder pressure is too low.	Pressure builder valve is closed.	Open Valve.
	Pressure building regulator is set too low.	Adjust the regulator as described in Section 16, page 60 (For gas service)
	Pressure building regulator is not opening properly.	Bench test the regulator for full flow at the set pressure as described in Section 16, page 62.
	Usage is too high.	Refer to Section 6, pages 14-16 (Specification), for maximum recommended delivery rates; or to Figure H, page 12 for pressure building capacities.
	Cylinder is leaking.	Check for frost on lines or on top of head. Listen for hissing, soap test joints for leaks. Isolate leak and call Chart for repair details.
Frost occurs around the circumference of the shell 4" to 8" (10.2 to 20.4 cm) from the floor.	Cylinder is building pressure with the pressure building circuit.	This is normal if the cylinder pressure is lower than the pressure building regulator setting.
	Frost is residual from last fill or earlier use.	This is normal. A ring of ice or an oval shaped ice ball often remains on the cylinder for days after the last use or fill.
Frost occurs around the circumference of the shell 10" (25.4 cm)from the floor and up. Frost spot spirals up the shell.	Cylinder is vaporizing liquid into gas.	This is normal. The frost should melt within two hours after the gas use stops

Continued on next page

15 TROUBLESHOOTING

Problem	Problem Cause	Corrective Action
Frost occurs on head or knuckle.	Residual frost remains from last fill or recent product use.	This is normal. Ice may remain for days after a fill or heavy use.
	Sight gauge is leaking.	Check for gas escaping from under sight gauge. Refer to Section 16, page 62, for repair.
Frost occurs evenly over the cylinder surface.	The gas withdrawal rate is high. Both the P. B. and gas use vaporizers are frosted.	This is normal.
	Cylinder has lost vacuum.	This is accompanied by high rate of pressure rise or high loss rate. Call Chart for return instructions.
Miscellaneous frost spots on cylinders.	Cylinder may have internal damage.	Call Chart for evaluation or repair/return information.
Delivery gas is too cold.	Delivery rate exceeds recommended delivery.	Refer to Section 6, pages 14-16, for recommended maximum delivery rates.
In liquid delivery, liquid is mixed with high amount of gas.	Cylinder pressure is higher than optimum for liquid withdrawal.	Refer to Section 16, page 61, for instructions on resetting the cylinder pressure for liquid use. Also, use a phase separator on the end of the transfer hose.
In CO ₂ service, cylinder does not deliver product properly.	Possible dry ice blocks have formed in system.	Refer to Section 16, page 60, for reliquefying procedures.

For further information contact Chart's Technical Service Department at (800) 400-4683 or (952) 758-4484.

General

This section contains the information regarding the liquid cylinder care and maintenance. It includes the particular maintenance procedures for changes to the operating pressure, service pressure and liquid service changes. When performing a procedure that is described in this section, refer to the previous sections on operation (Section 8 through 13) for a components item number and location.

Safety

Before implementing any procedure described in this section, it is recommended that section 3.0 "Safety" and Section 18, "Product Safety Bulletins" be read and fully understood.

O₂ Cleaning

Always keep cylinders clean and free from grease and oil. This applies not only to containers used in oxygen service, but also to those used in nitrogen and argon service.

When repairing containers, use only parts which are considered compatible with liquid oxygen and which have been properly cleaned for oxygen service. (Refer to CGA Pamphlet G.4.1 "Equipment Cleaned for Oxygen Service".) Do not use regulators, fittings, or hoses which were previous used in a compressed air service. Use only oxygen compatible sealants or Teflon tape on the threaded fittings. All new joints should be leak tested with an oxygen compatible leak test solution.

CAUTION: Before conducting maintenance or replacing parts on a cylinder, release container pressure in a safe manner. Replacement of certain cylinder parts may also require that the container contents be completely emptied.

Changing Service

The Dura-Cyl/Cryo-Cyl Series liquid cylinders are designed to hold any of the gas products specified. They can easily be modified to work as well with nitrogen as oxygen. The fittings and decals need to be changed and the inner vessel needs to be purged.

If a cylinder is changed from inert (argon or nitrogen) to CO₂ service, the relief valve must be changed to a CO₂ relief valve.

WARNING: Cylinders used in oxygen service must not be changed to CO₂ service.

WARNING: Once a cylinder is used in CO₂ service, it can not be used for other gas products, especially oxygen or nitrous oxide.

WARNING: Whenever converting a Nitrogen or Argon cylinder to Oxygen use, inspect the cylinder to assure cleanliness.

Recommended Inner Vessel Purging (With a Vacuum Pump)

Before any operation that involves pressure or handling of a cryogenic fluid, be sure that all safety precautions are taken.

1. Open the vent to remove any pressure that has built in the inner vessel.
2. Open the pressure building valve to boil away any cryogenic liquid that remains in the vessel.
3. Warm the inner vessel with warm nitrogen gas through the liquid valve. Check the gas temperature as it escapes through the open vent valve. Continue until it is warm.
4. Close the liquid valve, gas use and pressure building valves.
5. Attach a vacuum pump to the vent valve and evacuate the inner vessel to 26 inches of mercury.
6. Break the vacuum to 5 psig (0.3 bar) with high purity gas as required by the service of the container.
7. Repeat steps 6 and 7 twice.
8. Close all valves and remove the vacuum and gas purge lines. The container is now ready for filling.

16 SERVICE AND MAINTENANCE

Fittings And Decals

It is very important that the proper fittings for the specific gas product being transported are installed on the liquid cylinder. The Compressed Gas Association regulates the fitting design so that equipment compatibility is based on gas product. This keeps from having a nitrogen tank being attached to a hospital's oxygen supply. DO NOT use fitting adapters. The proper fittings are shown in the parts lists of section 8 through 13 for the different models of liquid cylinders.

The decals should be placed on the tank as shown in figure Y. The decal's part numbers are shown with the illustration. The sight gauge decal for the Cryo-Cyl LP (shown in Figure DD, page 64) should be located so that the bottom of the decal lines up with the ridge on the sight gauge tube. The Dura-Cyl & Cryo-Cyl 80HP has a unique plastic level gauge (Figure EE, Page 63) that can be snapped off the tank and replaced for each gas product. Pull the plastic level gauge straight to the side to remove it. The new level gauge should be snapped on securely.

ITEM	PART NO.	PART NAME
1	10537961	Dura-Cyl 160 MP & MCR
1	10537987	Dura-Cyl 180 MP & MCR
1	10538007	Dura-Cyl 200 MP & MCR
1	10538023	Dura-Cyl 230 MP & MCR
1	10538040	Dura-Cyl 265 MP & MCR
1	10537979	Dura-Cyl 160 HP & MCR
1	10537995	Dura-Cyl 180 HP & MCR
1	10538015	Dura-Cyl 200 HP & MCR
1	10538031	Dura-Cyl 230 HP & MCR
1	10538058	Dura-Cyl 265 HP & MCR
1	10662770	Cryo-Cyl 80 HP
1	10662884	Cryo-Cyl 120 LP
1	10662892	Cryo-Cyl 180 LP
1	10662913	Cryo-Cyl 230 LP
1	10650357	Laser- Cyl 200
2	10580264	Argon
2	10580272	Oxygen
2	10580281	Nitrogen
2	10591140	Carbon Dioxide
2	10591131	Nitrous Oxide
4	N/R	(See Liquid Level Gauge Decals/Heads)(pg 63)
5	N/R	(See DOT/TC Data Plate)
6	3811599	Valve Tag – Gas Use
6	3811589	Valve Tag – Liquid
6	3811609	Valve Tag – Vent
6	3815029	Valve Tag – Vent/Gas Use

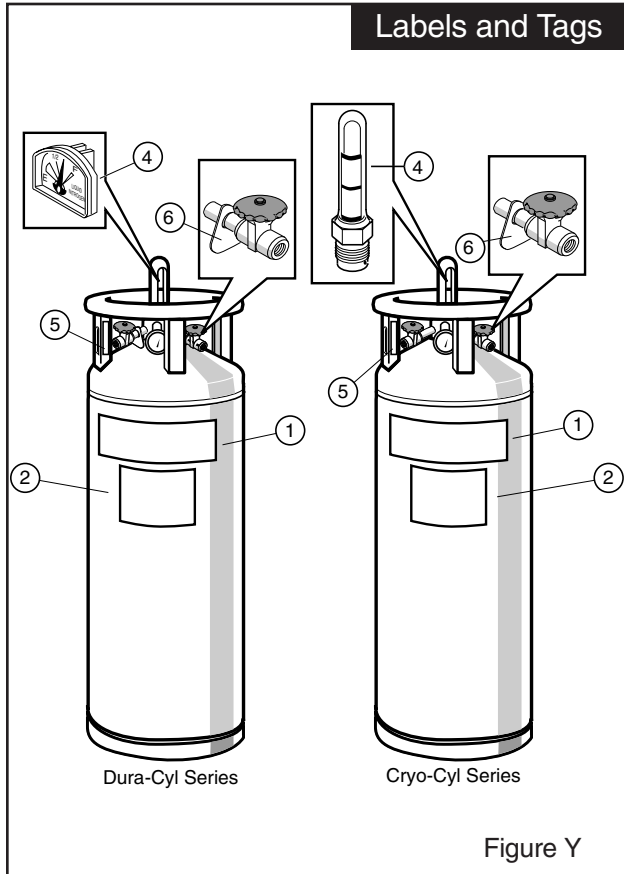

Figure Y

Reliquefying Solid CO₂

In the event the Dura-Cyl HP/Cryo-Cyl HP loses pressure and the contents become solidified, the following procedure should be used:

1. Locate and correct the reason for the pressure loss; refer to the troubleshooting tables above.
2. Connect the proper gas source to the vent valve on the frozen Dura-Cyl HP/Cryo-Cyl HP.
3. Open the vent and gas source valve on the frozen liquid cylinder and monitor its pressure.
4. Pressure in a frozen Dura-Cyl HP/Cryo-Cyl HP should rise to 60 psig (4.1 bar) and remain there. When the pressure starts to rise above 60 psig, it is an indication that the solid has reliquefied. Continue to raise the pressure to 200 to 300 psig (13.8 to 20.7 bar).

Note:

Depending on length of time contents have been frozen, the time to reliquefy could last from six minutes to two weeks. This should be done as soon as possible. It could take up to two full liquid cylinders to reliquefy a fully solidified tank.

Changing The Service Pressure

The inner pressure vessels used in the Dura-Cyl/Cryo-Cyl Series liquid cylinders are designed and rated to a maximum operating pressure by the DOT. All of the vessels have been proof tested for that rating. The maximum pressure rating is shown in the specification, section 5, and on the liquid cylinders data plate, figure G on page 10. DO NOT install a relief valve with a higher pressure than specified. Lower pressures are commonly used for limiting the maximum pressure of the liquid.

The relief valve can be changed in the following manner:

1. Open the vent valve and release all pressure from the vessel. If the liquid cylinder is in CO₂ service the vessel must be emptied of product.
2. Remove the relief valve. DO NOT attempt to repair or reset the relief valve.
3. Remove the metal identification tag.
4. Install the new identification tag and relief valve; use oxygen compatible thread sealant or teflon tape.
5. Pressurize the container and leak test with oxygen compatible snoop solution.

The following relief valve parts list shows the various pressure settings that are offered. The relief valves that are marked for CO₂ and N₂O are specially designed for those gas products.

Rego Relief Valve Part No.	Generant Part No.	Pressure Range (PSIG)
1810012	11884770	22
1810022	—	35
1810032	—	50
1810042	—	100
1810652	—	125
1811412	11884796	230
1810462	11884788	350
1812712	11892956	500

** Standard relief valves currently supplied are Generant. The above Rego valves are also supplied upon request.*

Changing Operating Pressure

The Dura-Cyl/Cryo-Cyl Series containers have preset operating pressures and preset pressure building and economizer regulators. These settings can be changed using the procedures that follow.

For Dura-Cyl MCR with Combo Regulator in Gas Service

When a container is dedicated to a gas withdrawal service, change of operation pressure requires adjustment as follows.

1. Release pressure in the container by opening the vent valve.
2. If the desired pressure setting is not within the regulator's range the regulator will have to be replaced as shown on page 62.
3. With liquid in the container, open the pressure building valve and observe the pressure gauge until it stops rising. The gauge will then indicate the pressure control regulator setting.
4. Turn the pressure control regulator screw clockwise to increase the pressure. Use the calibrated scale to approximate the desired setting. The pressure gauge will stop rising at the new regulator setting.
5. Continue adjusting the regulator until the desired pressure has been reached.
6. Vent the tank pressure and allow it to build up to confirm the pressure setting.

16 SERVICE AND MAINTENANCE

For Dura-Cyl with LCCM Pressure Control Manifold in Gas Service (Refer to Figure AA)

1. Close all four manual valves on the Dura-Cyl .
2. Back out adjusting knob (Item A) on pressure control manifold.
3. Release pressure in the container by opening the vent valve. (The container must be at least 1/2 full)
4. Close vent valve and turn the adjusting knob (Item A) until the knob registers a desired pressure setting.
5. With liquid in the container, open the pressure building valve (Item B) and observe the pressure gauge until it stops rising. The gauge will then indicate the pressure control manifold setting.
6. Turn the pressure control manifold knob (Item A) clockwise to increase the pressure. The pressure gauge will stop rising at the new regulator setting.
7. Continue adjusting the regulator until the desired pressure has been reached.

For Dura-Cyl/Cryo-Cyl in Liquid Service

When a container is dedicated to a liquid dispensing service, change the operating pressure as follows.

1. Release pressure in the container by opening the vent valve.
2. Isolate the pressure control regulator by turning off the pressure builder valve. The heat leak of the liquid cylinder will be enough to maintain the pressure at 22 psig (1.5 BAR).
3. Replace standard pressure relief valve with one to maintain the desired operation pressure (22

psig is normal). Use an oxygen compatible liquid thread sealant (or Teflon tape) to prevent leaking.

4. Pressure test all new joints using an oxygen compatible leak test solution.

Installing the LCCM (Dura- Cyl Only)

1. Install the four screws and washers into the manifold. (Figure BB)
2. Apply a thin layer of Halocarbon™ grease to each side of each ferrule, and to the threaded end of the four screws.
3. Install the gasket on the end of the manifold.
4. Place the manifold on the knuckle of the liquid cylinder, with the screws lined up with the tapped holes. Use your fingers on a 5/32" hex key to start the four screws.
5. Tighten all screws "finger tight."
6. Referring to figure BB for the proper torque sequence, torque each screw to 50 in. lbs.
7. Using the same sequence, torque each screw to 70 in. lbs.

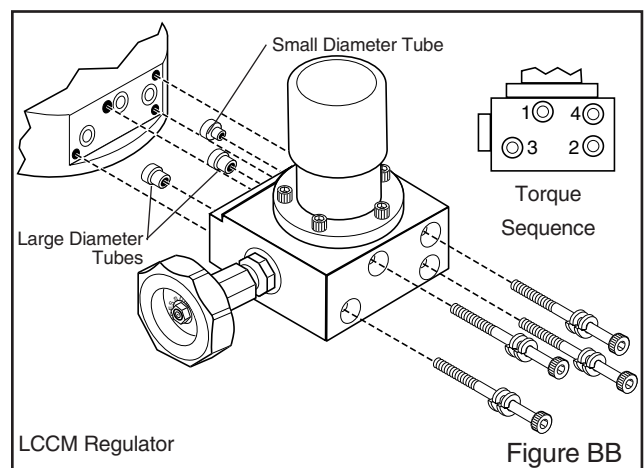
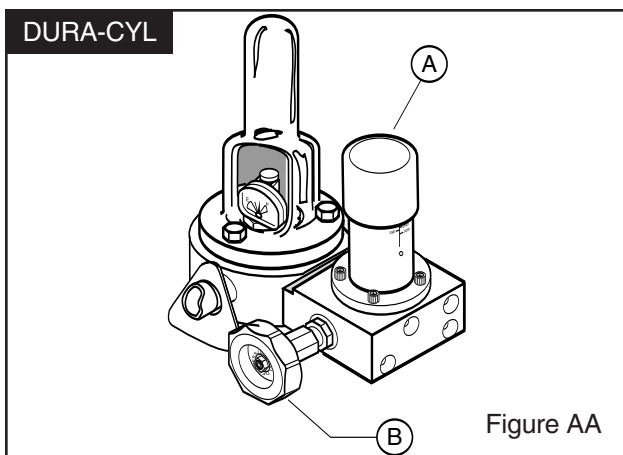

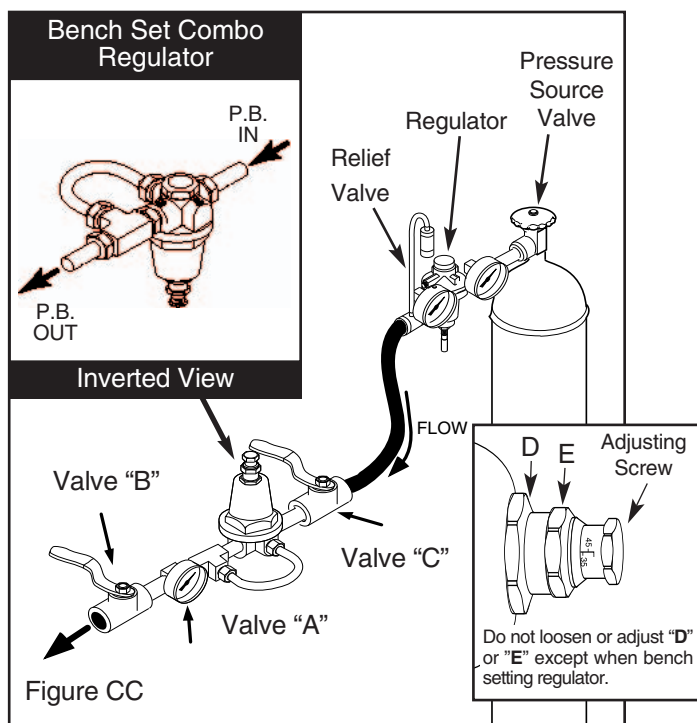

Bench Setting a Pressure Control Regulator For The CRYO-CYL

1. Connect the pressure control regulator to a nitrogen pressure source as shown in figure CC.
2. Connect economizer out port to tee on PB outside of regulator with a piece of tubing.
3. Close valve B.
4. Open the pressure source valve (follow appropriate safety rules.)
5. Open valve C slowly.
6. Pressure gauge A will indicate the pressure to which the regulator has been set. The pressure can be increased by turning the adjusting screw in. The pressure may be decreased by turning the screw out; however, after each adjustment outward it will be necessary to open and then close valve B to relieve excess pressure.
7. This setting should match the calibrated scale. If it does not go to step #8.
8. Loosen lock nut "D" and adjust screw "E" until calibrated scale matches set pressure. When completed, tighten locknut "D". "D" and "E" are only to be loosened or adjusted during bench setting procedure.

Note: Factory Setting:

For Dura-Cyl MCR MP Series 125 psig
 For Cryo-Cyl HP Series 300 psi

Level Gauge

The liquid level gauge in the Cryo-Cyl LP model is a float and spring that approximates the amount of product in the container. The design of this gauge makes it possible to use the same float and spring for nitrogen, oxygen and argon. However, the liquid level decal must be changed for each product. The decals are marked N for nitrogen, O for oxygen, and A for argon.

If the gauge is malfunctioning it should be removed from the container and repaired. The following procedure should be followed: (See figure DD - page 63)

1. Open the vent valve and release any pressure that is in the container.
2. Remove the nylon sight gauge protector (Item 3).
3. Unscrew and remove the sight gauge (Item 5).
4. Replace any damaged parts, stretched springs or bent floats.
5. Adjust the sight gauge assembly as follows
 - a. Hold the sight gauge assembly allowing the float to hang freely.
 - b. The top of the indicator's white tip should be in the empty zone.
 - c. Loosen the spring retainer (Item 8) and adjust the spring up and down the float rod until the indicator hangs freely in the right location. Tighten the spring retainer.
 - d. Replace the O-Ring/Gasket (Item 7).
 - e. Insert the float and sight gauge assembly into the container. Make sure that it engages in the float guide located approximately 21 inches into the container.
 - f. Tighten the sight gauge to 1/4 turn past hand tight (150in/lb) and replace the protector.

WARNING: Remove all pressure from the Cryo-Cyl before repairing the liquid level gauge. Gloves should be worn when handling the float rod to prevent burns.

WARNING: DO NOT clean the plastic sight gauge with solvent cleaners.

16 SERVICE AND MAINTENANCE

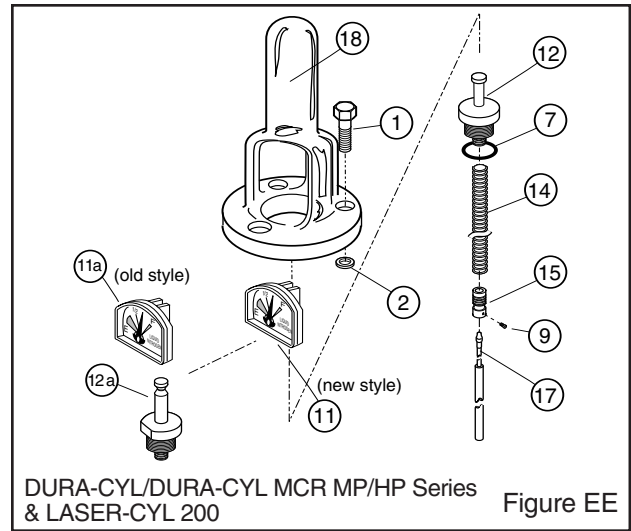
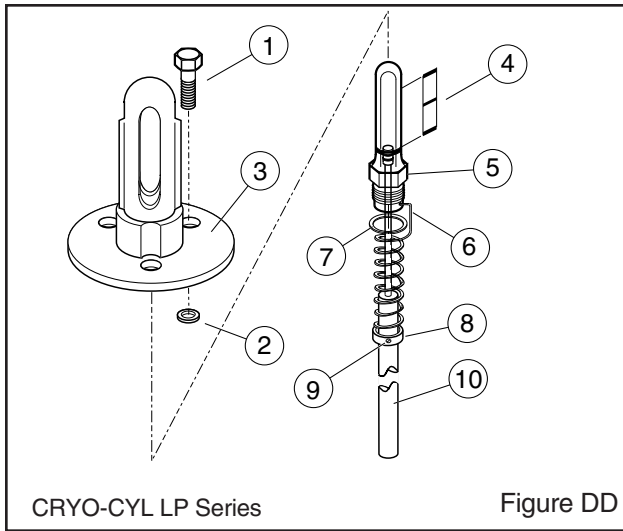

Item	Part No	Qty	Spares*	Description
1	2910501	3		Stainless Steel Screw - 1/4'-20NC X 5/8"
2	2910601	3		Lockwasher - 1/4" Split Type S.S.
3	5410446	1	1	Sight Gauge Protector - Sight Glass (Blue) (MP)
3	5410486	1	1	Sight Gauge Protector - Sight Glass (Yellow) (LP)
3	5410476	1	1	Sight Gauge Protector - Sight Glass (Orange) (HP)
4	3830659	1	1	Sight Gauge Decal (Nitrogen)
4	3830569	1	1	Sight Gauge Decal (Oxygen)
4	3830579	1	1	Sight Gauge Decal (Argon)
4	3830799	1	1	Sight Gauge Decal (Carbon Dioxide)
4	3831069	1	1	Sight Gauge Decal (Nitrous Oxide)
5	5411086	1	1	Liquid Level Sight Gauge
6	5410591	1		Extension Spring
7	2300094	1	1	O-Ring (Silicone)
8**	5410582	1		Spring Retainer - 120,160, 230, and 265 w/ Sight Glass
8**	10561266	1		Spring Retainer - 180 and 200 w/ Sight Glass
9**	2952321	1		Set Screw
10	10659280	1		Float Rod Assy - Cryo-Cyl 120LP w/ Sight Glass
10	9091609	1		Float Rod Assy - 160 w/ Sight Glass
10	5411369	1		Float Rod Assy - Cryo-Cyl 180LP w/ Sight Glass
10	5410769	1		Float Rod Assy - 200 w/ Sight Glass
10	9092339	1		Float Rod Assy - Cryo-Cyl 230 LP w/ Sight Glass
10	10616095	1		Float Rod Assy - 265 w/ Sight Glass
11	10591342	1	1	Liquid Level Indicator (Nitrogen) (for tanks built after 1/1/95)
11	10591385	1	1	Liquid Level Indicator (Oxygen) (for tanks built after 1/1/95)
11	10591377	1	1	Liquid Level Indicator (Argon) (for tanks built after 1/1/95)
11	10591369	1	1	Liquid Level Indicator (Carbon Dioxide) (for tanks built after 1/1/95)
11	10591351	1	1	Liquid Level Indicator (Nitrous Oxide) (for tanks built after 1/1/95)
11a	10591406	1		Liquid Level Indicator (Nitrogen) (for tanks built before 1/1/95)
11a	10591431	1		Liquid Level Indicator (Oxygen) (for tanks built before 1/1/95)
11a	10591393	1		Liquid Level Indicator (Argon) (for tanks built before 1/1/95)
11a	10591422	1		Liquid Level Indicator (Carbon Dioxide) (for tanks built before 1/1/95)
11a	10591414	1		Liquid Level Indicator (Nitrous Oxide) (for tanks built before 1/1/95)
12	10591511	1		Level Gauge Plug
12a	5410992	1		Level Gauge Plug (Pre-1995 Cylinders Only - Use with 11a)
14	5411029	1		Extension Spring
15	5411012	1		Spring Retainer 160, 180
15	5411622	1		Spring Retainer 230, 265
17	9094119	1		Float Rod Assy (Magnetic) 160
17	5411779	1		Float Rod Assy (Magnetic) 180/200
17	5411729	1		Float Rod Assy (Magnetic) 230/265
17	10602291	1		Float Rod Assy (Magnetic) Cryo-Cyl 80HP
18	10534583	1	1	Sight Gauge Protector - (Blue) MP
18	10534567	1	1	Sight Gauge Protector - (Orange) HP

* Recommended Spare Parts

Rebuilding the Operational Valves

The valves that are used on the Dura-Cyl/Cryo-Cyl models have a spring loaded rotary stem. This automatically compensates for thermal shrinkage and wear.

When a defective valve is suspected, follow this procedure to repair it.

Disassembly and Repair Procedure

Caution: To avoid binding due to freezing at cryogenic temperatures, entry of moisture into the upper valve stem area must be prevented. Seals, gaskets and washers must be in good condition and installed carefully and properly. Torque recommendations must be strictly followed.

Disassembly

1. Open valve by turning handwheel counterclockwise as far as it will go to release any trapped gas in the system.

CAUTION: Do not apply force after valve is fully open.

2. Using a screwdriver, remove handwheel screw and washer (Items 3 & 14) by turning counterclockwise to allow removal of spring retainer, washer, spring, seal washer, seal, handwheel, and bonnet washers (Items 2, 8, 4, 13, 10, 1 and 7). Discard these parts.
3. Using a large adjustable wrench to hold valve body, remove and discard bonnet (Item 5) by turning counterclockwise with a 15/16" socket wrench that is capable of developing at least 1000 in/lbs. torque.
4. Remove these parts from the valve body and discard: stem, stem gasket, seat disc and nipple assembly, and bushing.

5. Inspect body and clean if necessary, be sure interior and seal areas are free of dirt, residue, and foreign particles.

CAUTION: Do not scratch or mar internal surfaces of valve.

Reassembly

1. Partially thread seat disc and nipple assembly (Item 12) (seat disc first), into large end of bushing (Item 9), leaving tang of nipple assembly exposed about 1/3" beyond top of bushing (nipple must rotate freely in bushing).
 2. Insert seat disc and nipple assembly (Item 12) (seat disc first), with attached bushing, into valve body until properly seated.
 3. Place stem gasket (Item 15) carefully over stem (Item 6) convex side facing downward.
 4. Insert slotted end of stem into valve body, making sure that slot fully engages tang of seat disc and nipple assembly.
 5. Place bonnet (Item 5) over stem and, while holding square end of stem to keep it from turning, thread bonnet into valve body. Hold body with one wrench and, using another wrench (15/16" socket), tighten bonnet to 1000 in/lbs. torque.
- CAUTION: Hex section of bonnet (Item 5) must be free of burrs or raised edges and top of bonnet must be absolutely flat to provide an effective seal with bonnet gasket washer (Item 7).*
6. Install bonnet washer (Item 7) over stem (Item 6) on bonnet.

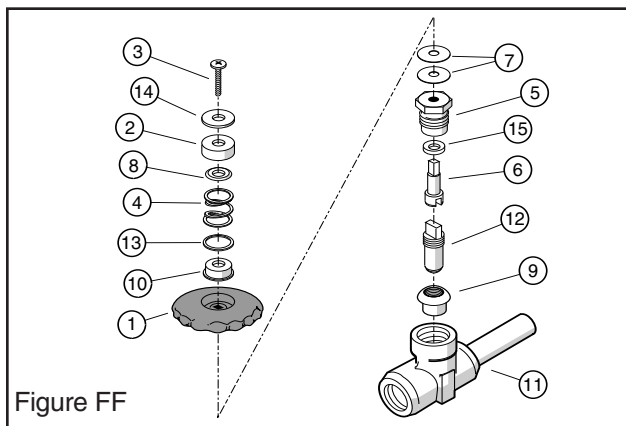

Figure FF

Item	Description	Qty	Part Number
1	Handwheel	1	Included in Valve Repair Kit P/N 9715759 (Except Item 11 which is not available as a repair part).
2	Spring Retainer	1	
3	Screw	1	
4	Spring	1	
5	Bonnet	1	
6	Stem	1	
7	Bonnet Washer	2	
8	Washer	1	
9	Bushing	1	
10	Seal	1	
11	Body and Tube	1	
12	Seat Disc & Nipple Assembly	1	
13	Seal Washer	1	
14	Washer	1	
15	Gasket	1	

17 APPLICATIONS AND ACCESSORIES

7. Place handwheel (Item 1) over stem and on bonnet.
8. Install seal (Item 10) over stem into recess of handwheel.
9. Install seal washer (Item 13) over seal at the bottom of handwheel recess as shown.
10. With the flat side facing downward, place retainer washer (Item 8) on top of seal.
11. Align the holes of these parts and place spring (Item 4) over seal.
12. Place spring retainer over assembly as shown, keeping center hole aligned with parts installed in steps 6-11.
13. Install washer and screw (Items 3 & 14) over retainer. Tighten firmly with a screwdriver, turning clockwise.
14. Turn handwheel (Item 1) fully clockwise to close valve.
15. Pressurize system, check valve for proper operation and check all seal points for leaks by inspecting thoroughly.

GENERAL

This section of the Dura-Cyl/Cryo-Cyl Series liquid cylinder service manual describes the optional accessories that are available from Chart to aid in; Handling, Filling, Liquid Withdrawal, or Gas Use Applications.

Handling Carts and Roller Bases

Handling carts are available that will connect to the liquid cylinder, tip it back and allow it to be rolled to the desired location. There are two styles of these carts. Model ULG629-13 has pneumatic tires and should be used where a rough or uneven floor is encountered. Model ULG668-77 operates the same as the previous model but has hard rubber wheels.

Handling carriages attach to the bottom of the liquid cylinder and hold it upright. They have a caster or wheel base and a handle that allows the carriage to be pulled to the desired location. These types of handling devices should be used on flat, smooth floors.

The handling base chart shows the types of handling devices available for the various models of Dura-Cyl/Cryo-Cyl Series liquid cylinders. Note: Some models of liquid cylinders have a permanently mounted caster base (see page 44, section 14).

	CRYO-CYL 80 HP	DURA-CYL 160 MP	DURA-CYL 160 HP	DURA-CYL 180 MP	DURA-CYL 180 HP	DURA-CYL 200 MP	DURA-CYL 200 HP	DURA-CYL MCR 160 MP	CRYO-CYL MCR 160 HP	DURA-CYL 180 LP	DURA-CYL MCR 180 MP	DURA-CYL MCR 180 HP	DURA-CYL MCR 200 MP	DURA-CYL MCR 200 HP
Harper Cart ULG 629-51 97-1142-9			X	X	X	X	X	X	X	X	X	X	X	X
Harper Cart ULG 668-77 97-1141-9			X	X	X	X	X	X	X	X	X	X	X	X
Handling Carriage	X	X	X	X	X	X	X	X	X	X	X	X	X	X

Filling

The filling of liquid cylinders can be done more economically if the liquid fill system uses a Chart Lo-Loss System. The Lo-Loss System automatically adjusts the liquid cylinders vent gas flow to minimize the filling loss while maintaining quick filling times. Order Chart form # 2072 for more information on the Lo-Loss System.



The filling of low pressure dewars of oxygen or argon can be done more economically with a Chart Cryo-Fill System. This system uses low cost liquid nitrogen to cool down the liquid oxygen or argon before it is delivered to the cryogenic storage dewar. The cooler liquid will give off less vapor (cost savings) as it is transferred. Order Chart form # 2148 for more information on the Cryo-Fill System.

Liquid Withdrawal

Flexible Transfer Hoses for cryogenic liquids are available in 3/8" and 1/2" nominal diameters and 6 foot lengths. These hoses are made with an all stainless steel construction and come equipped for oxygen or inert service. Order these hoses from Chart and specify the intended service.

Phase Separator will help keep the liquid from splashing while it is transferred into an upon dewar.

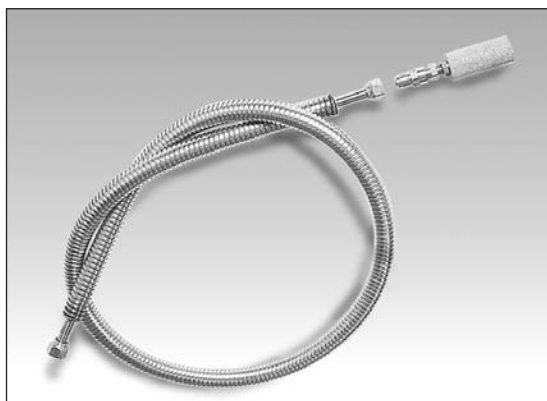

Phase separators are available from Chart in standard hose sizes from 1/8" to 1" thread size.

Gas Use Applications

The Dura-Cyl/Cryo-Cyl Series liquid cylinders are equipped with an internal vaporizer to provide gas to various applications. Chart offers devices to aid in the gas delivery.

M-45 Manifold

An automatic liquid cylinder manifold for the continuous supply of gaseous oxygen, nitrogen, argon, carbon dioxide, or nitrous oxide to a specific application. The M-45 will supply a continuous gas supply from up to six liquid cylinders at up to 350 psig (24.1 BAR).



Hospital Kit

The hospital kit can be used in conjunction with the M-45 manifold to control the high pressure reserve cylinders required in all bulk medical oxygen systems. The hospital kit contains the switches for alarms as required by NFPA Bulletin 56F. Order Chart's Use Manual form 2038 for more details.



General

Cryogenic containers, stationary or portable, are from time to time subjected to assorted environmental conditions of an unforeseen nature. This safety bulletin is intended to call attention to the fact that whenever a cryogenic container is involved in any incident whereby the container or its safety devices are damaged, good safety practices must be followed. The same holds true whenever the integrity or function of a container is suspected of abnormal operation.

Good safety practices dictate that the contents of a damaged or suspect container be carefully emptied as soon as possible. Under no circumstances should a damaged container be left with product in it for an extended period of time. Further, a damaged or suspect container should not be refilled unless the unit has been repaired and recertified.

Incidents which require that such practices be followed include: Highway accidents, immersion of a container in water, exposure to extreme heat or fire, and exposure to most adverse weather conditions (earthquakes, tornados, etc.). As a rule of thumb, whenever a container is suspected of abnormal operation, or has sustained actual damage, good safety practices must be followed.

In the event of known or suspected container vacuum problems (even if an extraordinary circumstance such as those noted above has not occurred), do not continue to use the unit. Continued use of a cryogenic container that has a vacuum problem can lead to possible embrittlement and cracking. Further, the carbon steel jacket could possibly rupture if the unit is exposed to inordinate stress conditions caused by an internal liquid leak.

Prior to reusing a damaged container, the unit must be tested, evaluated, and repaired as necessary. It is highly recommended that any damaged container be returned to Chart Inc. for repair and recertification.

The remainder of this safety bulletin addresses those adverse environments that may be encountered when a cryogenic container has been severely damaged. These are oxygen deficient atmospheres, oxygen enriched atmospheres, and exposure to inert gases.

Oxygen Deficient Atmospheres

The normal oxygen content of the air is approximately 21%. Depletion of oxygen content in air, either by combustion or by displacement by inert gas, is a potential hazard and users should exercise suitable precautions.

One aspect of this possible hazard is the response of humans when exposed to an atmosphere containing only 8 to 12% oxygen. In this environment, unconsciousness can be immediate with virtually no warning.

When the oxygen content of air is reduced to about 15 or 16%, the flame of ordinary combustible materials, including those commonly used as fuel for heat or light, may be extinguished. Somewhat below this concentration, an individual breathing the air is mentally incapable of diagnosing the situation because the onset of symptoms such as sleepiness, fatigue, lassitude, loss of coordination, errors in judgment and confusion can be masked by a state of "euphoria", leaving the victim with a false sense of security and well-being.

Human exposure to atmospheres containing 12% or less oxygen leads to rapid unconsciousness. Unconsciousness can occur rapidly, rendering the user essentially helpless. This can occur if the condition is reached by an immediate change of environment, or through the gradual depletion of oxygen. Most individuals working in or around oxygen deficient atmospheres rely on the "buddy system" for protection – obviously, the "buddy" is equally susceptible to asphyxiation if he or she enters the area to assist an unconscious partner unless equipped with a portable air supply. Best protection is obtained by equipping all individuals with a portable supply of respirable air. Life lines are acceptable only if the area is essentially free of obstructions and individuals can assist one another without constraint.

If an oxygen deficient atmosphere is suspected or known to exist:

1. Use the "buddy system". Use more than one "buddy" if necessary to move a fellow worker in an emergency.
2. Both the worker and the "buddy system" should be equipped with self-contained or air-line breathing equipment.

Oxygen Enriched Atmospheres

An oxygen enriched atmosphere occurs whenever the normal oxygen content of the air is allowed to rise above 23%. While oxygen is nonflammable, ignition of combustible materials can occur more readily in an oxygen-rich atmosphere than in air; and combustion proceeds at a faster rate, although no more total heat is released.

It is important to locate an oxygen system in a well-ventilated location since oxygen-rich atmospheres may collect temporarily in confined areas during the functioning of a safety relief device or leakage from the system.

Oxygen system components, including but not limited to, containers, valves, valve seats, lubricants, fittings, gaskets and interconnecting equipment including hoses, shall have adequate compatibility with oxygen under the conditions of temperature and pressure to which the components may be exposed in the containment and use of oxygen. Easily ignitable materials shall be avoided unless they are parts of equipment or systems that are approved, listed, or proved suitable by test or by past experience.

Compatibility involves both combustibility and ease of ignition. Materials that burn in air may burn violently in pure oxygen at normal pressure, and explosively in pressurized oxygen. In addition, many materials that do not burn in air may do so in pure oxygen, particularly when under pressure. Metals for containers and piping must be carefully selected, depending on service conditions. The various steels are acceptable for many applications, but some service conditions may call for other materials (usually copper or its alloys) because of their greater resistance to ignition and lower rate of combustion.

Similarly, materials that can be ignited in air have lower ignition energies in oxygen. Many such materials may be ignited by friction at a valve seat or stem packing, or by adiabatic compression produced when oxygen at high pressure is rapidly introduced into a system initially at low pressure.

Nitrogen And Argon

Nitrogen and argon (inert gases) are simple asphyxiants. neither gas will support or sustain life and can produce immediate hazardous conditions through the displacement of oxygen. Under high pressure these gases may produce narcosis, even though an adequate oxygen supply sufficient for life is present.

Nitrogen and argon vapors in air dilute the concentration of oxygen necessary to support or sustain life. Inhalation of high concentrations of these gases can cause anoxia, resulting in dizziness, nausea, vomiting, or unconsciousness and possible death. Individuals should be prohibited from entering areas where the oxygen content is less than 19% unless equipped with a self-contained breathing apparatus. Unconsciousness and death may occur with virtually no warning if the oxygen concentration is below approximately 8%. Contact with cold nitrogen or argon liquid can cause cryogenic (extreme low temperature) burns and freeze body tissue.

Persons suffering from lack of oxygen should be immediately moved to areas with normal atmospheres. **Self-contained breathing apparatus may be required to prevent asphyxiation of rescue workers.** Assisted respiration and supplemental oxygen should be given if the victim is not breathing. If cryogenic liquid or cold boil-off gas contacts the skin or eyes, the affected area should be promptly flooded or soaked with tepid water (105-115°F; 41-46° C). **Do not use hot water.** Cryogenic burns which result in blistering or deeper tissue freezing should be examined promptly by a physician.

Additional information on nitrogen and argon gas is available in CGA Pamphlet P-9. Write to:

Compressed Gas Association, Inc
New York, NY 10110

Chart Inc.
407 7th Street NW
New Prague, MN 56071