

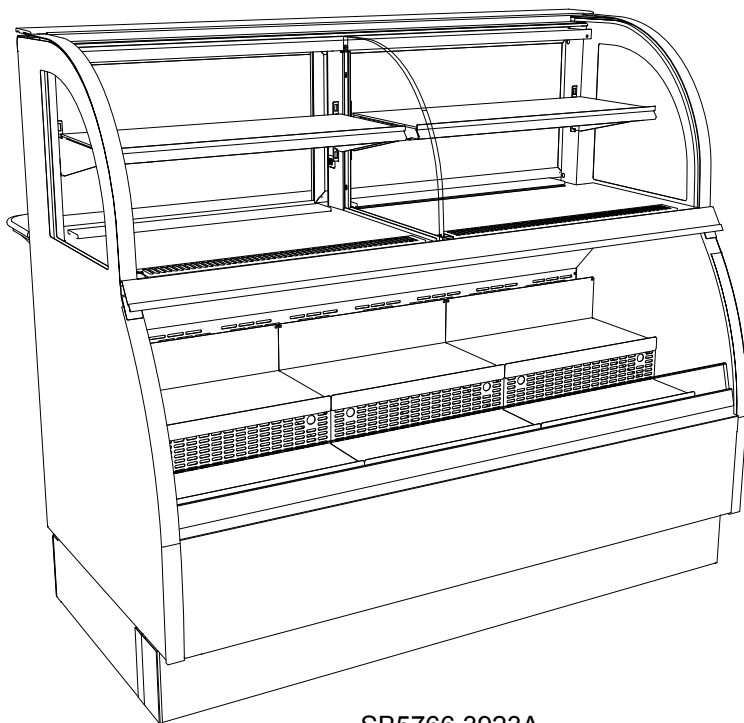

# INSTALLATION & OPERATING MANUAL

P/N 54100

**SELF-CONTAINED REFRIGERATED SERVICE / SELF-SERVE UNITS**



SB5766.3923A

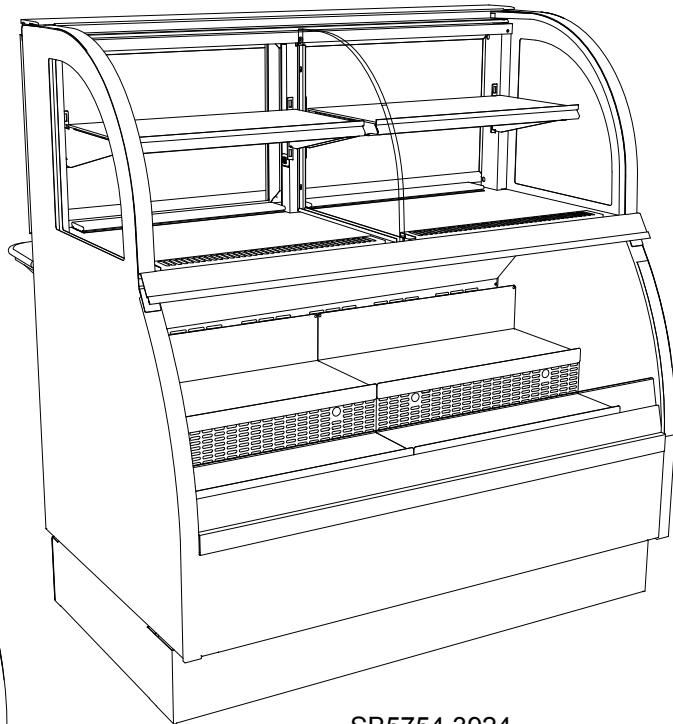

SB5754.3924

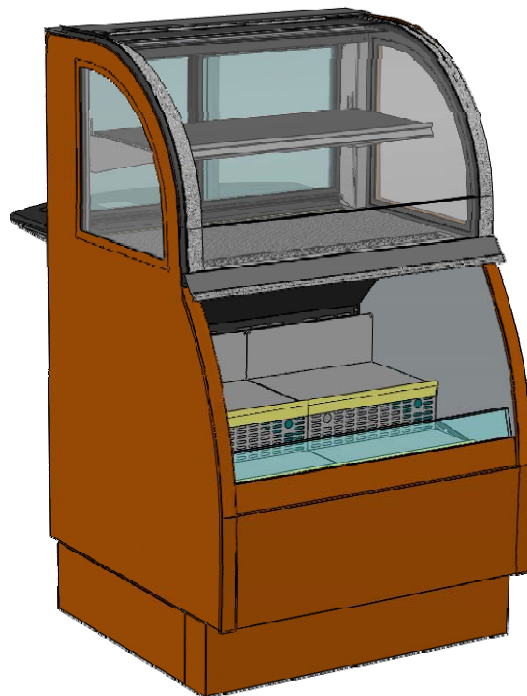

SB5735

- Model SB5735.....34 1/2" L\* x 33" D\*\* x 58 7/8" H~
- Model SB5754.3924.....54" L\* x 33" D\*\* x 58 7/8" H~
- Model SB5766.3923.....66" L\* x 33" D\*\* x 58 7/8" H~
- Model SB5766.3923A.....66" L\* x 33" D\*\* x 58 7/8" H~
- Model SB5766.4999.....66" L\* x 33" D\*\* x 58 7/8" H~
- Model SB5766.5106.....66" L\* x 33" D\*\* x 58 7/8" H~

\* With End Panels

\*\* 47 1/8" With Rear Ledge upright

~ With Adjustable Levelers Extended 1 5/8" Below Base Frame

Certification: NSF-7, CRMA, UL/CSA



888 E. Porter Road · Muskegon, MI 49441 Phone: 231.798.8888 Fax: 231.798.4960 www.structuralconcepts.com

## TABLE OF CONTENTS

<b>OVERVIEW / NSF® TYPE / COMPLIANCE / WARNINGS / PRECAUTIONS / WIRING / PLUGS .....</b>	<b>3-4</b>
<b>REFRIGERATION ASS'Y REMOVAL, CASE REMOVAL AND LEVELER ADJUSTMENT .....</b>	<b>5</b>
<b>START-UP AND OPERATION .....</b>	<b>6-7</b>
<b>SECURITY .....</b>	<b>8</b>
<b>MAINTENANCE AND OPERATION .....</b>	<b>9-11</b>
<b>ELECTRICAL FUNDAMENTALS .....</b>	<b>12</b>
<b>REFRIGERATION FUNDAMENTALS .....</b>	<b>13-14</b>
<b>HOT GAS CONDENSATE EVAPORATIVE SYSTEM OPERATION.....</b>	<b>15</b>
<b>LOAD LEVEL GUIDELINES [APPLICABLE TO ALL MODELS] .....</b>	<b>16</b>
<b>SERIAL LABEL LOCATION &amp; INFORMATION LISTED / TECH INFO &amp; SERVICE .....</b>	<b>17</b>
<b>ILLUSTRATED PARTS BREAKDOWN FOR MODEL SB5766.3923/3923A (SIMILAR TO OTHER MODELS) .....</b>	<b>18-20</b>
<b>PARTS LIST FOR MODEL SB5766.3923/3923A (SIMILAR TO OTHER MODELS) .....</b>	<b>21</b>
<b>ILLUSTRATED PARTS BREAKDOWN / PARTS LIST FOR MODEL SB5735 CONDENSER PKG ...</b>	<b>22</b>
<b>CLEANING SCHEDULE [TO BE PERFORMED BY STORE PERSONNEL] .....</b>	<b>23</b>
<b>CLEANING SCHEDULE [TO BE PERFORMED BY TRAINED SERVICE PROVIDERS ONLY] .....</b>	<b>24</b>
<b>TROUBLESHOOTING [TO BE PERFORMED BY STORE PERSONNEL .....</b>	<b>25-26</b>
<b>TROUBLESHOOTING [TO BE PERFORMED BY TRAINED SERVICE PROVIDERS ONLY] .....</b>	<b>27-29</b>
<b>TROUBLESHOOTING [BY TRAINED SERVICE PROVIDERS ONLY] - CONDENSING SYSTEM</b>	<b>30</b>
<b>TROUBLESHOOTING [BY TRAINED SERVICE PROVIDERS ONLY] - EVAPORATOR SYSTEM</b>	<b>31</b>
<b>PREVENTIVE MAINTENANCE - HONEYCOMB AIR DIFFUSERS [TRAINED SERVICE PROVIDERS ONLY] .....</b>	<b>32</b>
<b>CAREL® CONTROLLER - PROGRAMMING THE INSTRUMENT .....</b>	<b>33</b>
<b>CAREL® CONTROLLER - USER INTERFACE DISPLAY &amp; SUMMARY TABLE OF ALARM AND SIGNALS: DISPLAY, BUZZER AND RELAY .....</b>	<b>34</b>
<b>CAREL® CONTROLLER - SUMMARY TABLE OF OPERATING PARAMETERS (AFTER PROGRAMMING KEY) .....</b>	<b>35</b>
<b>QUARTERLY PREVENTIVE MAINTENANCE FORM .....</b>	<b>36</b>
<b>SCC TECHNICAL SERVICE CONTACT INFORMATION &amp; STARBUCKS LIMITED WARRANTY ....</b>	<b>37</b>

**OVERVIEW**

- These Structural Concepts merchandisers are designed to merchandise pre-chilled packaged products at 41 °F [5 °C] or less product temperatures.
- *This self-contained refrigerated unit is a barista serve unpackaged food and customer self serve packaged food and drink case.*
- Cases should be installed and operated according to this operating manual's instructions to ensure proper performance.
- Improper use will void warranty.

**NSF® TYPE**

This unit is designed for the display of products in ambient store conditions where temperatures and humidity are maintained within a specific range.

- For NSF® Type 1 Conditions (most cases): ambient conditions are to be at 55% maximum humidity and maximum temperatures of 75 °F [24 °C].
- For NSF® Type 2 Conditions: ambient conditions are to be at 60% maximum humidity and maximum temperatures of 80 °F [27 °C].

- If unsure if unit is NSF® Type 1 or 2, see tag next to serial label. See **SERIAL LABEL LOCATION & INFORMATION LISTED / TECH INFO & SERVICE** section in this manual for sample serial labels.

**COMPLIANCE**

- Performance issues when in violation of applicable NEC, federal, state and local electrical and plumbing codes are not covered by warranty.
- See below compliance guideline.

**WARNINGS**

- This sheet contains important warnings to prevent injury or death.
- Please read carefully!

**PRECAUTIONS, CORD/PLUG MAINTENANCE & WIRING DIAGRAM INFORMATION**

- See next page for **PRECAUTIONS, CORD/PLUG MAINTENANCE** and **WIRING DIAGRAM** information.



**ATTENTION  
INSTALLER**

**COMPLIANCE**  
This equipment **MUST** be installed in compliance with all applicable NEC, federal, state and local electrical and plumbing codes.

**WARNING**

**ELECTRICAL  
HAZARD**



**WARNING**  
Risk of electric shock. Disconnect power before servicing unit.  
**CAUTION!** More than one source of electrical supply is employed with units that have separate circuits.  
*Disconnect ALL ELECTRICAL SOURCES before servicing.*

**WARNING**

**KEEP  
HANDS  
CLEAR**



**WARNING**  
Hazardous moving parts. Do not operate unit with covers removed.  
Fan blades may be exposed when deck panel is removed.  
Disconnect power before removing deck panel.

**WARNING**

**HOT  
SURFACE**



**WARNING**  
Condensate Pan is Hot!  
Disconnect and allow to cool  
before cleaning or removing from case.

**PRECAUTIONS**

- This sheet contains important precautions to prevent damage to unit or merchandise.
- Please read carefully!
- See previous page for specifics on **OVERVIEW, NSF TYPE, COMPLIANCE** and **WARNINGS**.

**WIRING DIAGRAM**

- Each case has its own wiring diagram folded and in its own packet.
- Wiring diagram placement may vary; it may be placed near ballast box, field wiring box, raceway cover, or other related location.



**CAUTION! LAMP REPLACEMENT GUIDELINES**  
 Fluorescent lamps have been treated to resist breakage and must be replaced with similarly treated lamps.

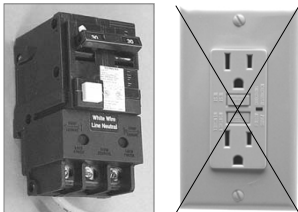

**CAUTION! GFCI BREAKER USE REQUIREMENT**  
 If N.E.C. (National Electric Code) or your local code requires GFCI (Ground Fault Circuit Interrupter) protection, you **MUST** use a GFCI breaker in lieu of a GFCI receptacle.



**CAUTION! POWER CORD AND PLUG MAINTENANCE**  
 Risk of electric shock. If cord or plug becomes damaged, replace only with cord and plug of same type.

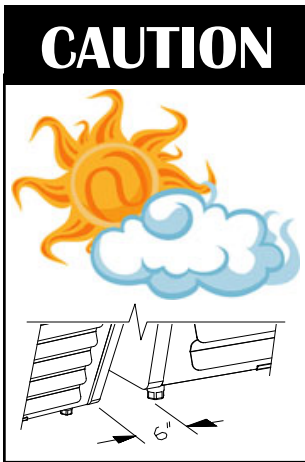

**CAUTION! ADVERSE CONDITIONS / SPACING ISSUES**

- Performance issues caused by adverse conditions are **NOT** warranted.
- End panels must be tightly joined or kept at least **6-inches** away from any structure to prevent condensation.
- Unit must be kept at least **15-feet** from exterior doors, overhead HVAC vents or any air curtain disruption to maintain proper temperatures.
- Unit must not be exposed to direct sunlight or any heat source (ovens, fryers, etc.).
- Tile floors, low ceilings or small rooms increase noise level. Whisper Cool compressor blankets or remote units resolve noise level issues.
- Keep at least **8-inch** clearance above unit for air discharge (self-contained units only).

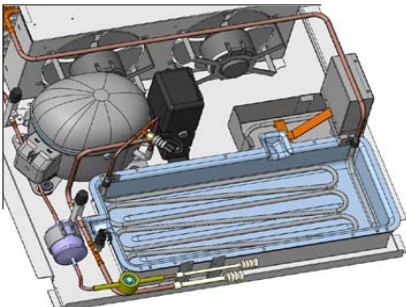

**CAUTION! CHECK CONDENSATE PAN POSITION & PLUG**  
 Water on flooring can cause extensive damage!  
 Before powering up unit, check and confirm that:

- Condensate pan is **DIRECTLY UNDER** condensate drain.
- Condensate pan plug is securely plugged into receptacle.
- Overflow pan has plug connected to its box. Units with optional Clean Sweep™ **MUST HAVE 2** plugs connected.

## REFRIGERATION ASSEMBLY REMOVAL, CASE REMOVAL AND LEVELER ADJUSTMENT

### 1. Removing Refrigeration Assembly

- **Note:** Retain screws that are removed from the **CASE** shipping brackets (Screws will be used as Toe-Kick fasteners).
- Remove front panel.
- Lift front panel upward from the lower edge, approximately one half inch to detach from the retainer hooks.
- Remove all shipping brackets from units base and compressor.
- Reuse shipping bracket screws for Toe-Kick mounting.
- **Note:** Make sure all hoses and power cords are disconnected before completely removing compressor from unit.
- The compressor base is on casters. Roll the assembly out half way straight out from the front of the case.
- Carefully lower assembly to floor.
- After compressor unit is removed, roll out of the way while locating and setting case.

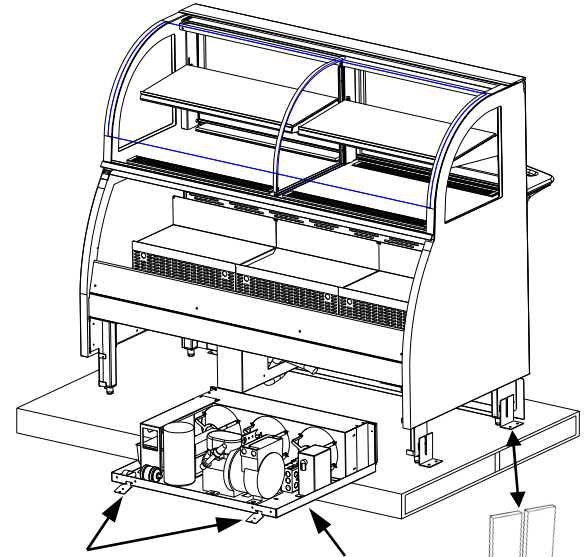

Refrigeration Assembly Shipping Brackets.

Refrigeration Assembly

**Note:** Illustration shown may differ slightly from your case.

### 2. Removing Case from Skid

- Slide case halfway off back of skid.
- Lower case onto back rear levelers.
- Tilt case back enough to free skid.
- Slide skid out from front of case, lower case to floor.

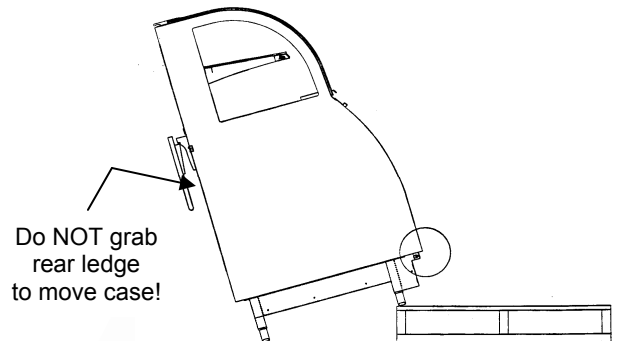

### 3. Leveling Case

- Levelers may need to be adjusted for proper height clearance to fully insert unit.
- Tools needed: level, pry bar, and adjustable wrench.
- Using a level, find the highest point on the case.
- Level the case to that highest point by turning the levelers up or down to the desired level position.

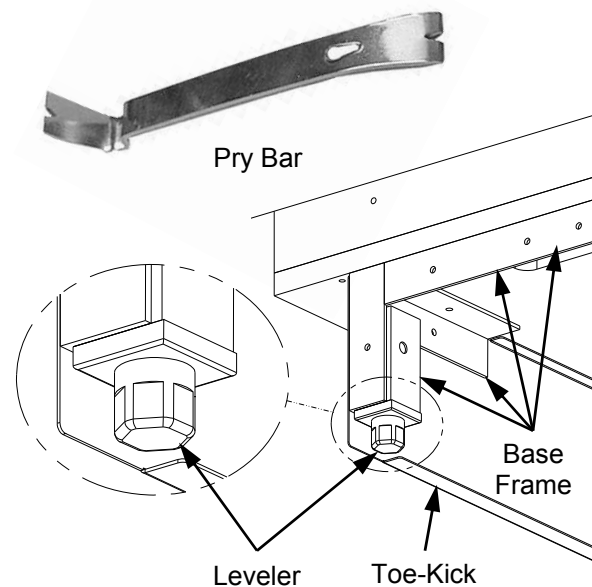

## START-UP AND OPERATION

### 1. Merchandiser Start-Up

- Remove rear toe-kick (by removing four screws, two at each end).
- Turn main power on. Switch (220V) is up and under rear raceway on right side of case.
- The Controller display will illuminate.
- Coil fans should turn on. From inside case, check for discharge air from front baffle to confirm that fans are functioning properly.
- When the case is in a start up mode or has been idle for a long period of time, the unit will require 75 minutes in order to pull-down temperature.
- **Self-Contained** refrigerated cases must maintain front airflow clearance of approximately twelve inches and rear airflow clearance of approximately six inches.
- Obstruction / restriction of air voids warranty.
- The interior case temperature is to reach 2 °C / 35 °F to 5 °C / 41 °F.
- **Note:** Case temperature is set at the factory, as determined by the case size. Temperature is controlled by a thermostat.
- If a temperature setting change is required, refer to the Temperature Controller section of this operating manual.
- **Note:** According to product displayed, Set point should be -6 °C / 22 °F to -3 °C / 26 °F. This will maintain the product temperature range. Settings lower than this can cause product to freeze.

### 2. Set Point & Differential Adjustment Guideline

- **Caution!** The Differential MUST be adjusted either up or down in tandem with the Set point.
- For example, if the Set point is raised from 22 °F to 26 °F (a 4 °F increase), the Differential must also be raised by 4 °F from (11 °F to 15 °F).
- Keeping the Set point and Differential temperatures 'in tandem' will maintain product temperature and prevent excessive compressor cycles.

### 3. See Next Page For Fluorescent Light Guidelines

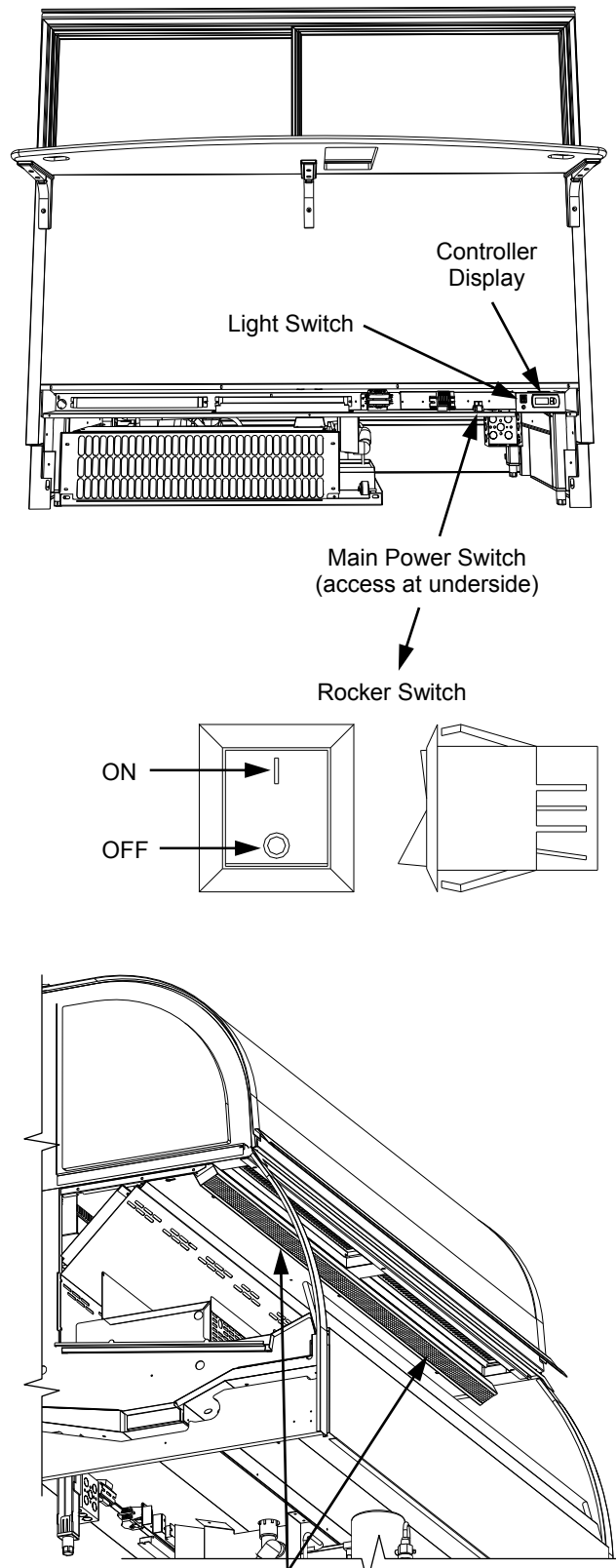

Honeycomb Air Diffuser. See **PREVENTIVE MAINTENANCE - HONEYCOMB AIR DIFFUSERS [SERVICE TECHNICIANS ONLY]** section in this manual for cleaning instructions.



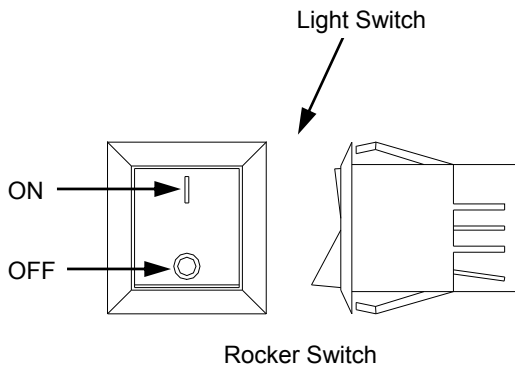
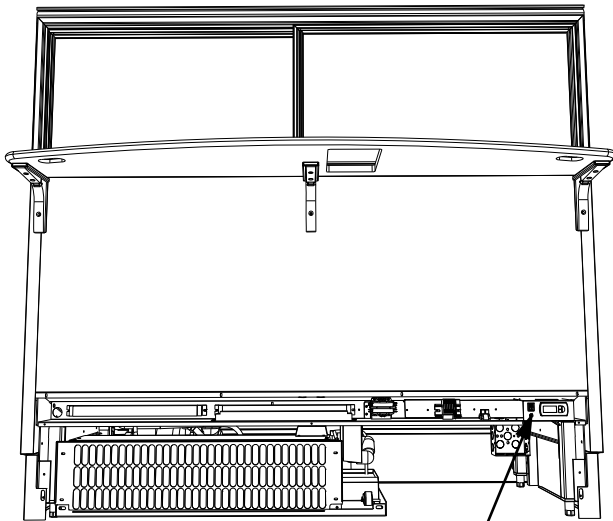

### 3. Fluorescent Light Guidelines

- Turn lights on. All of the lights should come on at the same time. First time lighting may require a short warm up period for the bulbs. Slightly dim or a flickering of new bulbs is normal. If lights do not turn on, check that all of the light plugs are in.

#### Removal of lamps:

- Grasp lamp firmly and carefully pull downward and out from socket.
- See photos at mid-right.

#### Installation of lamp:

- Align pins with slot.
- Insert pins into socket and push upward into place.
- See photos below.

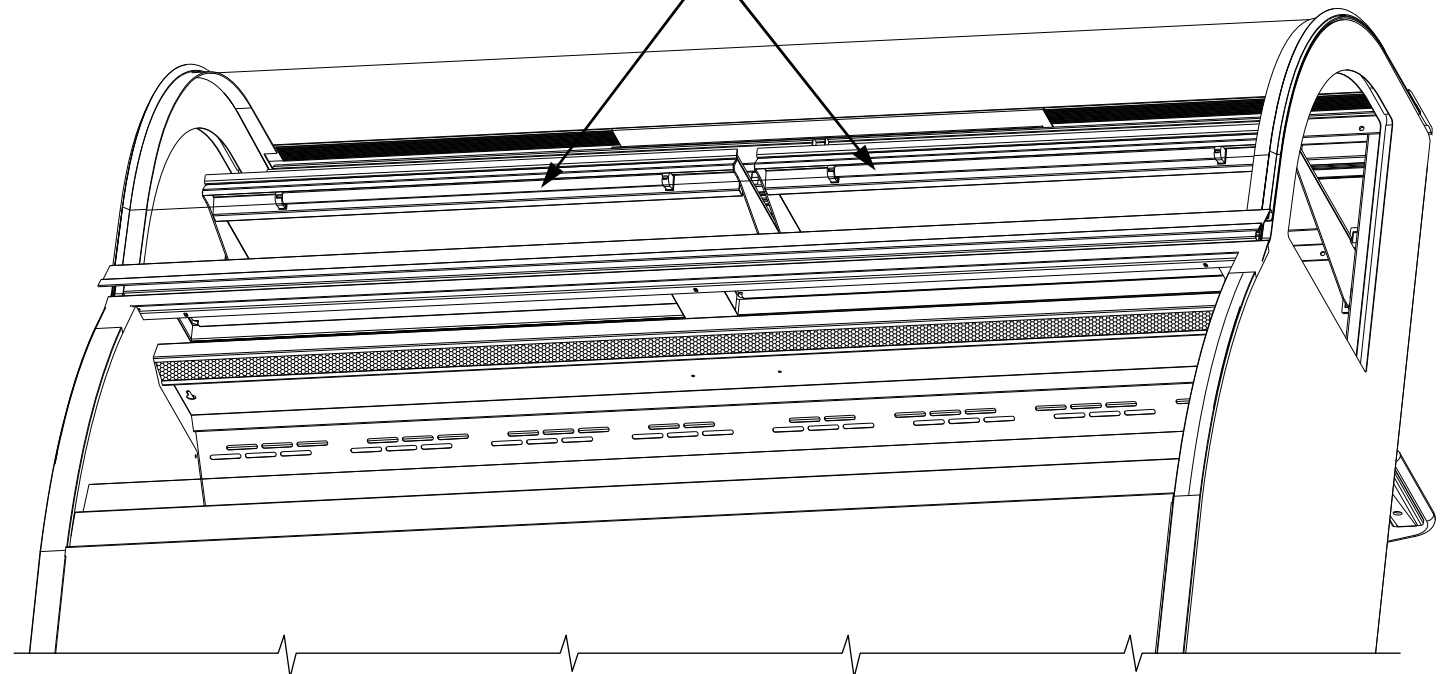

***Anti-Theft Grid Installation (Optional Item only on Model SB5766)***

- Position Anti-Theft Grid so that the locking rods extend down pointing towards the floor.
- Insert grid extensions into the forward air return louver.
- With “U” shackle released from the padlock base, insert the locking “U” of the padlocks through the stationary locking bracket.
- Rotate “U” shackle 90 degrees and pull up through grid; secure “U” shackle into padlock base.

**Note:** Due to possible design modification, actual Anti-Theft Grid construction and positioning may differ than depicted below.

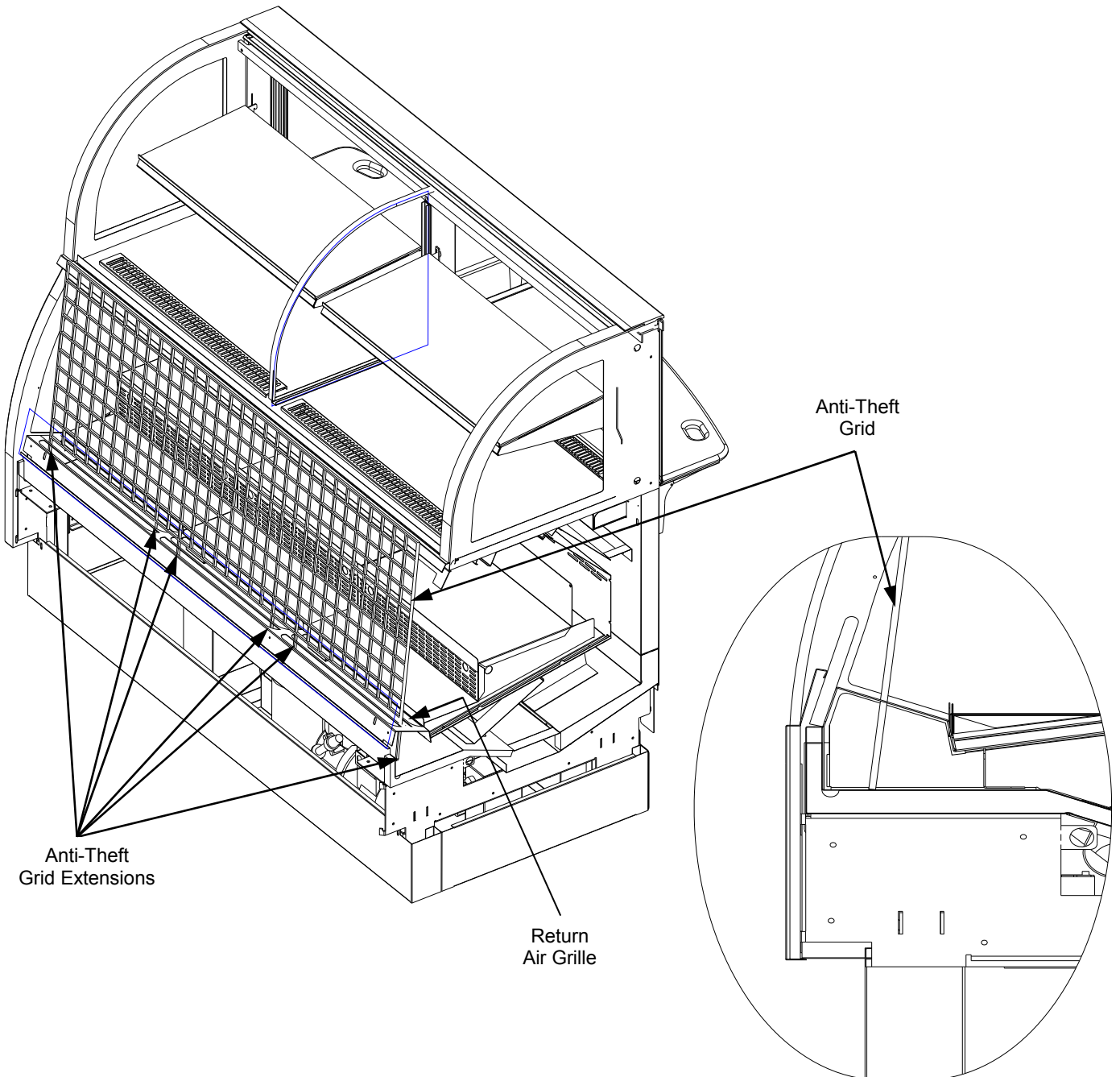



### **1. Crumb Tray**

- Located in back of case under ledge.
- Pull out to empty and clean. Replace promptly.
- Note: Make sure drawer is pushed in tight to maintain refrigeration efficiency.

### **2. Removing the Rear Doors**

- Move the rear doors toward the center of the case.
- Individually lift each door up into the upper door frame track at the top of the case.
- Pivot the bottom of the door out.
- Slip out of the upper door frame track.

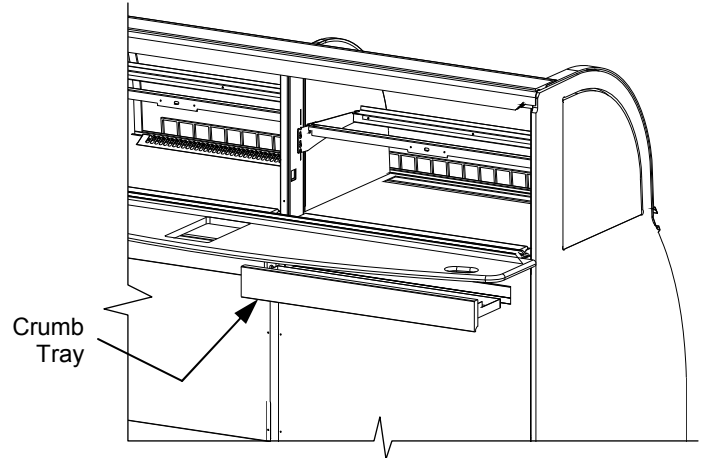

### **3. Installing Rear Doors**

- Doors are not interchangeable, and must be installed as labeled.
- **Note: Doors are labeled in the lower corners to identify their proximity to the interior of the case (inner or outer door).**
- Inner door must be installed first in the inner door track.
- Insure that the door pull handle is to the outside and to the left of the case.
- Insert the door into the upper inside track and lower door onto the inside lower track.
- Move inner door to the left.
- Install the outer door with the door pull handle to the right and the chrome door stop to the inside lower right.
- Insert the door into the upper and outer track and lower door onto the outer lower track.

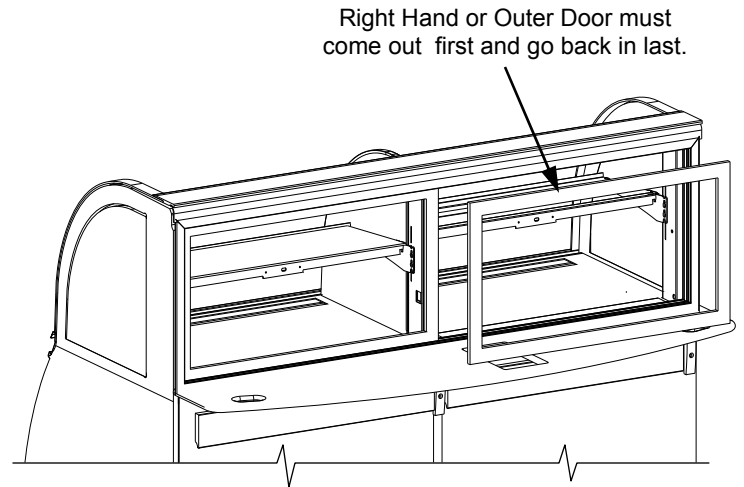

### **4. Removing Interior Shelving**

- Remove any product from the display area.
- Remove the ABS shelving.
- Turn off light switch prior to unplugging shelf light.
- Unplug shelf light.
- Remove the complete shelf assembly
  - Use even upward pressure to disengage the shelf assembly support brackets from the adjustment slots.

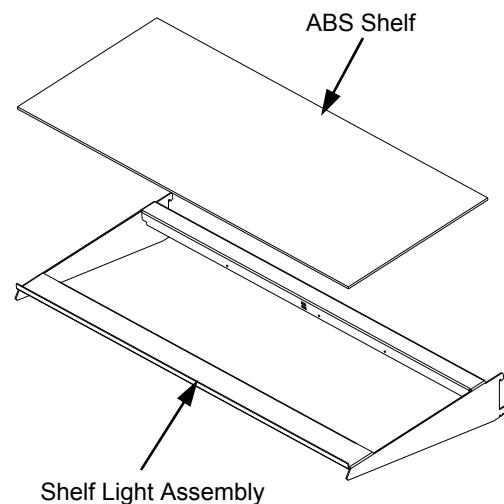

**5. Removing and Replacing Toe-Kicks Panels**

- *Front and rear kicks be removed first and installed last when performing maintenance.*

**6. Removing Front Toe-Kick**

Remove the two screws located on the upper front of the toe-kick at both ends.

**7. Removing rear Toe-Kick**

Remove four screws at both ends of the grille.

**8. Removing Side Toe-Kicks**

Note: Side toe kicks are captive by the rear kick panel in the back of the unit.

- Remove screws to the rear toe-kick.
- Remove front kick panel.
- Remove screws at front of side toe-kicks.

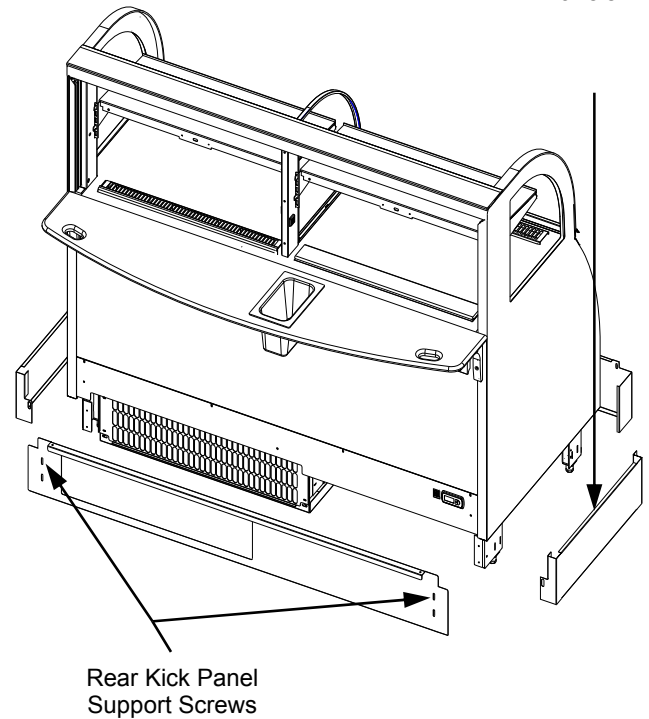
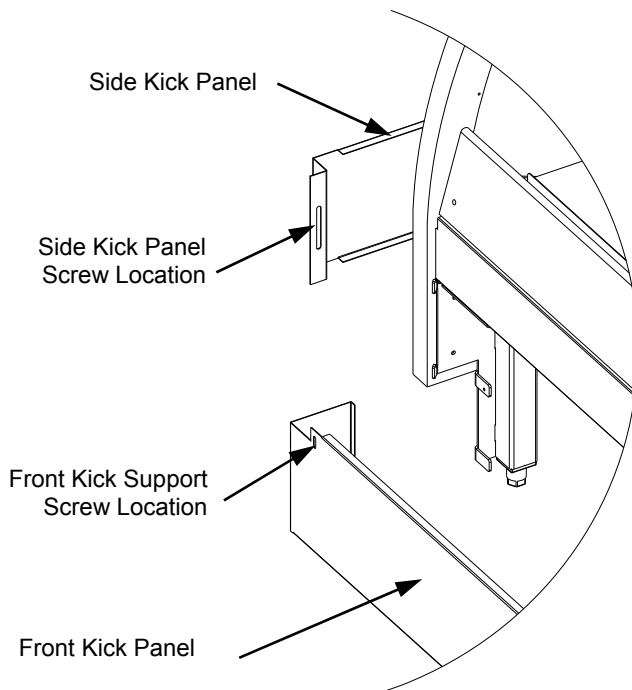
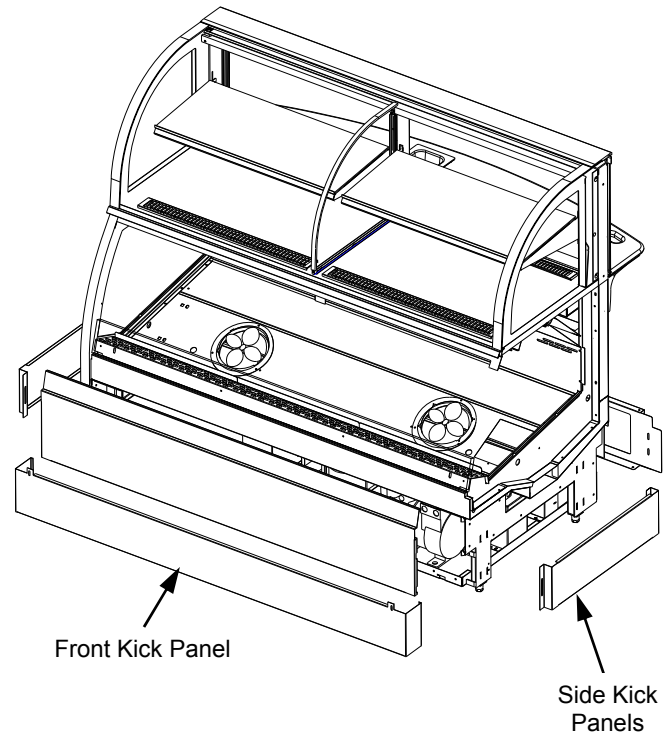

**9. Service Area, Ambient / Refrigerated**

- Note: Illustrations at right may not depict an exact representation of every particular unit.
- Access is through rear doors.
- Lift air baffle straight up then rotate 90 degrees so the arrows on the tag point down and tag is

to the rear of the case. Lower the baffle, with slots facing up, back down into the air channel.

- To close, reverse the procedure.
- Note: Removing the baffle facilitates cleaning interior by providing easy removal of refuse to the crumb tray.

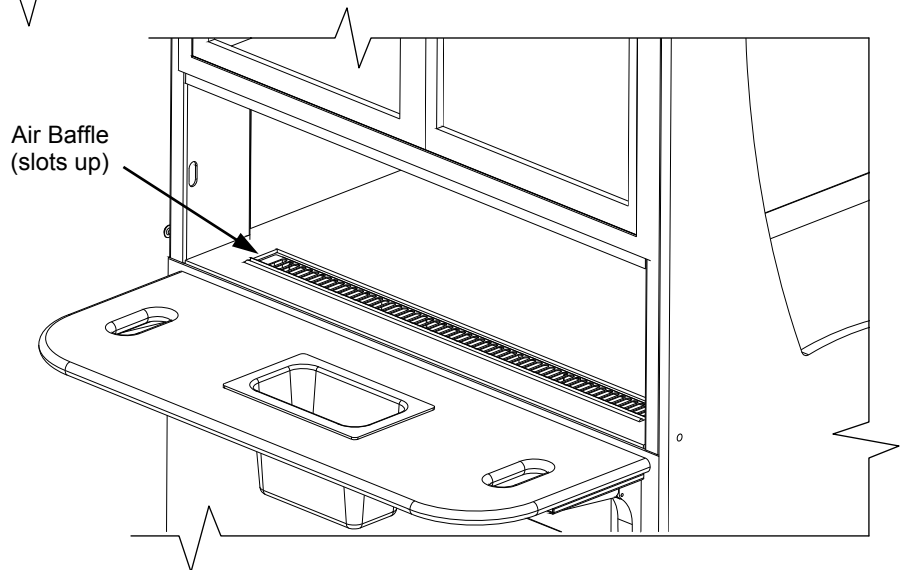
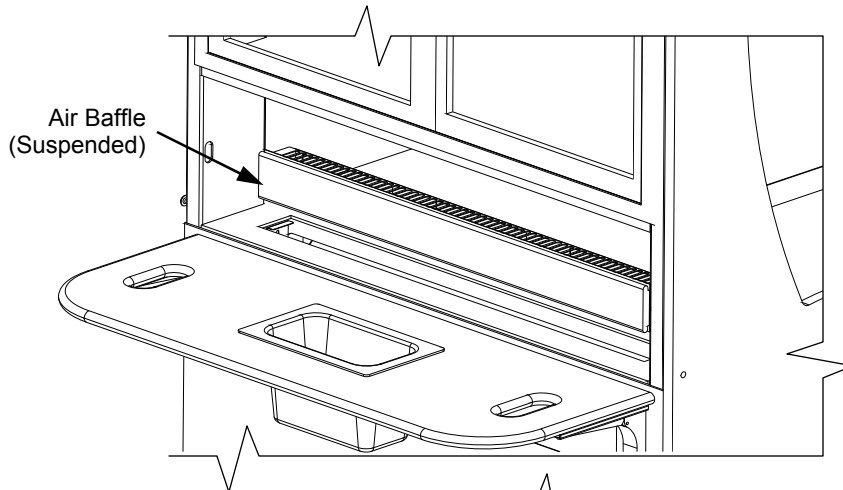
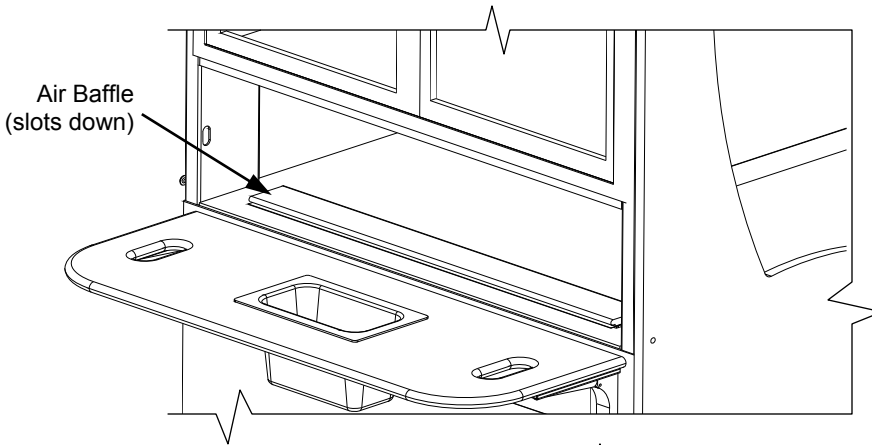

## **1. Electrical: Access and Connections**

Connections must be performed by a certified electrician.

**Warning! Disconnect power before providing maintenance and service to unit.**

## **2. Electrical Leads**

- Remove rear Toe-Kick panel.
- The electrical leads are located inside the 4 x 4 electrical box at the rear lower right hand base of the case.

## **3. Light Ballast Access**

- Remove 6 screws from rear wireway cover to access electrical connections and ballasts.

## **4. Evaporator Fans Access**

- Remove lower decking.
  - A finger hole is provided to lift up and pull out decking.

## **5. Removing Fan Assembly**

- Unplug the fans.
- Remove screws from the fan supports.
- Remove fan assembly from the shroud assembly.

## **6. Temperature & Defrost Control**

- The case temperature Set Point is set at the factory, as determined by the case size and sensor probe location.
- The temperature is controlled by a thermostat.
- If a temperature setting change is required, follow the Programming Steps in the Temperature Controller section of this operating manual.
- If service is required to the temperature control unit, call Structural Concepts. This maintenance should be performed by a certified technician.

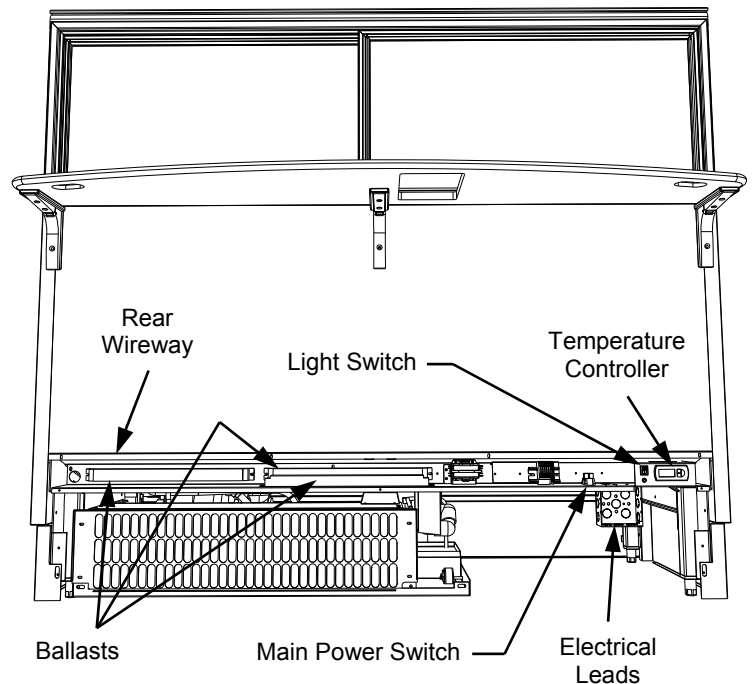
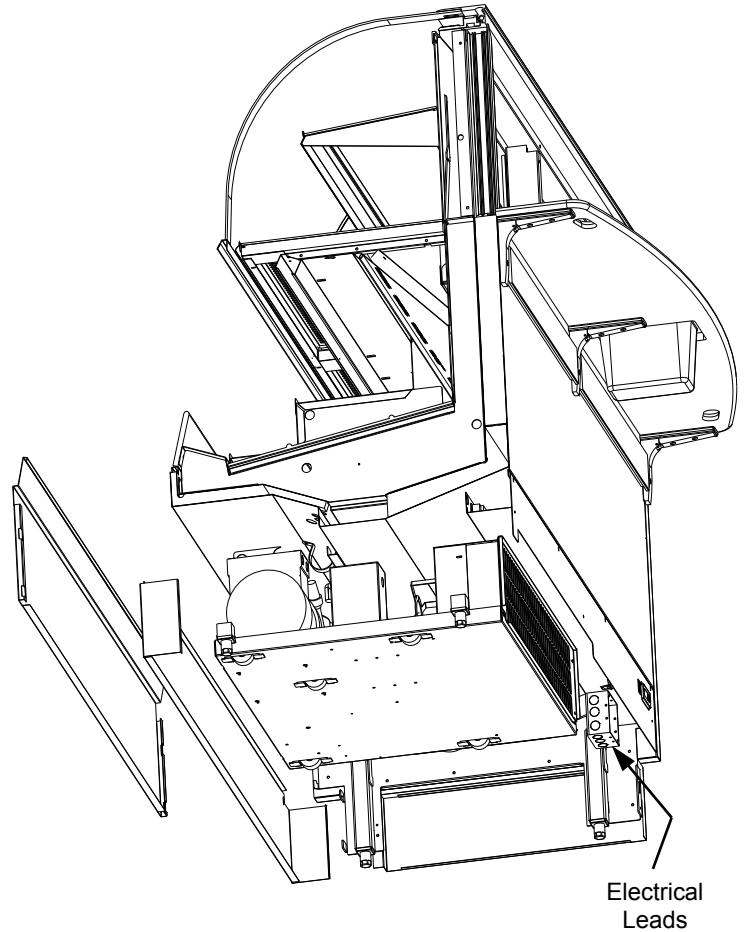

## REFRIGERATION FUNDAMENTALS

### **1. Refrigeration: Access, Connections & Removal**

Note: Rollers are mounted to the units base to facilitate in moving the condenser.

- Remove front panel. Lift panel from lower edge upward approximately a half inch.
- Remove front toe-kick.
  - Remove two screws located on the upper front of the toe-kick at both ends.
  - See Illustrated Parts Breakdown in this manual.

### **2. Assembly / Disassembly / Servicing To Be Accomplished By Licensed Refrigeration Contractor**

- Refrigerant lines are equipped with screw on/off fittings to facilitate maintenance.
- The control module has quick disconnect electrical fittings to the controller face.
- See Illustrated Parts Breakdown in this manual.

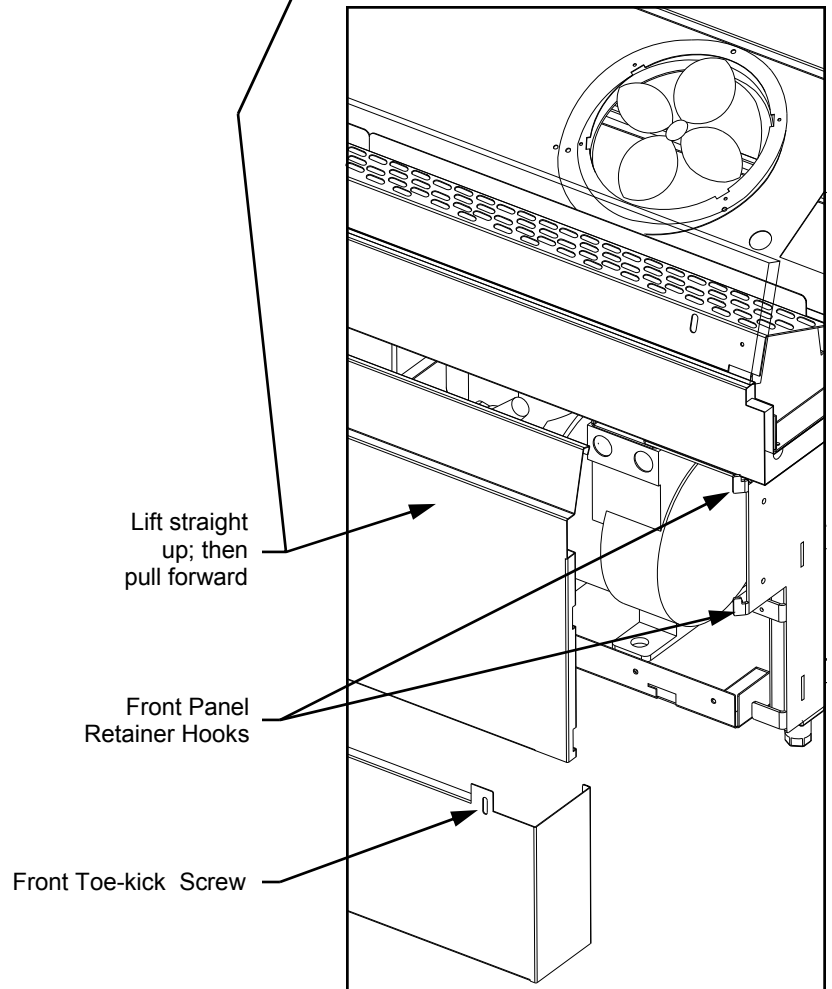
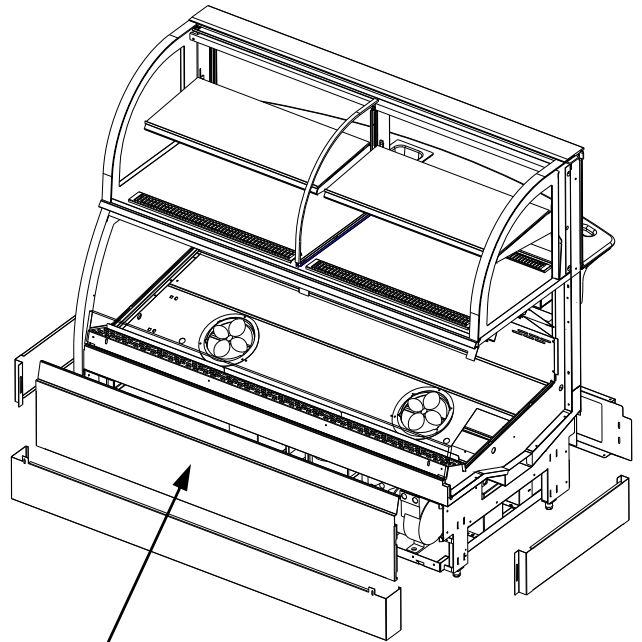

### 3. Expansion Valve Access

- The expansion valve is accessible from the front of the case.
- Remove lower decking using finger hole to lift up and pull out.
- The expansion valve (TXV) is located directly below the access panel.

### 4. Refrigeration Installation

- **Warning!** Avoid damage to condensate drain while inserting compressor package.
- Keep refrigeration unit to the right against the frame of case. Levelers may need to be adjusted for proper height clearance to fully insert unit.
- When pulling or pushing unit in or out under the case, use caution to avoid damage to copper refrigeration lines and hoses.

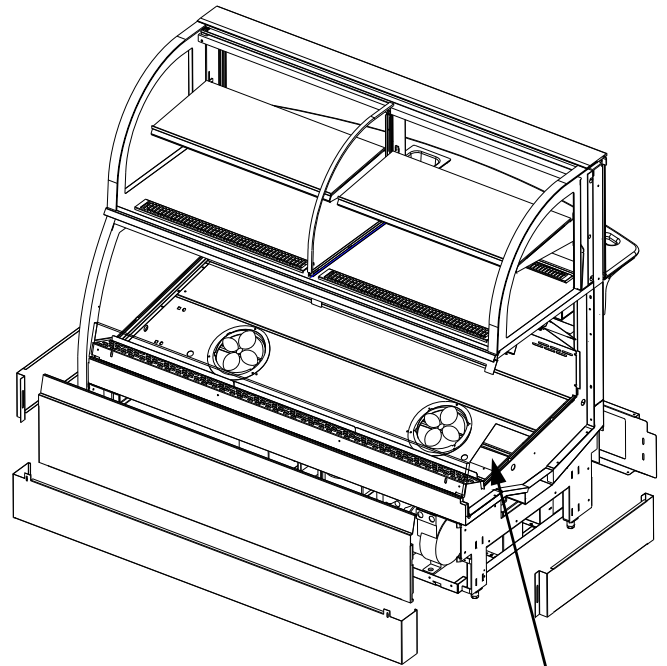

Expansion Valve Access Cover

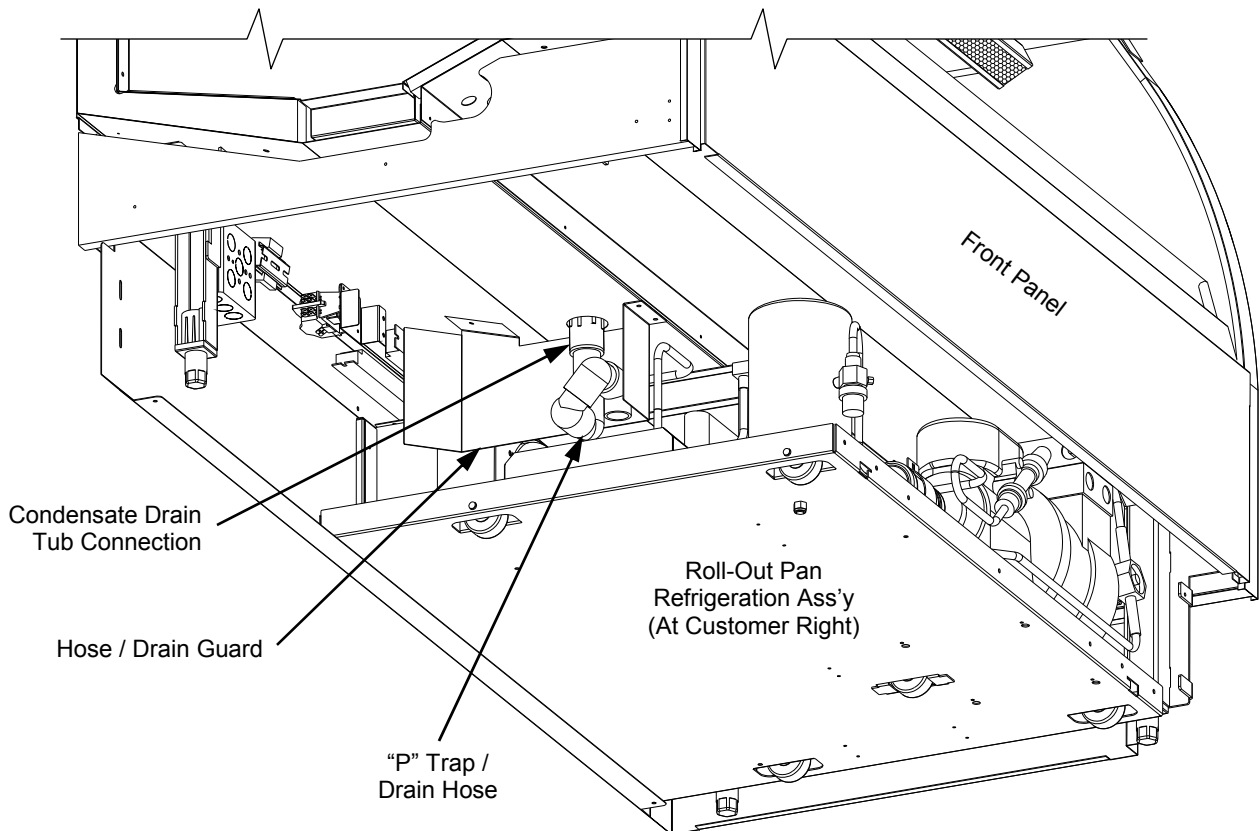



## HOT GAS CONDENSATE EVAPORATION SYSTEM

### **Hot Gas Condensate: Unit is provided with Hot Gas Condensate Removal System**

**Warning! Disconnect power before providing maintenance and service to unit.**

#### **1. System Operation**

- This system utilizes a hot gas serpentine coil that is routed through a condensate reservoir allowing water to be heated, in conjunction with a Wicking material that is partially submersed with warm condenser air passing through it for evaporation.
- The system also incorporates an overflow reservoir with heating element to ensure complete condensate removal.

#### **2. Indicator Light**

- Hot gas condensate removal system is also equipped with an Indicator Light (red) for Wicking Material replacement, accessible at rear of case. See picture below.

#### **3. Wicking Material Replacement**

- Pull condensing system out from under unit.
- Remove wicking material cover from top of condensing system by removing attaching screws. (see illustration above top-right)
- To obtain replacement Wicking Material go to [www.filters-now.com](http://www.filters-now.com) at (877) 991-0400 and order filter 'UFK01' or call Structural Concepts Corporation Technical Service at 1-(800)-433-9489 and order part # 83328.

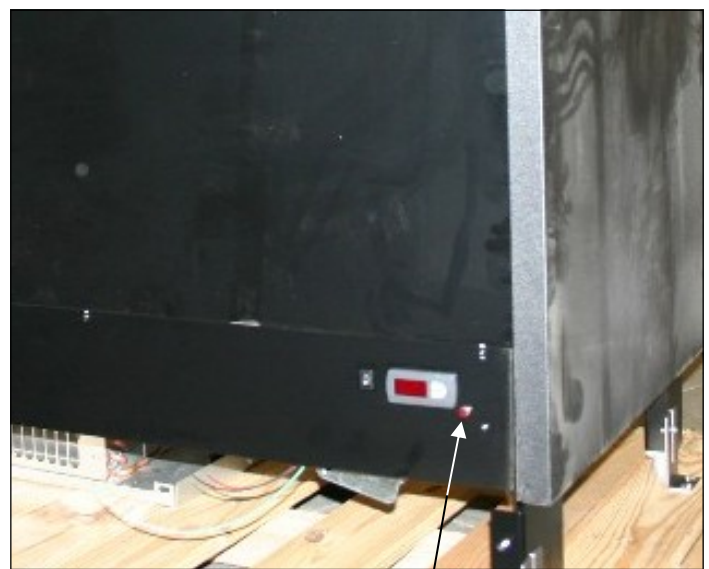
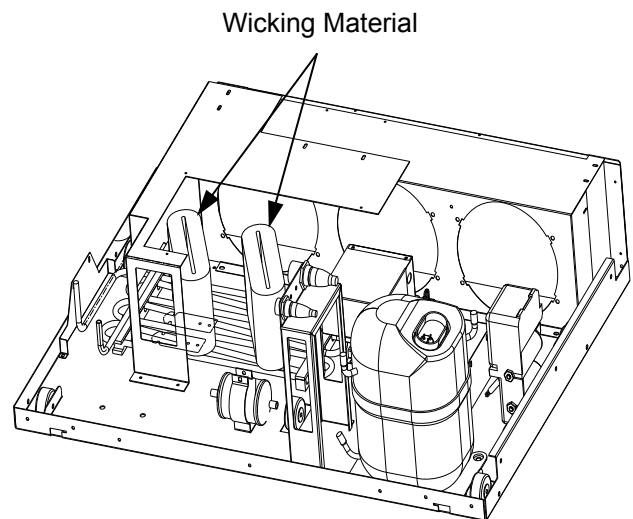
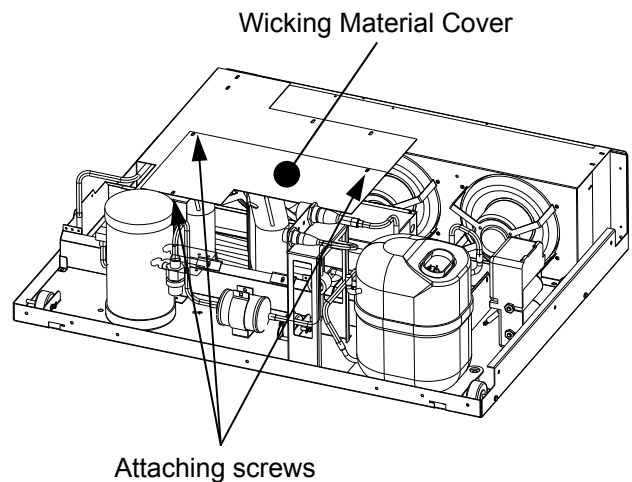

## LOAD LEVEL GUIDELINES [APPLICABLE TO ALL MODELS]

### Load Level Guidelines

**Caution! Do Not Block Airflow! If airflow is blocked by product, product temperatures will vary and possibly reach unsafe levels.**

> Illustration below displays product placement allowing proper air flow.

> Note: Illustration below may not reflect every feature or option of your case.

- Case Front: The dashed line in illustration below, reflects an “invisible curtain” of airflow from the “Honeycomb” Air Diffuser to the Return Air Grille. This area must not be blocked.
- Case Top: Product must be kept at least 1” below “Honeycomb” Air Diffuser.
- Case Rear: Do not allow the product to press up against the Rear Plenum. Keep at least 1” distance between product and Rear Plenum.

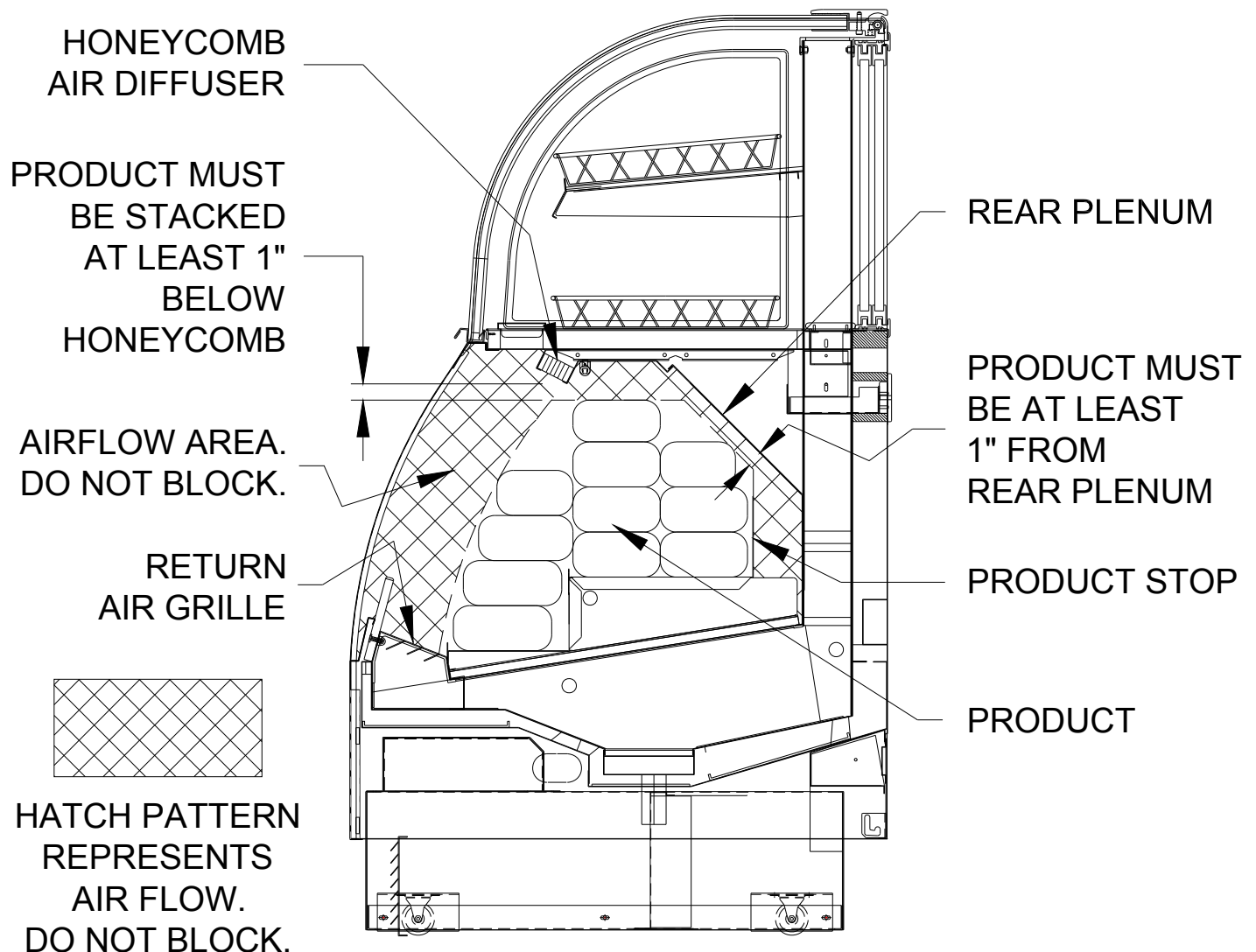

**Serial Label Location & Information Listed / Technical Information & Service**

- Serial labels are located near the electrical access on your case.
- Serial labels contain electrical, temperature & refrigeration information, as well as regulatory standards to which the case conforms.
- For additional technical information and service, see the *TECHNICAL SERVICE* page in this manual for instructions on contacting Structural Concepts' Technical Service Department.
- See images below for samples of both refrigerated and non-refrigerated serial labels.





888 E. Porter Rd · Muskegon, MI 49441

**ENCORE<sup>®</sup>** MODEL HV74RSS SCROLL  
SERIES SERIAL NO.

**FOR PARTS AND SERVICE**  
CALL 1-800-433-9489

**SAMPLE ONLY**

  3048256 CONFORMS TO UL STD 471 CONFORMS TO NSF STD 7 CERTIFIED TO CAN/CSA STD C22.2 NO 120	ELECTRICAL RATING REFRIGERANT DESIGN PRESSURE MINIMUM CIRCUIT MAXIMUM OVERCURRENT	120/1/60 24A R404A AMOUNT ?? OZ HIGH 450 LOW 200 30A 30A
---	---	--

**SAMPLE ONLY**

Super Heat Temp	8-10°F
BTUH Requirements	9,738 BTUH @ 20° F SST
Defrost	6 defrosts per day, 45° F termination, 45 min. failsafe

**SAMPLE ONLY**

----- Sample Serial Label For Refrigerated Case -----



888 E. Porter Rd · Muskegon, MI 49441

**Addenda<sup>®</sup>** PC5682 txtRemote  
txtSerialNumber

120 VOLTS 60 HZ SINGLE PHASE 1.84AMP

**FOR PARTS OR SERVICE CALL**  
**STRUCTURAL CONCEPTS**  
AT  
1-800-433-9489

**SAMPLE ONLY**

 3048256 CONFORMS TO UL STD 65 CERTIFIED TO CAN/CSA STD C22.2 NO 120	N/A
---	-----

----- Sample Serial Label For Non-Refrigerated Case -----

ILLUSTRATED PARTS BREAKDOWN FOR MODEL SB5766.3923/3923A (SIMILAR TO OTHER MODELS)

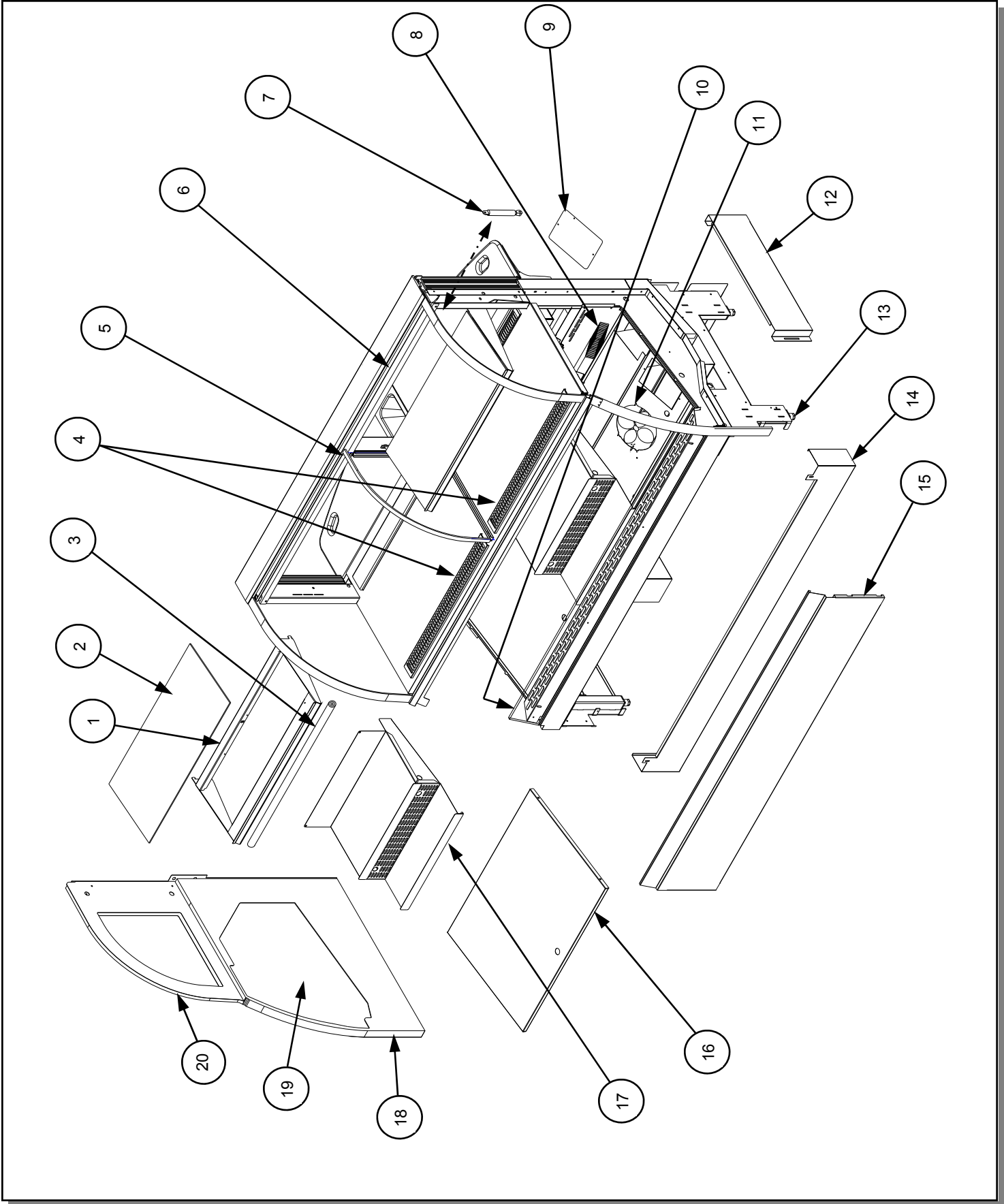

ILLUSTRATED PARTS BREAKDOWN FOR MODEL SB5766.3923/3923A (SIMILAR TO OTHER MODELS)

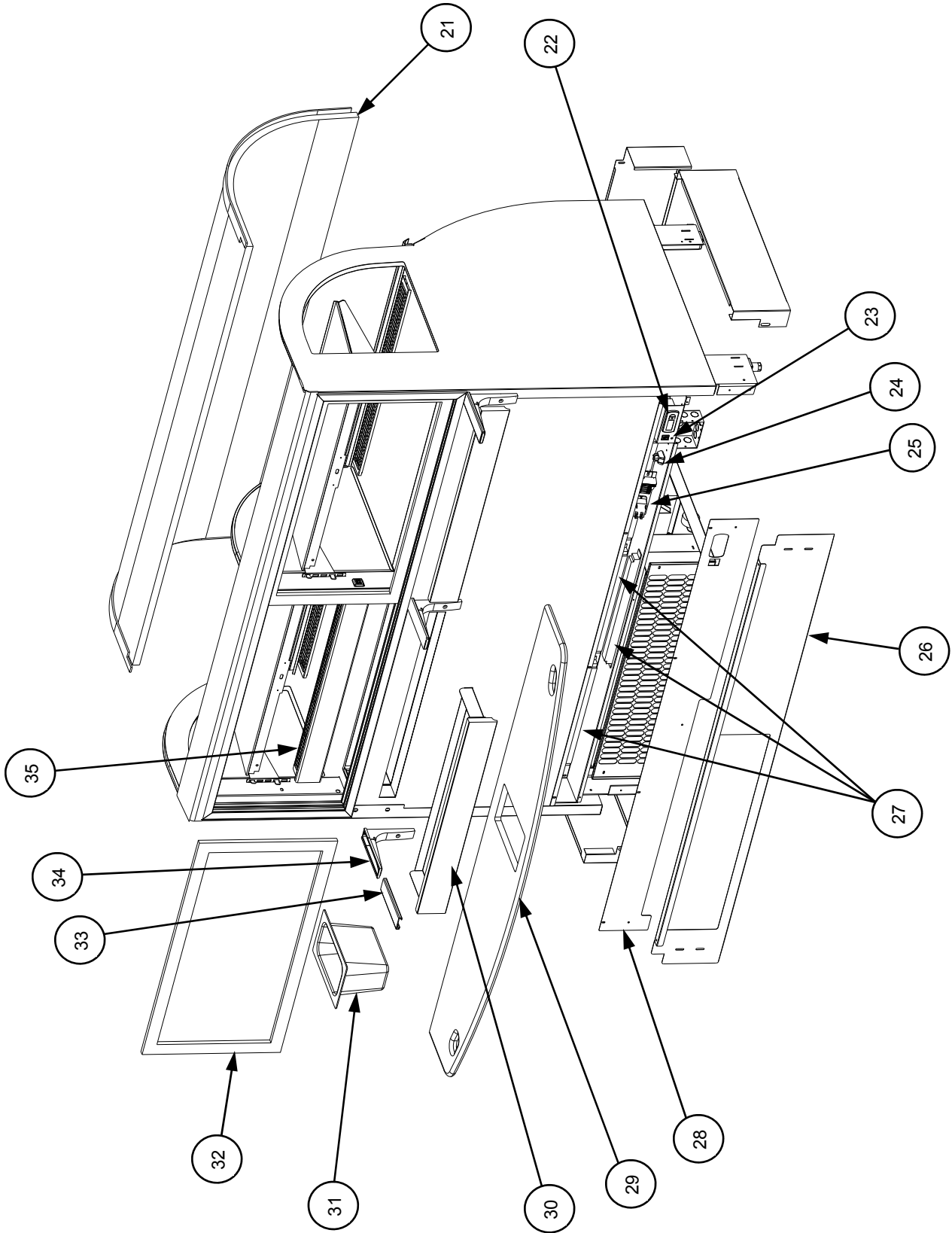

**ILLUSTRATED PARTS BREAKDOWN FOR MODEL SB5766.3923/3923A (SIMILAR TO OTHER MODELS)**

**NOTE: MODEL SB5754.3924  
CONDENSER PACKAGE  
IS SIMILAR TO  
ILLUSTRATION SHOWN**

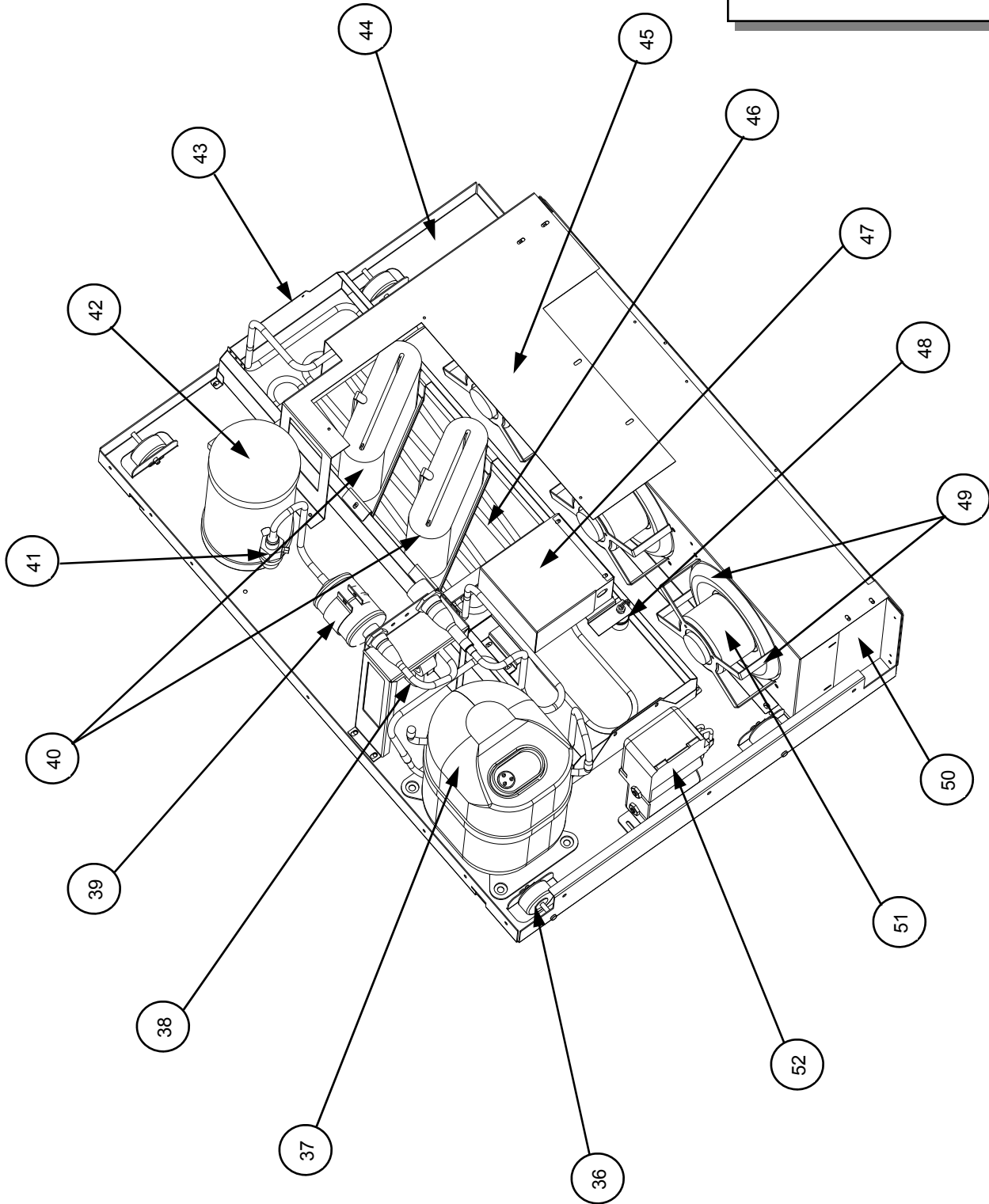



**PARTS LIST FOR MODEL SB5766.3923/3923A (SIMILAR TO OTHER MODELS)**

1	Rack Light Assembly LH or RH	30	Crumb Tray
2	Upper ABS Shelving	31	Condiment Pan
3	Bulb	32	Rear (Pike) Door, Left or Right Hand Specific
4	Front Air Return	33	Ledge Support Bracket Channel
5	Center Glass Divider	34	Ledge Support Bracket
6	Clam Shell Assembly	35	Baffle Assembly
7	Front Door Assist Gas Cylinder	36	Caster, Refrigeration Assy., Roll Out Pan
8	Honeycomb	37	Embraco® Hermetic Compressor
9	Expansion Valve Access Plate	38	Sight Glass
10	Acrylic Front Air Deflector	39	Filter Drier
11	Fan Motor / Blade / Bracket Assembly	40	Evaporative Wicking Material
12	Side Kick Panel	41	Service Valve, Receiver
13	Leveler	42	Receiver
14	Front Kick Panel	43	Hot Gas Pan
15	Front Panel	44	Roll Out Pan, Refrigeration Assembly
16	Deck Pan	45	Support, Refrigeration Close Off
17	Step Insert	46	Hot Gas Loop
18	Lower End Panel Assembly	47	Electrical Box - Hot Gas Overflow
19	Mirror, Stainless Steel	48	Liquid Level Control
20	Upper End Panel Assembly	49	Fan Blades / Bracket
21	Front Curved Insulated Glass Assembly	50	Condenser Coil
22	Controller Display, Temperature	51	Fan Motor
23	Indicator Light, Hot Pan	52	Electrical Box - Compressor
24	Rocker Switch, Main Power (accessible at underside)	53	
25	Contactator	54	
26	Toe-Kick, Rear	55	
27	Ballasts	56	
28	Cover, Rear Wireway	57	
29	Rear Ledge	58	

**ILLUSTRATED PARTS BREAKDOWN / PARTS LIST FOR MODEL SB5735 CONDENSER PACKAGE**

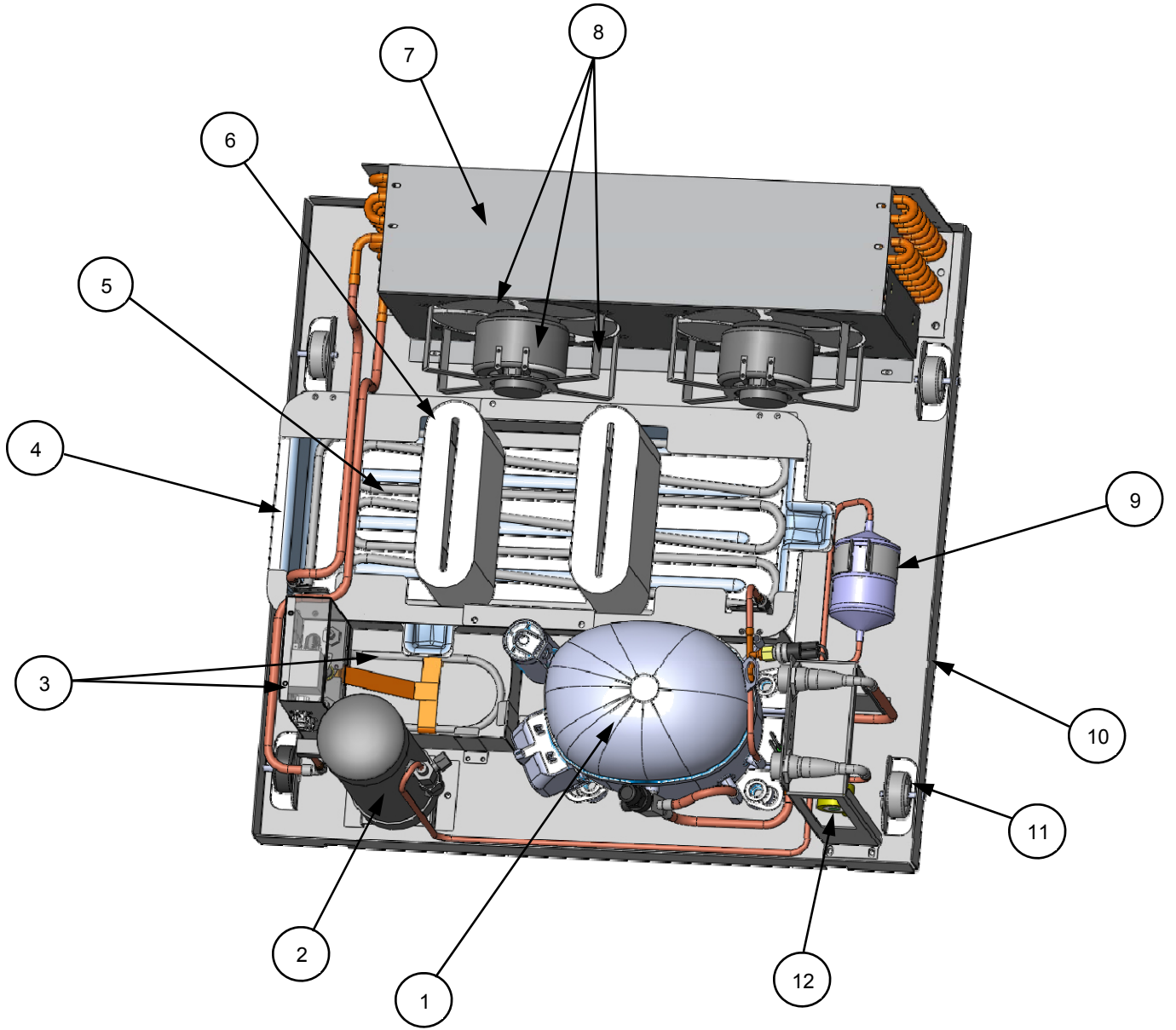

1	Embraco® Hermetic Compressor	8	Fan, Fan Shroud, Fan Blades
2	Receiver	9	Filter Drier
3	Electrical Box - Hot Gas Overflow	10	Roll Out Pan, Condenser Unit
4	Condensate Pan	11	Caster, For Condenser Unit Pan
5	Hot Gas Loop Condensate System	12	Sight Glass
6	Evaporative Wicking Material	13	
7	Condensing Coil Shroud	14	

**CLEANING SCHEDULE [TO BE PERFORMED BY STORE PERSONNEL]**

**WARNING! TURN OFF POWER TO CASE BEFORE PERFORMING PREVENTIVE MAINTENANCE!**

Cleaning	Frequency	Instructions
Case Exterior	Daily	<b>Glass / Mirrors:</b> Clean front glass, glass shelves, and mirrors with a household or commercial glass cleaner.
	Daily	<b>Acrylic:</b> Clean with a warm water and mild soap solution and soft cloth. Never use ammonia-based cleaners on acrylic.
	Daily To Weekly	<b>Magnetized Condenser Coil Filter:</b> Vacuum or brush with soft-bristled filter. To remove grease and grime build-up, remove from case. Submerge in warm water and soap solution. Rinse. Dry. Return to case. See Illustration #1 below.
	Weekly	<b>Condensing Coil:</b> Remove base panel and condensing coil cover [#2 and #3 below]. Vacuum or brush condenser coil [#4 below] with metal or fiber brush to remove dust and dirt. Be careful to avoid damaging coil fins while cleaning!
	Weekly	<b>Rear Sliding Doors and Door Track:</b> Remove rear doors. Clean w/household or commercial cleaner. Clean out door track with moist cloth. See #5 below].
Case Interior	Daily	<b>Baffle:</b> Remove from case. Submerge in warm water and soap solution. Clean with soft-bristled brush. See B - C - D below.
	Weekly	<b>Deck Underside:</b> After removal, vacuum debris under decking.
	Weekly	<b>Crumb Drawer:</b> Pull out and empty. Clean with moist cloth. See #A - B below.
	Monthly	<b>Decks &amp; Inserts:</b> Clean with mild soap, water & soft cloth.
	Monthly	<b>Drain:</b> Remove drain access door on fan panel. Clean drain with warm water and mild soap solution. Remove any debris that may clog drain.

A. Baffle (preventing refrigeration) & Crumb Tray (shown not pulled out)



B. Baffle (out of case) & Crumb Tray (pulled out)



5. Rear Sliding Doors / Track

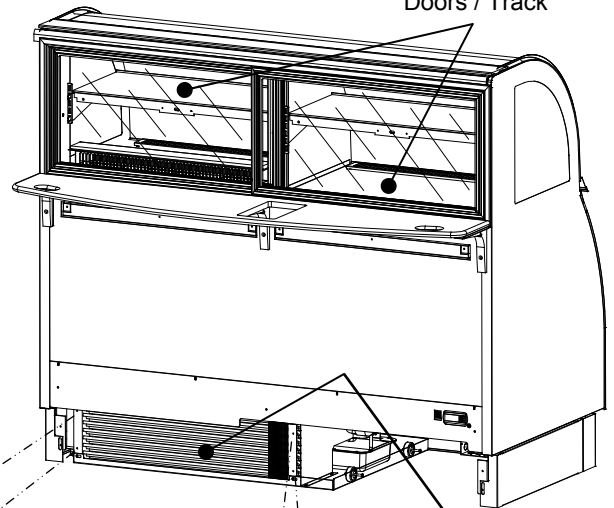

4. Condensing Coil

C. Instructions on Baffle



Image #D Baffle (refrigerating compartment) & Crumb Tray (not pulled out)



1. Magnetized Condenser Coil Filter

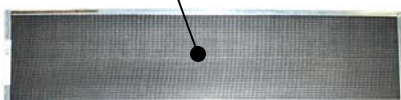

2. Base Panel

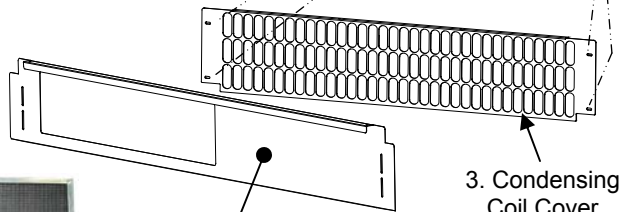

3. Condensing Coil Cover

**CLEANING SCHEDULE [TO BE PERFORMED BY TRAINED SERVICE PROVIDERS ONLY]**

**WARNING! TURN OFF POWER TO CASE BEFORE PERFORMING PREVENTIVE MAINTENANCE!**

Maintenance	Freq.	Instructions
Case Exterior	Qtly	<b>Condensing Coil:</b> Using air pressure or an industrial strength vacuum, clean the dust and dirt that may collect on the condenser coil. It may be necessary to use a soft-bristled brush to loosen up caked dust and debris that may form on coil. <ul style="list-style-type: none"> <li>See previous page for step-by-step illustrations on accessing condensing coil.</li> </ul>
	Qtly	<b>Under Case Cleaning:</b> Once refrigeration package is clear of unit, vacuum under case to remove all dust and dirt that may collect.
Case Interior	Qtly	<b>Tub, Coil and Drain:</b> Remove evaporator fan panel [as shown in images #6 and 7 below] and clean tub, coil and drain with warm water and mild soap solution. Remove any debris that may clog drain.
		<b>Compressor Area:</b> Slide out from case. Wipe off dust & debris w/moist cloth.
		<b>Hot Gas Loop Condensate Pan:</b> Disconnect power. Slide out refrigeration assembly (casters provided for easy slide). Use a de-scaling solution (such as CLR® that will prevent corrosion, lime and rust) to thoroughly clean pan. Use wet / dry vacuum to remove all residue. If necessary, wipe down with damp cloth.
	Qtly	<b>Evaporative Wicking Material:</b> Lift up and off from support. Replace with new evaporative wicking material.
	Qtly	<b>Fan Blades, Shroud, Drain:</b> Wipe down each blade and shroud with moist cloth. Clean out drain. See images #6 and 7 below.
	Qtly	<b>Honeycomb:</b> See <i>PREVENTIVE MAINTENANCE - HONEYCOMB AIR DIFFUSERS [SERVICE TECHNICIANS ONLY]</i> section in this manual for specs.
	Qtly	<b>Upper and Lower Step Inserts:</b> Remove from Case. Clean w/soap and water.

Image #6  
Use finger holes to lift up Deck. Remove from case.



Image #7  
Clean under Air Return Grille and Fan Shroud Area with moist cloth. Remove drain cleaning access door and clean drain.



<b>Product is Drying Out</b>	Check the relative humidity in the store.
<b>Water on the Floor</b>	Check that the drain is correctly positioned over condensate pan.
	Check that condensate overflow pan is plugged in.
<b>Excessive Fan Noise</b>	Check that the case is aligned, level and plumb.
<b>System is not Operating</b>	Check that the utility power is on.
	Check that the MAIN power switch is on.
	Check the circuit breaker box for tripped circuits.
<b>Digital Control Display is Blank</b>	Check that the MAIN power switch is on.
	Check the circuit breaker box for tripped circuits.
<b>Fans Not Working</b>	Check that the MAIN power switch is on.
<b>Case Lights Not Working</b>	Check that <b>ALL</b> of the lights are plugged in.
	Check bulbs for proper installation and connection.
	Check for burned out bulbs.
	Clean dirt and dust from the bulbs to prevent flickering.
	Check that light switch is in the <i>on</i> position.

**Note: If problems persist call Starbucks® FASQ Desk.**

<b>Controller Display Flashing</b>	If display is flashing, refer to Carel® Temperature Controller Section in this manual.
<b>Not Holding Temperature</b>	If a large amount of warm product was added to the case, it will take time for the temperature to adjust. Unit needs pre-chilled product.
	The temperature will change during defrost cycle but will return to normal when compressor turns on.
	Check to see if the condenser coil has been cleaned.
	Check that the case is not in the sun or near a heat or air-conditioning vent.
	Check <i>air</i> grilles for obstruction and remove.
	Ensure that front air grilles are not obstructed by product or other décor.
	<b><i>Note: Product displayed on Front Air Grilles will cause case to run warm and will negate warranty.</i></b>
<b>Condensing Unit Not Operating</b>	Check that the main power switch is turned on.
	Check if the case is on and the control display is blank. If blank, call Starbucks FASQ Desk
	Controller may be in defrost mode. Compressor cycling on and off is a normal condition. Carel® Temperature Controller Section in this manual.

**Note: If problems persist call Starbucks® FASQ Desk.**



CONDITION	TROUBLESHOOTING
<b>Case Not Lining Up</b>	See Installation Section for instructions on properly aligning case (alongside other cases) and adjusting levelers.
<b>Water Is On The Floor</b>	<p><b>Caution!</b> Water on flooring can cause much damage! Until cause is determined (and repaired), follow these procedures:</p> <ul style="list-style-type: none"> <li>• Use wet-dry vacuum (or mop &amp; bucket) to remove standing water.</li> <li>• Use 'catch pans' for water to drain into. Swap out regularly until case has completely drained.</li> </ul>
	Check that the drain trap is free of debris.
	Check that the drain hose is correctly positioned over condensate pan (or floor drain, for remote units).
	Check store conditions. To prevent condensation in NSF® Type 1 environments, maximum conditions are to be 55% humidity / 75° Fahrenheit. For NSF® Type 2, maximum conditions are to be 60% humidity / 80° Fahrenheit. See serial label (at case rear near main power switch) for NSF® Type of your case.
	Check that evaporator pan is properly plugged in or connected.
	<p><b>Caution!</b> Disruption of power can cause water to overflow pan and seep onto flooring causing damage! Check that power to case is constant. Until power is restored, follow these procedures:</p> <ul style="list-style-type: none"> <li>• Use wet-dry vacuum (or mop &amp; bucket) to remove standing water.</li> <li>• Use 'catch pans' for water to drainage. Swap out regularly until evaporation of case is complete (or until power is restored).</li> <li>• When power to case is restored, evaporator pan should function properly and water will no longer overflow onto flooring.</li> </ul>
	<p><b>Caution!</b> Wicking material (if any on your particular hot gas loop system) may be dirty or worn and need replacement.</p> <ul style="list-style-type: none"> <li>• Slide refrigeration system out from under unit.</li> <li>• After refrigeration system has been carefully slid out from under unit, replace wicking material with new. If wicking material is not available, contact Structural Concepts®. See toll-free number at last page of this operating manual.</li> </ul>

CONDITION	TROUBLESHOOTING
<b>Fan Emits Excessive Noise</b>	Check that the case is aligned, level and plumb.
	Check evaporator fan for cleanliness.
	Unplug/power off fan motors. Check motor shaft for bearing wear.
	Check that fan motors are securely mounted in brackets.
	Verify that fan blades are securely mounted to fan motor.
	Check that nothing is preventing blade rotation.
	Check that the fan shroud is properly secured.
<b>Fans Are Not Working</b>	Check that the MAIN power switch is on.
	Check that fans are plugged in at the fan shroud.
	Check for foreign material obstructing fan performance.
	Check that fan blades freely rotate within fan shrouds
	Check that power is going to fans
	Check that fan wiring is connected on terminal blocks.
<b>Digital Control Display Is Blank</b>	Check that the MAIN power switch is on.
	Check the circuit breaker box for tripped circuits.
<b>System Not Operating</b>	Check that the utility power is on.
	Check that the MAIN power switch is on.
	Check the circuit breaker box for tripped circuits.

CONDITION	TROUBLESHOOTING
<b>Case Lights Are Not Working</b>	Check that light switch is in the <i>on</i> position.
	Check that <b>ALL</b> of the light cords and plugs are properly connected. See <b>MAINTENANCE - LIGHT FIXTURES (LED LIGHT FIXTURES)</b> section.
	Service Technicians Only: Check voltage at LED drivers. If voltage is entering but not exiting, LED driver may be faulty.
<b>Control Display Is Flashing</b>	See your case's serial label for your model's specified settings. See <b>SERIAL LABEL LOCATION &amp; INFORMATION LISTED / TECH INFO &amp; SERVICE</b> for label location, etc.
<b>Case Is Not Holding Temperature</b>	If a large amount of warm product was added to the case, it will take time for the temperature to adjust. Unit needs product to be pre-chilled.
	Temperature changes during defrost mode but will return to normal. Fourth LED will indicate defrost cycle in progress.
	Check that case is not in sun or near a heat or air-conditioning vent. See <b>OVERVIEW AND WARNINGS</b> section in manual for adverse conditions/spacing issue parameters.
	If case is located near front doors, temperature fluctuation can hinder unit's ability to maintain temperature. See <b>OVERVIEW AND WARNINGS</b> section in manual for adverse conditions/spacing issue parameters.
	Check that condenser coil air filter (attached to rear grille) has been cleaned. See <b>GENERAL CLEANING [TO BE PERFORMED BY STORE PERSONNEL]</b> section in operating manual for instructions.
	Check that condenser coil has been cleaned.
	Check air return grilles for obstructions.
	Check sight glass for flashing and/or low charge.
	Check Set Point Temperature; it may be adjusted too high.
<b>Condensing Unit Is Not Operating</b>	Check that the power is turned on.
	Determine if temperature controller settings are properly set. See your case's serial label for your model's specified settings. See <b>SERIAL LABEL LOCATION &amp; INFORMATION LISTED / TECH INFO &amp; SERVICE</b> section in manual for label location, etc.

**TROUBLESHOOTING [BY TRAINED SERVICE PROVIDERS ONLY] - CONDENSING SYSTEM**

CONDITION	TROUBLESHOOTING
<b>Head Pressure Too High</b>	Check that the Condensing Coil is not dirty or covered.
	Check that Condensing Fans are working.
	Check that refrigerant is not overcharged.
	Check to verify that a non-condensable is not in the system.
	Check that Liquid Line Drier is not plugged.
	Check that there are no close-offs around Condensing Coil.
	Check Set Point Temp.; it may be adjusted too high.
	Check System Operating Temperatures.
	Check that Store Ambient Temperature isn't above maximum allowed. See <i>Overview and Warnings</i> Section.
<b>Head Pressure Too Low</b>	Check that Refrigerant Charge isn't too low.
	Check that Suction Pressure isn't too low.
	Check to verify that Compressor Valves aren't bad.

**TROUBLESHOOTING [BY TRAINED SERVICE PROVIDERS ONLY] - EVAPORATOR SYSTEM**

<b>CONDITION</b>	<b>TROUBLESHOOTING</b>
<b>Low Suction Pressure</b>	Check that the Refrigerant doesn't have a low charge.
	Check that Expansion Valve (TXV Valve) isn't restricted.
	Check that Liquid Line or Filter isn't restricted.
	Check that Evaporator Motors are working.
	Check that High Superheat doesn't need adjusting.
	Check that the Thermostatic Element charge isn't depleted.
	Check that there is air no seepage of air around Condensing Coil.
	Check that the Coil is not iced up.
<b>High Suction Pressure</b>	Check that Refrigerant Charge isn't too high.
	Check that Compressor Valves aren't bad.
	Check that the Cooling Load isn't high.
	Check that Superheat Adjustment isn't low.
	Check TXV Bulb Installation a. Poor thermal contact. b. Warm location.
	Check Compressor: Low capacity means it is undersized for its application.

### Honeycomb Air Diffuser Removal

See **PREVENTIVE MAINTENANCE (TO BE PERFORMED BY TRAINED SERVICE PROVIDER)** section in this manual for cleaning frequency.

A. Wedge a non-metallic device of suitable strength (such as a ballpoint pen) between the honeycomb and the end panel.

**Caution!** Use care not to dislodge the heating wire (that prevents condensation on the lamp assembly).

B. Apply pressure to collapse the honeycomb to allow it to be pulled out of honeycomb retainer.

C. Carefully pry downward and away from the honeycomb retainer. Remove entirely from case.

Clean honeycomb with warm water and soap solution. Submerge if necessary. Use brush to dislodge stubborn or sticky residue. Dry by using vacuum's blow mode (vs. suction mode).

### Honeycomb Air Diffuser Installation

D. Squeeze honeycomb to allow it to fit into the honeycomb retainer.

E. Carefully slide honeycomb into place.

F. Adjust honeycomb so that it fits flat against retainer. It must not be wavy or out of position.

**Note:** For honeycomb air diffusers in other

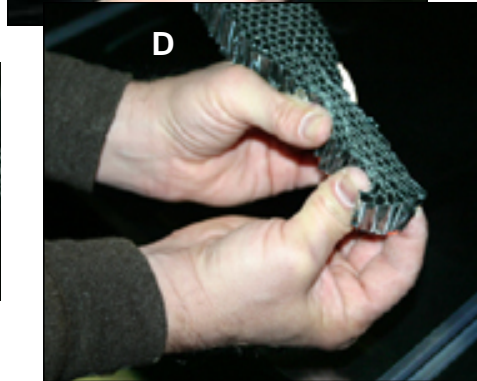
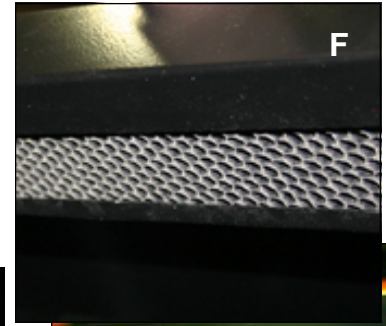

View of Case Honeycomb Air Diffuser

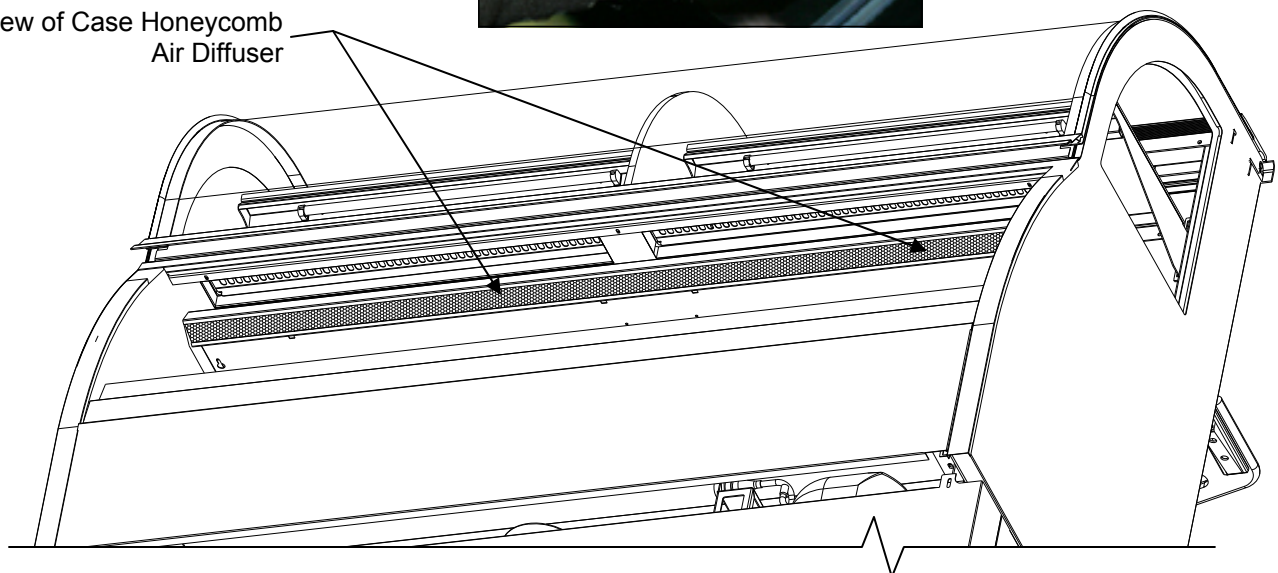

# CAREL

## ir33 platform

Integrated Electronic  
Microprocessor Controller



### Programming The Instrument

#### To Modify The Setpoint

**Set** 1. Press and hold the "SET" key for at least 1 second.

**▲/aux** **def/▼** 2. Use arrow keys ▲ ▼ on temperature controller to increase (or decrease) the setpoint.

**Set** 3. Quickly press and release the "SET" key again.

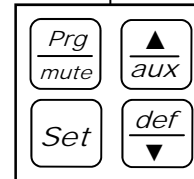

#### To Modify Defrost, Differential, Other Parameters

**Prg/mute** **Set** 1. Press & hold "Prg" & "SET" keys together for five (5) seconds; display will flash "0", representing password prompt.

**Set** 2. Confirm by pressing "SET" key.

**▲/aux** **def/▼** 3. Press ▲ or ▼ to reach the category to be modified.

**Set** 4. Press "SET" to modify this selected parameter.

**▲/aux** **def/▼** 5. Increase or decrease the value using the ▲ or ▼ button respectively.

**Set** 6. Press the "SET" key to temporarily save the new value and return to the display of the parameter.

**Prg/mute** 7. Press & hold the "Prg" key for at least 5 seconds to save changes. This action will also mute the audible alarm (buzzer) & deactivate the alarm relay.

#### How To Change Reading From Fahrenheit (°F) To Celsius (°C)

**Prg/mute** **Set** 1. Press and hold "Prg" and "SET" keys together for at least 5 seconds; display will show "0" (password prompt).

**Set** 2. Confirm by pressing "SET" key.

**▲/aux** **def/▼** 3. Press ▲ or ▼ until reaching the parameter "/ 5".

**Set** 4. Press "SET" to modify this selected parameter.

**▲/aux** **def/▼** 5. Press ▲ or ▼ to change value to desired setting: "0" for Celsius (°C) or "1" for Fahrenheit (°F).

**Set** 6. Press "SET" key to temporarily save the new value and return to the display of the parameter.

**Prg/mute** 7. Press & hold "Prg" key for at least 5 seconds to save changes. **Note! All values will automatically convert to new scale. No conversion is required.**

#### Warning! Save Your Parameter Settings!

1. To store the new parameter values, PRESS and HOLD the "Prg" key for at least 5 seconds.
2. All modifications made to parameters will be lost if you do NOT press a button within 60 seconds. Should this "timeout" occur, normal operational settings (prior to modifications being made) will resume.
3. If the instrument is switched off before pressing the "Prg" key, all modifications to parameters will be lost.

**def/▼** **To Activate Manual Defrost**  
Press and hold "def" key for at least 5 seconds.

**▲/aux** **To Activate / Deactivate Auxiliary Output**  
Press and hold the "aux" key for 1 second.

**Prg/mute** **▲/aux** **To Reset Any Alarms With Manual Reset**  
Press and hold the "Prg" and "aux" key for at least 1 second.



# CAREL

**ir33 platform**  
**Integrated Electronic  
 Microprocessor Controller**



## User Interface - Display

ICON	FUNCTION	DESCRIPTION	Normal operation			Start up
			ON	OFF	BLINK	
	COMPRESSOR	ON when the compressor starts. Flashes when the activation of the compressor is delayed by safety times.	Compressor on	Compressor off	awaiting activation	
	FAN	ON when the fan starts. Flashes when the activation of the fan is prevented due to external disabling or procedures in progress.	Fan on	Fan off	awaiting activation	
	DEFROST	ON when the defrost is activated. Flashes when the activation of the defrost is prevented due to external disabling or procedures in progress.	Defrost in progress	Defrost not in progress	awaiting activation	
	AUX	Flashes if the anti-sweat heater function is active, ON when the auxiliary output (1 and/or 2) selected as AUX (or LIGHT in firmware version 3.6) is activated.	AUX auxiliary output active (version 3.6 light auxiliary output active)	AUX auxiliary output not active	Anti-sweat heater function active	
	ALARM	ON following pre-activation of the delayed external digital input alarm. Flashes in the event of alarms during normal operation (e.g. high/low temperature) or in the event of alarms from an immediate or delayed external digital input.	Delayed external alarm (before the time 'A7' elapses)	No alarm present	Alarms in norm. operation (e.g. High/low temperature) or immediate or delayed alarm from external digital input	
	CLOCK	ON if at least one timed defrost has been set. At start-up, comes ON for a few seconds to indicate that the Real Time Clock is fitted.	If at least 1 timed defrost event has been set	No timed defrost event set	Alarm clock	ON if real-time clock present
	LIGHT	Flashes if the anti-sweat heater function is active, ON when the auxiliary output (1 and/or 2) selected as LIGHT is activated (in firmware version 3.6 it does not flash in anti-sweat heater mode and comes on when the dead band output is active).	Light auxiliary output on (version 3.6 dead band auxiliary output active)	Light auxiliary output off	Anti-sweat heater function active (version 3.6 does not flash in anti-sweat heater mode)	
	SERVICE	Flashes in the event of malfunctions, for example E2PROM errors or probe faults.		No malfunction	Malfunction (e.g. E2PROM error or probe fault). Contact service	
	CONTINUOUS CYCLE	ON when the CONTINUOUS CYCLE function is activated. Flashes if the activation of the function is prevented due to external disabling or procedures in progress (E.g.: minimum compressor OFF time).	CONTINUOUS CYCLE operation activated	CONTINUOUS CYCLE function not activated	CONTINUOUS CYCLE operation requested	

## Summary Table of Alarm and Signals: Display, Buzzer and Relay

Code	Icon on the display	Alarm relay	Buzzer	Reset	Description
rE	flashing	on	on	automatic	virtual control probe fault
E0	flashing	off	off	automatic	room probe S1 fault
E1	flashing	off	off	automatic	defrost probe S2 fault
E2	flashing	off	off	automatic	probe S3 fault
E3	flashing	off	off	automatic	probe S4 fault
E4	flashing	off	off	automatic	probe S5 fault
	No	off	off	automatic	probe not enabled
LO	flashing	on	on	automatic	low temperature alarm
HI	flashing	on	on	automatic	high temperature alarm
AFr	flashing	on	on	manual	antifreeze alarm
IA	flashing	on	on	automatic	immediate alarm from external contact
dA	flashing	on	on	automatic	delayed alarm from external contact
dEF	on	off	off	automatic	defrost running
Ed1	No	off	off	automatic/manual	defrost on evaporator 1 ended by timeout
Ed2	No	off	off	automatic/manual	defrost on evaporator 2 ended by timeout
Pd	flashing	on	on	automatic/manual	maximum pump down time alarm
LP	flashing	on	on	automatic/manual	low pressure alarm
AtS	flashing	on	on	automatic/manual	autostart in pump down
cht	No	off	off	automatic/manual	high condenser temperature pre-alarm
CHT	flashing	on	on	manual	high condenser temperature alarm
dor	flashing	on	on	automatic	door open too long alarm
EE	flashing	off	off	automatic	E2prom error, unit parameters
EF	flashing	off	off	automatic	E2prom error, operating parameters
ccb	Signal				start continuous cycle request
ccE	Signal				end continuous cycle request
dFb	Signal				start defrost call
dFE	Signal				end defrost call
On	Signal				switch ON
off	Signal				switch OFF
rES	Signal				reset alarms w/manual reset / reset HACCP alarms / reset temp. monitoring

# CAREL

## ir33 platform

Integrated Electronic  
Microprocessor Controller



### Summary Table of Operating Parameters

CODE	PARAMETER	UOM*	TYPE	MINIMUM	MAXIMUM	DEFAULT
/5	Select Celsius (°C) or Fahrenheit (°F)	flag	C	0	1	For Case Specific Defaults See Serial Label Located Near Electrical Access On Your Case.  For Additional Technical Information Call Structural Concepts Technical Service Dept. at 1(800) 433.9489
/c1	Calibration of probe 1	°C/°F	C	-20	20	
/c2	Calibration of probe 2	°C/°F	C	-20	20	
St	Temperature set point	°C/°F	F	r2	r1	
rd	Control delta	°C/°F	F	20	0.1	
dl	Interval between defrosts	hours	F	0	250	
dt1	End defrost temperature, evaporator	°C/°F	F	-50	200	
dP1	Maximum defrost duration, evaporator	min	F	1	250	
d6	Display on hold during defrost	-	C	0	2	
dd	Dripping time after defrost	min	F	0	15	
d/1	Display of defrost probe 1	°C/°F	F	-	-	

\* Unit Of Measure



# A & B FOODCASE QUARTERLY PREVENTATIVE MAINTENANCE

Rev. 1-28-04

Store, Name & #: \_\_\_\_\_ Date: \_\_\_\_\_

Address: \_\_\_\_\_

City, State, Zip Code, Country: \_\_\_\_\_

RC Company: \_\_\_\_\_

Technician's Name: \_\_\_\_\_

Model Make: \_\_\_\_\_

Serial #: \_\_\_\_\_

*\*All work listed below is to be done by a qualified licensed refrigeration contractor.*

<b>Compressor Section</b>	<b>Initial</b>
---------------------------	----------------

- |  |       |
|--|-------|
| 1. Check for and repair refrigeration leaks via sight glass                        | _____ |
| 2. Check compressor oil level at sight glass                                       | _____ |
| 3. Check for excessive vibrations/compressor mounts (repair if necessary)          | _____ |
| 4. Inspect all electrical plugs and connections insuring they are tight and secure | _____ |

<b>Condenser Section</b>	<b>Initial</b>
--------------------------	----------------

- |  |       |
|--|-------|
| 1. Remove foreign debris from within and around unit           | _____ |
| 2. Check and clean fan blades (as required)                    | _____ |
| 3. Clean condenser coil extensively to assure proper operation | _____ |
| 4. Straighten condensor fins with fin comb as needed           | _____ |
| 5. Clean and check operation of drain pan heater               | _____ |

<b>Evaporator Section</b>	<b>Initial</b>
---------------------------	----------------

- |  |       |
|--|-------|
| 1. Remove display deck and brush and vacuum coil, grills, fan blades and unit interior | _____ |
| 2. Clean debris from drain hole as required  | _____ |

<b>General Section</b>	<b>Initial</b>
------------------------	----------------

- |  |       |
|--|-------|
| 1. Product cannot be merchandised over air grills. If the air grills are blocked, remove product and educate the store manager that air grills cannot be blocked | _____ |
| 2. Inspect honeycomb for debris-Clean if necessary   | _____ |
| 3. Check controller settings to ensure correct product temperatures. Refer to the manual for settings  | _____ |
| 4. Check store operating conditions to ensure it does not exceed 80°/60rh  | _____ |

Comments / Does it appear the unit is being kept clean and maintained?

\_\_\_\_\_

\_\_\_\_\_

\_\_\_\_\_

Manager on Duty (Print & Sign) \_\_\_\_\_ Date: \_\_\_\_\_

**STRUCTURAL CONCEPTS CORPORATION**  
**TECHNICAL SERVICE PHONE NUMBER: 1.800.433.9489**

# Starbucks Limited Warranty

All sales by Structural Concepts Corporation (SCC) are subject to the following limited warranty. "Goods" refers to the product or products being sold by SCC.

**Warranty Scope:** Warranty is for equipment sold ONLY to Starbucks Corporation in the United States, Canada, Mexico and Puerto Rico. Equipment sold elsewhere may carry modified warranty.

**Warranty; Remedies; Limitations.** SCC warrants that if any Goods are found by an authorized representative of SCC not to be of good material or workmanship within one year of the date of shipments SCC will, at its option after inspection by an authorized representative, replace any defective Good or pay the reasonable cost of replacement for any such defective Goods, provided that written notice of the defect is given to SCC within 30 days of the appearance of such defect. If notice is not given within such period, any claim for breach of warranty shall be conclusively deemed to have been waived and SCC shall not be liable under this warranty. If SCC is unable to repair or replace the defective Goods, SCC shall issue a credit to the Purchaser for all or part of the purchase price, as SCC shall determine. The replacement or payment in the manner described above shall be the sole and exclusive remedy of Purchaser for a breach of this warranty. If any Goods are defective or fail to conform to this warranty, SCC will furnish instructions for their disposition. No Goods shall be returned to SCC without its prior consent.

SCC's liability for any defect in the Goods shall not exceed the purchase price of the Goods. SCC SHALL HAVE NO LIABILITY TO PURCHASE FOR CONSEQUENTIAL DAMAGES OF ANY KIND WHATSOEVER, INCLUDING, BUT NOT LIMITED TO, PERSONAL INJURY, PROPERTY DAMAGE, LOST PROFITS, OR OTHER ECONOMIC INJURY DUE TO ANY DEFECT IN THE GOODS OR ANY BREACH OF SCC, SCC SHALL NOT BE LIABLE TO THE PURCHASER IN TORT FOR ANY NEGLIGENT DESIGN OR MANUFACTURE OF THE GOODS, OR FOR THE OMISSION OF ANY WARNING THEREFROM.

SCC shall have no obligation or liability under this warranty for claims arising from any other party's (including Purchaser's) negligence or misuse of the Goods or environmental conditions. This warranty does not apply to any claim or damage arising from or caused by improper storage, handling, installation, maintenance, or from fire, flood, accidents, structural defects, building settlement or movement, acts of God, or other causes beyond SCC's control.

Except as expressly stated herein, SCC makes no warranty, express, implied, statutory or otherwise as to any parts or goods not manufactured by SCC. SCC shall warrant such parts or Goods only (I) against such defects, (II) for such periods of time, and (III) with such remedies, as are expressly warranted by the manufacturer of such parts of Goods. Notwithstanding the foregoing, any warranty with respect to such parts of Goods and any remedies available as a result of a breach thereof shall be subject to all of the procedures, limitations, and exclusions set forth herein.

THE WARRANTIES HEREIN ARE IN LIEU OF ALL WARRANTIES, EXPRESS, IMPLIED, STATUTORY, OR OTHERWISE. IN PARTICULAR, SCC MAKES NO WARRANTY OF MERCHANTABILITY OR FITNESS FOR A PARTICULAR PURPOSE.

No representative, agent or dealer of SCC has authority to modify, expand, or extend this Warranty, to waive any of the limitations or exclusions, or to make any different or additional warranties with respect to Goods.

**Period of Limitations.** No claim, suit or other proceeding may be brought by Purchaser for any breach of the foregoing warranty or this Agreement by SCC or in any way arising out of this Agreement or relating to the Goods after one year from the date of the breach. In the interpretation of this limitation on action for a breach by SCC, it is expressly agreed that there are no warranties of future performance of the goods that would extend that period of limitation herein contained for bringing an action.

**Indemnifications.** Purchaser agrees to indemnify, hold harmless, and defend SCC if so requested, from any and all liabilities, as defined herein, suffered, or incurred by SCC as a result of, or in connection with, any act, omission, or use of the Goods by Purchaser, its employees or customers, or any breach of this Agreement by Purchaser. Liabilities shall include all costs, claims, damages, judgments, and expenses (including reasonable attorney fees and costs).

**Remedies of SCC.** SCC's rights and remedies shall be cumulative and may be exercised from time to time. In a proceeding or action relating to the breach of this Agreement by Purchaser, Purchaser shall reimburse SCC for reasonable costs and attorney's fees incurred by SCC. No waiver by SCC of any breach of Purchaser shall be effective unless in writing nor operate as a waiver of any other breach of the same term thereafter. SCC shall not lose any right because it has not exercised it in the past.

**Applicable Law.** This Agreement is made in Michigan and shall be governed by and interpreted according to Michigan law. Any lawsuit arising out of this Agreement or the Goods may be handled by a federal or state court whose district includes Muskegon County, Michigan, and Purchaser consents that such court shall have personal jurisdiction over Purchaser.

**Miscellaneous.** If any provision of this Agreement is found to be invalid or unenforceable under any law, the provision shall be ineffective to that extent and for the duration of the illegality, but the remaining provisions shall be unaffected. Purchaser shall not assign any of its rights nor delegate any of its obligations under this Agreement without prior written consent of SCC. This Agreement shall be binding upon and inure to the benefit of SCC and Purchaser and each of their legal representatives, successors and assigns.

SCC warrants its products to be free of defects in materials and workmanship under normal use and service for a period of one (1) year.

This warranty is extended only to the original purchaser for use of the Goods. It does not cover normal wear parts such as plastic tongs, tong holders, tong cables, bag holders, or acrylic dividers.

**General Conditions.** All service labor and/or parts charges are subject to approval by SCC. Contact the Customer Service Department in writing or call 1.800.433.9489.

All claims must contain the following information: (1) model & serial code number of equipment; (2) the date and place of installation; (3) the name and address of the agency which performed the installation; (4) the date of the equipment failure; and (5) a complete description of the equipment failure and all circumstances relating to that failure.

Once the claim has been determined to be a true warranty claim by SCC's Customer Service Department, the following procedure will be taken: (1) replacement parts will be sent at no charge from SCC on a freight prepaid basis; (2) reimbursement for service labor will be paid if the following conditions have been met - (a) prior approval of service agency was awarded from the Customer Service Department; and (b) an itemized statement of all labor charges incurred is received by the Customer Service Department. The cost of the service labor reimbursement will be based on straight time rates and reasonable time for the repair of the defect.

If problems occur with any compressor, notify SCC's Customer Service Department immediately. Any attempt to repair or alter the unit without prior consent from the Customer Service Department may render any warranty claim null and void. This warranty and protection plan does not apply to any condensing unit or any part thereof which has been subject to accident, negligence, misuse, or abuse, or which has not been operated in accordance with the manufacturer's recommendations or if the serial number of the unit has been altered, defaced, or removed.

**Limit of Liability.** The limit of liability of SCC toward the exchange cost of the original compressor motor is one year parts and labor. A motor-compressor replaced during the warranty shall not exceed manufacturer's current established wholesaler's exchange price.