

TYPICAL PRECAST MANHOLE DETAIL - TYPE D
Depth from ground level to soffit of pipe 1 - 1.5m

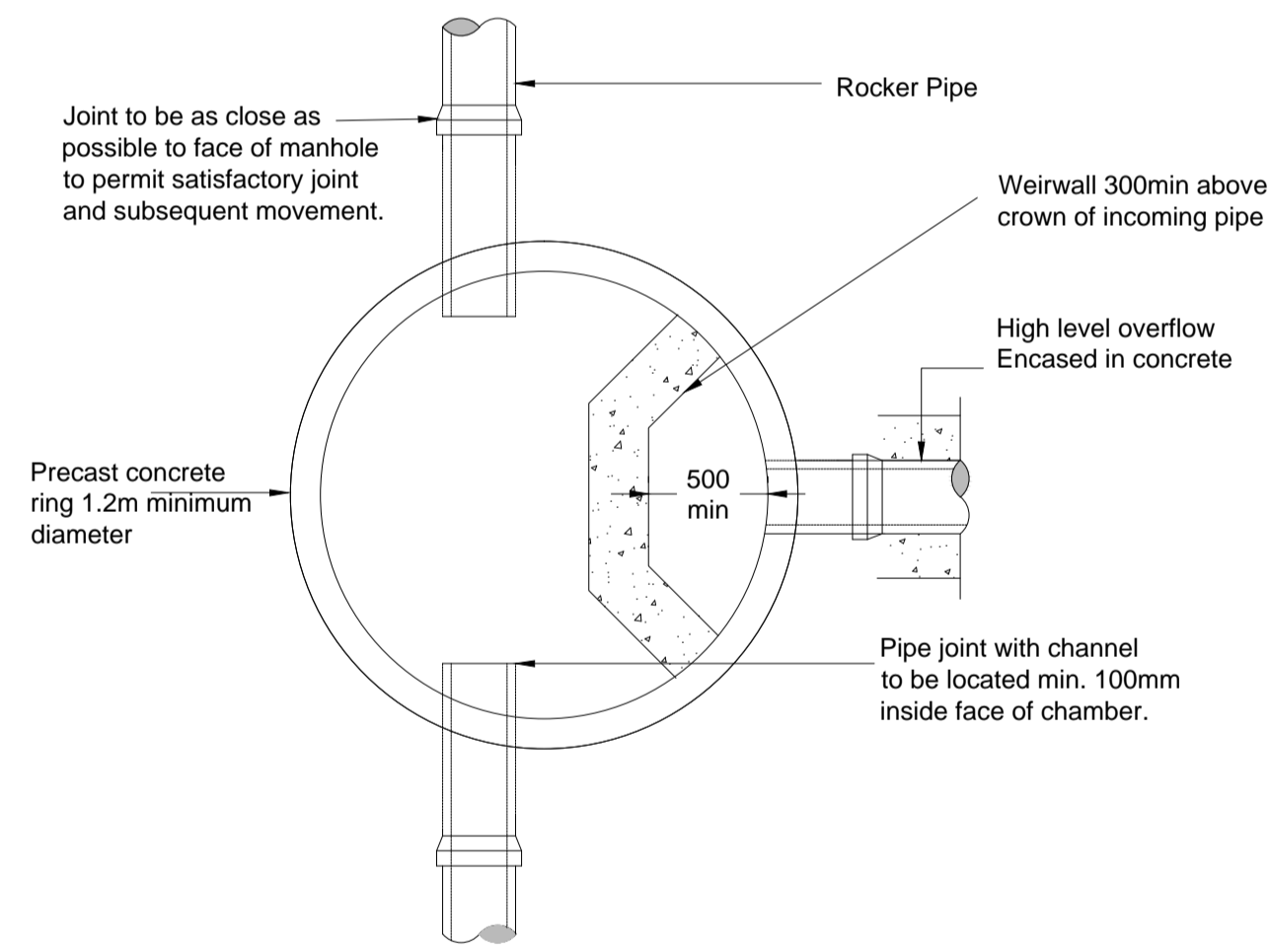

PLAN ON MANHOLE TYPE D

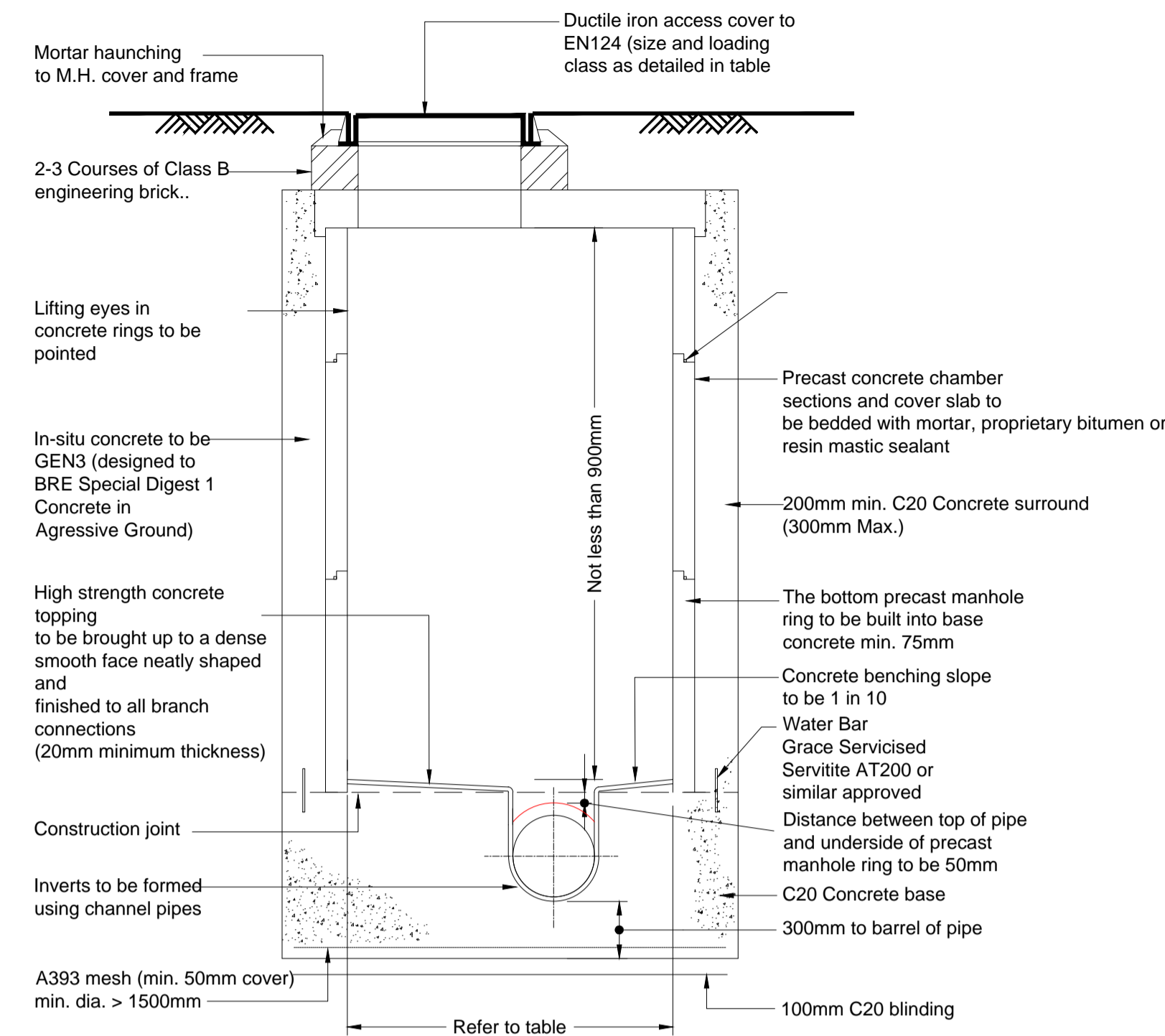

TYPICAL PRECAST MANHOLE DETAIL - TYPE B
Maximum depth from cover level to soffit of pipe 3.0m

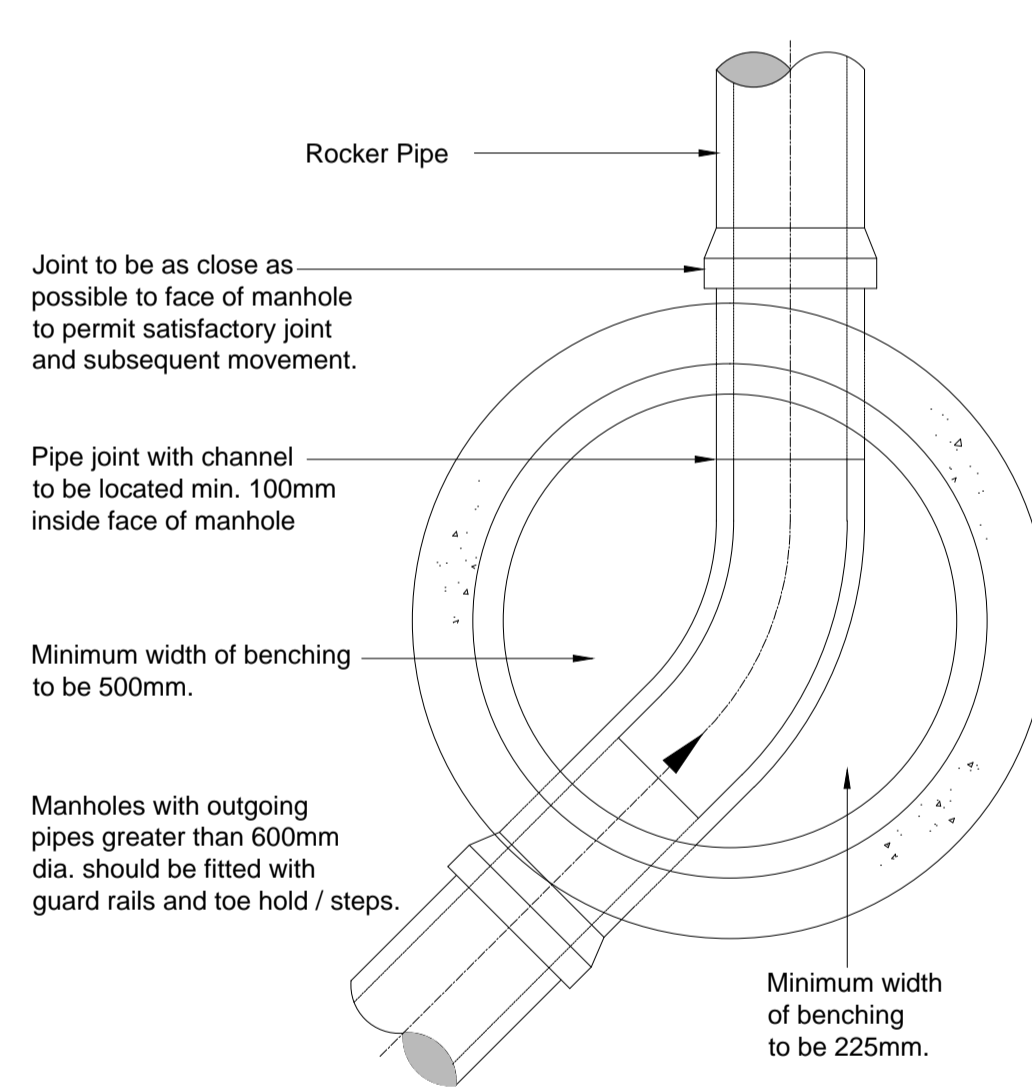

PLAN ON MANHOLE TYPE B

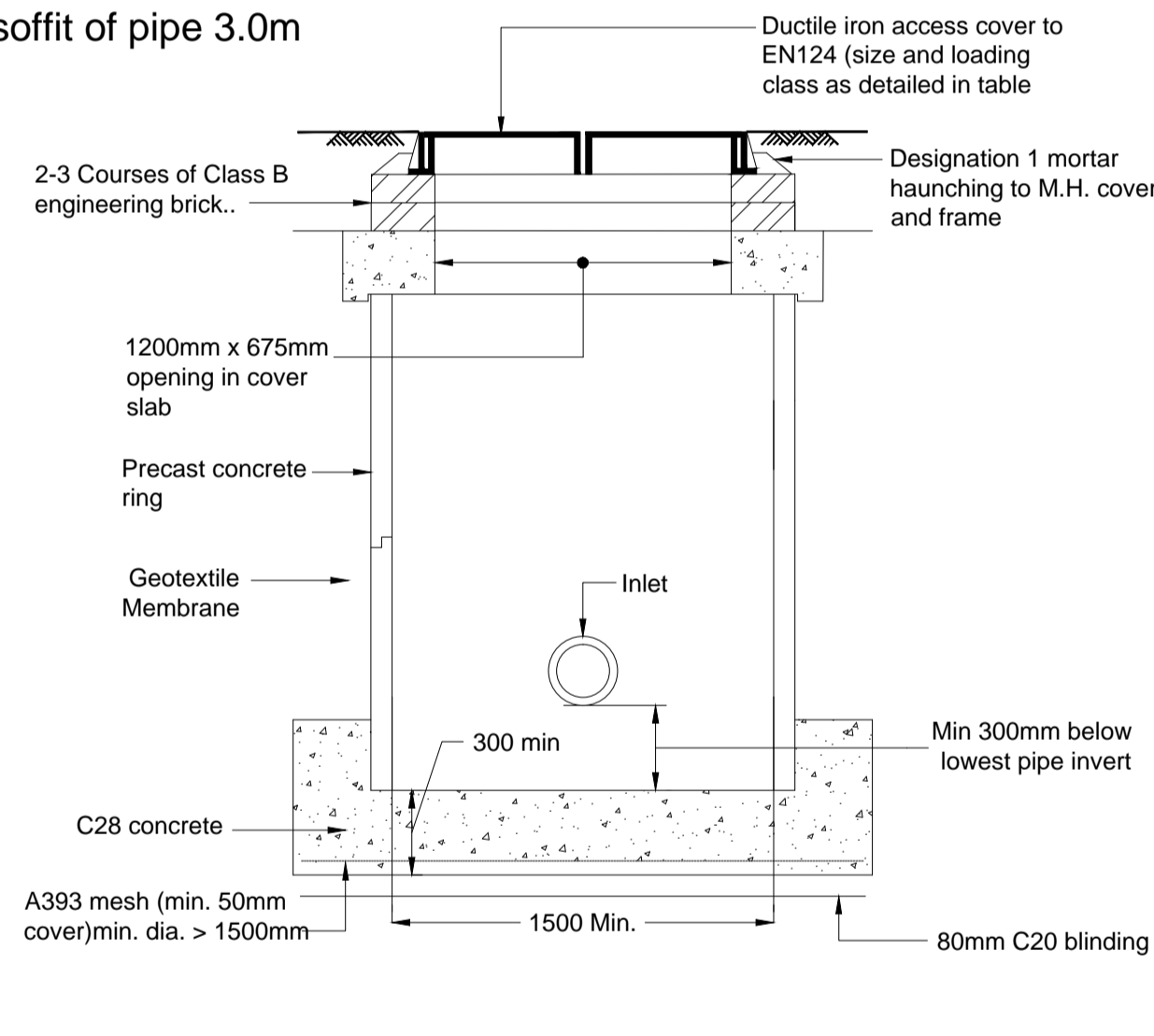

TYPICAL PRECAST MANHOLE DETAIL - TYPE E
Depth from ground level to soffit of pipe 1 - 1.5m

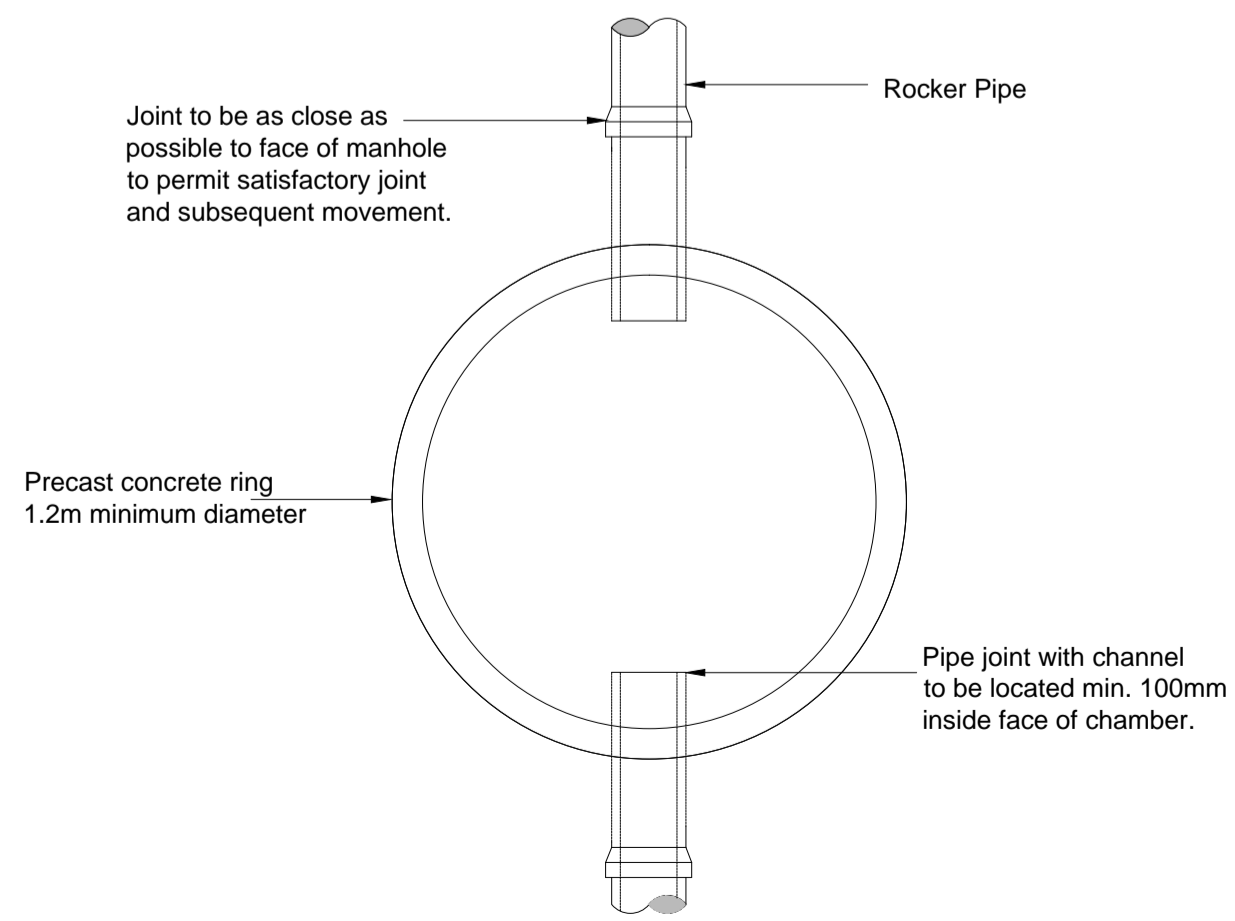

PLAN ON MANHOLE TYPE E

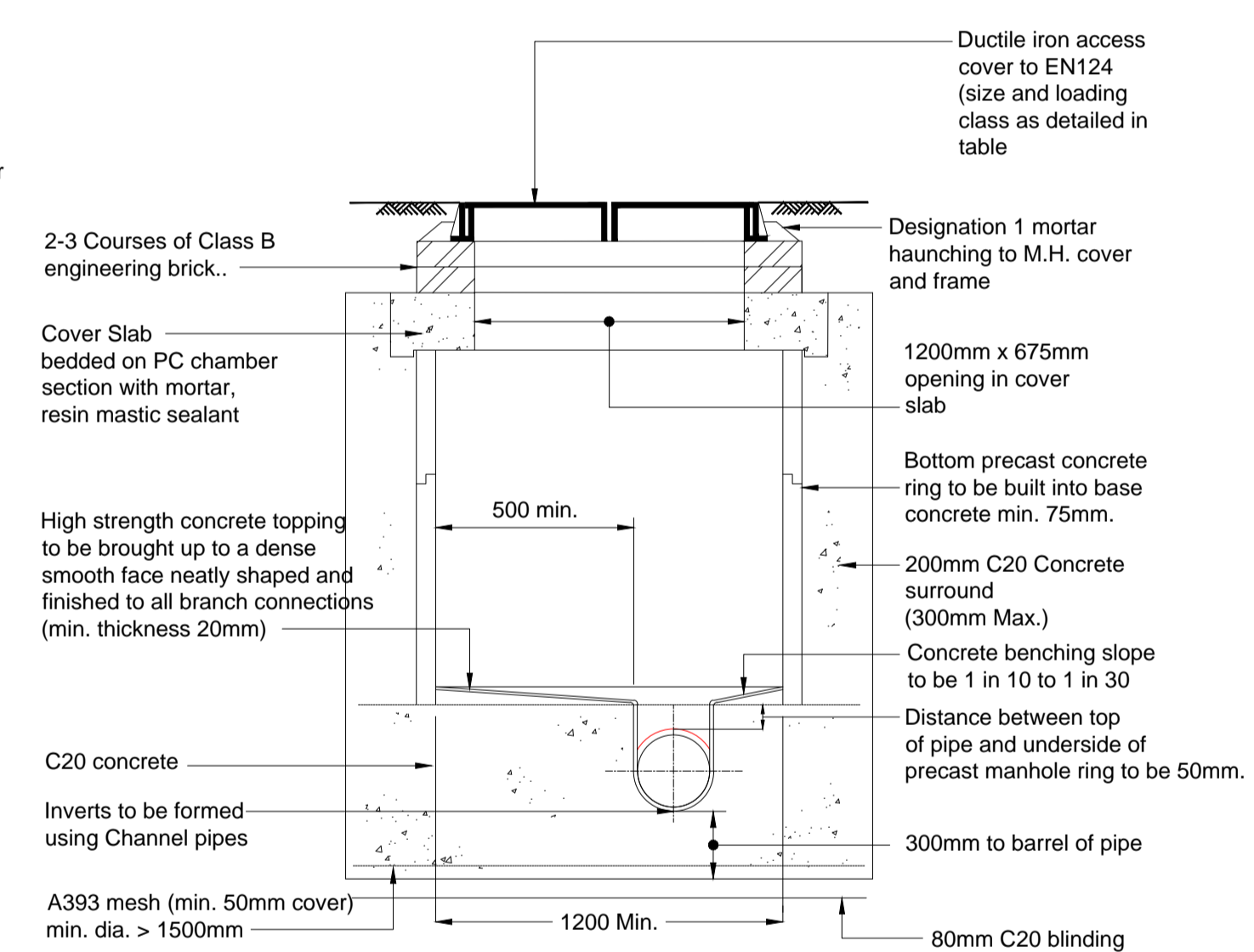

TYPICAL PRECAST MANHOLE DETAIL - TYPE C
Depth from ground level to soffit of pipe 1.0 - 1.45m

TYPE OF ACCESS	DEPTH FROM SOFFIT TO COVER LEVEL (m)	DN LARGEST PIPE IN MANHOLE / MEANS OF DESCENT INTO SHAFT	MINIMUM INTERNAL DIMENSIONS	MINIMUM ACCESS SIZE		REMARKS
				RECTANGULAR	CIRCULAR	
MANHOLE C	1.0 - 1.5	≤ 150mmØ	1000mmØ	750 x 750 C	600Ø	Generally in accordance with safe work in confined spaces - Health and safety commission Larger opening size is required for manholes at shallower depths to permit standing / crouching Cover loading class C250 in fields and D400 in roads / road margins
		225mmØ	1200mmØ	750 x 600 E	750Ø	
		300mmØ	1200mmØ	750 x 600 E		
		375mmØ to 450mmØ	1350mmØ	1200 x 675 C		
		500mmØ to 700mmØ	1500mmØ	1200 x 675 C		
MANHOLE B	1.5 - 3.0	≥ 225mmØ	1200mmØ	750 x 600 E	700Ø	Where a ladder is provided, a larger size may be needed Cover loading class C250 in fields and D400 in roads / road margins
		300mmØ	1200mmØ	750 x 600 E		
		375mmØ to 450mmØ	1350mmØ	750 x 600 E		
		500mmØ to 700mmØ	1500mmØ	750 x 600 E		
		750mmØ to 900mmØ	1800mmØ	1200 x 675 C		
I. These sizes apply to straight-through pipes; larger sizes may be required for turning chambers or chambers with several side branches or where specific maintenance requirements are necessary, e.g. disconnecting traps. II. Minimum height of chamber in shafted manhole 2m from benching to underside of reducing slab. III. May be reduced to 600 x 600 or 600Ø where the configuration of the manhole chamber permits a safe system of work. IV. C denotes central. V. E denotes eccentric.						

NOTES :

- FIGURED DIMENSIONS ONLY TO BE TAKEN FROM THIS DRAWING.
- ALL DRAWINGS TO BE CHECKED BY THE CONTRACTOR ON SITE.
- ENGINEER/EMPLOYERS REPRESENTATIVE, AS APPROPRIATE, TO BE INFORMED BY THE CONTRACTOR OF ANY DISCREPANCIES BEFORE ANY WORK COMMENCES.
- THE CONTRACTOR SHALL UNDERTAKE A THOROUGH CHECK FOR THE ACTUAL LOCATION OF ALL SERVICES/UTILITIES, ABOVE AND BELOW GROUND, BEFORE ANY WORK COMMENCES.
- ALL LEVELS SHOWN RELATE TO ORDINANCE SURVEY DATUM AT MALIN HEAD.

Rev	Date	Description	By	Chkd.
A	Dec '15	PLANNING ISSUE	MN	DC

Client: **EIRGRID**

Project: **WEST DUBLIN 220 / 110 KV SUBSTATION & ASSOCIATED WORKS**

Title: **TYPICAL MANHOLE DETAILS**

Scale @ A1: **1:25**

Prepared by: **M. Nolan** Checked: **D. Conneran** Date: **October 2015**

Project Director: **D. Grehan**

Drawing Status: **Planning**

TOBIN AZCOM
Partners: Tobin & Co. Ltd.

TOBIN Consulting Engineers, Block 10-4, Blanchardstown Corporate Park, Dublin 15, Ireland.
tel: +353-(0)1-8030406
fax: +353-(0)1-8030409
e-mail: dublin@tobin.ie
www.tobin.ie

AECOM, Kingswood Drive, City West Business Campus, Dublin 24, Ireland.
T +353 (0) 1 403 9300

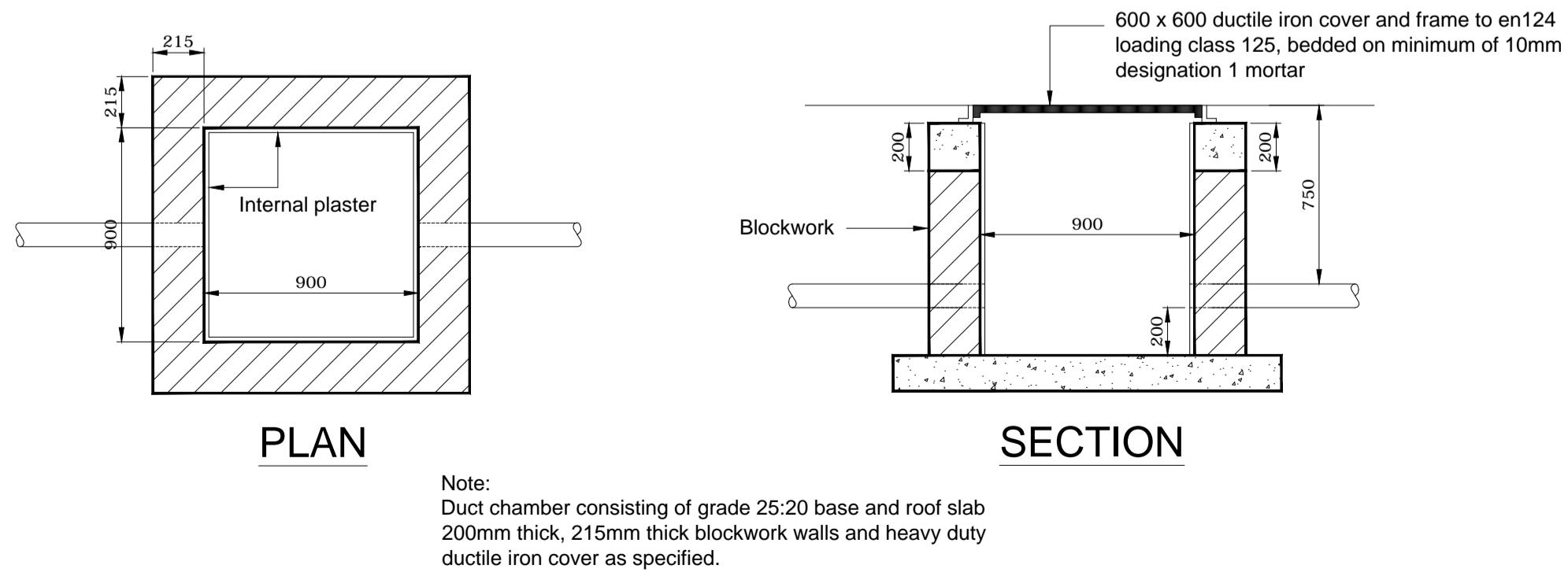

TYPICAL DUCT CHAMBER DETAIL

Note:
Duct chamber consisting of grade 25:20 base and roof slab 200mm thick, 215mm thick blockwork walls and heavy duty ductile iron cover as specified.