

***American National Standard
Voluntary Industry Performance Standards
for Pressure and Velocity
of Rimfire Sporting Ammunition
for the Use of Commercial Manufacturers***

American National Standards Institute

Headquarters

11 West 42nd Street, 13th Floor

New York, NY 10036

Tel: 212 642-4900 Fax: 212 398-0023

**Voluntary Industry Performance Standards
for Pressure and Velocity
of Rimfire Sporting Ammunition
for the Use of Commercial Manufacturers**

Sponsor

Sporting Arms and Ammunition Manufacturers' Institute, Inc.

Members

**Beretta USA Corporation
Broadsword Group LLC
Browning Arms Company
CCI/Speer Ammunition
Colt's Manufacturing Company LLC
COR-BON/Glaser LLC
Federal Cartridge Company
Fiocchi of America, Inc.
Glock
Hodgdon Powder Company
Hornady Manufacturing Company
Kahr Arms**

**Marlin Firearms Company
North American Arms, Inc.
O.F. Mossberg & Sons, Inc.
Olin Corporation/Winchester Division
Remington Arms Company, LLC
Savage Arms, Inc.
SIG SAUER, Inc.
Smith & Wesson Holding Corp.
St. Marks Powder, Inc.
Sturm, Ruger & Co., Inc.
Taurus Holdings, Inc.
Weatherby, Inc.**

Associate Members:

**New River Energetics, LLC
Nosler, Inc.
Ruag Ammotech USA, Inc.**

Supporting Members:

**Advanced Tactical Armament Concepts, LLC
Barnes Bullets, LLC
Black Hills Ammunition, Inc.
Doubletap Ammunition, Inc.
Kent Cartridge, America
Knight Rifles
MAC Ammo
One Shot, Inc.
Southern Ballistic Research, LLC d/b/a SBR
War Sport Industries, LLC**

**Approved August 31, 2015
American National Standards Institute**

Abstract

In the interests of safety and interchangeability, this Standard provides pressure and velocity performance and dimensional characteristics for rimfire sporting ammunition. Included are procedures and equipment for determining these criteria.

American National Standard

Approval of an American National Standard requires verification by ANSI that the requirements for due process, consensus, and other criteria for approval have been met by the standards developer.

Consensus is established when, in the judgment of the ANSI Board of Standards Review, substantial agreement has been reached by directly and materially affected interests. Substantial agreement means much more than a simple majority, but not necessarily unanimity. Consensus requires that all views and objections be considered, and that a concerted effort be made toward their resolution.

The use of American National Standards is completely voluntary; their existence does not in any respect preclude anyone, whether he has approved the standards or not, from manufacturing, marketing, purchasing, or using products, processes, or procedures not conforming to the standards.

The American National Standards Institute does not develop standards and will in no circumstances give an interpretation of any American National Standard. Moreover, no person shall have the right or authority to issue an interpretation of an American National Standard in the name of the American National Standards Institute. Requests for interpretation should be addressed to the secretariat or sponsor whose name appears on the title page of this standard.

CAUTION NOTICE: This American National Standard may be revised or withdrawn at any time. The procedures of the American National Standards Institute require that action be taken to reaffirm, revise, or withdraw this standard no later than five years from the date of approval. Purchasers of American National Standards may receive current information of all standards by calling or writing the American National Standards Institute.

Published by

***Sporting Arms and Ammunition Manufacturers' Institute, Inc.
Flintlock Ridge Office Center
11 Mile Hill Road, Newtown, Connecticut 06470-2359***

Copyright © 2015 by
Sporting Arms and Ammunition Manufacturers' Institute, Inc.
All rights reserved.

No part of this publication may be reproduced in any form,
in an electronic retrieval system or otherwise, without
the prior written permission of the publisher.

Printed in the United States of America

(This foreword is not part of the American National Standard Z299.1-2015)

Foreword

The development of this voluntary industry performance standard was initiated under the auspices of the Sporting Arms and Ammunition Manufacturers' Institute, Inc. (SAAMI). A Product Standards Task Force was established by the Institute in 1975 and charged with the drafting of this and other standards and their subsequent periodic revisions.

The material presented provides the commercial manufacturer of factory-loaded ammunition with pressure and velocity performance and dimensional characteristics. Included are procedures and equipment for determining these criteria. For the purpose of this standard a commercial manufacturer is defined as one who produces ammunition by fabricating component parts from raw materials as opposed to remanufacture with parts originally made by others.

This standard for Rimfire Sporting Ammunition was first published in 1975. Subsequently it was revised at five year intervals, in 1977, 1982, 1988, 1992 and now again in 2015. Changes in the standard with each revision include minor adjustments of velocities, the addition of new load offerings, and updating of recommended equipment sources and the latest procedures for reporting reference ammunition assessments.

Suggestions for improvement of this standard will be welcome. They should be sent to: The Sporting Arms and Ammunition Manufacturers' Institute, Inc., Flintlock Ridge Office Center, 11 Mile Hill Road, Newtown, Connecticut 06470-2359.

Consensus for this standard was achieved by use of the Canvass Method.

The following individuals and organizations recognized as having an interest in the standardization of safety requirements for factory-loaded sporting ammunition were contacted prior to the approval of this standard. Inclusion in this list does not necessarily imply that the individual or organization concurred with the submittal of the standard to ANSI:

Aberdeen Proving Grounds – P. Donahue
Association of Firearm and Toolmark Examiners – L. Haag
Association of Firearm and Toolmark Examiners – J. Hamby, M.A.
Boone Ballistics, LLC – B. Boone
BPI Outdoors/Bergara Barrel and Custom Rifle Division – M. Hendricks
Bureau of Alcohol, Tobacco, Firearms and Explosives – E. Griffith
Department of Homeland Security; National Armory – L. Johnson
FACTS Laboratory, LLC – K. Greene
Federal Bureau of Investigation – A. S. Patterson
Federal Law Enforcement Training Center (FLETC) – C. Nester, Jr
Forensic Ammunition Service – G. Kass
H.P. White Laboratory – W. Mason
H-S Precision, Inc – T. Houghton
Independent Author, Editor and Firearms Manufacturer - R. Cofield
Manson Precision Reamers; Division of Loon Lake Precision – D. Manson
Massachusetts Institute of Firearms Technology – C. Hildebrandt
National Institute of Standards & Technology – K. Rice
Natural Resources – Canada – R. Bowes
PCB Piezotronics – R. Metz
Royal Canadian Mounted Police – R. Poaps
Western Powders – D. Luhr

TABLE OF CONTENTS

<u>SECTION I – CHARACTERISTICS</u>	<u>PAGE</u>
Rimfire Cartridges and Chambers	
Full and Abbreviated Names	1
Velocity & Pressure	
Velocity Data Interpretation	2
Factors Affecting Pressure Measurements.....	3
Explanation of Pressure Terminology	4
Rimfire Velocity & Pressure Data - Transducer.....	6
Cartridge and Chamber Drawings	
17 Mach 2	9
17 Hornady Magnum Rimfire.....	10
17 Winchester Super Magnum.....	11
22 Short.....	12
22 Long	13
22 Long Rifle - Match.....	14
22 Long Rifle - Sporting	15
22 Long Rifle - Shot	16
22 Winchester Rimfire.....	17
22 Winchester Magnum.....	18
Miscellaneous	
Dummy Cartridge: Gun Functioning	19
Dummy Cartridge: Display.....	20
Headspace: 17 Mach 2	21
Headspace: 17 Hornady Magnum Rimfire	22
Headspace: 17 Winchester Super Magnum	23
Headspace: 22 Short, 22 Long, 22 Long Rifle and 22 Long Rifle Shot.....	24
Headspace: 22 Winchester Rimfire and 22 Winchester Magnum	25
Tolerance: Bullet Weight.....	26
<u>SECTION II - PROCEDURES</u>	
Velocity and Pressure	
Velocity & Pressure Barrels: Qualification	27
Velocity & Pressure Barrels: Mounting in Receivers.....	28
Velocity and Conformal Piezoelectric Transducer Pressure Testing	29
Transducer Calibration: Equipment Interconnection.....	37
Transducer Calibration: Least Square Line Computation	38
Firing Test: Equipment Interconnection	40
Reference Ammunition	
Use	42
Secondary Reference Ammunition	44
New Lots	45

Identification Protocol48
Periodic Assessment49

SECTION III – EQUIPMENT

Equipment: Velocity and Conformal Piezoelectric Pressure Testing.....53
Supplier Contact Information55
Schematic Layout of Velocity Screens56
Universal Receiver Collar and Test Barrel57
Universal Receiver Test Barrel: Installation of Pressure Transducers59
Standard V&P Test Barrels - General
 Procedures for Dimensioning Chambers60
 Procedures for Measuring Barrel Length.....61
Standard Velocity and Pressure Test Barrels
 17 Mach 262
 17 Hornady Magnum Rimfire.....63
 17 Winchester Super Magnum.....64
 22 Short.....65
 22 Long and 22 Long Rifle66
 22 Long Rifle Shot.....67
 22 Winchester Rimfire68
 22 Winchester Magnum69
Headspace Gauges
 17 Mach 270
 17 Hornady Magnum Rimfire.....71
 17 Winchester Super Magnum.....72
 22 Short, 22 Long, 22 Long Rifle, 22 Long Rifle Shot73
 22 Winchester Rimfire and 22 Winchester Magnum74
Reference Ammunition Supply.....75
Reference Ammunition Order Procedure76

SECTION IV – DEFINITIVE PROOF LOADS

Definition and Purpose77
Pressure Data Interpretation.....78
Proof Pressure Data – Transducer.....79
Proof Load Supply80
Proof Cartridge Identification81
Definitive Proof Package Identification.....82

FULL AND ABBREVIATED NAMES

The following list presents the recommended full names and abbreviated names of the rimfire cartridges and chambers currently supplied for various types of firearms.

These full or abbreviated names should be used on cartridge packaging and on firearm markings to properly identify the caliber.

ORDER OF LISTING

Lists of rimfire cartridges are arranged according to the following rules:

- 1) All Metric cartridges
 - a) First in ascending numerical order of approximate caliber designation,
 - b) Then in alphabetical order.

- 2) Followed by American cartridges
 - a) First in ascending numerical order of approximate caliber designation,
 - b) Then in order of actual cartridge case length, from shortest to longest.
 - c) Then in ascending order of nominal velocity.

- 3) Within each of the above groups, cartridges are arranged in order of:
 - a) 2-digit numbers,
 - b) 2-digit numbers and a hyphen followed by more numbers,
 - c) 3-digit numbers.

For lists that present both cartridge name and several bullet weights, list in ascending numerical order of bullet weights.

Active Cartridges and Chambers

<u>Full Name</u>	<u>Abbreviated Name</u>
17 Mach 2	17 M 2
17 Hornady Magnum Rimfire.....	17 HMR
17 Winchester Super Magnum.....	17 Win Super Mag
22 Short.....	22 S
22 Long	22 L
22 Long Rifle	22 LR
22 Winchester Rimfire	22 WRF
22 Winchester Magnum (Rimfire) *	22 WMR
	or 22 Win Mag
	or (22 WMRF)*

* Descriptions in parenthesis “()” are obsolete terms.

VELOCITY DATA INTERPRETATION

Velocity recommendations are stated on the basis of a nominal lot mean velocity as measured using equipment in accordance with the requirements of Section III and the procedures detailed in Section II. Due to the fact that sporting firearms for general distribution are typically manufactured to dimensional tolerances greater than those specified for test barrels, there should be no expectation that these velocities can be duplicated from any test utilizing firearms. This situation is further confounded by discrepancies in barrel length. Furthermore, once ammunition has left the control of the manufacturer, storage conditions outside those recommended by the manufacturer may cause variations in the velocity as measured using test equipment and procedures which conform to the requirements of this Standard.

The values presented on pages 6ff are recommended values for the use of ammunition producers at the time of manufacture. It is the responsibility of the manufacturer to establish sample sizes, sampling frequencies, and tolerances to ensure the performance of the ammunition obtained by the ultimate user meets all applicable safety and functional standards. Of particular importance in establishing velocity tolerances is the understanding that velocities significantly higher than the nominal lot mean can cause actual maximum range performance to exceed expected values.

Ammunition tested subsequent to manufacture using equipment and procedures conforming to these guidelines can be expected to produce velocities within a tolerance of ± 90 fps of the tabulated values.

FACTORS AFFECTING PRESSURE MEASUREMENTS

There are three principal factors affecting pressure measurements. These are instrumentation, ammunition and procedure. The following lists present the items in each category that may cause difficulties in testing.

INSTRUMENTATION

1. Condition of test barrel (whether minimum or maximum bore, chamber size and headspace, amount of erosion at throat and bore).
2. Fit of transducer in barrel.
3. Location of transducer.
4. Tightness of barrel mounting in Universal Receiver, if used.
5. Shape, size and protrusion of firing pin beyond breech face.
6. Force of firing pin blow.
7. Characteristics of the transducer.
8. Quality of the transducer.
9. Quality of the read-out system.

AMMUNITION

1. Condition of cartridge.
2. Temperature of ammunition.

PROCEDURE

1. Failure to mount pressure barrel properly in Universal Receiver or other test action to assure minimum headspace.
2. Failure to fire warming shots.
3. Overheating barrel by excessive rate of fire.
4. Failure to clean bore and control metal fouling.
5. Failure to protect transducer against contamination, such as oil or water.
6. Transducer calibration.
7. Read-out system calibration.

EXPLANATION OF PRESSURE TERMINOLOGY

The SAAMI Pressure data outlined in this section is based on a Maximum Average Pressure (MAP) for each cartridge and a Coefficient of Variation of 4%. The Coefficient of Variation (CV) of 4% was based on the CV that exists for the 24,000 psi pressure level and is calculated by dividing the population standard deviation ($\sigma = 960$) by the Maximum Average Pressure (MAP = 24,000 psi) which equals 0.04. All other pressure terminology is derived directly from these two terms.

[NOTE: Experience has shown that with the 22 Winchester Magnum cartridge, variations that are higher than normal Rimfire occur. As a result, a coefficient of variation of 0.10 has been established for this cartridge.]

SAAMI recognizes one pressure-measuring system for rimfire ammunition. That system is the piezoelectric transducer system with the transducer flush-mounted in the chamber of the test barrel. Pressure developed by the burning propellant exerts force on the transducer through the cartridge case wall causing the transducer to deflect, creating a measurable electric charge. Pressures measured with this system are expressed in units of "pounds per square inch" (abbreviated "psi").

Maximum Average Pressure - is the recommended maximum pressure level for loading commercial sporting ammunition. This pressure level is positioned two standard errors below the Maximum Probable Lot Mean (MPLM) pressure in order to assure there is a 97.5% probability that the Maximum Probable Lot Mean pressure is not exceeded. See Figure 1.

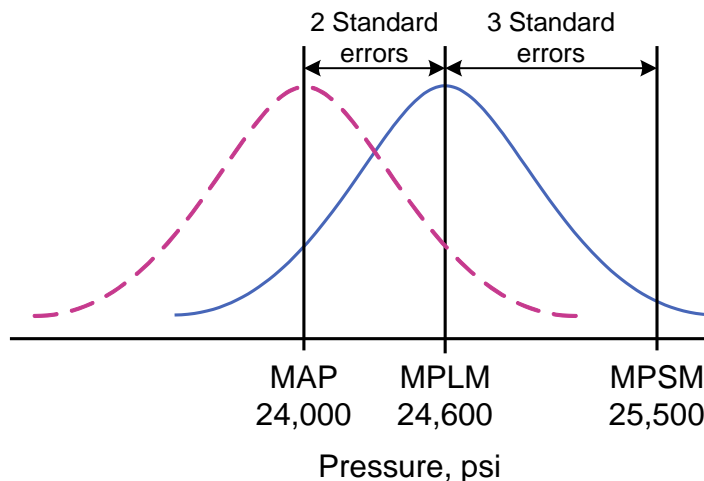

Figure 1

Standard Deviation (σ) - The Standard Deviation for each Maximum Average Pressure Level is based on a Coefficient of Variation of 4%. This 4% Coefficient of Variation is maintained throughout the SAAMI pressure spectrum providing a realistic Standard Deviation for each pressure level. To obtain the Standard Deviation for a particular MAP, multiply the MAP by 0.04 (i.e., 24,000 psi x 0.04 = 960 psi).

Standard Error (σ_x) - The standard error is calculated by dividing the Standard Deviation (population S. D. = σ) by the square root of the sample size $\sigma_x = \sigma/\sqrt{n}$

Maximum Probable Lot Mean (MPLM) - The MPLM is calculated by adding two standard errors to the Maximum Average Pressure.

The SAAMI pressures are calculated based on a sample size of ten (10). The Maximum Probable Lot Mean represents the midpoint of the upper service pressure distribution. See Figure 1. For example, if the Maximum Average Pressure is 24,000 psi, the Maximum Probable Lot Mean (MPLM) is calculated as follows:

MPLM = Maximum Average Pressure + 2 standard errors

MPLM = 24,000 psi + [(24,000 psi x 0.04)/ $\sqrt{10}$] x 2

MPLM = 24,000 psi + (304 psi x 2) = 24,000 psi + 608 psi = 24,608 psi rounded
to 24,600 psi

Maximum Probable Sample Mean (MPSM) - is the maximum expected average pressure that may be observed in the testing of product subsequent to its manufacture and is not intended for use as a loading control point. The Maximum Probable Sample Mean is positioned three (3) standard errors above the Maximum Probable Lot Mean i.e., MPLM + 3 σ_x . See Figure 1. The Maximum Probable Sample Mean defined here is the value previously referred to in the ANSI/SAAMI Standards as the Maximum Product Average.

Maximum Extreme Variation - The maximum allowable sample E.V. (Extreme Variation or Range) is a statistic derived from the knowledge of the population Standard Deviation. Applying table figures from the Relative Range Tables (Biometrika Tables for Statisticians) we calculate the Maximum E.V. or Range as (population σ) x 5.16 (table constant for sample of 10 at 99.0% confidence level) i.e., 960 psi x 5.16 = 4,953.6 psi rounded up to 5,000 psi.

**VELOCITY AND PRESSURE:
RIMFIRE VELOCITY AND PRESSURE DATA - TRANSDUCER**

Cartridge	Bullet		Velocity (fps) Nominal Mean Instrumental @ 15' Test Bbl.	Pressure Limits (psi/100) ⁽¹⁾		
	Weight (gr.)	Type		Maximum Average Pressure (MAP)	Maximum Probable Lot Mean (MPLM)	Maximum Probable Sample Mean (MPSM)
17 Mach 2	17	PT	2,010	240	246	255
17 Hornady Magnum Rimfire	15½	PT-NL ⁽²⁾	2,475	260	267	277
	17	PT	2,525			
	20	JHP	2,350			
17 Winchester Super Magnum	20	PT	3,000	330	338	350
	25	PT	2,600			
	27	HPL	1,105			
22 Short		SL	710	210	215	223
	29	SL	1,035			
		SL	1,080			
22 Long	29	SL	1,215	240	246	255
22 Long Rifle	25	#12 Shot	1,000	240	246	255
	26	HP-NL ⁽²⁾	1,625			
	31	TCHP	1,550			
	33	TCHP	735			
			1,465			
	36	HPL	1,200			
			1,260			
			1,385			
	37	HPL	1,260			
			1,310			
	40	SL	1,370			
			1,040			
			1,080			
1,135						
1,235						
42	TCSB	HSP				
		1,275				
	HP	1,435				
		1,200				

⁽¹⁾ Based on sample size $\eta=10$.

⁽²⁾ NL = Non-Lead

**VELOCITY AND PRESSURE:
VELOCITY AND PRESSURE DATA - TRANSDUCER**

Cartridge	Bullet		Velocity (fps) Nominal Mean Instrumental @ 15' Test Bbl.	Pressure Limits (psi/100) ⁽¹⁾		
	Weight (gr.)	Type		Maximum Average Pressure (MAP)	Maximum Probable Lot Mean (MPLM)	Maximum Probable Sample Mean (MPSM)
22 Winchester Rimfire	45	JHP	1,300	200	205	213
	28	JHP NL ⁽³⁾	2,175			
	30	JHP	2,200			
22 Winchester Magnum ⁽²⁾	33	PT	1,950	240	255	278
	34	JHP	2,075			
	40	FMC-HSP-SP	1,875			
	45	LHP	1,550			
	50	JHP	1,650			

⁽¹⁾ Based on sample size $n=10$.

⁽²⁾ Experience has shown that with the 22 WMR cartridge variations that are higher than normal Rimfire occur. As a result, a standard deviation of 2,400 psi has been established for this cartridge.

⁽³⁾ NL = Non-Lead

**VELOCITY AND PRESSURE:
VELOCITY AND PRESSURE DATA – TRANSDUCER
RIMFIRE MATCH CARTRIDGES**

Cartridge	Bullet		Velocity (fps) Nominal Mean Instrumental @ 15' Test Bbl.	Pressure Limits (psi/100) ⁽¹⁾		
	Weight (gr.)	Type		Maximum Average Pressure (MAP)	Maximum Probable Lot Mean (MPLM)	Maximum Probable Sample Mean (MPSM)
22 LR Rifle Match	40	SL	1,100	240	246	255
22 LR Pistol Match	40	SL	1,135	240	246	255

⁽¹⁾ Based on sample size $n=10$.

The velocity figures listed above are nominal values; optimum accuracy may require a velocity different from the nominal figure.

NOTE: Where manufacturer’s practices produce values different in any respect from those tabulated, those practices shall be considered acceptable when they are statistically equivalent.

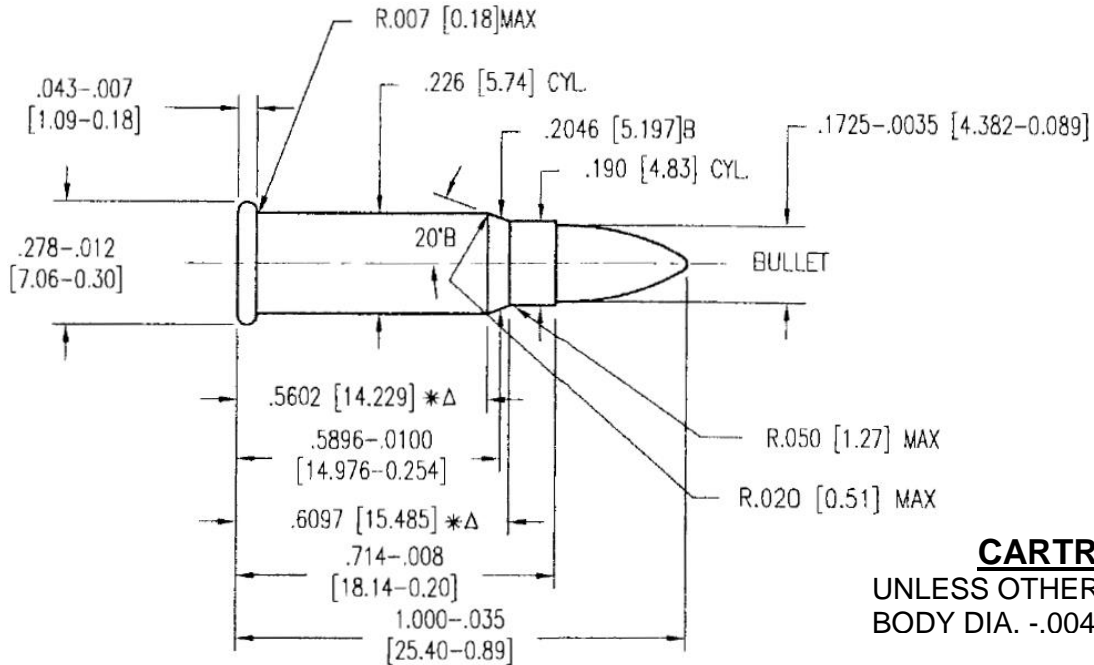

CARTRIDGE
UNLESS OTHERWISE NOTED
BODY DIA. -.004 (0.10)

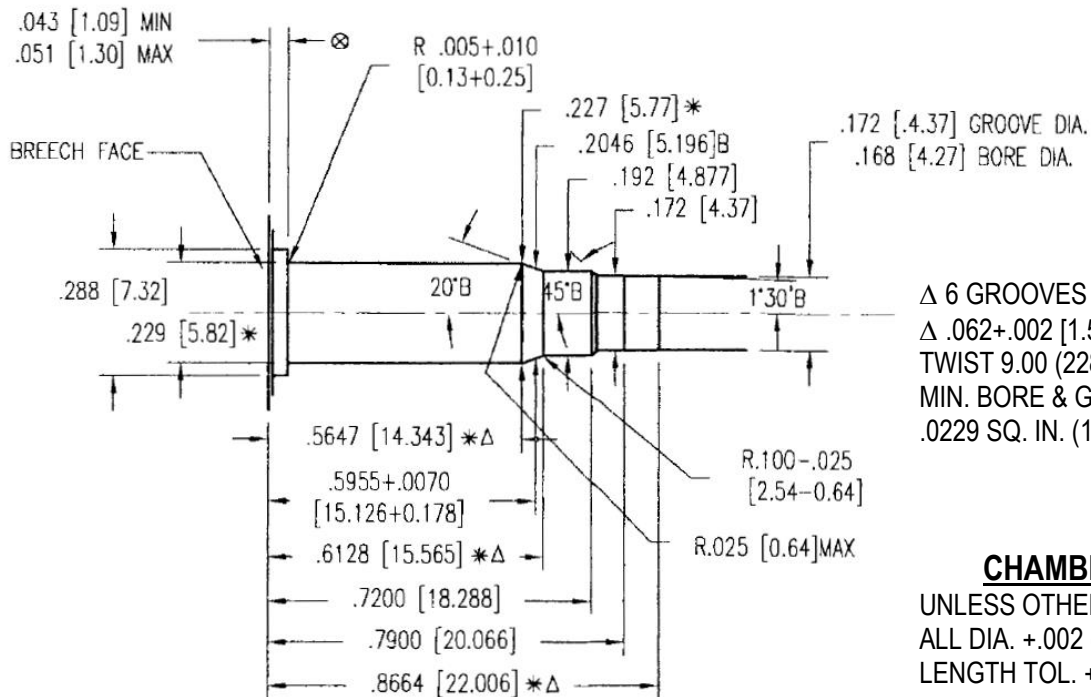

Δ 6 GROOVES
Δ .062+.002 [1.57+0.05] WIDE
TWIST 9.00 (228.6) RH - OPTIONAL
MIN. BORE & GROOVE AREA
.0229 SQ. IN. (14.774 mm²)

CHAMBER
UNLESS OTHERWISE NOTED
ALL DIA. +.002 (0.05)
LENGTH TOL. +.015 (0.38)

NOTE
B = BASIC (XX.XX) = MILLIMETERS ⊗ = HEADSPACE DIMENSION
* DIMENSIONS ARE TO INTERSECTION OF LINES Δ = REFERENCE DIMENSION
ALL CALCULATIONS APPLY AT MAXIMUM MATERIAL CONDITION (MMC)

NOTICE: This drawing is subject to change.
Current version is available at www.saami.org.

MAXIMUM CARTRIDGE / MINIMUM CHAMBER
17 HORNADY MAGNUM RIMFIRE

17 HORNADY MAGNUM RIMFIRE
ISSUED 6/25/02
REVISED 11/28/05

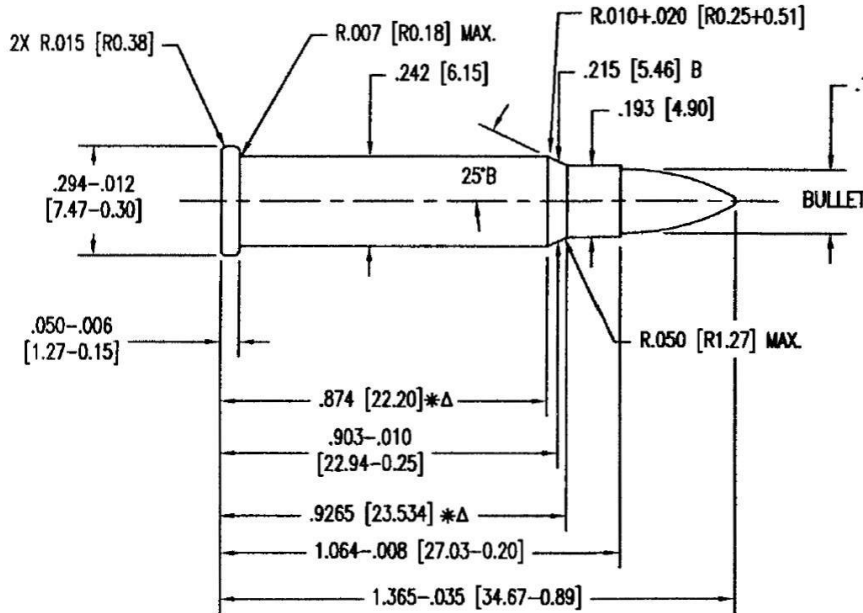

CARTRIDGE
UNLESS OTHERWISE NOTED
BODY DIA. $-.004$ [0.10]

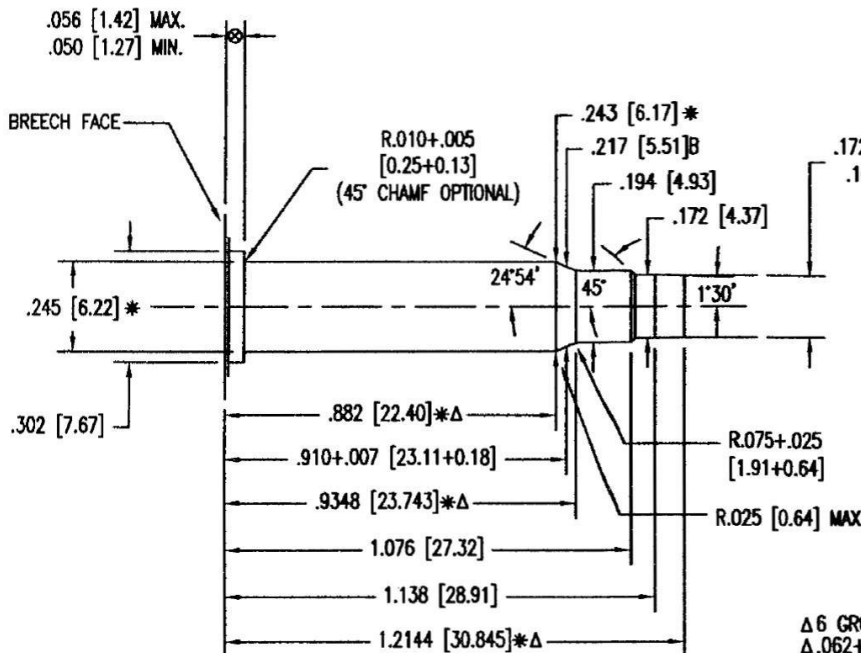

CHAMBER
UNLESS OTHERWISE NOTED
ALL DIA. $+.002$ [0.05]
LENGTH TOL. $+.015$ [0.38]

Δ 6 GROOVES
 Δ .062 $+.002$ [1.57 $+.005$] WIDE
TWIST: 9[228.6] R.H. OPTIONAL
MIN. BORE & GROOVE
AREA: .0229 SQ. IN. [14.774 mm²]

NOTE:
B=BASIC
[XX.XX]=MILLIMETERS
⊗ = HEADSPACE DIMENSION
Δ = REFERENCE DIMENSION
* DIMENSIONS ARE TO INTERSECTION OF LINES
ALL CALCULATIONS APPLY AT MAXIMUM MATERIAL CONDITION (MMC)

NOTICE: This drawing is subject to change.
Current version is available at www.saami.org.

MAXIMUM CARTRIDGE / MINIMUM CHAMBER
17 WINCHESTER SUPER MAGNUM

CARTRIDGE & CHAMBER

17 WINCHESTER SUPER MAGNUM

ISSUED: 07/24/2015

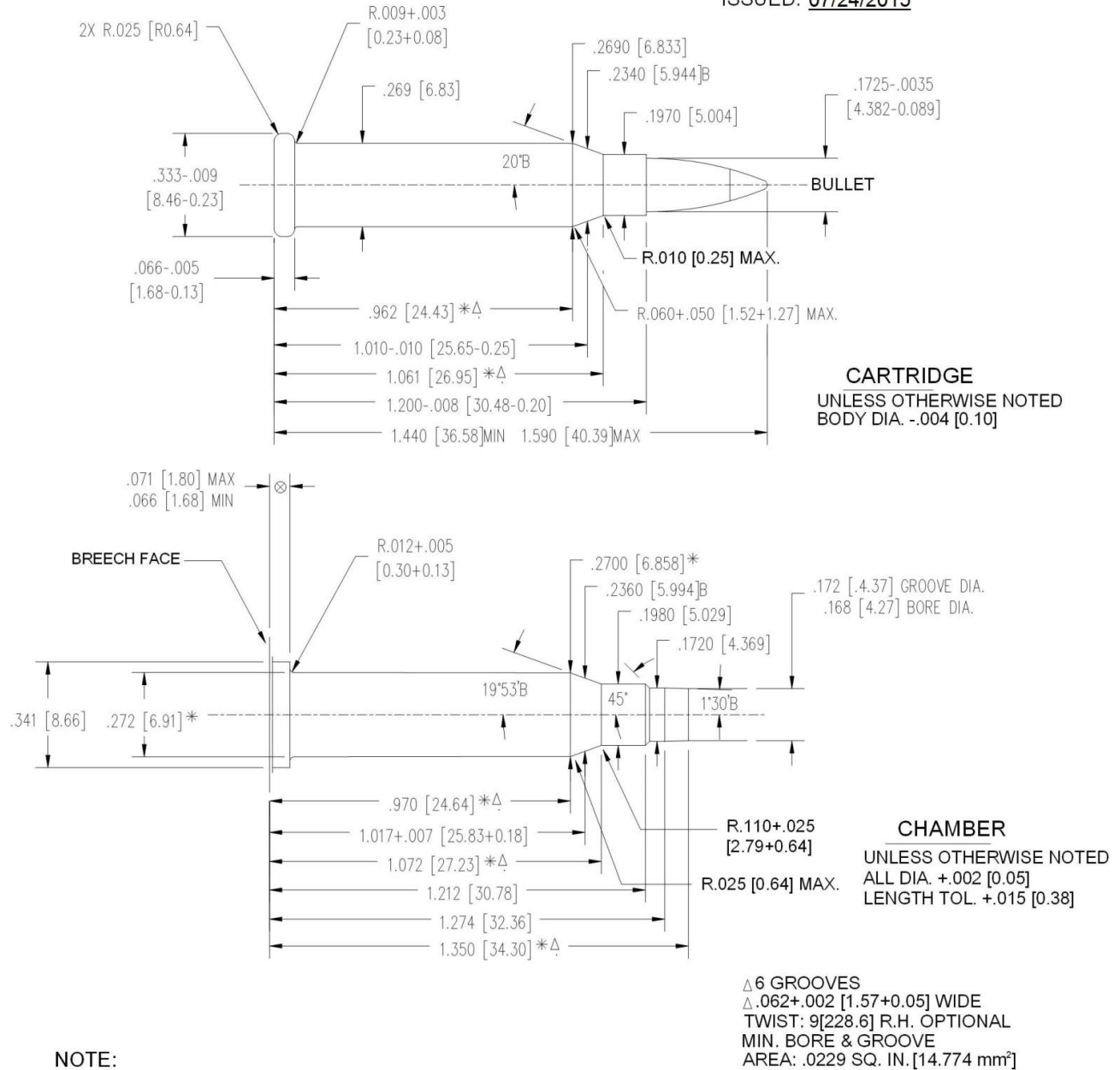

NOTE:
B=BASIC
[XX.XX]=MILLIMETERS
⊗ = HEADSPACE DIMENSION
Δ = REFERENCE DIMENSION
* DIMENSIONS ARE TO INTERSECTION OF LINES
ALL CALCULATIONS APPLY AT MAXIMUM MATERIAL CONDITION (MMC),

NOTICE: This drawing is subject to change.
Current version is available at www.saami.org.

MAXIMUM CARTRIDGE / MINIMUM CHAMBER

22 SHORT

CARTRIDGE & CHAMBER
22 SHORT
22 SHORT CB &
22 SHORT GALLERY
ISSUED SAAMI 5-29-79

CARTRIDGE

UNLESS OTHERWISE NOTED
BODY DIA $-.004$ (0.10)

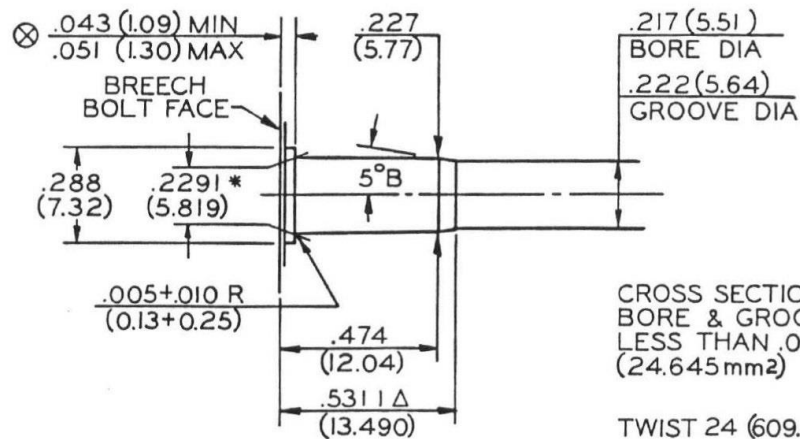
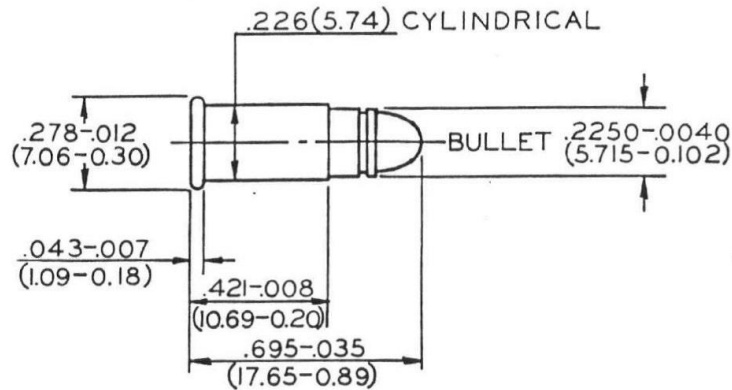

CROSS SECTION AREA OF
BORE & GROOVES NOT
LESS THAN .0382 SQ IN.
(24.645mm²)

TWIST 24 (609.6) RH-OPTIONAL

CHAMBER

UNLESS OTHERWISE NOTED
ALL DIA $+.002$ (0.05)
LENGTH TOL $+.015$ (0.38)

NOTE

B = BASIC

(XX.XX) = MILLIMETERS ⊗ = HEADSPACE DIMENSION

* DIMENSIONS ARE TO INTERSECTION OF LINES. Δ = REFERENCE DIMENSION

ALL CALCULATIONS APPLY AT MAXIMUM MATERIAL CONDITION (MMC)

NOTICE: This drawing is subject to change.
Current version is available at www.saami.org.

MAXIMUM CARTRIDGE / MINIMUM CHAMBER

22 LONG

CARTRIDGE & CHAMBER

22 LONG

ISSUED SAAMI 5-29-79

CARTRIDGE

UNLESS OTHERWISE NOTED
BODY DIA $-.004$ (0.10)

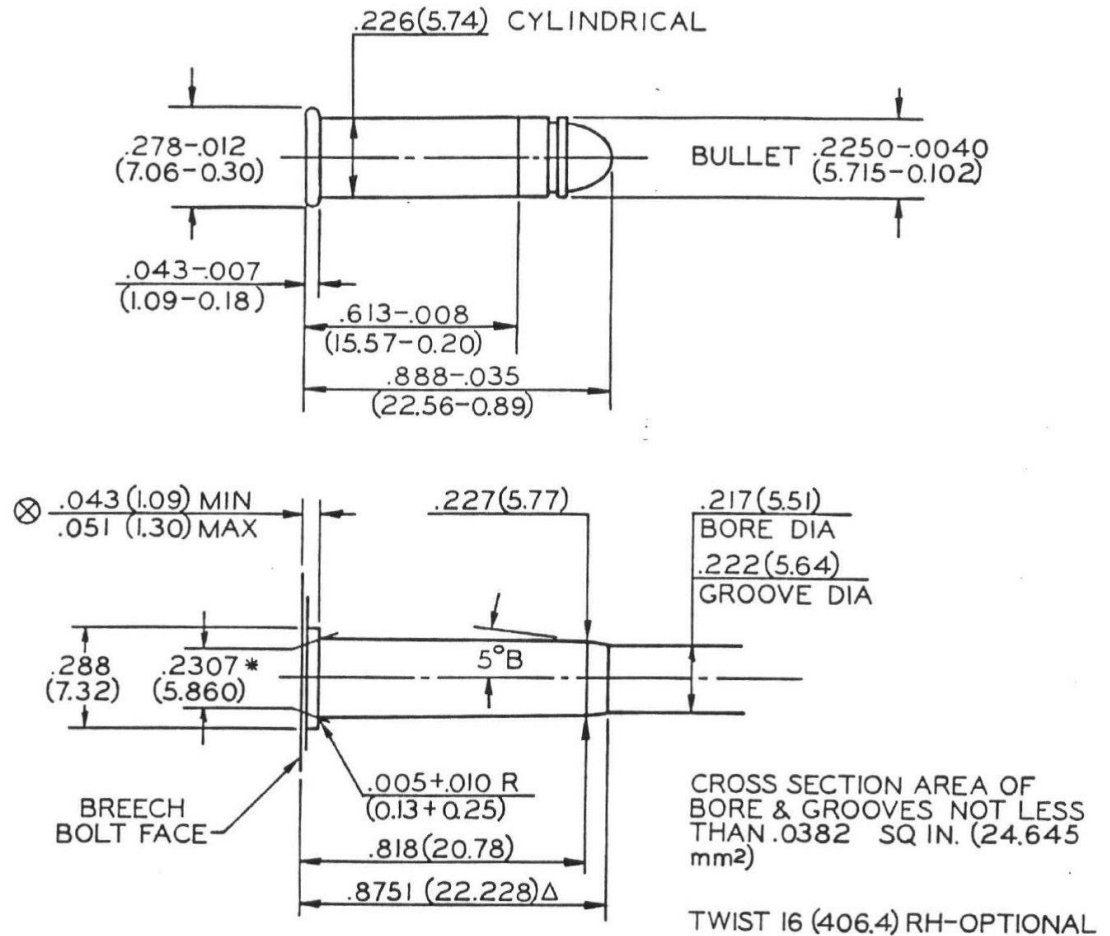

NOTE

B = BASIC

(XX.XX) = MILLIMETERS ⊗ = HEADSPACE DIMENSION

* DIMENSIONS ARE TO INTERSECTION OF LINES Δ = REFERENCE DIMENSION

ALL CALCULATIONS APPLY AT MAXIMUM MATERIAL CONDITION (MMC)

NOTICE: This drawing is subject to change.
Current version is available at www.saami.org.

MAXIMUM CARTRIDGE / MINIMUM CHAMBER

22 LONG RIFLE - MATCH

CARTRIDGE & CHAMBER
22 LONG RIFLE-MATCH
ISSUED SAAMI 5-29-79

CARTRIDGE
UNLESS OTHERWISE NOTED
BODY DIA $-.004$ (0.10)

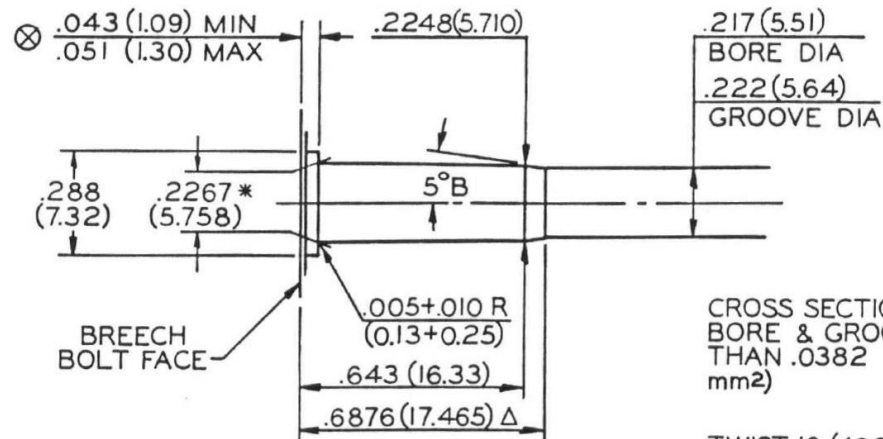
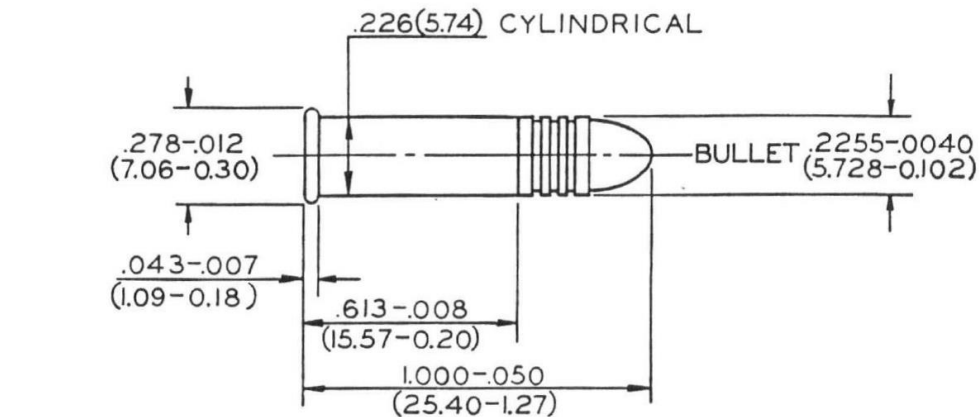

CROSS SECTION AREA OF
BORE & GROOVES NOT LESS
THAN .0382 SQ IN. (24.645
mm²)

TWIST 16 (406.4) RH-OPTIONAL

CHAMBER
UNLESS OTHERWISE NOTED
ALL DIA $+.002$ (0.05)
LENGTH TOL $+.015$ (0.38)

NOTE

B=BASIC

(XX.XX)=MILLIMETERS ⊗=HEADSPACE DIMENSION

* DIMENSIONS ARE TO INTERSECTION OF LINES Δ=REFERENCE DIMENSION
ALL CALCULATIONS APPLY AT MAXIMUM MATERIAL CONDITION (MMC)

NOTICE: This drawing is subject to change.
Current version is available at www.saami.org.

MAXIMUM CARTRIDGE / MINIMUM CHAMBER

22 LONG RIFLE - SPORTING

CARTRIDGE & CHAMBER
22 LONG RIFLE-SPORTING
ISSUED SAAMI 5-29-79

CARTRIDGE
UNLESS OTHERWISE NOTED
BODY DIA $-.004$ (0.10)

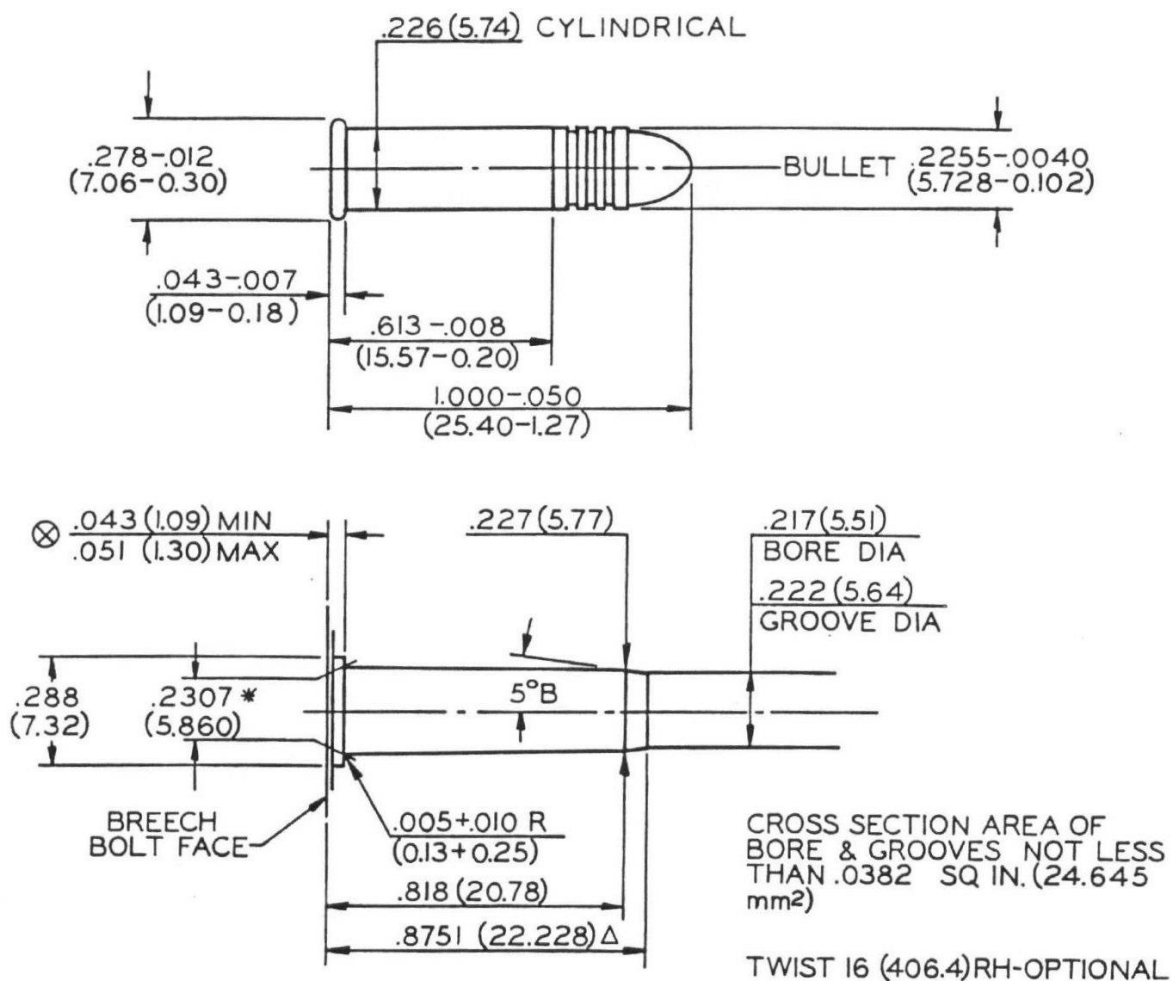

CHAMBER
UNLESS OTHERWISE NOTED
ALL DIA $+.002$ (0.05)
LENGTH TOL $+.015$ (0.38)

NOTE

B = BASIC

(XX.XX) = MILLIMETERS

⊗ = HEADSPACE DIMENSION

* DIMENSIONS ARE TO INTERSECTION OF LINES

Δ = REFERENCE DIMENSION
ALL CALCULATIONS APPLY AT MAXIMUM MATERIAL CONDITION (MMC)

NOTICE: This drawing is subject to change.
Current version is available at www.saami.org.

MAXIMUM CARTRIDGE / MINIMUM CHAMBER

22 LONG RIFLE SHOT

CARTRIDGE & CHAMBER
22 LONG RIFLE SHOT
ISSUED SAAMI 5-29-79

CARTRIDGE
UNLESS OTHERWISE NOTED
BODY DIA $-.004$ (0.10)

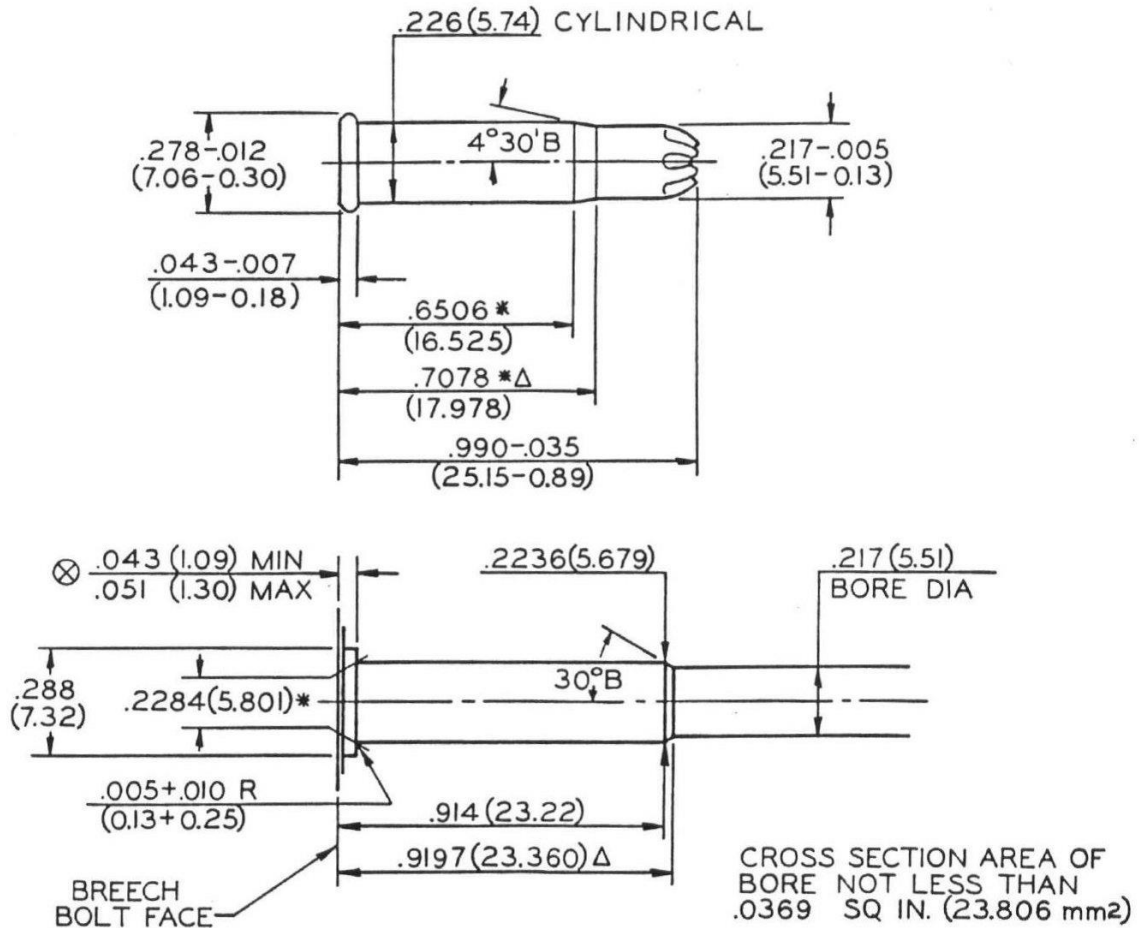

CHAMBER
UNLESS OTHERWISE NOTED
ALL DIA $+.002$ (0.05)
LENGTH TOL $+.015$ (0.38)

NOTE

B = BASIC

(XX.XX) = MILLIMETERS ⊗ = HEADSPACE DIMENSION

* DIMENSIONS ARE TO INTERSECTION OF LINES Δ = REFERENCE DIMENSION

ALL CALCULATIONS APPLY AT MAXIMUM MATERIAL CONDITION (MMC)

NOTICE: This drawing is subject to change.
Current version is available at www.saami.org.

MAXIMUM CARTRIDGE / MINIMUM CHAMBER

22 WINCHESTER RIMFIRE

CARTRIDGE & CHAMBER
22 WINCHESTER RIMFIRE
RE-ISSUED 6/28/06

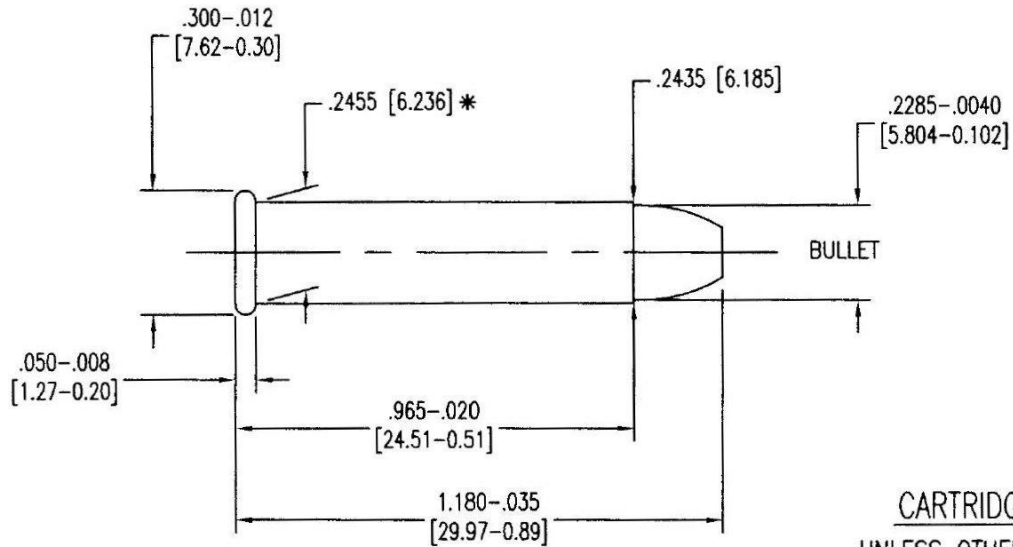

CARTRIDGE

UNLESS OTHERWISE NOTED
BODY DIA. $-.004$ [0.10]

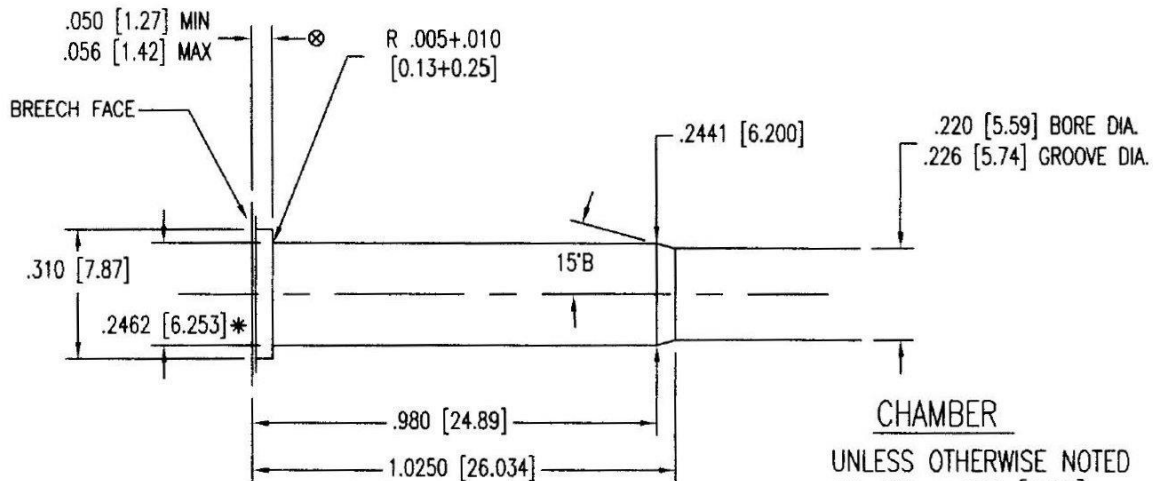

CHAMBER

UNLESS OTHERWISE NOTED
ALL DIA. $+.002$ [0.05]
LENGTH TOL. $+.015$ [0.38]

NOTE:

B=BASIC

[XX.XX]=MILLIMETERS

⊗ = HEADSPACE DIMENSION

Δ = REFERENCE DIMENSION

* DIMENSIONS ARE TO INTERSECTION OF LINES

ALL CALCULATIONS APPLY AT MAXIMUM MATERIAL CONDITION (MMC)

Δ 6 GROOVES

Δ $.075+0.002$ [1.91+0.05] WIDE

TWIST: 14[355.6] R.H. OPTIONAL

MIN. BORE & GROOVE [25.42 mm]²

AREA: .0394 SQ. IN.

NOTICE: This drawing is subject to change.
Current version is available at www.saami.org.

MAXIMUM CARTRIDGE / MINIMUM CHAMBER
22 WINCHESTER MAGNUM RIMFIRE

CARTRIDGE & CHAMBER
22 WINCHESTER MAGNUM RIMFIRE
ISSUED SAAMI 5-29-79

CARTRIDGE
UNLESS OTHERWISE NOTED
BODY DIA $-.004$ (0.10)

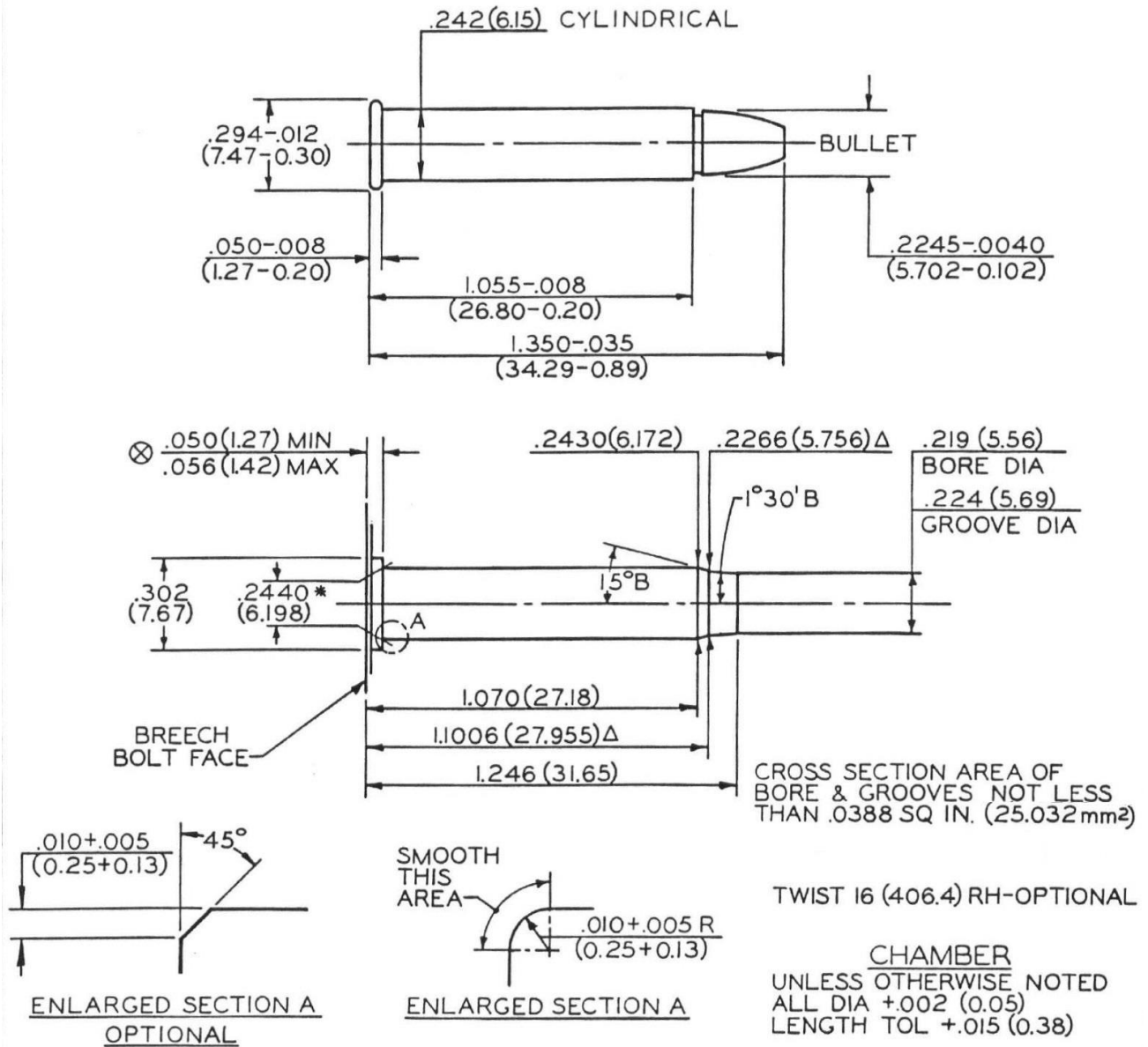

NOTE

B=BASIC

(XX.XX)=MILLIMETERS \otimes =HEADSPACE DIMENSION

* DIMENSIONS ARE TO INTERSECTION OF LINES Δ =REFERENCE DIMENSION

ALL CALCULATIONS APPLY AT MAXIMUM MATERIAL CONDITION (MMC)

DUMMY CARTRIDGE: GUN FUNCTIONING

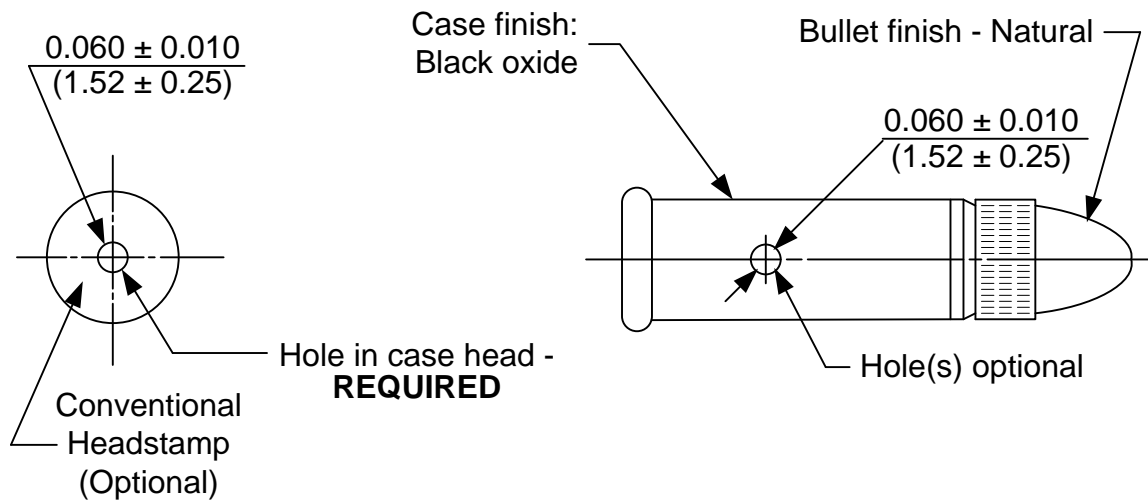

NOTE

Illustrates form only!

Pertinent dimensions shown on appropriate cartridge drawing.

(XX.XX) = millimeters

**DUMMY CARTRIDGE:
DISPLAY**

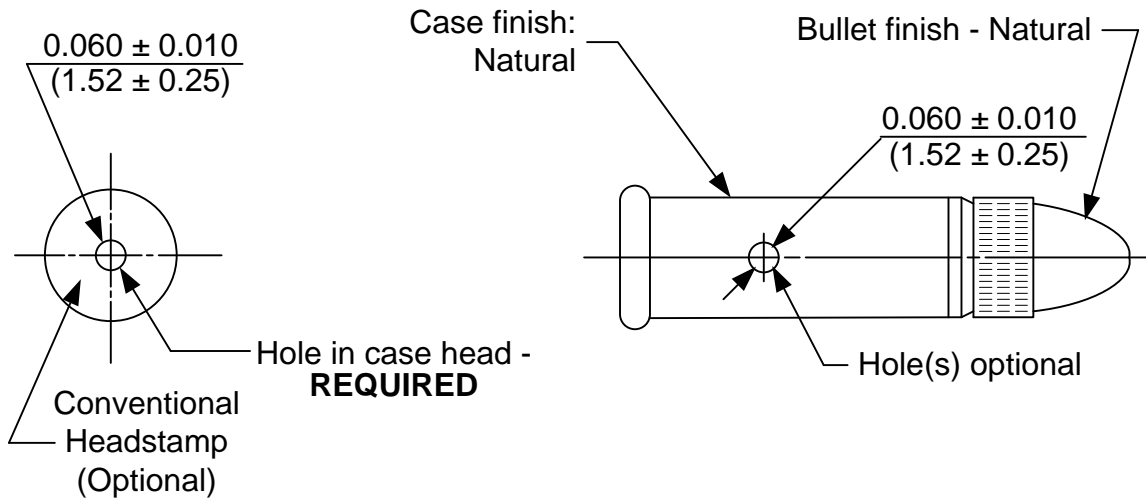

NOTE

Illustrates form only!
Pertinent dimensions shown on appropriate cartridge drawing.

(XX.XX) = millimeters

**HEADSPACE:
17 MACH 2**

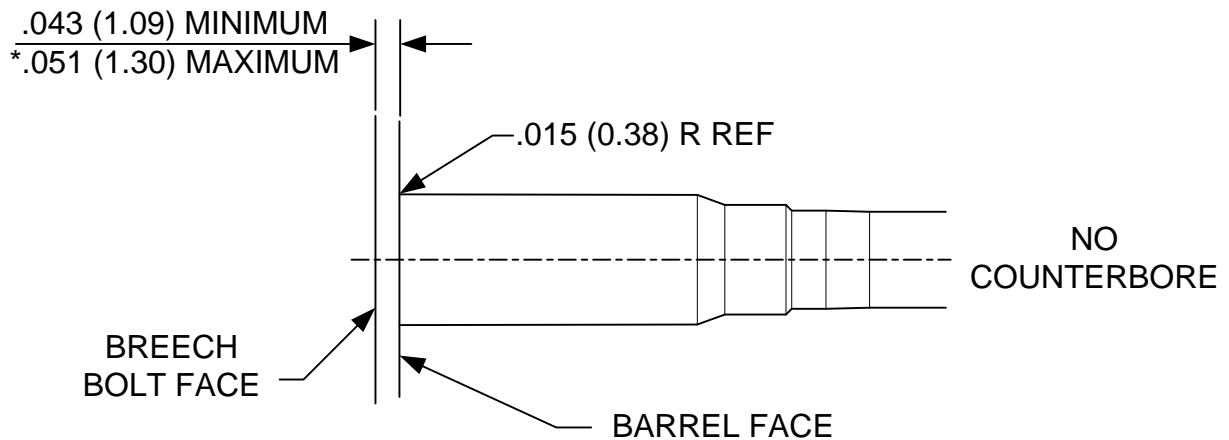
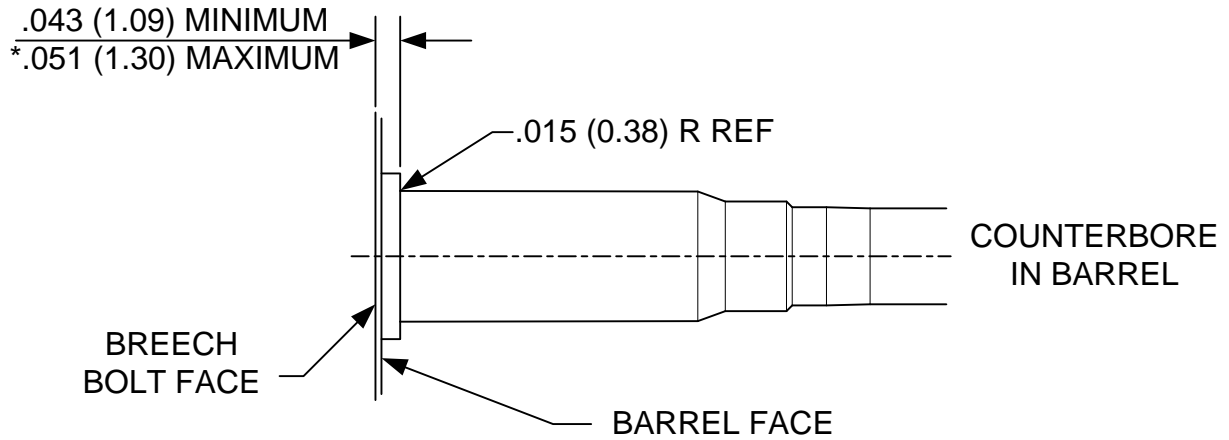
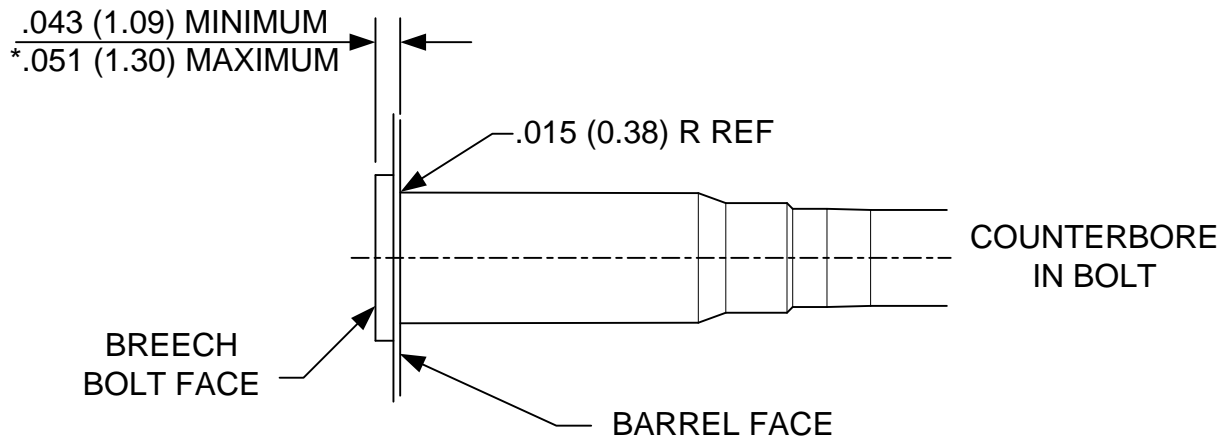

NOTE

* REPRESENTS MAXIMUM ADVISABLE CONDITION AFTER USE.

(XX.XX) = MILLIMETERS

**HEADSPACE:
17 HORNADY MAGNUM RIMFIRE**

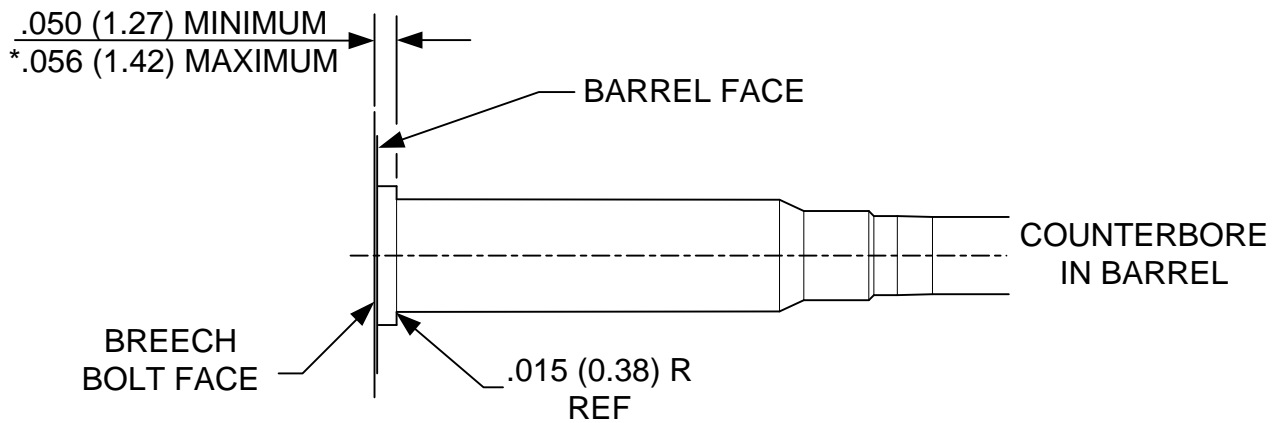
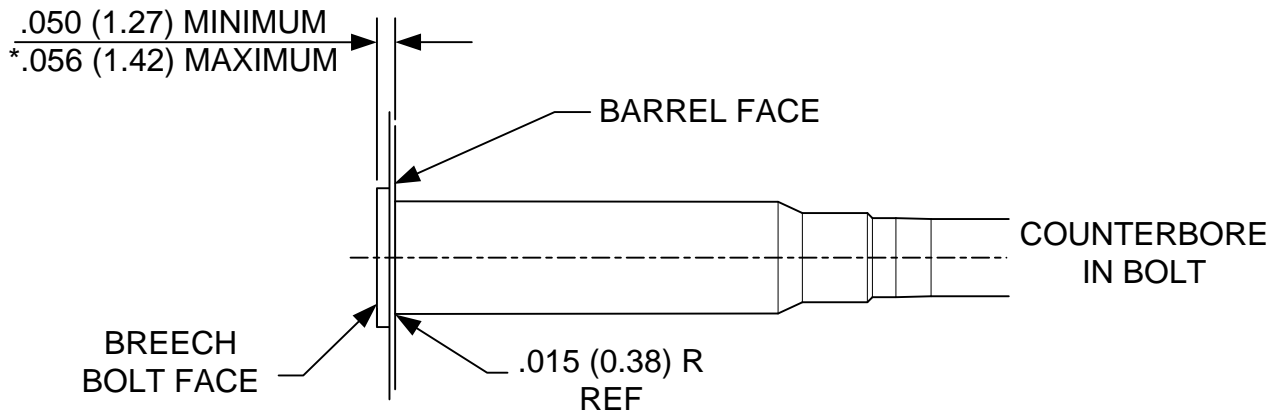

NOTE

* REPRESENTS MAXIMUM ADVISABLE CONDITION AFTER USE.

(XX.XX) = MILLIMETERS

**HEADSPACE:
17 WINCHESTER SUPER MAGNUM**

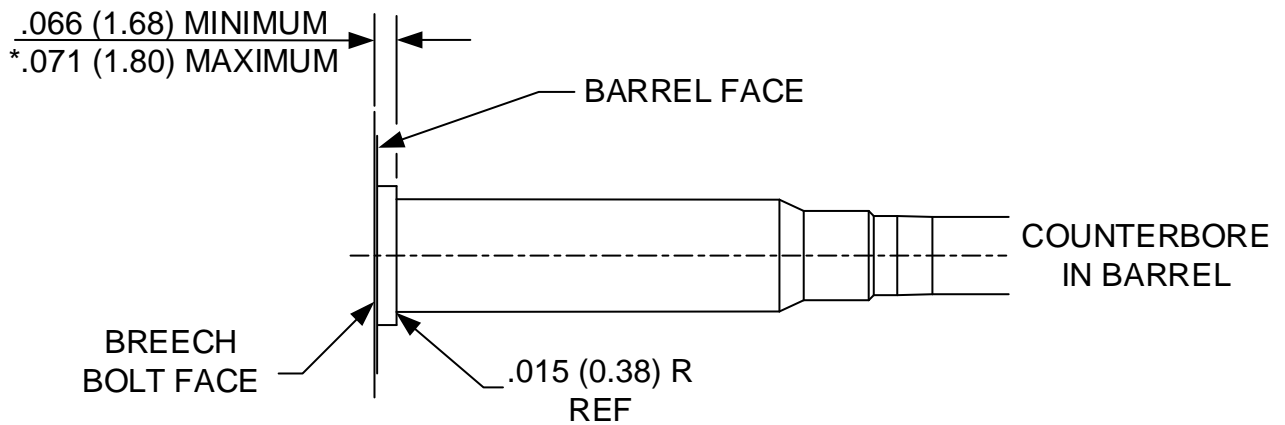
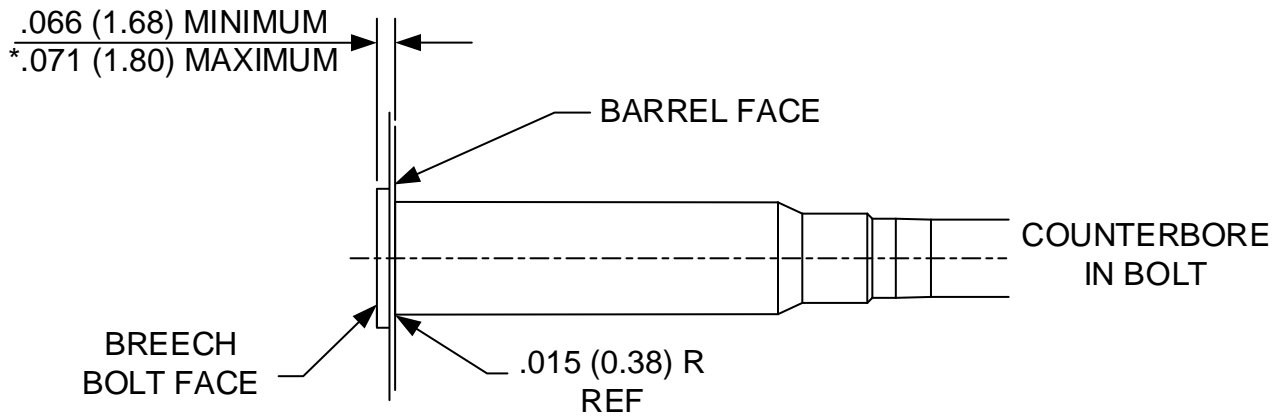

NOTE

* REPRESENTS MAXIMUM ADVISABLE CONDITION AFTER USE.

(XX.XX) = MILLIMETERS

**HEADSPACE:
22 SHORT, LONG, LONG RIFLE, AND LONG RIFLE SHOT**

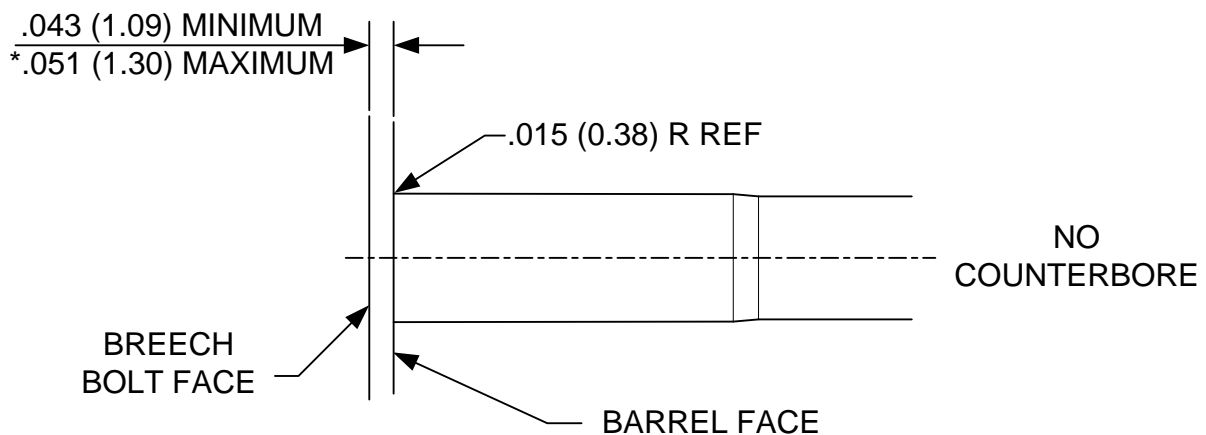
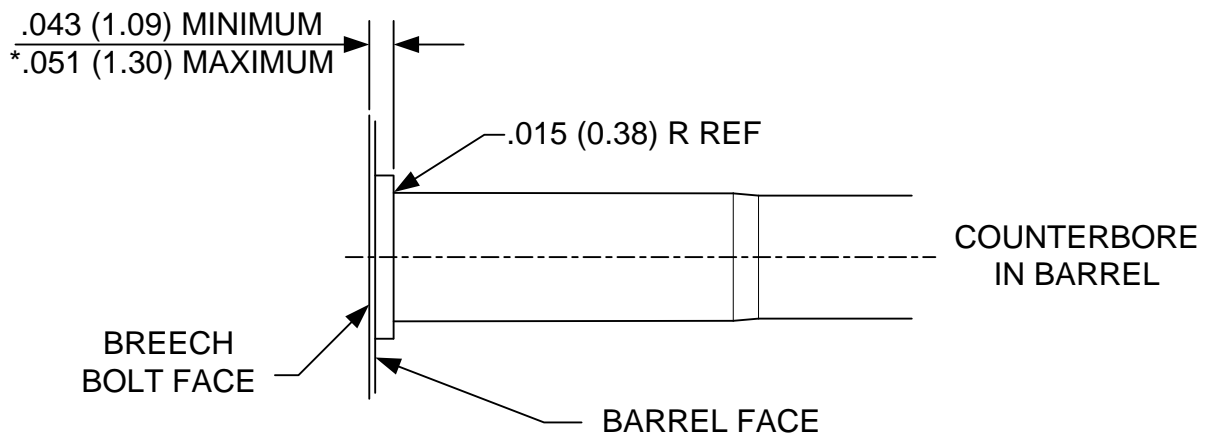
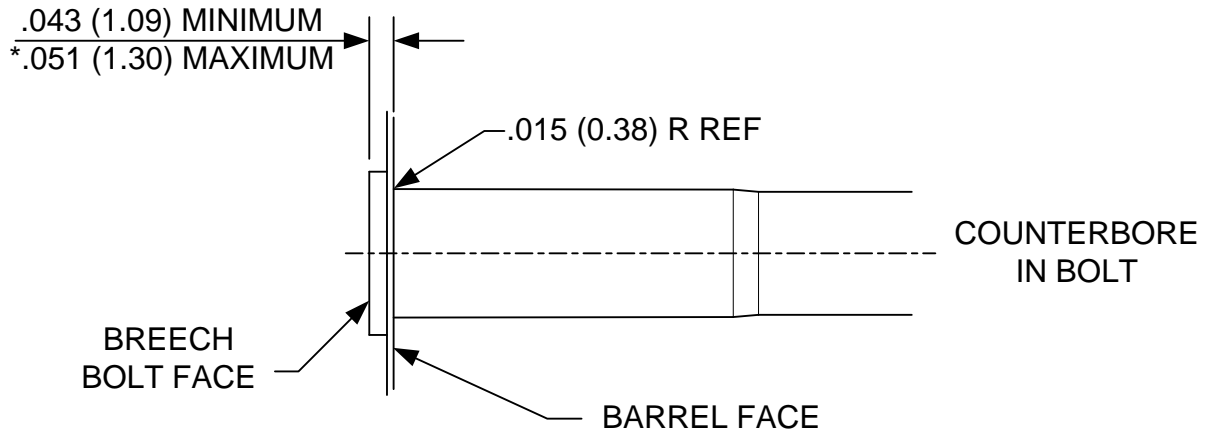

NOTE

* REPRESENTS MAXIMUM ADVISABLE CONDITION AFTER USE.

(XX.XX) = MILLIMETERS

HEADSPACE:
22 WINCHESTER RIMFIRE & 22 WINCHESTER MAGNUM

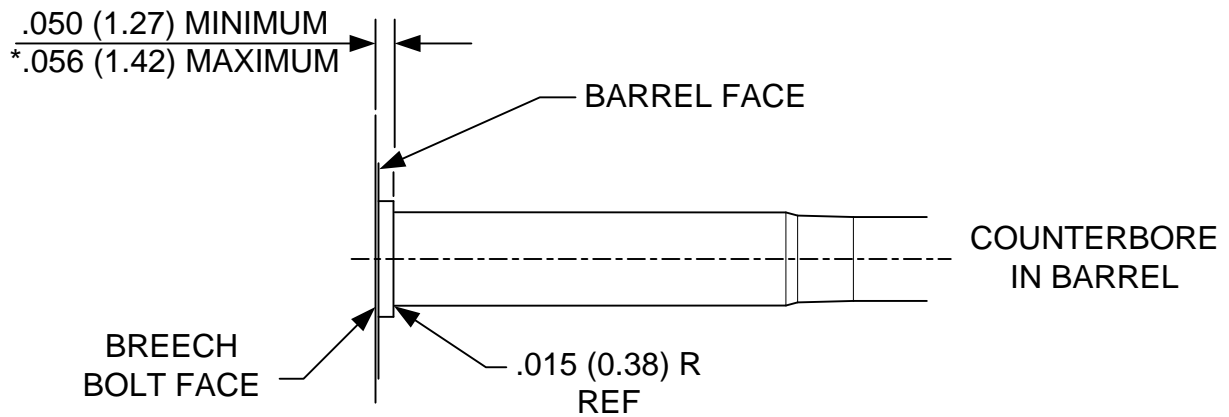
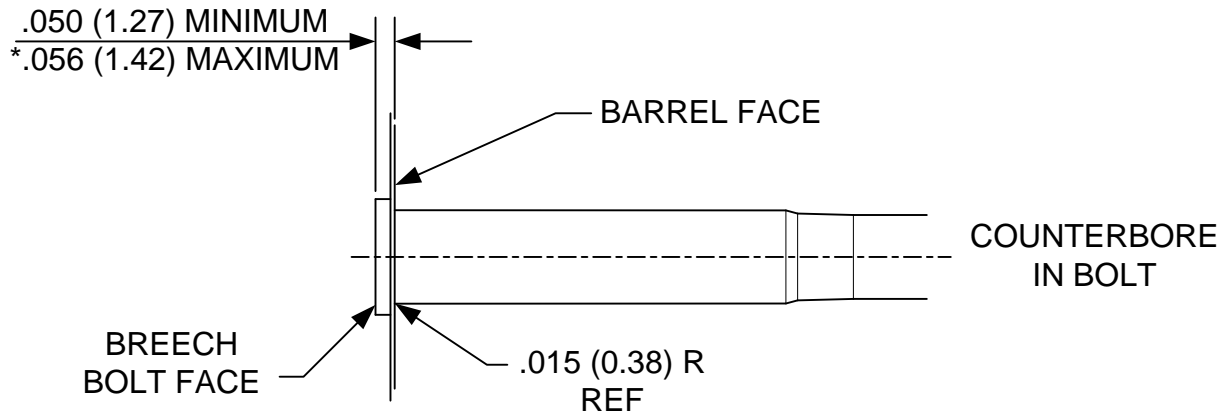

NOTE

* REPRESENTS MAXIMUM ADVISABLE CONDITION AFTER USE.

(XX.XX) = MILLIMETERS

TOLERANCE: BULLET WEIGHT

Nominal weight $\pm 2\%$

VELOCITY & PRESSURE BARRELS: QUALIFICATION

All barrels are not necessarily suitable for use in determining pressure or velocity levels, even though they may conform to the dimensions given on the appropriate Standard Velocity and Pressure Barrel drawing in this Standard. New barrels may require a number of rounds to be fired to remove sharp corners or burrs resulting from the manufacturing process. Barrels in service do not have an unlimited life and may become unserviceable from wear and erosion. There is no predictable number of rounds to which a barrel should be exposed before use for pressure and velocity determinations, nor is there a predictable round life for such equipment.

The following procedure is suggested for determining the suitability of any barrel for pressure and velocity test use:

Fire ten (10) rounds of SAAMI Reference Ammunition following the procedures as shown in this Standard. The average velocity and pressure results of the test should be within the Inclusion Limits as given on the latest assessment of the lot fired.

In the case of a new barrel, the firing of more breaking-in shots may be indicated after which the Reference Ammunition test should be repeated.

In the case of barrels which have been in service, removal of fouling or other corrective procedures may be implemented followed by a retest.

VELOCITY & PRESSURE BARRELS: MOUNTING IN RECEIVERS

It is essential that close headspace be maintained in velocity-pressure testing equipment if reliable test results are to be achieved.

In mounting test barrels to Universal Receivers or test actions, a headspace not exceeding 0.003” (0.07 mm) over minimum should be maintained. This may be measured by headspace gages, shim stock or feeler gages, or a combination thereof whichever is most appropriate for the type of equipment being used.

Headspace adjustments with the Universal Receiver may be accomplished by several methods:

- I. Formed shim stock behind the firing-pin plate.
- II. Formed shim stock on the rear bearing shoulder of the Barrel Collar.
- III. Adjustment of the Breech Block Locking Screws.

VELOCITY & CONFORMAL PIEZOELECTRIC PRESSURE TESTING

I. TEST EQUIPMENT

A. TRANSDUCER CALIBRATION

<u>ITEM</u>	<u>TYPE</u>	<u>ALTERNATE</u>
1. Digital Voltmeter	Fluke, Model 8440	or equivalent
2. Charge Amplifier	PCB, Model 443B02	or equivalent
3. Transducer Calibrator (Direct fluidic calibrator)	PCB Group; The Modal Shop, Inc.; Model K9905D	or equivalent
4. Insulation Tester	Kistler, Model 5491	or equivalent
5. Transducer	PCB, Model 117BXX	or equivalent
6. Low Noise Cable	PCB, Model 003AXXX	or equivalent
7. Calibration Adapter	PCB, Model 090B Series	or equivalent

B. FIRING TEST

<u>ITEM</u>	<u>TYPE</u>	<u>ALTERNATE</u>
1. Charge Amplifier	PCB, Model 443B02	or equivalent
2. Voltmeter, Peak Capture	PCB, Model 444A152	or equivalent
3. Transducer	PCB, Model 117BXX	or equivalent
4. Low Noise Cable	PCB, Model 003AXXX	or equivalent
5. Integrated Data Acquisition System	Oehler Research, Inc. System 85	or equivalent

II. EQUIPMENT PREPARATION

- A. All instruments should be operational and calibrated per manufacturer specification.
- B. The transducer calibrator and instruments used to calibrate the charge amplifier, peak detector and digital voltmeter should have a certified calibration traceable to the National Institute of Standards and Technology.
- C. Transducers should be properly maintained per manufacturer recommendations or stored in a desiccator when not in use.

CAUTION: When not in use, the cable, transducers, and instrument connectors should be stored with plastic caps in place to prevent contamination.

- D. Measure the internal resistance of the transducer and low noise cable. If the resistance is less than 10^{12} ohms, bake-out transducer and low noise cable as described in subpart III. B., Transducer Initialization, of this procedure. If the resistance is in the 10^{12} to 10^{14} ohm range, proceed to Section IV, Transducer Calibration.

III. TRANSDUCER INITIALIZATION

- A. Clean transducer and low noise cable connectors using an acceptable solvent per the manufacturer's recommendations.
- B. Bake-out transducer and low noise cable in a temperature controlled oven for 24 to 48 hours at 250°F (121°C).
- C. Allow oven to return to ambient temperature at a slow rate.
- D. After removing the transducer and cable from the oven, check the internal resistance of the transducer. The resistance should be in the 10^{12} to 10^{14} ohm range.
- E. Place protective caps on transducer and cable connectors to prevent contamination.

IV. TRANSDUCER CALIBRATION

A. INITIAL SET-UP

1. Turn on the electronic equipment and allow it to stabilize as recommended by the manufacturer.
2. Inspect the transducer mounting cavity to assure that the seal seat is free of dirt and any other foreign matter.
3. Mount transducer with steel spacer rings into calibration fixture as described in PCB Operating Instructions Manual.
4. Loosen, but do not remove, the slotted clamp.
5. Thread the transducer into the mounting port. Adjust the slotted clamp to allow guide pin to enter guide hole. Continue to turn transducer nut into the mounting port. When transducer bottoms, tighten the slotted clamp and torque the transducer as recommended by the manufacturer.
6. It is essential that the sensing surface of the transducer be flush with the chamber inside diameter. Care must be exercised to obtain correct depth as well as exact rotational alignment. Depth adjustment is accomplished by the use of various thickness spacers. In order to set the depth exactly it may be necessary to hone the spacers to the desired thickness.
7. Mount calibration adapter with transducer on the calibrator.
8. Insert the cartridge case with an inert or fired primer into calibration adapter and complete fixture assembly as per PCB instruction manual. If the sample cartridge is a loaded round, it may be disassembled, the powder removed, and the primer in the empty case then fired.
9. Connect transducer and instrumentation as indicated on page 37.
10. Set the charge amplifier sensitivity to 0.999 and set the time constant switch to LONG.

11. Set DVM to 10-volt range.

B. CALIBRATION

1. Adjust the pressure readout indicator of the transducer calibrator to 0 psi with no pressure on hydraulic lines.
2. Insert a new cartridge case.
3. Reset charge amplifier and digital voltmeter (DVM) to obtain zero volts output.
4. Apply pressure in increments of 3K psi. Calibration pressure range should be from 15K psi to 30K psi. DO NOT exceed the maximum pressure established by the manufacturer for the fixture.
5. Record DVM reading after the pressure readout indicator is exactly at desired pressure level. Do not release the pressure until the highest pressure level, for the cartridge under test, has been reached. Read the pressure at each increment. Do not overshoot the pressure points!
6. After reaching the highest calibration pressure level, release the pressure slowly.
7. Replace the cartridge case in calibration adapter.
8. Repeat steps 1 through 7 until a minimum of ten valid data points are obtained.

CAUTION: Always increase pressure to desired level; never decrease pressure to desired level.

9. Transducers need to be re-calibrated when changing brands of ammunition or if there have been changes in cartridge case processes and/or material.

C. DATA REDUCTION

1. Calculate the average value for the output voltages recorded at each pressure increment. Multiply these average values by the charge amplifier sensitivity (pC/V) to obtain the transducer charge output (Q) at these pressure increments (P).
2. Obtain a least square line equation using the transducer charge output (Q) as the dependent variable and pressure (P) as the independent variable. $Q = mP \pm q$.
3. A manual method of calculating the least square line equation is given in tabular form on page 38. It is recommended that when using this technique, all numbers be carried to the third decimal place.
4. Obtain the pressure (P) offset value when Q in the line equation is zero. Refer to pages 38ff.

D. CALIBRATION CHECK

When the calibration calculations are complete the sensitivity should be set on the charge amplifier. The digital voltmeter is set at zero. A new sample cartridge is put in the calibration fixture and the hydraulic pressure increased to the highest pressure reached in the calibration. The digital voltmeter reading plus the offset should equal the hydraulic gauge reading. Check calibration again by inserting a second cartridge. As a guideline, these values should agree within $\pm 1.5\%$ of the gauge reading. If the transducer does not meet this guideline then recheck the calculations and/or recalibrate.

E. TRANSDUCER RECORDS

1. Date of calibration
2. The number of rounds to which the transducer has been exposed during test firing.
3. Calibration pressure (P), charge amplifier voltage output (V), and transducer charge output (Q).
4. Charge amplifier sensitivity.
5. Least square line equation.
6. Pressure offset, and transducer sensitivity (slope = m).
7. Transducer identification.
8. Date of next calibration.

V. FIRING TEST

- A. Velocities and pressures should be measured in horizontally-mounted test barrels of the appropriate caliber and length for the cartridges to be tested.
- B. Recommended values for velocity and pressure of all rimfire cartridges are tabulated on pages 6ff. When required, a minimal retest of double the original quantity may be fired with statistically equivalent tolerances.
- C. Drawings and descriptions of the required equipment are listed in Section III of this volume.

D. PRESSURE BARREL PREPARATION

1. Refer to the SAAMI recommended piezo pressure transducer installation in a pressure barrel illustrated in Section III.

E. INITIAL SET-UP

1. Turn on the electronic equipment and allow to stabilize as recommended by the manufacturer.

2. Inspect the transducer mounting cavity in the pressure barrel to assure that the seal seat is free of dirt and any other foreign matter.
3. Mount transducer with steel spacer rings into the test barrel as described in PCB Operating Instructions Manual.
4. Loosen, but do not remove, the slotted clamp.
5. Thread the transducer into the mounting port. Adjust the slotted clamp to allow guide pin to enter guide hole. Continue to turn transducer nut into the mounting port. When transducer bottoms, tighten the slotted clamp and torque the transducer as recommended by the manufacturer.
6. It is essential that the sensing surface of the transducer be flush with the chamber inside diameter. Care must be exercised to obtain correct depth as well as exact rotational alignment. Depth adjustment is accomplished by the use of various thickness spacers. In order to set the depth exactly it may be necessary to hone the spacers to the desired thickness.
7. Connect equipment as shown in pages 40 and/or 41.

NOTE: Configurations 1 and 2 are interchangeable.

IMPORTANT: Always switch the OPERATE-GND switch to the “GND” position before making connections to the charge amplifier and allow switch to remain in this position during such connections. This protects the FET input stage against possible gate damage from excessive accumulated static charge.

8. Set the charge amplifier controls for short time constant, transducer sensitivity to the slope (m) obtained from the transducer least square line equation and set the GROUND/OPERATE switch to the OPERATE position.
9. Select digital peak meter, positive input, peak mode, and 10-volt range.
10. Take note of the transducer offset value (P) obtained from the least square line equation. This value will be used later in making final peak pressure determination.
 - 10.1 The offset value may also be dialed into an instrumentation system capable of providing direct peak pressures without data manipulation.

F. PROCEDURE

1. Reset all pressure instrumentation and assure that the peak meter digital display reads all zeros. Test rounds may now be fired.
2. For each round fired, the pressure reading on the digital display should be recorded and pressure instrumentation reset.
3. **Handling of Ammunition (Rotation Optional)**

- 3.1 Cartridges to be tested should be placed in a vertical position with primer-end down in a recessed holding block.
 - 3.2 When the appropriate test barrel has been properly serviced and the chronograph reset, a cartridge should be lifted vertically from the block. It should be rotated slowly, end over end, in a vertical plane through 360° pausing momentarily when the powder is at the bullet end and again when the powder is at the primer end.
 - 3.3 The cartridge is then rotated slowly, a minimum amount to enter the chamber, keeping the primer end in the lowest possible position until inserted gently and carefully into the chamber.
 - 3.4 The cartridge should be seated in the chamber as far as practicable with the fingers. The bolt or breech mechanism should be closed gently in order not to disturb the position of the powder in the cartridge case. The object of this method of handling cartridges is to position the propellant powder at the primer end of the cartridge case by permitting it to fall gently against the primer while rotating the case.
 - 3.5 The rate of fire should not be rapid enough to cause excessive heating of the barrel. The time between rounds depends on the equipment, as the barrel may be cooled by a constant stream of air on the outside or by directing air through the bore after each ten rounds.
 - 3.6 Special conditioning is not required.
4. Two warming shots should be fired before firing each series for record. The velocity and/or pressure of these shots may be recorded, but should not be included in the record of the sample.

G. PEAK PRESSURE DETERMINATION

1. To determine peak pressures, add as required, the pressure offset value to the pressure readings obtained in the firing test. Adding the offset value is not required if it is dialed in on the peak meter.

H. VELOCITY DETERMINATION

1. Handling of the ammunition should be in accordance with the instructions in section F (3). The time of flight of the bullet should be measured with a 100 kilohertz (minimum) electronic counter chronograph using photoelectric screens spaced 20 feet (6.10 m) apart with the first screen 5 feet (1.52 m) and the second 25 feet (7.62 m) from the muzzle of the test barrel. See page 56 for a schematic layout of the velocity screens.
2. A table of time of flight vs. velocity should be used to determine instrumental velocity at 15 feet (4.57 m) from the gun muzzle (not required when using direct reading equipment).
3. It is recommended that a blast shield be positioned between the muzzle of the Universal Receiver barrel and the first velocity screen to eliminate the possibility of premature

- triggering of the velocity screens. With velocities below the speed of sound, the muzzle blast and/or muzzle flash will reach the screen before the bullet and may cause premature triggering of the first screen. For example, premature triggering of the first screen will result in abnormally low velocity readings. Premature triggering of both screens will result in a velocity reading that corresponds to the speed of sound.
4. The blast shield should be of rigid, opaque material of sufficient strength to withstand the shock wave but not be resistant to the passage of the projectile.

I. RECORDING OF TEST RESULTS

1. The following data should be recorded for each series of shots fired for velocity and pressure.
 - i) Ammunition Data
 - (1) Date of test
 - (2) Nominal cartridge identification
 - (3) Cartridge caliber
 - (4) Bullet weight and type
 - (5) Powder charge, type, and lot
 - (6) Priming
 - (7) Type of lubricant (if any)
 - (8) Code or date of loading
 - ii) Average velocity, uncorrected.
 - iii) Average pressure, uncorrected.
 - iv) Maximum and minimum individual velocity.
 - v) Maximum and minimum individual pressure.
 - vi) Extreme variation (range) of velocity.
 - vii) Extreme variation (range) of pressure.
 - viii) Other statistical indication of variation (optional).
 - ix) Correction to results from firing Reference Ammunition (optional).
 - x) Corrected average velocity (optional).
 - xi) Corrected average pressure (optional).
 - xii) Recommended values
 - (1) Average velocity
 - (2) Average pressure
 - (3) Velocity and pressure variation

- xiii) Test firearm and range data
 - (1) Barrel length and serial number
 - (2) Barrel history
 - (3) Type of chronograph and screens
- xiv) Test personnel.

J. USE OF REFERENCE AMMUNITION

1. Purpose

- (1) Reference ammunition, assessed by firings at the ranges of member companies, is available for calibrating ranges, firearms and other equipment for velocity and pressure only.

2. Supply

- (1) On request, the SAAMI Technical Office¹ will supply information on the manufacturer of specific Reference Ammunition. The method of identifying Reference Ammunition is shown in Section II.
- (2) Requests for Reference Ammunition should be addressed to the manufacturer of the specific cartridge.

3. Assessment

Details of the assessment tests are shown in Section II.

4. Clearing House

Results of assessment tests of Reference Ammunition are tabulated, analyzed and distributed by the SAAMI Technical Office.

5. Corrections

For method of applying corrections to tests of service loads see Section II.

¹ Refer to page 54 for contact information for the SAAMI Technical Office.

**TRANSDUCER CALIBRATION:
EQUIPMENT INTERCONNECTION**

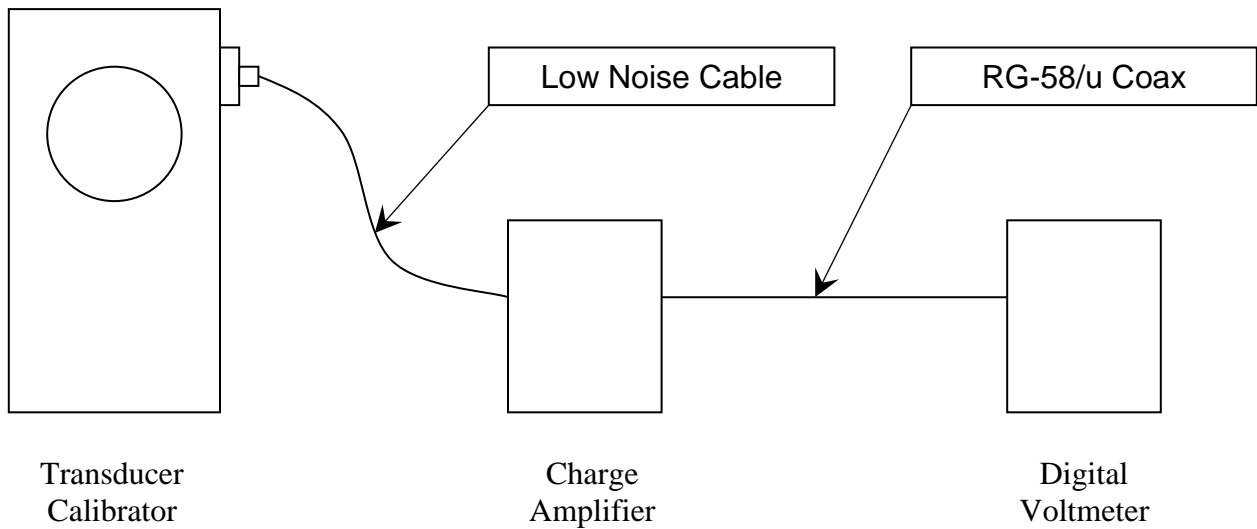

Figure 2

**TRANSDUCER CALIBRATION:
LEAST SQUARE LINE COMPUTATION**

$$Q = mP + q$$

$$m = \frac{\sum(PQ) - \frac{\sum P \sum Q}{n}}{\sum P^2 - \frac{(\sum P)^2}{n}} \quad q = \frac{\sum P \sum(PQ) - \sum(P^2) \sum Q}{(\sum P)^2 - n \sum P^2}$$

Where:

n = Number of data points.

Q = Charge, in picocoulombs, pC.

m = Slope ($\Delta Q/\Delta P$); transducer sensitivity in pC/psi.

P = Pressure, in pounds per square inch, psi.

q = Charge intercept, in picocoulombs, pC.

V = Average output voltage at the indicated pressure, in volts, v.

S = Charge amplifier sensitivity.

$$Offset = \frac{q}{m}$$

	P	S	V	Q (SV)	(PQ)	P ²
TOTAL	$\Sigma P =$			$\Sigma Q =$	$\Sigma(PQ) =$	$\Sigma(P^2) =$

Figure 3

OUTPUT vs. PRESSURE

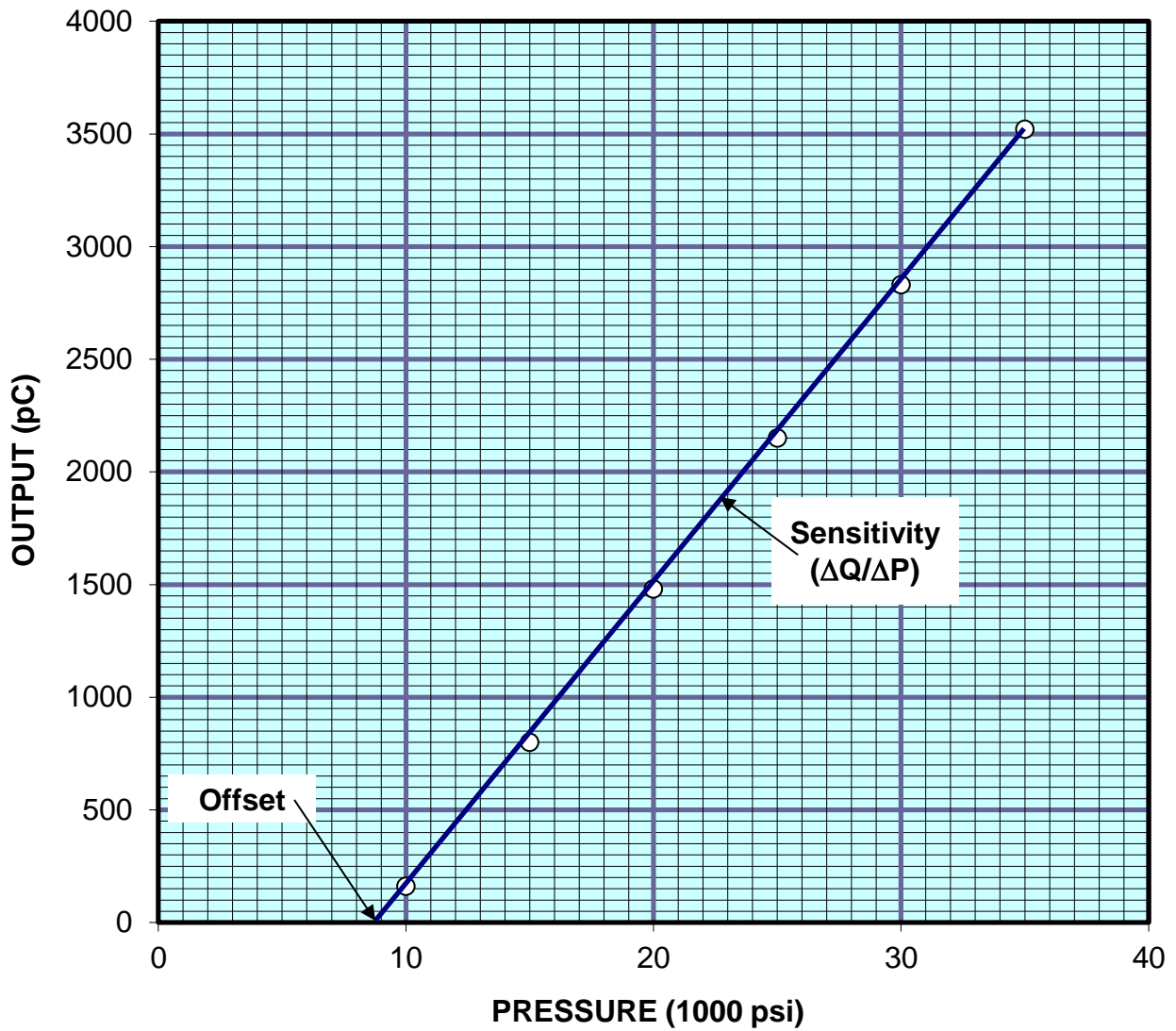

Figure 4

**FIRING TEST:
EQUIPMENT INTERCONNECTION**

Configuration 1

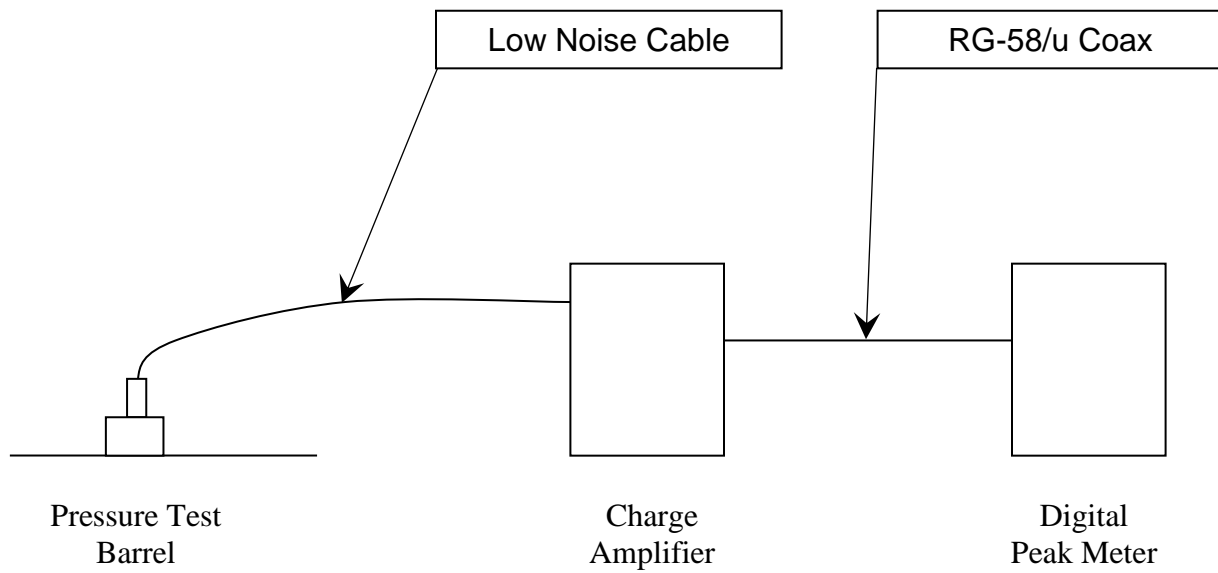

Figure 5

**FIRING TEST:
EQUIPMENT INTERCONNECTION (cont'd)**

Configuration 2

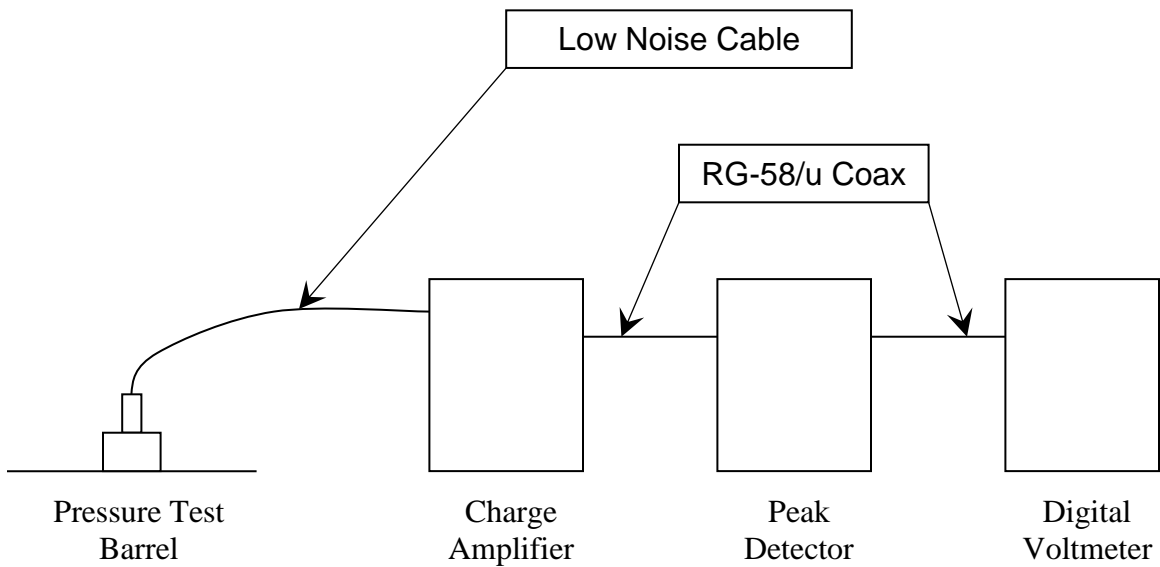

Figure 6

REFERENCE AMMUNITION: USE

A. PURPOSE

Reference Ammunition is for the purpose of relating pressure and velocity test results at all ranges.

B. PROCUREMENT

Reference Ammunition is procured as noted on pages 75ff.

C. USE

The use and usefulness of Reference Ammunition in connection with the testing of ammunition for velocity and pressure is predicated upon two basic assumptions as follows:

1. Associated with a given batch of Reference Ammunition at a given time is an assessed average velocity, an assessed average pressure, as well as upper and lower limits for each, which the averages of any ten round test may be expected to fall within when:
 - a. The reference ammunition manufacturer has applied appropriate safeguards to ensure homogeneity of the lot.
 - b. The ammunition is tested only after being conditioned under controlled temperature and humidity.
 - c. The ammunition is tested in equipment compliant with Section III recommendations.
 - d. The ammunition is handled in strict accordance with Section II recommendations.
 - e. All auxiliary measuring equipment has been set up in accordance with Section II recommendations and is in proper working condition.
2. Although there will be changes over time in the velocity and pressure assessments, the changes occur sufficiently slowly to be detected by periodic reassessments before they have achieved a magnitude sufficient to impair the usefulness of the reference rounds. In other words, the velocity and pressure assessments are reasonably stable with time.

The average velocity and pressure that may be developed by a sample of Reference Ammunition in any given standard test barrel under given test conditions may be different from the results obtained under the test conditions referred to above in assumption 1 due to minor equipment variations and statistical sampling error. Such values may be perfectly real, providing the auxiliary equipment introduces no errors.

In order to realize the benefits of Reference Ammunition, some rules must be adhered to. Nevertheless, each individual user must make the final judgments concerning how often it is used and the use of the data. It is important, therefore, that there be a clear realization of what it can and what it cannot tell the ammunition tester.

Reference Ammunition cannot guarantee the absolute accuracy of any test system. It does, however, provide simple and direct data from any given ammunition test equipment to determine how closely it relates to the acceptable, average system as used by SAAMI members.

In line with the preceding discussion, the following recommendations are made for the use of Reference ammunition:

- A. Each Reference Lot should be conditioned before use.
- B. How often Reference Ammunition is used shall be determined by the user's internal practices, taking into account such factors as historical knowledge of barrel life.
- C. The recommended minimum sample shall be ten rounds.
- D. In the event the observed average velocity and pressure of the sample falls within the *Inclusion Limits*, a correction may or may not be applied according to the procedure given in Step G at the discretion of the user.
- E. If one average is outside of the *Inclusion Limits* and the other within, the average that exceeds the limits shall be corrected according to the procedure given in Step G.
- F. If both averages are outside of the *Inclusion Limits*, both the velocity and pressure shall be corrected according to the procedure in Step G.
- G. If the correction is to be applied, the correction shall be the difference between the assessed value and the observed average of the test.

**REFERENCE AMMUNITION:
SECONDARY REFERENCE AMMUNITION**

Occasionally, a test station will have a need for an inordinately large supply of Reference Ammunition in considerable excess to the usual volume. In order to minimize the premature exhaustion of any particular lot, it is suggested that the station create its own secondary reference lot to fill the special need.

A secondary reference lot should consist of a supply of off-the-shelf ammunition, each box bearing the same manufacturer's code name. The secondary reference lot should be approximately equivalent in bullet weight, average velocity, and average pressure to the Reference Ammunition that it replaces.

REFERENCE AMMUNITION: NEW LOTS

I. GENERAL

Reference Ammunition lots have been established for those lots or loads designated by the SAAMI Technical Committee. Responsibility for production of each of the selected lots is assigned to a member company that is responsible for maintaining a supply. A five-year supply is recommended. It is desirable that Reference Ammunition be consistent with Standard values for that particular round.

When a producer has prepared a new lot, it shall be his responsibility to announce the lot to the SAAMI Technical Office², giving a tentative assessment and other data. (An example of the recommended format for this announcement appears later in this section.)

The producer shall supply, at the time of the announcement of the new lot, to each member of the Reference Ammunition Group that has the capability to test that cartridge, one box of the new lot for immediate test. A current list of the testing capabilities of the Reference Ammunition Group is available from the SAAMI Technical Office on request.

The SAAMI Technical Office will announce the availability of the new lot to the participating ranges, giving the tentative assessment and other pertinent data. (An example of the recommended format for this announcement appears later in this section.)

II. METHOD OF ASSESSMENT

Before announcing a new lot of reference ammunition to the SAAMI Technical Office, the manufacturer should make sufficient tests to determine Tentative Values of pressure and velocity for the new lot.

1. The test barrels shall conform to the SAAMI specifications for internal dimensions, length and piezo gauge location. (Refer to the appropriate test barrel drawing for the cartridge under test.)
2. Counter-chronographs and photoelectric screens shall be used in velocity measurements. (See Section III.)
3. Ammunition shall be conditioned for a minimum of 24 hours at $70^{\circ} \pm 2^{\circ}\text{F}$ ($21.1^{\circ} \pm 1.1^{\circ}\text{C}$) with relative humidity of $60\% \pm 5\%$ before firing.

² Refer to page 54 for contact information for the SAAMI Technical Office.

NEW REFERENCE LOT REPORTING FORM AND INSTRUCTIONS

These instructions pertain to the form shown in Section II, which is used for a Reference Ammunition producer to announce new lots to the SAAMI Technical Office, as well as for the SAAMI Technical Office to announce the new lot to participating ranges.

SUBJECT: T-4020 Reference Ammunition – Rimfire
New Reference Lot

TO: *When used by a producer:*
SAAMI Technical Office³

When used by SAAMI Technical Office to notify test stations:
Current address of all stations and personnel.

(1) Name and address of source
for procurement as shown
in Section III

SIGNED: Authorized Person
Producer Company Name
Address (including zip
code)

DATE:

³ Refer to page 54 for contact information for the SAAMI Technical Office.

ANNOUNCEMENT OF NEW REFERENCE AMMUNITION LOT

SUBJECT: T-4020 Reference Ammunition – Rimfire
New Reference Lot

TO:

CARTRIDGE _____ Lot No. _____
Order Symbol _____

- TENTATIVE ASSESSMENT -

VELOCITY (ft/s)	PRESSURE (psi in units of 100)
_____	_____
AVERAGE: _____ σ : _____	AVERAGE: _____ σ : _____

Lot number this lot replaces _____

Please test the ammunition and report the results to the SAAMI Technical Office on the proper form (RF Section II) as soon as possible.

SIGNED:

DATE:

REFERENCE AMMUNITION: IDENTIFICATION PROTOCOL

SAAMI Reference Ammunition

This ammunition is to be used only for calibration
of test gages for velocity and pressure.

LOT NUMBERING SYSTEM (Typical numbers)

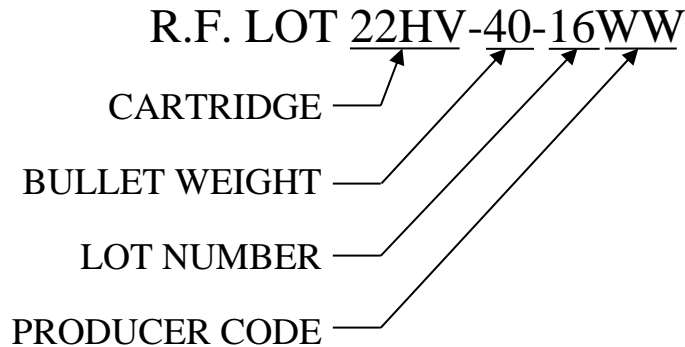

CARTRIDGE CODES

17M2	=	17 Mach 2
17HMR	=	17 Hornady Magnum Rimfire
17WSM	=	17 Winchester Super Magnum
22HVS	=	22 Short, High Velocity
22HV	=	22 Long Rifle, High Velocity
22WRF	=	22 Winchester Rimfire
22WMR	=	22 Winchester Magnum

PRODUCER CODES

<i>B</i>	=	<i>Blount (Alliant Ammunition & Accessories) OBSOLETE</i>
CS	=	CCI/Speer
F	=	Federal Cartridge Co.
H	=	Hornady Manufacturing
R	=	Remington Arms Company, LLC
WW	=	Winchester Division, Olin Corporation

NOTE

BLACK LETTERING

REFERENCE AMMUNITION: PERIODIC ASSESSMENT

I. PROCUREMENT

Reference ammunition is procured as noted on pages 75 and 76.

II. PERIODIC TESTS

A. STATIONS

1. All test conditions should conform as closely as possible to those prescribed in this Standard, and the following conditions should be met:
 - a) Tests should consist of ten (10) rounds for velocity and pressure fired during a single day.
 - b) Test barrels shall conform to SAAMI specifications for internal dimensions, length, and transducer location.
 - c) Counter-chronographs and photoelectric screens (or equivalents) shall be used in velocity measurements. (See Section III.)
 - d) Ammunition shall be conditioned for 72 hours at $70^{\circ} \pm 2^{\circ}\text{F}$ ($21.1^{\circ} \pm 1.1^{\circ}\text{C}$) with relative humidity of $60\% \pm 5\%$ before firing.
2. Each station should report results of its firing in the test on approved forms to the SAAMI Technical Office⁴. A sample of this report form is presented later in this subsection.

B. CLEARING HOUSE

1. The SAAMI Technical Office serves as the clearinghouse for all Reference Ammunition ballistics and related information. It shall be the responsibility of the SAAMI Technical Office to schedule testing and to assemble and distribute results of periodic tests. This should be done on the proper Reference Ammunition report form, as sample of which appears in this subsection.
2. The Reference Ammunition Report shall contain the average pressure, velocity, and related standard deviations as reported by each station for that lot. From this data, the SAAMI Technical Office will calculate and report the Raw Average, Corrected Average, and Inclusion Limits.
3. To obtain the Raw Averages, the SAAMI Technical Office shall include the 10-round averages for pressure and velocity of all reporting stations and the first and second previous assessment value. If the 10-round average from any station varies from the Raw Average by more than plus or minus 25 fps in velocity OR

⁴ Refer to page 54 for contact information for the SAAMI Technical Office.

plus or minus 1,700 psi in pressure, the pressure or velocity data from that (those) station(s) should be discarded. The mean pressure and velocity data should be recalculated omitting the discarded data. The new mean is the “Corrected Average”. If the mean pressure value of a station is outside of the limits as defined above, but the velocity is in, the pressure data should be dropped and the velocity data retained. The converse is true as well. Using the Corrected Averages, the Inclusion Limits are determined as follows:

VELOCITY: MEAN = Same as Corrected Average
 HIGH = MEAN + 25 fps
 LOW = MEAN – 25 fps

PRESSURE: MEAN = Same as Corrected Average
 HIGH = MEAN + 1,700 psi
 LOW = MEAN – 1,700 psi

T-4020 STATION REPORT
REFERENCE AMMUNITION – PERIODIC ASSESSMENT
RIMFIRE

STATION _____

SAAMI REFERENCE LOT _____

DATE _____

PREVIOUS ASSESSMENT

Velocity _____

Pressure _____

Barrel No. _____

Rounds to-date _____

Type of Gage _____

No. _____

	VELOCITY	PRESSURE
1.		
2.		
3.		
4.		
5.		
6.		
7.		
8.		
9.		
10.		
AVERAGE		
OFFSET		
FINAL AVERAGE.		
$\sigma_{(n-1)}$		

TECHNICAL SERVICES REPORT – REFERENCE AMMUNITION

PERIODIC ASSESSMENT – RIMFIRE

MARCH – 2002

LOT NO.: 22HV-40-16WW **GAGE: PIEZO**

	VELOCITY	□	PRESSURE	□	OFFSET
Alliant	-	-	-	-	-
Blount	1232	6.0	243	10.1	69
Federal	1218	15.0	< 201	16.0	62
Fiocchi	-	-	-	-	-
Hornady	-	-	-	-	-
St. Marks Powders	1223	14.0	236	10.7	66
Remington – E-Town	1229	21.0	238	10.5	71
Remington - Ilion	-	-	-	-	-
Remington – Lonoke	1253	8.1	239	7.9	67
Winchester	1232	8.0	231	12.0	49
1 st Previous Average	1232		233		
2 nd Previous Average	1235		240		
Raw Average	1232		233		
Corrected Average	1232		237		
INCLUSION LIMITS @ 99.95%	+/- 25		+/- 17		
Upper Limit	1257		254		
Lower Limit	1207		220		
ASSESSMENT	1232		237		

> - DISCARDED DATA-ABOVE RAW INCLUSION LIMIT
< - DISCARDED DATA-BELOW RAW INCLUSION LIMIT

* - FIRST TIME ASSESSED
**- LAST TIME ASSESSED

EQUIPMENT: VELOCITY & CONFORMAL PIEZOELECTRIC PRESSURE TESTING

NOTE: Refer to page 55, *Supplier Contact Information*, for detailed information on contacting the manufacturers of listed products and the SAAMI Technical Office.

1. Electronic Counter Chronograph – 100 kilohertz, minimum
Oehler Research, Electronic Counters, Inc., or equivalent.
2. Table of velocity vs. time of flight or electronic calculator.

NOTE: Items (1) and (2) may be replaced by a direct-reading velocity chronograph or integrated ballistic instrumentation system with equivalent accuracy and precision.

3. Photoelectric screens
Oehler Research, Electronic Counters, Inc., or equivalent.
4. Universal Receiver
 - a) Ulysses Machine Company
 - b) H-S Precision, Inc.
 - c) Other equivalent.
5. Test Barrel (Drawings of test barrels are presented in Section III).
 - a) H-S Precision, Inc.
 - b) Wiseman
 - c) Wilson Arms Company
 - d) Hart Rifle Barrels, Inc.
 - e) Krieger Barrels, Inc.
 - f) Or equivalent.

6. Digital voltmeter
Fluke model 8440 or equivalent
7. Charge amplifier with 20KHz low pass filter
PCB Piezotronics, Inc. model 443B02 or equivalent
8. Peak meter
PCB Piezotronics, Inc. model 444A152 or equivalent

NOTE: Items (7) and (9) or (7), (8), and (9) may be replaced by an integrated ballistic instrumentation system of equivalent accuracy and precision.

9. Piezoelectric transducer
PCB Piezotronics, Inc. model 117Bxx or equivalent
10. Low noise cable
PCB Piezotronics, Inc. model 003A05 or equivalent
11. Transducer calibrator
PCB Group; The Modal Shop, Inc.; Model K9905D or equivalent

12. Calibration adapter
PCB Piezotronics, Inc. model 090B series or equivalent
13. Reference ammunition
Refer to Section III, page 75 for supply sources.

SUPPLIER CONTACT INFORMATION

Contact the SAAMI Technical Office using the information below, or visit www.saami.org for a current list of supplier contact information.

SAAMI Technical Office

11 Mile Hill Road
Newtown, CT 06470
Phone: 203-426-4358
E-mail:
Website: www.saami.org

**EQUIPMENT:
 SCHEMATIC LAYOUT OF VELOCITY SCREENS**

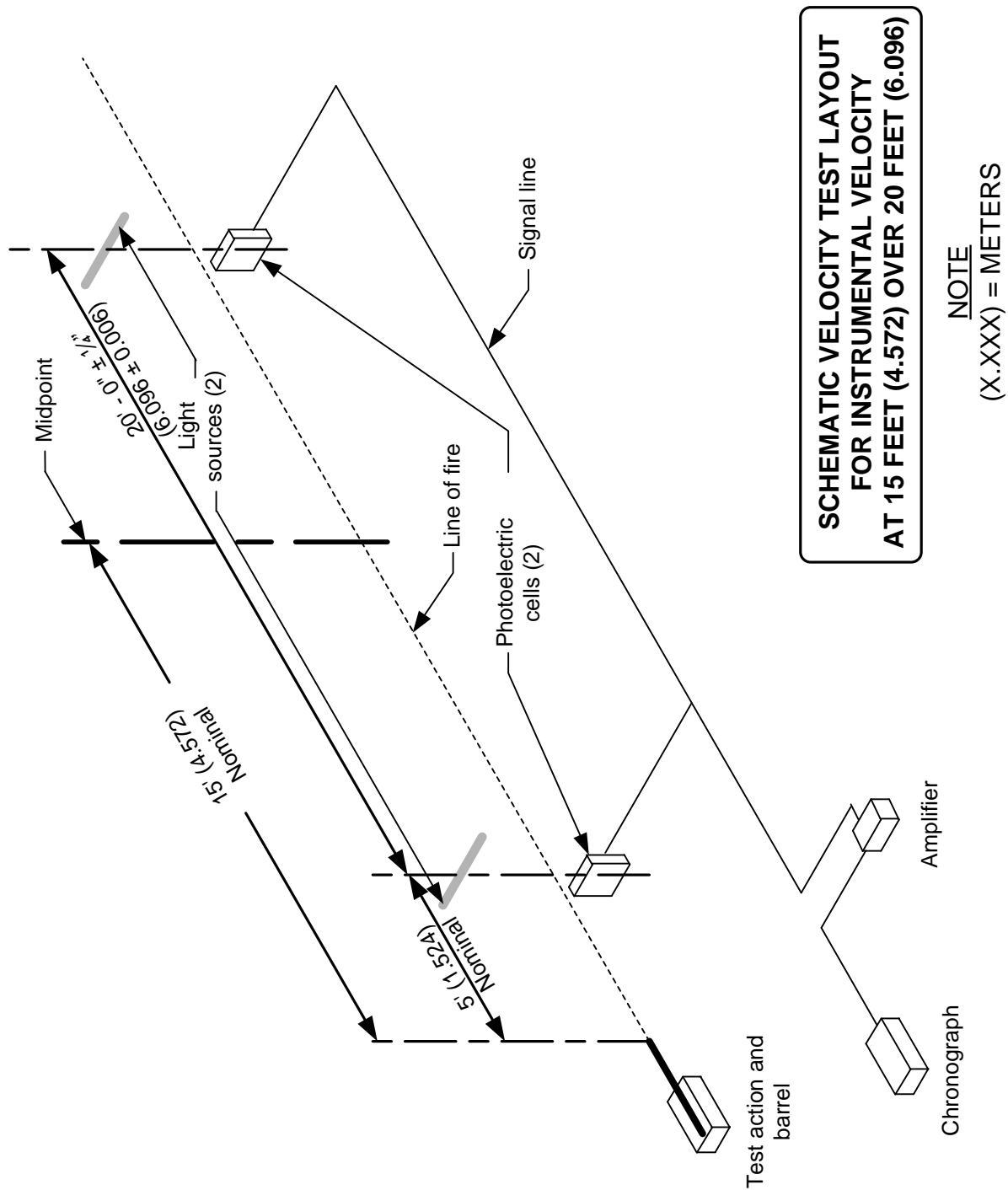

**EQUIPMENT:
UNIVERSAL RECEIVER COLLAR & TEST BARREL**

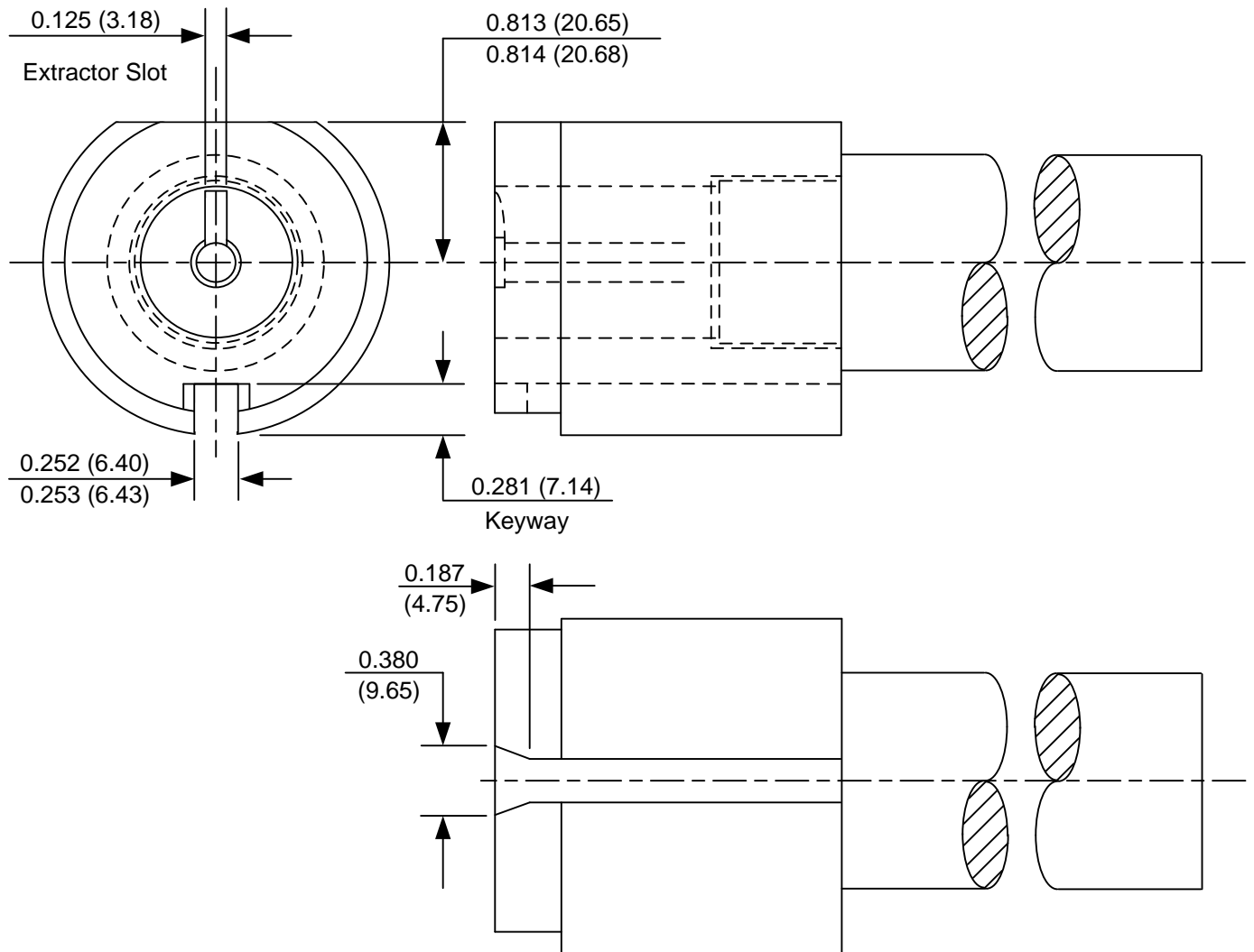

FOR DETAIL INFORMATION SEE FOLLOWING SHEET

NOTE: (XX.XX) = Millimeters

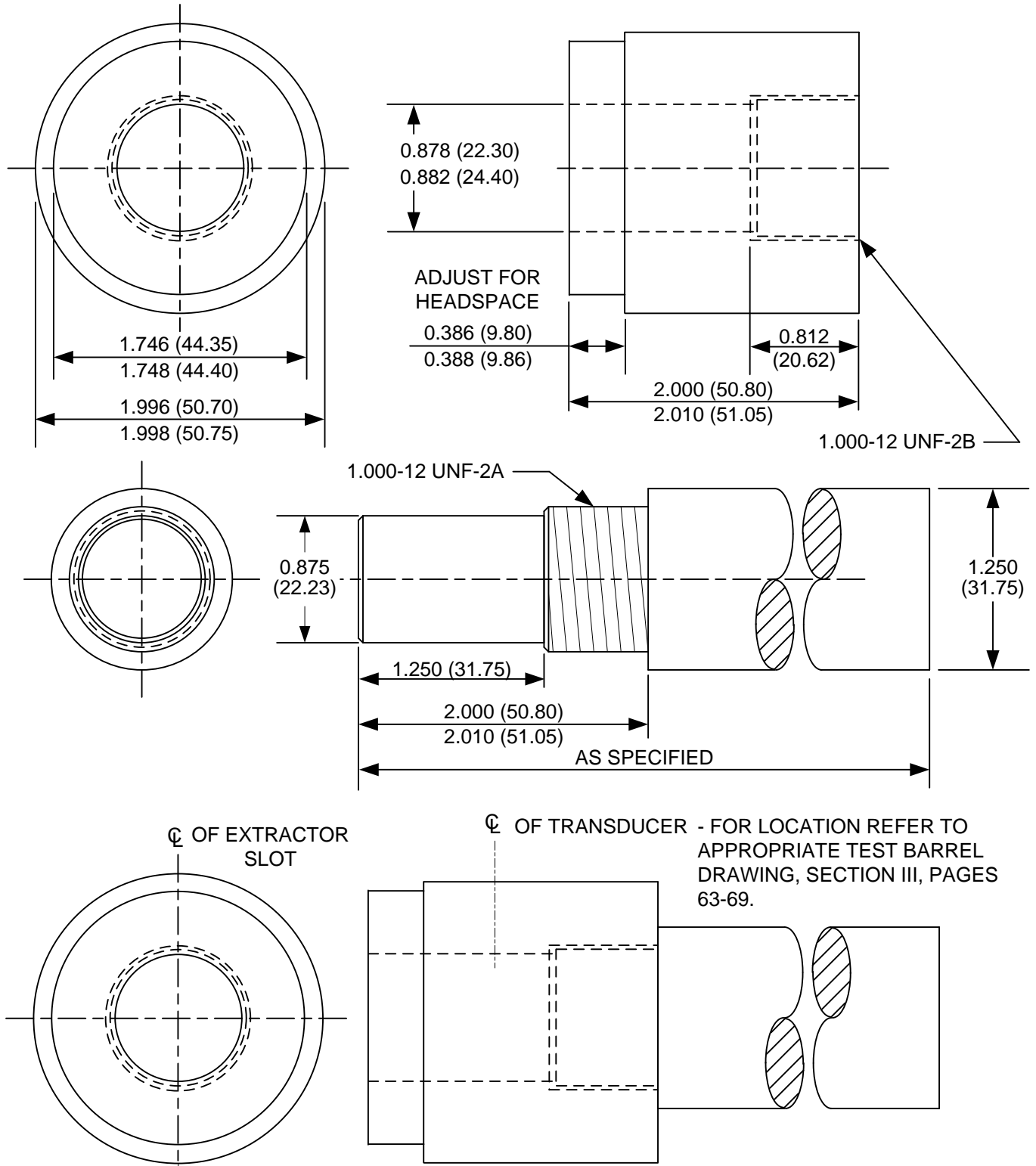

DRAW BARREL AND COLLAR TIGHT.
TRANSDUCER HOLE AND HEAD CUTS MADE
AFTER ASSEMBLY - SEE PAGE 58. ONE-
PIECE BARRELS ARE ACCEPTABLE.
NOTE: (XX.XX) = MILLIMETERS

MATERIAL: RESULTURIZED 4140 STEEL HEAT
TREAT PRIOR TO MACHINING TO BRINELL
HARDNESS 277 TO 321 (R_c 29 TO 35)
ACCEPTABLE ALTERNATE: 416 STAINLESS STEEL

**UNIVERSAL RECEIVER TEST BARREL:
INSTALLATION OF PRESSURE TRANSDUCERS**

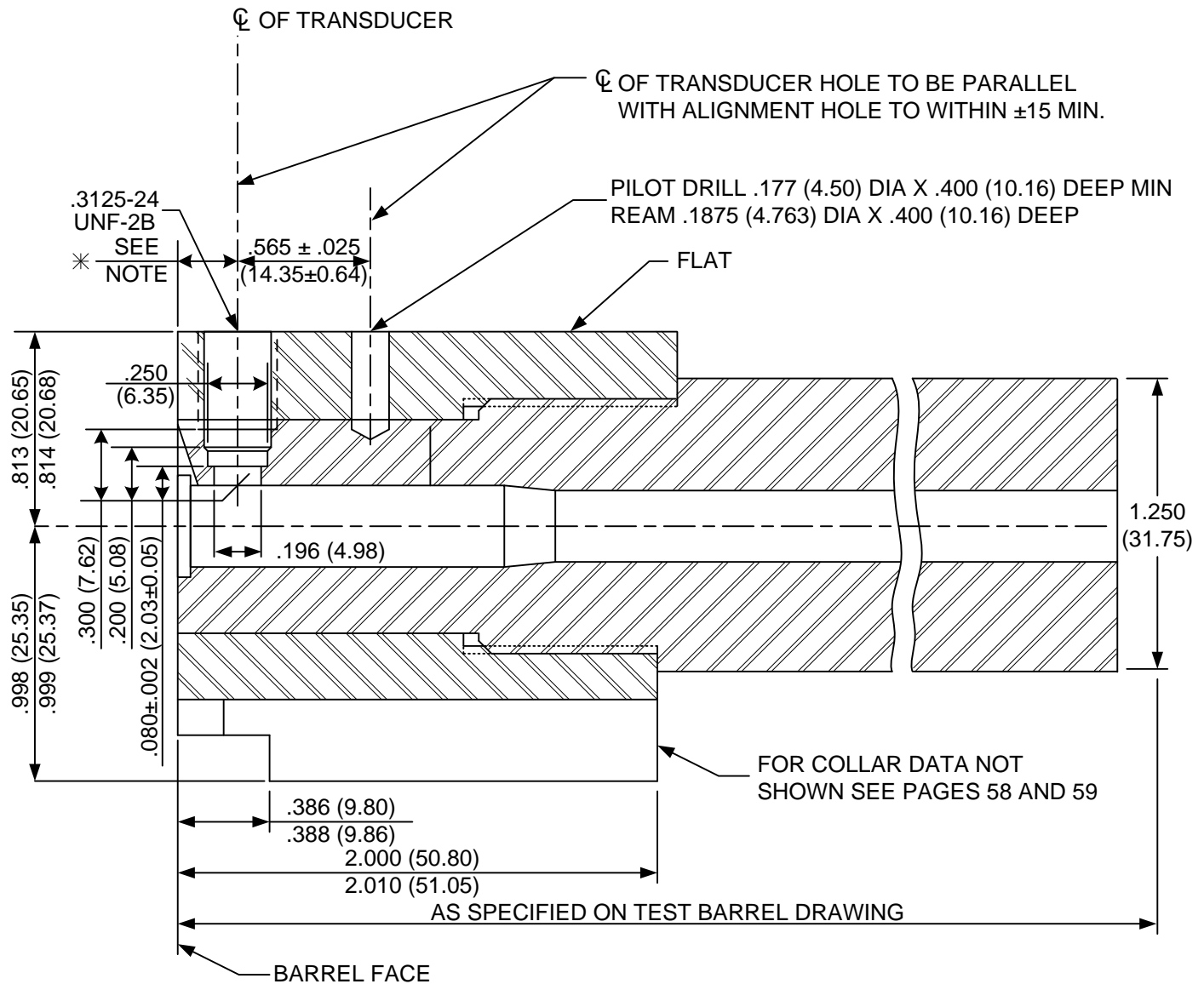

NOTE

* REFER TO APPROPRIATE TEST BARREL DRAWING FOR TRANSDUCER LOCATION.

(XX.XX) = MILLIMETERS

**STANDARD V&P TEST BARRELS - GENERAL:
PROCEDURES FOR DIMENSIONING CHAMBERS**

Chamber and bore dimensions of velocity and pressure test barrels shall conform to the dimensions of the chamber and bore at Maximum Material Condition (MMC) for each cartridge as originally introduced. Fabrication tolerances, however, are much reduced.

It is recognized that changes may be made to cartridge or chamber dimensions in order to improve the velocity-pressure relationship, accuracy or functioning in firearms as production experience indicates. However, none of these changes should be of such nature that they would cause a significant increase in pressure level of a given lot of ammunition.

No changes shall be made to velocity and pressure barrel dimensions which would result in a reduction of the recorded pressure level of any given lot of ammunition. This would result in the possibility of future lots of ammunition being loaded with increased powder charges, which would cause increased pressure in existing firearms.

Production barrels may be adapted for velocity and pressure testing provided that they conform to all dimensions shown on the appropriate test barrel drawing.

All standard rimfire rifle test barrels shall be 24 inches long; exterior ballistic data for all rimfire rifle cartridges shall be based on this length.

STANDARD V&P TEST BARRELS - GENERAL: PROCEDURES FOR MEASURING BARREL LENGTH

Rimfire solid test barrels are measured by inserting a rod down the bore from the muzzle until it touches the breech face with the action closed and the firing pin retracted.

A stop collar or other means is utilized to mark the point on the rod adjacent to the most forward part of the barrel or the bottom of the counterbore in barrels having a counterbore recess at the muzzle.

The rod is removed and the distance from the mark to the end of the rod is measured. This measurement is recorded as the barrel length.

17 Mach 2 V&P Test Barrel

Issued: 06/23/2004

Revised: 07/27/2015

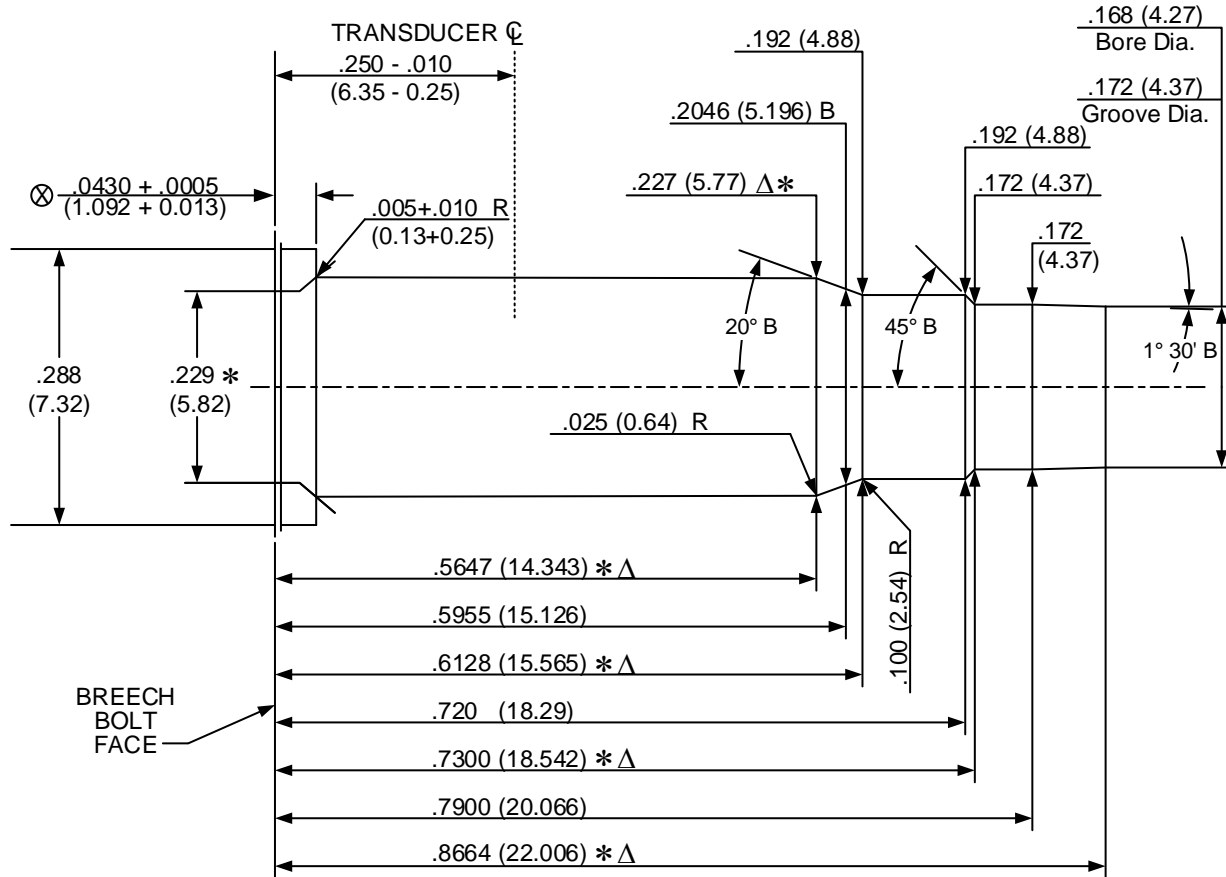

DO NOT SCALE FROM DRAWING

NUMBER OF GROOVES: 6
 WIDTH OF GROOVES: .062 + .002 (1.57 + 0.05)
 TWIST RATE: 9.00 (228.6) R.H.
 BARREL LENGTH: 24.000±.010 (609.60±0.25)

LAND AND GROOVE DIMENSIONS TO BE WITHIN TOLERANCES
THROUGHOUT LENGTH OF BARREL.

UNLESS OTHERWISE NOTED,
 ALL DIAMETERS +.0005 (0.013)
 LENGTH TOLERANCE + .005 (0.13)

NOTE:

B = BASIC Δ = REFERENCE DIMENSION ⊗ = HEADSPACE DIMENSION
 * DIMENSIONS ARE TO INTERSECTIONS OF LINES (XX.XX) = MILLIMETERS
 ALL CALCULATIONS APPLY AT MAXIMUM MATERIAL CONDITION (MMC)

17 Hornady Magnum Rimfire V&P Test Barrel

Issued: 06/26/2002

Revised: 07/27/2015

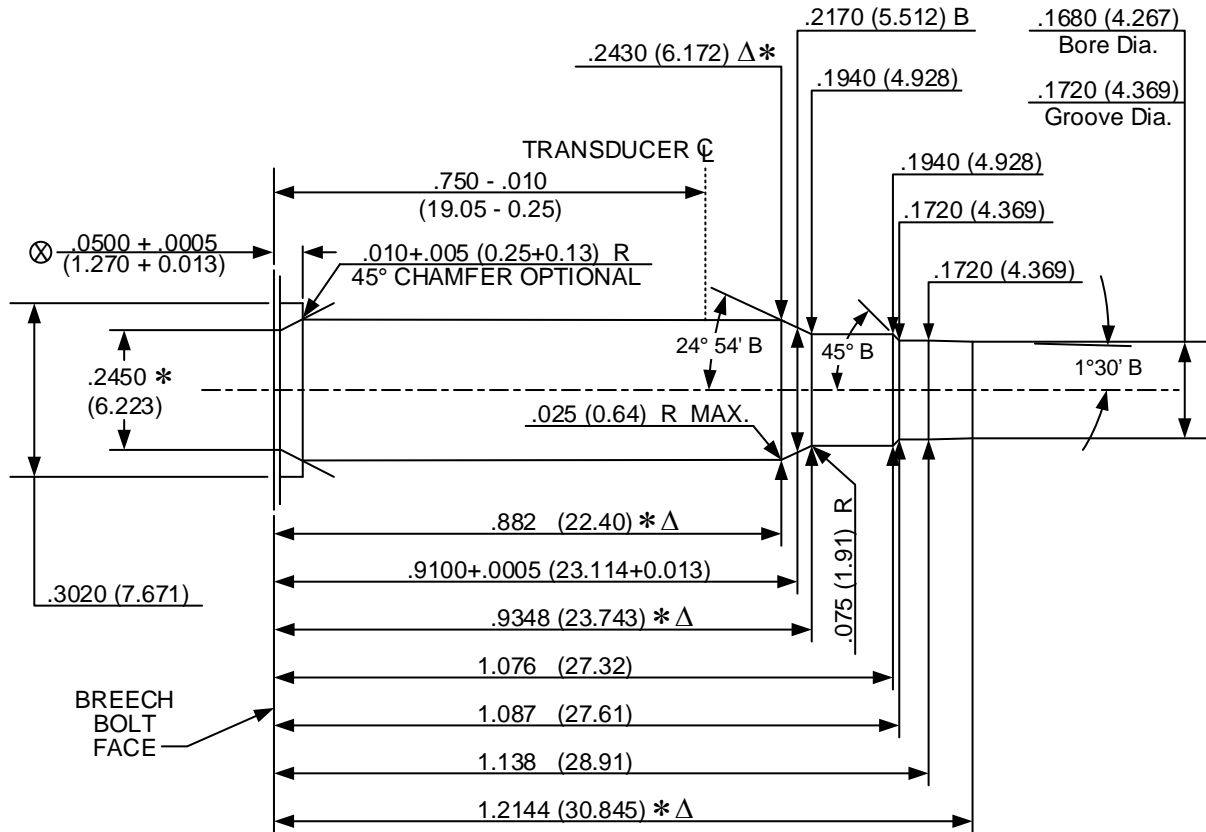

DO NOT SCALE FROM DRAWING

NUMBER OF GROOVES: 6
WIDTH OF GROOVES: .062 + .002 (1.57 + 0.05)
TWIST RATE: 9.00 (228.6) R.H.
BARREL LENGTH: 24.000±.010 (609.60±0.25)

LAND AND GROOVE DIMENSIONS TO BE WITHIN TOLERANCES
THROUGHOUT LENGTH OF BARREL.

UNLESS OTHERWISE NOTED,
ALL DIAMETERS +.0005 (0.013)
LENGTH TOLERANCE + .005 (0.13)

NOTE:

B = BASIC Δ = REFERENCE DIMENSION ⊗ = HEADSPACE DIMENSION
* DIMENSIONS ARE TO INTERSECTIONS OF LINES (XX.XX) = MILLIMETERS
ALL CALCULATIONS APPLY AT MAXIMUM MATERIAL CONDITION (MMC)

17 Winchester Super Magnum V&P Test Barrel

Issued: 01/14/2013

Revised: 07/27/2015

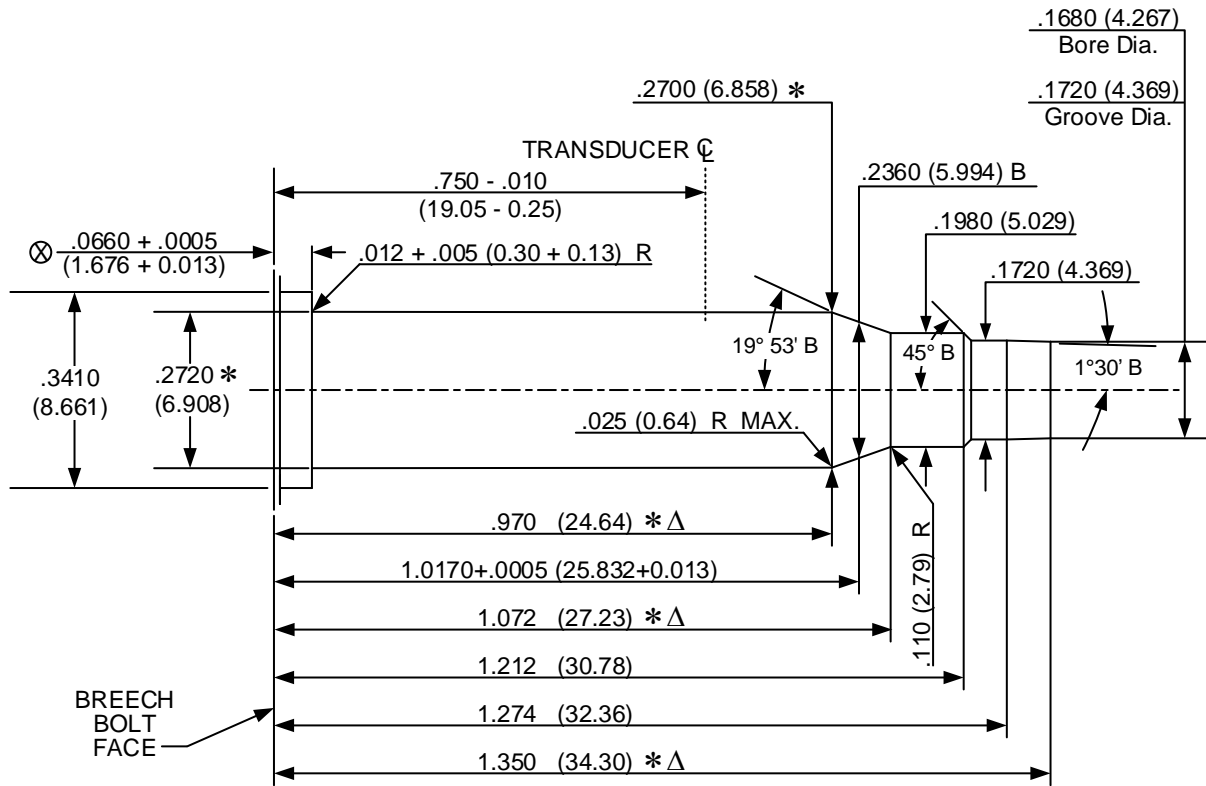

DO NOT SCALE FROM DRAWING

NUMBER OF GROOVES: 6
 WIDTH OF GROOVES: .062 + .002 (1.57 + 0.05)
 TWIST RATE: 9.00 (228.6) R.H.
 BARREL LENGTH: 24.000±.010 (609.60±0.25)

LAND AND GROOVE DIMENSIONS TO BE WITHIN TOLERANCES
 THROUGHOUT LENGTH OF BARREL.

UNLESS OTHERWISE NOTED,
 ALL DIAMETERS +.0005 (0.013)
 LENGTH TOLERANCE + .005 (0.13)

NOTE:

B = BASIC Δ = REFERENCE DIMENSION ⊗ = HEADSPACE DIMENSION
 * DIMENSIONS ARE TO INTERSECTIONS OF LINES (XX.XX) = MILLIMETERS
 ALL CALCULATIONS APPLY AT MAXIMUM MATERIAL CONDITION (MMC)

22 Short V&P Test Barrel

Issued: 02/01/1974

Revised: 07/27/2015

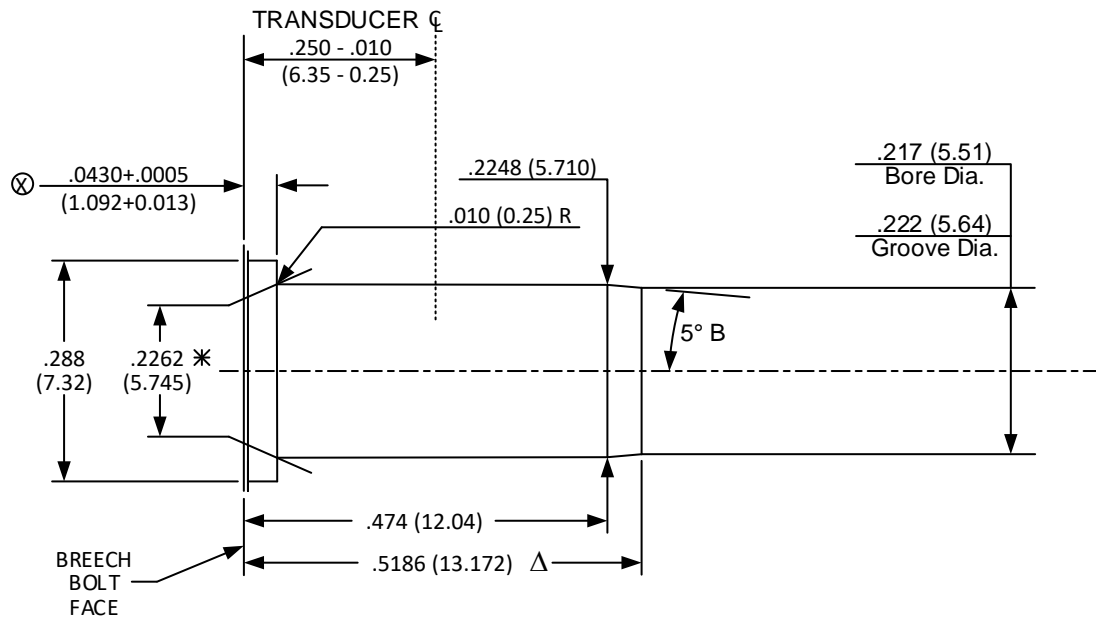

DO NOT SCALE FROM DRAWING

- NUMBER OF GROOVES: 6
- WIDTH OF GROOVES: .085+0.002 (2.16+0.05)
- TWIST RATE: 16 (406.4) RH
- BARREL LENGTH: 24.000±.010 (609.60±0.25)

LAND AND GROOVE DIMENSIONS TO BE WITHIN TOLERANCES THROUGHOUT LENGTH OF BARREL.

UNLESS OTHERWISE NOTED,
ALL DIAMETERS +.0005 (0.013)
LENGTH TOLERANCE + .005 (0.13)

NOTE:

B = BASIC Δ = REFERENCE DIMENSION ⊗ = HEADSPACE DIMENSION
* DIMENSIONS ARE TO INTERSECTIONS OF LINES (XX.XX) = MILLIMETERS
ALL CALCULATIONS APPLY AT MAXIMUM MATERIAL CONDITION (MMC)

22 Long / 22 Long Rifle V&P Test Barrel

Issued: 02/01/1974

Revised: 11/28/2002

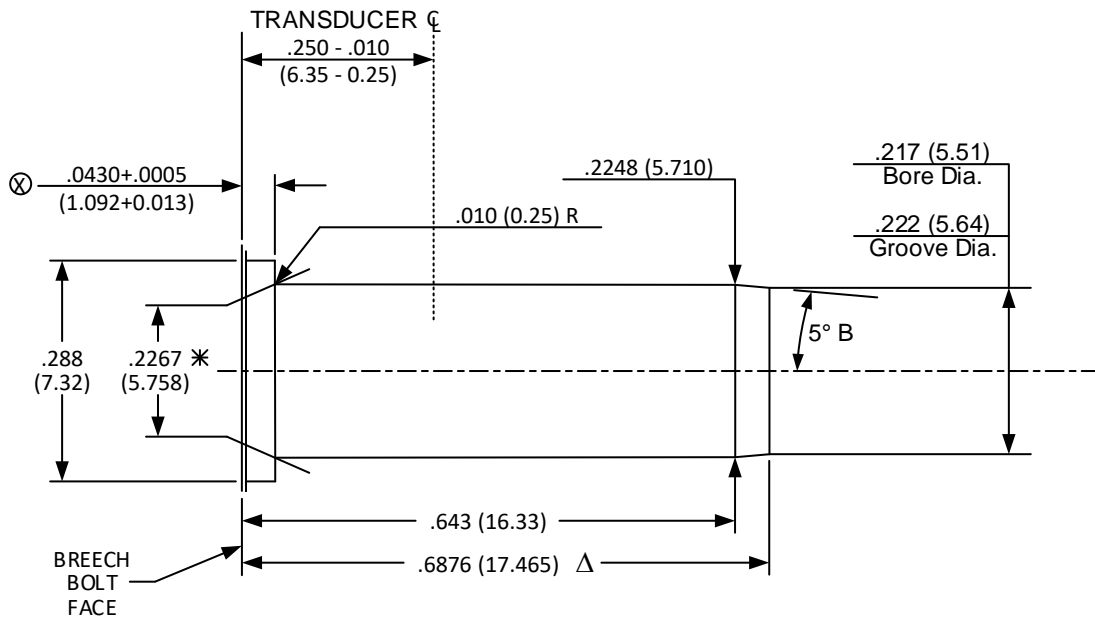

DO NOT SCALE FROM DRAWING

NUMBER OF GROOVES: 6
 WIDTH OF GROOVES: .085 + .002 (2.16 + 0.05)
 TWIST RATE: 16 (406.4) RH
 BARREL LENGTH: 24.000 ± .010 (609.60 ± 0.25)

LAND AND GROOVE DIMENSIONS TO BE WITHIN TOLERANCES THROUGHOUT LENGTH OF BARREL.

UNLESS OTHERWISE NOTED,
 ALL DIAMETERS +.0005 (0.013)
 LENGTH TOLERANCE + .005 (0.13)

NOTE:

B = BASIC Δ = REFERENCE DIMENSION \textcircled{X} = HEADSPACE DIMENSION
 * DIMENSIONS ARE TO INTERSECTIONS OF LINES (XX.XX) = MILLIMETERS
 ALL CALCULATIONS APPLY AT MAXIMUM MATERIAL CONDITION (MMC)

22 Long Rifle Shot V&P Test Barrel

Issued: 02/01/1974

Revised: 11/28/2002

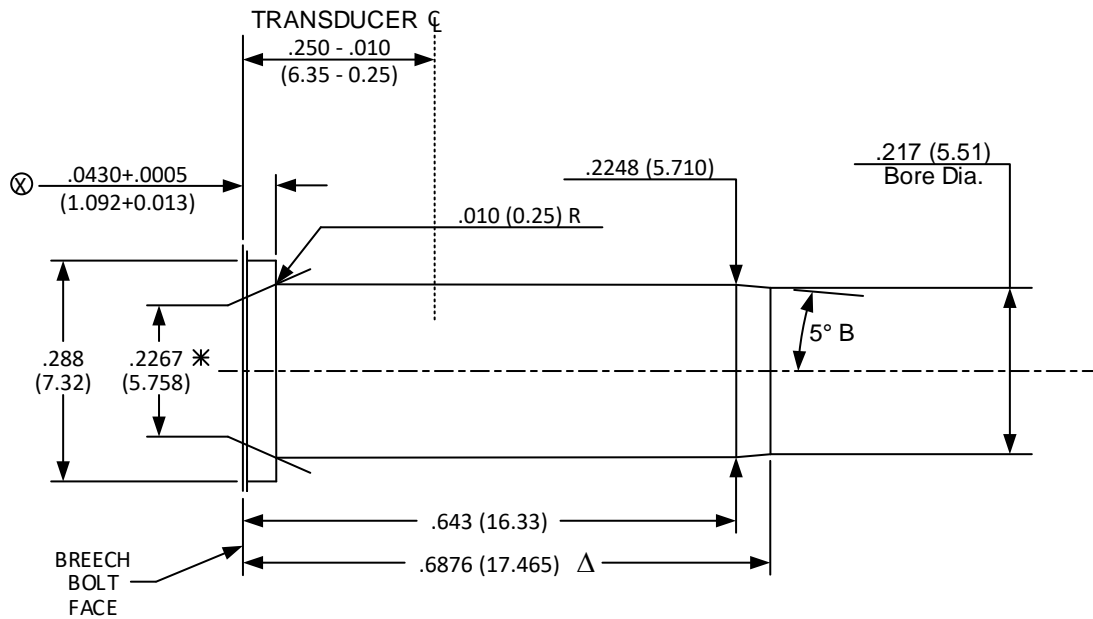

DO NOT SCALE FROM DRAWING

NUMBER OF GROOVES: 0
WIDTH OF GROOVES: 0 - SMOOTH BORE
TWIST RATE: N/A
BARREL LENGTH: 24.000±.010 (609.60±0.25)

UNLESS OTHERWISE NOTED,
ALL DIAMETERS +.0005 (0.013)
LENGTH TOLERANCE + .005 (0.13)

NOTE:

B = BASIC Δ = REFERENCE DIMENSION ⊗ = HEADSPACE DIMENSION
* DIMENSIONS ARE TO INTERSECTIONS OF LINES (XX.XX) = MILLIMETERS
ALL CALCULATIONS APPLY AT MAXIMUM MATERIAL CONDITION (MMC)

22 Winchester Rimfire V&P Test Barrel

Issued: 01/06/2007

Revised: 07/27/2015

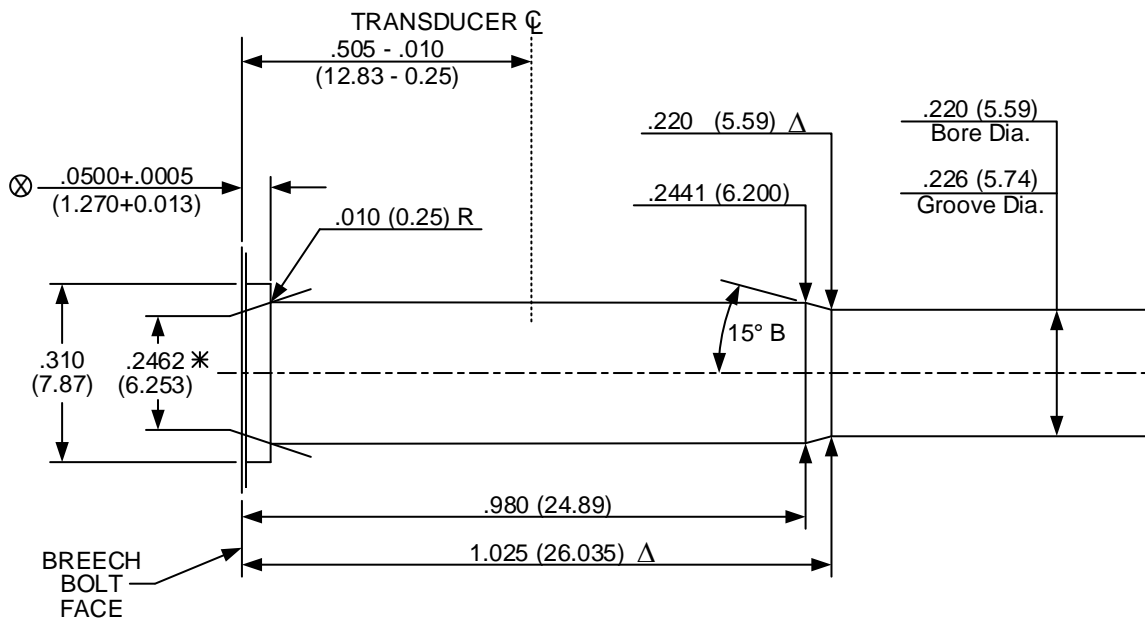

DO NOT SCALE FROM DRAWING

NUMBER OF GROOVES: 6
 WIDTH OF GROOVES: .075+0.002 (1.91+0.05)
 TWIST RATE: 14 (406.4) RH
 BARREL LENGTH: 24.000±0.010 (609.60±0.25)

LAND AND GROOVE DIMENSIONS TO BE WITHIN TOLERANCES
THROUGHOUT LENGTH OF BARREL.

UNLESS OTHERWISE NOTED,
 ALL DIAMETERS +.0005 (0.013)
 LENGTH TOLERANCE + .005 (0.13)

NOTE:

B = BASIC Δ = REFERENCE DIMENSION \textcircled{X} = HEADSPACE DIMENSION
 * DIMENSIONS ARE TO INTERSECTIONS OF LINES (XX.XX) = MILLIMETERS
 ALL CALCULATIONS APPLY AT MAXIMUM MATERIAL CONDITION (MMC)

22 Winchester Magnum V&P Test Barrel

Issued: 02/01/1974

Revised: 07/27/2015

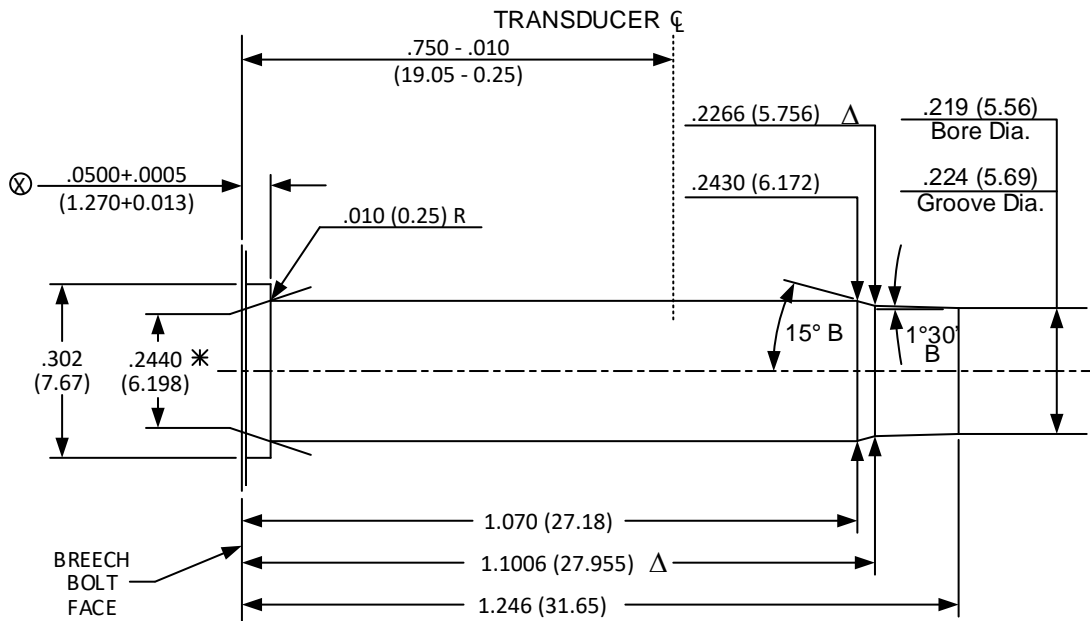

DO NOT SCALE FROM DRAWING

NUMBER OF GROOVES: 6
 WIDTH OF GROOVES: $.074 + .002$ (1.88 + 0.05)
 TWIST RATE: 16 (406.4) RH
 BARREL LENGTH: $24.000 \pm .010$ (609.60 \pm 0.25)

LAND AND GROOVE DIMENSIONS TO BE WITHIN TOLERANCES THROUGHOUT LENGTH OF BARREL.

UNLESS OTHERWISE NOTED,
 ALL DIAMETERS $+ .0005$ (0.013)
 LENGTH TOLERANCE $+ .005$ (0.13)

NOTE:

B = BASIC Δ = REFERENCE DIMENSION \textcircled{X} = HEADSPACE DIMENSION
 * DIMENSIONS ARE TO INTERSECTIONS OF LINES (XX.XX) = MILLIMETERS
 ALL CALCULATIONS APPLY AT MAXIMUM MATERIAL CONDITION (MMC)

**HEADSPACES GAUGES:
17 MACH 2**

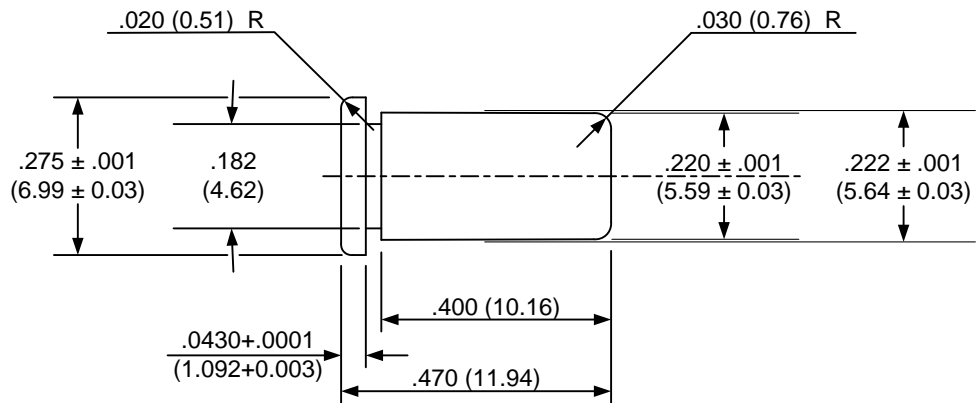

MINIMUM HEADSPACE GAUGE

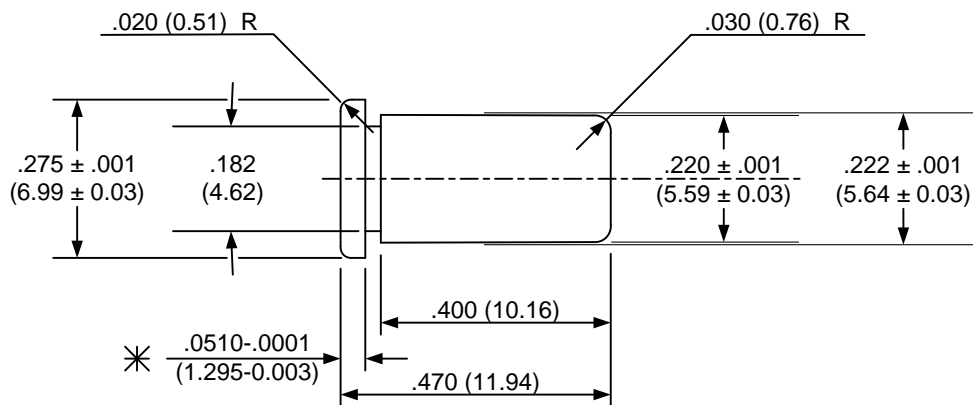

MAXIMUM HEADSPACE GAUGE

NOTE:
(XX.XX) = MILLIMETERS
HARDEN AND GRIND
* REPRESENTS MAXIMUM ADVISABLE CONDITION AFTER USE
UNLESS OTHERWISE NOTED ALL TOLERANCES ± .005 (0.13)

**HEADSPACES GAUGES:
17 HORNADY MAGNUM RIMFIRE**

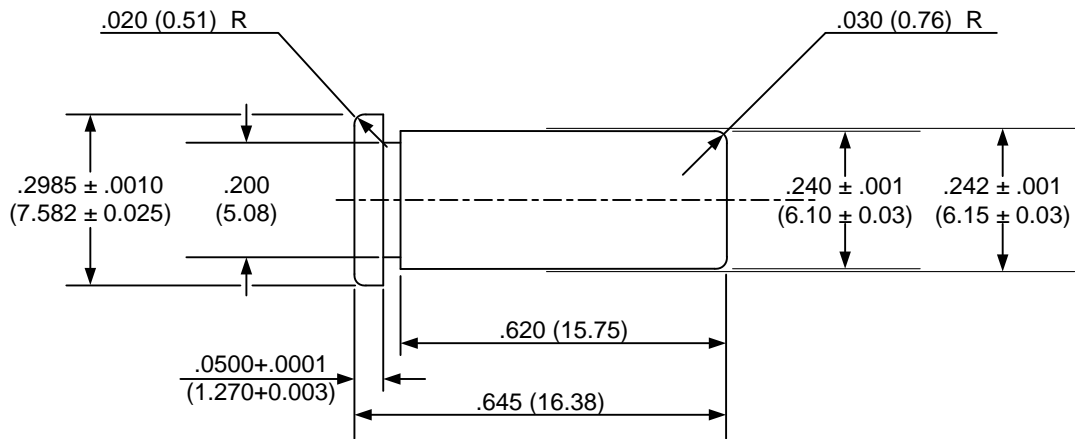

MINIMUM HEADSPACE GAUGE

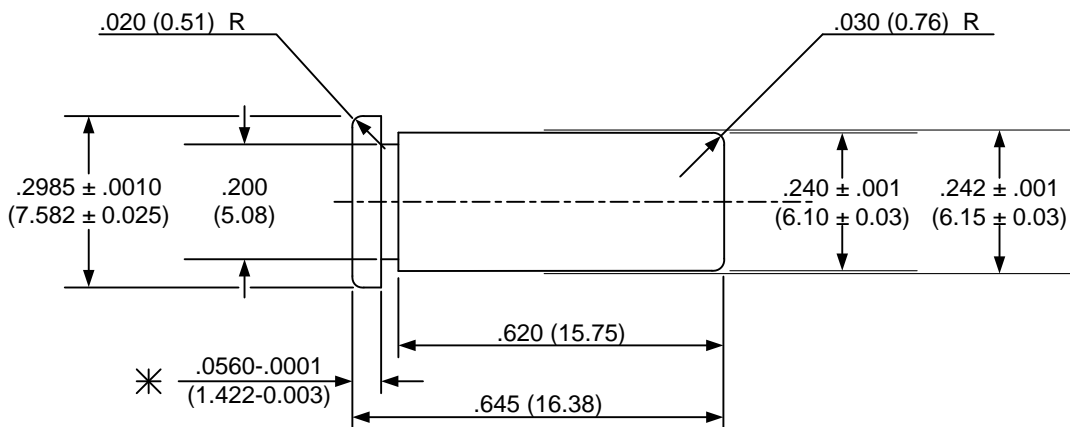

MAXIMUM HEADSPACE GAUGE

NOTE:

(XX.XX) = MILLIMETERS

HARDEN AND GRIND

* REPRESENTS MAXIMUM ADVISABLE CONDITION AFTER USE
UNLESS OTHERWISE NOTED ALL TOLERANCES ± .005 (0.13)

**HEADSPACES GAUGES:
17 WINCHESTER SUPER MAGNUM**

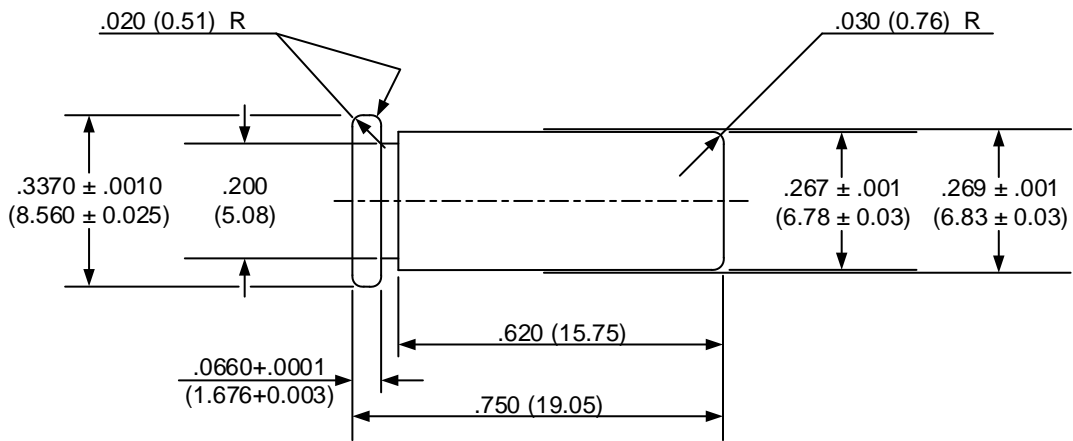

MINIMUM HEADSPACE GAUGE

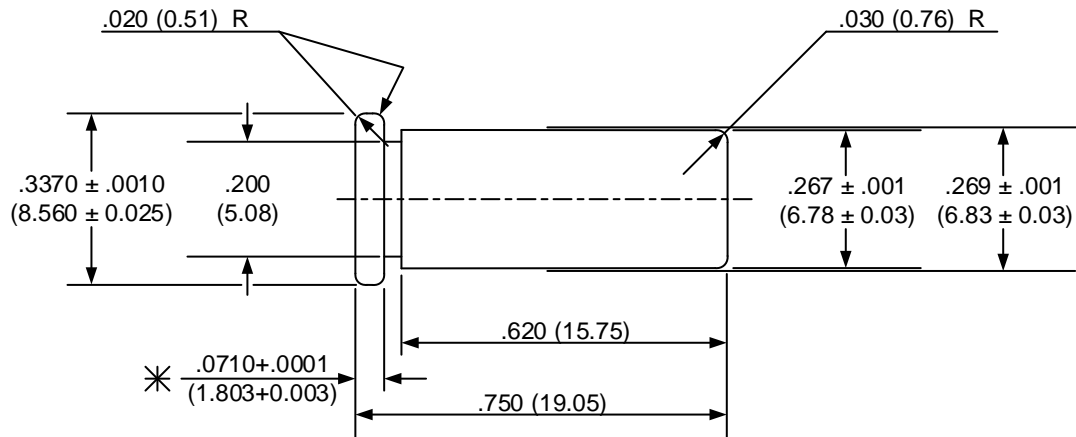

MAXIMUM HEADSPACE GAUGE

NOTE:

(XX.XX) = MILLIMETERS

HARDEN AND GRIND

* REPRESENTS MAXIMUM ADVISABLE CONDITION AFTER USE

UNLESS OTHERWISE NOTED ALL TOLERANCES ± .005 (0.13)

**HEADSPACES GAUGES:
22 SHORT, LONG, LONG RIFLE, and LONG RIFLE SHOT**

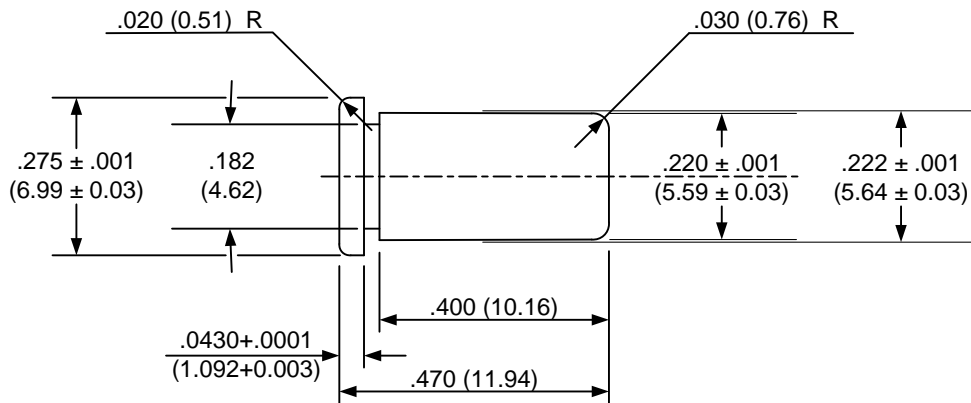

MINIMUM HEADSPACE GAUGE

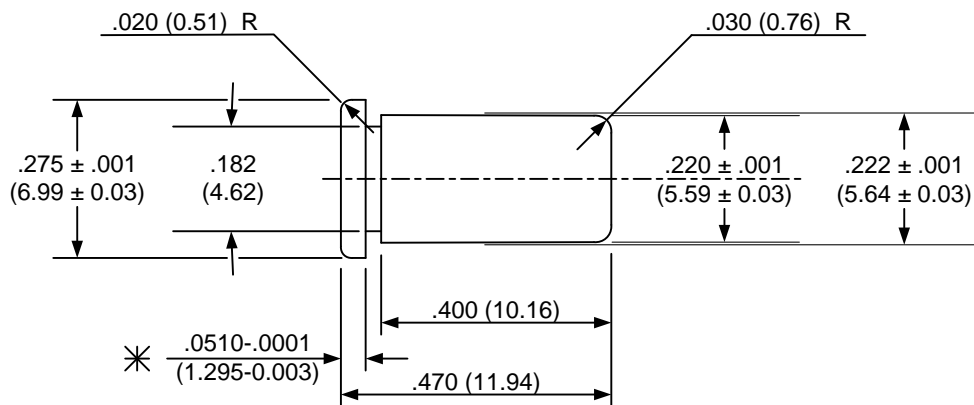

MAXIMUM HEADSPACE GAUGE

NOTE:
(XX.XX) = MILLIMETERS
HARDEN AND GRIND
* REPRESENTS MAXIMUM ADVISABLE CONDITION AFTER USE
UNLESS OTHERWISE NOTED ALL TOLERANCES ± .005 (0.13)

**HEADSPACES GAUGES:
22 WINCHESTER RIMFIRE and 22 WINCHESTER MAGNUM**

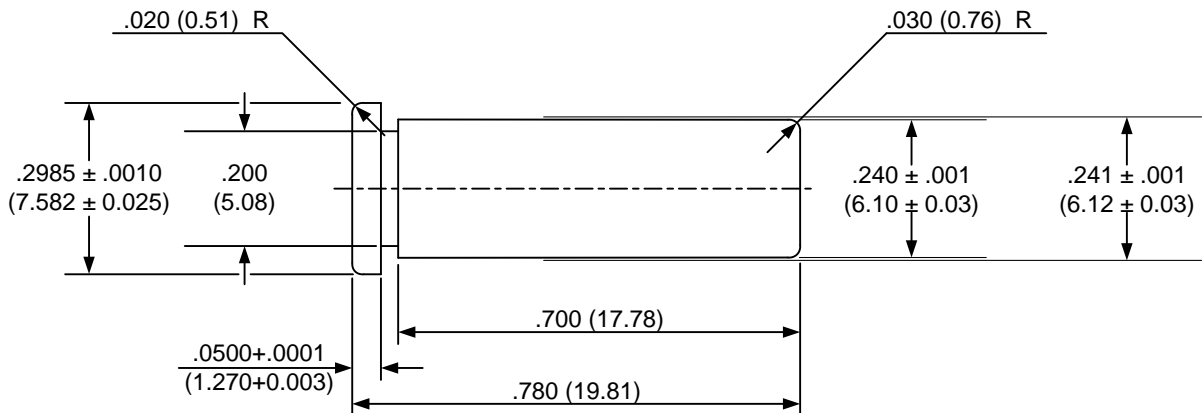

MINIMUM HEADSPACE GAUGE

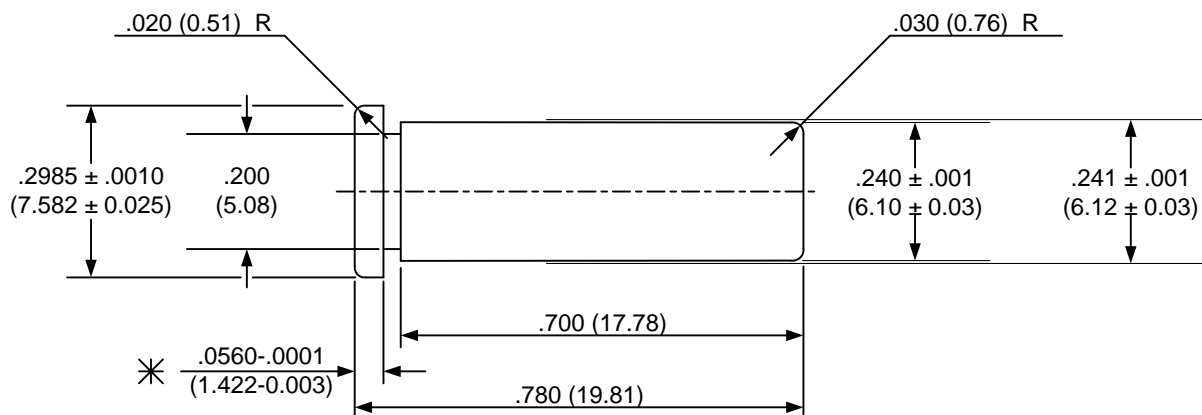

MAXIMUM HEADSPACE GAUGE

NOTE:

(XX.XX) = MILLIMETERS
HARDEN AND GRIND

* REPRESENTS MAXIMUM ADVISABLE CONDITION AFTER USE
UNLESS OTHERWISE NOTED ALL TOLERANCES ± .005 (0.13)

**EQUIPMENT:
REFERENCE AMMUNITION SUPPLY**

NOTE: Refer to page 55, *Supplier Contact Information*, for detailed information on contacting the manufacturers of listed products and the SAAMI Technical Office.

Rimfire reference ammunition are for the verification of ranges, barrels, and other equipment.

Information on procurement and assessment may be obtained from the SAAMI Technical Office. SAAMI policy does not allow the release of assessment values by the manufacturer of reference ammunition. All assessments are to be supplied by the SAAMI Technical Office.

EQUIPMENT:
REFERENCE AMMUNITION ORDER PROCEDURE

Each order should contain the following information, in the following order:

1. Number of rounds desired. (See NOTE, below.)
2. Appropriate order symbol.
3. Designation “SAAMI Reference Ammunition”.
4. Cartridge name.
5. SAAMI lot number. (Current lot numbers are given on latest assessment value sheets issued by the SAAMI Technical Office.)

EXAMPLE:

500 rounds, Order symbol (*per current listing*)
SAAMI Reference Ammunition
22 Long Rifle
SAAMI Lot 22HV-40-17WW

NOTE: Recommended maximum order = 500 rounds. If an individual user has requirements for larger quantities, refer to page 44.

Manufacturers of SAAMI reference ammunition may limit the order quantities honored to the recommended maximum in order to prevent premature consumption of a lot.

It is up to the discretion of the manufacturer to produce lots of sufficient size to reasonably provide a five-year supply.

DEFINITION AND PURPOSE

SAAMI Definitive Proof cartridges are cartridges commercially loaded by SAAMI member companies which develop pressure substantially exceeding those developed by normal service loads. The pressure levels are designed to assure gun safety when using ammunition loaded to service pressures in accordance with accepted American practices.

Proof cartridges are designed to stress firearms components which contain the cartridge in order to assure safety in the recommended use of the firearm during its service life.

It is important from the safety standpoint that Definitive Proof cartridges be used **only** for the proof of firearms. Adequate precaution must be taken to protect personnel performing firearms proof testing.

The supply of Definitive Proof cartridges will be the responsibility of the company that first introduced that particular caliber to the Institute. Definitive Proof Cartridges should be loaded with the heaviest bullet used at the time of introduction and the slowest powder which will meet the pressure values indicated for that particular cartridge to maintain effective pressure-distance relationship. Once established, the bullet weight for the proof load does not change unless the bullet becomes obsolete. All changes in Definitive Proof cartridges bullet weight must be approved by the SAAMI Joint Technical Committee.

PRESSURE DATA INTERPRETATION

The following specifications define the proof loads based on tests fired in standard test barrels with the ammunition at a temperature of 60°-80°F (15.6°-26.7°C). Tests shall be in accordance with the procedures and equipment shown in Sections II and III of this Standard.

Pressure values are given on the following pages in terms of minimum and maximum averages and extreme variations for 10-round tests in standard test barrels.

For Rimfire, the Standard Deviations for Definitive Proof Cartridges are the same as the Standard Deviations for service loads.

The minimum and maximum average Definitive Proof Pressures are computed as follows:

- The Minimum Average Definitive Proof Pressure is calculated by multiplying the Maximum Probable Lot Mean (MPLM) service pressure by a factor of 1.25 (i.e., 125%) and rounding **UP** to the nearest multiple of 500 psi.
- The Maximum Average Definitive Proof Pressure is calculated by multiplying the Maximum Probable Lot Mean (MPLM) service pressure by a factor of 1.40 (i.e., 140%) and rounding **DOWN** to the nearest multiple of 500 psi.
- The Proof Maximum Extreme Variation (EV) is calculated by multiplying the Proof Standard Deviation (which in the case of Rimfire is equal to the Service Standard Deviation) by the constant 5.16⁽⁵⁾ and rounding **UP** to the next 100 psi.
- The Minimum Proof Individual (MPI) pressure is positioned three standard deviations (proof) below the Minimum Average Definitive Proof Pressure, with the calculated value being rounded **DOWN** to the next multiple of 100 psi.

Example:

Cartridge: 22 Long Rifle MPLM Pressure = 24,600 psi S.D. = 960 psi

1. Min. Avg. Proof Pressure = Maximum Probable Lot Mean Pressure x 1.25
i.e.: 24,600 psi x 1.25 = 30,750 psi rounded **up** to next 500 psi = 31,000 psi
2. Max. Avg. Proof Pressure = Maximum Probable Lot Mean Pressure x 1.40
i.e.; 24,600 psi x 1.40 = 34,440 psi rounded **down** to next 500 psi = 34,000 psi
3. Max. Proof E.V. = Service Standard Deviation x 5.16.
i.e.: 960 psi x 5.16 = 4,954 psi rounded **up** to next 100 psi = 5,000 psi.
4. Minimum Proof Individual = Min. Avg. Proof Pressure – (3 x $\sigma_{(PROOF)}$)
i.e., 31,000 psi – (3 x 960 psi) = 28,120 psi rounded **down** to next 100 psi = 28,100 psi

⁵ The Maximum Proof Pressure EV is a statistic derived from knowledge of the population standard deviation. Applying table figures from Relative Range Tables (Biometrika Tables for Statisticians), we calculate the maximum EV, or *Range*, equal to the population S.D. times the table constant 5.16 (for a sample of 10 at 99.0% confidence level).

PROOF PRESSURE DATA - TRANSDUCER

Cartridge	Bullet Weight (grains)	SERVICE Maximum Average Pressure (psi/100)	Pressure Values of Proof Cartridges ⁽¹⁾		
			Minimum Average (psi/100)	Maximum Average (psi/100)	Maximum E.V. (psi/100)
17 Mach 2	17	240*	310	340	50
17 Hornady Magnum	17	260*	335	370	54
17 Winchester Super Magnum	25	330	425	470	69
22 Long Rifle	40	240*	310	340	50
22 Winchester Rimfire	45	200*	255	285	41
22 Winchester Magnum	40	240*	320	355	124

(1) – For sample sizes $\eta=10$.

* No specific recommendation is made as to proof testing Rimfire firearms designed for average service pressures at or below 26,000 psi.

PROOF LOAD SUPPLY

NOTE: Refer to page 55, *Supplier Contact Information*, for detailed information on contacting the manufacturers of listed products and the SAAMI Technical Office.

Rimfire Definitive Proof Loads should be used for one purpose only: the proof testing of rimfire firearms.

A list of current suppliers may be obtained from the SAAMI Technical Office.

PROOF CARTRIDGE IDENTIFICATION

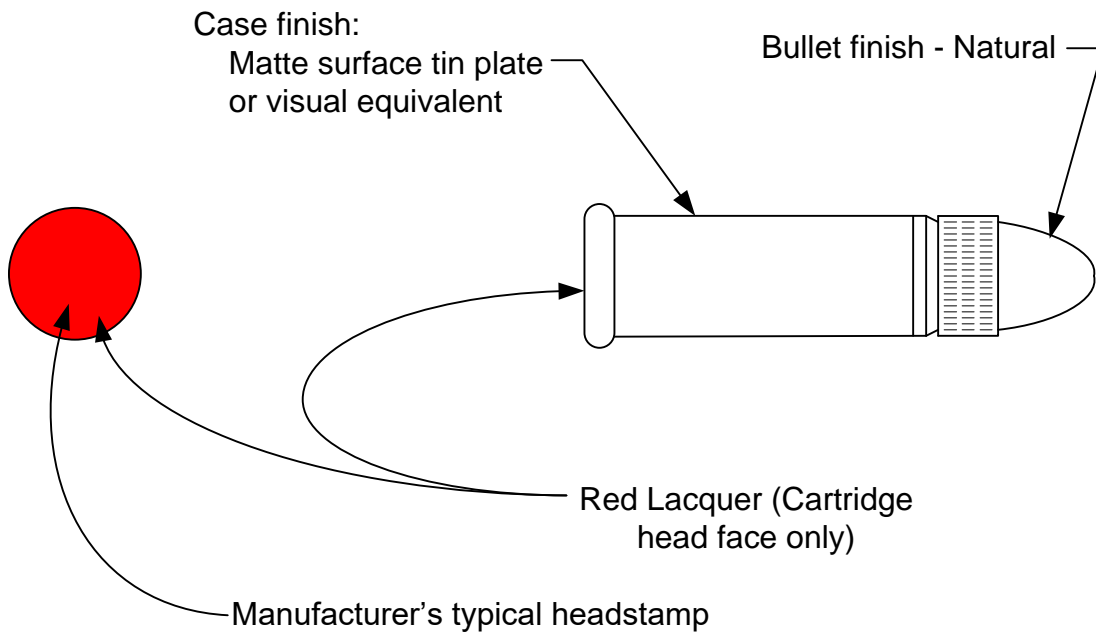

NOTE:

(XX.XX) = Millimeters

DEFINITIVE PROOF PACKAGE IDENTIFICATION

HIGH PRESSURE PROOF LOADS

For Gun Manufacturers' Proof Test Use Only: Fire only from fixed rest with operator properly protected from injury should the firearm be damaged. Purchaser should restrict proof loads to manufacturing premises. To dispose of proof loads, contact producer for instructions.

Rimfire proof loads are identified by a tin-plated case (or visual equivalent) with red lacquer on the case head face.

For consistent results, proof loads should be stored for 2 weeks at $70^{\circ}\text{F} \pm 5^{\circ}$ ($21.1^{\circ} \pm 2.8^{\circ}\text{C}$), and 60% relative humidity before use.

"WARNING: KEEP OUT OF REACH OF CHILDREN"

(Red lettering on white background)