

# ★ National African-American History Month ★

## African American Transportation Leaders and Innovators

February 2018

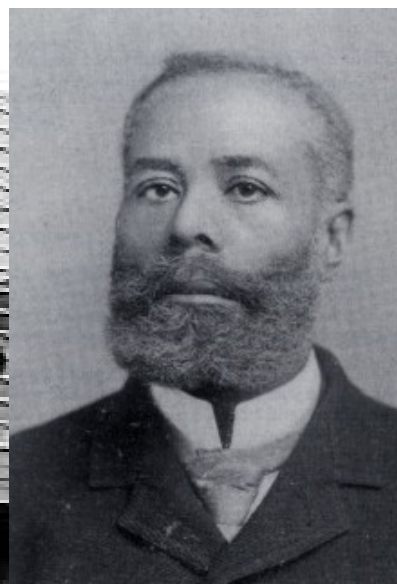
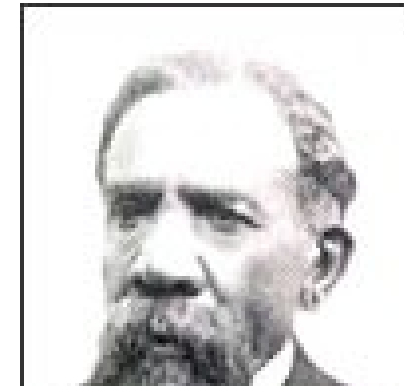
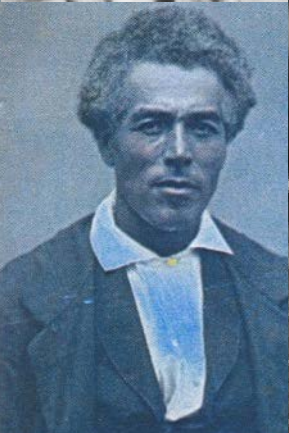

# African American Transportation Innovators

---

- Knowledge of history can inspire us all to greater heights, give us examples to follow, goals to reach, and pride in our legacy
- Among CUTR's important goals is to continue to attract a talented and diverse workforce and to encourage our employees' achievements
- As we celebrate African American History Month we honor those who have made great contributions to many aspects of the transportation industry

# Archibald Alexander (1888–1958)

- Design and Construction Engineer
- Civil Engineering Degree from Iowa State University 1912
- Designed and K Street Freeway in Washington DC
- Formed general contracting business specializing in steel and concrete bridges.
- Built airfield in Tuskegee, Alabama
- First Republican Territorial Governor of the Virgin Islands, 1954-1955
- Honorary Civil Engineering Degree, University of Iowa.
- NAACP Spingarn Medal 1928
- Trustee of Tuskegee Institute
- Honorary Doctor of Civil Engineering, Howard University



# Lawrence Bailey (1918–1998)

---

- First black member and officer of the New York City Metropolitan Transportation Authority
- Lawyer and longtime resident of Jamaica, Queens



# David Baker

- Patented interliners that prevent tire punctures 1924 (1,620,054)
- Patented railway signal apparatus 1913 (1,054,267)
- Patented high water indicator for bridges 1915 (1,154,162)

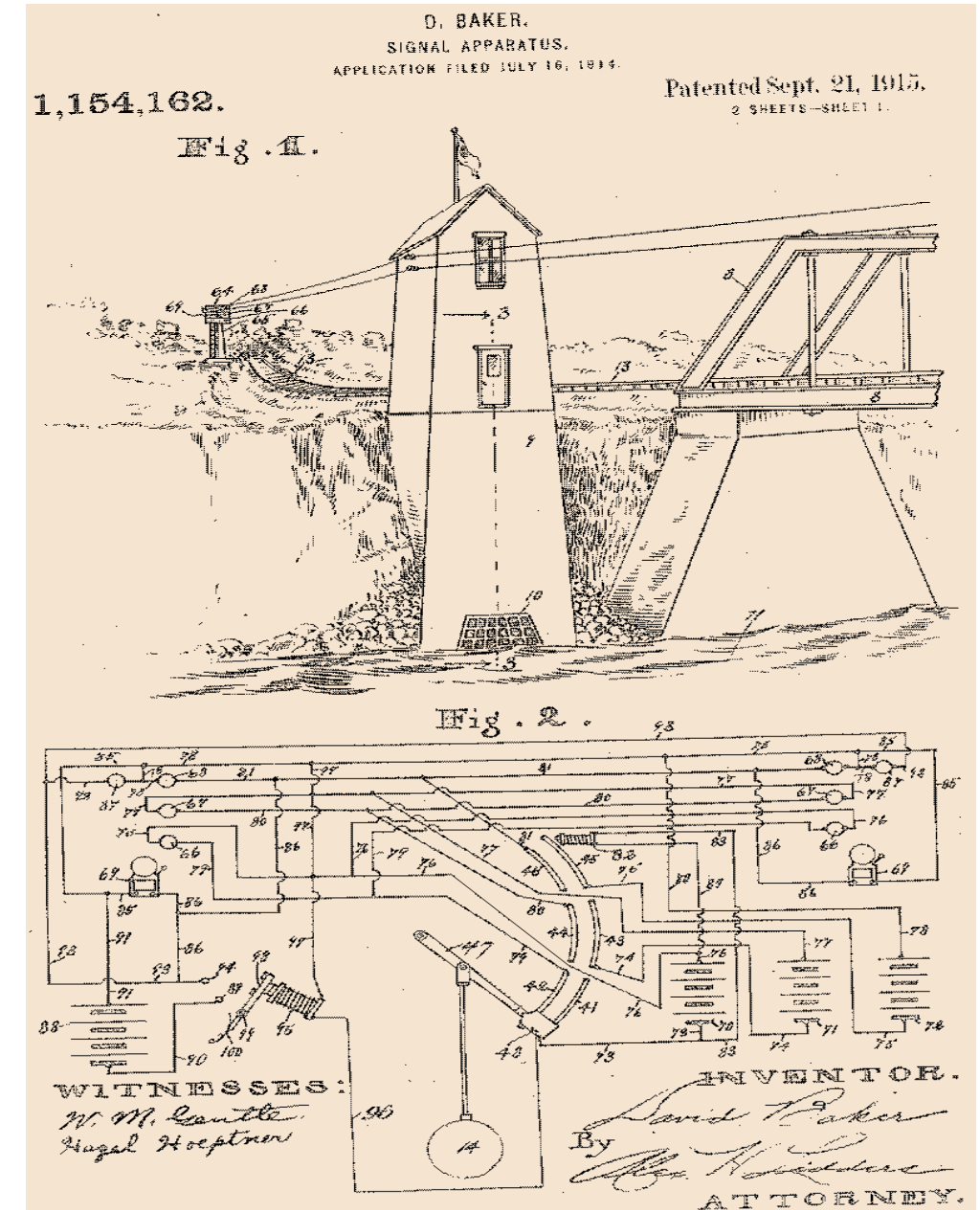
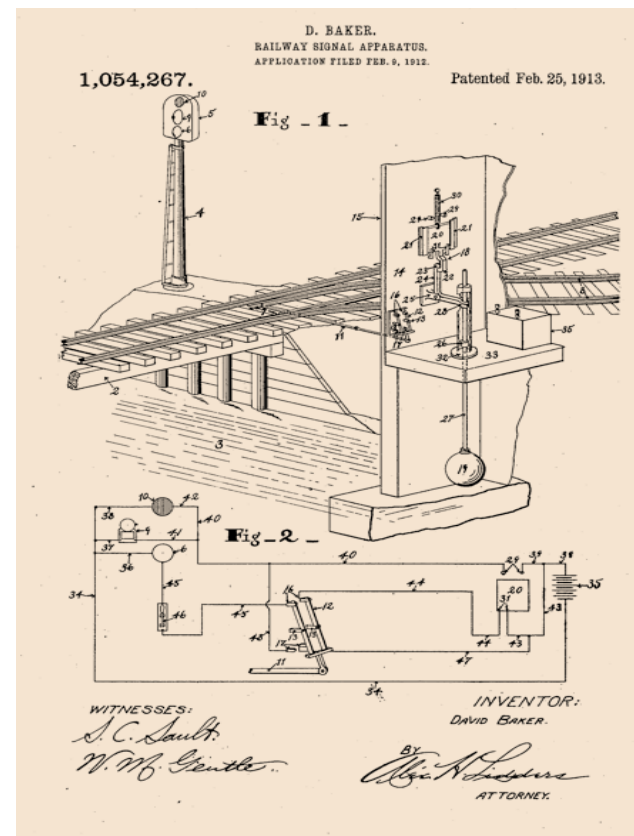
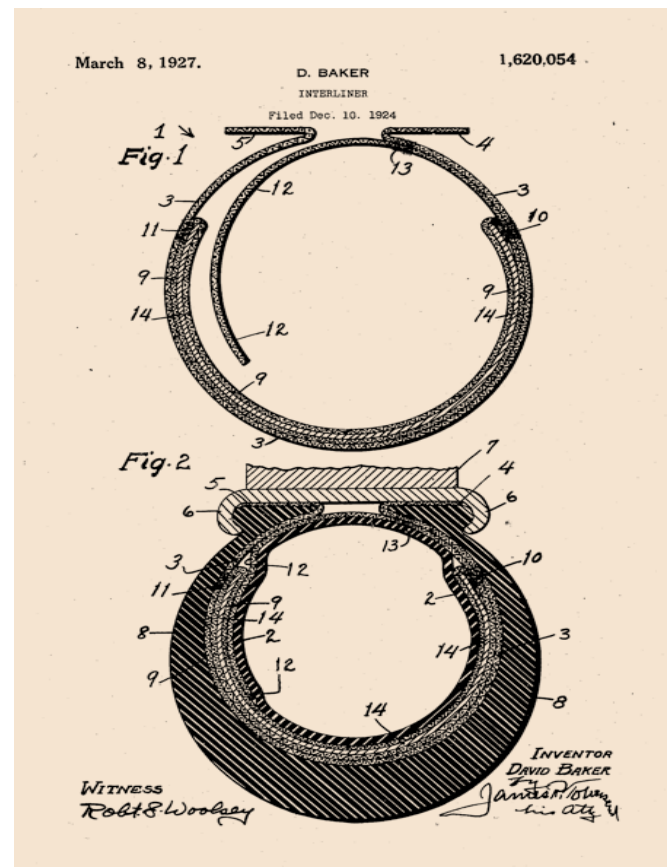

# Sharon D. Banks (1945–1999)

---

- General Manager, AC Transit (Alameda-Contra Costa County, California) during 1990s
- Began AC Transit career as general counsel
- Remembered for “humanistic touch”
- Chair of California Transit Association
- Chair of TRB Executive Committee
- Named “Special Transportation Employee” by Metropolitan Transportation Commission
- WTS offers Sharon D. Banks Scholarship



# Andrew Jackson Beard (1849–1921)

- Born a slave on a plantation in Woodland, Alabama,
- Patented two plows and established real estate business
- Patented rotary engine 1892
- Injured in rail car coupling accident
- Patented “Jenny Coupler” for railroad cars that automatically joined cars by allowing them to bump into each other 1897
- Eliminated dangerous job of manually connecting train cars
- President Benjamin Harrison signed the Safety Appliance Act, which made automatic couplers and air brakes mandatory on all trains 1893

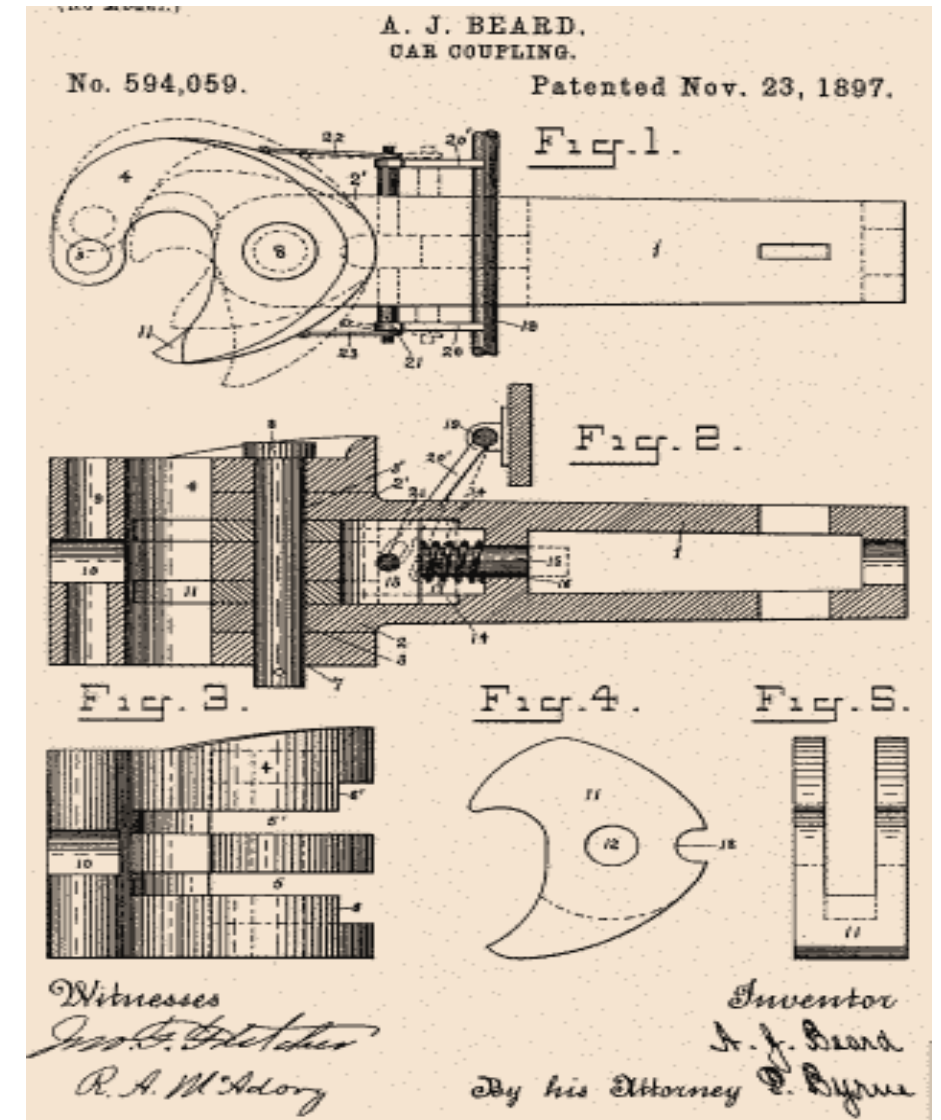

# Landrow Bell

- Patented a safer smokestack for steam train engines 1871
- Helped prevent fires caused by flying sparks and cinders from small smoke stacks

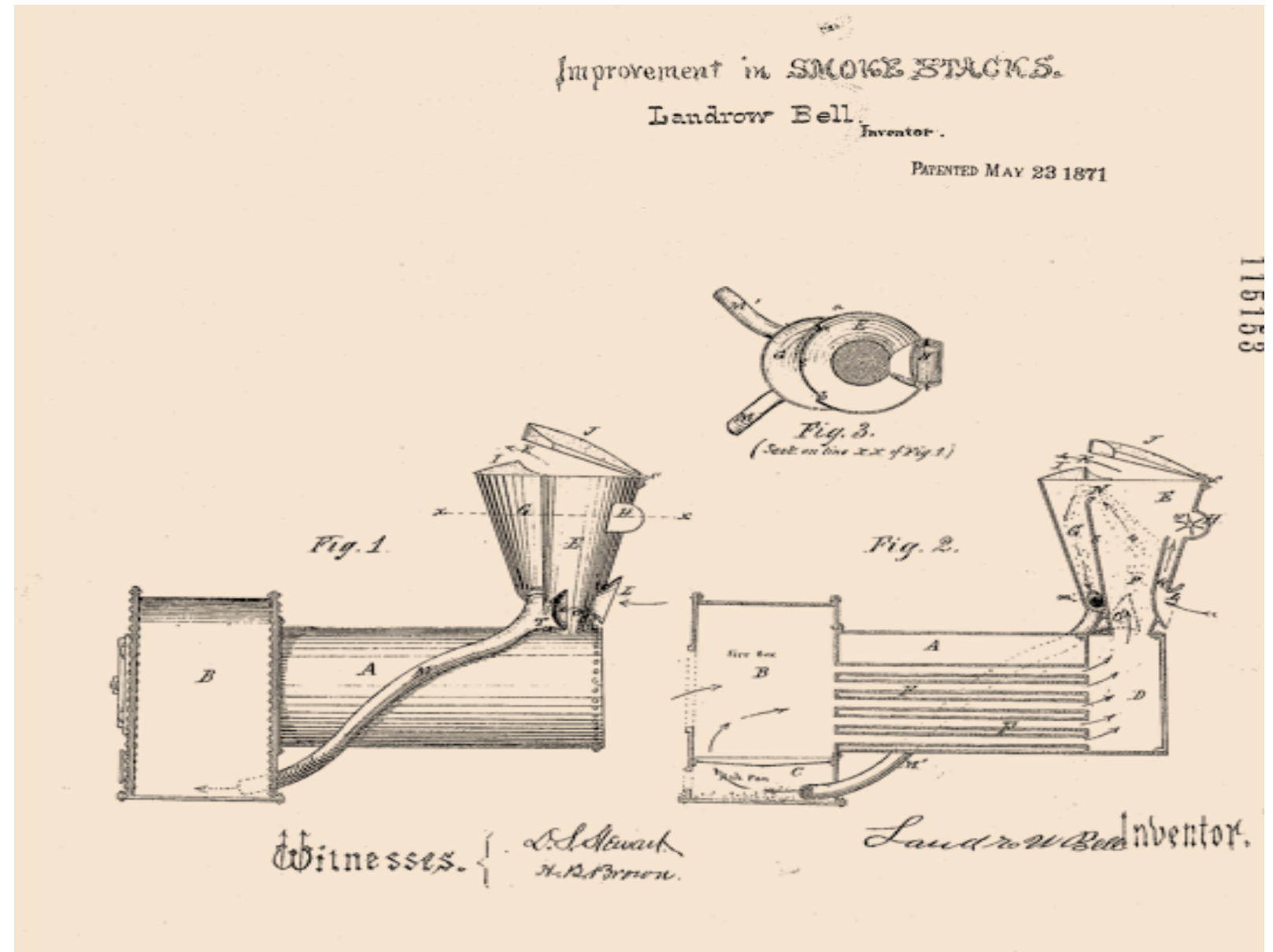



# Edmond Berger

---

May have invented a spark plug for an internal combustion engine 1839



# Charles B. Brooks

- Patented improvements to street sweeper 1896
- revolving brushes attached to the front fender and the brushes were interchangeable with scrapers that could be used in winter for snow removal.

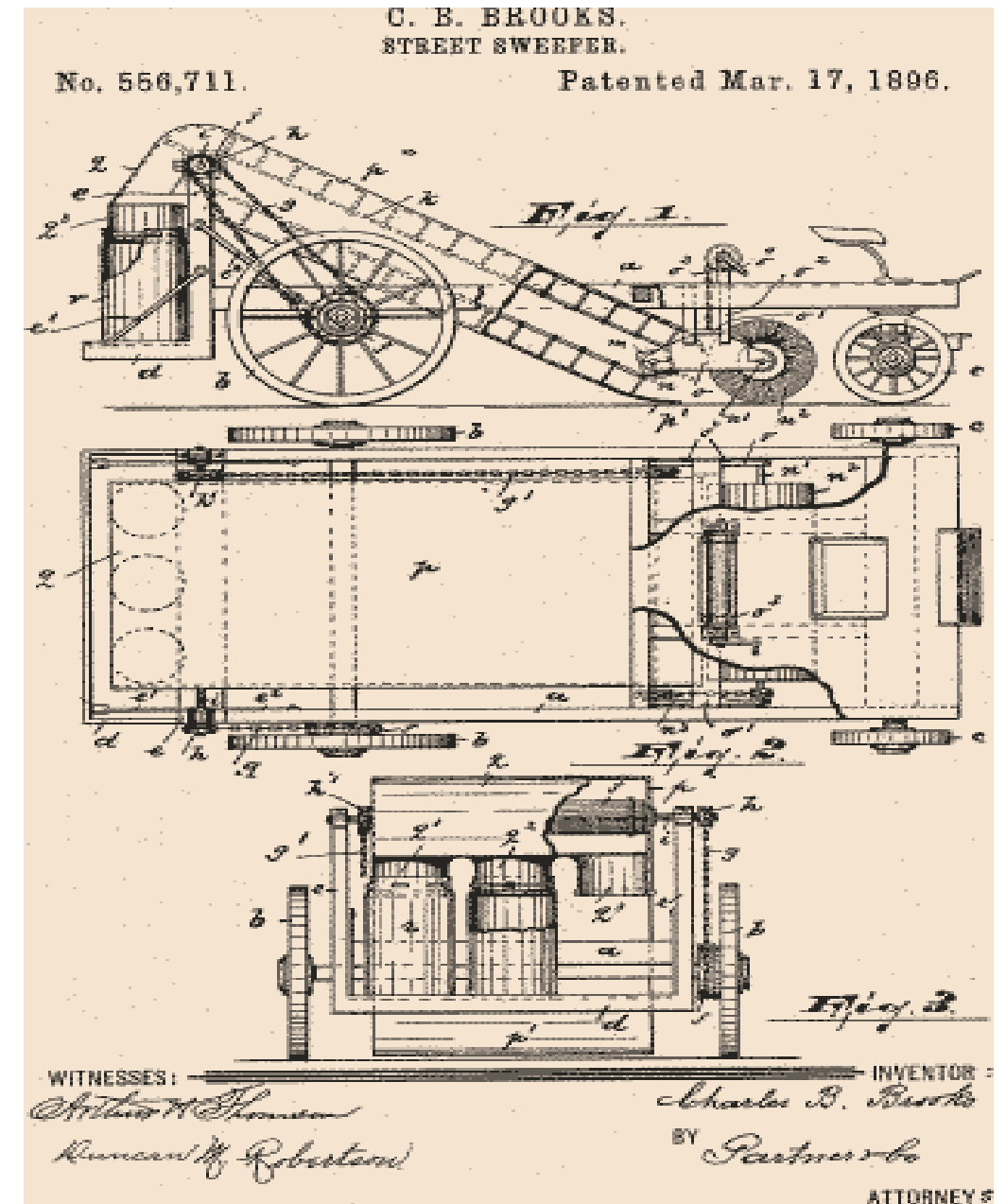

# Bessie Coleman (1892–1926)

- First African-American female pilot 1921
- Earned license from Fédération Aéronautique Internationale on June 15, 1921
- Taught other black women to fly, gave lectures and performed at flying exhibitions



# William Thaddeus Coleman, Jr. (1920–)

---

- Born Philadelphia, Pennsylvania
- Appointed as fourth United States Secretary of Transportation by President Gerald Ford on March 7, 1975
- Served until January 20, 1977
- Second African American to serve in the Cabinet
- During DOT tenure, National Highway Traffic Safety Administration automobile test facility commenced operations in East Liberty, Ohio, and Materials Transportation Bureau established to address pipeline safety and safe shipment of hazardous materials
- Distinguished lawyer who played a major role in significant civil rights cases



# Matthew A. Cherry

- Patented a bicycle 1888
- Patented street-car fender 1895

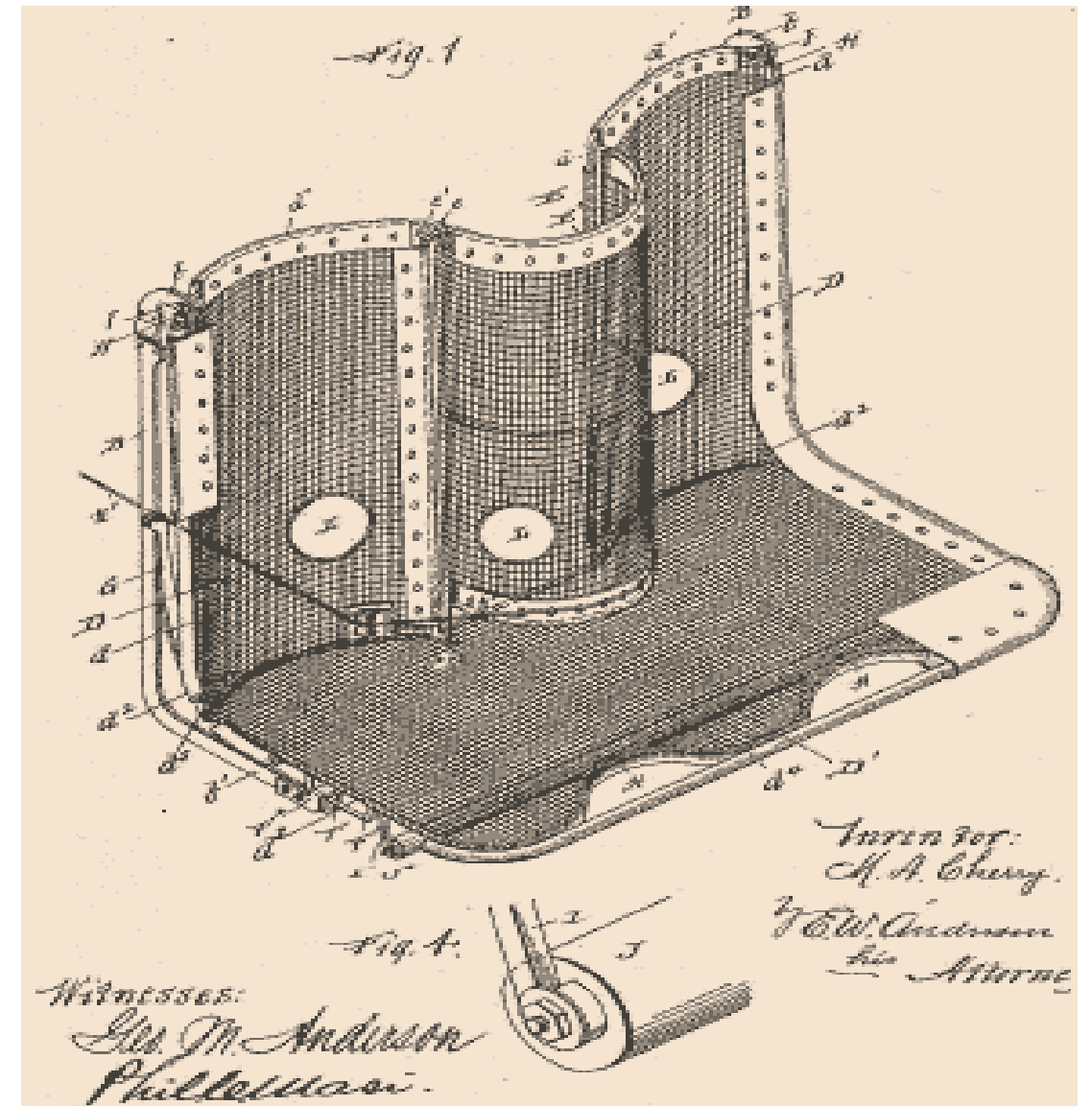
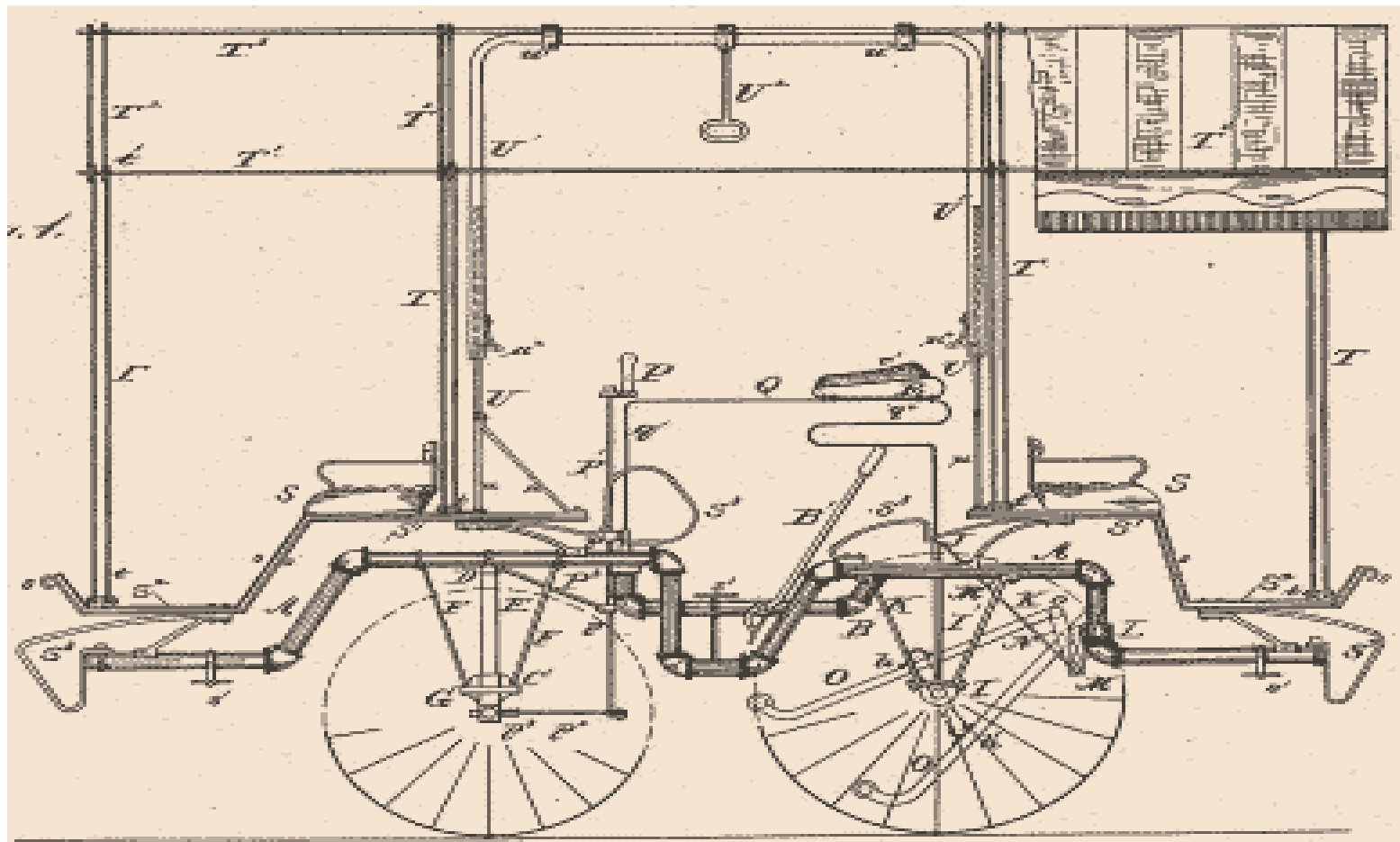

# Shirley A. DeLiberio

---

- More than 30 years of experience in the transportation industry
- President and CEO of Houston METRO
- Project manager and superintendent of Green Line at the Massachusetts Bay Transportation Authority.
- Director of Bus Services and Assistant General Manager at Washington Metropolitan Area Transit Authority (WMATA)
- Deputy Executive Director of Dallas Area Rapid Transit
- Executive Director of New Jersey Transit
- Chair, Conference of Minority Transportation Officials (COMTO)
- First African-American woman Chair of American Public Transportation Association (APTA)
- APTA Hall of Fame 2006
- COMTO Thomas G. Neusom Founder's Award, Distinguished Leadership Award in Transportation, Outstanding Community Service Award, and Lifetime Achievement Award
- Top 10 Women in U.S. Government, Good Housekeeping Magazine
- Top Public Officials of the Year, Governing Magazine



# Nuria Fernandez

---

- Over 25 years of professional experience
- B.S. Civil Engineering, Bradley University and M.B.A., Roosevelt University
- Commissioner of Aviation, City of Chicago
- Senior Vice President, Earth Tech
- Acting Administrator and Deputy Administrator, Federal Transit Administration, U.S. Department of Transportation
- Assistant General Manager, Design and Construction, Washington Metropolitan Area Transit Authority
- Senior Vice President, Development and Construction, Chicago Transit Authority
- Assistant Director, Department of Public Works, City of Chicago
- Mineta Transportation Institute Board of Trustees
- Northeast-Midwest Institute Board of Directors
- Women's Transportation Seminar Advisory Board



# Gary Gayton (1933–)

---

- Special Assistant to the United States Secretary of Transportation, Brock Adams, 1977
- Department of Transportation's White House Liaison
- Acting Administrator of the Urban Mass Transportation Administration
- wrote the Department Minority Business Enterprise and Women Business Enterprise Programs
- Interagency Committee on Women Business Enterprise

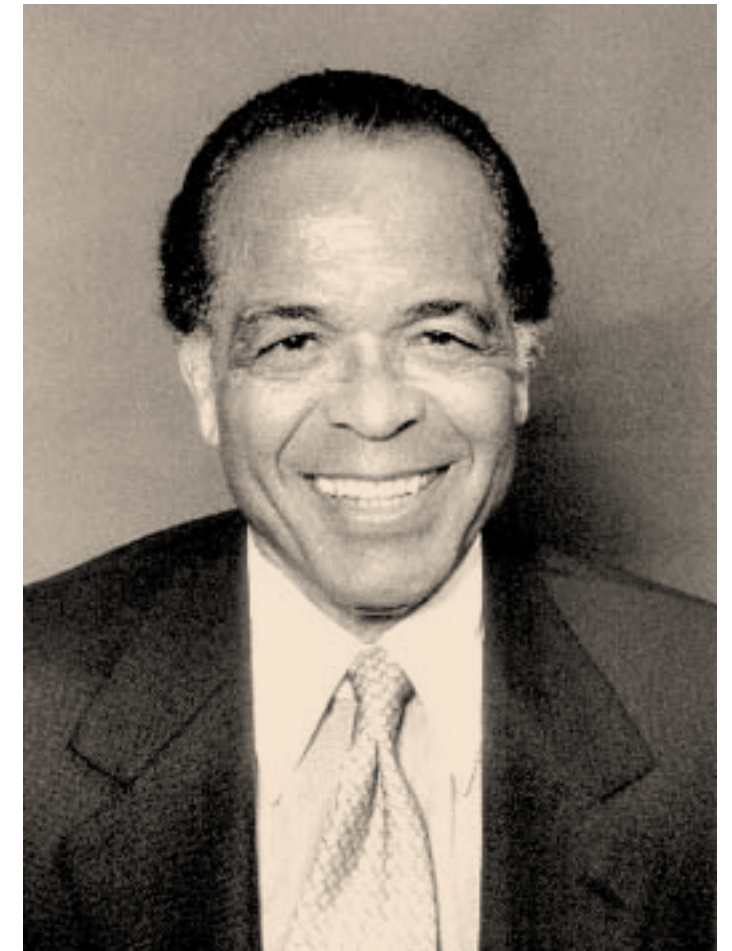



# Ralph Gilles (1970–)

---

- Born New York, NY
- Automobile designer
- Vice President of Design at Chrysler LLC
- Joined Chrysler 1992
- Styled the 2005 Chrysler 300
- Attended College for Creative Studies in Detroit, Michigan
- Received Executive MBA from Michigan State University 2002



# Meredith C. Gourdine (1929–1998)

- Born Newark, NJ
- B.S. Engineering Physics, Cornell University 1953
- Ph.D. California Institute of Technology 1960
- National Academy of Engineering 1991
- Olympic silver medalist in long jump, Helsinki 1952
- Patented Method for Airport Fog Precipitation 1987 (4,671,805)
- Black Inventors' Hall of Fame
- President Johnson's Advisory Panel on Energy

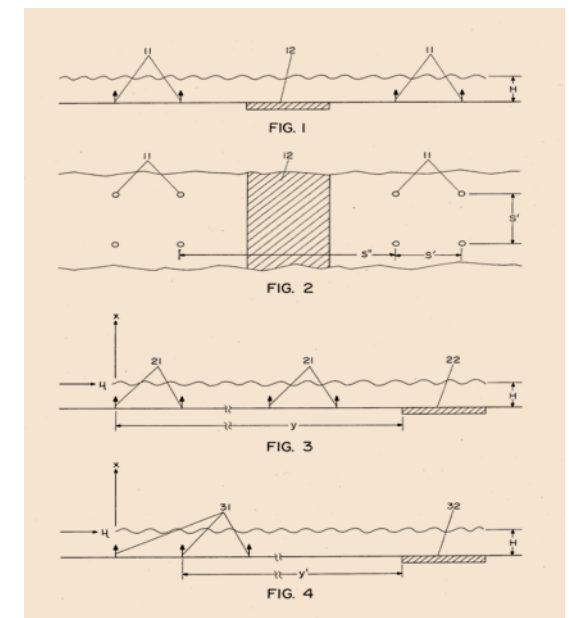

# Hampton D. Haith

---

- Last general manager of Safe Bus Company, Winston-Salem, North Carolina
- Safe Bus Company became the largest African-American owned transportation system in the United States
- Safe Bus Company formed in 1921 by a group of African-Americans who owned jitneys
- Company served routes in East Winston until it expanded to cover the entire city in 1968
- Haith eased the bus system's transition to integration and city ownership in the early 1970s
- One of the last buses purchased by Safe Bus Company, a 1960s GMC, was still in operation when Winston-Salem Transit Authority (WSTA) took over the operation
- Today, WSTA buses operate out of the Hampton D. Haith Public Transportation Center at 1060 N. Trade Street
- Haith retired in 1978 and died in 1993



# Willie James (1936–2009)

---

- First African American president of the New York City bus and subway workers union (Transport Workers Union Local 100)
- Bus Operator in the Manhattan and Bronx Surface Transit Operating Authority
- First minority officer in Local 100's MaBSTOA division in 1972 as the Bronx division recording secretary
- Remembered as a pioneer
- Raised in Harlem, served in the military and was a police officer before becoming a bus driver in 1967
- Held several union positions, including training director and secretary-treasurer
- Served on board of directors of the Municipal Credit Union and New York branch of the NAACP



# Albert William Johnson (1920–)

---

- First African American General Motors franchisee (Oldsmobile), Chicago 1967
- Cadillac dealership 1971
- Entrepreneurship Hall of Fame and Man of the Millennium, University of Illinois School of Business.
- Born in St. Louis
- B.S. Business Administrator, Lincoln University 1940
- M.S. Hospital Administration, University of Chicago 1960
- Assistant administrator of a St. Louis teaching hospital
- Founder of the PUSH Foundation
- Life member of the NAACP
- Honorary doctorate of law from Mary Holmes College
- Honor of Entrepreneurial Excellence from Howard University School of Business Administration



# Isaac R. Johnson

Patented bicycle frame which can be separated or folded, 1899

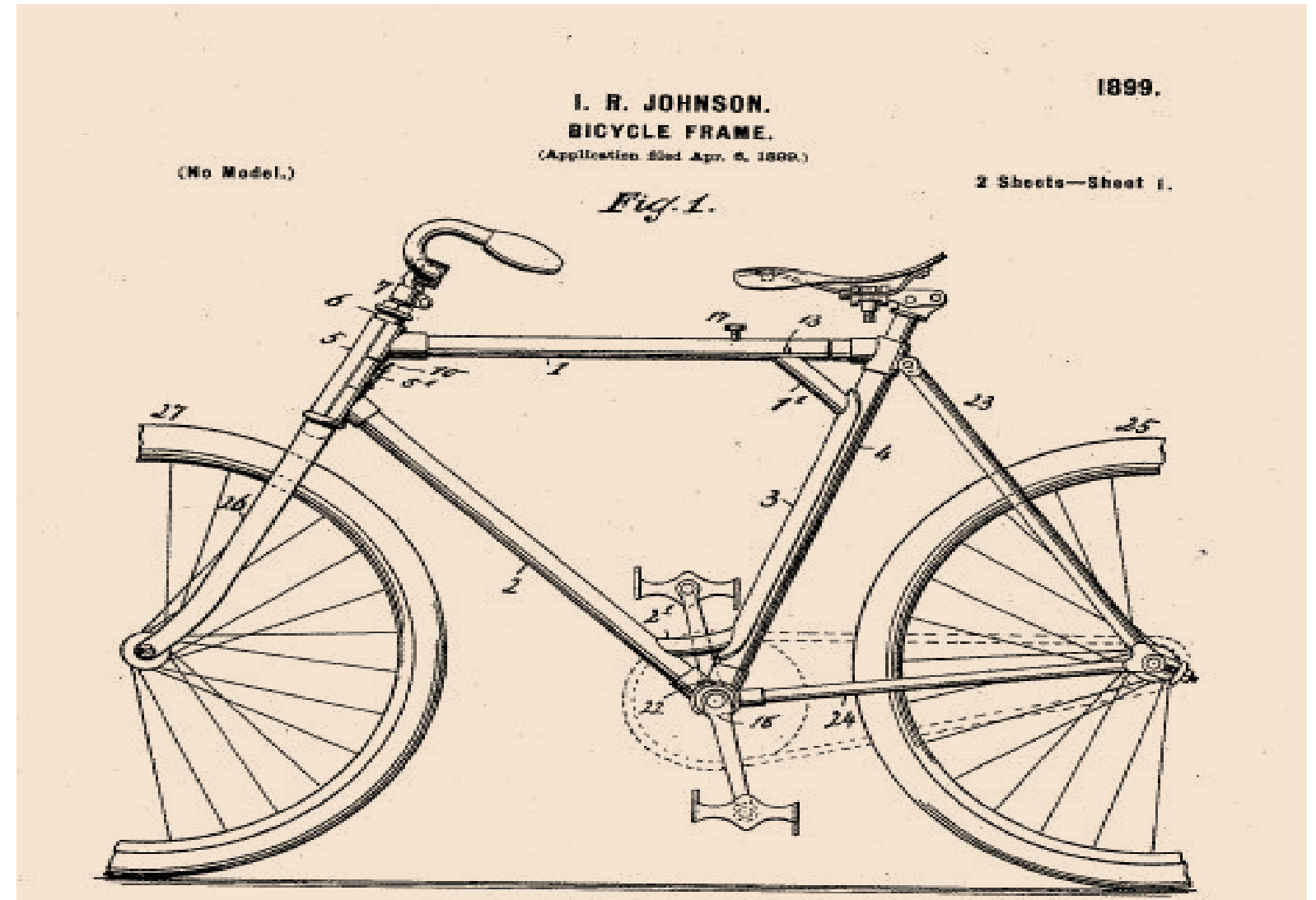

# Jack Johnson

- Born 1878 Galveston Texas
- Professional boxer 1897–1928
- Patented Theft-Preventing Device for Vehicles 1922 (1,438,709)
- Interferes with fuel flow of internal combustion engines and could be used for boats and airplanes as well as cars

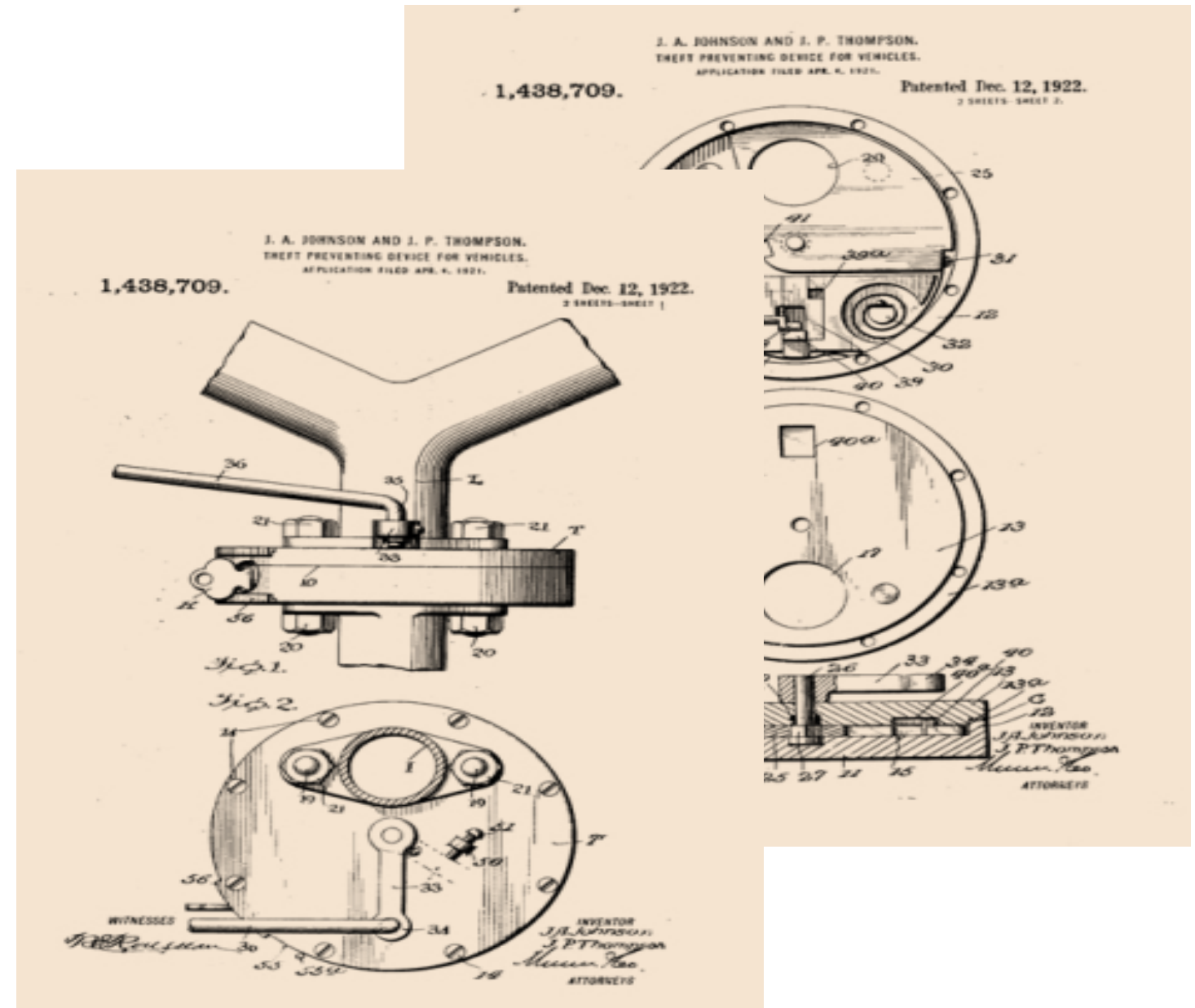
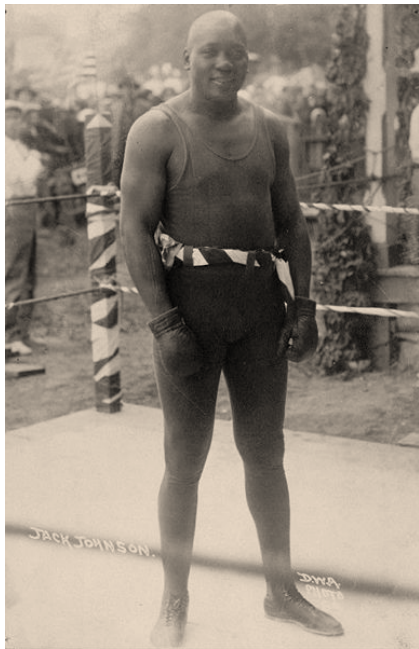

# Minnie Fells Johnson, Ph.D.

---

- Has held several high-level management posts in Montgomery County, the State of Ohio and Broward County, Florida
- All of her positions have been as the first African American or female or both
- Former Executive Director, Greater Dayton Regional Transit Authority (previously the Miami Valley Regional Transit Authority)
- Chaired National Job Access Task Force for the American Public Transportation Association
- Named one of Dayton's Top Ten Women
- Named Outstanding Black Woman by Sinclair Community College Student Government
- National Association of Counties County Achievement Award
- Outstanding Women of the Year, Women in Communications—Government, and Governor's Proclamation, State of Ohio





# Frederick McKinley Jones (1893-1961)

- Patented automatic refrigeration system for long-haul trucks and rail cars to aid in transport of perishable food 1940 (2,303,857)
- Patented gas engine starter and control device for internal combustion engines
- More than 60 patents
- Born in Covington, Kentucky
- Trained as a mechanic
- Military service in France, World War I

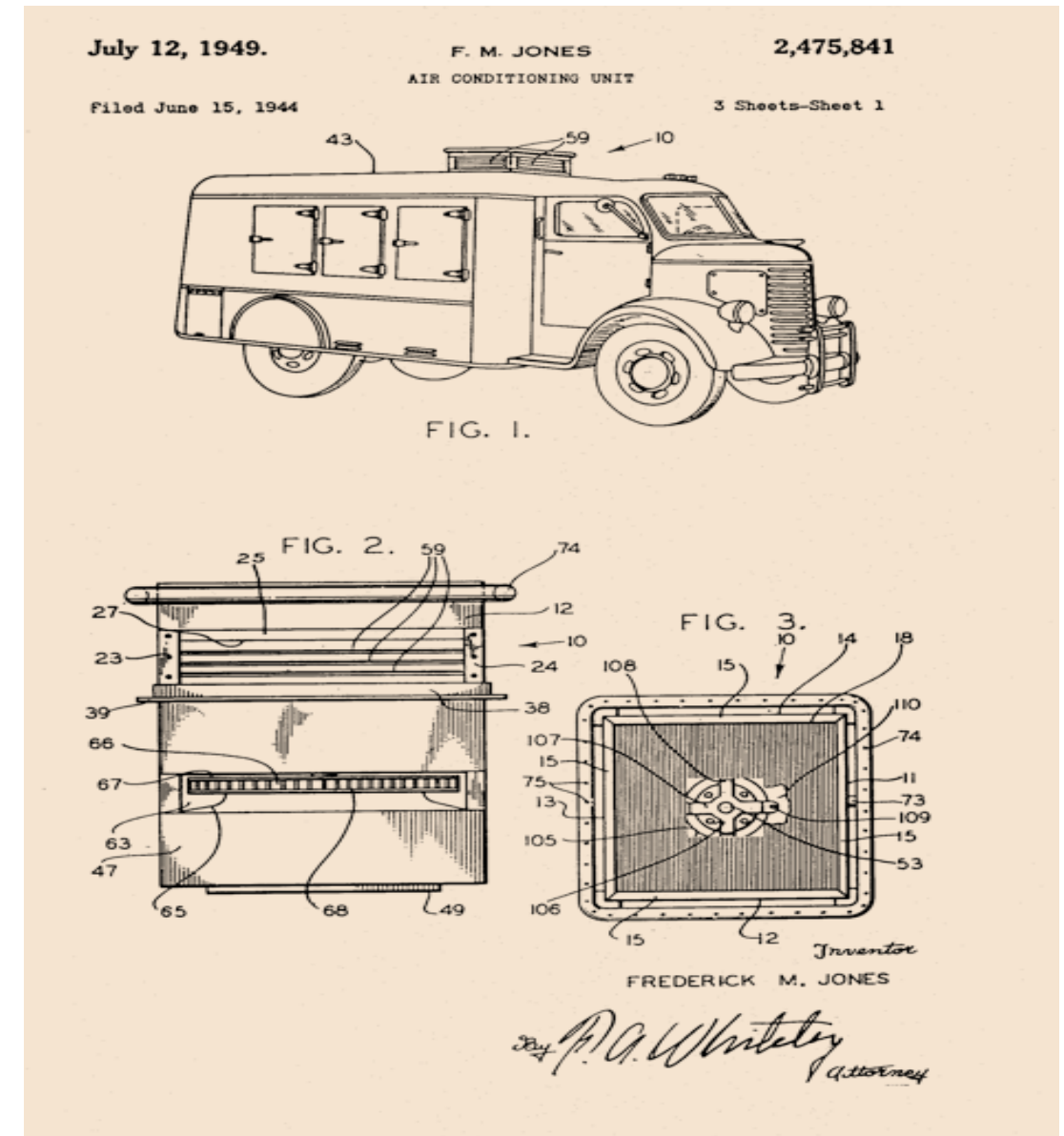

# Horace King (1807-1887)

---

- Slave who was freed by his master in 1846
- Became one of the most respected bridge builders in Georgia, Alabama and Mississippi during the nineteenth century
- Rebuilt bridges in South Carolina and Alabama
- Passed his legacy to his children through the family business
- Represented Russell County in the Alabama legislature 1868–1872



# Washington W. King (1843–1910)

- Son of Horace King, built many bridges in Georgia
- Repaired and replaced large and small crossings
- Rebuilt the crossing into Alabama at Fort Gaines, Gain 1888—the bridge that his father had built in 1868



# Naomi Ledé, Ph.D.

---

- Senior Research Scientist with the Texas Transportation Institute
- Recognized as an African-American Hero in Transportation by Port of Houston Authority
- Specialist in the fields of intelligent transportation systems and transportation planning
- Has served in faculty and administration positions at Texas Southern University since 1982
- Holds degrees from Mary Allen College, Texas Southern University, the University of Texas at Arlington and the University of Houston



# Jan Ernst Matzeliger (1852–1889)

- Born in Paramaribo, Dutch Guyana (now Suriname)
- Settled in Philadelphia, Pennsylvania at 19 after working as a sailor
- Patented shoe lasting machine in Massachusetts, 1883
- Machine would speed up the production of shoes from 50 pairs per day to between 150 to 700 pairs of shoes a day
- Cut shoe prices across the nation in half

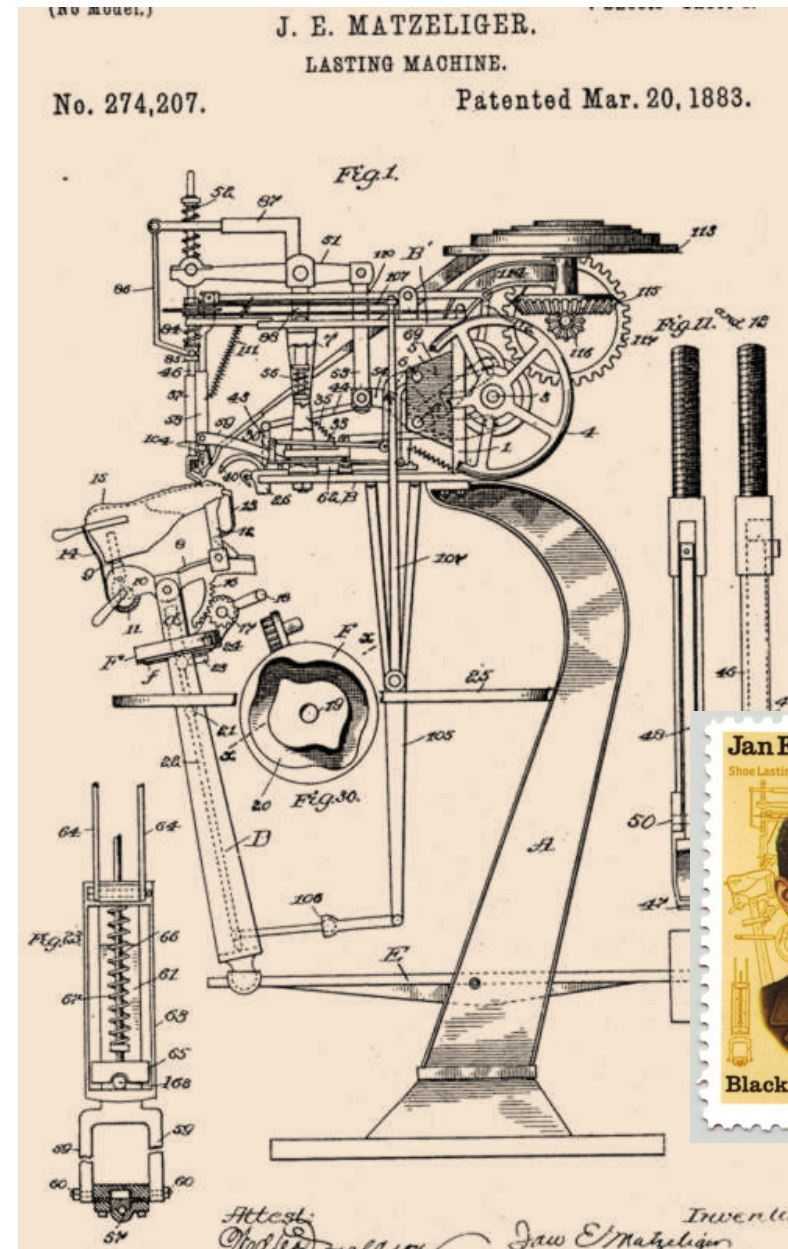

# Elijah J. McCoy (1843–1929)

- Studied engineering in Edinburgh, Scotland
- Fireman and oiler at the Michigan Central Railroad
- Patented an automatic lubricator for oiling the steam engines of locomotives and boats, “Improvement in Lubricators for Steam-Engines” (129,843), 1872
- Lubricators allowed trains to run faster and more profitably with less need to stop for lubrication and maintenance
- Recognized in 1909 as having produced more patents than any other black inventor up to that time
- Obtained 57 patents mostly related to lubrication

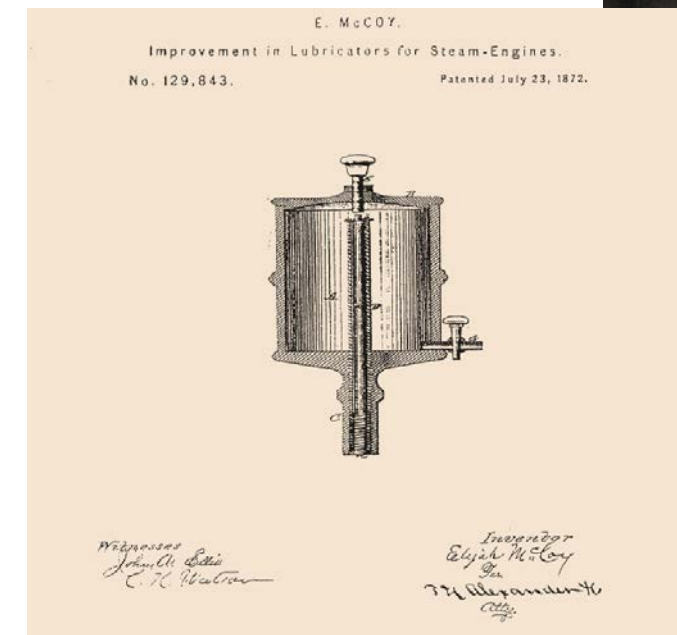
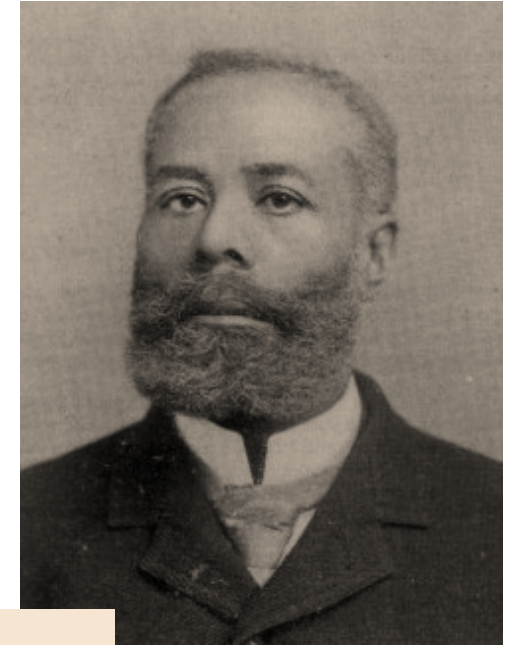

# Alexander Miles

- Patented electric elevator 1887 (371,207)
- Improved method of opening and closing of elevator doors
- created an automatic mechanism that closed access to the shaft

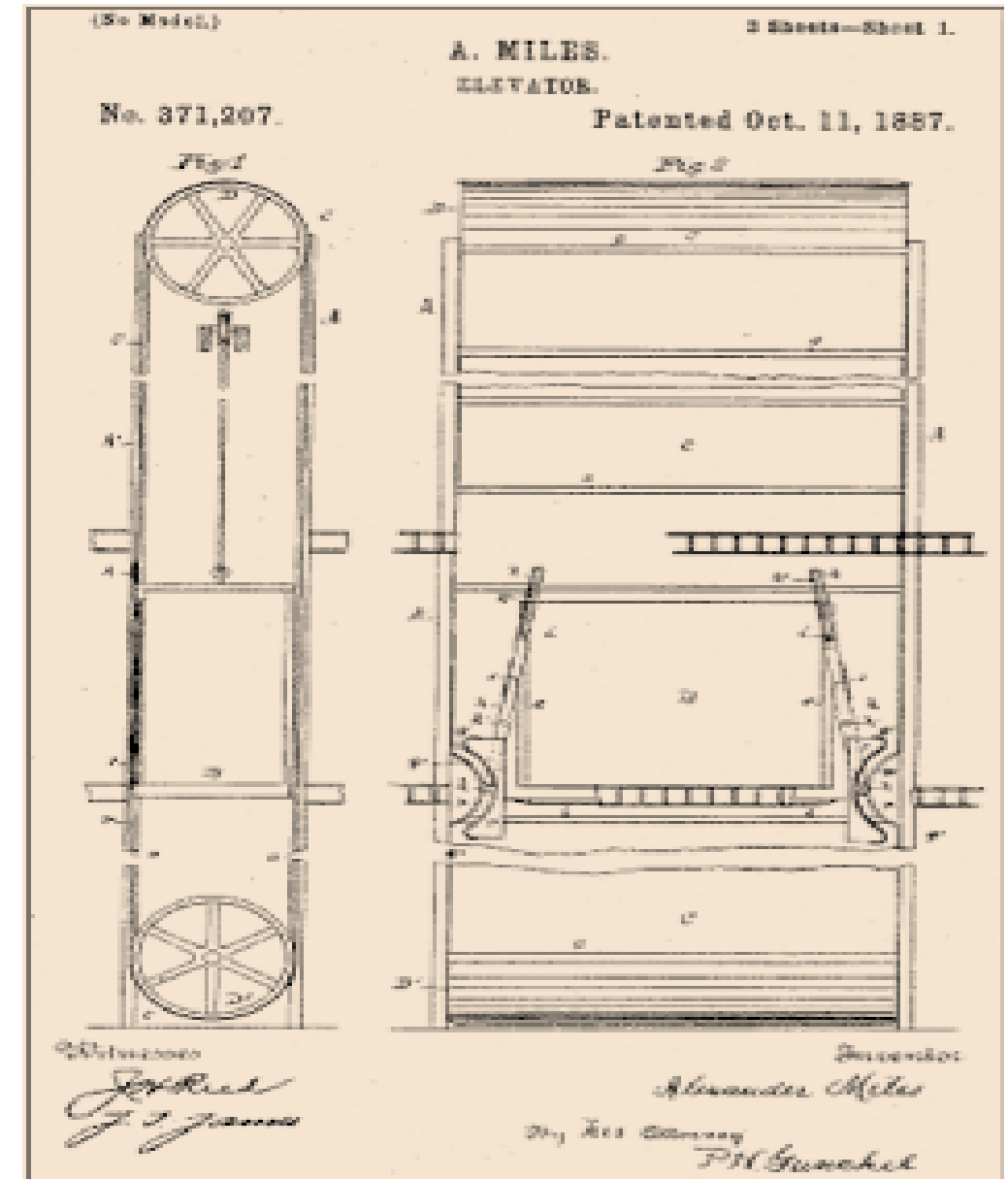

# Samuel Moore

## Patented:

- Self-directing headlight 1926(1,608,903)
- Vehicle-headlight mechanism 1928(1,658,534)
- Locomotive headlight 1928(1,659,328)
- Fuel-valve lock for motor vehicles 1935 (2,006,027)

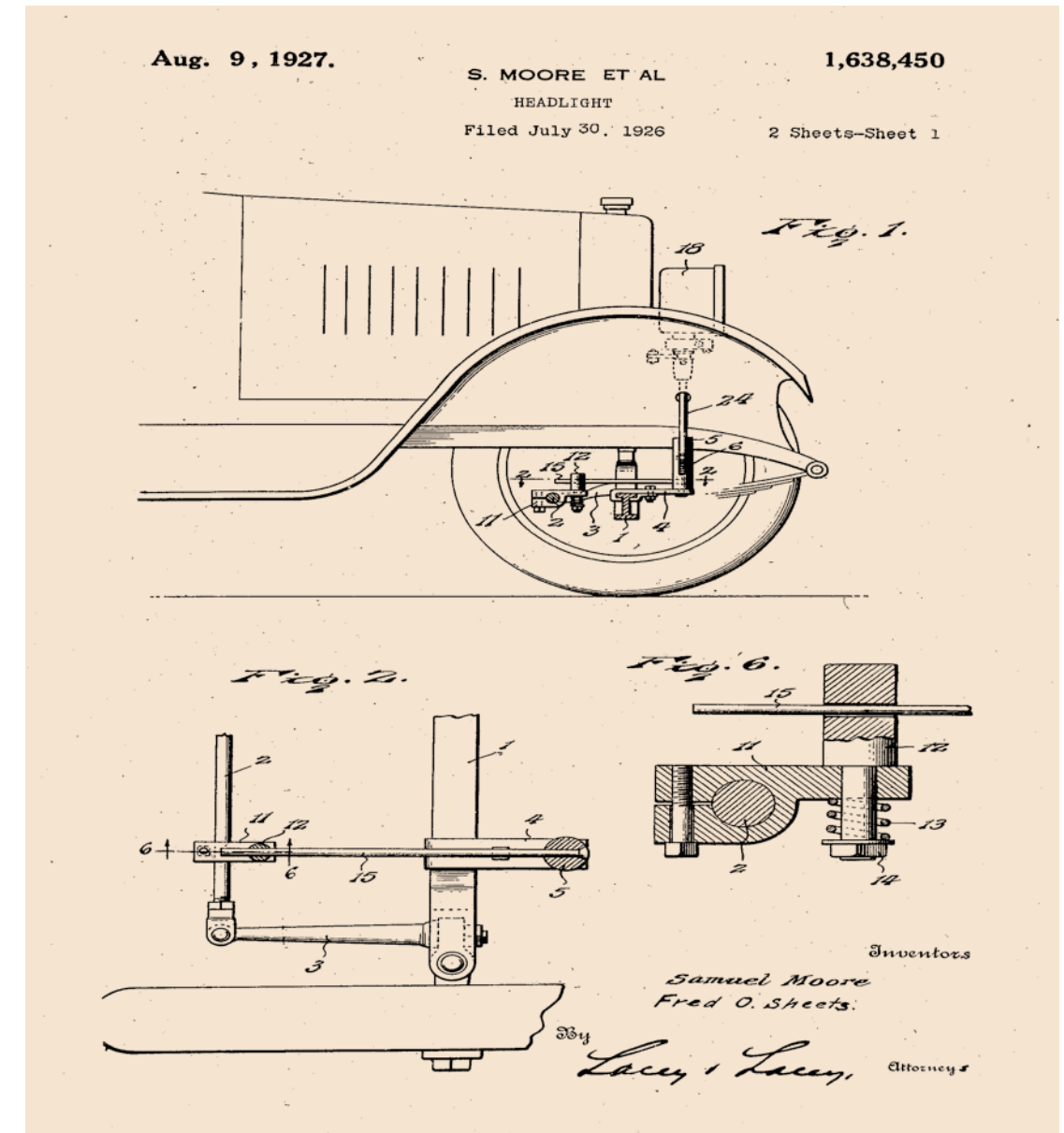



# Garrett Augustus Morgan (1875–1963)

- Born Paris, Kentucky
- Received wide recognition for his outstanding contributions to public safety
- Patented traffic signal to regulate vehicle movement in city areas 1923 (1,475,024)
- GO and STOP signs were systematically raised and lowered at intersections to bring order out of the chaos of regulating pedestrian and vehicle traffic on city streets
- Sold invention to the General Electric Company
- Received patents in England and Canada for similar signal devices

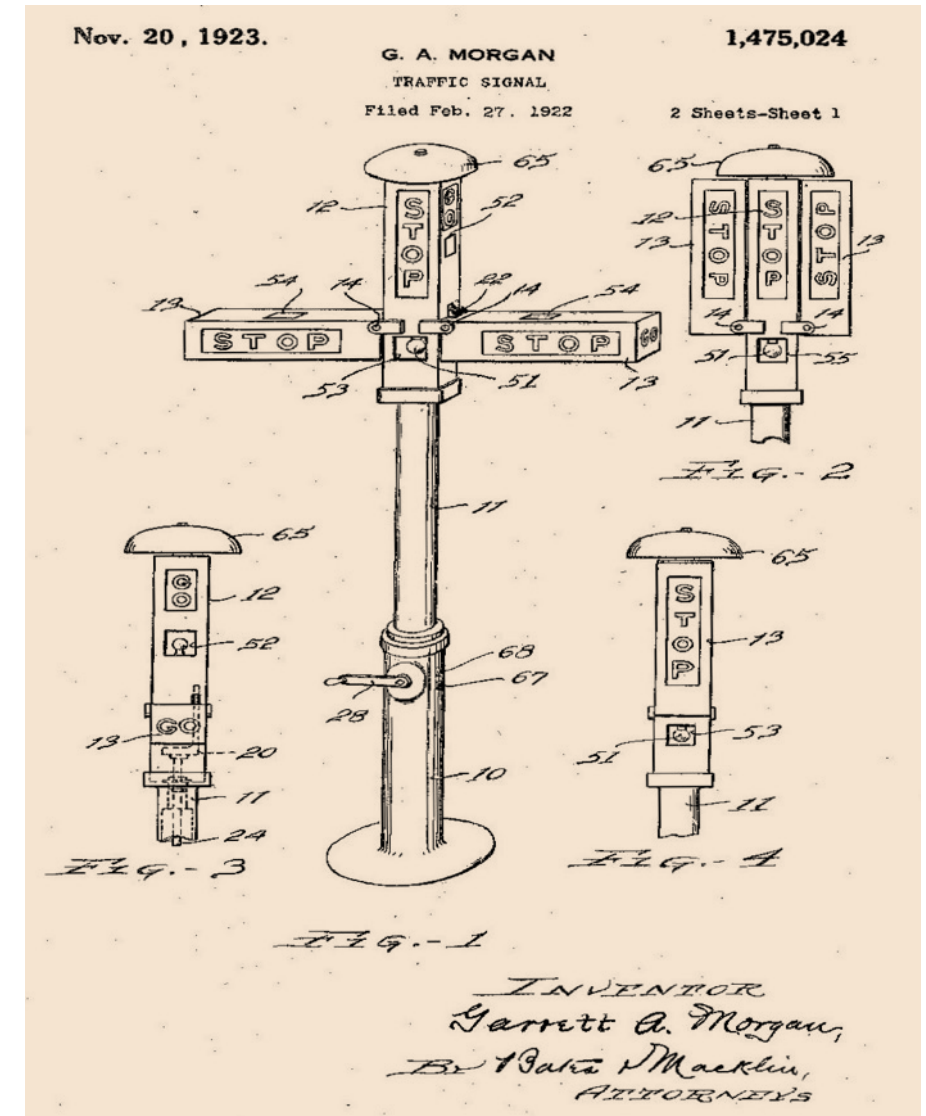

# Hugh Mulzak (1886-1971)

---

- Born in British West Indies 1886
- Attended Nautical School in Swansea, United Kingdom
- Sailed as ship's officer in World War I
- Became U.S. citizen in 1918
- Passed examination as first African American U.S. Shipmaster, 1920
- Worked for 20 years in food service management for various shipping lines
- Named master of new Liberty ship *Booker T. Washington* 1942
- *Booker T. Washington* made 22 round-trip voyages with Mulzac at helm
- Worked as night mate after 1960
- Left a legacy of courage, fierce determination and accomplishment in the face of extreme hardship



# Richard F. Neblett

Patented a formula of gasoline composition and motor fuel composition in 1960

United States Patent Office 2,955,928  
Patented Oct. 11, 1960

1

2,955,928  
GASOLINE COMPOSITION

Warren Maxwell Smith, Baton Rouge, La., and Richard F. Neblett, Elizabeth, N.J., assignors to Esso Research and Engineering Company, a corporation of Delaware

No Drawing. Filed Sept. 11, 1956, Ser. No. 609,062  
5 Claims. (Cl. 44-56)

The present relates to improved motor fuels and methods for making them, particularly to motor fuels containing additive agents adapted to reduce or prevent gum problems in the motor while simultaneously lubricating the moving parts in the upper part of the motor. More particularly, the present invention relates to a gasoline composition containing an improved solvent oil adapted to prevent valve stem and piston ring sticking and serve as a general purpose upper cylinder lubricant.

The use of solvent oils in gasoline compositions to prevent ring and valve sticking and provide upper cylinder lubrication has long been known. Conventional solvent oils are described in U.S. Patent 2,066,234, issued to Sloane and Wasson on December 29, 1936. This patent defines a solvent oil as consisting of a liquid hydrocarbon mixture having a 50% distillation point above 350° F. at 10 mm. Hg pressure, having a Saybolt viscosity at 100° F. not above 450 seconds, and having an A.P.I. gravity of about 18-28°. A typical solvent oil, for example, has the following inspection:

50% distillation point	.....@ 10 mm. Hg--	413
Saybolt viscosity @ 100° F.	.....	75.3
A.P.I. gravity	.....	26.6

In general, the solvent oil concentration in a gasoline may range from about 0.05 to 1.0%.

The solvent oils generally employed are hydrocarbonaceous, and have selective solvent action for hydrocarbon gums, sludges and varnishes. However, oxygenated gums and resin are not readily removed by these solvent oils, and it would be highly desirable to employ as a solvent oil, or as an adjuvant to solvent oils, a composition that has high specificity for gums and varnishes. In the past, various oxygenated solvents have been added to gasoline for this purpose, but these materials have not been wholly effective, either because of too high vapor pressure at motor operating conditions, or because excessive quantities were required. Thus, it has been suggested that high boiling esters such as amyl stearate be employed as a solvent oil. Such esters, however, have not given satisfaction and their solvent powers are inadequate.

The need for a highly active solvent oil type additive has been long recognized. A tendency to cause manifold deposit and intake port deposit buildup represents a serious fuel deficiency, particularly when the fuel is used in low temperature service with considerable engine idling time. Catalytically cracked gasolines which have comparatively high octane numbers and are thus widely used are unstable and require the use of an antioxidant. Both these unstable fuels and antioxidant residues contribute to manifold deposits. Use of a solvent oil type additive represents a desirable method of minimizing these deposits.

It has now been found that excellent solvent oils may be prepared by fortifying conventional hydrocarbon type solvent oils with particular liquid synthesis products derived from the reaction between olefins, carbon monoxide and hydrogen in the presence of a cobalt carbonylation

2

reaction catalyst. The carbonylation, or Oxo reaction as it is commonly called, is well known in the art as a method of preparing alcohols from olefins, the former having one more carbon atom than the olefin from which it is derived. It is a two-stage synthesis wherein, in the first stage, olefins, CO, and H<sub>2</sub> are reacted in the presence of a cobalt catalyst at pressures of about 2000-4000 p.s.i.g. and temperatures of 275° to 375° F. to form an aldehyde product containing one more carbon atom than the parent olefin, and, in the second stage, the aldehyde product is subsequently hydrogenated to form the corresponding alcohol. The process is described in U.S. Patent 2,327,066 to Roelen; in 2,504,682 to Harlan and in many subsequent patents. It is the still pot residues after the distillation of the alcohol fraction, commonly referred to as "Oxo bottoms" that are the solvent oil fortifying components of the present invention. In the carbonylation of a heptene fraction obtained from propylene-butylene copolymerization, for example, the bottoms represent about 15-30% of the crude alcohol charged to the distillation zone. The bottoms consist primarily of highly branched C<sub>16</sub> alcohols, C<sub>24</sub> acetals, C<sub>16</sub> ethers, both saturated and unsaturated, and minor amounts of other oxygenated compounds, such as aldols, esters and the like. A typical analysis of the composition obtained from carbonylation of a heptene polymer fraction is as follows:

	Percent (weight)
C <sub>16</sub> alcohols	48.6
C <sub>24</sub> acetals	19.1
C <sub>16</sub> ethers	17.4
C <sub>22</sub> esters	14.7
C <sub>18</sub> ketones/aldehydes	0.2

Inspection of the product is as follows:

Hydroxyl No.	95
Free carbonyl No.	0.5
Combined carbonyl No.	29
Saponification No.	21
Gravity, ° A.P.I.	33.3
Acid No.	0.2

Though for any particular olefin fraction being carbonylated the magnitude of these constituents may vary, the relative proportions generally remain fairly constant. Thus, a propylene fraction, a heptene fraction, a C<sub>6</sub>= and a C<sub>13</sub>= fraction may be carbonylated and the bottoms employed. The constituents of Oxo bottoms are all characterized by being highly branched, even though relatively straight chain olefins are originally carbonylated. This arises out of the isomerizing characteristics of the cobalt carbonyl catalyst and the fact that the addition of the

$$\begin{array}{c} \text{H} \\ | \\ -\text{C}=\text{C}- \\ | \end{array}$$

group may be to either one of the double bonds.

A sample of a C<sub>8</sub> Oxo bottoms has the following Engler distillation at 10 mm.

Percent distilled:	Temp., ° F.
I.B.P.	184
5	220
10	220
20	234
30	253
40	270
50	308
60	322
70	340
80	370
90	435
95	486
F.B.P. (98%)	503

# 93rd, 95th and 97th Engineer Regiments

- Three black regiments helped build 1,400 mile Alaskan Highway through Canada to Alaska
- Pioneer road completed in 7 months, opened to U.S. Army traffic on November 20, 1942
- Dawson Creek, BC to Fairbanks, AK
- Contributed to nation's mobilization and defense by linking continental U.S. to Alaska



# Neville A. Parker, Ph.D.

---

- Professor, Civil Engineering and Director, Institute for Transportation Systems at The City College of The City University of New York
- Director, Research Careers for Minority Scholars at The City College
- Director, New York City Alliance for Minority Participation in Science
- Director, Entrepreneurial Training and Technological Assistance Program
- B.E., Civil Engineering, The City University of New York
- M.E., Transportation Engineering, and Ph.D., Systems Engineering, Cornell University
- Professor of Civil Engineering, Howard University
- Head of Department of Civil Engineering, University of Dar Es Salaam, Tanzania
- Director of Transportation Careers Pipeline Initiative Program, Region II University Transportation Center
- Active with International Road Federation, World Conference on Transport Research and the Transportation Research Board
- Co-author of textbook *Essentials of Highway Engineering* (McMillan, 1988)



# Rosa Parks (1913–2005)

---

- Irene Morgan, in 1946, and Sarah Louise Keys, in 1955, won rulings before the U.S. Supreme Court and the Interstate Commerce Commission respectively in the area of interstate bus travel
- In March 1955, 15-year-old Claudette Colvin refused to move from her seat on the Montgomery, Alabama bus system
- On December 1, 1955, also in Montgomery, Rosa Parks refused to obey bus driver James Blake's order that she give up her seat to make room for a white passenger
- Parks' action sparked the Montgomery Bus Boycott
- Parks became an icon of resistance and an important symbol of the modern Civil Rights Movement

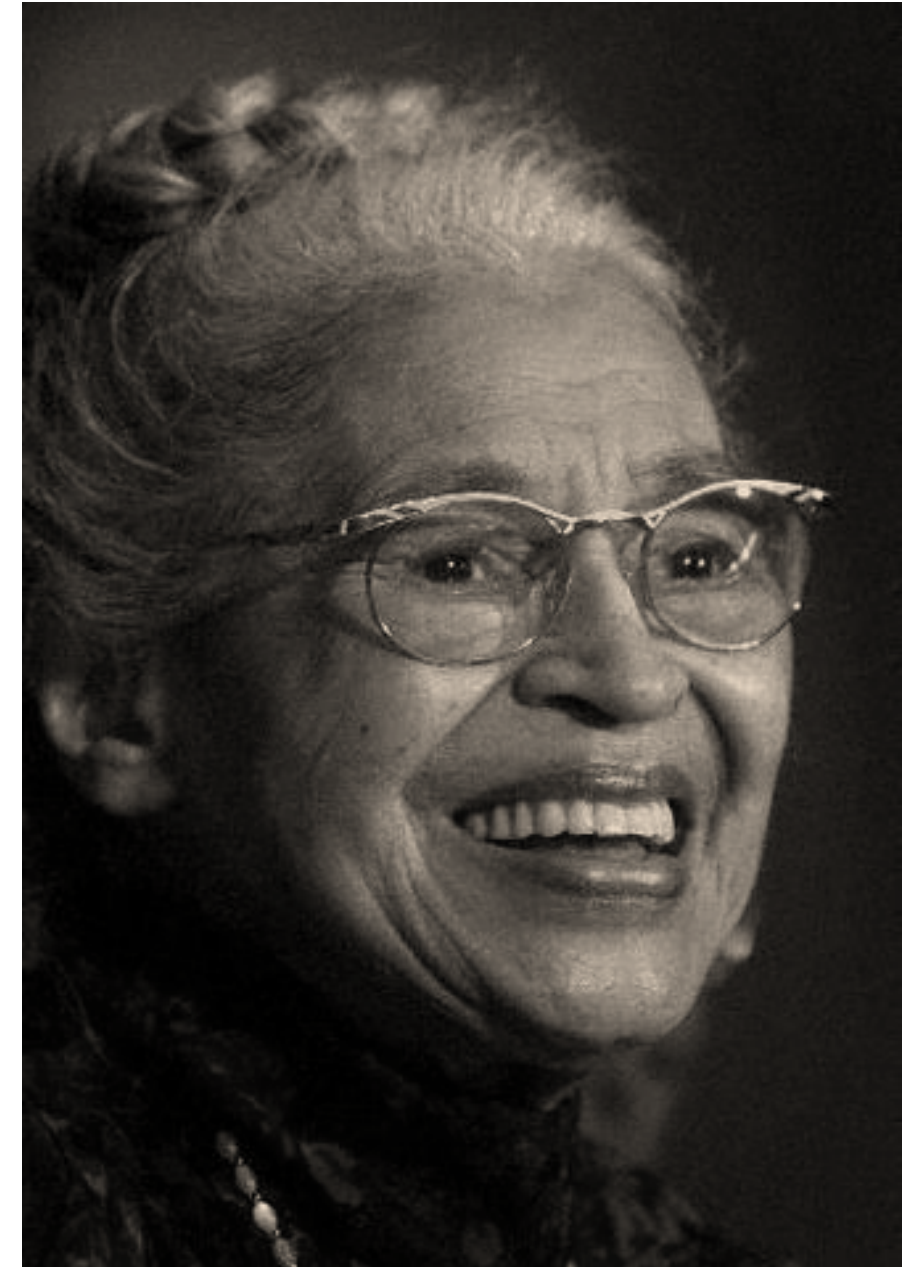

# Charles Richard Patterson

- Blacksmith who escaped from slavery in Virginia by running away to freedom
- Took over a blacksmith business in Ohio and founded the Charles R. Patterson Carriage Company
- Built horse-drawn vehicles in the 1860s.
- When Patterson died, his son Frederick Douglass Patterson took over and produced the new “horseless carriage”
- Patterson family manufactured their first Patterson-Greenfield car in 1915
- Ceased production of cars and concentrated efforts on such products as buses, hearses, moving vans, and trucks for hauling ice, milk and baked goods.
- Patterson family manufactured motorized vehicles well into the late 1930s



# William H. Phelps

Patented an apparatus for washing vehicles 1897

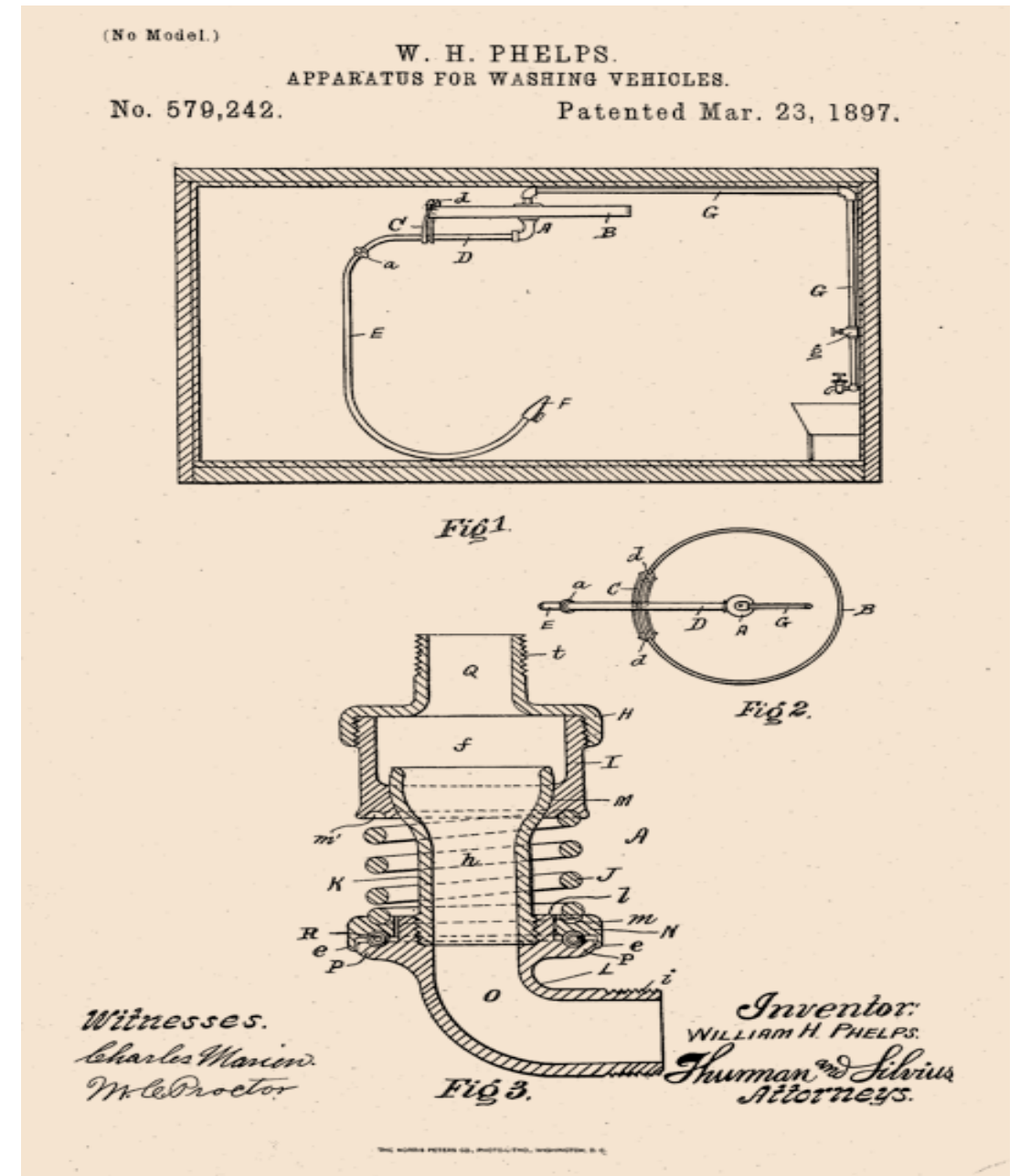



# Arcola Philpott

---

Hired as first African-American motorman at Los Angeles Railways 1944



# Cecil Reed (1912–)

- Born in Collinsville, Illinois
- Owner of the Sepia Motel in Cedar Rapids, Iowa 1953
- One of the first motels owned and operated by a black American
- Led to growing acceptance of African American lodgers in hotels across the country
- First African-American and the only black Republican elected to the Iowa House of Representatives.
- Developed curriculum for “History of Black America” course in Iowa public schools
- Chair, Iowa division of the United Nations Human Rights Committee
- published autobiography, Fly in the Buttermilk, 1993
- Received Dr. Martin Luther King Jr. Award from the local branch of the NAACP, 2002

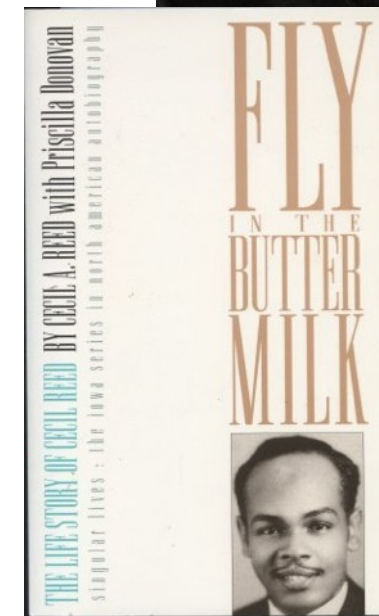
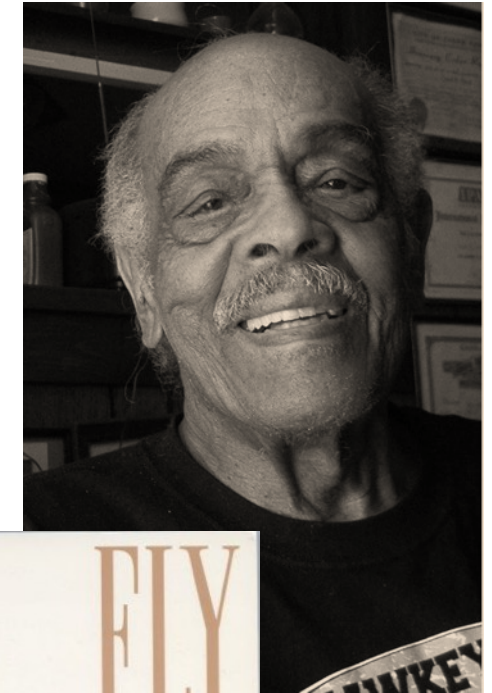

# Willy T. Ribbs

---

- First African American to qualify and compete in the Indianapolis 500, 1991
- Winner of the Formula Ford Dunlop Championship in Europe
- Recipient of two "Driver of the Year" titles
- First African American to compete in NASCAR's Winston Cup series
- First African American to compete in CART/Indy Car Championship
- First and only African American to test for Formula 1 Grand Prix team in Estroil, Portugal

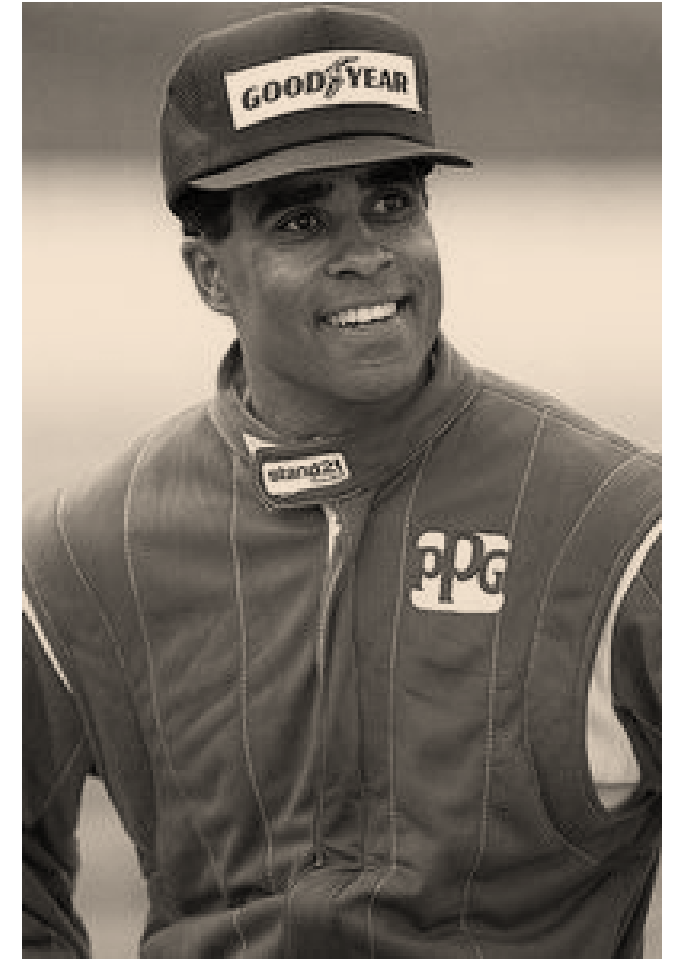

# Elbert R. Robinson

- Creatively used electricity in overhead wires to propel passenger-carrying vehicles
- Patented Electric Railway Trolley 1893

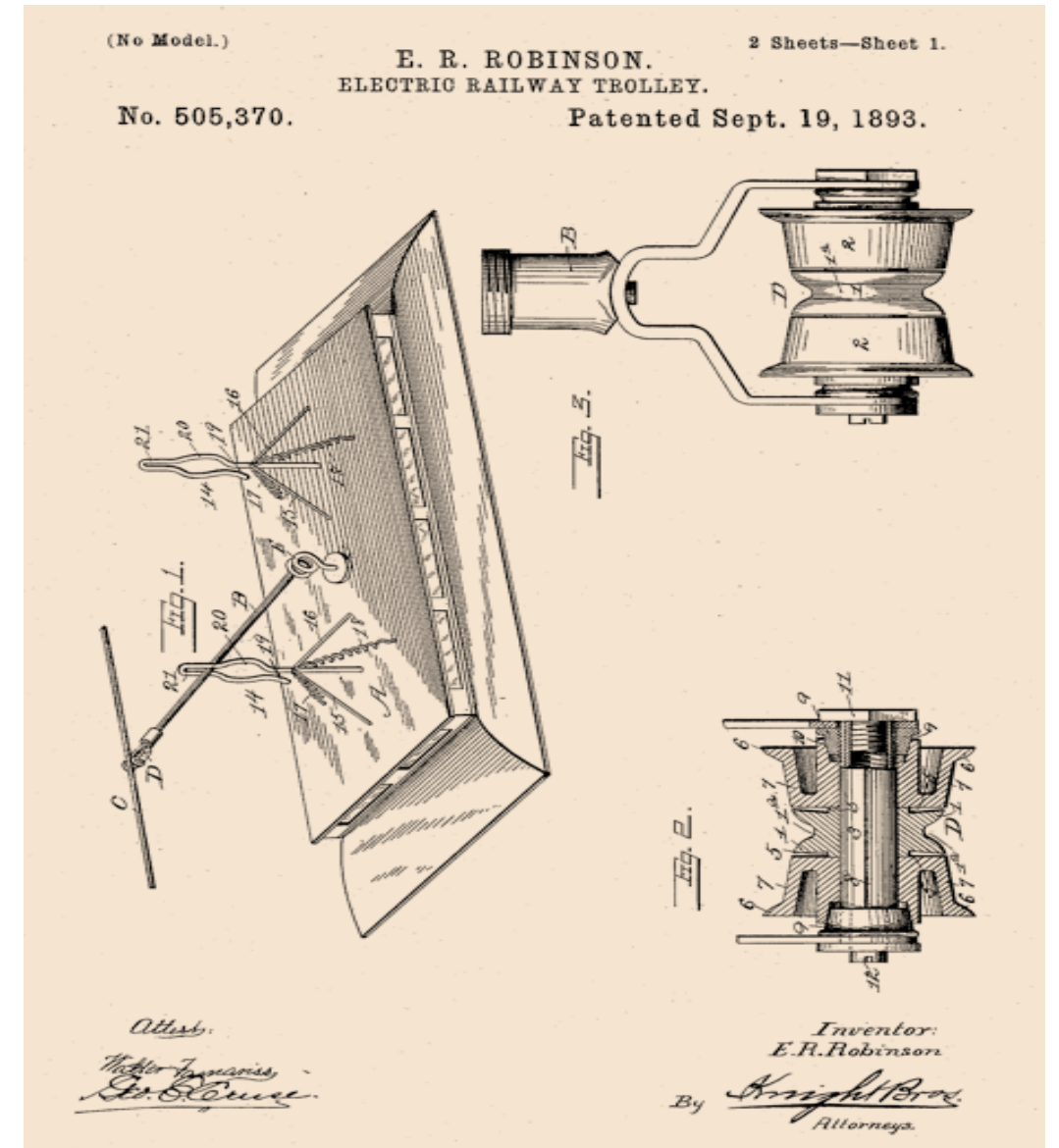

# Gerald M. Ross

---

- Chief Engineer at Georgia Department of Transportation, responsible for the Divisions of Planning, Data & Intermodal Development; Pre-Construction; Construction and Operations
- Born Atlanta, Georgia
- B.S. Civil Engineering, Tennessee Tech University
- Registered Professional Engineer in Georgia
- AASHTO Sub-Committee on Design and AASHTO Standing Committee on Planning



# Ralph W. Sanderson

Patented hydraulic shock absorber, 1968 (3,362,742)

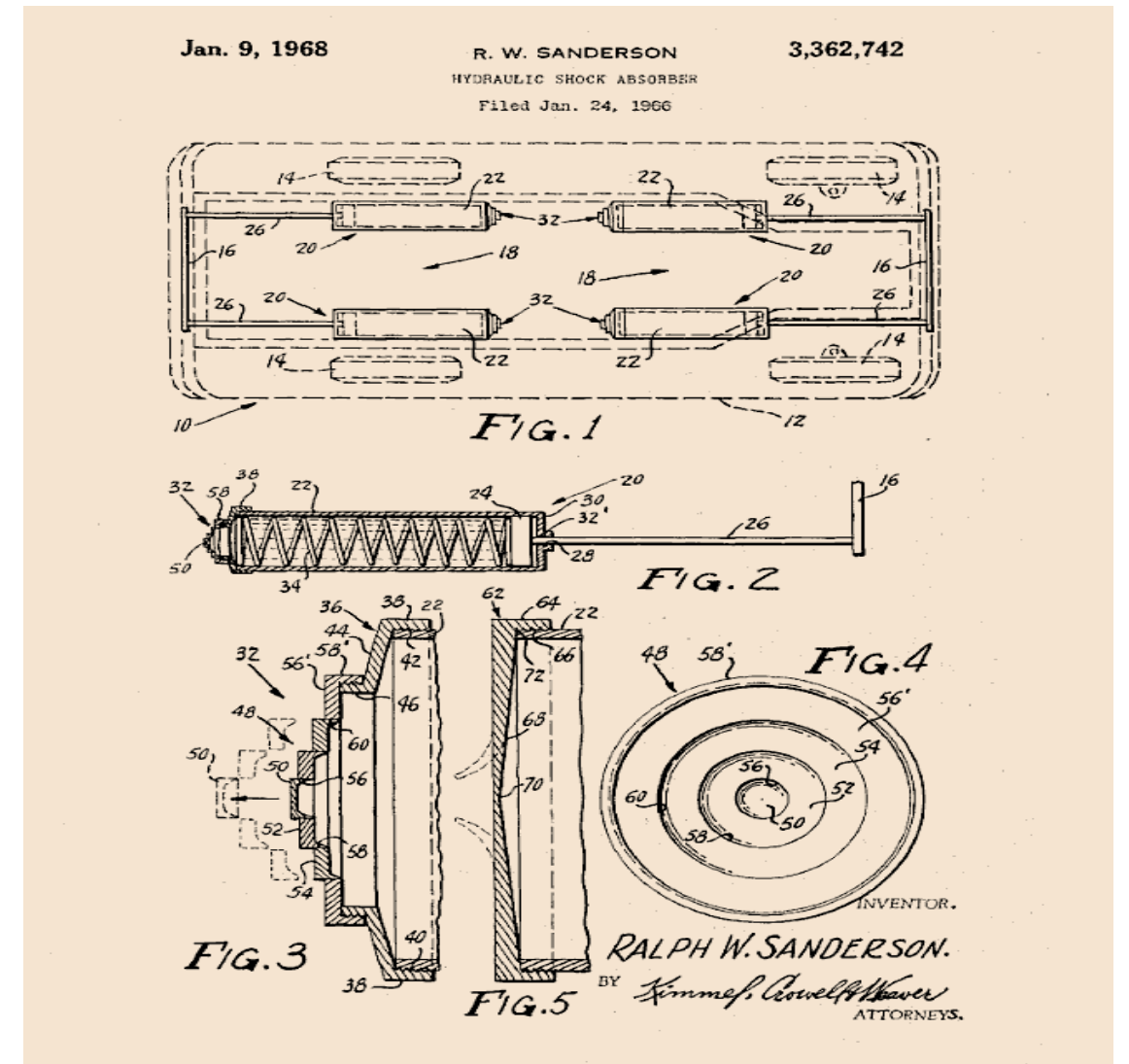

# Wendell Oliver Scott (1921–1990)

---

- Born Danville, Virginia
- Started racing at the Danville Fairgrounds Speedway.
- Won 120 races in lower divisions and in 1959, won state championships in his classes
- In 1961 fielded a car on NASCAR's top-level Grand National circuit (later renamed Winston Cup)
- Raced in nearly 500 races in NASCAR's top division from 1961–early 1970s, finished in the top ten 147 times
- Won his only major race on December 1, 1963, a 100-mile event on a half-mile track in Jacksonville, Florida, but was denied the opportunity to celebrate in Victory Circle
- Injured in race at Talladega, Alabama, 1973
- Raced only a few times afterward



# Rodney Earl Slater (1955–)

---

- Born Marianna, Arkansas
- Graduated from Eastern Michigan University, and received J.D., University of Arkansas
- Arkansas Assistant Attorney General
- Director of Governmental Affairs, Arkansas State University
- Special Assistant to the Arkansas Governor for Community and Minority Affairs
- Executive Assistant to the Arkansas Governor for Economic and Community Programs
- First African American member and chair of Arkansas Highway Commission
- First African American Administrator of the Federal Highway Administration
- Second African American Secretary of Transportation
- Negotiated 40 Open skies agreements with other countries
- Launched and actively promoted the Garrett A. Morgan Technology and Transportation Futures Program, aimed at attracting a million youth into transportation careers, and mentoring and tutoring them to make sure they have needed skills





# Richard Spikes

---

- From San Francisco, California
- Patented or developed the following inventions:
  - Railroad semaphore (1906)
  - Automatic car washer (1913)
  - Automobile directional signals (1913), manufactured by Pierce Arrow
  - continuous contact trolley pole (1919), used on on the famous San Francisco Key System
  - Improved automatic gear shift (1932), licensed the patent for \$100,000
  - Transmission and shifting thereof (1933)
  - Automatic safety brake (1962)
- Died 1962



# Edward T. Welburn

---

- Vice President of Global Design for General Motors
- Highest-ranking position as an African-American in the automotive industry
- Has overseen the development of GM products such as the 2010 Buick LaCrosse, 2010 Chevrolet Camaro, Chevrolet Malibu, Cadillac CTS, and Buick Enclave
- Has overseen concepts overseen such as the Cadillac Converj, Cadillac CTS Coupe, Chevrolet Camaro Coupe, Chevrolet Camaro Convertible, and the Buick Invicta Concept

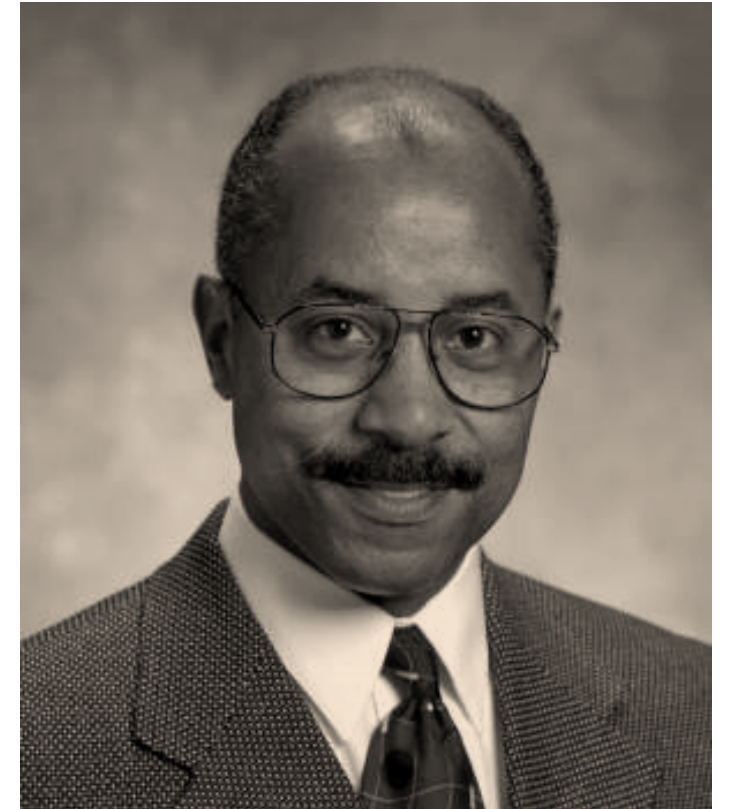

# Joseph B. Williams

---

- Born Annapolis, MD
- Graduated from Hampton Institute 1942
- The first African-American Graduate of U.S. Merchant Marine Academy, 1944
- Navy service during World War II and the Korean War
- Sailed as a cadet-in-training aboard the Liberty Ship *Booker T. Washington* under the leadership of Hugh Mulzac
- Bachelor of Law degree, New York University 1949, and master's in 1954
- Appointed to New York's Family Court in 1966.
- Administrator of Model Cities program
- Administrative judge of the criminal courts 1982
- New York State Supreme Court's Appellate Team 1986
- Chair of Bedford-Stuyvesant Restoration Corporation
- Died 1992



# Paul E. Williams

- Patented a compound experimental helicopter, Lockheed Model 186 (XH-51) 1962
- A total of 3 units were built

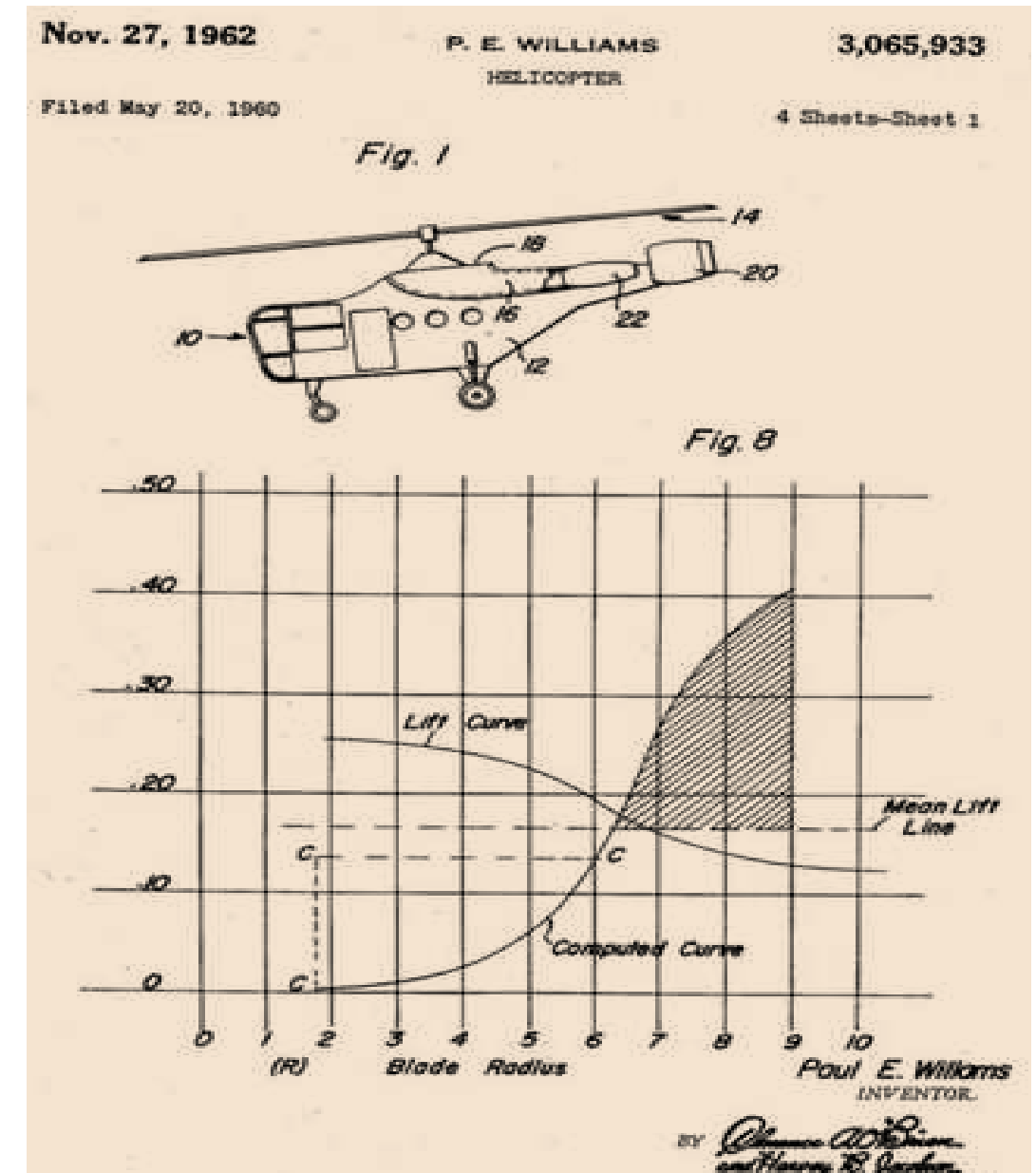

# Barbara J. Wilson

---

- Graduated from Prairie View A & M University in Texas
- Worked in accounting at General Motors
- Worked with her husband, Pontiac dealer in Detroit, 1970
- First African-American woman automobile dealer—President and Dealer Operator of Honda dealership in Ferndale, MI, 1979–1996
- Candace award as businesswoman of the year





# Anthony R. Foxx

---

- Born 1971
- U.S. Secretary of Transportation 2013-2017
- Mayor of Charlotte, North Carolina 2009-2013
- BA Davidson College
- JD New York University

