

SUMMER

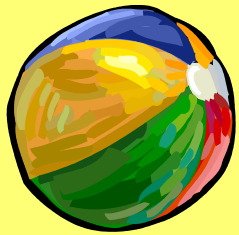

FUN



Including Pete the Cat
worksheets

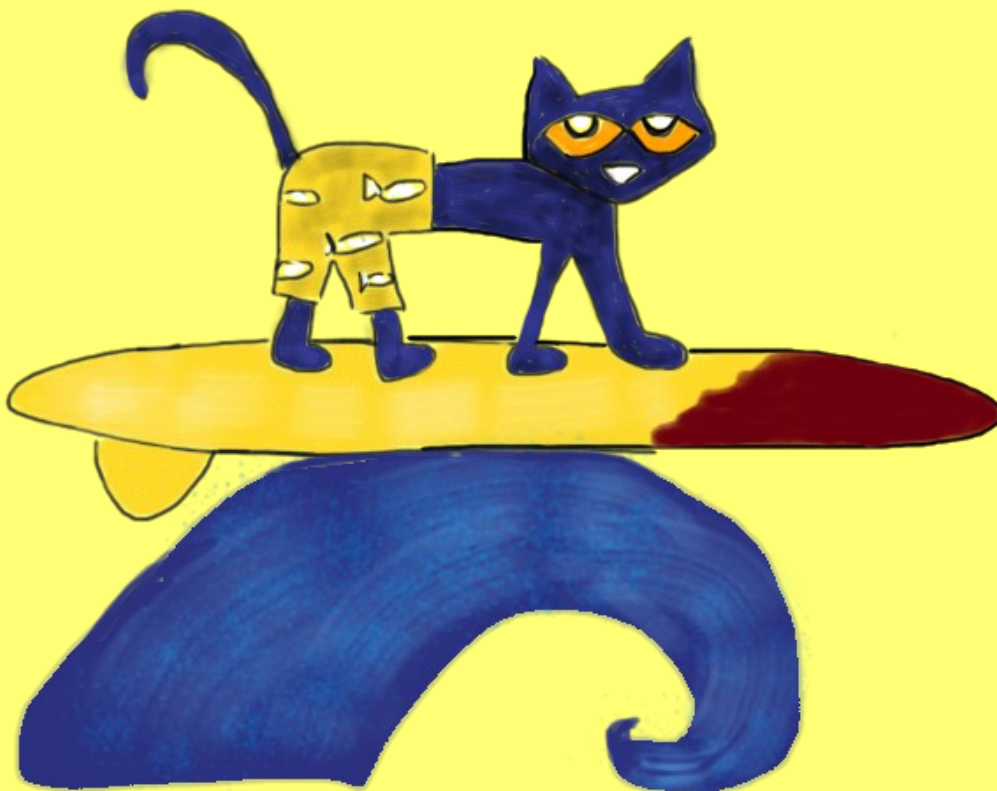

**Worksheets to review
for your Kindergarten
students or prepare
your Pre-K students
for Kindergarten.**



Name _____

Draw a line to match upper/lower case letters.

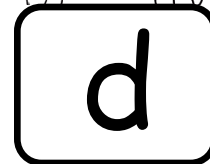
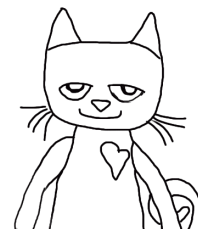
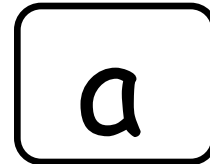
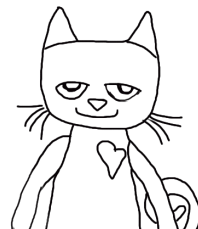
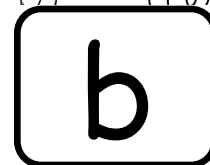
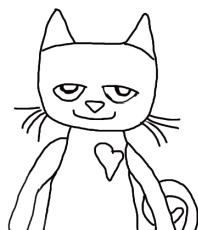
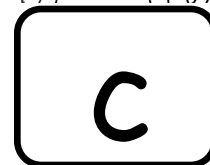
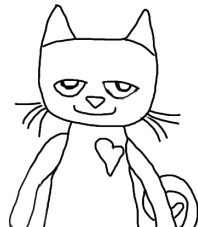
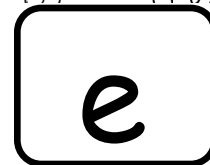
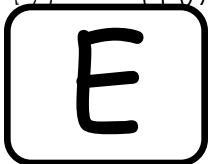
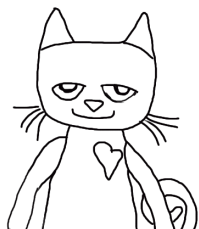
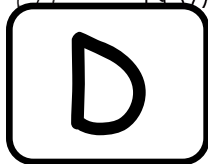
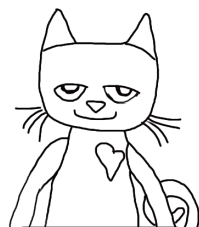
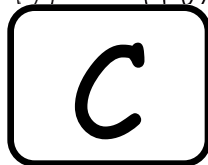
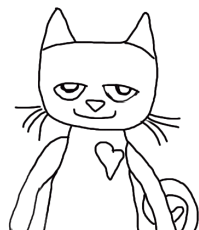
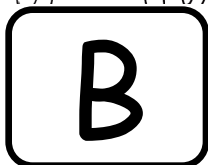
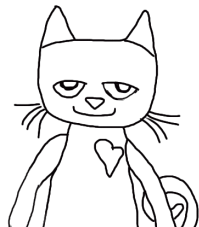
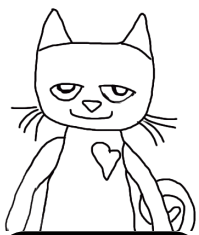

Name _____

Draw a line to match upper/lower case letters.

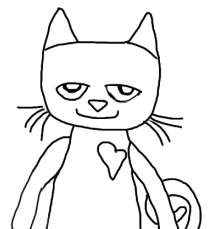
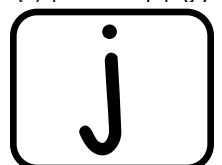
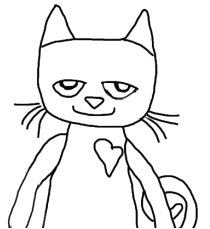
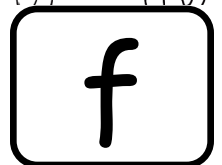
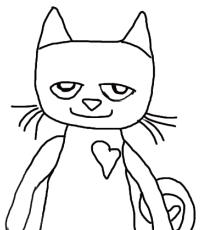
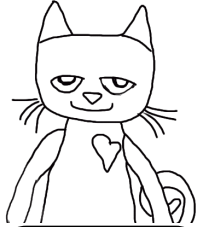
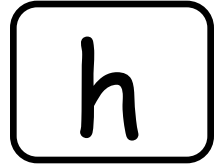
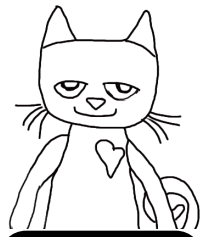
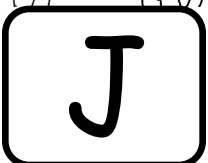
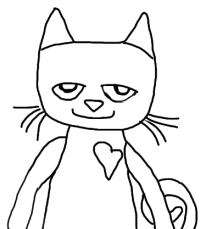
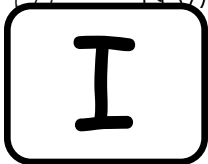
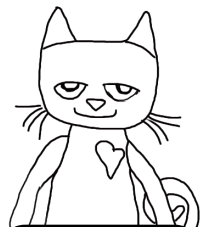
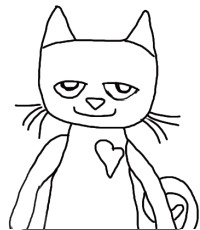
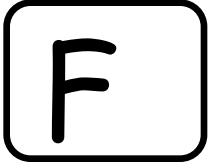
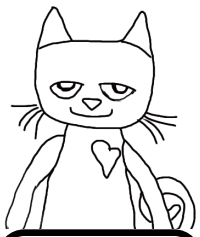

Name _____

Draw a line to match upper/lower case letters.

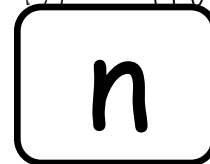
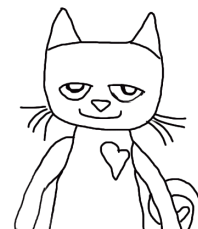
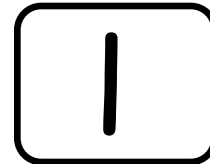
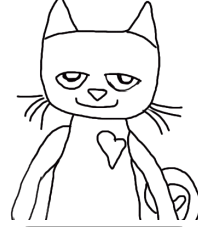
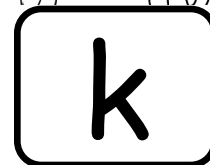
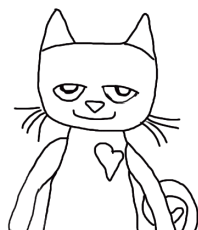
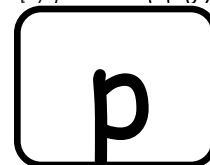
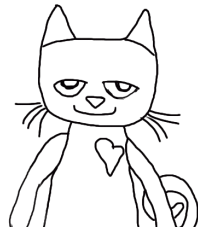
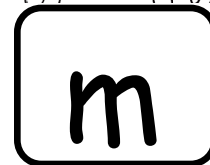
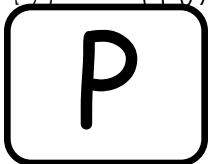
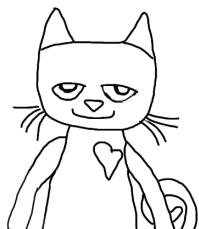
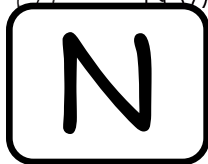
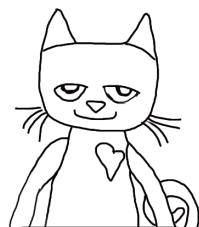
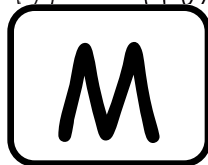
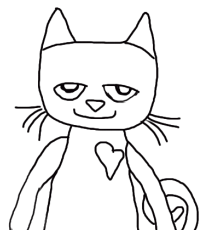
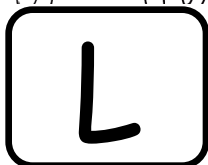
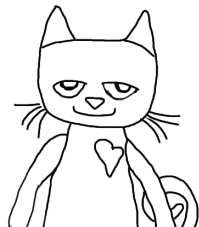
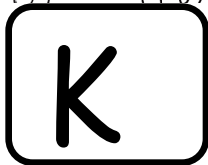
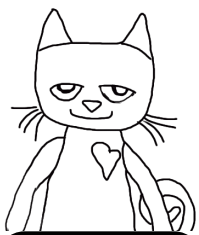

Name _____

Draw a line to match upper/lower case letters.

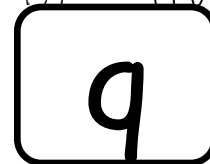
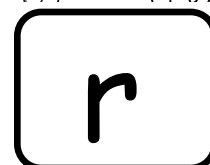
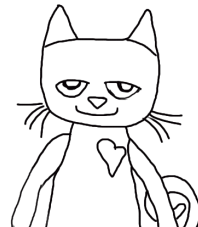
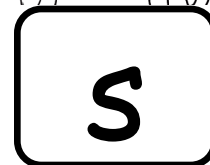
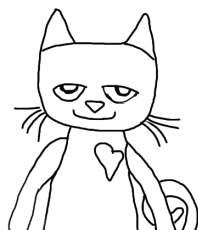
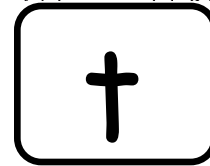
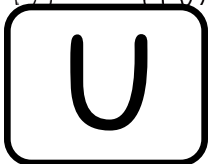
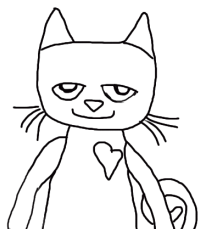
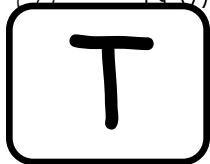
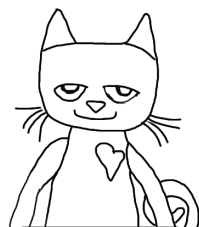
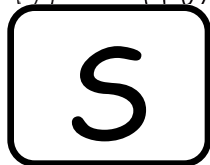
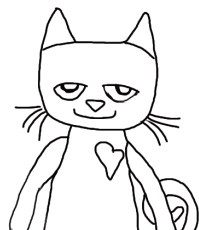
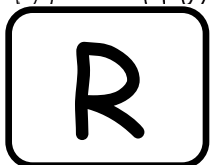
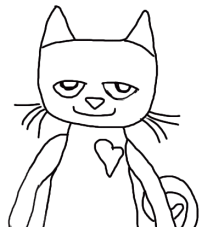
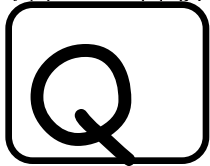
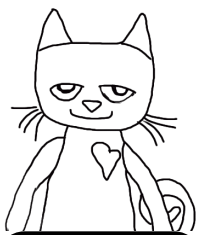

Name _____

Draw a line to match upper/lower case letters.

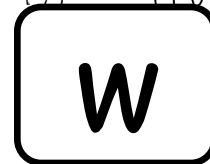
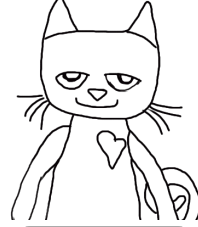
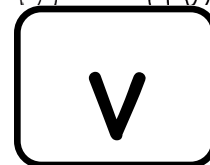
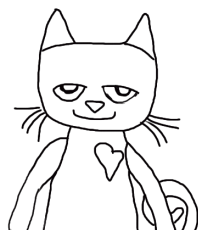
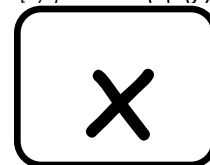
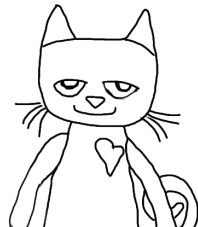
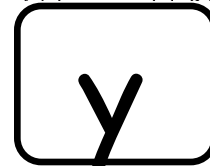
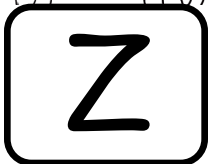
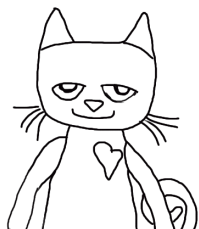
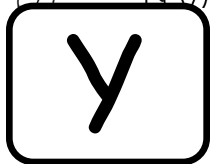
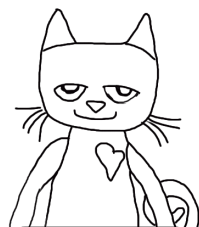
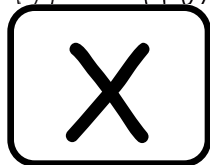
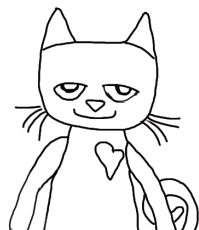
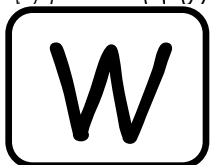
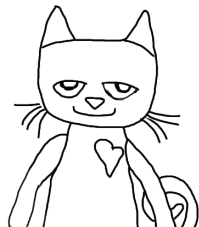
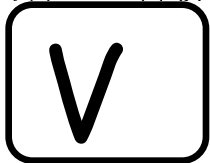
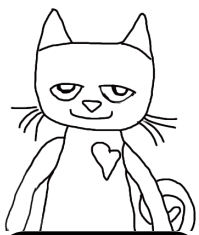

Writing Word Families

Name: _____

Look at the word family written on Pete's surfboard. Write 5 words that belong in each group.

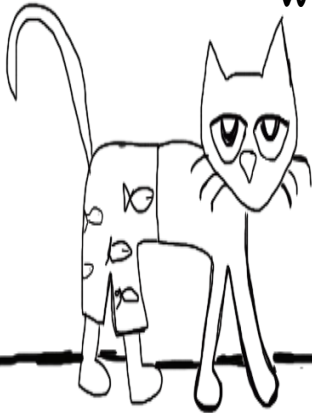

-at

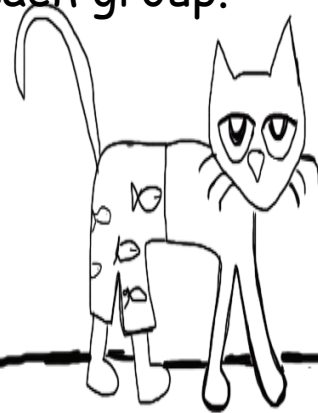

-ig

Writing Word Families

Name: _____

Look at the word family written on Pete's surfboard. Write 5 words that belong in each group.

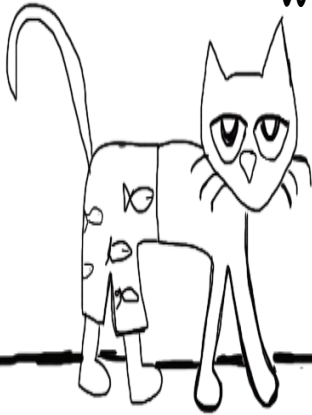

-un

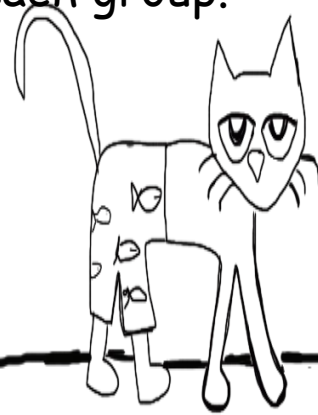

-ip

Writing Word Families

Name: _____

Look at the word family written on Pete's surfboard. Write 5 words that belong in each group.

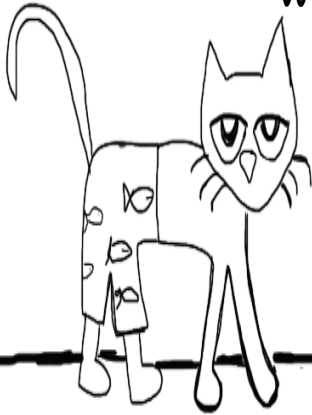

-am



-up

Writing Word Families

Name: _____

Look at the word family written on Pete's surfboard. Write 5 words that belong in each group.

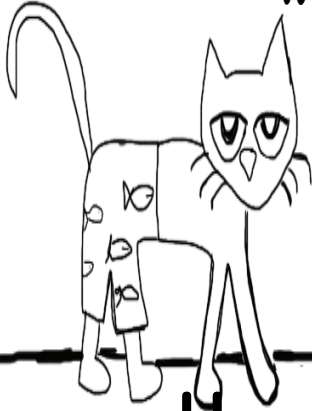

-ell

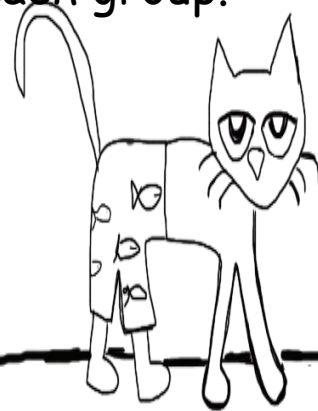

-ing

My Picture!

My Story:

Handwriting practice lines consisting of solid top and bottom lines with a dashed midline, repeated five times.

This is a picture of me!

I can write my FIRST name four times:

Handwriting practice lines consisting of four sets of three horizontal lines (top solid, middle dashed, bottom solid).

This is a picture of my family

I can write my LAST name four times:

Four sets of handwriting practice lines, each consisting of a solid top line, a dashed middle line, and a solid bottom line.

Fill in the Missing Capital Beach Ball Letters

Name: _____

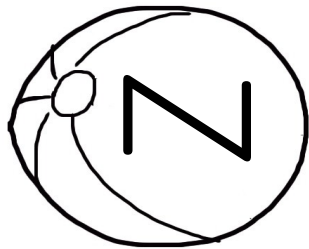
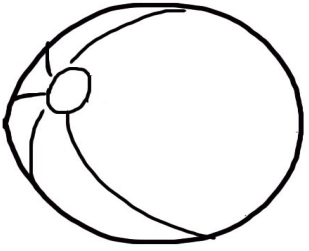
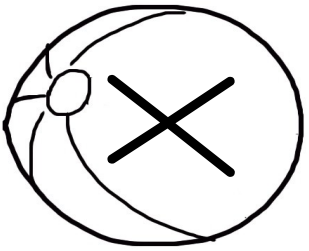
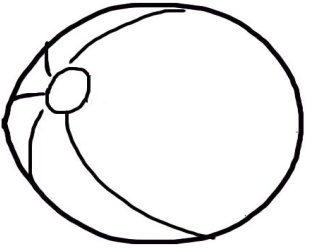
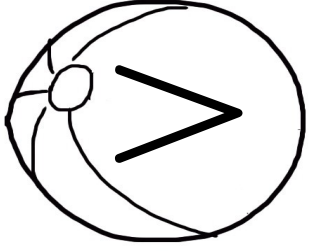
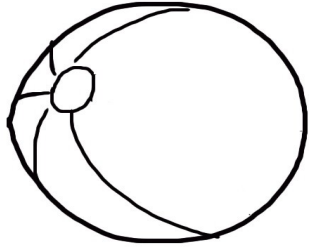
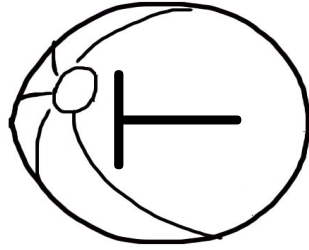
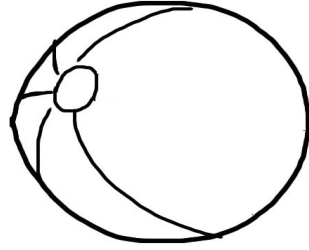
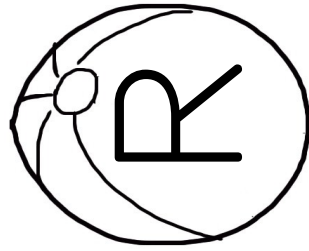
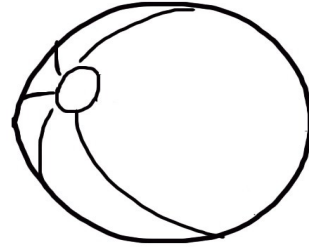
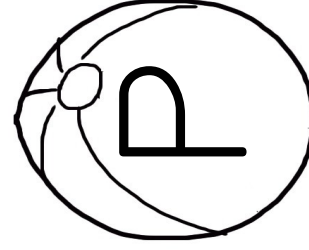
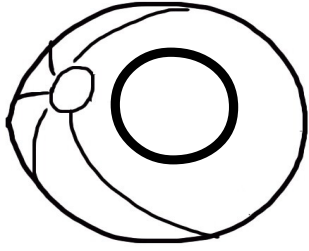
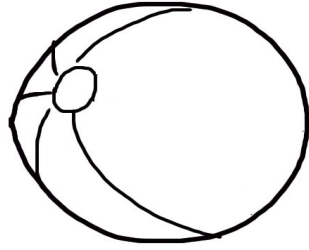
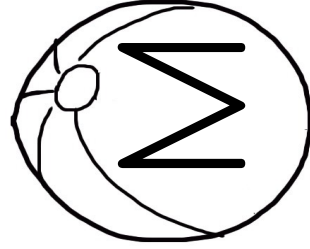
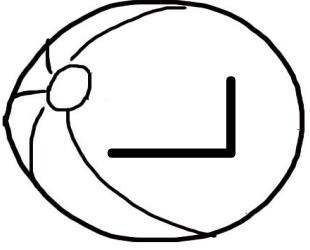
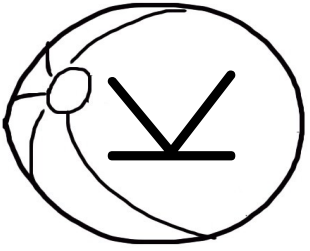
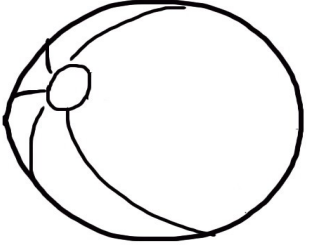
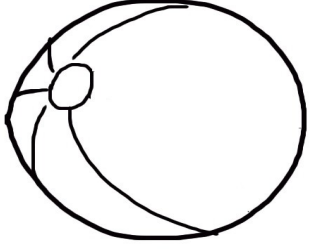
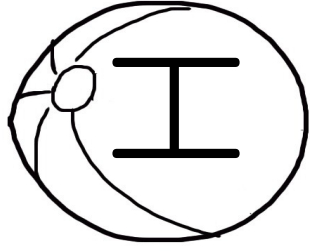
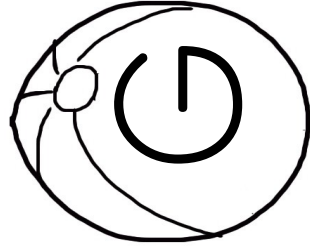
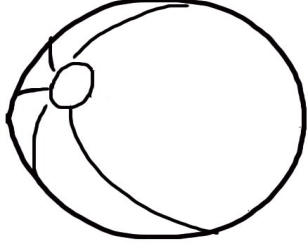
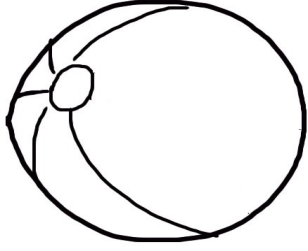
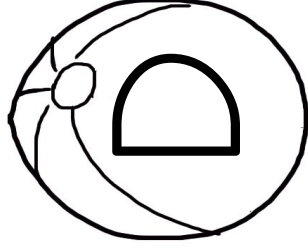
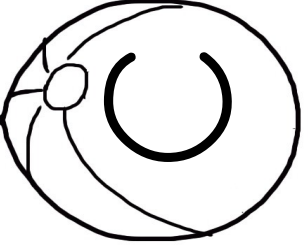
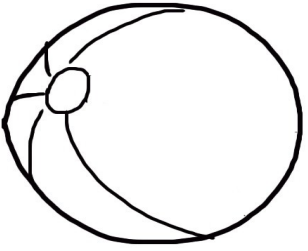
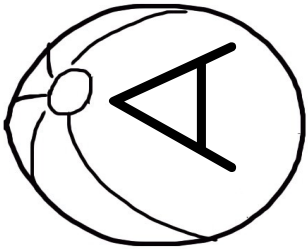

Fill in the Missing Lower Case Beach Ball Letters Name: _____

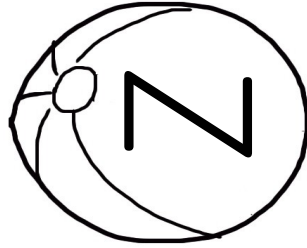
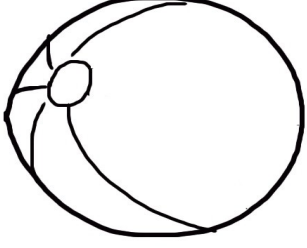
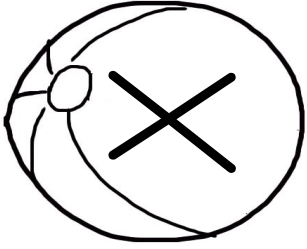
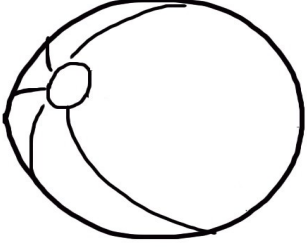
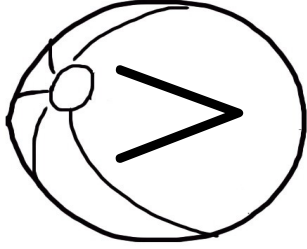
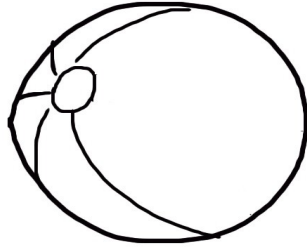
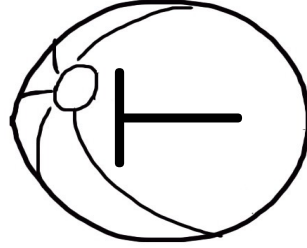
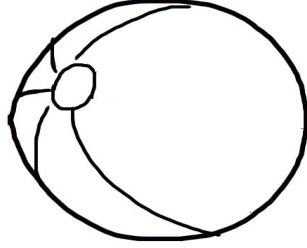
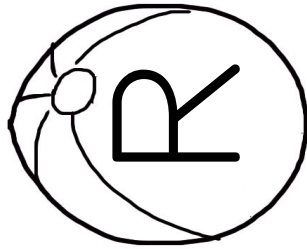
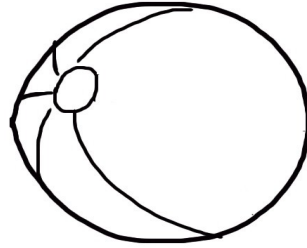
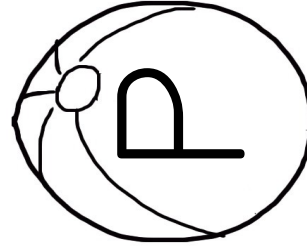
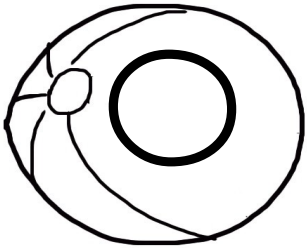
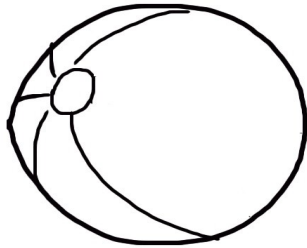
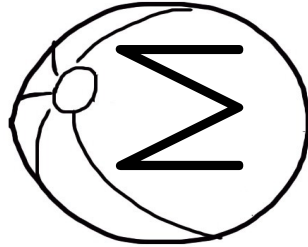
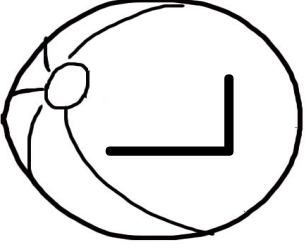
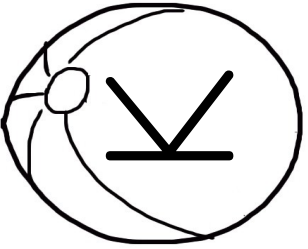
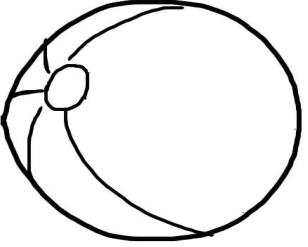
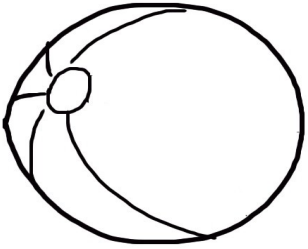
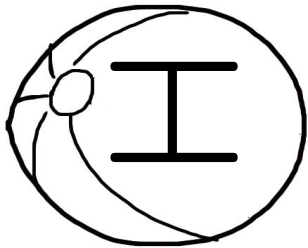
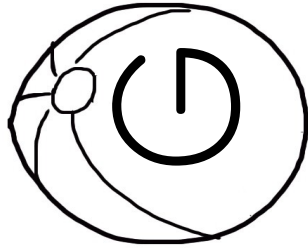
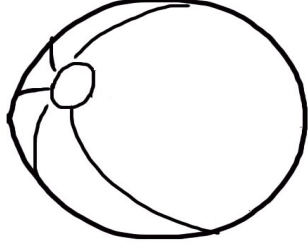
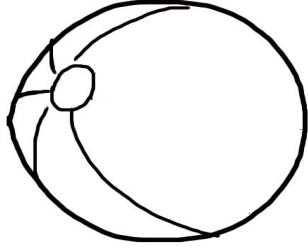
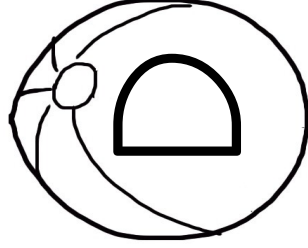
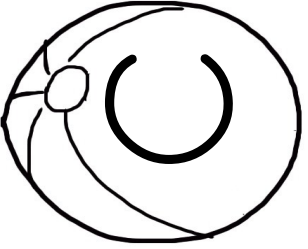
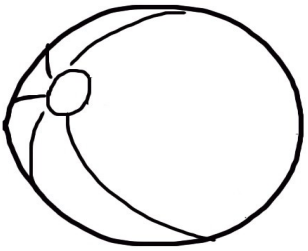
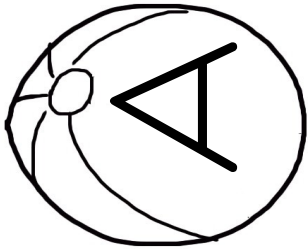

Write the UPPER CASE Letters of the Alphabet Name: _____

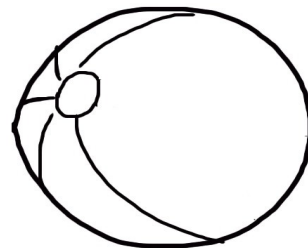
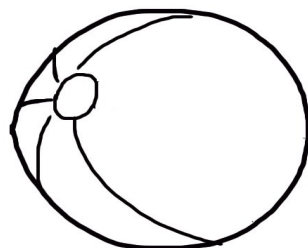
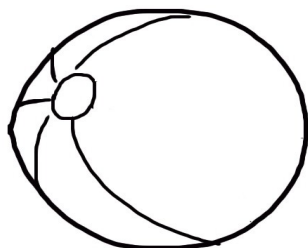
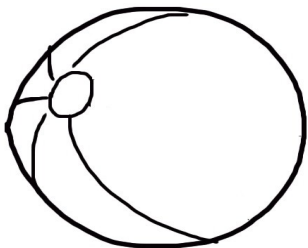
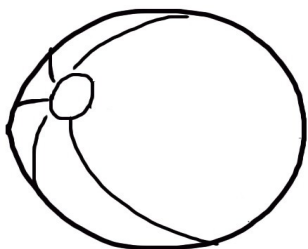
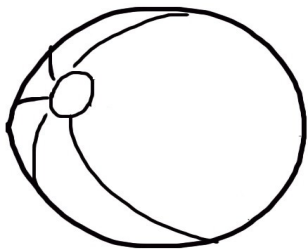
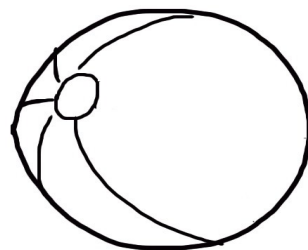
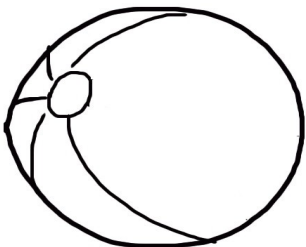
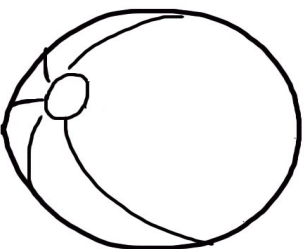
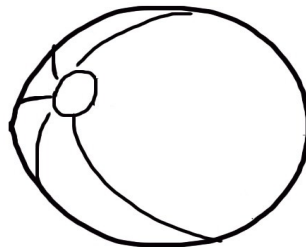
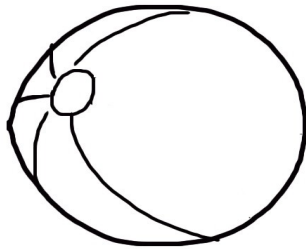
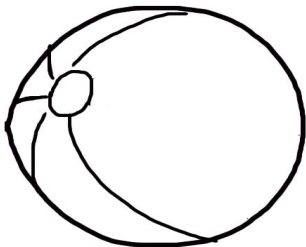
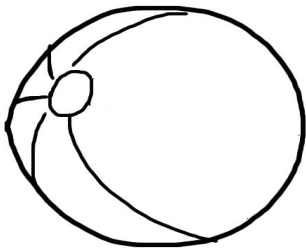
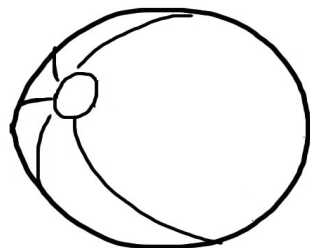
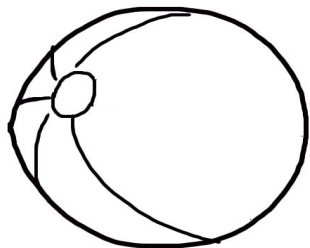
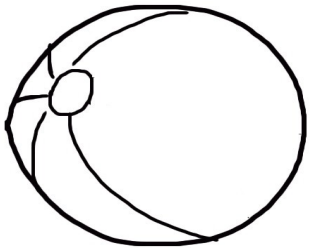
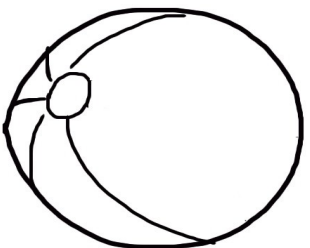
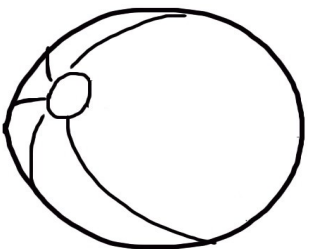
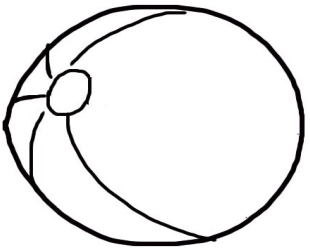
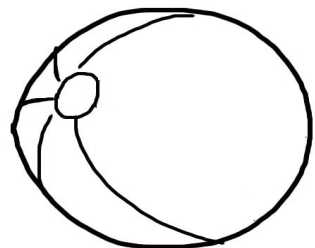
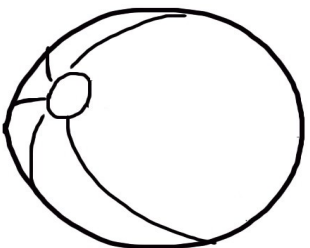
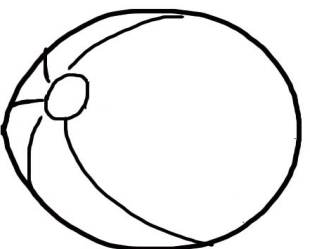
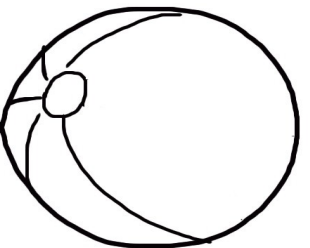
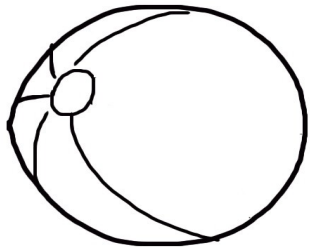
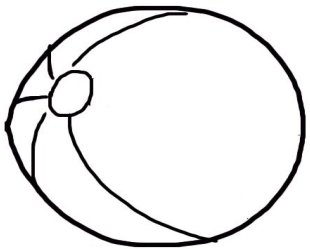
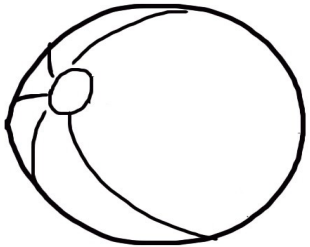

Name _____

Draw a line to match the beach ball to the right letter sounds.

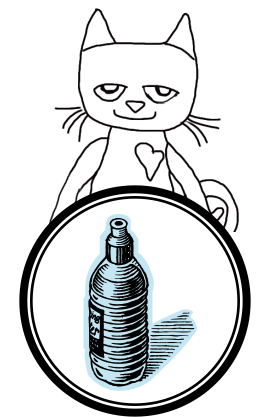
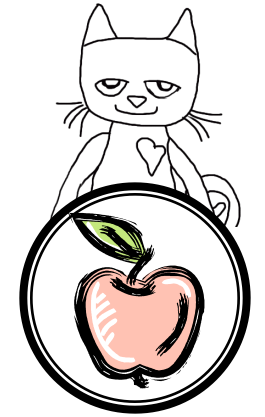
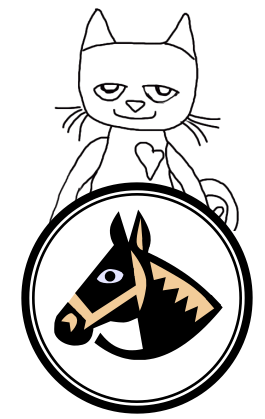
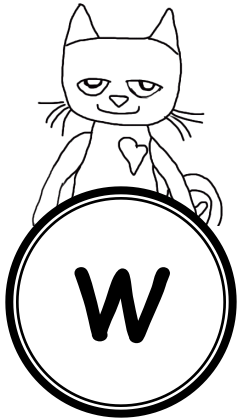
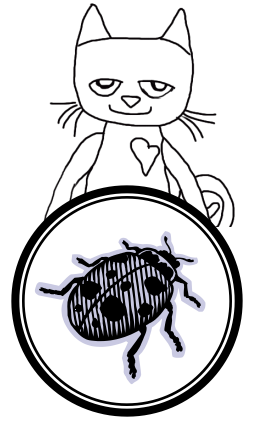
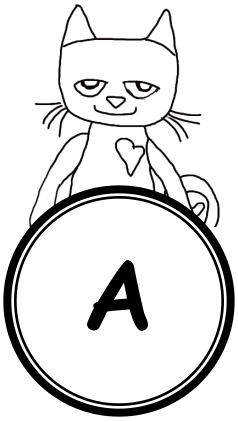

Name _____

Draw a line to match the beach ball to the right letter sounds.

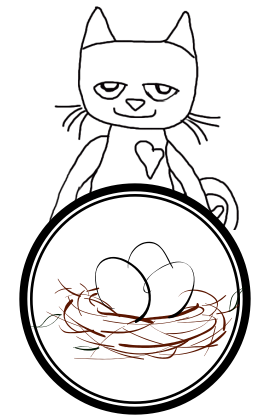
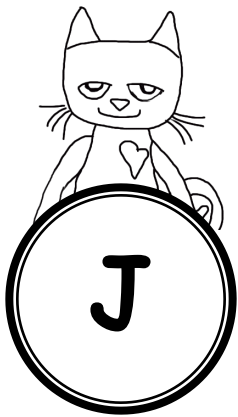
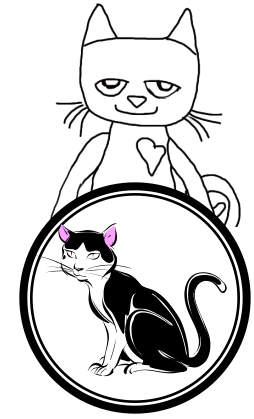
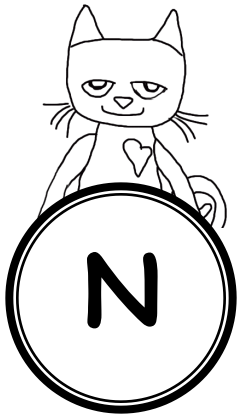
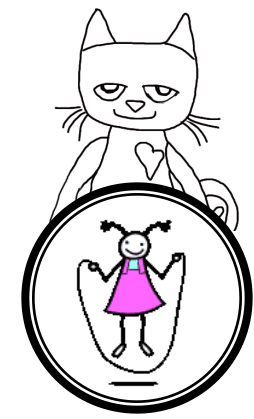
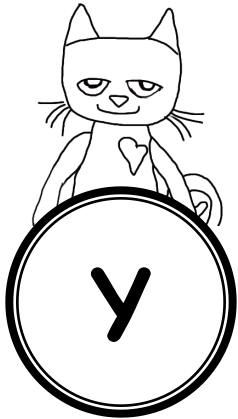
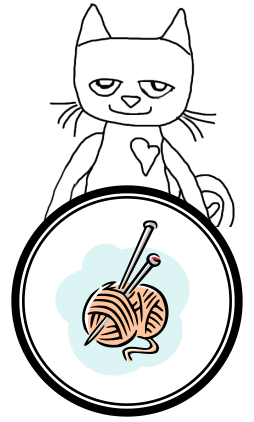
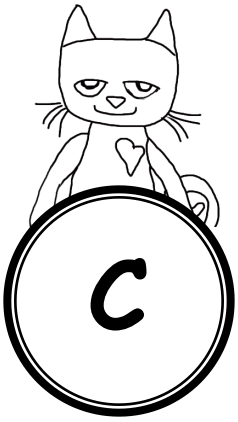

Name _____

Draw a line to match the beach ball to the right letter sounds.

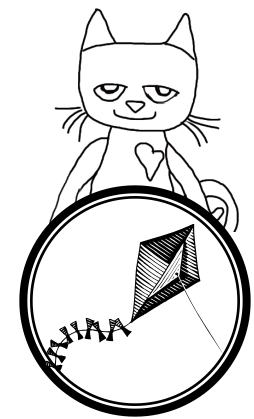
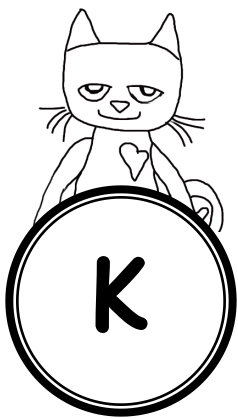
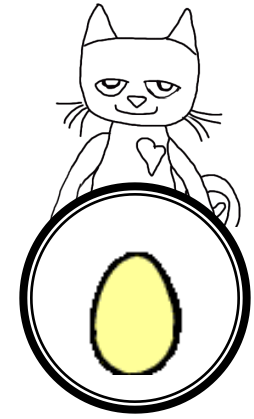
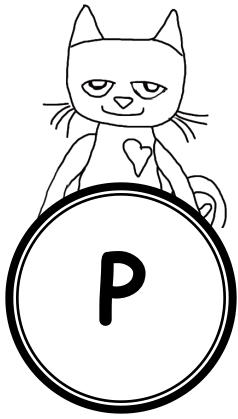
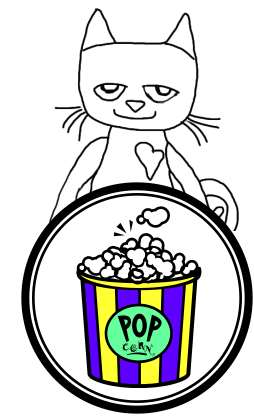
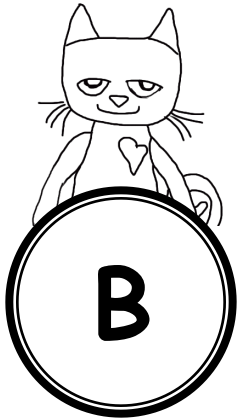
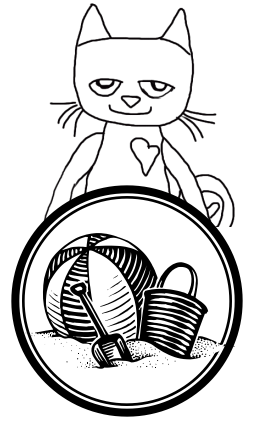
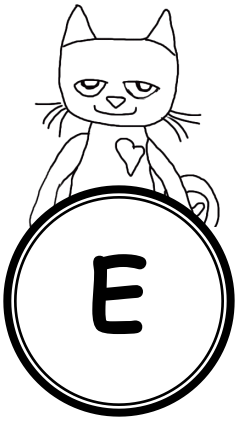

Name _____

Draw a line to match the beach ball to the right letter sounds.

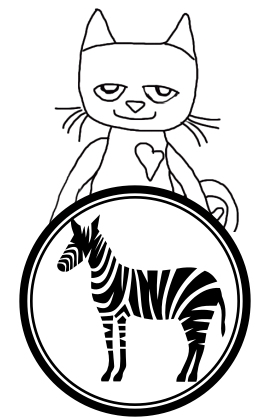
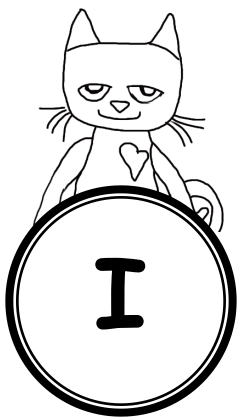
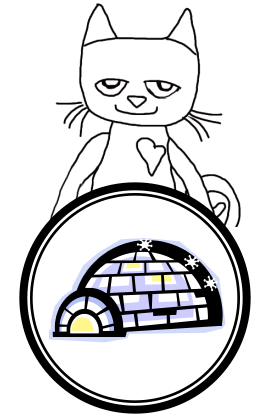
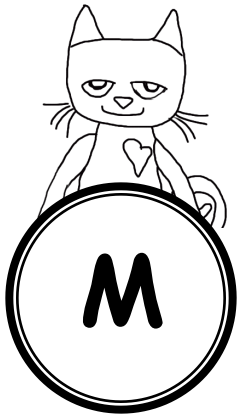
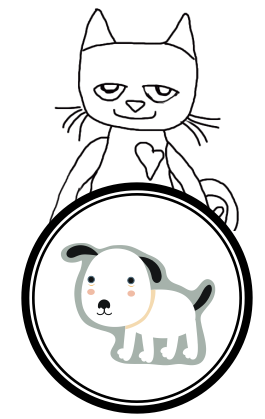
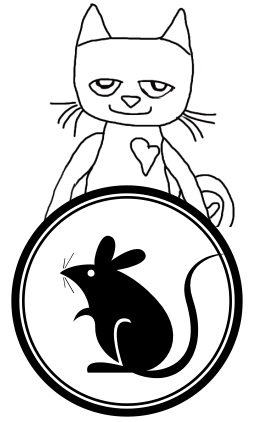
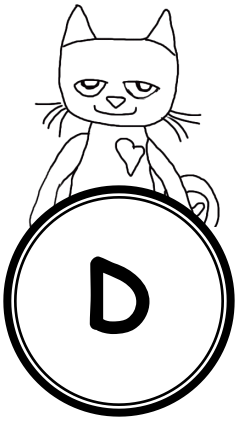

Name _____

Draw a line to match the beach ball to the right letter sounds.

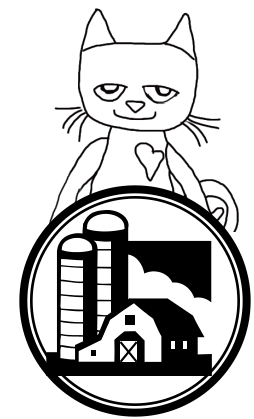
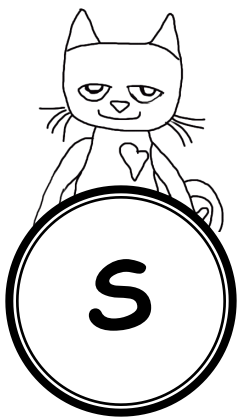
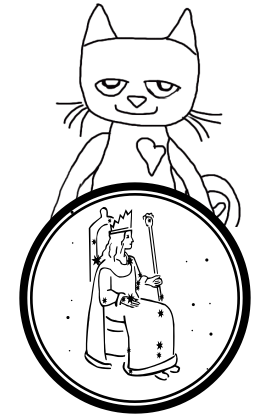
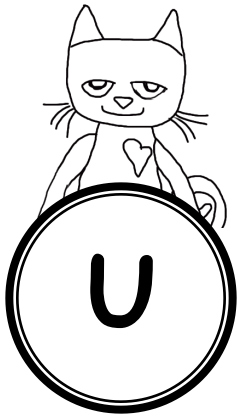
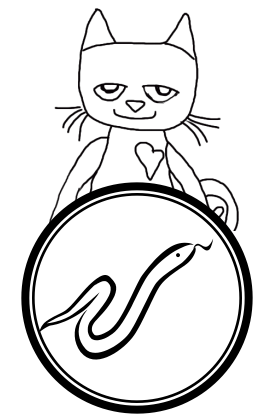
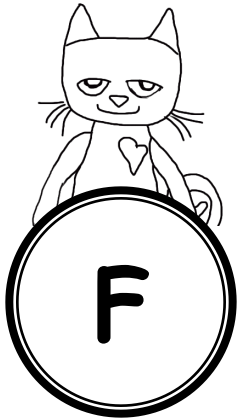
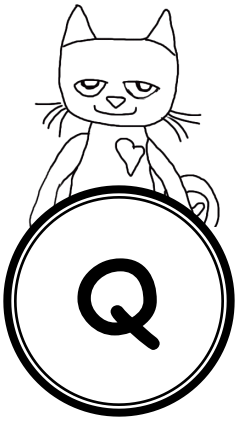

Name _____

Draw a line to match the beach ball to the right letter sounds.

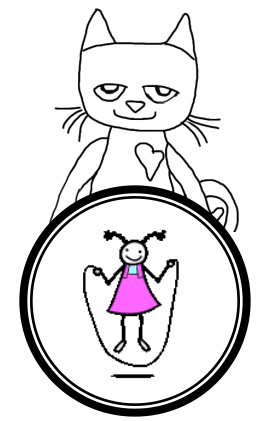
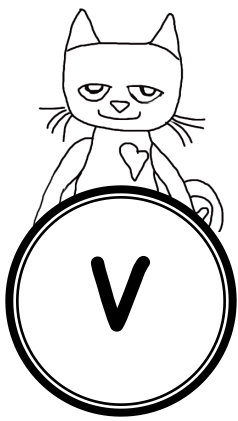
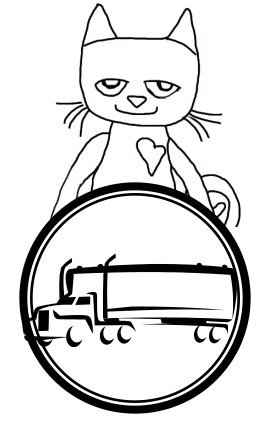
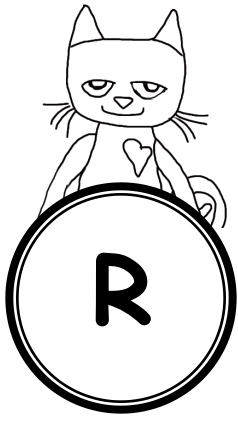
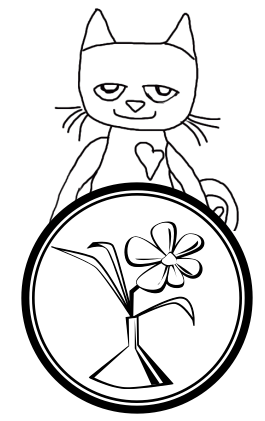
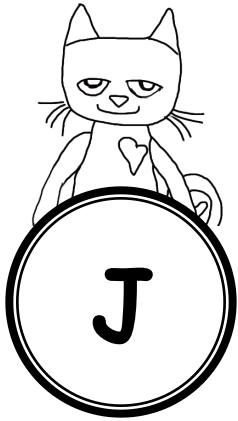
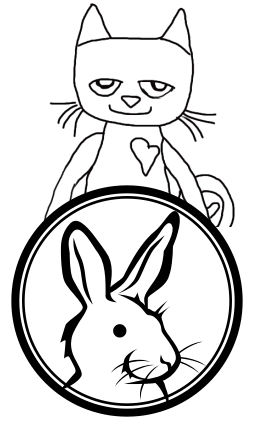
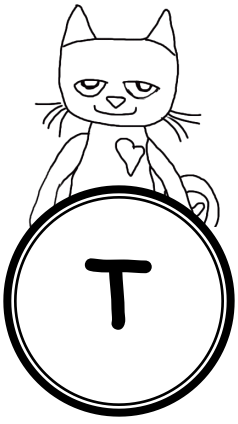





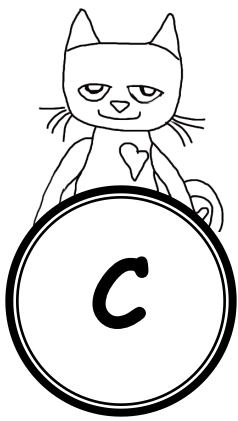
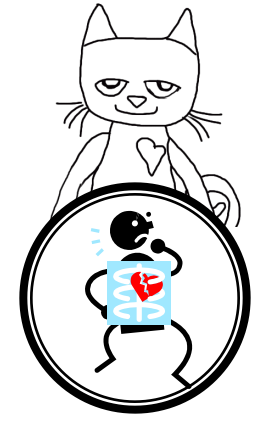
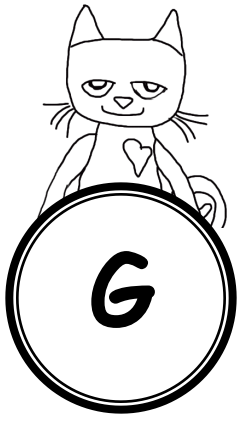
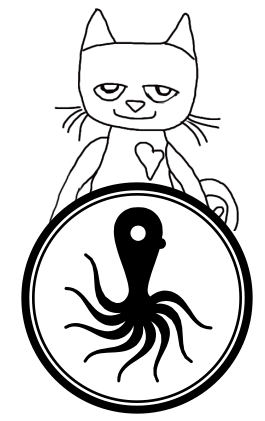
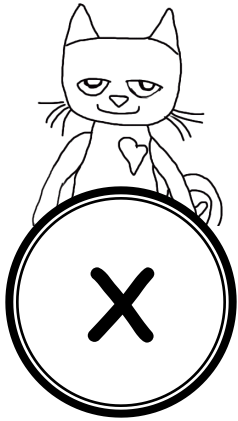
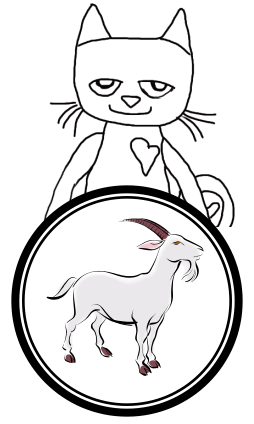
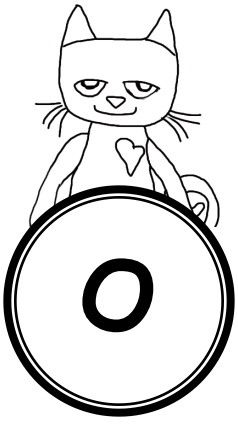

Name _____

Draw a line to match the beach ball to the right letter sounds.

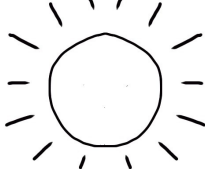

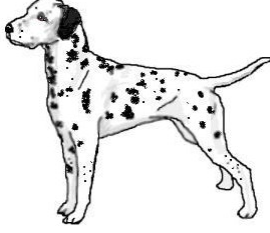
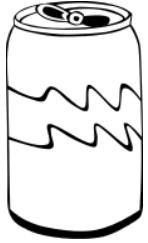
Compound Words Name: _____

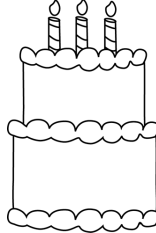
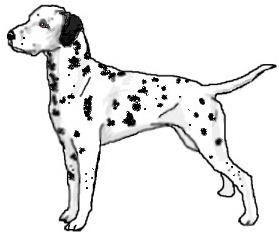
Cut apart the picture cards at the bottom and glue into the box to make the compound word.

	+		=
	+		=
	+		=
	+		=
	+		=

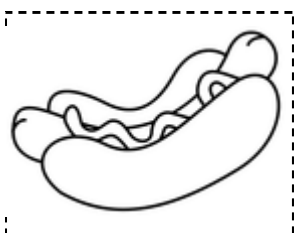
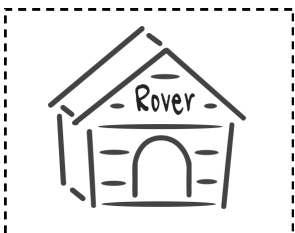
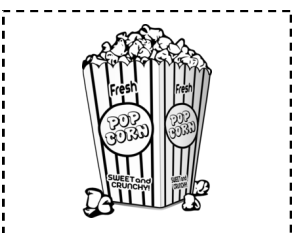

Beginning Word Sounds

Name: _____

Look at the pictures in each box. Write the beginning sound for each picture.



car



pig

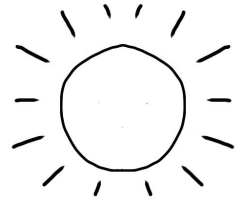

sun



net

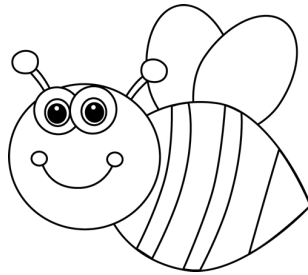

bee



hen



cat

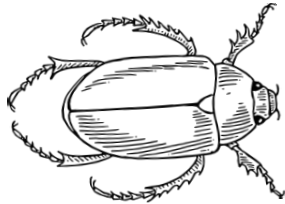

bug



dad

Does it start with E?

Name: _____

Color all of the beach balls that has a picture that starts with the letter E?

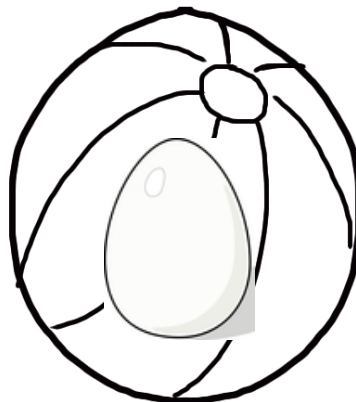
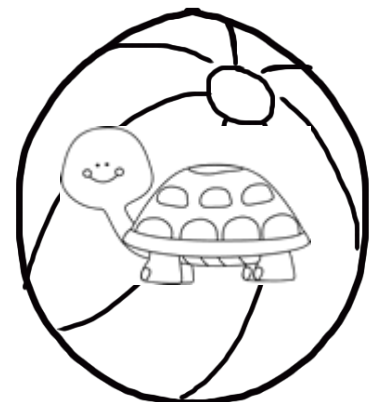
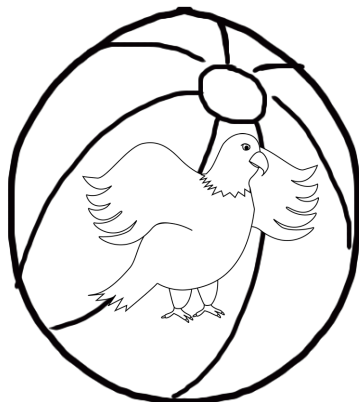
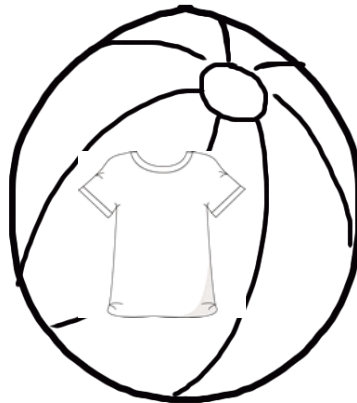
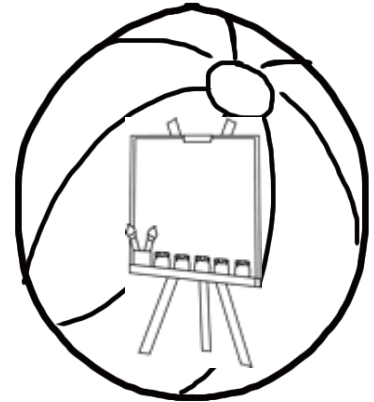
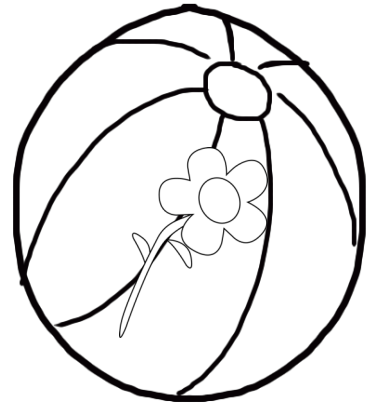
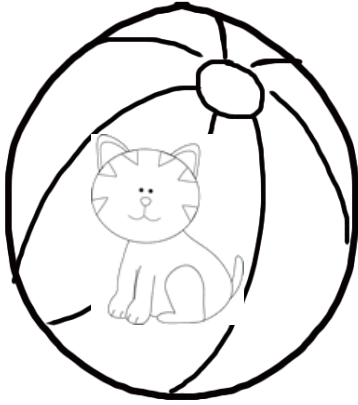

Does it start with S?

Name: _____

Color all of the beach balls that has a picture that starts with the letter S?

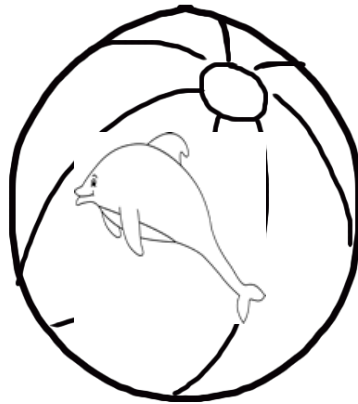
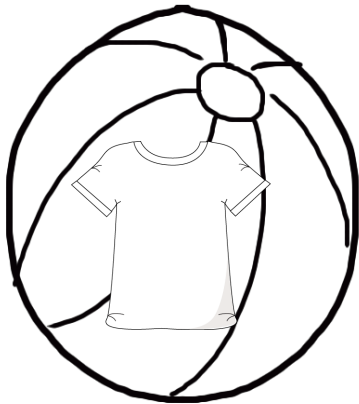
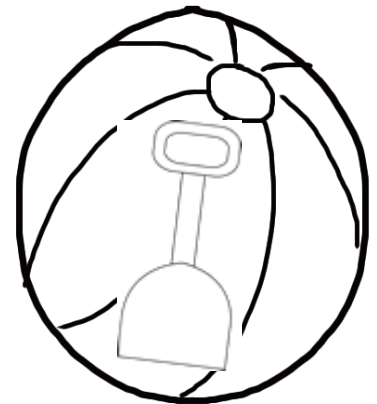
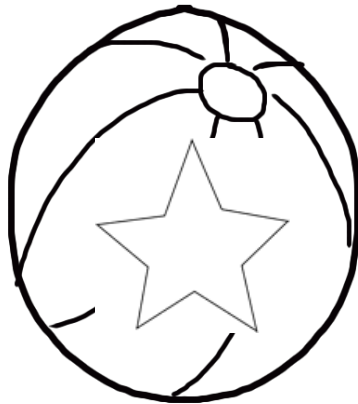
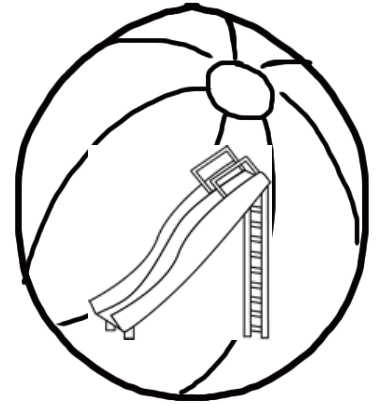
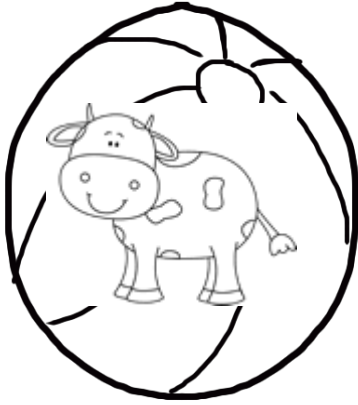

Does it start with M?

Name: _____

Color all of the beach balls that has a picture that starts with the letter M?

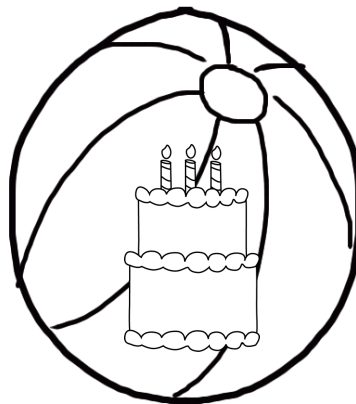
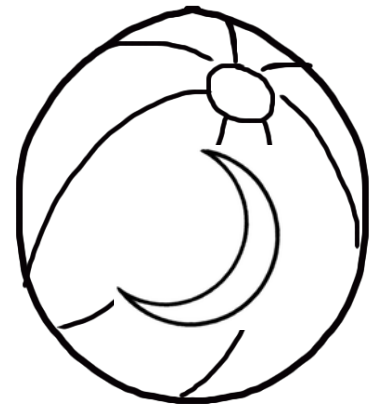
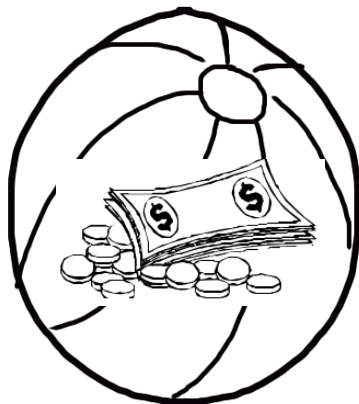
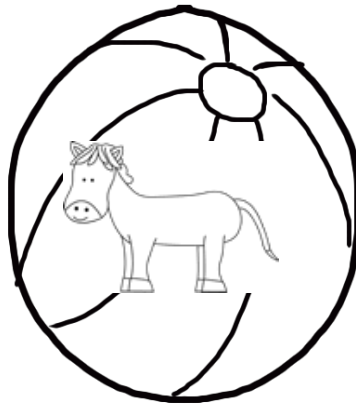
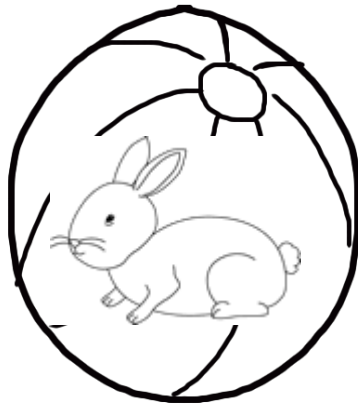
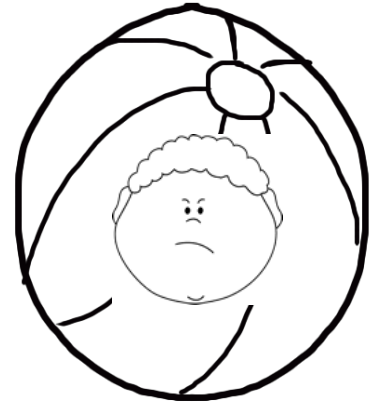
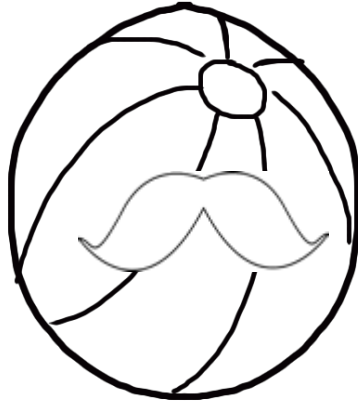
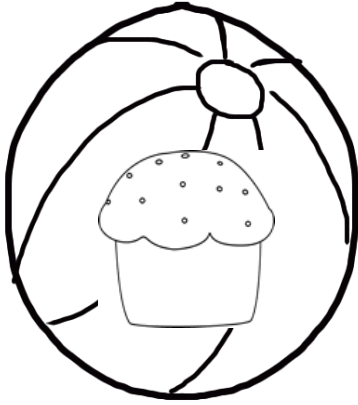

Does it start with T?

Name: _____

Color all of the beach balls that has a picture that starts with the letter T?

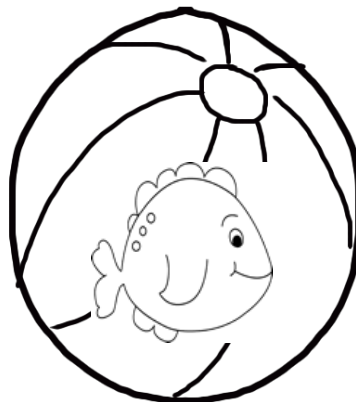
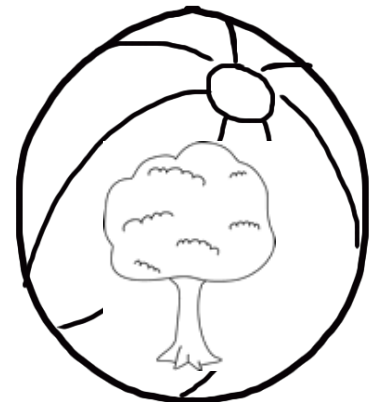
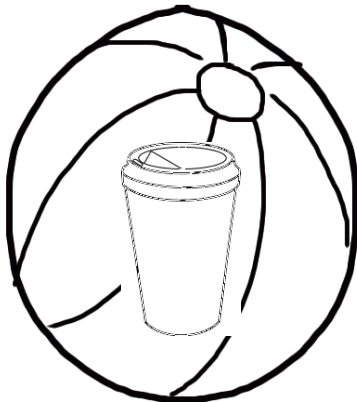
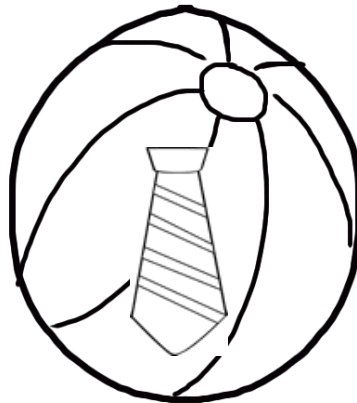
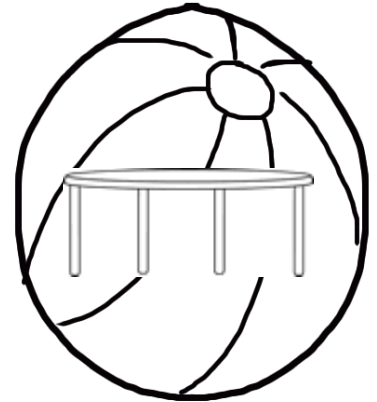
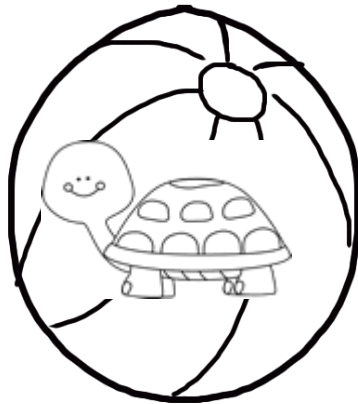
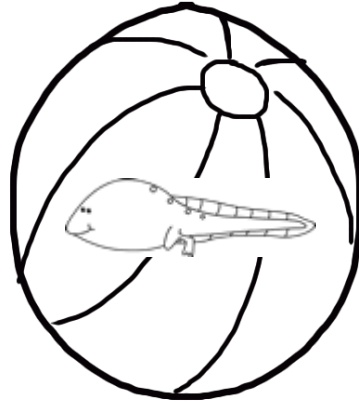
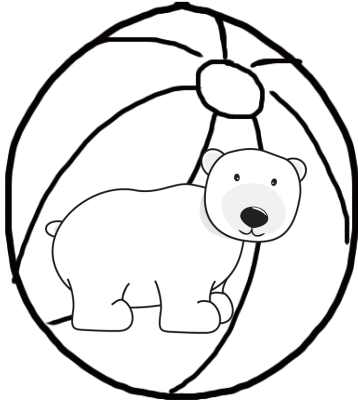

Do they rhyme? Name: _____

Look at the pictures in each row. Circle the pairs of pictures that rhyme.

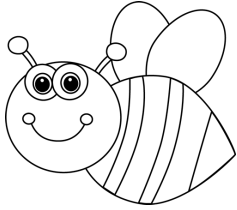

Bee



Cat



Tree

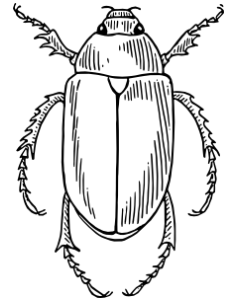

Bug



Hat



Car



Hen



Bat



Dog

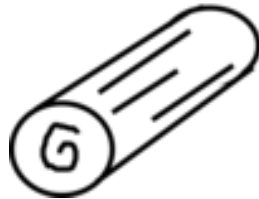

Log

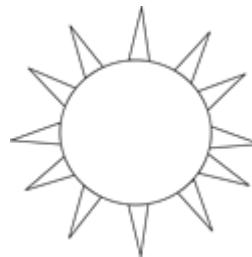

Sun



Cup



Sad



Owl



Mad



Cow

Missing Ending Sounds

Name: _____

Fill in the missing sound for each picture/word.



ca _____



pi _____

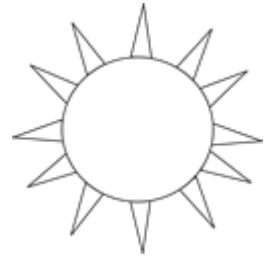

su _____



je _____

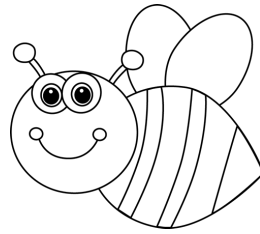

be _____



pe _____



ca _____



fa _____

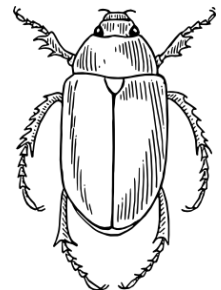

bu _____

Writing Beginning Words

Name: _____

Write each three letter word.





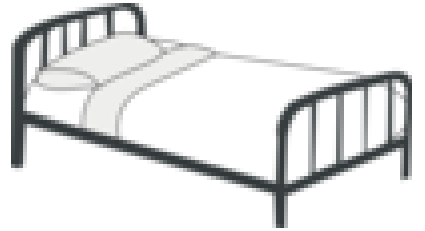

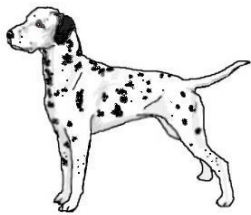







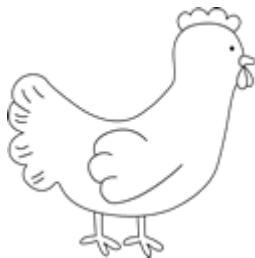



Starting Letters and Sounds Name: _____

What does each picture/word start with? Write the beginning letter.





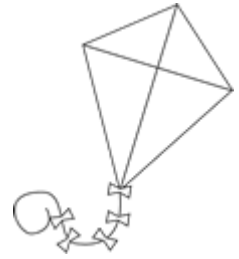



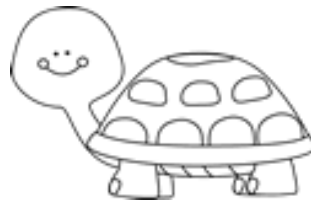







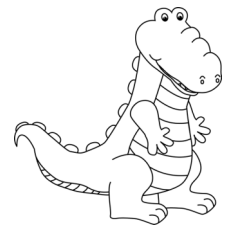

Pete's Colored Swimsuit Matching Color Word Game

Draw a line to match Pete's colored swimsuit to the corresponding color word.

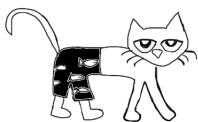

Green

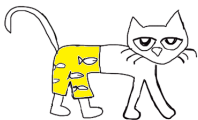

Yellow

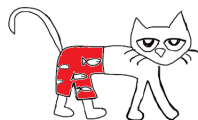

White

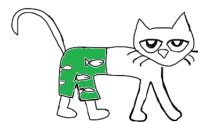

Blue

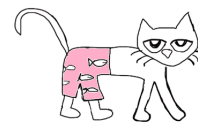

Black



Purple

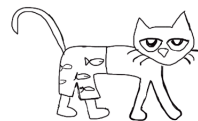

Red



Grey



Orange

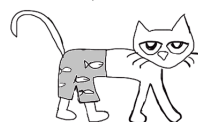

Brown

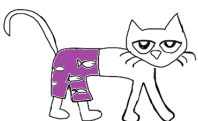

Pink

Pete's Colored Shoes

Name: _____



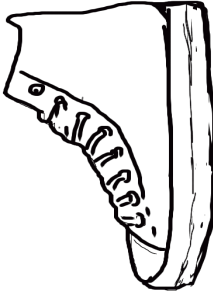
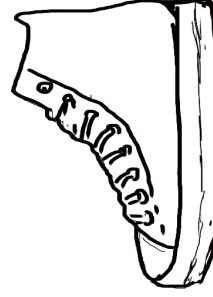
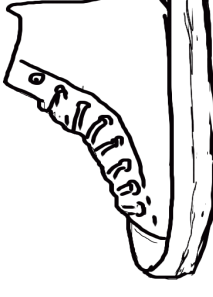
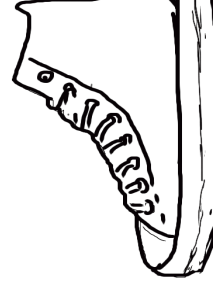
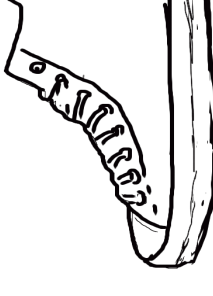
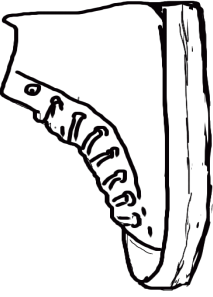
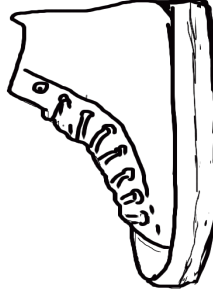
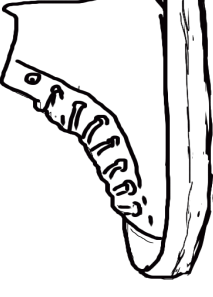
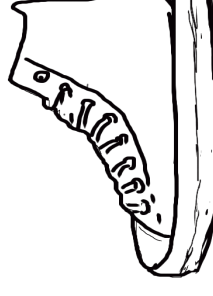
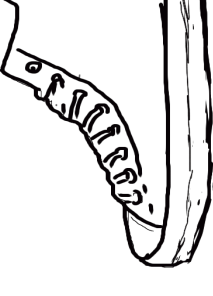

Look at the color word written under Pete's shoes. Color in the shoe the correct color.

				
Red	Green	Yellow	Grey	Brown
				
Blue	Pink	Orange	Black	Purple

Pete's Colored Swim Suit

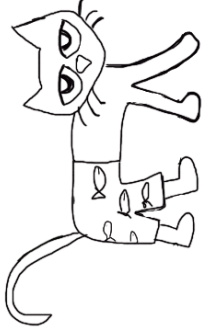
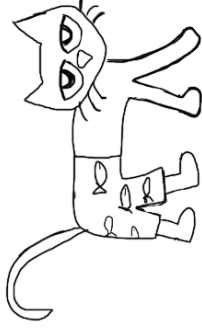
Name: _____

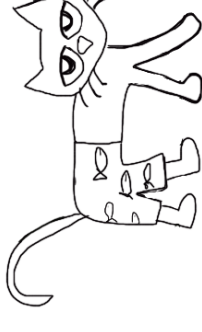
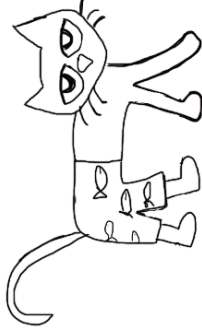
Look at the color word written under Pete. Color his bathing suit the correct color.

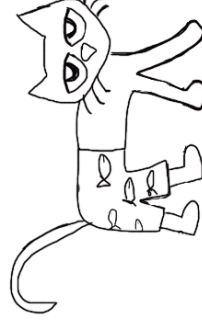
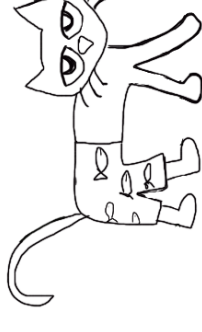
				
Red	Green	Yellow	Grey	Brown
				
Blue	Pink	Orange	Black	Purple

Name _____

Practice writing each letter.

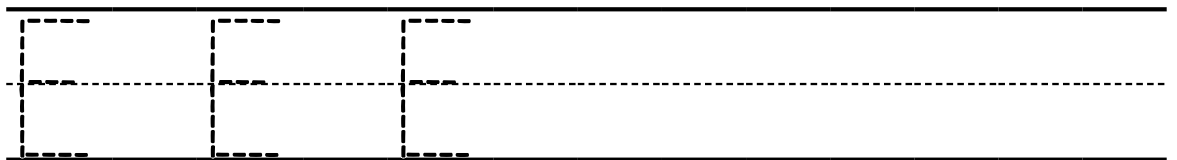
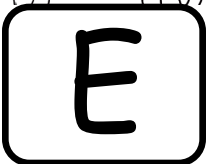
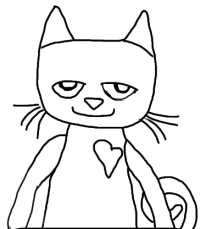
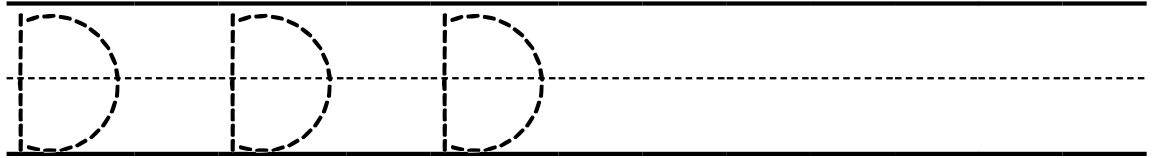
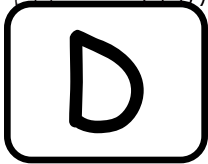
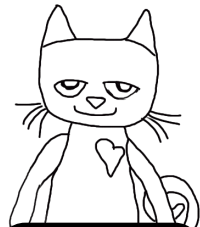
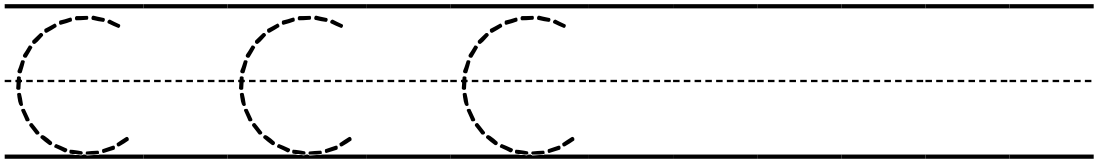
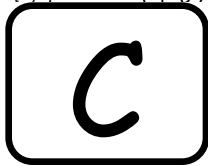
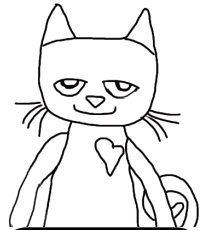
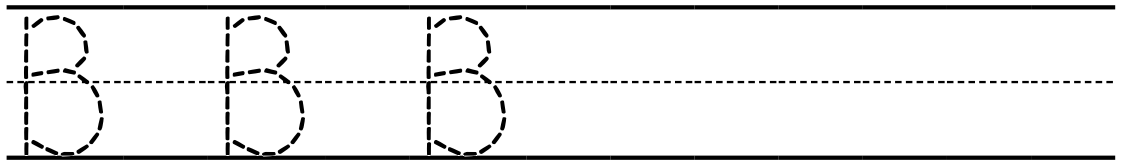
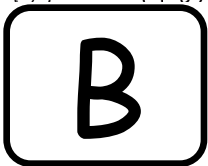
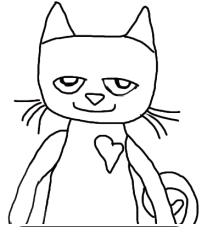
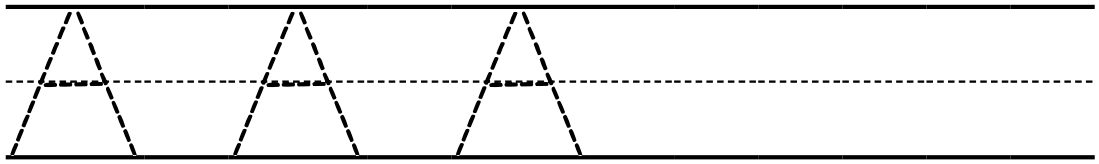
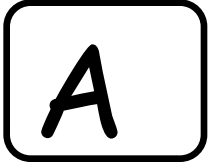
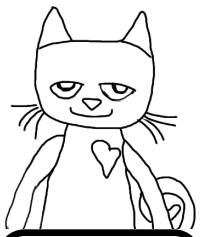

Name _____

Practice writing each letter.

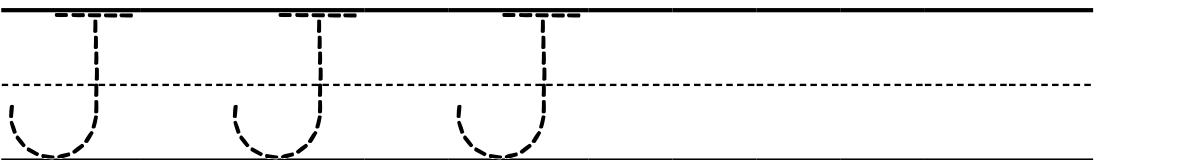
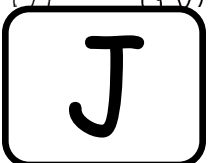
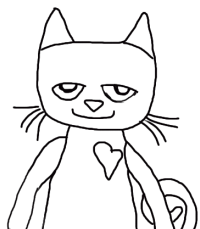
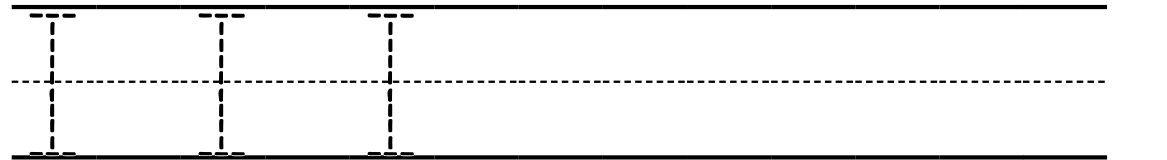
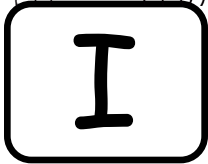
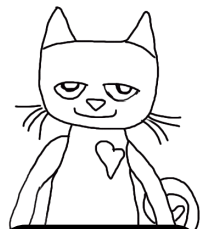
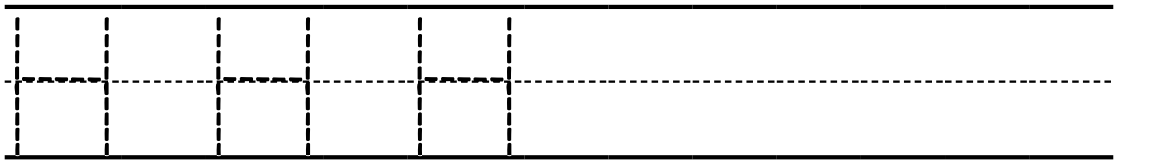
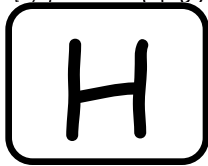
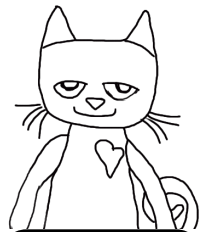
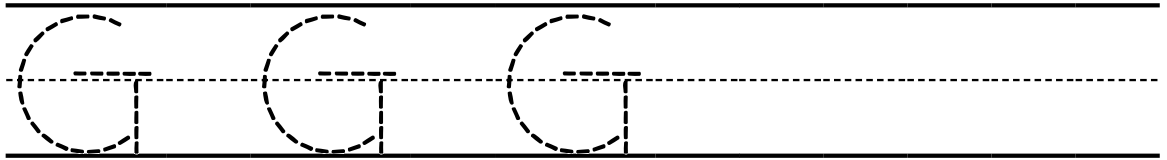
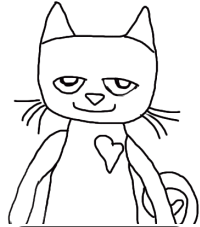
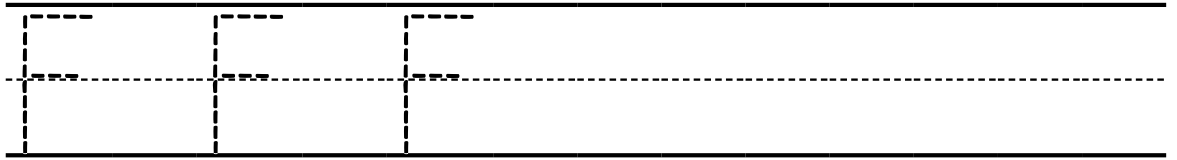
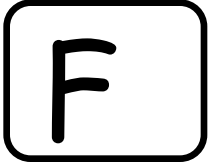
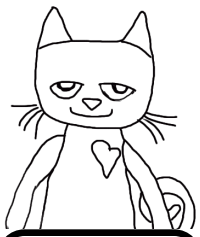

Name _____

Practice writing each letter.

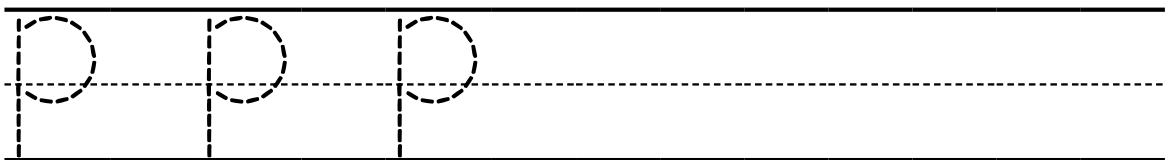
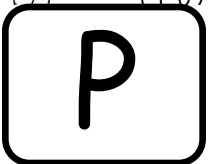
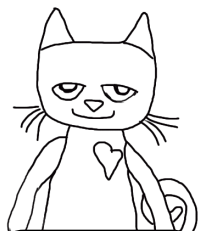
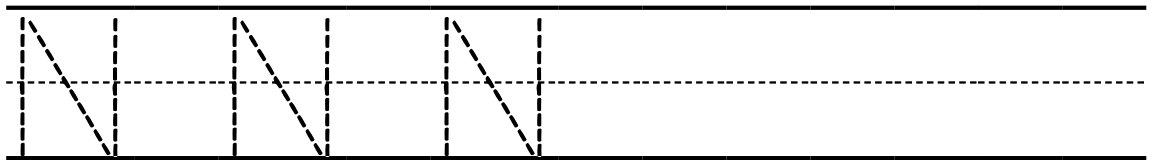
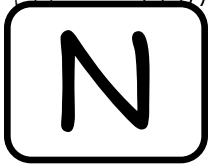
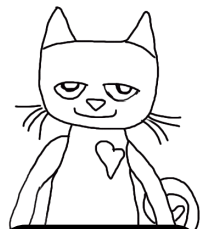
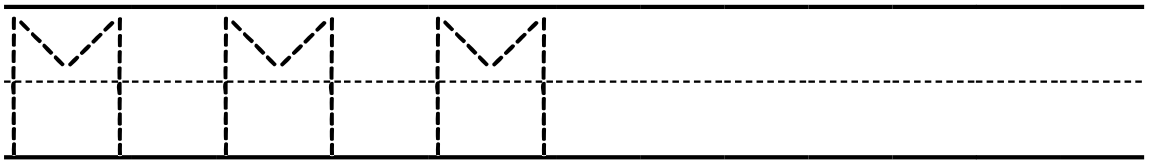
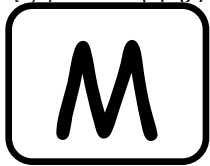
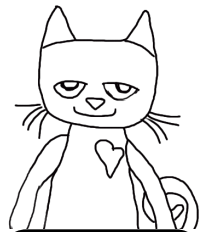
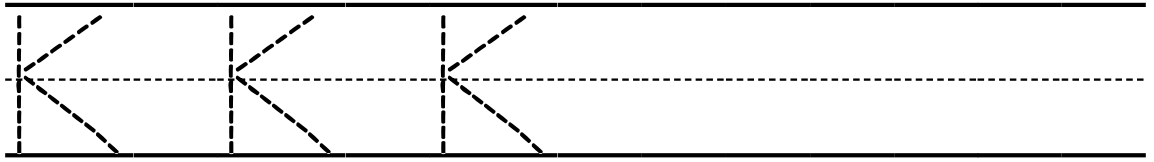
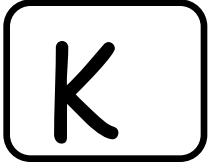
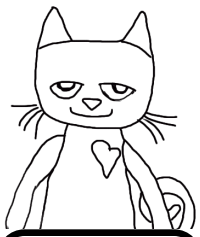

Name _____

Practice writing each letter.

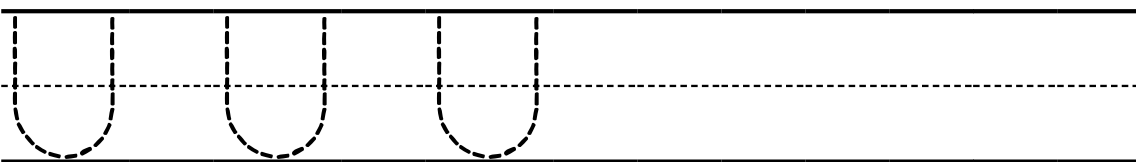
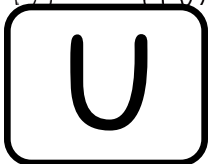
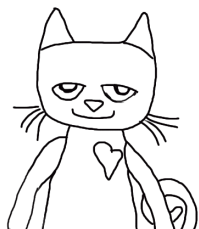
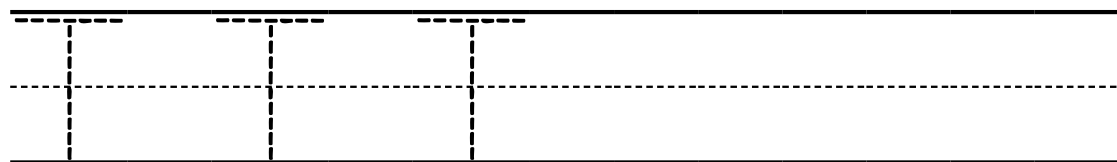
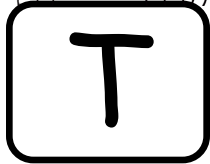
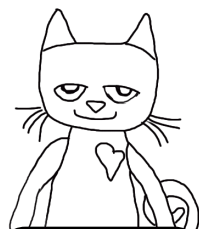
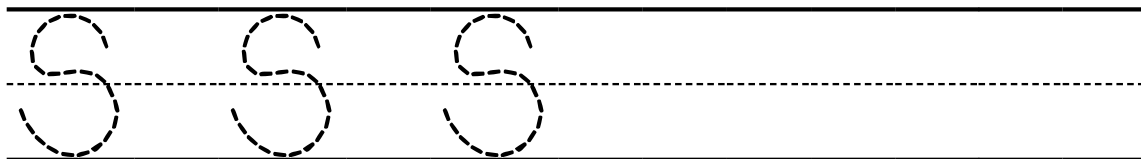
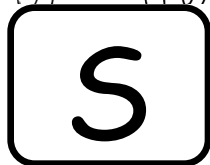
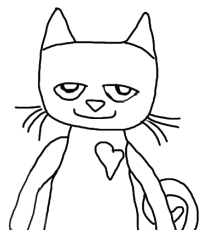
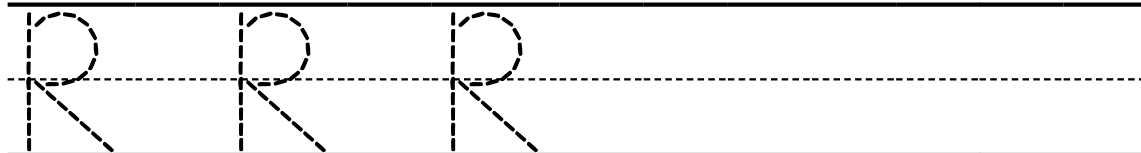
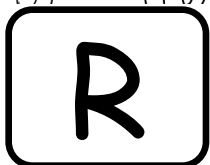
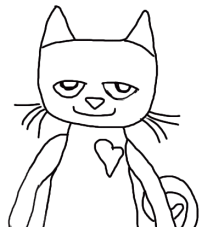
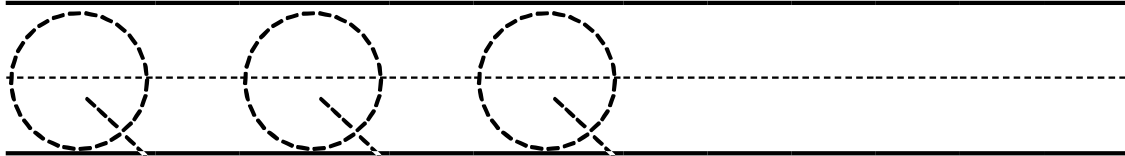
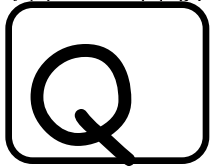
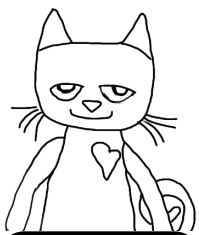

Name _____

Practice writing each letter.

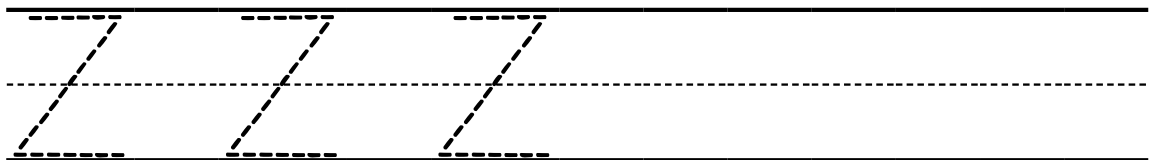
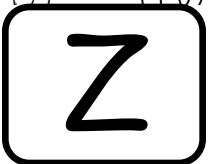
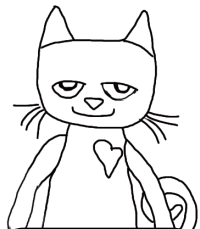
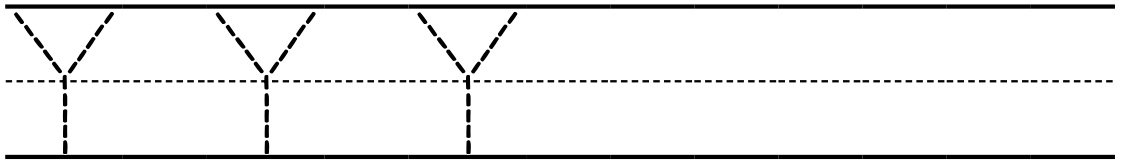
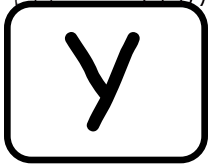
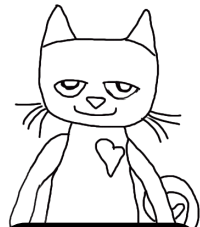
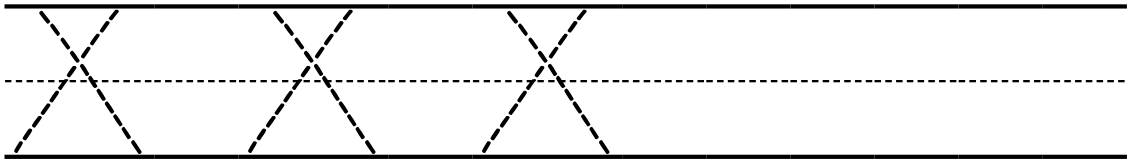
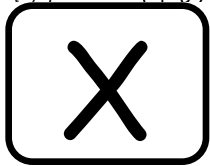
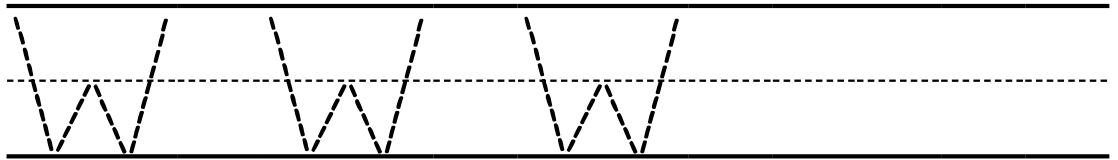
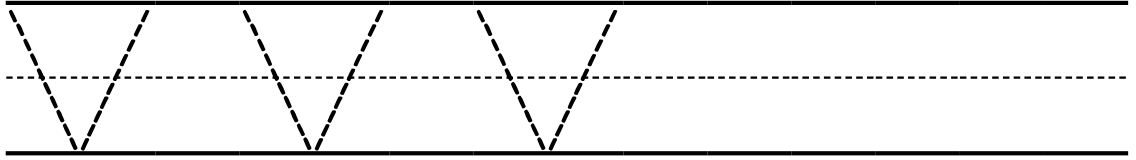
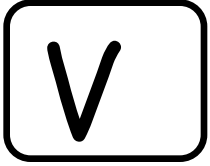
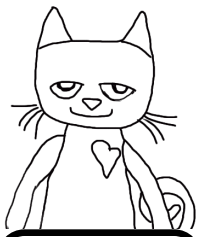

Name _____

Practice writing each letter.

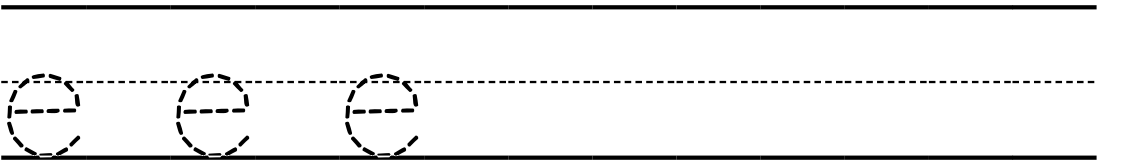
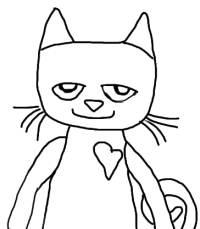
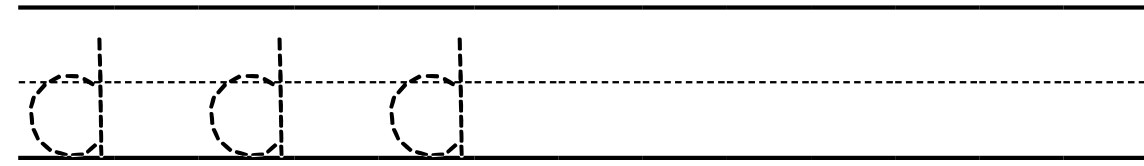
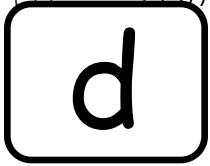
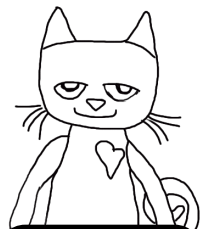
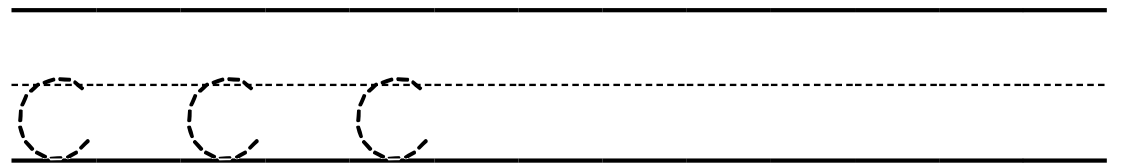
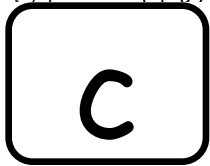
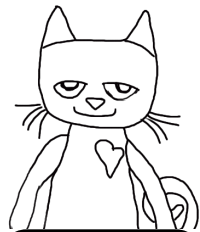
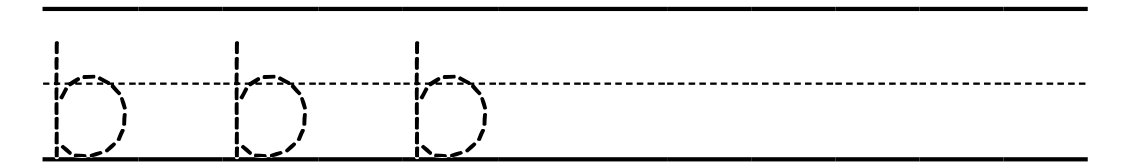
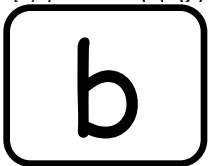
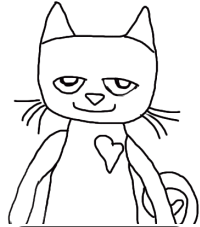
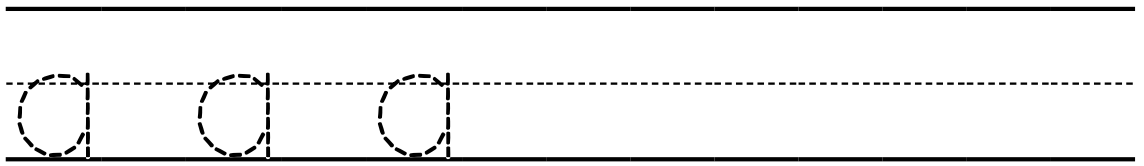
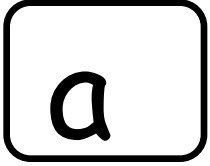
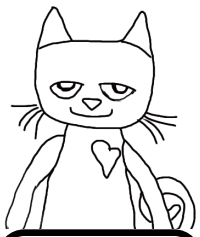

Name _____

Practice writing each letter.

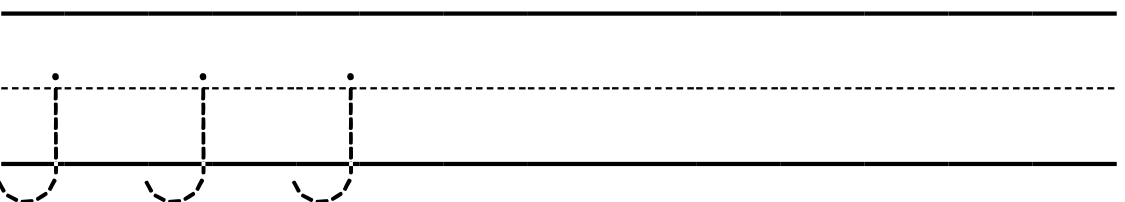
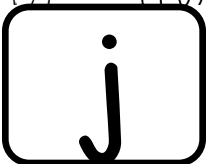
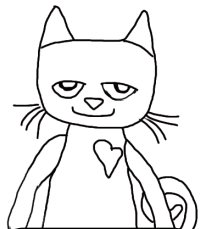
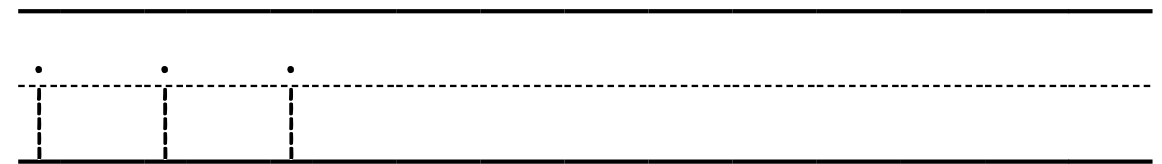
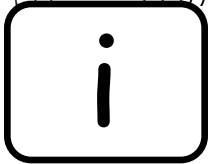
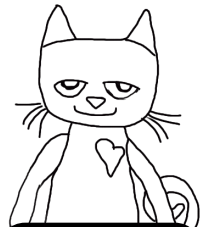
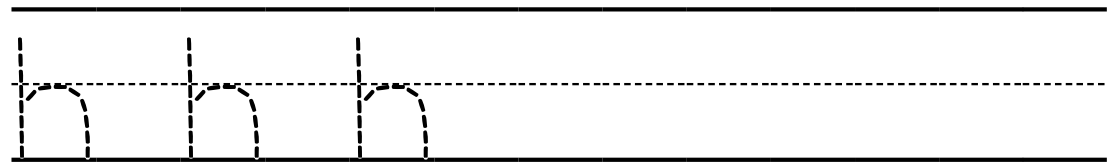
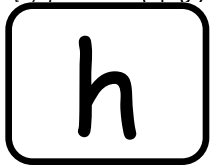
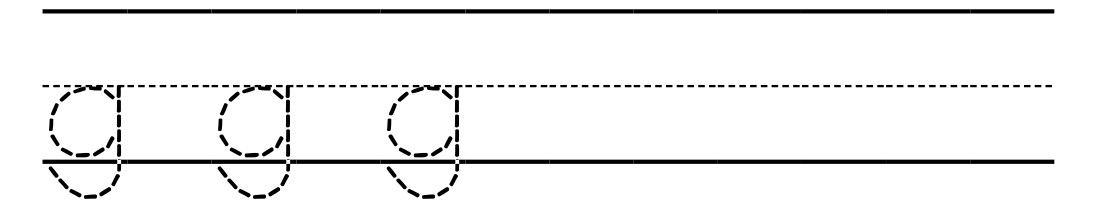
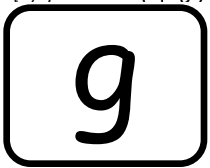
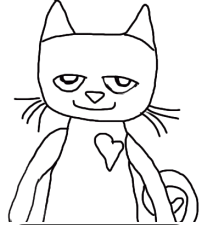
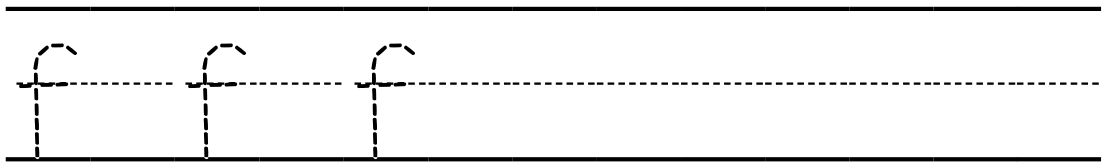
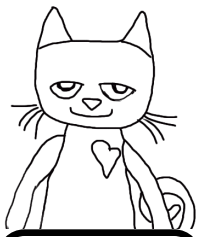

Name _____

Practice writing each letter.

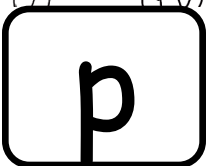
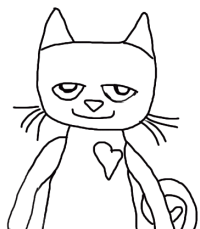
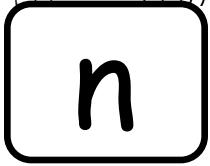
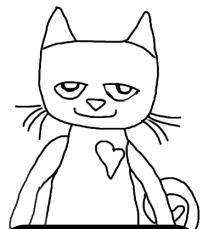
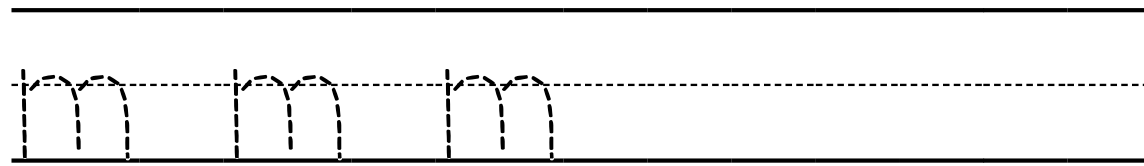
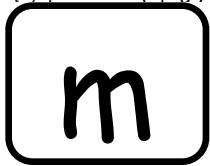
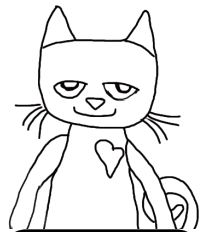
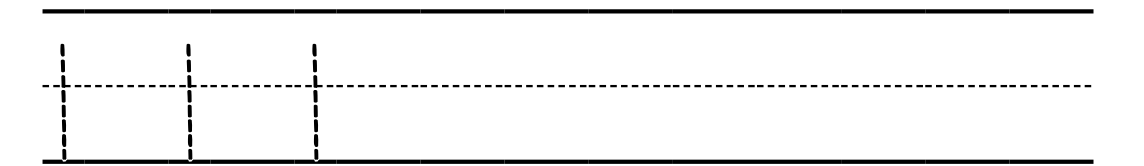
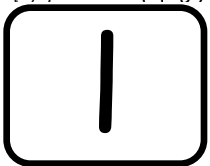
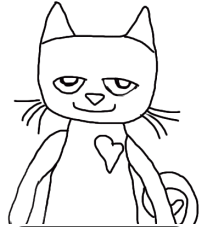
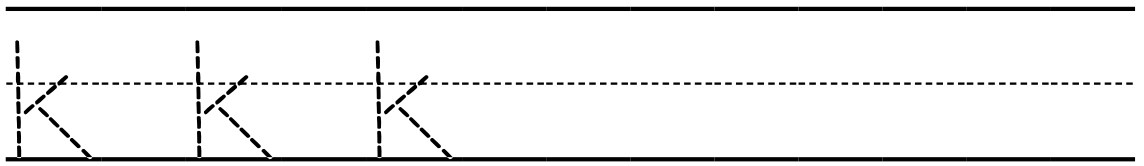
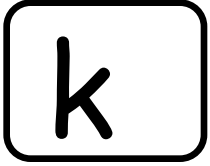
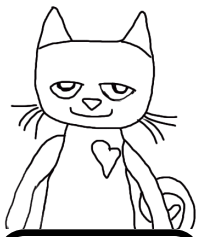

Name _____

Practice writing each letter.

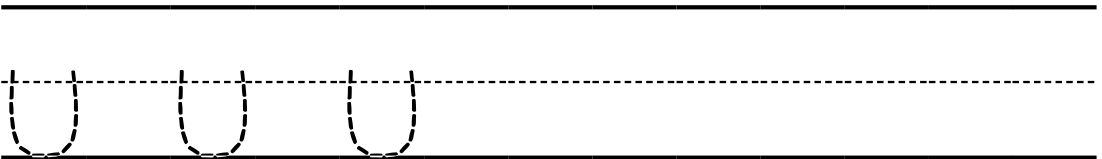
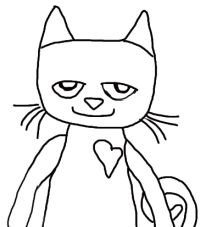
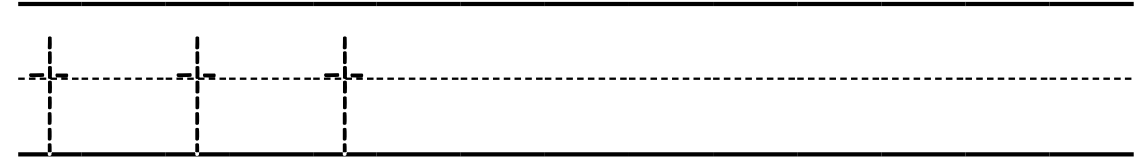
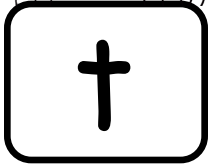
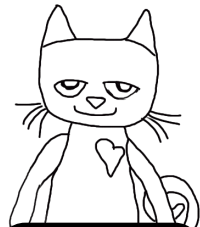
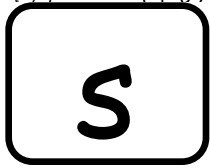
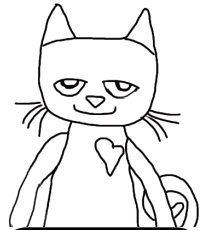
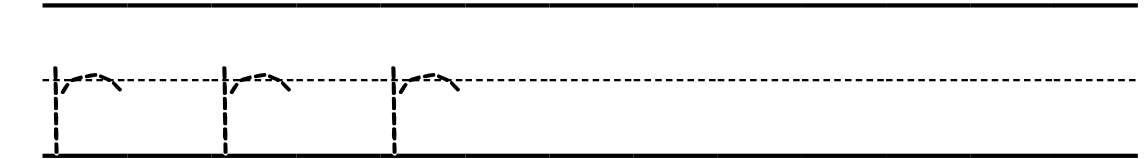
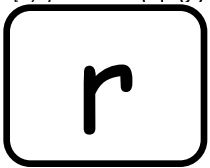
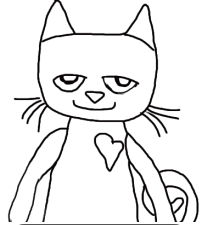
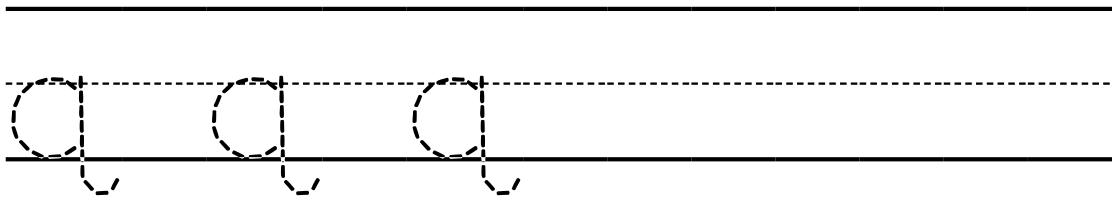
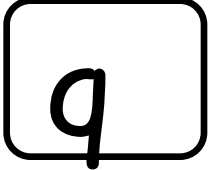
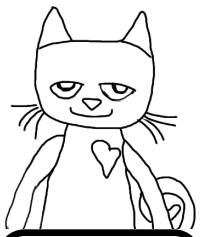

Name _____

Practice writing each letter.

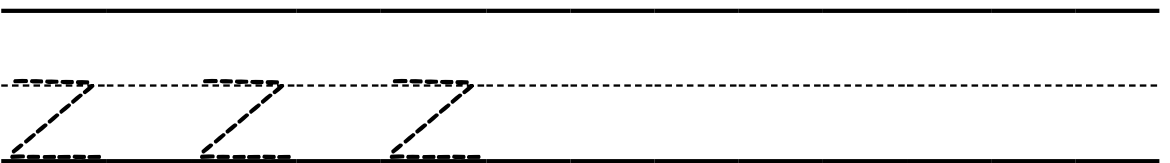
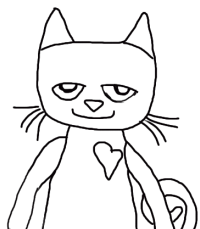
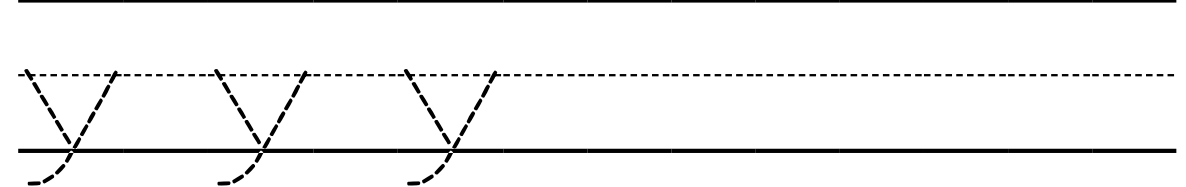
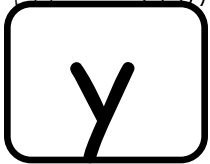
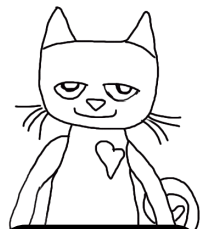
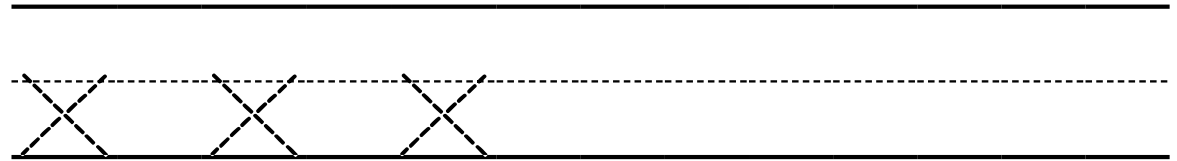
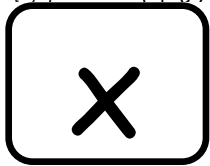
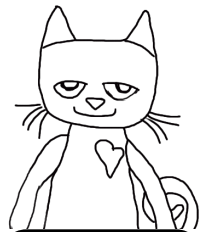
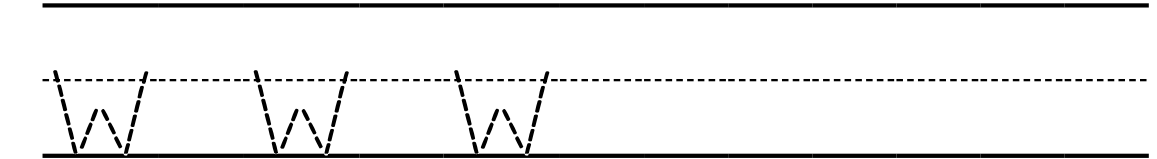
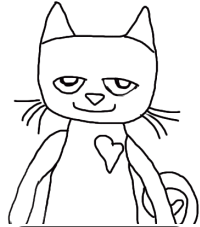
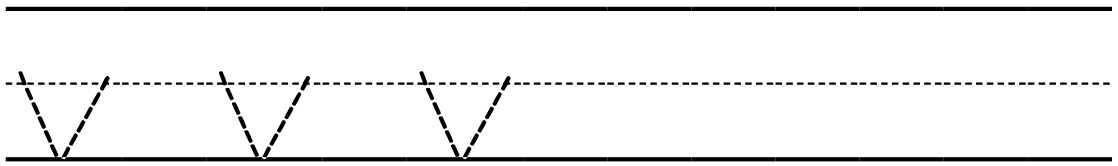
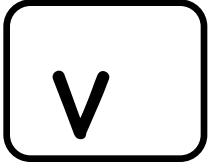
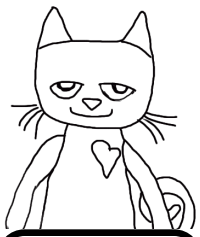

Catching balls with Pete!

Name _____

Color all the balls that have a picture with the **M** sound.

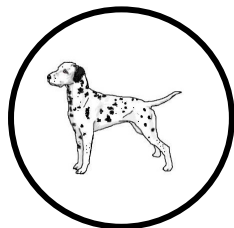
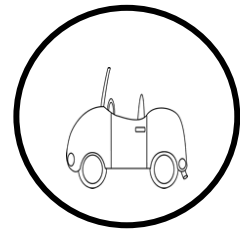
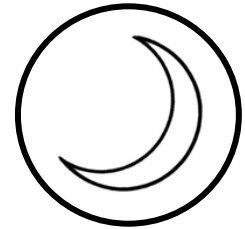
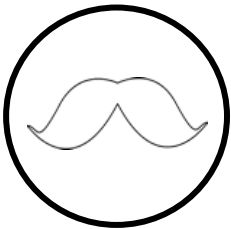

Catching balls with Pete!

Name _____

Color all the balls that have a picture with the **W** sound.

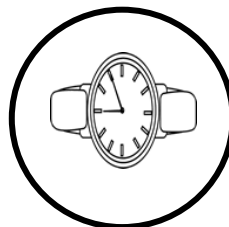
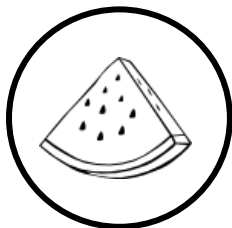
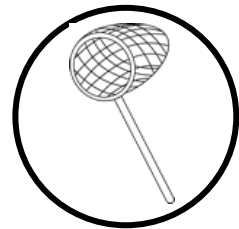
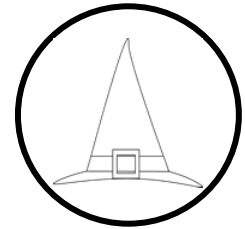
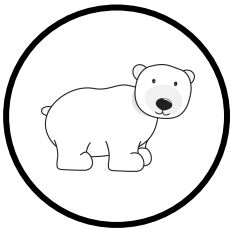
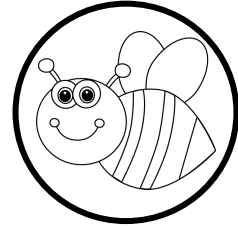
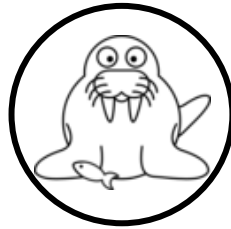
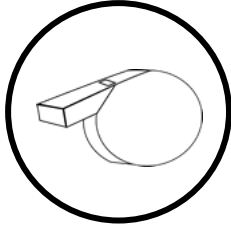

Catching balls with Pete!

Name _____

Color all the balls that have a picture with the F sound.

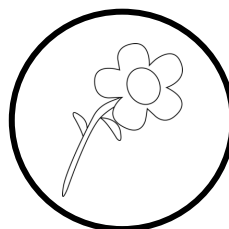
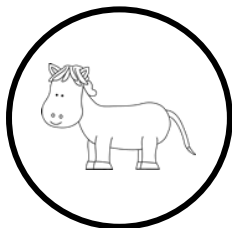
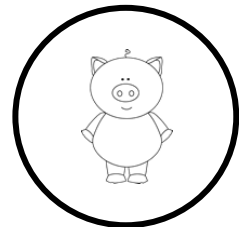
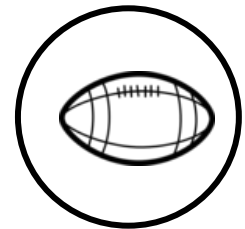
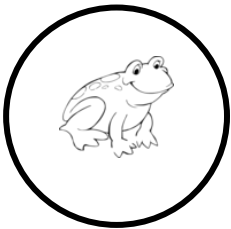
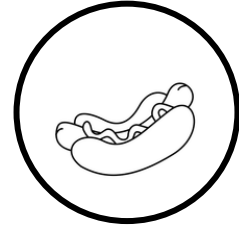

Catching balls with Pete!

Name _____

Color all the balls that have a picture with the L sound.

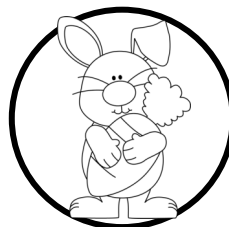
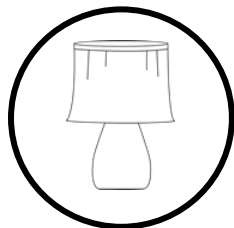
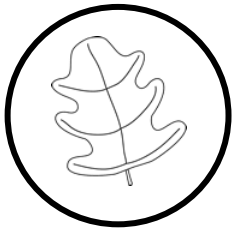
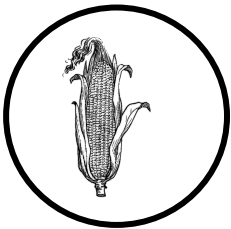
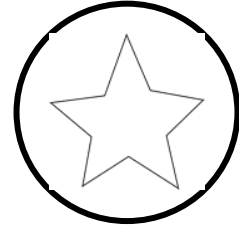
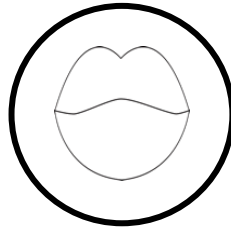
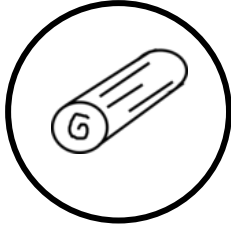

Catching balls with Pete!

Name _____

Color all the balls that have a picture with the V sound.

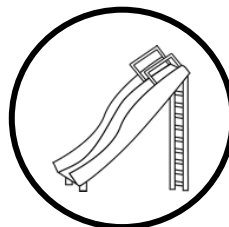
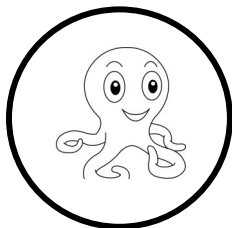
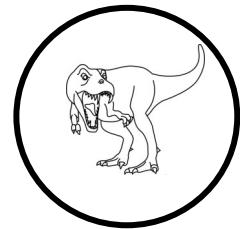
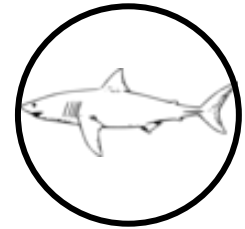
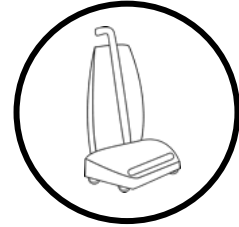
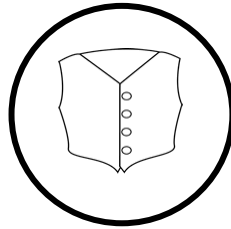

Tractor line up!

Name _____

Fill in the letters that are missing.

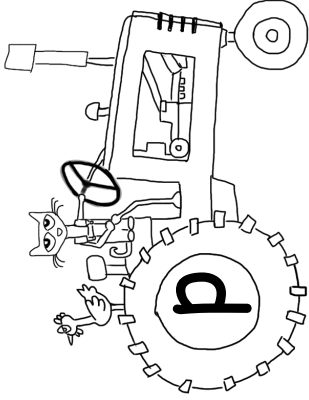
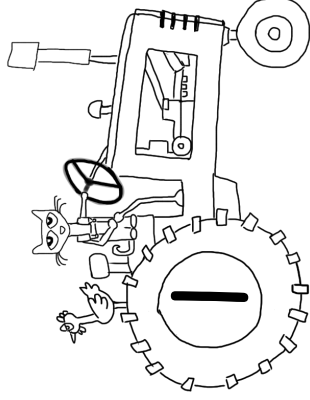
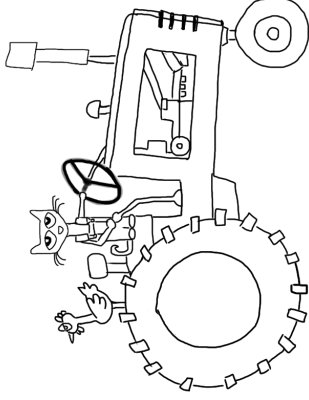
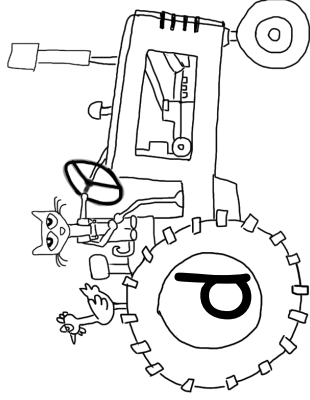
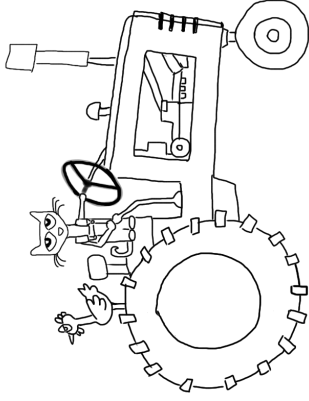
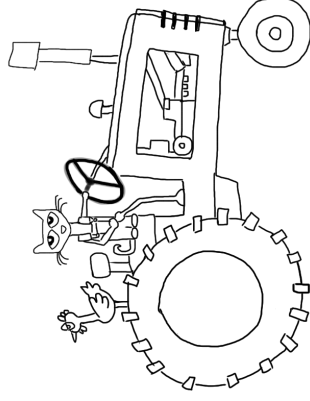
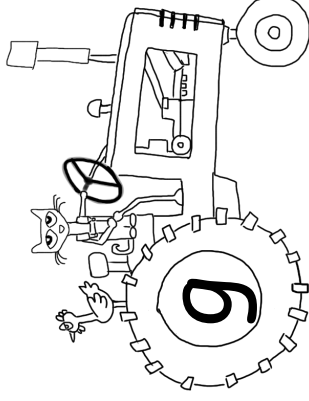
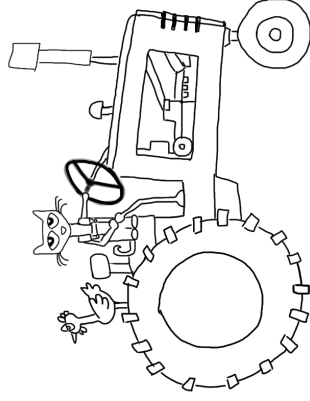
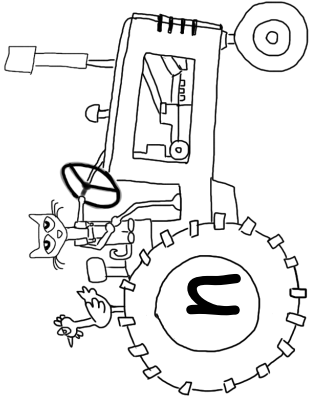
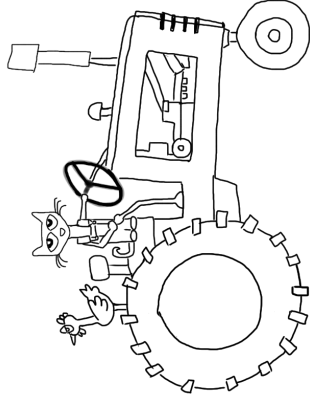
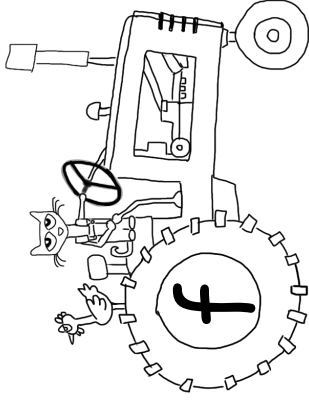
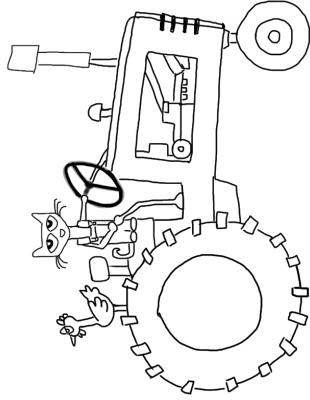
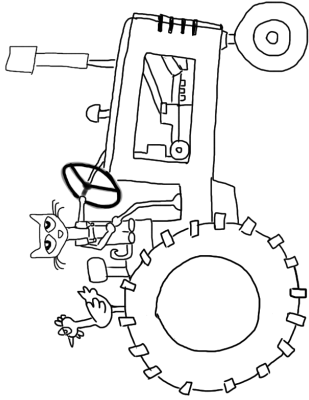
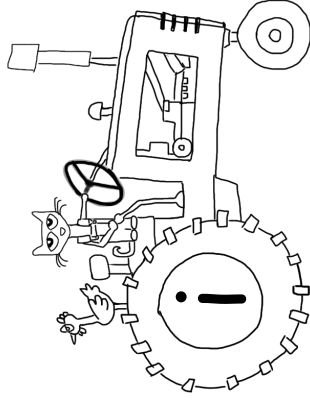
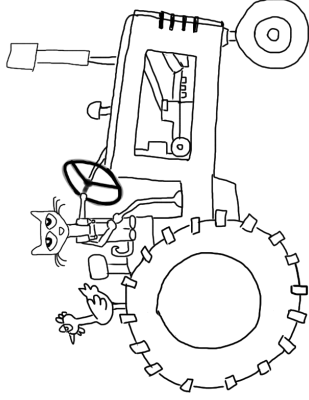
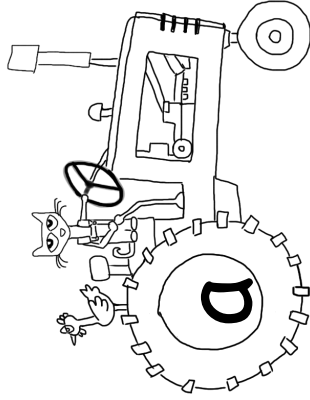

Tractor line up!

Name _____

Fill in the letters that are missing.

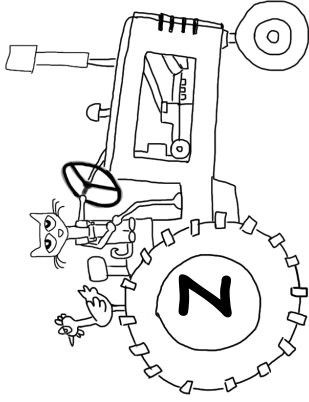
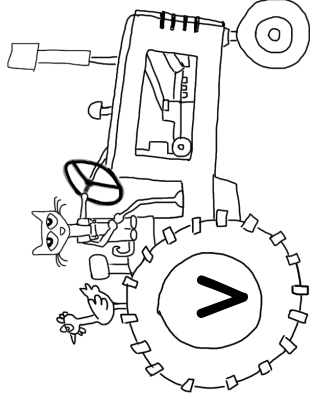
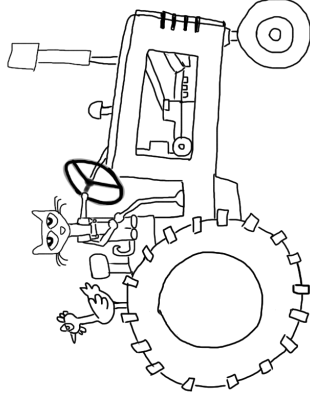
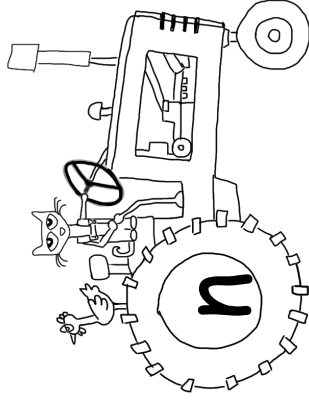
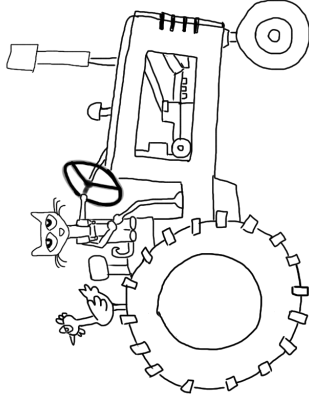
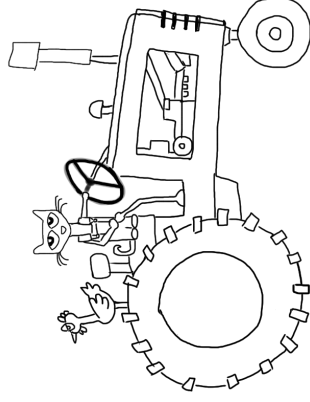
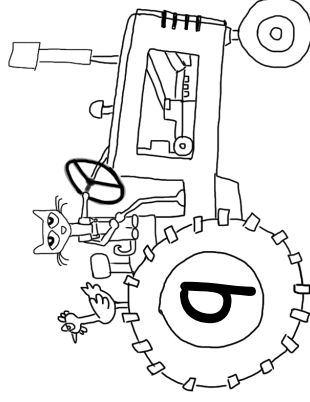
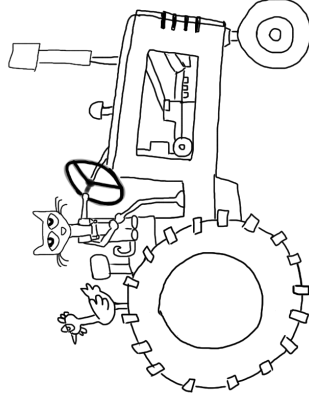
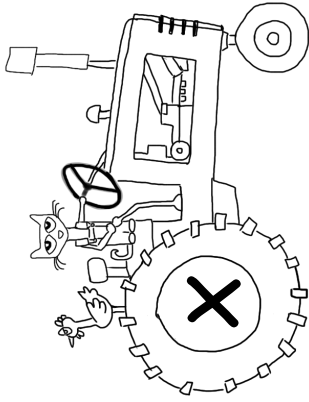
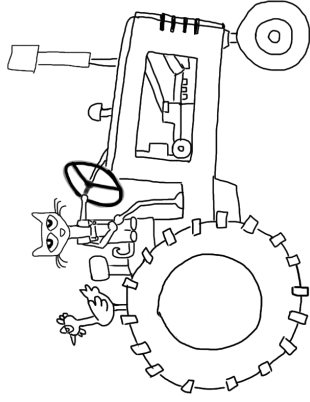
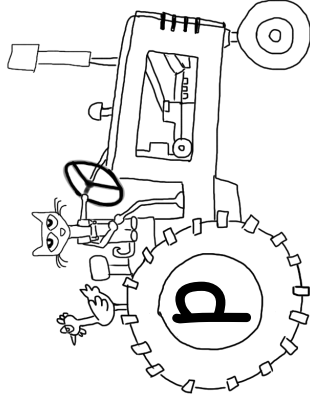
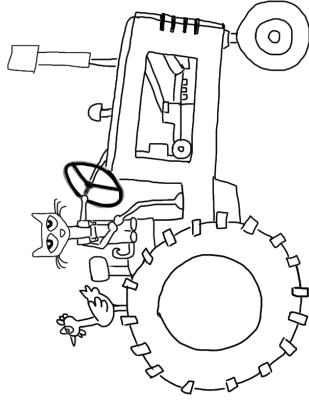
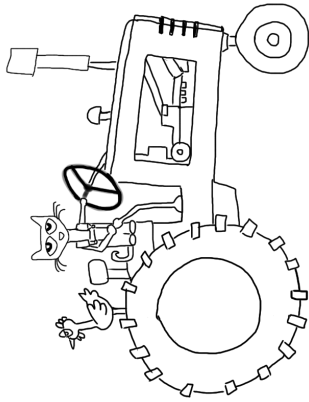
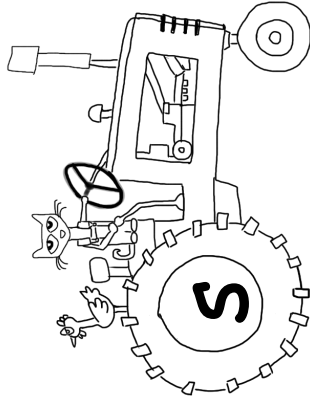
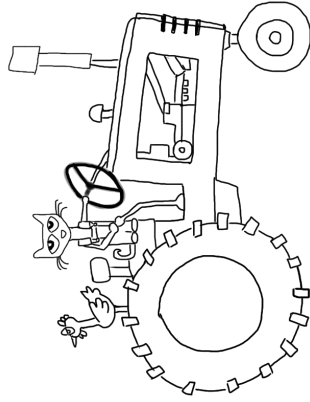
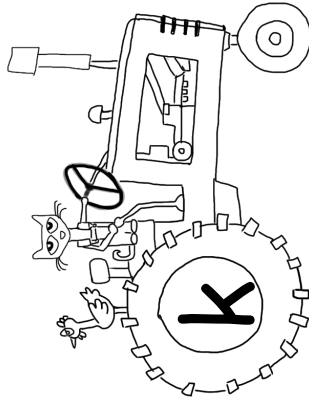

Tractor line up!

Name _____

Fill in the letters that are missing.

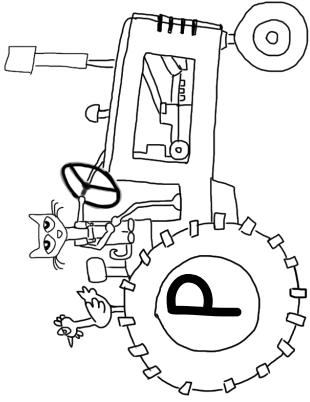
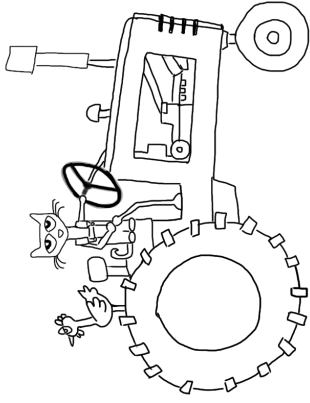
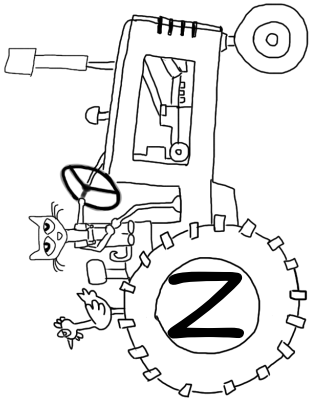
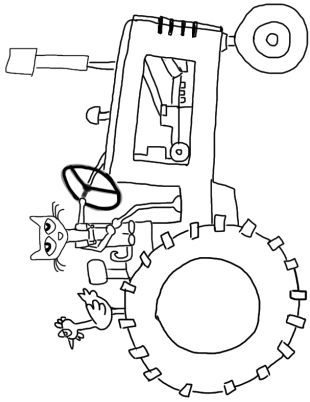
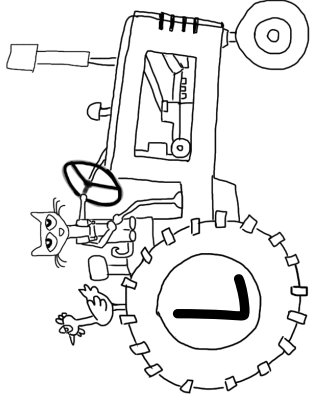
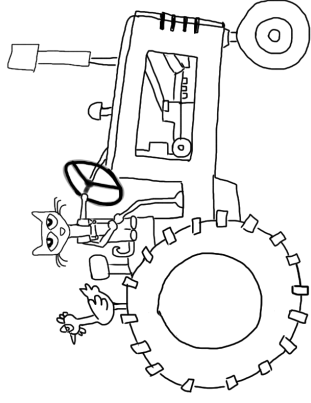
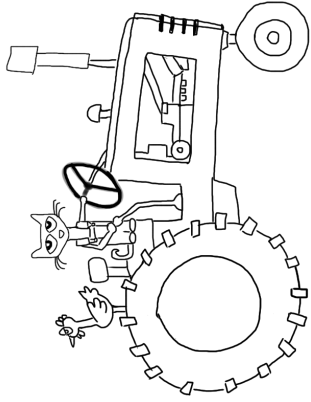
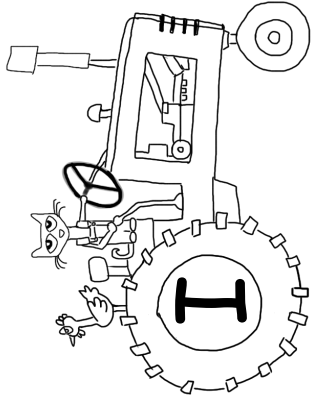
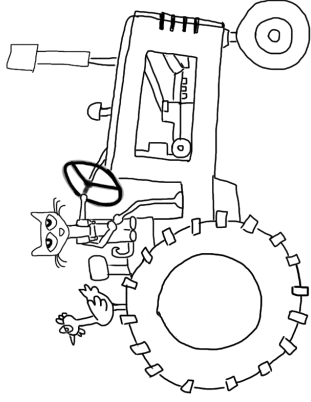
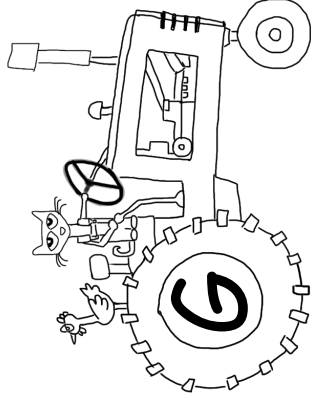
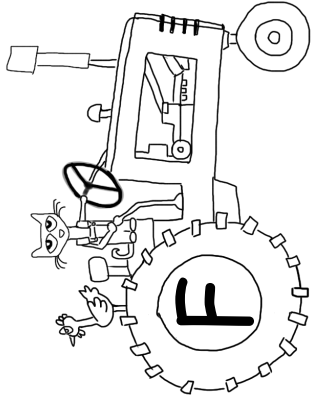
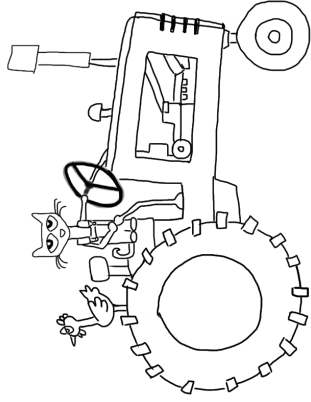
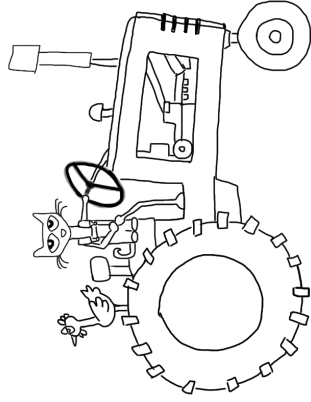
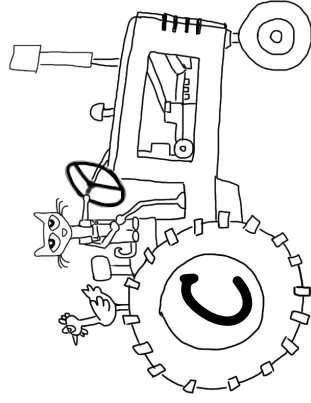
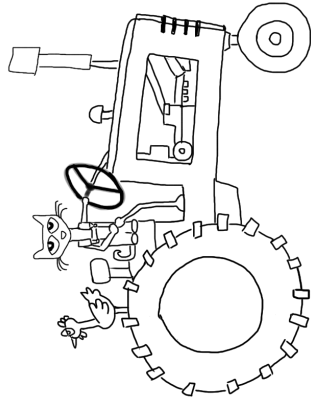
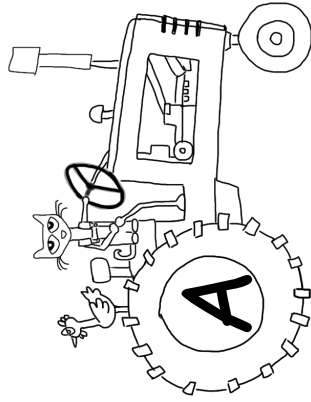

Tractor line up!

Name _____

Fill in the letters that are missing.

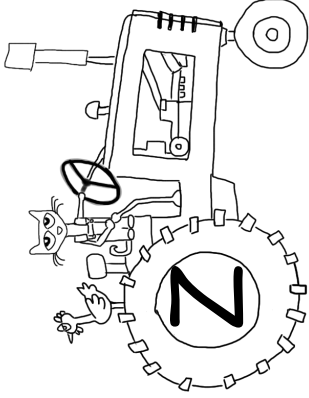
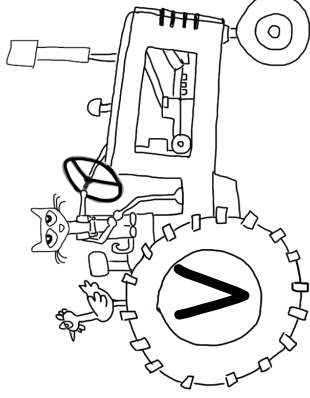
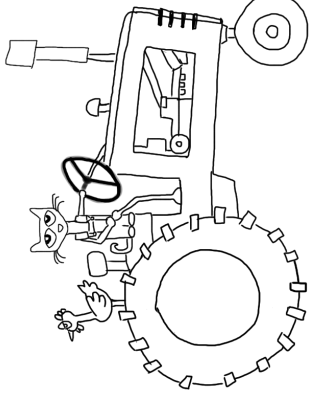
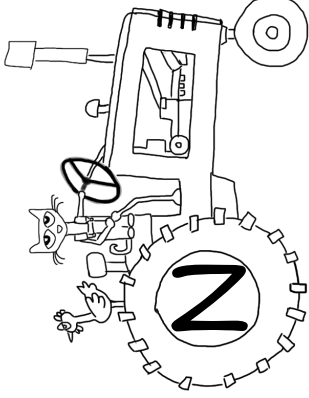
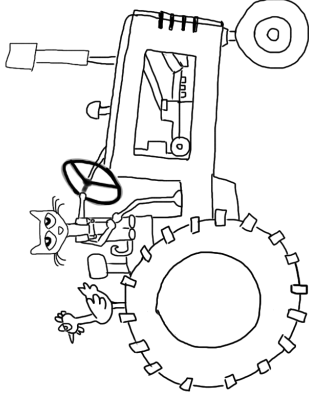
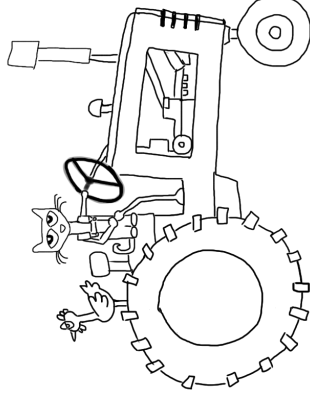
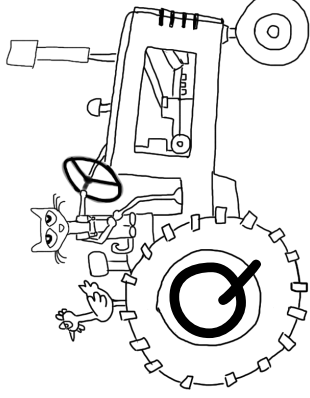
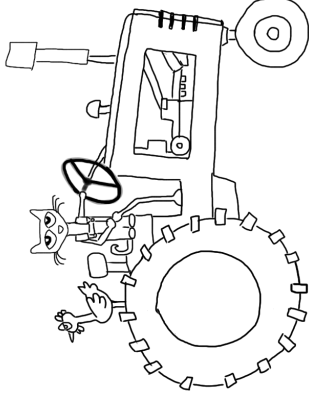
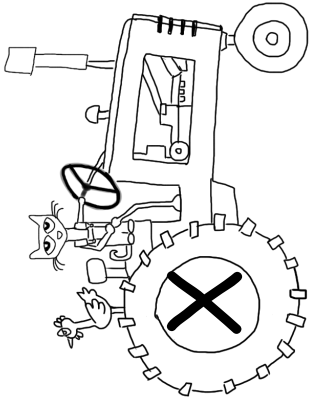
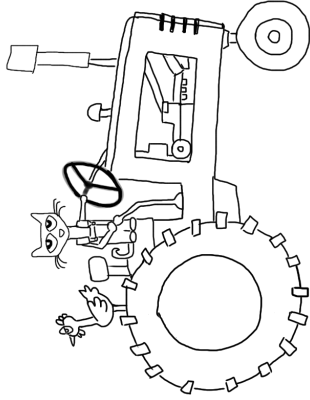
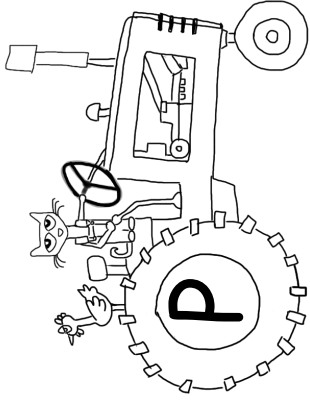
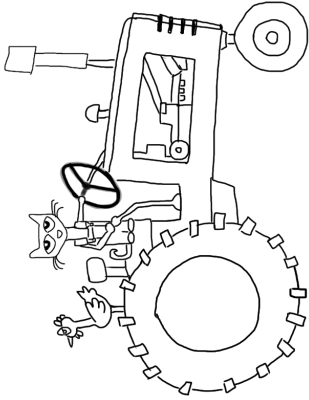
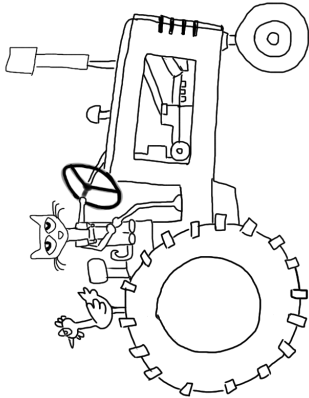
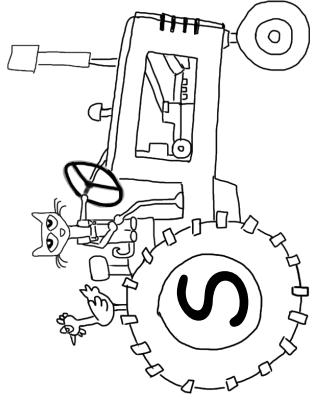
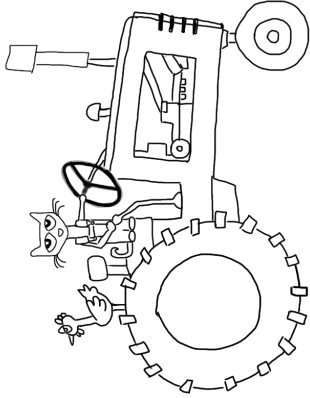
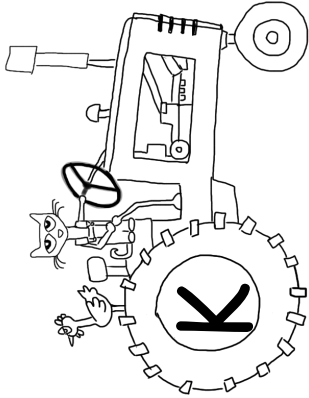

Many parents ask “What do you do when my child learns the letters and sounds of the alphabet?”. The next step is learning sight words. Being able to recognize sight words is important because these words make up between 50-70% of the words we encounter in text. Sight words must be quickly recognized in order to read fluently. Many of these words cannot be “sounded out”. Learning sight words can be difficult, but you as the parent you can make it fun this summer! We know children learn best when we use many sensory strategies. This means that children are more likely to learn and remember when we provide opportunities to use as many of the senses as possible when we teach a skill. Try using these multi-sensory activities to teach your child sight words.

- ◆ **Glitter Words**—Make a word with glitter glue. Wait until the glue hardens, and have him/her trace the letters while saying the letter name and then the word (“t” “h” “e” - “the”).
- ◆ **Yarn Words**--Have your child use glue to make the word and then place yarn over the glue.
- ◆ **Fun with Playdoh**—Use Playdoh to make a word.
- ◆ **Wordo**—Played just like the game Bingo, but this version uses sight words instead of numbers on a grid card.
- ◆ **Concentration**—Sight word concentration cards can easily be made using index cards. Simply write each word on two cards, shuffle and lay face down to play.
- ◆ **Wordall**—Create word searches featuring sight words attached and hide them all around the house.
- ◆ **Wikki Stix**— Wikki Stix are wax covered sticks that can be easily bent into shapes. Bendaroos also work great and can be found in most stores.
- ◆ **Fun at the Beach**—Have your child trace words in sand. I use meat trays and craft sand. Local butchers often are willing to give you a few meat trays for free.
- ◆ **A Work of Art**—Plastic canvas can be purchased at a craft store. Have your child place paper over the canvas and write a word with a crayon. When the canvas is taken away, the word is “bumpy”.
- ◆ **Words with Daddy**—Of course, shaving cream is a popular multi-sensory activity!
- ◆ **Move with Words**—Incorporating movement into learning sight words is also fun. Try having your child jump, hop, clap or tap out the letters of a sight word.
- ◆ **Hopscotch**— make an old fashioned hopscotch game with chalk in the driveway and write sight words in each box.
- ◆ **Go Fish**—Go fish cards can easily be made using index cards. Simply write each word on two cards, shuffle and deal to play.
- ◆ **Letter Magnet Spelling**—To reinforce sight word spelling, provide the child with a set of letter magnets and a metal surface. Call out sight words and ask the child to use the magnets to spell the word.

Have fun teaching sight words!

in

and

to

of

a

the

that

was

you

he

is

it

for

as

on

with

are

his

they

be

I

this

at

have

from

had

or

by

one

words

but

all

not

were

what

we

when

said

your

there

can

use

an

she

each

do

which

how

will

if

their

look

so

up

What's the Weather?

Draw a picture of the weather for each day this week. Write one of the weather words.

Sunny 	Cloudy 	Rainy 	Windy 	Foggy 
--	---	--	--	--

Day of the Week	Picture of the weather	Write the weather word
Sunday		
Monday		
Tuesday		
Wednesday		
Thursday		
Friday		
Saturday		

Summer Weather Tally for the Month of **JUNE**

Have your child make a tally mark on the chart each day showing what the weather is like.

Rainy



Sunny

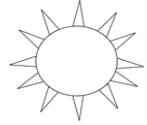

Cloudy



Sunny and Cloudy



Windy

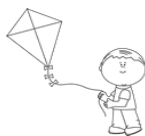

Foggy



Summer Weather Tally for the Month of **JULY**

Have your child make a tally mark on the chart each day showing what the weather is like.

Rainy



Sunny

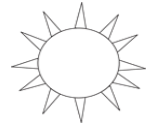

Cloudy



Sunny and Cloudy



Windy

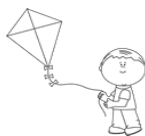

Foggy



Summer Weather Tally for the Month of **AUGUST**

Have your child make a tally mark on the chart each day showing what the weather is like.

Rainy



Sunny



Cloudy



Sunny and Cloudy



Windy

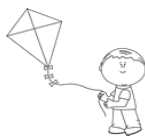

Foggy



Is it Summer?

Name _____

Circle the picture in each box that represents Summer.

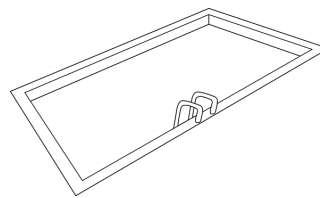
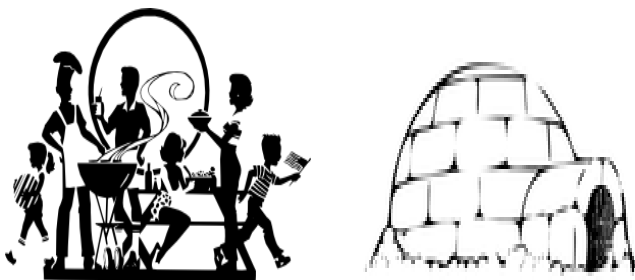
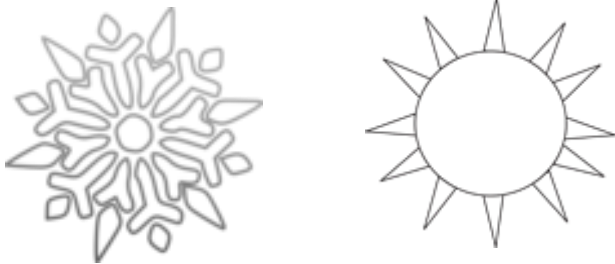
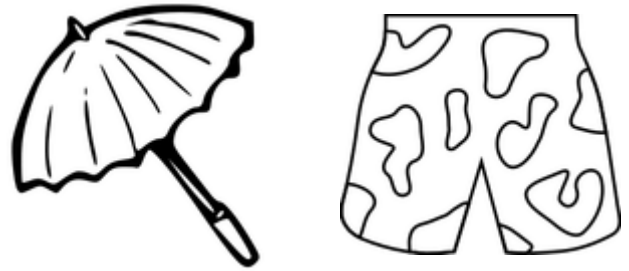
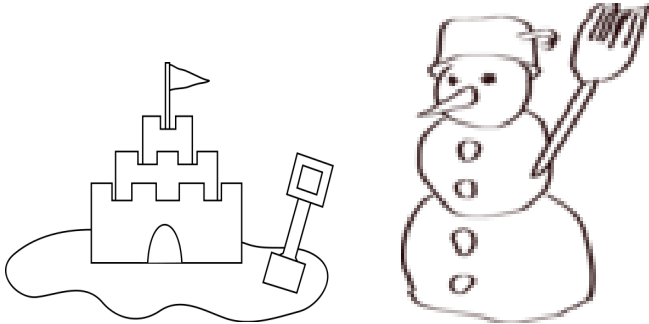

Is it Summer? Name: _____

Circle the pictures that represent SUMMER.

Place an X on the pictures that represent WINTER.

Underline the pictures that show SPRING OR FALL.

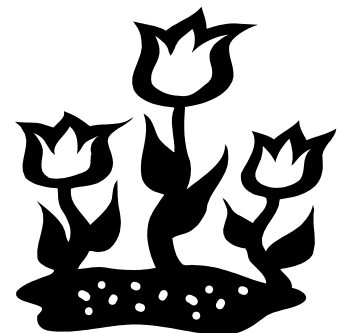
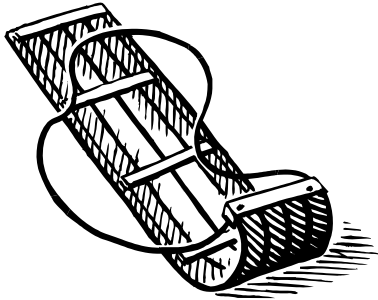

Who Lives in the Ocean? Name: _____

Circle all of the animals that live in the ocean.

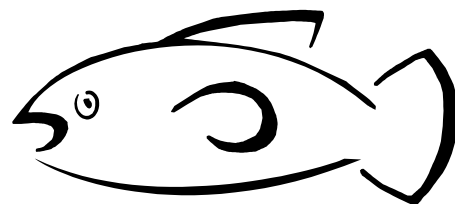
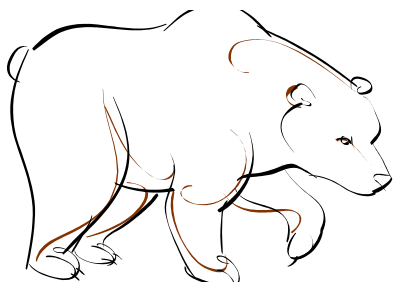
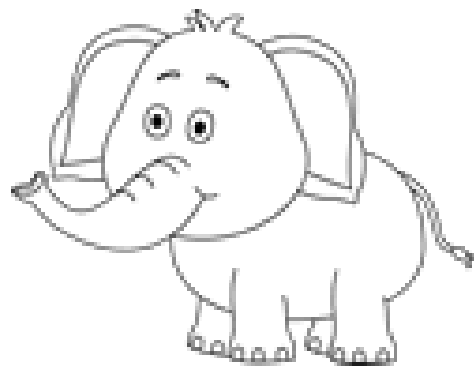
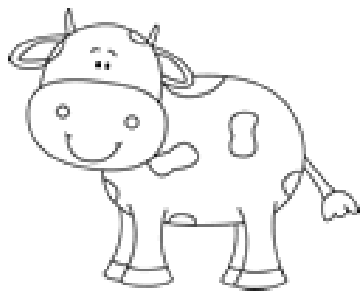
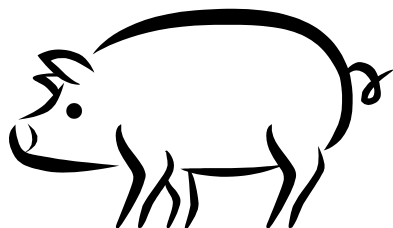

5 Senses at the Ocean? Name: _____

Write as many words as you can to describe the ocean using your five senses.

Smells like

Sounds like

Tastes like

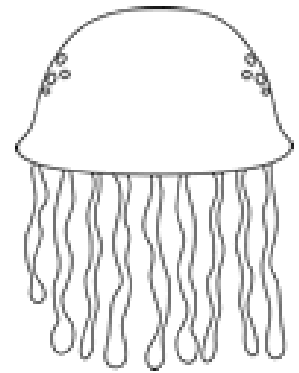

Feels like

Looks like

Float or Sink? Name: _____

Look at the list of different objects. If an object would float in water write the word **ABOVE** the water line. If the object sinks, write the word **BELOW** the water line.

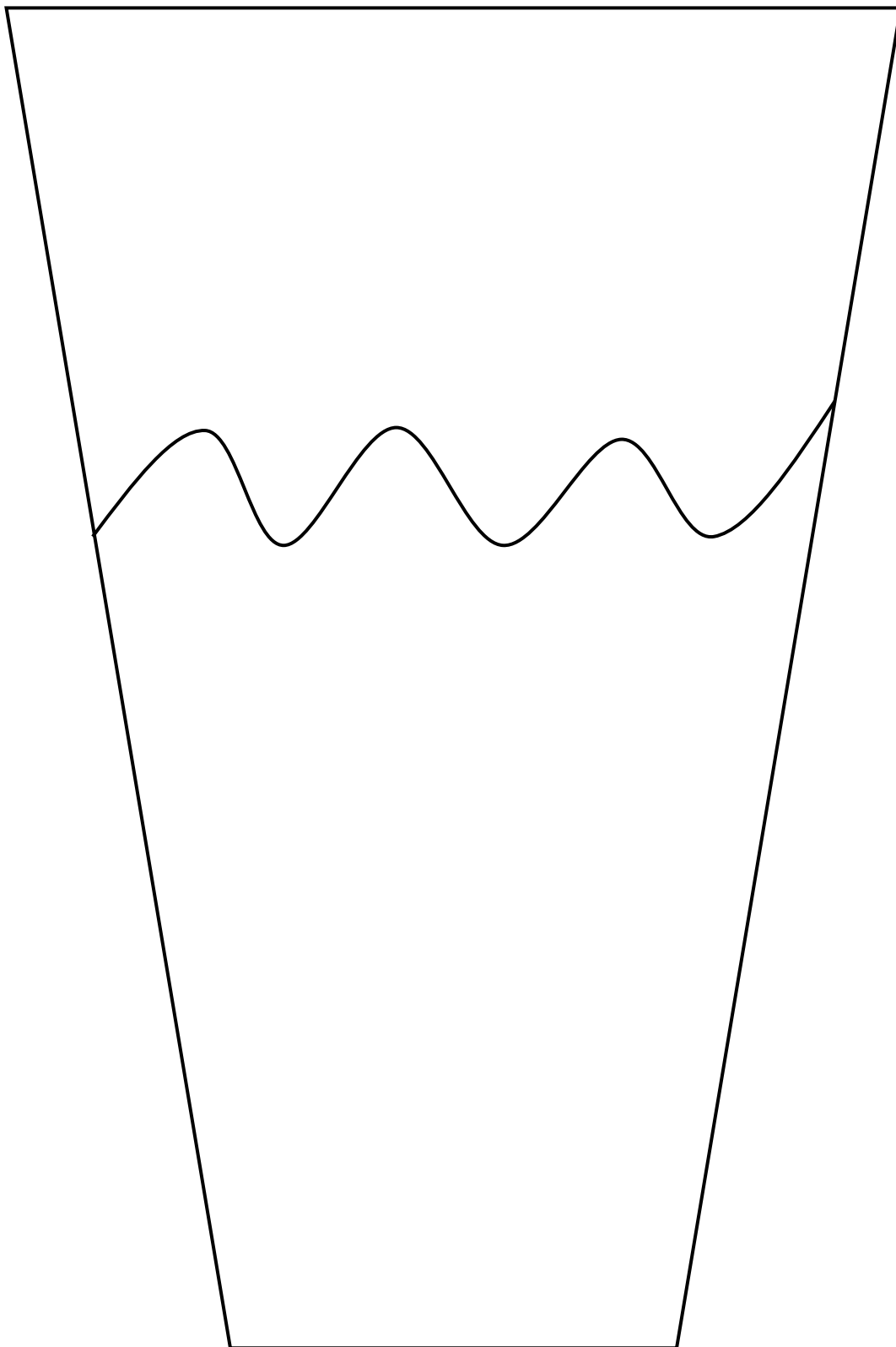

Rock

Duck

Seashell

Sand

(Water)

Bottle

Boat

Sponge

Float or Sink? Name: _____

Look at the list of different objects. If an object would float in water draw a picture of the object ABOVE the water line. If the object sinks, draw a picture of the object BELOW the water line.

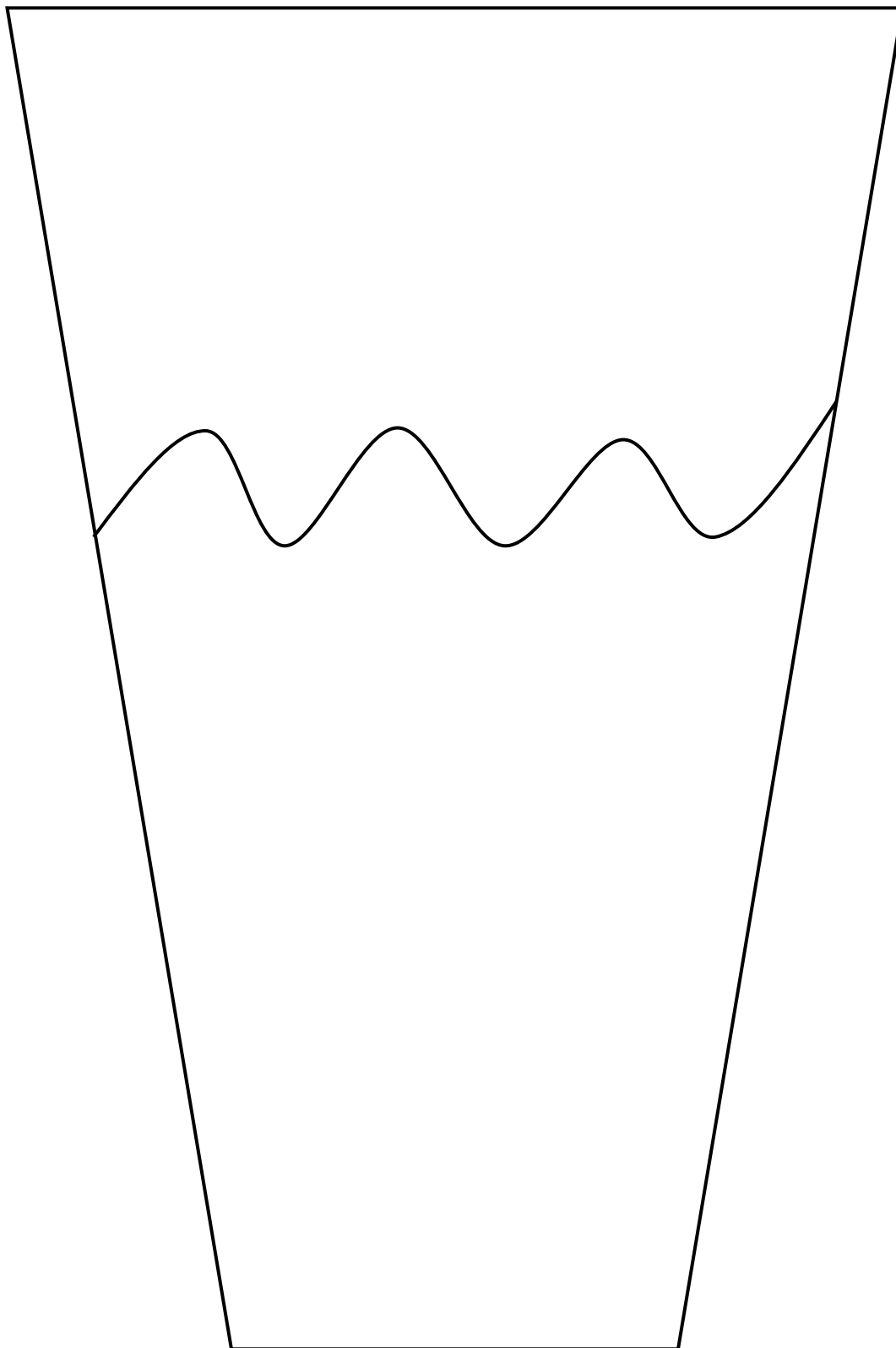

Rock
Duck
Seashell
Sand
(Water)
Bottle
Boat
Sponge

What do you know about Seahorses?

Write two things you know about the seahorse. Next, research facts about seahorses by reading books, visiting the library, searching the internet, etc. Write two things you learned about seahorses after your research.



What I know:	What I learned:
1.	1.
2.	2.

What do you know about Dolphins?

Write two things you know about Dolphins. Next, research facts about Dolphins by reading books, visiting the library, searching the internet, etc. Write two things you learned about Dolphins after your research.



What I know:	What I learned:
1.	1.
2.	2.



What do you know about Jellyfish?

Write two things you know about the Jellyfish. Next, research facts about Jellyfish by reading books, visiting the library, searching the internet, etc. Write two things you learned about Jellyfish after your research.

What I know:	What I learned:
1.	1.
2.	2.

What do you know about the Octopus?

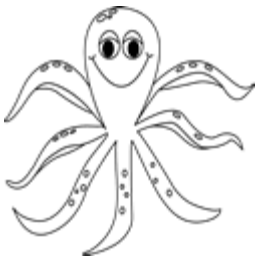

Write two things you know about the Octopus. Next, research facts about the Octopus by reading books, visiting the library, searching the internet, etc.

Write two things you learned about the Octopus after your research.

What I know:	What I learned:
1.	1.
2.	2.

My favorite ocean animal is the _____

because _____

A large, empty rounded rectangular box with a thin black border, intended for drawing or writing. It occupies the right half of the page.

I am scared of the _____ because _____

A large, empty rounded rectangular box with a thin black border, intended for drawing or writing. The corners are smoothly rounded.

Categorizing Animals Name: _____

Cut apart the pictures of the animals and glue them into the correct box. Do you find the animal in the water, on land, or in the air?

Water	Land	Air

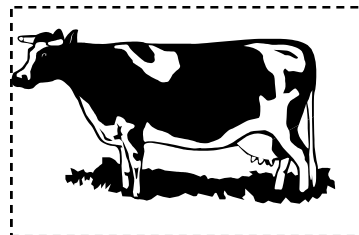
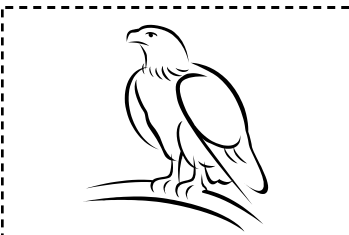
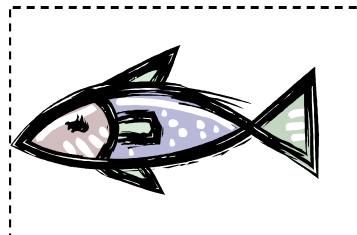
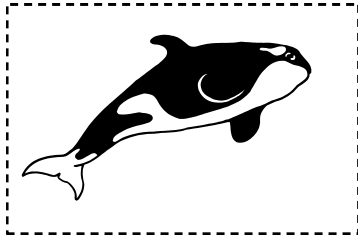
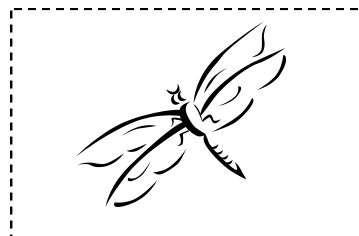
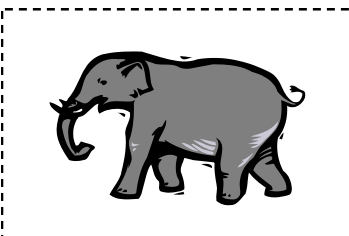
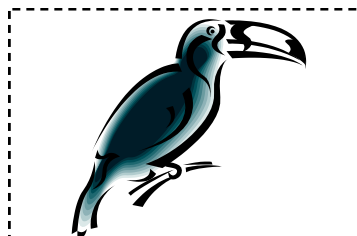
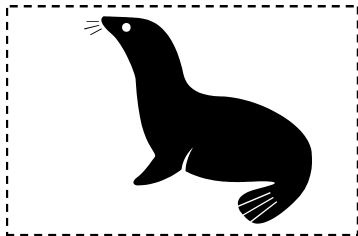

What I Love about Summer!

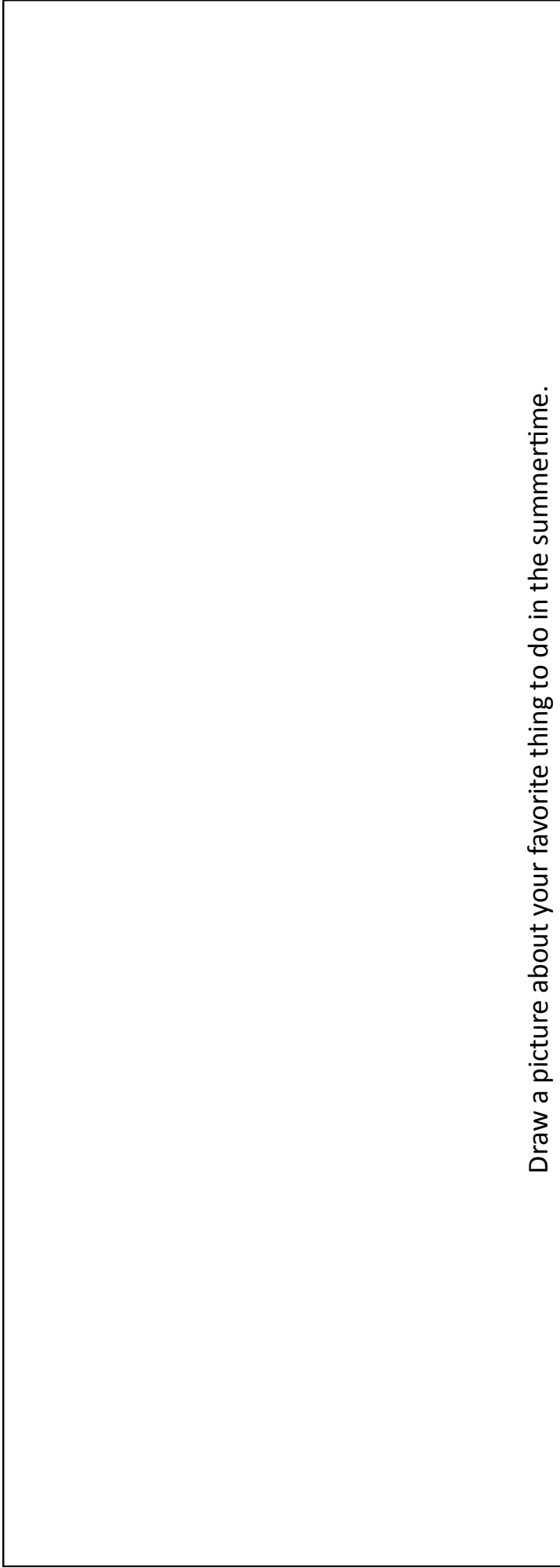

Draw a picture about your favorite thing to do in the summertime.

In the summer I can:

Taste: _____

Hear: _____

Smell: _____

Touch: _____

See: _____

Cut and Glue Shoes Name _____

Cut out the shoes and glue the correct number on the line.

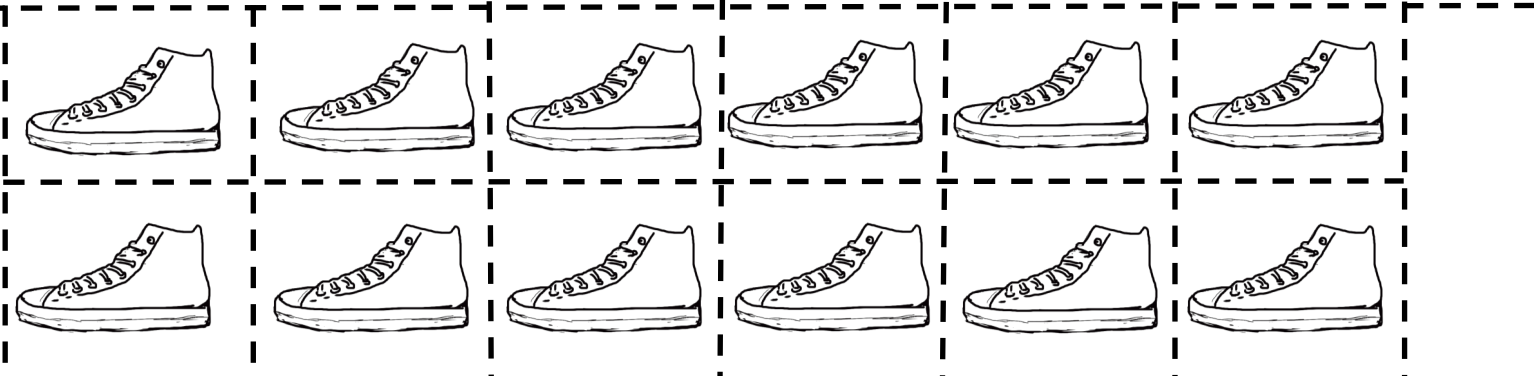

Cut and Glue Shoes Name _____

Cut out the shoes and glue the correct number on the line.

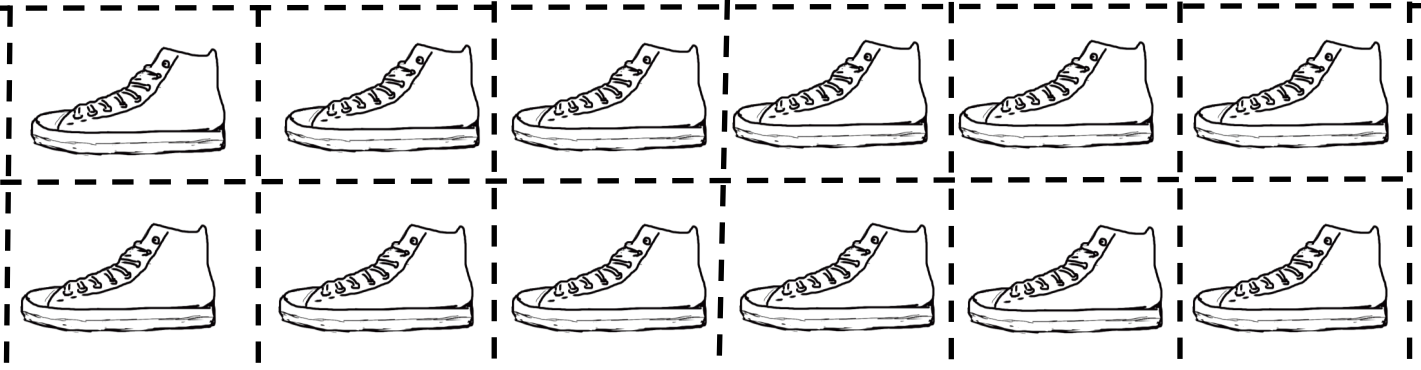

Domino Addition

Name: _____

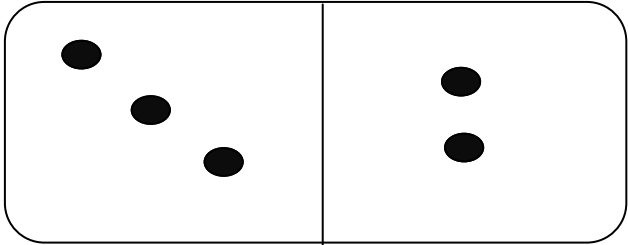
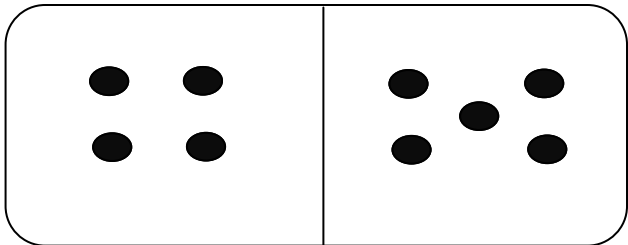
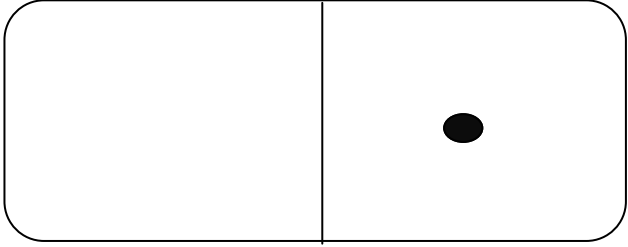
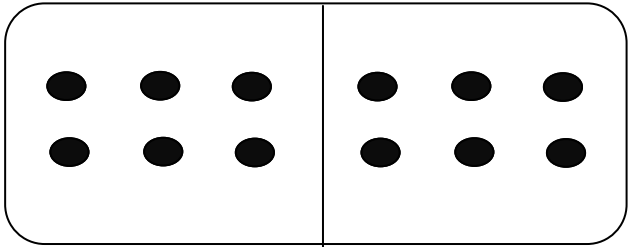
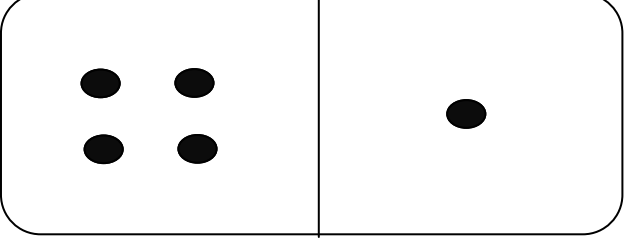
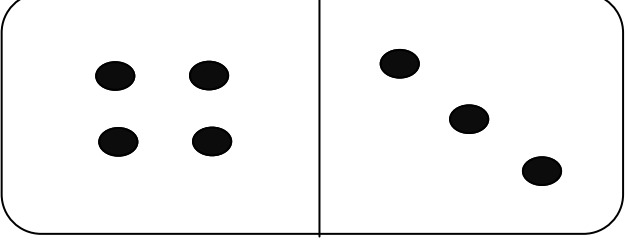
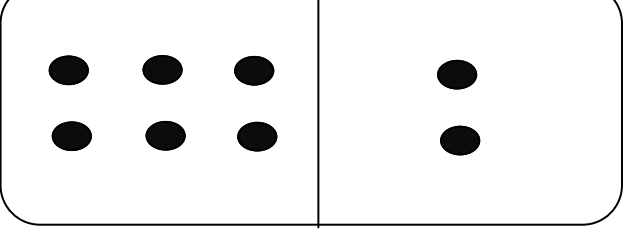
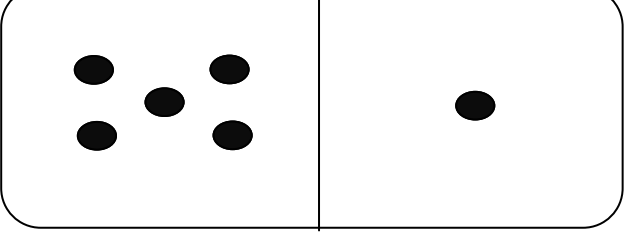
 ____ + ____ = ____	 ____ + ____ = ____
 ____ + ____ = ____	 ____ + ____ = ____
 ____ + ____ = ____	 ____ + ____ = ____
 ____ + ____ = ____	 ____ + ____ = ____

Number Writing Practice

Name: _____

Write your numbers 1-20

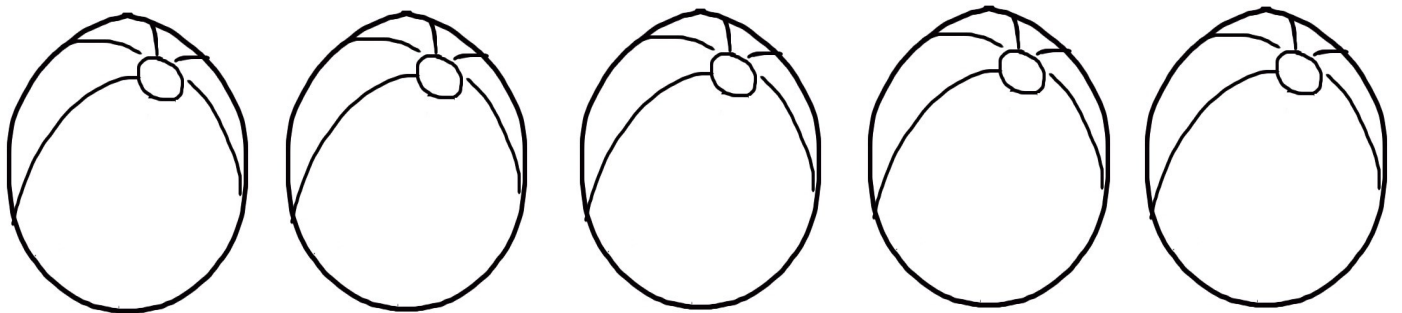
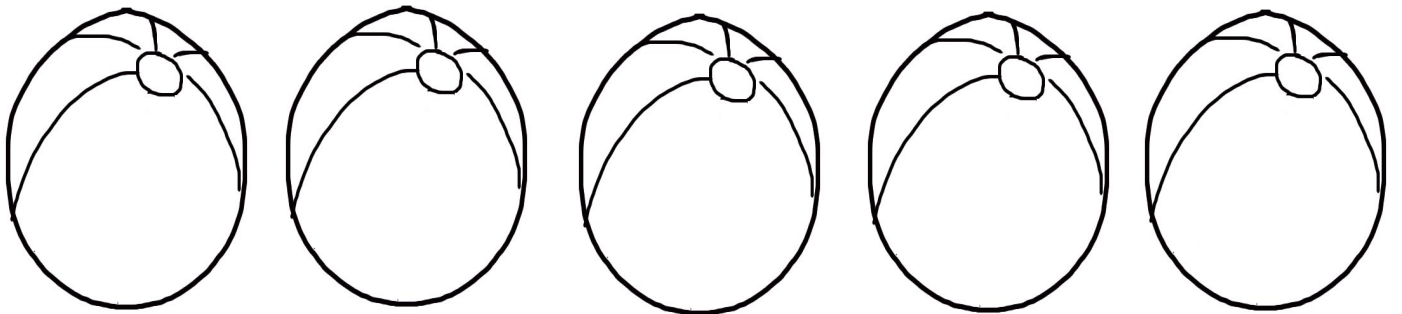
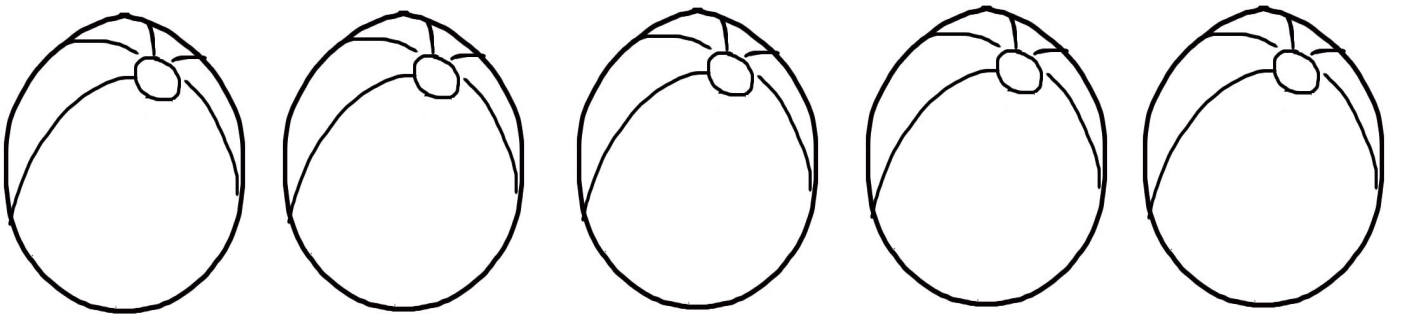
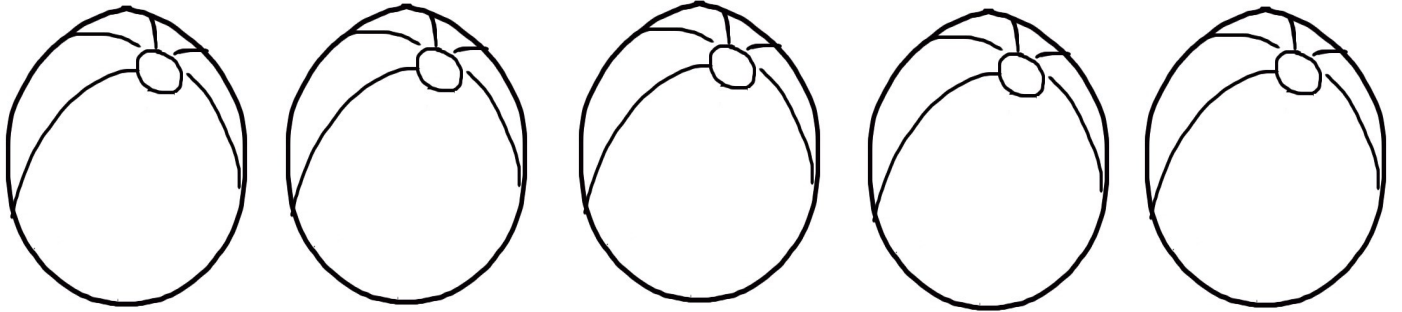

Skip Counting by 10's: Name: _____

Practice skip counting by 10's and write the numbers under Pete.

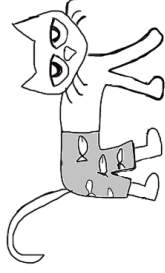
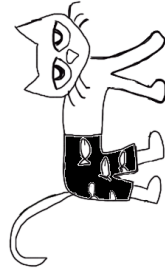
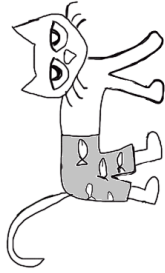
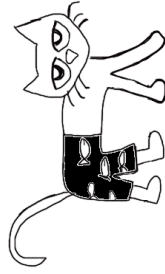
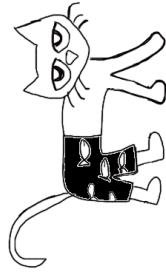
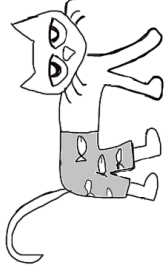
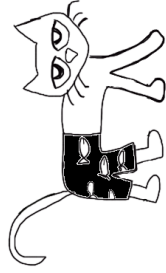
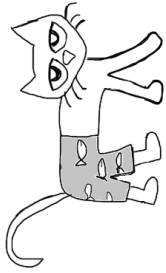

Skip Counting by 2's: Name: _____

Practice skip counting by 2's and write the numbers under Pete.

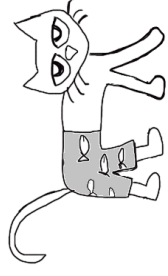
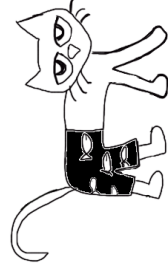
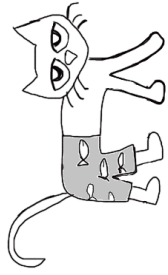
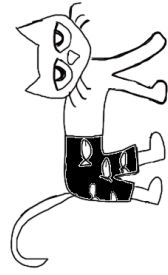
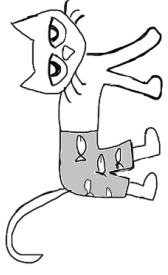
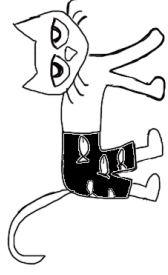
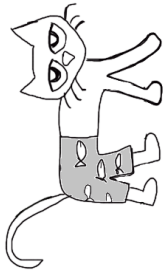

Skip Counting by 5's: Name: _____

Practice skip counting by 5's and write the numbers under Pete.

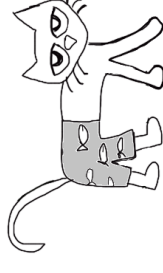
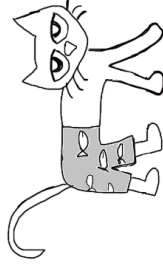
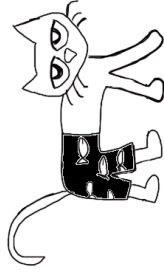
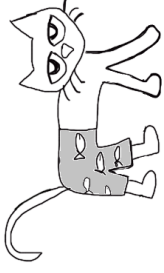
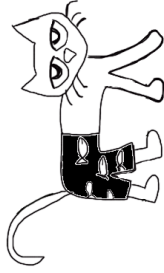
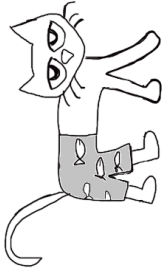

Skip Counting by _____ : Name: _____

Practice skip counting by _____ and write the numbers under Pete.

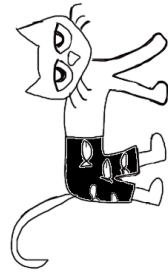
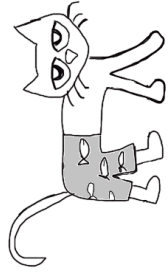
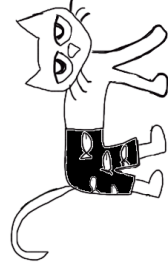
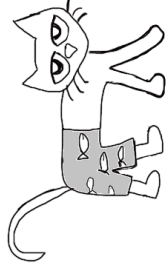
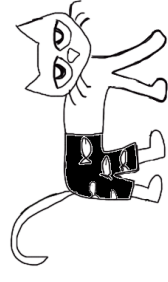
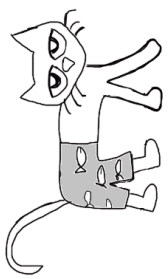
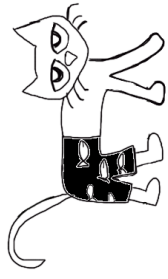
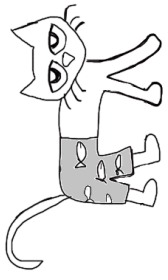

Odd Number Writing: Name: _____

Practice writing ODD numbers 1-19 by writing each number under Pete.

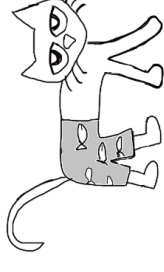
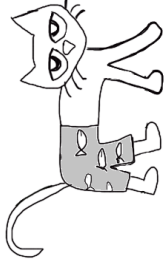
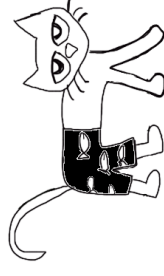
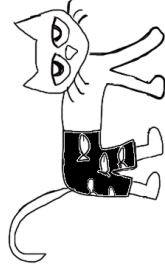
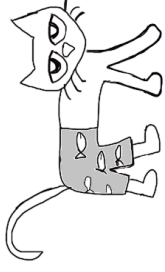
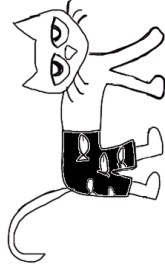
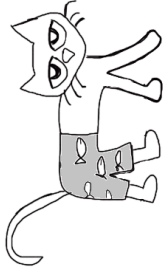
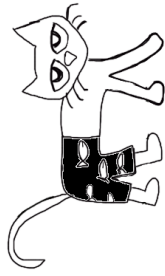

Odd Number Writing: Name: _____

Practice writing ODD numbers _____ by writing each number under Pete.

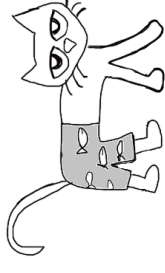
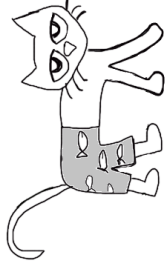
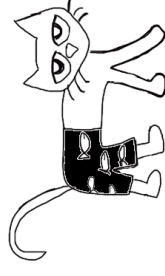
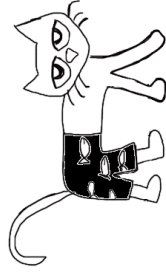
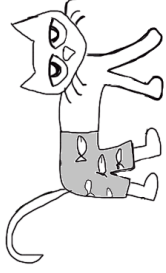
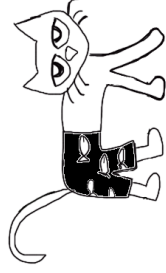
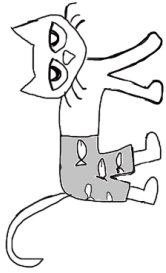
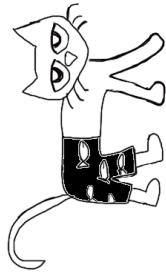

Even Number Writing: Name: _____

Practice writing EVEN numbers 2-20 by writing each number under Pete.

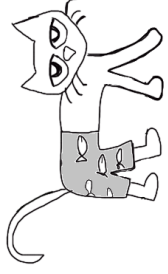
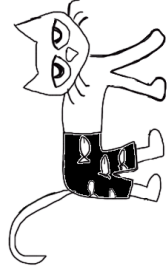
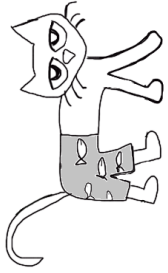
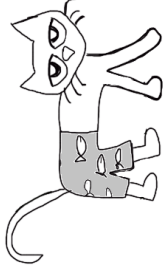
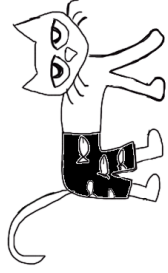
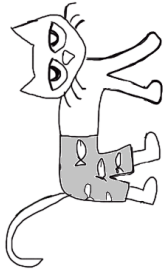
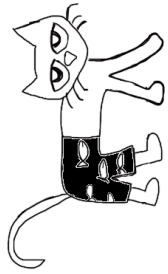

Even Number Writing: Name: _____

Practice writing EVEN numbers _____ by writing each number under Pete.

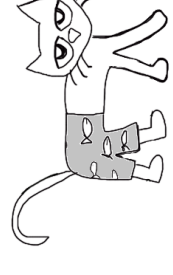
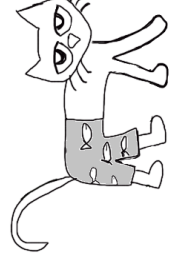
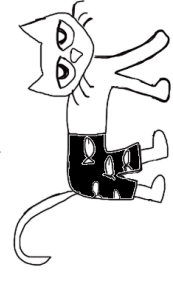
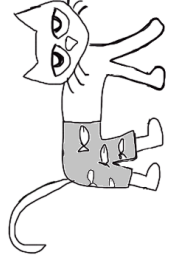
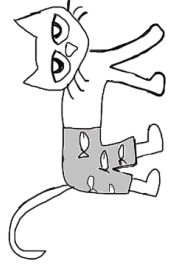

Name _____

Color the pattern of buttons for Pete.

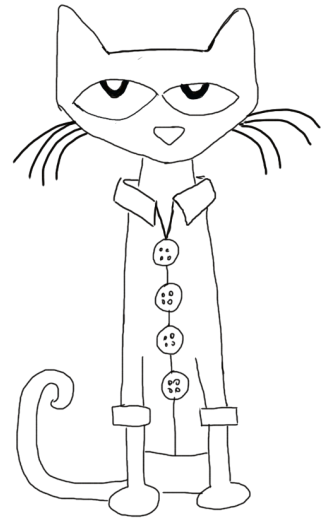

ABA pattern (two colors)

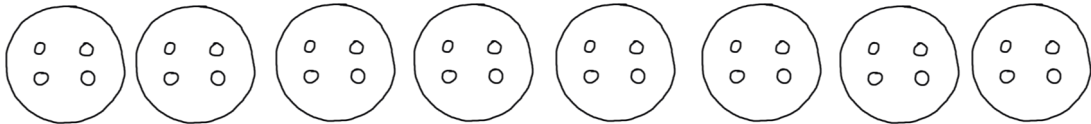

ABC pattern (three colors)



ABB pattern (two colors)



AABB pattern (two colors)

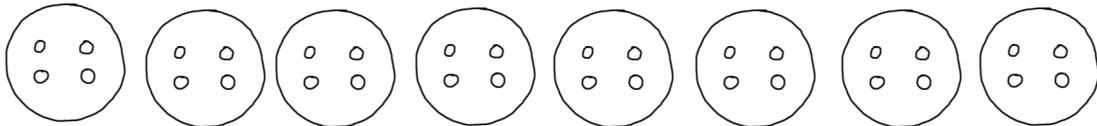
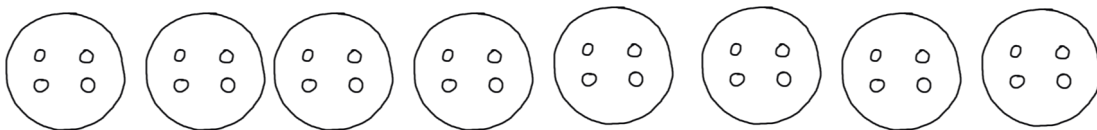
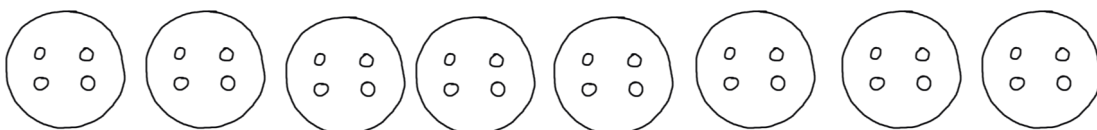

Race to Pete the Cat

Roll a numbered dice and fill in the graph after each roll.

Name _____

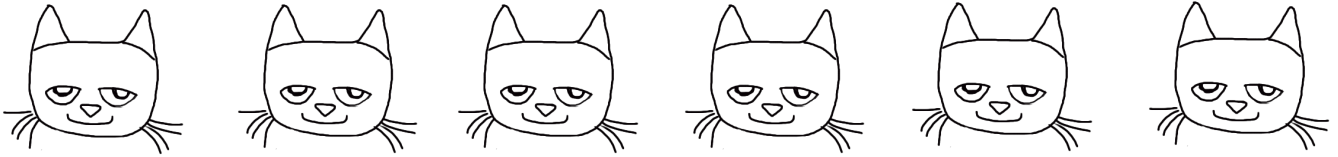

1 2 3 4 5 6

The # _____ had the most

The # _____ had the least

Which Number is Bigger? Name: _____

In each box, color the number that is larger.

1 2 3 4 5 6 7 8 9 10 11 12 13 14 15 16 17 18 19 20

1 4	15 16	7 5
20 14	11 12	8 10
13 9	6 17	2 3

I know the number 1

Trace the number:



Write the number:



Make the number using tally marks



Color in the 10 frame:

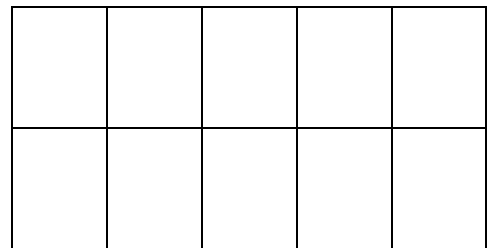

I know the number 2

Trace the number:



Write the number:



Make the number using tally marks



Color in the 10 frame:

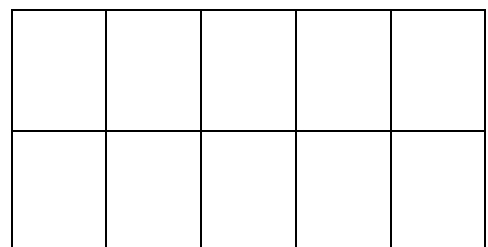

I know the number 3

Trace the number:

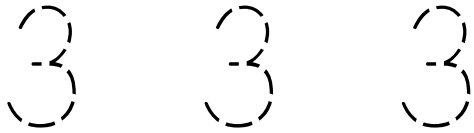

Write the number:

Make the number using tally marks

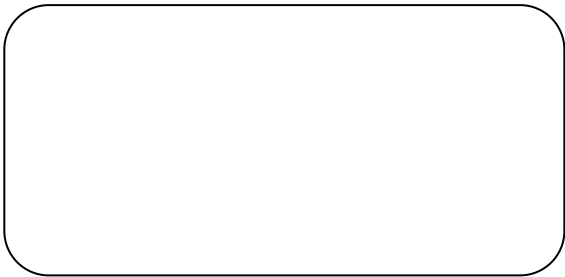

Color in the 10 frame:

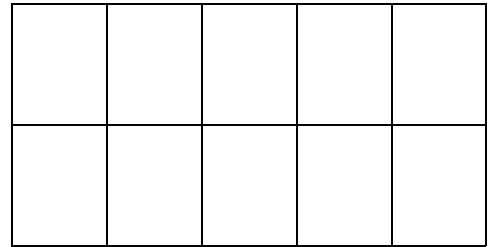

I know the number 4

Trace the number:

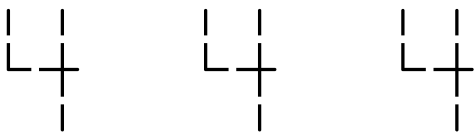

Write the number:

Make the number using tally marks



Color in the 10 frame:

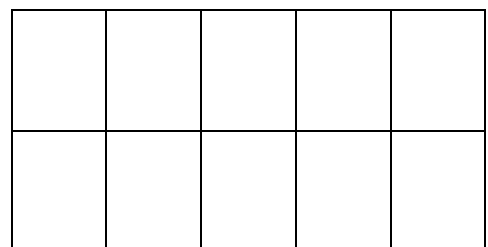

I know the number 5

Trace the number:

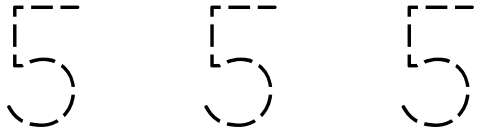

Write the number:

Make the number using tally marks

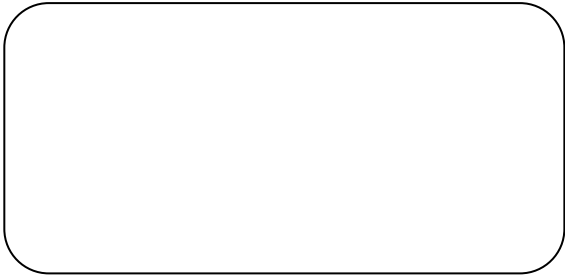

Color in the 10 frame:

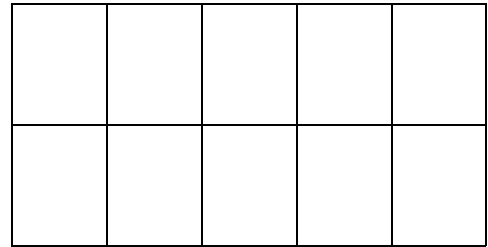

I know the number 6

Trace the number:

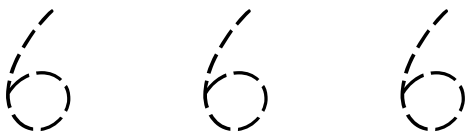

Write the number:

Make the number using tally marks



Color in the 10 frame:

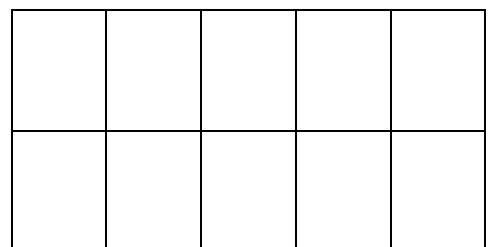

I know the number 7

Trace the number:



Write the number:

Make the number using tally marks

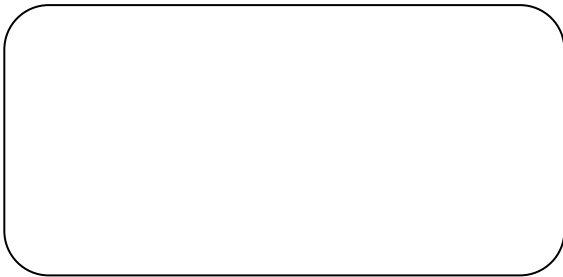

Color in the 10 frame:

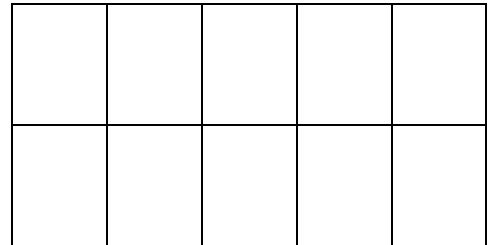

I know the number 8

Trace the number:

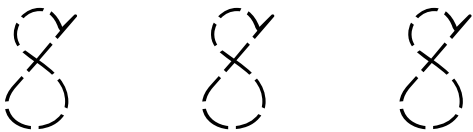

Write the number:

Make the number using tally marks



Color in the 10 frame:

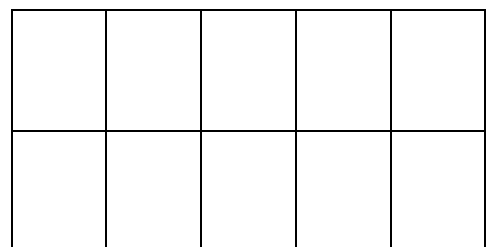

I know the number 9

Trace the number:

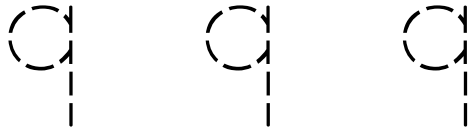

Write the number:

Make the number using tally marks

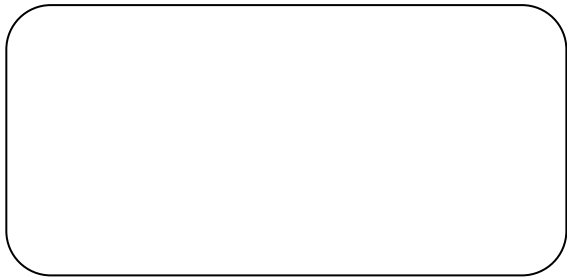

Color in the 10 frame:

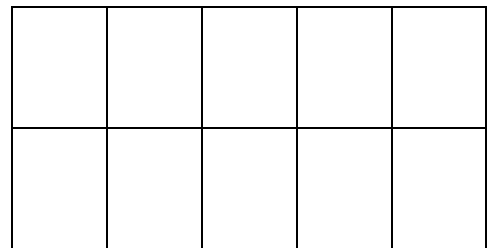

I know the number 10

Trace the number:



Write the number:

Make the number using tally marks



Color in the 10 frame:

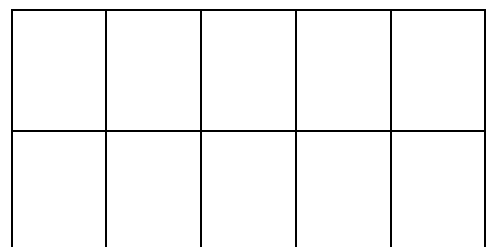

Tractor line up!

Name _____

Fill in the numbers that are missing.

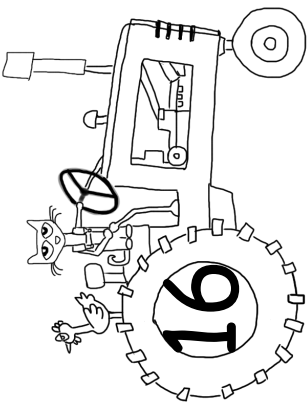
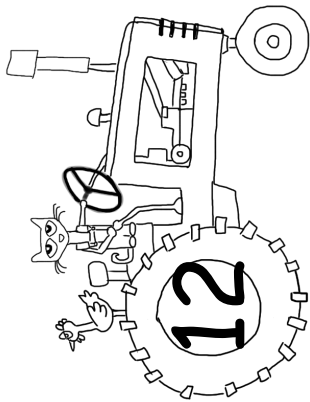
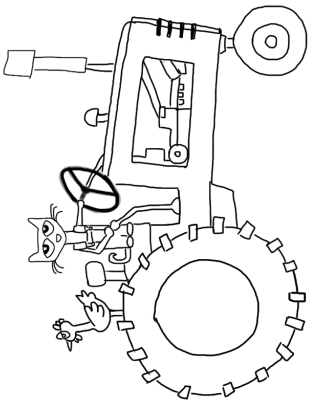
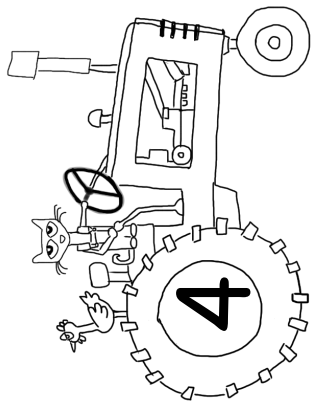
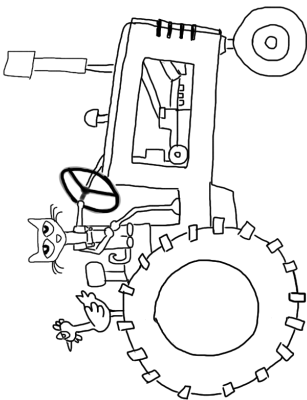
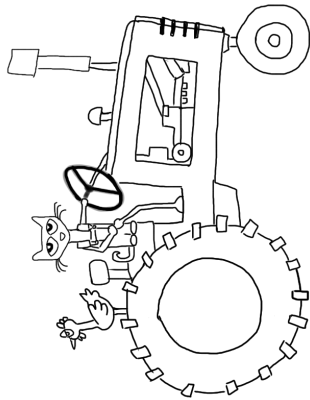
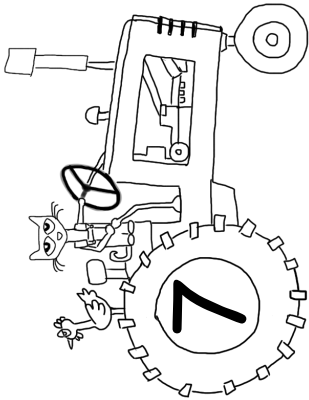
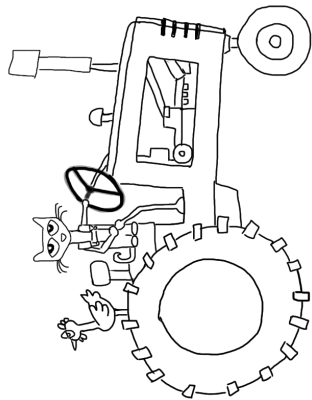
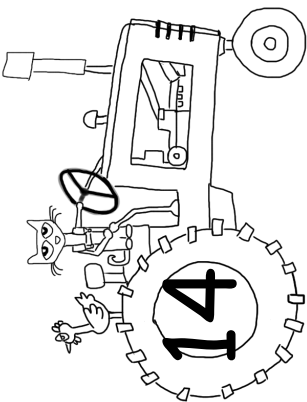
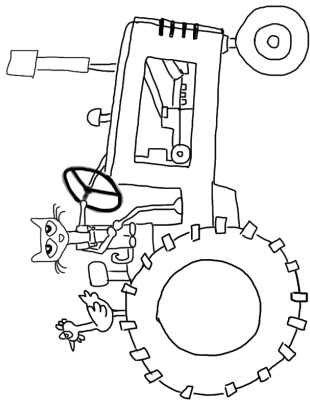
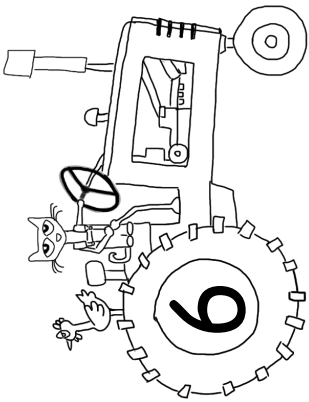
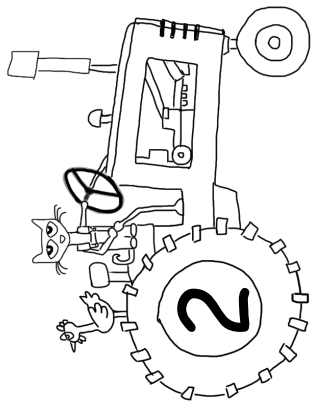
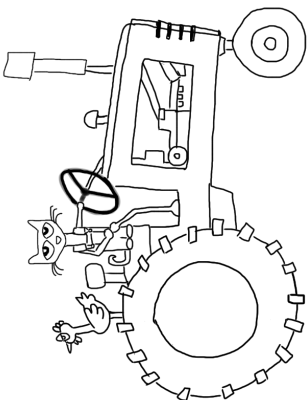
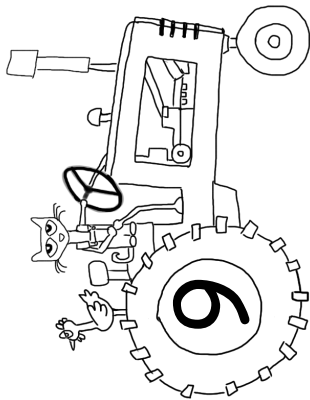
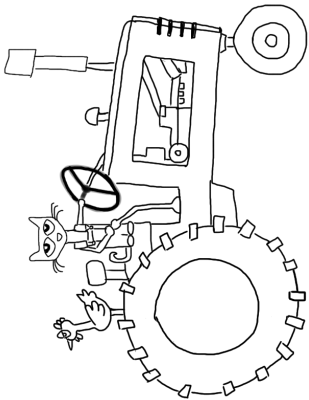
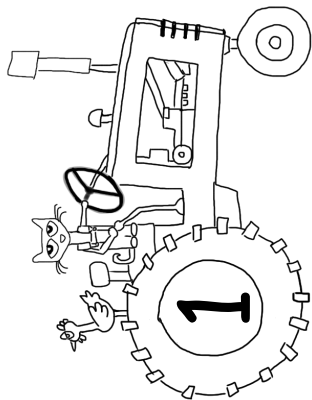

Tractor line up!

Name _____

Fill in the numbers that are missing.

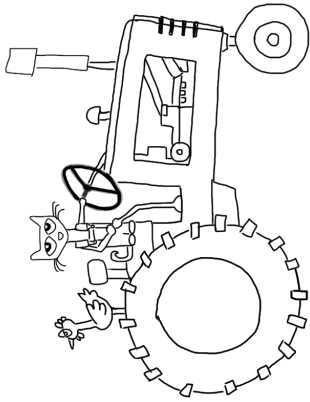
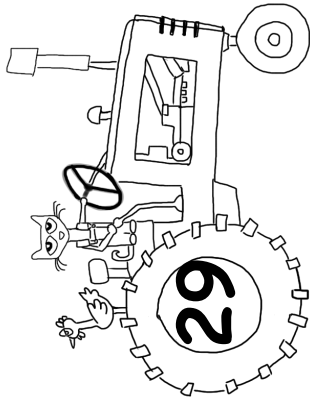
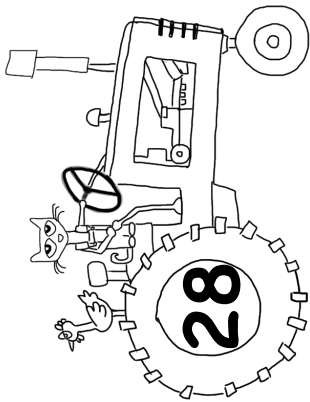
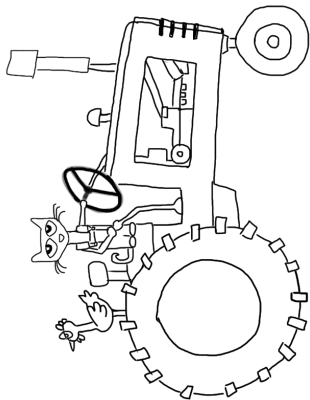
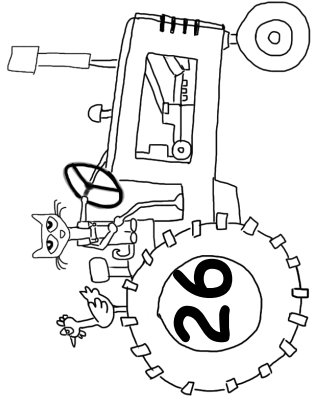
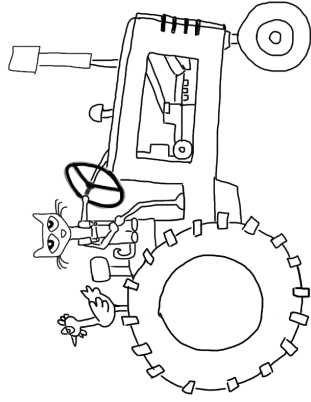
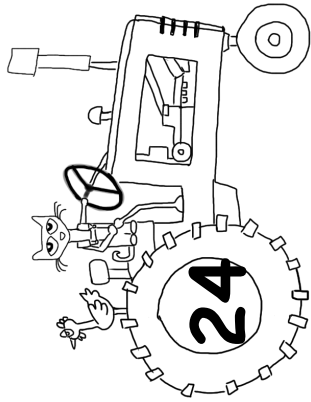
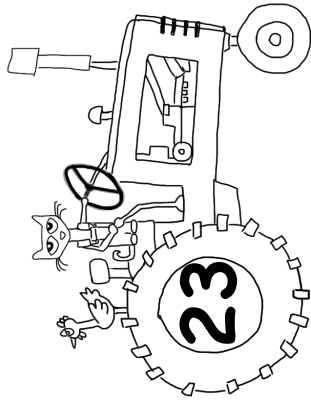
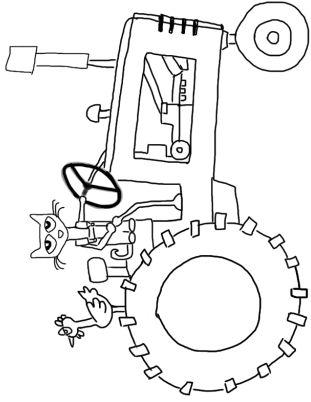
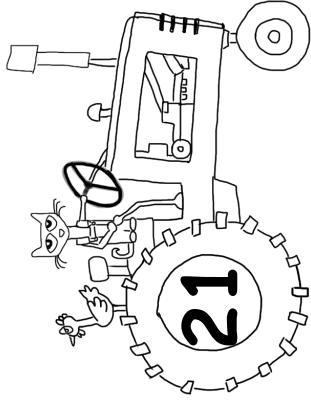
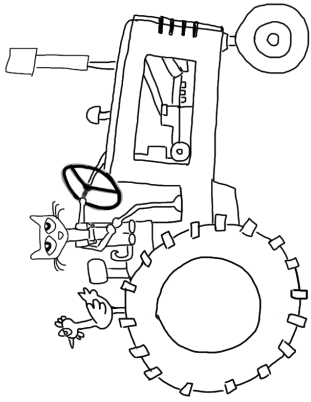
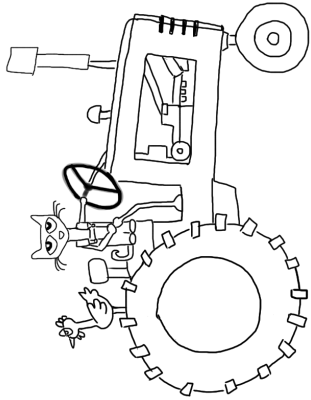
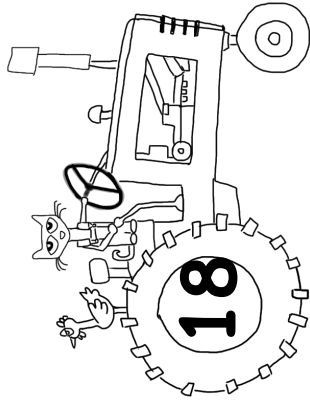
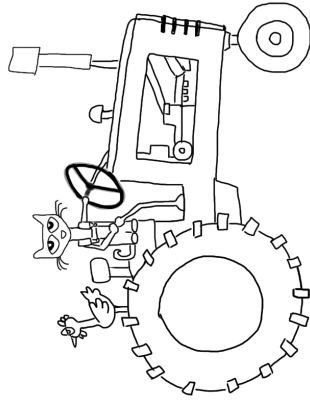
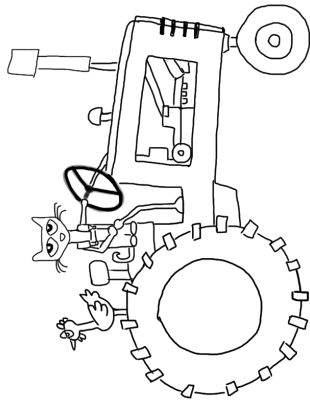
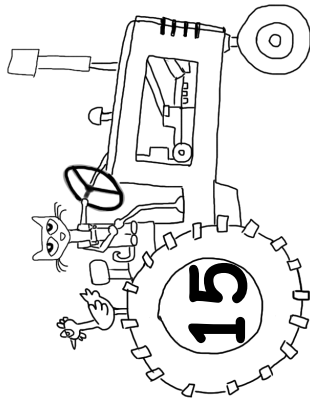

Name _____

Take me out to the ballgame!

Draw a line to the correct number of balls in the baseball diamond.

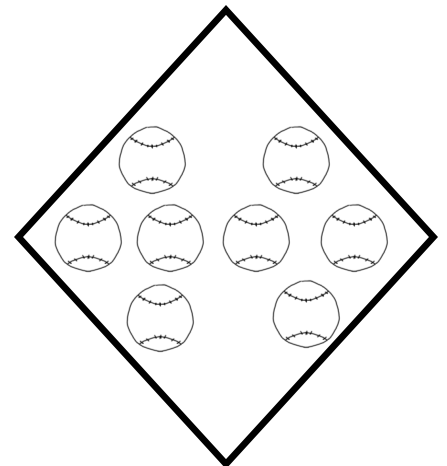
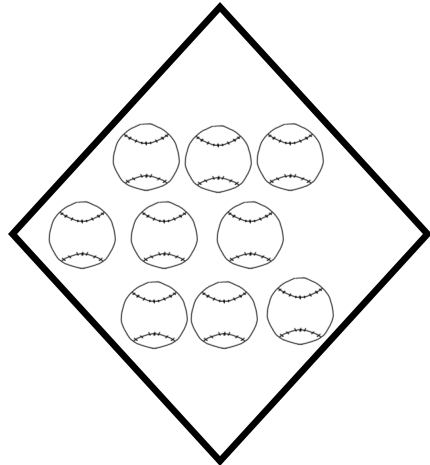
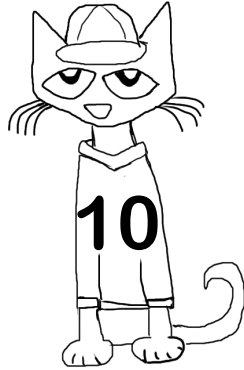
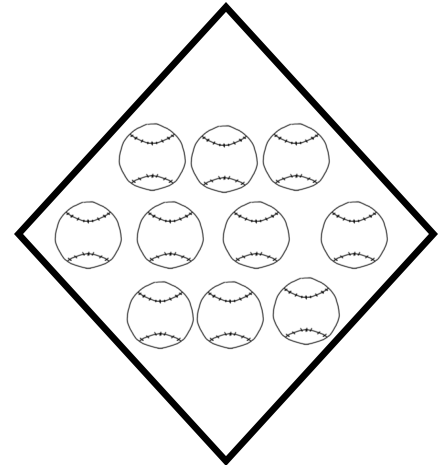
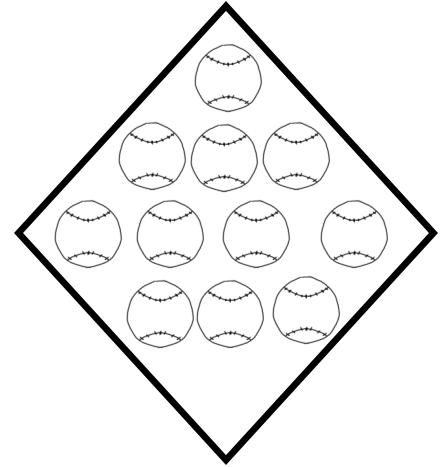
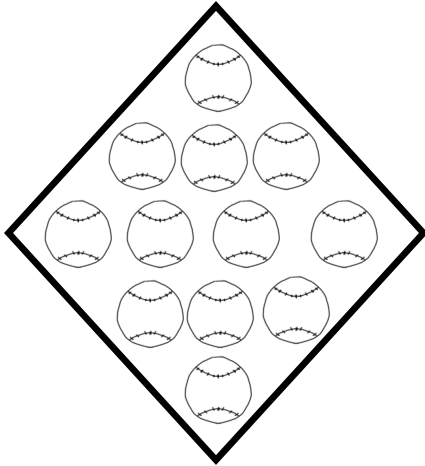

Take me out to the ballgame!

Draw a line to the correct number of balls in the baseball diamond.

Name _____

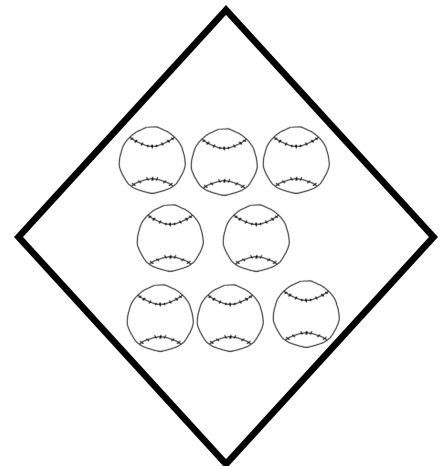
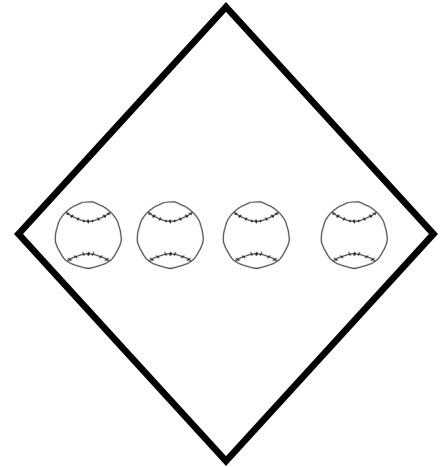
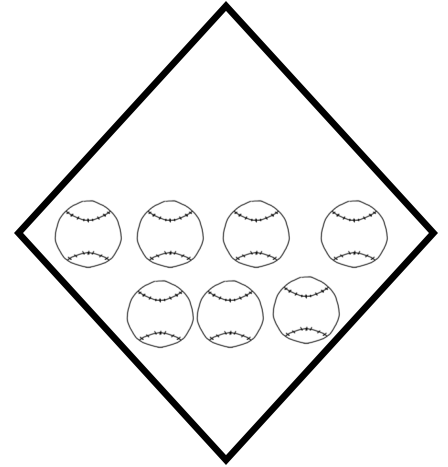
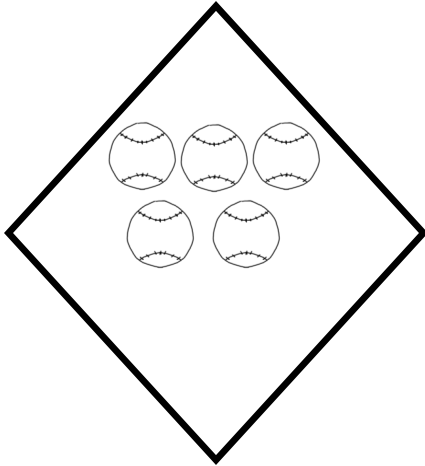

Take me out to the ballgame!

Draw a line to the correct number of balls in the baseball diamond.

Name _____

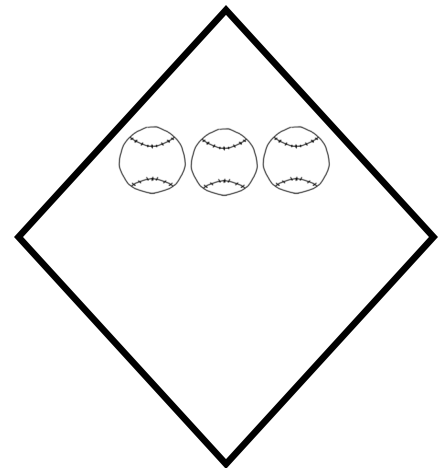
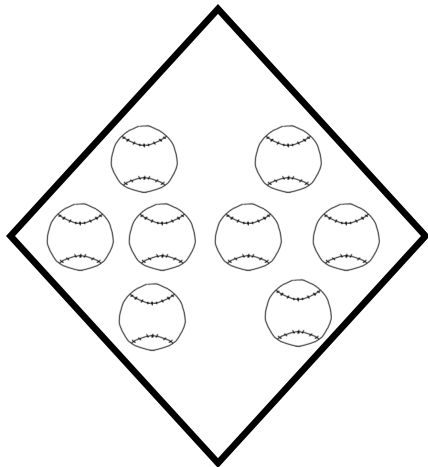
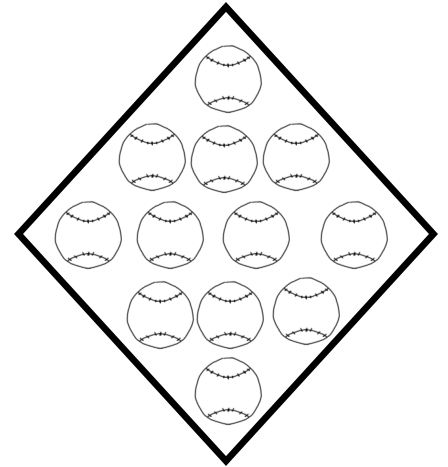
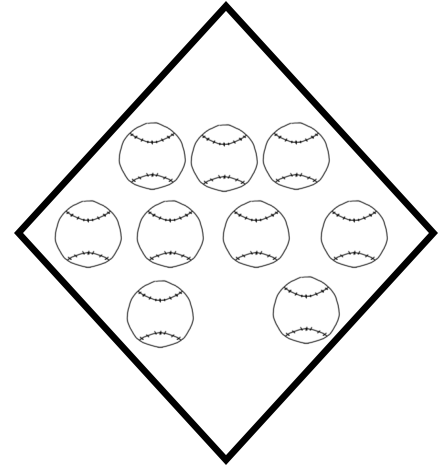
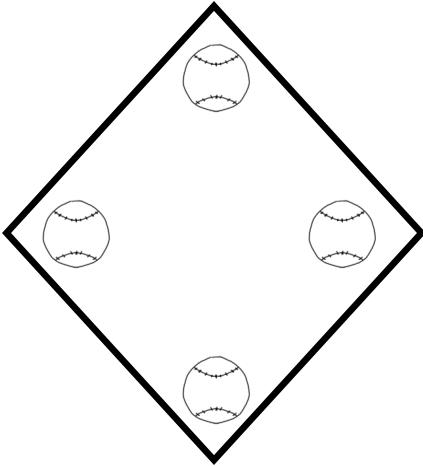

Scissor Skills Practice

Name _____

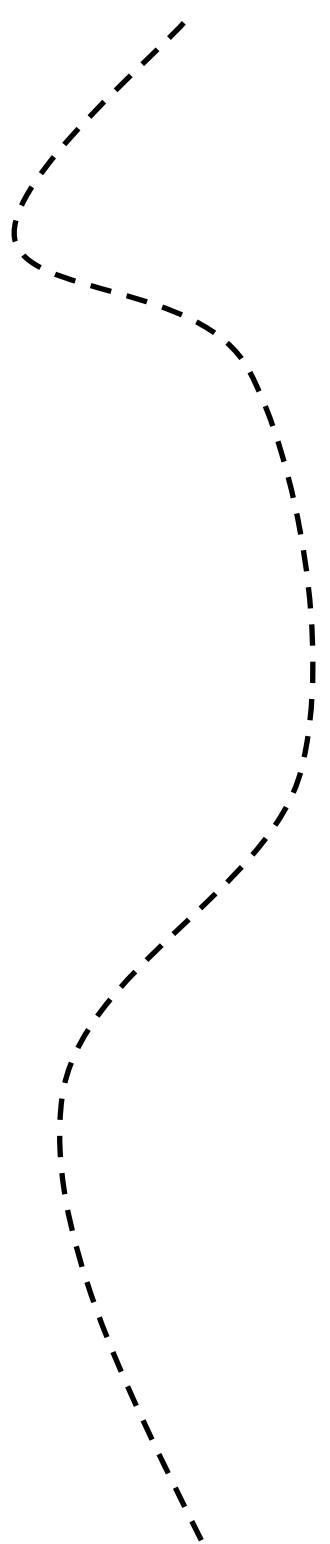
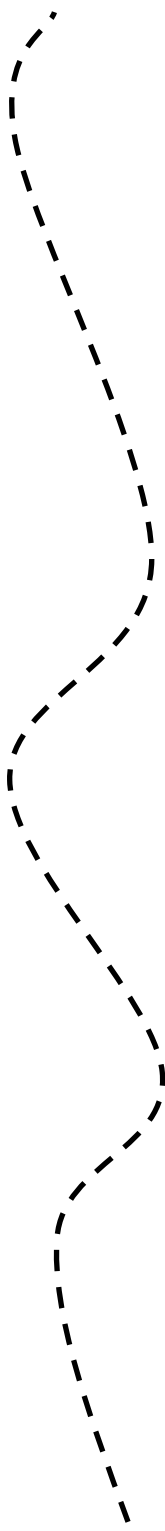
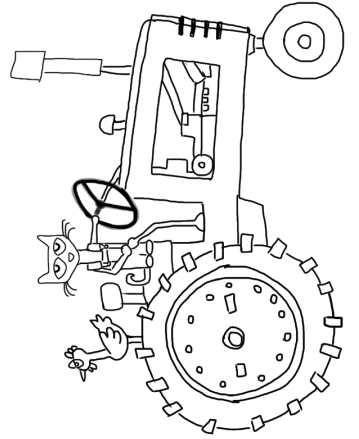
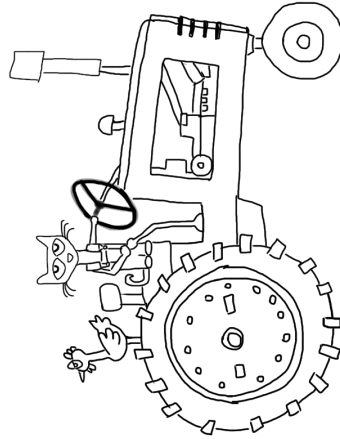
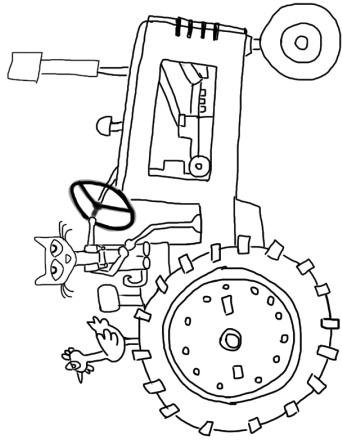

Scissor Skills Practice

Name _____

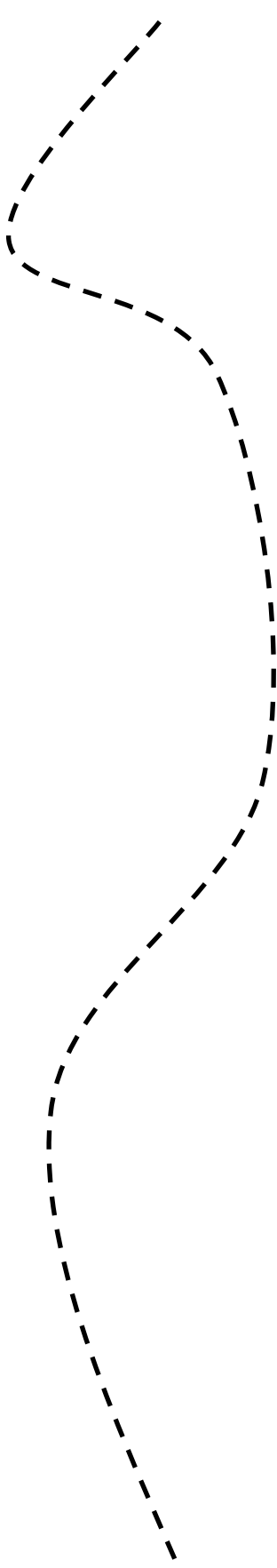
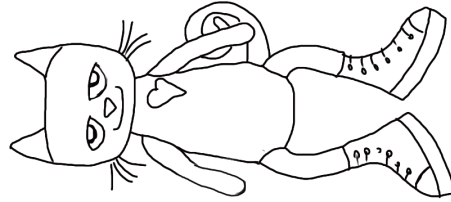
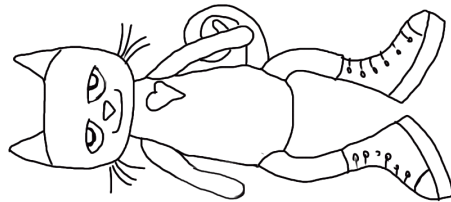
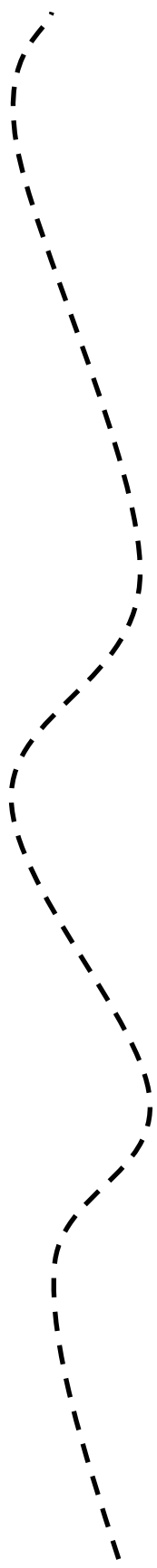
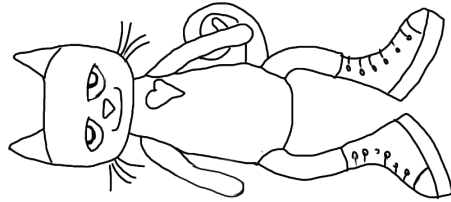

Scissor Skills Practice

Name _____

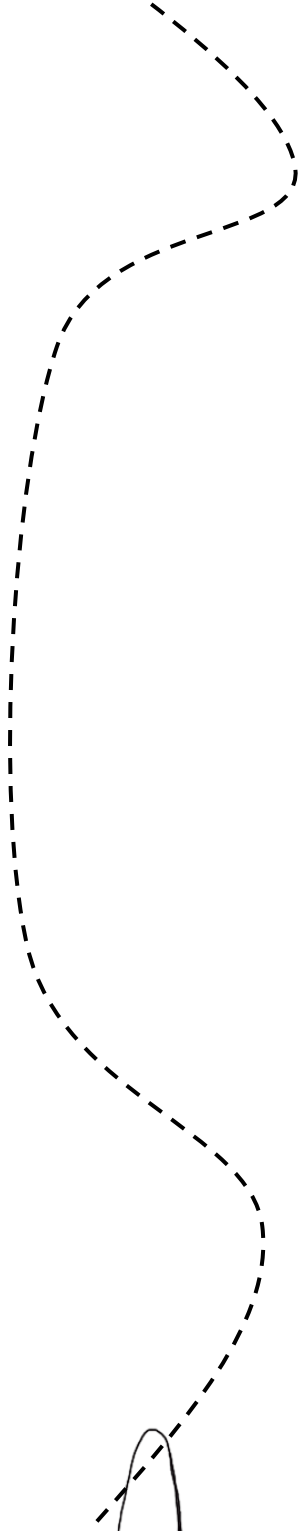
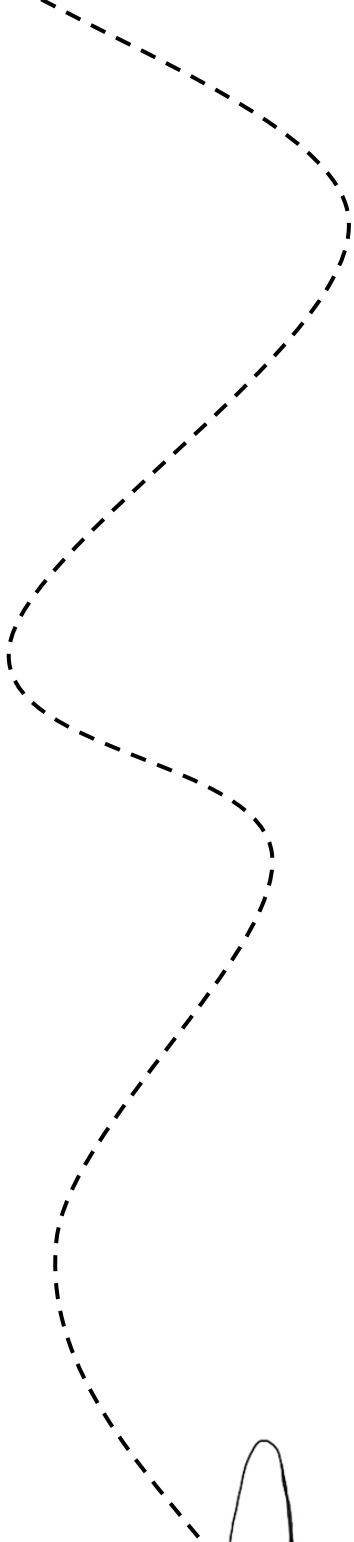
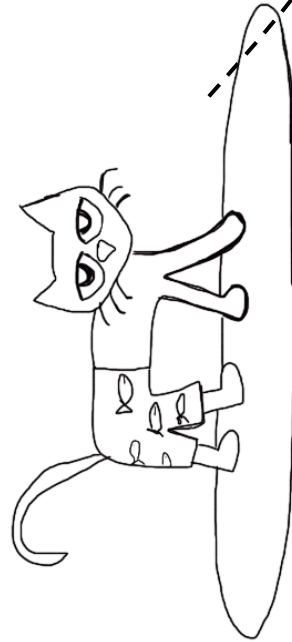
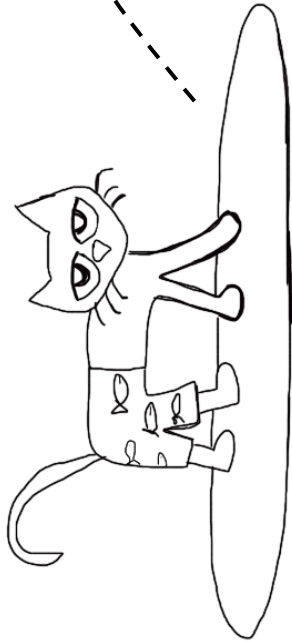
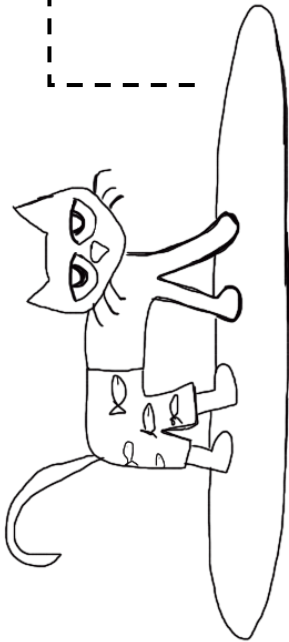

Picture Books



I CAN READ Books



[Links with more activities & free downloads](#)

<http://www.harpercollinschildrens.com/feature/petethecat/>

<http://www.ericlitwin.com/>

<http://www.pinterest.com/loraboyd/pete-the-cat/>

Thanks for downloading this product. We hope you find it useful and helpful in your classroom. Check out our other products at: <http://www.teacherspayteachers.com/Store/Team-Sugar>

This publication was created and is copyrighted by Team Sugar. All rights reserved. This product is bound by copyright laws. Redistributing, editing, selling, or posting this item (or any part thereof) is strictly prohibited.

The teacher/person who purchased this product may duplicate it for his/her personal use only. In addition, this unit may not be posted on the internet unless permission is granted by the author.

Graphics from: Team Sugar

WP Clipart: <http://www.wpclipart.com/>

My Cute Graphics: <http://www.mycutegraphics.com/>

CLKR.com: <http://www.clker.com/>