



AMERICAN OPTOMETRIC ASSOCIATION

# **Vision Therapy and Neuro-Rehabilitation: Optometric Considerations in Third Party Reimbursement**

Updated January 2020

# Vision Therapy and Neuro-Rehabilitation: Optometric Considerations in Third Party Reimbursement

Vision therapy and neurorehabilitation are used to treat specific diagnosed ocular, visual and visual perceptual conditions. In some cases, vision therapy is the only available and effective treatment option for those conditions. Treatment may be covered under major medical or vision insurance plans. An important consideration of managing a vision therapy practice is to appropriately code for all patients, whether using insurance or not.

## **Reimbursement of vision therapy**

This information packet has been developed to assist individuals involved with medical insurance claims processing and review to better understand the application and utilization of optometric vision therapy. Although vision therapy is not a new area of medical care, information gained from scientific research and clinical application of vision therapy has been expanding in recent years.

Vision therapy has been shown to be an effective treatment modality for many types of problems affecting the vision system. Vision therapy services include the diagnosis, treatment and management of disorders and dysfunctions of the vision system including, but not limited to, conditions involving binocularity, accommodation, oculomotor disorders and visual perceptual-motor dysfunctions. However, the exact length and nature of the therapy program can vary with the specific complexity of the diagnosed condition.

This packet contains fact sheets regarding the treatment and management of various conditions utilizing optometric vision therapy. Because of the differences in complexity of conditions and management approaches, this information should be used only as a framework. Ultimate responsibility for the correct submission of claims and responses to any remittance advice lies with the provider of services.



## **Coding background**

Understanding which codes doctors of optometry should use and their respective definitions is most important in all coding. The entire coding and medical industries are dependent upon accurate code use and interpretation to allow information to be accurately transferred between the provider and the payer. Codes used by optometrists are also used by general medicine and/or other specialty providers. Coding and billing in an optometric office is performed using code sets established and maintained by different entities. The code sets used in this process include: the ICD-10 Clinical Modification code set, the Current Procedural Terminology code set—which is usually called CPT®, and the Health Care Common Procedural Coding System or HCPCS code set. Each code set has a specific purpose in the billing process.

The standard code sets used in optometric practices have specific purposes. They consist of the ICD-10 CM codes for diagnoses, the CPT codes for most procedures and the HCPCS Level II codes for procedures and products not covered under the CPT umbrella. Most carriers have published policies that follow the CPT closely, although it's not uncommon to find that they may have specific policies or guidelines that build on the CPT definition for a particular code. At the current time, ICD-10 CM is developed to allow for greater classification of morbidity and mortality within diagnoses for physicians.

All of these code sets are standardized nationally. The Health Insurance Portability and Accountability Act (HIPAA) prohibits the use of proprietary codes that were previously developed and used by local carriers, insurers and provider groups. It also stipulates that all codes are to be used as they are defined and not to report additional services that are not currently included in the definition.

Medicare contractors and third-party insurance companies have policies regarding coverage decisions about which items or services are reasonable and necessary. Often they elaborate on procedural codes rather than simply relying on the CPT definition. These policies are generally available on the carrier's website or in the provider manual and are referred to in current nomenclature as Local Coverage Determinations (LCDs) by Centers for Medicare and Medicaid Services (CMS) or clinical policy bulletins, medical coverage policy and medical coverage determinations by the major national third-party payers. Regardless of which acronym or name used, they serve the same function by defining the appropriate guidelines in using a particular code.

Delivering quality health care depends on capturing accurate and timely medical data. Medical coding professionals fulfill this need as key players in the health care workplace.

Health information coding is the transformation of verbal descriptions of diseases, injuries and procedures into numeric or alphanumeric designations. Originally, medical coding was performed to classify mortality (cause of death) data on death certificates. However, coding is also used to classify morbidity and procedural data. The coding of health-related data permits access to medical records by diagnoses and procedures for use in clinical care, research and education.

There are many demands for accurately coded data from the medical record. In addition to their use on claims for reimbursement, codes are included on data sets used to evaluate the processes and outcomes of health care. Coded data are also used internally by institutions for quality management activities, case-mix management, planning, marketing and other administrative and research activities.

∞

### **Which codes could I use?**

There are a finite number of codes you will use in the vision therapy portion of your practice. These codes can be subdivided into: examination procedure codes, diagnostic codes, and therapeutic procedure codes. In all of the code choices, the most important factor is documentation. If you have the documentation needed to support the history, examination, treatment plan and medical decision-making requirements, you may have several codes to choose between.

The primary rule of documentation is, "if it wasn't documented, it never happened." In the instance where the work has been performed and properly documented, you can choose procedure codes based on what is covered, what is permitted, and/or what reimburses appropriately for your time. One should not search for the highest reimbursing code, because often the higher reimbursement requires additional non-patient care work including multiple written reports and requires a significant amount of additional staff time. Often, the end result after factoring in all these costs may be a lowered net reimbursement.

Coding is a complex topic for all health care providers, including doctors of optometry. It is strongly suggested that you utilize all resources available when you code for insurance filing. This document is intended only as an introduction to the topic. The key to coding is to have your chart completely support the codes that you used according to the definitions listed by CPT. If you choose to accept insurance in

your vision therapy practice, knowledge of your local carriers and their particular requirements is critical to success. Once you have that knowledge, use it to create a consistent, solid pattern of documentation in your records and assume that every time you document, an auditor will see what you have written.



### **Which examination procedure codes could I use?**

The American Medical Association owns the CPT codes. There are several evaluation and management procedural codes that could be used for an office visit to determine if the patient has an ocular, visual or visual perceptual problem. They include 92002, 92004, 92012, 92014, 99201-99205, or 99211-99215. These codes are defined as comprehensive general ophthalmologic examination codes (92004 and 92014), intermediate general ophthalmologic examination codes (92002 and 92012) and the evaluation and management codes (99201-99205 and 99211-99215). You can use these codes in multiple combinations on different days if it best describes the procedures you are performing. For example, a new patient seen in the office today for a 92004 (comprehensive general ophthalmologic examination-new patient), tomorrow for a 92012 (intermediate general ophthalmologic examination-established patient) and next week for a 99213 (evaluation and management exam of an established patient) visit. According to Correct Coding Guidelines, it would be incorrect coding to use these procedure codes simultaneously on the same day.

Other procedure codes to consider are consultation codes. A consultation is a type of service provided by a physician whose opinion or advice regarding evaluation and/or management of a specific problem is requested by another physician or other appropriate source. These are the 99241-99245 codes. Usually, these codes are only to be used on the patient's first visit to the office after a physician or other appropriate professional made the referral. Occasionally, the consultation codes can be used for established patients when there was a request for new information from the referring doctor. Consultation codes must have documentation that includes correspondence from the doctor requesting the consultation. While Medicare discontinued reimbursement for consultations in 2009, there are still medical plans that do reimburse for consultations.

If the patient is coming to you for a consultation initiated by a patient and/or family member, and not requested by a physician, you should use the evaluation and management codes 99201-99205.



### **Which special testing codes could I use?**

There are several coding options for patients who require additional testing: 92060 (sensorimotor exam) for motor alignment and function and 96110 (developmental testing; limited), 96112/96113 (developmental testing), and 96116/96121 (neurobehavioral status exam) for visual processing assessment. These codes can be used in combination with evaluation and management codes, by themselves or with each other to best describe the procedures you are doing.

### **What is a sensorimotor exam?**

A basic sensorimotor exam evaluates ocular range of motion to determine if the eyes move together in the various cardinal positions of gaze (12:00, 3:00, 9:00, etc.). This exam element is commonly noted as ocular motility, or extraocular muscles (EOM), in the chart note. A normal range of motion is often noted as "full" or "within normal limits."

CPT lists basic sensorimotor exam as a required exam element of a comprehensive eye exam (920×4); it is an incidental component and not separately reimbursed. A quantitative sensorimotor examination, utilizing prisms to measure ocular deviation, is a more extensive exam and may be separately billable.

Unlike a basic sensorimotor exam, CPT describes the diagnostic test 92060, as sensorimotor examination with multiple measurements of ocular deviation (e.g., restrictive or paretic muscle with diplopia) with interpretation and report (separate procedure). Fundamentally, this test requires the clinician to assess both eyes (and is therefore bilateral); it should not be billed per eye. Pertinent diagnoses include but are not limited to: diplopia, exotropia, esotropia, hypertropia and paralytic strabismus.

The American Association for Pediatric Ophthalmology and Strabismus (AAPOS) issued a position statement in 1999. They state, "Sensorimotor eye exam includes measurement of ocular alignment in more than one field of gaze at distance and/or near, and inclusion of at least one appropriate sensory test in patients who are able to respond." Measuring only primary gaze at distance would not satisfy the requirements. You should include ocular alignment measurements in more than one field of gaze. Primary gaze at distance and near for accommodative esotropia would satisfy the criteria.

Examples of sensory function testing include Worth 4 dot, Maddox rod, and Bagolini lenses. The assessment of sensory function is complementary to the evaluation of the motor function as the term "sensorimotor" implies. It is no less important and is an essential part of the service.



#### **How is the sensorimotor exam documented in the patient's medical record?**

An order for the test should be noted in the chart. Test results for motor function are typically documented in a "tic-tac-toe" format to represent different fields of gaze. Results of the sensory function test are noted, too. Examiners should note which stereopsis test is used and the scored findings (not just pass or fail). Results of a Worth 4 dot often note which lights were seen. An interpretation of the test results and the effect on the patient's condition and course of treatment satisfy the interpretation requirements. Take care that the notations for the test are clearly identifiable and distinct from the office visit notes (e.g., stamp, boxed entry, separate page, etc.).

Repeated testing is indicated when medically necessary for new symptoms, disease progression, new findings, unreliable prior results or a change in the treatment plan. In general, additional testing is warranted when the information garnered from the eye examination is insufficient to adequately assess the patient's disease. For example, if a patient has a history of accommodative esotropia and the basic sensorimotor exam reveals an unstable or worsening condition, the more extensive test is justified. Insurance carriers would not expect a claim for a stable patient who presents with no complaints or one with a controlled condition.

#### **What are cognitive/developmental function tests?**

The specific 96000 CPT codes used by physicians are used to report the services provided during testing of the cognitive function of the central nervous system. The testing of cognitive processes, visual motor responses, and abstract abilities is accomplished by the combination of several types of testing procedures. It is expected that the administration of these tests will generate material that will be formulated into a report.

A physician of any specialty can report these services. The use of developmental screening instruments of a limited nature (e.g., Developmental Screening Test II, Early Language Milestone Screen, Parents'

Evaluation of Developmental Status, Ages and Stages, and Vanderbilt attention-deficit/ hyperactivity disorder rating scales) is reported using CPT code 96110, developmental testing; limited. Code 96110 is often reported when performed in the context of preventive medicine services, but may also be reported when screening is performed with other E/M services such as acute illness or follow-up office visits. An office nurse or other trained non-physician personnel performs this service; this code does not include any physician work. The review of the screening results is included in the preventive or E/M service. Questions asked by a physician about a child's development, as part of the general history is not a formal measure as such *and is not separately reportable*.

Each administered developmental screening instrument is accompanied by an interpretation and report (e.g., a score or designation as *normal* or *abnormal*). Normal results might be recorded as, "Mother has no significant concerns about her child's fine motor, gross motor, expressive/receptive language, social interactions, or self-help skills." Abnormal results might be recorded as, "Mother has concerns about her child's expressive language and articulation, but no significant concerns about his fine motor, gross motor, receptive language, social interactions, or self-help skills." These interpretive remarks may be included on the screening form or in the progress note of the visit itself. Physicians are encouraged to document any interventions or referrals based on abnormal findings generated by the formal screening. If several tests are administered, results may be combined into a single report. Recommendations for interventions and other supportive measures should be included in the report summarizing the test results.

When developmental surveillance or screening suggests an abnormality in a particular area, more extensive formal objective testing is needed to evaluate the concern. Subsequent periodic formal testing may be needed to monitor the progress of a child whose skills initially may have not been significantly low, but who was clearly at risk for not maintaining appropriate acquisition of new skills.

These longer, more comprehensive developmental assessments using standardized instruments are typically reported using CPT codes. 96112, Developmental test administration and 96113, additional 30 minutes (List separately in addition to code for primary procedure).

These are tests of development, typically performed by physicians or other specially trained professionals, for which the physician work is included as part of the service. Codes 96112/96113 includes the testing and an accompanying formal report.

CPT defines 96112 as "developmental test administration (including assessment of fine and/or gross motor, language, cognitive level, social, memory and/or executive functions by standardized developmental instruments when performed), by physician or other qualified health care professional, with interpretation and report; first hour" and 96113,"Developmental test administration (including assessment of fine and/or gross motor, language, cognitive level, social, memory and/or executive functions by standardized developmental instruments when performed), by physician or other qualified health care professional, with interpretation and report; each additional 30 minutes (List separately in addition to code for primary procedure)." They are considered an intra-service that includes administration of assessment procedures and clinical observations of the patient's behavior during the actual testing process.

The following are clinical examples of the procedure from the AMA CPT book.

*“A 45-year-old male is 3 months status post cerebrovascular accident (CVA) in the distribution of the left middle cerebral artery. A careful language evaluation is required to determine the nature and extent of aphasia deficits and to make recommendations for rehabilitation. This code includes work in addition to and separate from the neurological evaluation.*

*Illustration: This code may be reported for the following case. A physician performs an assessment of the developmental status of a 3-year-old girl with spastic diplegia and no language in order to determine early intervention plan (placement in preschool for children with developmental delays). A neurological evaluation of the child has already been performed and a clinical interview with the child's mother preceded the decision for developmental testing.*

The frequency of reporting codes 96112/96113 are dependent on the needs of the patient and the judgment of the physician. CPT code 96112 describes no more than 1 hour of face-to-face work and may not be reported more than once a day for the patient. A minimum of 31 minutes must be provided to report any per hour code but the use of the 96113 cannot be applied until after a full 60 minutes has been utilized. Services 96112 and 96116 report time as face-to-face time with the patient and the time spent interpreting and preparing the report. If much less than a full hour is spent performing the service, the use of an E&M service would be appropriate.

When developmental testing is reported in conjunction with an E/M service, the time and effort to perform the developmental testing itself should not count toward the key components (history, physical examination, medical decision making) or time for selecting the accompanying E/M code. The E/M service should be reported with modifier 25 appended to reflect that the service was separate and medically necessary.

CPT code 96116 was redefined in 2019 as Neurobehavioral status examination (clinical assessment of thinking, reasoning and judgment, [eg, acquired knowledge, attention, language, memory, planning and problem solving, and visual spatial abilities]), by physician or other qualified health care professional, both face-to-face time with the patient and time interpreting test results and preparing the report; first hour. These tests are performed for the purpose of making a medical diagnosis. An additional add on code was developed for 2019 of 96121, defined as Neurobehavioral status exam (clinical assessment of thinking, reasoning and judgment, [eg, acquired knowledge, attention, language, memory, planning and problem solving, and visual spatial abilities]), by physician or other qualified health care professional, both face-to-face time with the patient and time interpreting test results and preparing the report; each additional hour (List separately in addition to code for primary procedure).

An example of a neurobehavioral status examination would be: an 8-year-old girl is showing significant changes in her behavior at home and school, including attention difficulties, memory problems, and difficulties with making decisions about common daily activities. Mother is concerned that the problems may be a result of the girl falling out of her crib when she was a toddler. The physician performs a neurobehavioral status examination that includes screening for impairments in attention and short-term memory, language, long-term memory, problem solving, and visual and spatial abilities. The physician observes the girl's behavior and records her responses.

Make sure you meet the definition for the code you are using. If you have questions, ask your state association or AOA Third Party committee or the medical director of the third party to whom you are submitting to for clarification in writing.



### **Which follow-up examination procedure codes should I use?**

After therapy has been initiated, you may choose to re-examine the patient at regular intervals. As long as you have the required documentation for history, examination and medical decision-making, you have several coding choices. These would include the same as the initial assessment and may include the special testing codes covered previously.

As this patient has already been seen in your office, only the established patient codes would be applicable.



### **Which therapy codes could I use?**

According to the Current Procedural Terminology Instructions for use of the CPT Codebook, doctors must select the name of the procedure or service that accurately identifies the service performed. Do not select a CPT code that merely approximates the service provided. When performing orthoptics, the appropriate code to use is 92065. This code is defined by CPT as orthoptic and/or pleoptic training, with continuing medical direction and evaluation, defines this code. Orthoptics are therapeutic procedures designed to improve the function of the eye muscles. These activities are particularly useful in the treatment of strabismus and other abnormalities of binocular vision. Orthoptics is commonly considered training and strengthening the muscles of the eye, so that they will work together properly. Pleoptics are exercises designed to improve impaired vision when there is no evidence of organic eye diseases.

It is uncommon for a doctor of optometry providing any form of vision therapy to provide only orthoptics. Some third-party networks expect professionals of each specialty group to bill the majority of their services within their specialty code set. They often are surprised when doctors of optometry bill outside the 92000 series, and they erroneously try to recode the procedure into the 92000 series. When performing other procedures, you may want to consider the Physical Medicine and Rehabilitation codes (97000 series).

### **What are Physical Medicine Codes?**

The 97000 series of CPT codes are considered “Physical Medicine and Rehabilitation.” Many payers are not aware of neuro-optometric rehabilitation and thus may assume that the codes will only be used by licensed occupational or physical therapists providing rehabilitation.

A key component to understanding the concept of rehabilitation coding is to understand the concept of habilitation. Habilitation is defined as assisting a child with achieving developmental skills when impairments have caused delaying or blocking of initial acquisition of the skills. Habilitation can include cognitive, social, fine motor, gross motor, or other skills that contribute to mobility, communication, and performance of activities of daily living and enhance quality of life.

The CPT code 97110 is for therapeutic exercises to develop strength and endurance, range of motion and flexibility. This could be considered for reimbursement when managing patients with convergence insufficiency or accommodative dysfunctions.



The CPT code 97112 is for neuromuscular reeducation of movement, balance coordination, kinesthetic sense, posture and proprioception. This could be considered for reimbursement when managing patients with eccentric fixation training.

The CPT code 97129 is for therapeutic interventions that focus on cognitive function (e.g., attention, memory, reasoning, executive function, problem solving, and/or pragmatic functioning) and compensatory strategies to manage the performance of an activity (e.g., managing time or schedules, initiating, organizing and sequencing tasks) with direct (one on one) patient contact. As a new code in 2018, CPT offers the following clinical example: A 30 year old male presents with traumatic brain injury sustained in a vehicular accident resulting in memory problems, distractibility, depression, inappropriate social interaction, inability to self-monitor, and impaired organizational skills for executive function.

The HCPCS code G0515 is similarly defined as development of cognitive skills to improve attention, memory, problem solving (includes compensatory training), direct (one-on-one) patient contact, each 15 minutes. CMS had created this code to temporarily replace the CPT code 97532 while 97127 and then 97129 were being developed. It is most appropriate for 2020 and beyond to use the CPT I code when billing.

The CPT code 97530 is for therapeutic activities utilized to restore a patient's functional performance with dynamic activities, such as training in specific functional movements or activities performed during daily living routines. This could be considered for reimbursement when managing patients with oculomotor/saccadic dysfunctions that are impacting performance.

The CPT code 97533 focuses on sensory integrative techniques to enhance sensory processing and to promote adaptive responses to environmental demands, with direct (one-on-one) patient contact by the clinician.

Multiple state boards of optometry have specifically approved these codes to be used by doctors of optometry. These codes may be used with patients who are in need of rehabilitative services to restore the function of the visual system and its connection to the vestibular and motor control function or the habilitation services described previously. The lack of understanding by insurance companies of the function of the doctor of optometry as a member of the rehabilitation team is part of this problem. The introduction to the CPT includes instructions that address this challenge. It states:

It is important to recognize that the listing of a service or procedure and its code number in a specific section of this book does not restrict its use to a specific specialty group. Any procedure or service in any section of this book may be used to designate the services rendered by any qualified physician or other health care professional.

Therefore, when choosing codes, the doctor of optometry must consider the following:

- Which services does my patient require?
- Which interventions are appropriate for my patient?
- Are there existing CPT code(s) that describes the service?
- Are the codes approved by the State Board of Optometry?

97110, 97112 and 97530 are examples of rehabilitation codes that insurance companies may want to change to 92065 when provided by a doctor of optometry. The 92065 code is defined as "Orthoptics

and/or pleoptic training, with continued medical direction and evaluation". In the classical definition, Orthoptics/Pleoptics is used to treat strabismus and amblyopia. In 2002, the Department of Health & Human Services Centers for Medicare & Medicaid Services alerted the physician and provider community that Medicare beneficiaries who are blind or visually impaired are eligible for physician-prescribed rehabilitation service. They have directed the providers to consider the physical medicine codes 97000 series for these services.

It should be clear that there is a significant difference between the rehabilitation codes (97000 codes) and the 92065 code. It is a misunderstanding of neuro-optometric rehabilitation that can lead insurance companies to question the use of rehabilitation codes by doctors of optometry. The key is effective communication and education of all involved.

You may want to consider the definitions of neuro-rehabilitation codes (97000 series codes). These codes, in the past, have been mistakenly called occupational or physical therapy codes. These are properly referred to as rehabilitation codes. Many state optometry boards specifically allow doctors of optometry to use these neuro-rehabilitation codes and some do not specify whether or not a doctor of optometry can use these codes in that state. Please check with your state board to see if you are allowed to use these codes. The 97000 series are timed codes as opposed to procedure codes. This means that they can be billed in multiple units per day.

The description of the service 92065 in the CPT manual includes "with continuing medical direction." This refers to the fact that each diagnosed problem is treated differently; therefore a specific treatment plan is established for the patient for each treatment visit. The specific treatment procedures are prescribed by the physician, based upon an evaluation of the overall diagnosis and progress made during previous visits. This treatment may be enhanced when the patient reinforces the in-office treatment at home with appropriate procedures. The home procedures are also prescribed by the physician as appropriate based upon progress made during in-office sessions as well as those previously prescribed out-of-office procedures. This sequence may require additional professional assessment, input and time to demonstrate and explain to the patient in order to assure quality, successful and cost-efficient treatment. This additional evaluation and management may be considered for reimbursement utilizing appropriate E&M or general ophthalmologic codes as long as the appropriate justification and documentation is provided.



### **How do I document to meet the coding requirements?**

When using the physical medicine codes, the physician or therapist is required to have direct (one-on-one) patient contact. This does not usually allow for "incident-to" billing. Furthermore, documentation guidelines are very specific and fairly complex. Documentation for the provision of vision therapy using 97000 codes should be identified in the indications section of the chart. Once they are established, an individual rehabilitation plan (IRP) must be entered into the patient's record. Minimum documentation requirements in the IRP and sessions executing the plan are as follows:

1. Patient's perceptions of visual function and measures of health-related quality of life (HRQOL).
2. During execution of the treatment plan, progress should be documented.
3. Specific goals based upon answers the patient has provided to questions about concerns; for example, "to increase reading speed to 100 words per minute".

4. A description of the method that will be employed to achieve each goal should be in the treatment plan.
5. Quantitative measurements of current performance measurements at each session should be compared to baseline performance measurements. A treatment plan may call for achieving goals in a sequential manner. Therefore, quantitative performance measurements of only the goals currently being addressed would be appropriate.
6. Sufficient time between visits is necessary for the patient to apply vision training to his or her activities of daily living. The vision specialist can assess the patient's improvement following practice by the patient with techniques to maximize performance. This may require periods of at least two (2) to five (5) days between visits.
7. When there is no progress in a quantitative measurement of performance on two occasions following the maximal measure of performance, subsequent treatment for that goal will be considered maintenance and will be considered by most insurers to be a noncovered benefit, payable by the patient.
8. A written progress report of each session is a required element of E&M service, and should identify changes in goals, therapy schedules, or treatment plan.
9. Each session utilizing therapeutic procedures or prolonged services, whose definition includes specific time requirements, must have the face-to-face time between the patient and physician or licensed therapist documented to the minute. Units are calculated as described in prolonged services. In the case of therapeutic services G0515, 97530, and 97533, a minimum of 15 minutes of face-to-face time for each unit of service must be billed. If less than 15 minutes of therapeutic procedure time is involved, no therapeutic service may be billed. If less than 30 minutes of a therapeutic service code face-to-face time is recorded, only one unit may be billed. Three units of therapeutic service require 45 to 60 minutes of face-to-face time.
10. Each session utilizing therapeutic procedures or services, whose definition does not include specific time requirements, must still have the face-to-face time between the patient and physician or licensed therapist documented. In the case of therapeutic services 92065 it is valued by the CMS Relative Value Committee based on physician time per session and limited to one session per day. Some carriers do allow for multiple units to be submitted on the same day, but documentation and medical necessity must warrant.



#### **Further documentation guidelines to successfully pass an audit**

The leading cause of payment errors for therapy services is "insufficient" documentation in the medical records. Documentation is often missing the required elements as outlined in the Centers for Medicare & Medicaid Services (CMS) Internet Only Manual (IOM) Publication 100-02, *Medicare Benefit Policy Manual*, Chapter 15, Sections 220 and 230 found at [www.cms.gov/Regulations-and-Guidance/Guidance/Manuals/downloads/bp102c15.pdf](http://www.cms.gov/Regulations-and-Guidance/Guidance/Manuals/downloads/bp102c15.pdf).

For example, a provider indicates in the medical record: "Plan of Care: We would like to see the patient three times per week to initiate exercises and modalities to decrease asthenopia and increase range of motion, strengthening vergences and improving function." This plan is missing key elements to support the medical necessity of the service, such as measurable long-term goals, the patient's diagnosis, the

proposed type, duration and frequency of services required to achieve each goal, or anticipated plan of discharge.

Additional widespread issues that result in "insufficient" documentation errors include:

- Missing or illegible signature on the plan of care;
- Missing or illegible signature for physician's certification; and
- Missing legible signature and required treatment minutes in narrative or on flow sheet.

The plan of care shall contain, at minimum, the following information as required by most payers:

- Diagnoses.
- Long-term treatment goals—should be developed for the entire episode of care and not only for the services provided under a plan for one interval of care.
- Type—may be physical therapy, occupational therapy, or speech language pathology, or when appropriate, the type may be a description of a specific treatment of intervention. When a physician or QHP establishes a plan, the plan must specify the type of therapy planned.
- Amount—refers to the number of times in a day the type of treatment will be provided. When amount is not specified, one treatment session a day is assumed.
- Duration—number of weeks or the number of treatment sessions for the plan of care.
- Frequency of therapy services—refers to the number of times in a week the type of treatment is provided. When frequency is not specified, one treatment is assumed.

The plan of care shall be consistent with the related evaluation. The plan should strive to provide treatment in the most efficient and effective manner, balancing the best achievable outcome with the appropriate resources.

#### **Signature and certification of the plan of care**

The legible signature and professional identity (e.g., OD, MD, OTR/L) of the individual who established the plan, as well as the date it was established, must be recorded with the plan. A physician or Qualified Health Provider (QHP) must certify (and date) the plan of care (\*note: for Comprehensive Outpatient Rehabilitation Facility-services, QHPs may not order or certify therapy services). Certification may be established in the patient's medical record through:

- Physician's or QHP's progress note
- Physician or QHP's order\*
- Plan of care that is signed and dated by a physician/QHP\*
- Documentation must indicate that the physician/QHP\* is aware that the therapy service is or was in progress; and
- Agrees with the plan, when there is evidence the plan was sent to the physician/QHP, or is available in the patient's medical record for the physician/QHP to review.

#### **Treatment notes**

The purpose of treatment notes is to create a record of all treatments and skilled interventions that are provided and to record the time of the services to justify the use of billing codes and units on the claim. Documentation is required for every treatment day and every therapy service.

Documentation of each treatment note must include the following required elements:

- Date of treatment.
- Identification of each specific intervention/modality provided and billed (both timed and untimed codes).
- Total timed code treatment minutes and total treatment time in minutes.
- Signature and professional identification of the qualified professional who furnished the services; or, for incident to services, supervised the services, including a list of each person who contributed to the treatment.



### **Who can submit 97000 codes?**

Medicare billable therapy services may be provided by any of the following providers within their scope of practice and consistent with state and local law: physician; non-physician practitioner (QHP) (physician assistants, nurse practitioners, clinical nurse specialists); qualified physical and occupational therapists, speech language pathologists (for CPT codes 97129 and 97533), and assistants working under the supervision of a qualified therapist; qualified personnel, with or without a license to practice therapy, who have been educated and trained as therapists and qualify to furnish therapy services only under direct supervision incident to a physician's service or QHP.

Services may be provided by a physician as defined in §1861 (r)(1) and (4) of the Social Security Act, a qualified occupational therapist, or a qualified physical therapist. Orientation and mobility specialists, low-vision therapists and rehabilitation teachers may also provide this type of therapy "incident to" a physician's service. Services furnished by an employee of the physician may only be done under the physician's direct personal supervision and must meet other "incident to" requirements provided in §2050 of the Medicare Carriers Manual. Direct supervision means that a physician must be in the immediate vicinity of the rehabilitation program, and immediately available or accessible for consultation or emergency. It does not require that the physician be physically present in the room itself. Certified occupational therapy and physical therapy assistants must perform under the appropriate level of supervision as with other therapy services.

"Incident to" services are integral but incidental to the physician's services. Measurement of a visual acuity or blood pressure, or recording a visual field or an electrocardiogram are skills easily taught to a technician and are considered an integral but incidental part of the physician's service. On the other hand, knowledge of optics and the teaching ability necessary to design, execute and adjust a vision rehabilitation plan require extended formal education and clinical experience. Therapeutic services and treatment-planning services are not incidental to vision rehabilitation; they are the determinants of success. Furthermore, these services are not well known or understood by most health care providers, and should not be performed without proper training.

A technician, for example, a paraoptometric, may collect data "incident to" physician's service as part of the vision evaluation or progress assessment, which are evaluation and management services. However, only a physician, occupational or physical therapist, or a professional possessing a certification whose state practice license specifically identifies vision rehabilitation as a service they may provide, may serve "incident to" a physician in the provision of visual rehabilitation.



All other delegation of vision therapy, vision rehabilitation, or other rehabilitative services to vision therapists (certified or not), teachers, paraoptometric, or other non-licensed staff is not covered by Medicare and many other payers and should not be billed with these Physical Medicine and Rehabilitation codes.

### **Therapy modifiers**

Providers must report a modifier for any applicable therapy code. The claim must include one of the following modifiers to distinguish the discipline of the plan of care under which the service is delivered:

- GN Services delivered under an outpatient speech-language pathology plan of care;
- GO Services delivered under an outpatient occupational therapy plan of care; or,
- GP Services delivered under an outpatient physical therapy plan of care.

When physicians bill rehabilitation codes, they must follow the policies of the type of therapy they are providing, e.g., utilize a plan of care, bill with the appropriate therapy modifier (GP, GO, GN), and bill the allowed units depending on the plan. These modifiers do not allow a provider to deliver services that they are not qualified and recognized by Medicare to perform. This is applicable to all claims from physicians. A physician shall not bill a rehabilitation code unless the service is provided under a therapy plan of care. All therapy services that a doctor of optometry would provide, aside from the 92065 orthoptic code, are consistent with the occupational therapy model of Physical Medicine and Rehabilitation. The GO modifier is, therefore, most appropriate for all 97000 codes that apply to vision therapy and neuro-optometric rehabilitation.

- Modifier KX-Requirements specified in the medical policy have been met

The beneficiary may qualify for use of the cap exceptions process at any time during the episode when documented medically necessary services exceed caps. All covered and medically necessary services qualify for exceptions to caps. All requests for exception are in the form of a KX modifier added to claim lines. Use of the exception process does not exempt services from manual or other medical review processes. Rather, atypical use of the exception process may invite contractor scrutiny, for example, when the KX modifier is applied to all services on claims that are below the therapy caps or when the KX modifier is used for all beneficiaries of a therapy provider. To substantiate the medical necessity of the therapy services, document in the medical record. The KX modifier is added to claim lines to indicate that the clinician attests that services at and above the therapy caps are medically necessary and justification is documented in the medical record.

### **Medicare Outpatient Therapy Caps**

The Medicare Part B outpatient therapy caps limited the amount of rehabilitation services Medicare would cover per year. These caps were first implemented in 1999 and were enforced for limited periods through 2005. Since 2006, an exceptions process was enacted allowing for medically necessary therapy services above the cap amounts. However, the exceptions process provisions expired at the end of 2017. Prior to January 1, 2018, Medicare would only cover \$2,010 of physical therapy/speech language therapy services combined, and \$2,010 of occupational therapy services per year. There were no exceptions - even if the therapy was urgently needed for a beneficiary to restore function to remain home, return home, or to maintain their quality of life.

In February 2018, the therapy caps were repealed by the federal budget - This means there are no longer any artificial annual limits. The repeal was retroactive to January 1, 2018 - This means that if you had any residents that had claims denied because they went over the \$2,010 cap threshold in 2018 so far, you should be able to resubmit the claims for payment. This should also apply to Medicare Advantage denials as these plans must offer comparable coverage but we are awaiting specific CMS guidance for such situations.

You will still need to submit a KX modifier on claims for any beneficiary services furnished over the cap annually for PT and SLP services combined. This modifier is being used as an attestation of medical necessity. Claims over \$2,040 annual thresholds will be denied for noncompliance if not submitted with this coding requirement.

For 2020, CMS is proposing adding a paragraph to existing regulations clarifying that the previous annual limitation known as the “therapy cap” is now a threshold amount. Once therapy services billed reach the threshold amount (as determined annually by the Medicare Economic Index and released in November), the KX modifier must be appended to any services billed indicating that the services are medically necessary and are justified as such in therapy documentation. Additionally, CMS is proposing adding a paragraph to the regulation clarifying that the annual threshold amount for targeted medical review continues to be \$3,000 for occupational therapy services and will remain at that amount until 2028 without change.



### **Should I code every patient?**

Coding is very similar to learning a foreign language. You must use it to master it. With this in mind, the best approach is to code every patient coming through the office for every visit. By coding everyone, you will master the system faster. Once you begin to code everyone for everything, you will find that thinking in codes becomes second nature.



### **What should I know about diagnosis coding rules?**

1. Code to the highest level of specificity. Don't code strabismus as H50.00 Unspecified Esotropia, instead code for the specific esotropia the patient has (e.g. H50.031 = Monocular Esotropia right eye with V Pattern).
2. Avoid “unspecified” codes.
3. The procedure code must be relevant to the diagnosis code.
4. A single diagnosis may require more than one code. These are identified in the codebooks as codes in brackets. The code in brackets is mandatory. (e.g., Hypertensive Retinopathy H35.033 requires HTN I.10 to be mutually coded.)
5. It may require more than one diagnosis or procedure code to completely describe the patient because the patient has multiple problems.
6. For more information and resources on ICD-10, visit [aoa.codingtoday.com/](http://aoa.codingtoday.com/) or [aoa.org/optometrists/tools-and-resources/medical-records-and-coding/icd-10](http://aoa.org/optometrists/tools-and-resources/medical-records-and-coding/icd-10).
7. You can purchase the complete *Codes for Optometry* at [store.aoa.org/Product/viewproduct/?ProductId=3632850](http://store.aoa.org/Product/viewproduct/?ProductId=3632850)

### **Which clinical standards are used to evaluate my claim?**

The most widely circulated optometric documents that deal with therapy duration currently include: AOA optometric clinical practice guidelines on (1) *Care of the Patient with Amblyopia*, (2) *Care of the Patient with Strabismus* and (3) *Care of the Patient with Accommodative and Vergence Dysfunction*.

Complete versions of the guidelines can be accessed on the AOA website at [aoa.org/patients-and-public/caring-for-your-vision/clinical-practice-guidelines](http://aoa.org/patients-and-public/caring-for-your-vision/clinical-practice-guidelines).

COVD fact sheets on Conditions of the Visual System Treated with Vision Therapy may also be used and can be obtained from the COVD office (1.888.268.3770). Various position papers and white papers may also be obtained from the COVD office or from the website [covid.org/?page=VisionConditions](http://covid.org/?page=VisionConditions).

Additional resources are included at the end of this document that can be included with all letters to third-party insurance carriers.



### **What are some good insurance tips?**

1. If you are going to bill orthoptics (92065), there is no need to write insurance pre-determination to insurance companies you have already determined do or do not cover orthoptic therapy. Pre-determination letters are beneficial if you are not certain whether a particular insurance company covers orthoptic therapy or if you need to determine the number of sessions a particular patient's policy will cover.
2. If you are going to bill vision rehabilitation (97xxx), there is no need to write insurance pre-determination to insurance companies you have already determined do or do not cover rehabilitation therapy. Pre-determination letters are beneficial if you are not certain whether a particular insurance company covers rehabilitation therapy or if you need to determine the number of sessions a particular patient's policy will cover.
3. Appeal letters are successful if you can "convince" an insurance company that a procedure was medically necessary. Pre-determination and appeal letters are very time-consuming and many offices charge the patient an appropriate fee to write these letters, which includes sending all the appropriate documentation. (See the "Forms/Letters" section of this manual for a sample pre-determination and appeal letter.)
4. Verbal verification or authorization of insurance benefits is not binding. Don't "guarantee" that a patient's insurance company will pay for testing or therapy procedures, even if a written insurance verification is obtained. Always inform the patient that they are responsible for all fees not covered by his or her insurance, no matter the reason stated in the denial.
5. Be aware that an insurance company can deny reimbursement at any time during or for a limited time after the therapy process. An insurance company may pay for 10 visits and then request a medical review. As a result of this review, they may deny further coverage and in some cases, can even demand reimbursement for therapies previously covered. Thus, again, it is important to inform the patient *in advance* that he or she is responsible for all services denied or not covered by their insurance company.
6. When dealing with out-of-network insurance companies, collect 100 percent of all fees from the patient at the time of service. However, it is beneficial for the vision therapy doctor's office to file these claims for the patient, as a professional courtesy.



7. When dealing with in-network insurance companies, most providers have found it "safe" to collect only the patient's co-pay for the testing procedures. However, unless you have obtained a written prior authorization notification stating orthoptic therapy or rehabilitation is a covered service by a patient's particular insurance company, there is no guarantee that the patient won't be responsible for additional fees.
8. Most successful practices do file for insurance when applicable; however successful practices often have someone on staff that can market the vision therapy program without relying upon insurance coverage.
9. Documentation is extremely important. Make sure the doctor maintains detailed, up-to-date office notes on all patient visits, as well as the therapist/doctor keeping a log of daily therapy procedures used with the patient. In case of a medical review, these notes will be requested by the insurance company. Successful appeals are usually won based upon these office notes, along with the written testing reports.
10. Keep an updated list of all insurance companies that cover the testing and/or therapy sessions. Include the amount of reimbursement collected for each procedure code. Document the diagnosis codes used successfully for each procedure with each company. This list is an invaluable source for the successful vision therapy practice.
11. Be aware that just because one particular insurance company's policy covers vision therapy does not mean that all policies associated with this company will cover vision therapy. Also be aware that an insurance company may cover vision therapy one year, and the next year may elect not to do so.
12. Keep in mind insurance companies are much more likely to cover vision therapy for visual efficiency areas than they are for visual perceptual areas.

**Acknowledgment:**

The AOA and COVD would like to acknowledge Harvey B. Richman, O.D, FCOVD for his major contributions to the research and preparation of this document. A number of editorial revisions were based on the recommendations of the following individuals and organizations: Leonard Press, O.D., FCOVD, Richard Soden, O.D., FCOVD, Jason Clopton, O.D., FCOVD, and the College of Optometrists in Vision Development (COVD). This document is based on the COVD members-only Chapter 10 "How to Build a Successful Vision Therapy Practice" and the AOA Vision Therapy Fact Sheets. The members of the 2016-2017 AOA InfantSEE® & Children's Vision Committee, Glen Steele, O.D., FCOVD, chairman and AOA Third Party Committee, Steven Eiss, O.D., chairman, contributed to the final development of this document.

## APPENDICES

The following appendices are intended as general guides and samples. These resources must be tailored and revised to fit the specific needs of your practice, patients, and circumstances.

---

- A) Overview of Coding Procedures
- B) Definition of Optometric Vision Therapy
- C) Optometric Vision Therapy Fact Sheets
- D) Predetermination of Coverage 92065 (FCOVD)
- E) Predetermination of Coverage 92065 (non-FCOVD)
- F) Preauthorization Request
- G) Letter of Request for Additional Information 92065 (FCOVD)
- H) Letter of Request for Additional Information 92065 (non-FCOVD)
- I) Letter of Request for Additional Information 97XXX (FCOVD)
- J) Letter of Request for Additional Information 97XXX (non-FCOVD)
- K) Letter for Denied Claim
- L) Letter for Additional Sessions
- M) Letter Explaining Difference Between Sensorimotor vs. Eye Examination
- N) Explanation of Patient's Responsibility with Insurance Coverage – Non-participating Physicians
- O) Explanation of Patient's Responsibility with Insurance Coverage – Denial Review
- P) Alternative Sample Insurance Coverage Form
- Q) Joint Position Statement on Vision Therapy (AOA-AAO)\*
- R) Efficacy of Optometric Vision Therapy (AOA)\*
- S) The Scientific Basis for and Efficacy of Optometric Vision Therapy in Non-strabismic Accommodative and Vergence Disorders (AOA)\*

\*These can be submitted with letters D) through L) as additional documentation.

## A) Overview of Coding Procedures

### General ophthalmologic services

- 92002** Ophthalmological services: medical examination and evaluation with initiation of diagnostic and treatment program; intermediate, new patient
- 92004** Ophthalmological services: medical examination and evaluation with initiation of diagnostic and treatment program; comprehensive, new patient, 1 or more visits
- 92012** Ophthalmological services: medical examination and evaluation, with initiation or continuation of diagnostic and treatment program; intermediate, established patient
- 92014** Ophthalmological services: medical examination and evaluation, with initiation or continuation of diagnostic and treatment program; comprehensive, established patient, 1 or more visits
- 92015** Determination of refractive state

### Special ophthalmological services

- 92060** Sensorimotor examination with multiple measurements of ocular deviation (e.g., restrictive or parietic muscle with diplopia) with interpretation and report (separate procedure)
- 92270** Electro-oculography with interpretation and report

### Special otorhinolaryngologic services vestibular function tests, with observation and evaluation by physician, w/o electrical recording

- 92531** Spontaneous nystagmus, including gaze
- 92532** Positional nystagmus test
- 92534** Optokinetic nystagmus test

### Neurology and neuromuscular procedures

- 95930** Visual evoked potential (VEP) testing central nervous system, checkerboard or flash
- 0333T** Visual evoked potential screening for visual acuity
- 0464T** Visual evoked potential testing for glaucoma

**Central nervous system assessments/tests (e.g., neuro-cognitive, mental status)**

The following codes are used to report the services provided during testing of the cognitive function of the central nervous system. The testing of cognitive processes, visual motor responses, and abstractive abilities is accomplished by the combination of several types of testing procedures. It is expected that the administration of these tests will generate material that will be formulated into a report.

~~Note: 96101 was DELETED in 2019— See 96130~~

- 96110** Developmental testing; limited (e.g., Developmental Screening Test II, Early Language Milestone Screen), with interpretation and report
- 96112** Developmental test administration (including assessment of fine and/or gross motor, language, cognitive level, social, memory and/or executive functions by standardized developmental instruments when performed), by physician or other qualified health care professional, with interpretation and report; first hour
- 96113** Developmental test administration (including assessment of fine and/or gross motor, language, cognitive level, social, memory and/or executive functions by standardized developmental instruments when performed), by physician or other qualified health care professional, with interpretation and report; each additional 30 minutes (List separately in addition to code for primary procedure)
- 96116** Neurobehavioral status examination (clinical assessment of thinking, reasoning and judgment, [eg, acquired knowledge, attention, language, memory, planning and problem solving, and visual spatial abilities]), by physician or other qualified health care professional, both face-to-face time with the patient and time interpreting test results and preparing the report; first hour
- 96121** Neurobehavioral status exam (clinical assessment of thinking, reasoning and judgment, [eg, acquired knowledge, attention, language, memory, planning and problem solving, and visual spatial abilities]), by physician or other qualified health care professional, both face-to-face time with the patient and time interpreting test results and preparing the report; each additional hour (List separately in addition to code for primary procedure)

**96130** Psychological testing evaluation services by physician or other qualified health care professional, including integration of patient data, interpretation of standardized test results and clinical data, clinical decision making, treatment planning and report, and interactive feedback to the patient, family member(s) or caregiver(s), when performed; first hour

**96131** Psychological testing evaluation services by physician or other qualified health care professional, including integration of patient data, interpretation of standardized test results and clinical data, clinical decision making, treatment planning and report, and interactive feedback to the patient, family member(s) or caregiver(s), when performed; each additional hour (List separately in addition to code for primary procedure)

### **Health and behavior assessment/intervention**

~~Health and behavior assessment procedures are used to identify the psychological, behavioral, emotional, cognitive and social factors important to the prevention, treatment or management of physical health problems. The focus of the assessment is not on mental health but on the biopsychosocial factors important to physical health problems and treatments. The focus of the intervention is to improve the patient's health and wellbeing utilizing cognitive, behavioral, social and/or psychophysiological procedures designed to ameliorate specific disease-related problems. Codes 96514-96515 describe services offered to patients who present with primary physical illnesses, diagnoses or symptoms and may benefit from assessments and interventions that focus on the biopsychosocial factors related to the patient's health status. These services do not represent preventive medicine counseling and risk factor reduction interventions.~~

### **Health Behavior Assessment and Intervention**

Health behavior assessment and intervention services are used to identify and address the psychological, behavioral, emotional, cognitive, and interpersonal factors important to the assessment, treatment, or management of physical health problems.

The patient's primary diagnosis is physical in nature and the focus of the assessment and intervention is on factors complicating medical conditions and treatments. These codes describe assessments and interventions to improve the patient's health and well-being utilizing psychological and/or psychosocial interventions designed to ameliorate specific disease-related problems.

**Health behavior assessment:** includes evaluation of the patient's responses to disease, illness or injury, outlook, coping strategies, motivation, and adherence to medical treatment. Assessment is conducted through health- focused clinical interviews, observation, and clinical decision making.

**Health behavior intervention:** includes promotion of functional improvement, minimizing psychological and/ or psychosocial barriers to recovery, and management of and improved coping with medical conditions. These services emphasize active patient/family engagement and involvement. These interventions may be provided individually, to a group (two or more patients), and/or to the family, with or without the patient present.

Codes 96156, 96158, 96159, 96164, 96165, 96167, 96168, 96170, 96171 describe services offered to patients who present with primary physical illnesses, diagnoses, or symptoms and may benefit from assessments and interventions that focus on the psychological and/or psychosocial factors related to the patient's health status. These services do not represent preventive medicine counseling and risk factor reduction interventions.

Evaluation and management services codes (including counseling risk factor reduction and behavior change intervention [99401-99412]) should not be reported on the same day as health behavior assessment and intervention codes 96156, 96158, 96159, 96164, 96165, 96167, 96168, 96170, 96171 by the same provider.

Health behavior assessment and intervention services (96156, 96158, 96159, 96164, 96165, 96167, 96168, 96170, 96171) can occur and be reported on the same date of service as evaluation and management services (including counseling risk factor reduction and behavior change intervention [99401, 99402, 99403, 99404, 99406, 99407, 99408, 99409, 99411, 99412]), as long as the health behavior assessment and intervention service is reported by a physician or other qualified health care professional and the evaluation and management service is performed by a physician or other qualified health care professional who may report evaluation and management services.

Do not report 96158, 96164, 96167, 96170 for less than 16 minutes of service.

**These codes are new for 2020!**

- |              |   |
|--------------|---|
| <b>96156</b> | Health behavior assessment, or re-assessment (ie, health-focused clinical interview, behavioral observations, clinical decision making) |
| <b>96158</b> | Health behavior intervention, individual, face-to-face; initial 30 minutes  |
| <b>96159</b> | each additional 15 minutes (List separately in addition to code for primary service)<br>>(Use 96159 in conjunction with 96158)<         |
| <b>96167</b> | Health and behavior intervention, initial 30 minutes, face-to-face; family (with the patient present)                                   |
| <b>96168</b> | each additional 15 minutes (List separately in addition to code for primary service)<br>>(Use 96168 in conjunction with 96167)<         |
| <b>96170</b> | Health and behavior intervention, initial 30 minutes, face-to-face; family (without the patient present)                                |
| <b>96171</b> | each additional 15 minutes (List separately in addition to code for primary service)<br>>(Use 96171 in conjunction with 96170)<         |

## Evaluation and management codes for diagnosis

- 99201** Office or other outpatient visit for the evaluation and management of a new patient, which requires these 3 key components: a problem-focused history; a problem-focused examination; straightforward medical decision making. Counseling and/or coordination of care with other providers or agencies are provided consistent with the nature of the problem(s) and the patient's and/or family's needs. Usually, the presenting problem(s) are self limited or minor. Physicians typically spend 10 minutes face-to-face with the patient and/or family.
- 99202** Office or other outpatient visit for the evaluation and management of a new patient, which requires these 3 key components: an expanded problem-focused history; an expanded problem-focused examination; straightforward medical decision making. Counseling and/or coordination of care with other providers or agencies are provided consistent with the nature of the problem(s) and the patient's and/or family's needs. Usually, the presenting problem(s) are of low to moderate severity. Physicians typically spend 20 minutes face-to-face with the patient and/or family.
- 99203** Office or other outpatient visit for the evaluation and management of a new patient, which requires these 3 key components: a detailed history; a detailed examination; medical decision making of low complexity. Counseling and/or coordination of care with other providers or agencies are provided consistent with the nature of the problem(s) and the patient's and/or family's needs. Usually, the presenting problem(s) are of moderate severity. Physicians typically spend 30 minutes face-to-face with the patient and/or family.
- 99204** Office or other outpatient visit for the evaluation and management of a new patient, which requires these 3 key components: a comprehensive history; a comprehensive examination; medical decision making of moderate complexity. Counseling and/or coordination of care with other providers or agencies are provided consistent with the nature of the problem(s) and the patient's and/or family's needs. Usually, the presenting problem(s) are of moderate to high severity. Physicians typically spend 45 minutes face-to-face with the patient and/or family.
- 99205** Office or other outpatient visit for the evaluation and management of a new patient, which requires these 3 key components: a comprehensive history; a comprehensive examination; medical decision making of high complexity. Counseling and/or coordination of care with other providers or agencies are provided consistent with the nature of the problem(s) and the patient's and/or family's needs. Usually, the presenting problem(s) are of moderate to high severity. Physicians typically spend 60 minutes face-to-face with the patient and/or family.
- 99211** Office or other outpatient visit for the evaluation and management of an established patient, that may not require the presence of a physician. Usually, the presenting problem(s) are minimal. Typically, five minutes are spent performing or supervising these services.

- 99212** Office or other outpatient visit for the evaluation and management of an established patient, which requires at least 2 of these 3 key components: a problem-focused history; a problem-focused examination; straightforward medical decision making. Counseling and/or coordination of care with other providers or agencies are provided consistent with the nature of the problem(s) and the patient's and/or family's needs. Usually, the presenting problem(s) are self limited or minor. Physicians typically spend 10 minutes face-to-face with the patient and/or family.
- 99213** Office or other outpatient visit for the evaluation and management of an established patient, which requires at least 2 of these 3 key components: an expanded problem-focused history; an expanded problem-focused examination; medical decision making of low complexity. Counseling and coordination of care with other providers or agencies are provided consistent with the nature of the problem(s) and the patient's and/or family's needs. Usually, the presenting problem(s) are of low to moderate severity. Physicians typically spend 15 minutes face-to-face with the patient and/or family.
- 99214** Office or other outpatient visit for the evaluation and management of an established patient, which requires at least 2 of these 3 key components: a detailed history; a detailed examination; medical decision making of moderate complexity. Counseling and/or coordination of care with other providers or agencies are provided consistent with the nature of the problem(s) and the patient's and/or family's needs. Usually, the presenting problem(s) are of moderate to high severity. Physicians typically spend 25 minutes face-to-face with the patient and/or family.
- 99215** Office or other outpatient visit for the evaluation and management of an established patient, which requires at least 2 of these 3 key components: a comprehensive history; a comprehensive examination; medical decision making of high complexity. Counseling and/or coordination of care with other providers or agencies are provided consistent with the nature of the problem(s) and the patient's and/or family's needs. Usually, the presenting problem(s) are of moderate to high severity. Physicians typically spend 40 minutes face-to-face with the patient and/or family.

### **Prolonged services**

Codes 99354, 99355, 99356 and 99357 are used when a physician provides prolonged service involving direct (face-to-face) patient contact that is beyond the usual service in either the inpatient or outpatient setting. This service is reported in addition to other physician service, including evaluation and management services at any level. Appropriate codes should be selected for supplies provided or procedures performed in the care of the patient during this period. Codes 99354, 99355, 99356 and 99357 are used to report the total duration of face-to-face time spent by a physician on a given date providing prolonged service, even if the time spent by the physician on that date is not continuous. Code 99354 or 99356 is used to report the first hour of prolonged service on a given date, depending on the place of service. Either code also may be used to report a total duration of prolonged service of 30-60 minutes on a given date. Either code should be used only once per date, even if the time spent by the physician is not continuous on that date. Prolonged service of less than 30 minutes total duration on a given date is not separately reported because the work involved is included in the total work of the evaluation and management codes. Code 99355 or 99357 are used to report each additional 30 minutes beyond the first hour, depending on the place of service. Either code may also be



used to report the final 15-30 minutes of prolonged service on a given date. Prolonged service of less than 15 minutes beyond the first hour or less than 15 minutes beyond the final 30 minutes is not reported separately. The following examples illustrate the correct reporting of prolonged physician service with direct patient contact in the office setting:

**99354** Prolonged physician service in the office or other outpatient setting requiring direct (face-to-face) patient contact beyond the usual service; first hour (list separately in addition to code for office or other outpatient evaluation and management service)

**99355** Prolonged physician service in the office or other outpatient setting requiring direct (face-to-face) patient contact beyond the usual service; each additional 30 minutes (list separately in addition to code for prolonged physician service)

Codes 99358 and 99359 are used when a physician provides prolonged service not involving direct (face-to-face) care that is beyond the usual service in either the inpatient or outpatient setting. This service is to be reported in addition to other physician service, including evaluation and management services at any level. Codes 99358 and 99359 are used to report the total duration of non-face-to-face time spent by a physician on a given date providing prolonged service, even if the time spent by the physician on that date is not continuous. Code 99358 is used to report the first hour of prolonged service on given date regardless of the place of service. It may also be used to report a total duration of prolonged service of 30-60 minutes on a given date. It should be used only once per date even if the time spent by the physician is not continuous on that date. Prolonged service of less than 30 minutes total duration on a given date is not separately reported. Code 99359 is used to report each additional 30 minutes beyond the first hour regardless of the place of service. It may also be used to report the final 15-30 minutes of prolonged service on a given date. Prolonged service of less than 15 minutes beyond the first hour or less than 15 minutes beyond the final 30 minutes is not reported separately.

**99358** Prolonged evaluation and management service before and/or after direct (face-to-face) patient care (e.g., review of extensive records and tests, communication with other professionals and/or the patient/family); first hour (list separately in addition to code(s) for other physician service(s) and/or inpatient or outpatient evaluation and management service)

**99359** Prolonged evaluation and management service before and/or after direct (face-to-face) patient care (e.g., review of extensive records and tests, communication with other professionals and/or the patient/family); each additional 30 minutes (list separately in addition to code for prolonged physician service)

### **Case management services**

Physician case management is a process in which a physician is responsible for direct care of a patient, and for coordinating and controlling access to or initiating and/or supervising other health care services needed by the patient.

- 99368** Medical team conference with interdisciplinary team of health care professionals, patient and/or family not present, 30 minutes or more; participation by nonphysician qualified health care professional
- 99441** Telephone evaluation and management service provided by a physician to an established patient, parent or guardian not originating from a related E/M service provided within the previous 7 days nor leading to an E/M service or procedure within the next 24 hours or soonest available appointment; 5-10 minutes of medical discussion
- 99442** Telephone evaluation and management service provided by a physician to an established patient, parent or guardian not originating from a related E/M service provided within the previous 7 days nor leading to an E/M service or procedure within the next 24 hours or soonest available appointment; 11-20 minutes of medical discussion
- 99443** Telephone evaluation and management service provided by a physician to an established patient, parent or guardian not originating from a related E/M service provided within the previous 7 days nor leading to an E/M service or procedure within the next 24 hours or soonest available appointment; 21-30 minutes of medical discussion

### **Therapeutic procedures and diagnostic tests**

#### **Special ophthalmological services**

- 92065** Orthoptic and/or pleoptic training, with continuing medical direction and evaluation
- 92499** Unlisted ophthalmological service or procedure

#### **Physical medicine and rehabilitation**

A manner of effecting change through the application of clinical skills and/or services that attempt to improve function. Physician or therapist required to have direct (one-on-one) patient contact.

- 97110** Therapeutic procedure, one or more areas, each 15 minutes; therapeutic exercises to develop strength and endurance, range of motion and flexibility
- 97112** Neuromuscular reeducation of movement, balance, coordination, kinesthetic sense, posture, and/or proprioception for sitting and/or standing activities
- 97116** Gait training (includes stair climbing)

- ~~97127~~      **Note 97127 was deleted for 2020**
- 97129**      **NEW FOR 2020!** Therapeutic interventions that focus on cognitive function (eg, attention, memory, reasoning, executive function, problem solving, and/or pragmatic functioning) and compensatory strategies to manage the performance of an activity (eg, managing time or schedules, initiating, organizing, and sequencing tasks), direct (one-on-one) patient contact; initial 15 minutes (Report 97129 only once per day)
- 97139**      Unlisted therapeutic procedure (specify)
- 97150**      Therapeutic procedure(s), group (2 or more individuals)  
(Report 97150 for each member of group)  
(Group therapy procedures involve constant attendance of the physician or therapist, but by definition do not require one-on-one patient contact by the physician or therapist)
- 97530**      Therapeutic activities, direct (one-on-one) patient contact by the provider (use of dynamic activities to improve functional performance), each 15 minutes
- 97533**      Sensory integrative techniques to enhance sensory processing and promote adaptive responses to environmental demands, direct (one-on-one) patient contact by the provider, each 15 minutes
- 97535**      Self-care/home management training (e.g., activities of daily living (ADL) and compensatory training, meal preparation, safety procedures, and instructions in use of assistive technology devices/adaptive equipment) direct one-on-one contact by provider, each 15 minutes
- 97537**      Community/work reintegration training (e.g., shopping, transportation, money management, avocational activities and/or work environment/modification analysis, work task analysis, use of assistive technology device/adaptive equipment), direct one-on-one contact by provider, each 15 minutes
- 97750**      Physical performance test or measurement (e.g., musculoskeletal, functional capacity), with written report, each 15 minutes
- 97755**      Assistive technology assessment (e.g., to restore, augment or compensate for existing function, optimize functional tasks and/or maximize environmental accessibility), direct one-on-one contact by provider, with written report, each 15 minutes
- 97799**      Unlisted physical medicine/rehabilitation service or procedure
- G0515**      Development of cognitive skills to improve attention, memory, problem solving (includes compensatory training), direct (one-on-one) patient contact, each 15 minutes

This document is:

1. Current at the time it was published;
2. Based on Medicare and third-party policy that changes frequently and are available for your reference;
3. Prepared as a tool to assist providers and is not intended to grant rights or impose obligations;
4. Developed with reasonable effort to assure the accuracy of the information; and
5. A general summary that explains certain aspects of the Medicare Program, but is not a legal document. The official Medicare Program provisions are contained in the relevant laws, regulations and rulings.

*Ultimate responsibility for the correct submission of claims and response to any remittance advice lies with the provider of services.*

*The Medicare Learning Network (MLN) is the brand name for official CMS educational products and information for Medicare fee-for-service providers. For additional information visit the Medicare Learning Network's web page at [cms.hhs.gov/MLNGenInfo](https://cms.hhs.gov/MLNGenInfo) on the CMS website.*

*Current Procedural Terminology (CPT) is copyright 2018 American Medical Association. All Rights Reserved. No fee schedules, basic units, relative values, or related listings are included in CPT. The AMA assumes no liability for the data contained herein. Applicable FARS/DFARS restrictions apply to government use.*

*The AOA, its agents and staff make no representation, warranty or guarantee that this compilation of coding information is error-free and will bear no responsibility or liability for the results or consequences of the use of this guide.*

## **B) Definition of Optometric Vision Therapy**

Optometric vision therapy is a sequence of neurosensory and neuromuscular activities individually prescribed and monitored by the doctor of optometry to develop, rehabilitate and enhance visual skills and processing. The optometric vision therapy program is based on the results of a comprehensive eye examination or consultation, and takes into consideration the results of standardized tests, the needs of the patient, and the patient's signs and symptoms. The use of lenses, prisms, filters, occluders, specialized instruments, and computer programs is an integral part of optometric vision therapy. The length of the therapy program varies depending on the severity of the diagnosed conditions, typically ranging from several months to longer periods of time. Activities paralleling in-office techniques are typically taught to the patient to be practiced at home, thereby reinforcing the developing visual skills.

Research has demonstrated optometric vision therapy can be an effective treatment option for:

- Ocular motility dysfunctions (eye movement disorders)
- Nonstrabismic binocular disorders (inefficient eye teaming)
- Strabismus (misalignment of the eyes)
- Amblyopia (poorly developed vision)
- Accommodative disorders (focusing problems)
- Visual information processing disorders, including visual-motor integration and integration with other sensory modalities
- Visual sequela of acquired brain injury

*Approved by the American Optometric Association Board of Trustees, April 2009*

**Optometry: The Profession**

Optometry is an independent primary health care profession.

Doctors of optometry (ODs) are the primary health care professionals for the eye. Doctors of optometry examine, diagnose, treat and manage diseases, injuries and disorders of the visual system, the eye and associated structures, as well as identify related systemic conditions affecting the eye.

Doctors of optometry prescribe medications, low-vision rehabilitation, vision therapy, spectacle lenses, contact lenses, and perform certain surgical procedures. They counsel their patients regarding surgical and nonsurgical options that meet their visual needs related to their occupations, avocations and lifestyle.

Doctors of optometry are eye health care professionals state licensed to diagnose and treat diseases and disorders of the eye and visual system.

A doctor of optometry has completed pre-professional undergraduate education in a college or university and four years of professional education at a college of optometry, leading to the doctor of optometry (O.D.) degree. Some doctors of optometry complete an optional residency in a specific area of practice.

### C) **Optometric Vision Therapy Fact Sheets**

These fact sheets include information regarding the treatment and management of various conditions with optometric vision therapy. Because of the differences in complexity of conditions and management approaches, this information should be used only as a guideline. Should specific questions arise not addressed by these materials regarding the appropriateness of patient care, peer review of the services provided may be warranted. Information about ICD-10 coding for the following conditions can be found on page 12 of this document (see: What should I know about diagnosis coding rules?)

#### **ACCOMMODATIVE DISORDER**

Definition-A sensory and neuromuscular anomaly of the visual system distinct from presbyopia and refractive anomalies. An accommodative dysfunction can be characterized by inadequate accommodative accuracy, reduced facility and flexibility, reduced amplitude of accommodation or the inability to sustain accommodation.

#### Signs and symptoms

The signs and symptoms associated with an accommodative dysfunction are related to prolonged, visually demanding, near-centered tasks such as reading. They may include, but are not limited to, the following:

1. Asthenopia
2. Transient blurred vision
3. Photophobia
4. Abnormal fatigue
5. Headaches
6. Difficulty sustaining near visual function
7. Dizziness
8. Abnormal postural adaptation/abnormal working distance
9. Pain in or around the eye

#### Diagnostic factors

Accommodative dysfunctions are characterized by one or more of the following diagnostic findings:

1. Low accommodative amplitude relative to age
2. Reduced accommodative facility between near and far targets
3. Reduced ranges of relative accommodation
4. Abnormal lag of accommodation
5. Unstable accommodation

#### Therapeutic considerations

##### A. Management

The doctor of optometry determines appropriate diagnostic and therapeutic modalities, and frequency of evaluation and follow-up, based upon the urgency and nature of the patient's condition and unique needs. The management of the case and duration of the treatment would be affected by:

1. The severity of symptoms and diagnostic factors including onset and duration of the problem
2. Implications of patient's general health and associated visual condition

3. Extent of visual demands placed upon the individual
4. Patient compliance
5. Prior interventions

#### B. Treatment

A number of cases are successfully managed by prescription of therapeutic lenses and/or prisms. However, accommodative dysfunctions may also require optometric vision therapy. Optometric vision therapy usually incorporates the prescription of specific treatments in order to:

1. Normalize accommodative amplitude relative to age
2. Normalize ability to sustain accommodation
3. Normalize relative ranges of accommodation
4. Normalize accommodative facility relative to age
5. Normalize accommodative/convergence relationship
6. Integrate accommodative function with information processing

#### Duration of treatment

Accommodative Disorder rarely exists in isolation. The function of the visual system is dependent on the integration of multiple visual skills. The required duration of treatment is extended commensurate with the severity and/or complexity of the problem.

1. Accommodative dysfunction usually requires 12 hours of office therapy.
2. Accommodative dysfunction complicated by:
  - a. accommodative/convergence abnormalities: up to an additional 16 hours of office therapy
  - b. other diagnosed visual anomalies: may require additional therapy
  - c. associated conditions such as stroke, head trauma, or other systemic diseases: may require substantially more office therapy

#### Follow-up care

At the conclusion of the active treatment regimen, periodic follow-up evaluation should be provided. Therapeutic lenses may be prescribed in conjunction with optometric vision therapy.

#### **AMBLYOPIA**

Definition-Amblyopia is a developmental disorder of spatial vision characterized by reduced visual acuity and visual information processing.

#### Signs and symptoms

The signs and symptoms associated with amblyopia include, but are not limited to, the following:

1. Reduced vision in one or both eyes
2. Spatial distortion

#### Diagnostic factors

Amblyopia is characterized by one or more of the following diagnostic findings:

1. Reduced acuity in affected eye which does not normalize with refractive prescription
2. Anisometropia
3. Strabismus
4. Bilateral significant refractive errors

5. Inability to maintain stable foveal fixation
6. Suppression of binocular vision
7. Reduced stereopsis
8. Reduced accommodative facility
9. Inefficient ocular motor skills

### Therapeutic considerations

#### A. Management

The doctor of optometry determines the therapeutic modalities and frequency of evaluation and follow-up, based upon the patient's condition and unique needs. The management of the case and duration of the treatment would be affected by:

1. Onset and duration of the problem
2. Other associated anomalies such as anisometropia or strabismus
3. Extent of visual demands placed upon the individual
4. Patient compliance
5. Prior interventions
6. Implications of patient's general health and associated visual condition

#### B. Treatment

Early detection and intervention maximizes the probability of success in the treatment of amblyopia. Some cases are successfully managed by prescription of therapeutic lenses and/or prisms. However, most amblyopia requires optometric vision therapy.

Optometric vision therapy usually incorporates the prescription of specific treatments in order to:

1. Compensate for isometropia, anisometropia and its amblyogenic influences
2. Stabilize central foveal fixation
3. Normalize visual acuity
4. Normalize monocular skills, including but not limited to, oculomotor, accommodative and reaction time
5. Minimize spatial distortion
6. Minimize suppression
7. Minimize strabismus
8. Normalize binocular function

### Duration of treatment

The required duration of treatment depends upon the severity and/or complexity of the problem.

1. The most commonly encountered amblyopia usually requires 28 to 40 hours of office therapy.
2. Amblyopia complicated by:
  - a. associated visual adaptations (e.g., anomalous correspondence, eccentric fixation, spatial distortion) require additional office therapy.
  - b. associated visual anomalies (e.g., strabismus, nystagmus, cataract) require additional office therapy.
  - c. associated conditions such as neurodevelopmental anomalies require substantially more office therapy.



### Follow-up care

At the conclusion of the active treatment regimen, periodic follow-up evaluation should be provided. Therapeutic lenses may be used for the maintenance of long-term stability. Some cases may require additional therapy due to decompensation.

### **BINOCULAR VISION DISORDERS**

Definition-Non-strabismic sensorimotor anomalies characterized by the inability to efficiently, accurately, and/or comfortably sustain binocular vision, not otherwise classified.

### Signs and symptoms

The signs and symptoms associated with unspecified binocular vision disorder are often related to visually demanding tasks and/or making spatial judgments. They may include, but are not limited to, the following:

1. Asthenopia
2. Headache
3. Pain in or around the eye
4. Difficulty sustaining attention during visually demanding tasks
5. Diplopia (double vision)
6. Abnormal postural adaptation/abnormal working distance
7. General fatigue
8. Inaccurate depth judgment or stereopsis
9. Dizziness after sustained tasks
10. Muscular incoordination/clumsiness
11. Motion sickness: initial encounter

### Diagnostic factors

General binocular vision dysfunction is characterized by one or more of the following diagnostic findings:

1. Restricted or imbalanced vergence ranges
2. Asthenopia/vertigo responses during testing
3. Suppression of binocular vision
4. Defective stereopsis
5. Abnormal accommodative – convergence relationship

### Therapeutic considerations

#### A. Management

The doctor of optometry determines appropriate diagnostic and therapeutic modalities, and frequency of evaluation and follow-up, based upon the urgency and nature of the patient's condition and unique needs. The management of the case and duration of treatment would be affected by:

1. The severity of symptoms and diagnostic factors including onset and duration of the problem
2. Implications of patient's general health and associated visual conditions
3. Extent of visual demands placed upon the individual
4. Patient compliance
5. Prior interventions

## B. Treatment

A number of cases are successfully managed by prescription of therapeutic lenses or prisms. However, most general binocular vision dysfunctions require optometric vision therapy to optimize visual comfort and efficiency. Optometric vision therapy usually incorporates the prescription of specific treatments in order to:

1. Minimize suppression
2. Develop adequate fusional ranges
3. Develop adequate vergence facility
4. Normalize depth judgment and/or stereopsis
5. Normalize accommodative/convergence relationship

### Duration of treatment

The required duration of treatment is commensurate with the severity and/or complexity of the problem.

1. Binocular vision disorder, unspecified usually requires a minimum of 12 hours of office therapy.
2. General binocular vision dysfunction complicated by:
  - a. suppression: up to an additional 8 hours of office therapy
  - b. diminished stereopsis: up to an additional 8 hours of office therapy
  - c. other diagnosed vision anomalies, such as ocular motor dysfunction and accommodative disorder: may require additional therapy
  - d. associated conditions such as stroke, head trauma, or other systemic conditions: may require substantially more office therapy.

### Follow-up care

At the conclusion of the active treatment regimen, periodic follow-up evaluation should be provided.

### **CONVERGENCE EXCESS**

Definition-A sensorimotor anomaly of the binocular vision system, characterized by a tendency for the eyes to over-converge at near.

### Signs and symptoms

The signs and symptoms associated with convergence excess are often related to prolonged, visually-demanding, near centered tasks such as reading. They may include, but are not limited to, the following:

1. Asthenopia
2. Headache
3. Avoidance of or inability to sustain near visual task
4. Diplopia
5. Transient blurred vision
6. Abnormal postural adaptation/abnormal working distance
7. Pain in or around the eye
8. Abnormal fatigue
9. Difficulty sustaining attention during visually demanding tasks
10. Dizziness

### Diagnostic factors

In addition to greater esophoria at near than at distance, convergence excess is characterized by one or more of the following diagnostic findings:

1. High AC/A ratio
2. Low negative or excessive positive fusional vergence ranges
3. Reduced positive relative accommodation (PRA)
4. Eso-fixation disparity with higher than normal associated phoria
5. Inadequate binocular accommodative facility
6. More esophoria at near than far

### Therapeutic considerations

#### A. Management

The doctor of optometry determines appropriate diagnostic and therapeutic modalities, and frequency of evaluation and follow-up, based upon the urgency and nature of the patient's condition and unique needs. The management of the case and duration of the treatment would be affected by:

1. The severity of symptoms and diagnostic factors including onset and duration of the problem
2. Implications of patient's general health and associated visual conditions
3. Extent of visual demands placed upon the individual
4. Patient compliance
5. Prior interventions

#### B. Treatment

Convergence excess is often successfully managed by prescription of therapeutic lenses and/or prisms. However, optometric vision therapy may also be required. Optometric vision therapy usually incorporates the prescription of specific treatments in order to:

1. Normalize associated deficiencies in ocular motor control and accommodation
2. Normalize accommodative/convergence relationship
3. Normalize fusional vergence ranges and facility
4. Reduce or eliminate suppression (reduce or eliminate)
5. Normalize depth judgment and/or stereopsis
6. Integrate binocular function with information processing

### Duration of treatment

The required duration of treatment is extended commensurate with the severity and/or complexity of the problem. Treatment duration will depend upon the particular patient's condition and associated circumstances. When duration of treatment beyond these ranges is required, documentation of the medical necessity for additional treatment services may be warranted.

1. Convergence excess usually requires a minimum of 18 hours of office therapy.
2. Convergence excess complicated by:
  - a. Oculomotor dysfunction: up to an additional 18 hours of office therapy
  - b. An associated accommodative disorder: up to an additional 8 hours of office therapy

- c. Other diagnosed vision anomalies such as ocular motor dysfunction and accommodative disorder may require additional therapy
- d. Associated conditions such as stroke, head trauma, or other systemic diseases: may require substantially more office therapy.

#### Follow-up care

At the conclusion of the active treatment regimen, periodic follow-up evaluation should be provided. Therapeutic lenses may be utilized for maintenance of long-term stability.

### **CONVERGENCE INSUFFICIENCY**

Definition-An anomaly of the binocular vision system, characterized by a tendency for the eyes to underconverge at near.

#### Signs and symptoms

The signs and symptoms associated with convergence insufficiency are often related to prolonged, visually-demanding, near centered tasks such as reading. They may include, but are not limited to, the following:

1. Diplopia
2. Asthenopia
3. Transient blurred vision
4. Difficulty sustaining attention to near point tasks
5. Abnormal fatigue
6. Headache
7. Pain in or around the eye
8. Abnormal postural adaptation/abnormal working distance
9. Dizziness

#### Diagnostic factors

Convergence insufficiency is characterized by one or more of the following diagnostic findings:

1. High exophoria at near
2. More exophoria at near than far
3. Low Accommodative-Convergence/Accommodation ratio
4. Reduced near-point of convergence
5. Low fusional vergence ranges and/or facility
6. Exo-fixation disparity with steep forced vergence slope

#### Therapeutic considerations

##### A. Management

The doctor of optometry determines the therapeutic modalities, and frequency of evaluation and follow-up, based upon the patient's condition and unique needs. The management of the case and duration of treatment would be affected by:

1. The severity of symptoms and diagnostic factors including onset and duration of the problem
2. Implications of patient's general health and associated visual conditions
3. Extent of visual demands placed upon the individual
4. Patient compliance

5. Prior interventions

## B. Treatment

1. Normalize the near-point of convergence
2. Normalize fusional vergence ranges and facility
3. Minimize suppression
4. Normalize associated deficiencies in ocular motor control and accommodation
5. Normalize accommodative/convergence relationship
6. Normalize depth judgment and/or stereopsis
7. Integrate binocular function with information processing

### Duration of treatment

The required duration of treatment is commensurate with the severity and/or complexity of the problem.

1. Convergence insufficiency usually requires a minimum of 12 hours of office therapy.
2. Convergence insufficiency complicated by:
  - a. restricted fusional ranges: up to an additional 12 hours of office therapy.
  - b. suppression: up to an additional 6 hours of office therapy.
  - c. an accommodative element: up to an additional 8 hours of office therapy.
  - d. other diagnosed vision anomalies such as ocular motor dysfunction and accommodative disorder: may require additional therapy.
  - e. associated conditions such as stroke, head trauma, or other systemic diseases: may require substantially more office therapy.

### Follow-up care

At the conclusion of the active treatment regimen, periodic follow-up evaluation should be provided. Therapeutic lenses may be prescribed in conjunction with optometric vision therapy.

## **OCULAR MOTOR DYSFUNCTION**

- Deficiencies of saccadic eye movements
- Deficiencies of smooth pursuit movements
- Nystagmus

Definition-A sensorimotor anomaly of the ocular motor system where the characteristic feature is the inability to perform accurate and effective ocular pursuits, saccades, and fixations.

### Signs and symptoms

The signs and symptoms associated with ocular motor dysfunction are related to visually-demanding tasks. They may include, but are not limited to, the following:

1. Loss of place and/or omission of words when reading
2. Difficulty visually tracking and/or following objects
3. Poor academic performance
4. Reduced efficiency and productivity
5. Poor attention span/easy distractibility

6. Muscular incoordination
7. Vertigo
8. Motion Sickness

#### Diagnostic factors

Ocular motor dysfunction is characterized by one or more of the following diagnostic findings:

1. Reduced accuracy of ocular pursuits and/or saccades
2. Difficulty separating head/body and eye movements
3. Difficulty sustaining adequate pursuit or saccadic eye movement under cognitive demands
4. Inability to follow targets in proper sequence
5. Need for tactile/kinesthetic reinforcement while performing ocular motor activities
6. Inability to adequately sustain fixation/erratic fixations
7. Increased time required to perform tasks dependent upon saccadic eye movements

#### Therapeutic considerations

##### A. Management

The doctor of optometry determines appropriate diagnostic and therapeutic modalities, and frequency of evaluation and follow-up, based upon the urgency and nature of the patient's condition and unique needs. The management of the case and duration of treatment would be affected by:

1. The severity of symptoms and diagnostic factors including onset and duration of the problem
2. Implications of patient's general health and associated visual conditions
3. Extent of visual demands placed upon the individual
4. Patient compliance
5. Prior interventions

##### B. Treatment

The treatment of most ocular motor dysfunctions requires orthoptics/vision therapy. However, the therapy regimen may be augmented by the use of therapeutic lenses or prisms. Optometric vision therapy usually incorporates the prescription of specific treatments in order to:

1. Develop accurate fixation skills
2. Develop accurate ocular pursuits and saccades
3. Integrate ocular motor skills with accurate motor response
4. Integrate ocular motor skills with other sensory skills (vestibular, kinesthetic, tactile, auditory)
5. Integrate ocular motor skills with vergence and accommodative systems
6. Integrate ocular motor skills with information processing

#### Duration of treatment

The required duration of treatment is commensurate with the severity and/or complexity of the problem.

1. The most commonly encountered ocular motor dysfunction usually requires a minimum of 12 hours of office therapy in addition to therapy provided for concurrent conditions.
2. Ocular motor dysfunction complicated by accommodative-convergence disorders usually require up to an additional 16 hours of office therapy.

3. Ocular motor dysfunction complicated by associated conditions such as stroke, head trauma or other systemic conditions require substantially more office therapy.

#### Follow-up care

At the conclusion of the active treatment regimen, periodic follow-up evaluations should be provided.

#### **STRABISMUS**

Definition-A sensorimotor anomaly of binocular integration resulting in the failure to maintain bifoveal alignment manifesting in a divergent (exotropia), convergent (esotropia), cyclo or vertical deviation of the non-fixating eye.

#### Signs and symptoms

The signs and symptoms associated with strabismus include, but are not limited to, the following:

1. Intermittent or constant eye turn
2. Double vision
3. Poor spatial judgment
4. Head tilt/turn
5. Closing or covering one eye

#### Diagnostic factors

Strabismus is characterized by one or more of the following diagnostic findings:

1. Manifest angle of eye deviation
2. Deficient vergence abilities, reduced ranges of fusion with poor depth perception/stereopsis
3. Diplopia
4. Sensory adaptations e.g. suppression  
amblyopia unspecified  
anomalous correspondence
5. Frequency
6. Comitance
7. Onset

#### Therapeutic considerations

##### A. Management

The doctor of optometry determines appropriate diagnostic and therapeutic modalities, and frequency of evaluation and follow-up, based upon the urgency and nature of the patient's condition and unique needs. The management of the case and duration of treatment is affected by:

1. The severity of symptoms and diagnostic factors including onset and duration of the problem
2. Implications of patient's general health and considerations of disease factors
3. Associated visual conditions
4. Extent of visual demands placed upon the individual
5. Patient compliance
6. Prior interventions

## B. Treatment

Some cases of strabismus can be successfully managed by prescription of therapeutic lenses or prisms. However, most patients with strabismus require optometric vision therapy. Optometric vision therapy usually incorporates the prescription of specific treatments in order to:

1. Normalize ocular motor control
2. Normalize spatial localization skills
3. Normalize accommodative abilities
4. Eliminate sensory adaptations
5. Establish fusion response at all distances and in all fields of movement
6. Normalize accommodative/convergence relationship
7. Integrate oculomotor function with information processing

### Duration of treatment

The required duration of treatment is extended commensurate with the severity and/or complexity of the problem.

1. Basic intermittent exotropia or esotropia usually requires a minimum of 40 hours of office therapy.
2. Basic constant exotropia or esotropia usually requires a minimum of 60 hours of office therapy.
3. Exotropia or esotropia complicated by any of the following requires additional office therapy:
  - a. visual adaptations (e.g., amblyopia, anomalous correspondence, suppression)
  - b. visual anomalies (e.g., cyclotropia, hypertropia)
  - c. factors such as stroke, head trauma, paresis, strabismus surgery

### Follow-up care

At the conclusion of the active treatment regimen, periodic follow-up evaluations should be provided. Therapeutic lenses may be prescribed at the conclusion of optometric vision therapy for maintenance of long-term stability. Some cases may require additional therapy due to decompensation.

## **DISORDERS OF HIGHER VISUAL FUNCTION/VISUAL PROCESSING**

Developmental reading disorder/dyslexia  
Developmental visual processing disorder  
Developmental visual motor delay  
Acquired reading disorder/alexia  
Abnormal visual evoked potential  
Visual cortex disorder/vascular  
Homonymous hemianopia

Definition-Brain mediated deficits in visual function, visual processing, and/or visual integration

### Signs and symptoms

The signs and symptoms associated with disorders of higher visual function/processing may be developmental in children or acquired due to brain injury at any age. They may include, but are not limited to, the following:

1. Difficulty with reading
2. Poor coordination



3. Poor academic performance
4. Poor attention span/easy distractibility
5. Reduced efficiency and productivity
6. Impaired orientation and mobility

#### Diagnostic factors

Disorder of higher visual function/visual processing are characterized by one or more of the following diagnostic findings:

1. Impaired visual integration
2. Poor visual perceptual skills
3. Poor visual processing with cognitive demands
4. Increased time required to perform tasks dependent upon visual processing
5. Delays in visual evoked potential implicit time/latency
6. Visual field defects

#### Therapeutic considerations

##### A. Management

The doctor of optometry determines appropriate diagnostic and therapeutic modalities, and frequency of evaluation and follow-up, based upon the urgency and nature of the patient's condition and unique needs. The management of the case and duration of treatment would be affected by:

1. The severity of symptoms and diagnostic factors including onset and duration of the problem
2. Implications of patient's general health and associated visual conditions
3. Extent of visual demands placed upon the individual
4. Patient compliance
5. Prior interventions

##### B. Treatment

The treatment of most abnormalities of higher visual function/visual processing requires vision therapy. However, the therapy regimen may be augmented by the use of therapeutic lenses or prisms. Optometric vision therapy usually incorporates the prescription of specific treatments in order to:

1. Develop/habilitate or rehabilitate accurate visual identification
2. Develop/habilitate or rehabilitate visual memory, sequencing or other visual perceptual skills
3. Integrate vision with other sensory-motor-cognitive systems
4. Integrate visual information processing with ocular motor skills
5. Develop/habilitate or rehabilitate reading readiness involving vision
6. Develop/habilitate or rehabilitate driving readiness skills involving vision

#### Duration of treatment

The required duration of treatment is commensurate with the severity and/or complexity of the problem.

1. The most commonly encountered disorders of higher visual function/visual processing usually requires a minimum of 24 hours of office therapy in addition to any therapy provided for

concurrent conditions.

2. Disorders complicated by developmental conditions presenting multiple handicaps such as cerebral palsy and autism spectrum disorder may require substantially more therapy.
3. Disorders associated with conditions such as stroke or head trauma often require substantially more therapy.

#### Follow-up care

Periodic re-assessment of the use of lenses or prisms is essential. Monitoring of progress through evaluations is recommended due to the complexity of these conditions. At the conclusion of the active treatment regimen, follow-up evaluations should be provided.

#### D) Predetermination of Coverage 92065 (FCOVD)

---

<Date>

<Insurance company name>

<Address>

Re: <Patient Name>

<DOB>

<ID#>

<Group#>

<Subscriber Name>

Attention: Predetermination of Benefits Department:

I am writing regarding a pre-determination of benefits for in-network *medical* coverage for CPT Procedure Code (92065) for <patient name>. <Patient name>'s comprehensive testing was performed on <date> and revealed the following diagnosis codes: <fill in codes>. These diagnoses relate to the nerves and muscles of the vision system, *not* to routine vision services. Surgery is usually not indicated for these conditions and specifically not indicated for this particular patient.

I am one of <#> board certified *developmental* optometrists in <state>; my specialty is treating individuals who suffer from visual skills deficiencies related to the *nerves and muscles* of the vision system. My specialty involves providing functional visual evaluations and treatment for qualifying patients as a viable medical alternative to possible costly surgical procedures.

**NOTE: THE TREATMENT FOR THE ABOVE PROBLEMS IS MEDICALLY NECESSARY AND IS REFERRED TO AS ORTHOPTIC THERAPY (92065). THE TREATMENT IS SPECIFIC FOR THESE VISUAL NEUROMUSCULAR ANOMALIES AND IS BEING DONE TO CORRECT THE ABOVE CONDITIONS.**

Vision therapy is a fully organized therapeutic process utilized to treat visual efficiency and/or visual perceptual problems that cannot be treated with glasses alone. The treatment is complex, involving sophisticated instrumentation, visual therapy exercises, and computers that developmental optometrists have been trained extensively and are certified to perform. The specific activities and instrumentation are determined by the nature and severity of the condition. The frequency and duration of treatments are dictated by the individual's situation. In <Patient name>'s case, I feel that *approximately* <#> in-office weekly therapy treatment sessions will be required; he plans to begin this therapy process in <date>.

The patient has requested a pre-determination of benefits. If I can be of further service, please do not hesitate to call me.

Sincerely,

<Doctor Name>

E) Predetermination of Coverage 92065 (non-FCOVD)

---

<Date>

<Insurance company name>

<Address>

Re: <Patient Name>

<DOB>

<ID#>

<Group#>

<Subscriber Name>

Attention: Predetermination of Benefits Department:

I am writing regarding a pre-determination of benefits for in-network *medical* coverage for CPT Procedure Code (92065) for <patient name>. <Patient name>'s comprehensive testing was performed on <date> and revealed the following diagnosis codes: <fill in codes>. These diagnoses relate to the nerves and muscles of the vision system, *not* to routine vision services. Surgery is usually not indicated for these conditions and specifically not indicated for this particular patient.

I am one of thousands of optometrists trained in treating individuals who suffer from visual skills deficiencies related to the *nerves and muscles* of the vision system. My specialty involves providing functional vision evaluation and treatment for qualifying patients as a viable medical alternative to possible costly surgical procedures.

NOTE: THE TREATMENT FOR THE ABOVE PROBLEMS IS MEDICALLY NECESSARY AND IS REFERRED TO AS ORTHOPTIC THERAPY (92065). THE TREATMENT IS SPECIFIC FOR THESE VISUAL NEUROMUSCULAR ANOMALIES AND IS BEING DONE TO CORRECT THE ABOVE CONDITIONS.

Vision therapy is a fully organized therapeutic process utilized to treat visual efficiency and/or visual perceptual problems that cannot be treated with glasses alone. The treatment is complex, involving sophisticated instrumentation, visual therapy exercises, and computers that developmental optometrists have been trained extensively and are certified to perform. The specific activities and instrumentation are determined by the nature and severity of the condition. The frequency and duration of treatments are dictated by the individual's situation. In <Patient name>'s case, I feel that *approximately* <#> in-office weekly therapy treatment sessions will be required; he plans to begin this therapy process in <date>.

The patient has requested a pre-determination of benefits. If I can be of further service, please do not hesitate to call me.

Sincerely,  
<Doctor Name>

**F) Pre-Authorization Request Any CPT Code**

---

<Date>

<Insurance company name>

<Address>

Re: <Patient Name>

<DOB>

<ID#>

<Group#>

<Subscriber Name>

Diagnosis: ICD-10 <fill>

CPT <fill> is medically necessary to correct this diagnosed condition or as an alternative to surgery. All information needed to process this claim appears on this form. If additional information is required, please request such in writing.

This is a pre-authorization request for \_\_\_\_\_ sessions of CPT \_\_\_\_\_ to manage ICD-10 \_\_\_\_\_.

Please furnish the following information:

1. Is this a covered benefit?
2. What percentage do you pay?
3. Has the deductible been met?
4. Will payment be made directly to the provider or the subscriber?

Sincerely,

Dr. <name>

G) Letter for Request of Additional Information CPT 92065 (FCOVD)

---

<Date>

<Insurance company name>

<Address>

Re: <Patient Name>

<DOB>

<ID#>

<Group#>

<Subscriber Name>

Medical Coverage for CPT Procedure Code 92065

I am sending you the additional information you requested regarding medical coverage for <Patient Name> for procedure code 92065 (orthoptic therapy). The patient's comprehensive examination, performed on <Date>, revealed the following Dx codes: **<fill in codes>**.

The treatment for the above problems began on <date>. The patient's prognosis is good, with approximately **<fill in number>** therapy sessions recommended. The patient has completed **<fill in number>** of these therapies and has shown great progress. These are therapeutic services and are not connected, in any way, with routine eye care or refractive conditions.

<Patient's name>'s diagnoses codes, along with the progress he has already achieved through therapy, certainly indicate orthoptic therapy is an appropriate medical procedure to follow. I am one of **<fill in number>** board certified optometrists in the state of **<fill in state>** and my specialty is working with children, youth, and adults like <Patient's name> who suffer from visual efficiency/perceptual skills deficiencies.

If you need additional information, please do not hesitate to call me.

Sincerely,

Dr. <name>

H) Letter for Request of Additional Information CPT 92065 (non-FCOVD)

---

<Date>

<Insurance company name>

<Address>

Re: <Patient Name>

<DOB>

<ID#>

<Group#>

<Subscriber Name>

Medical Coverage for CPT Procedure Code 92065

I am sending you the additional information you requested regarding medical coverage for <Patient Name> for procedure code 92065 (orthoptic therapy). The patient's comprehensive examination, performed on <Date>, revealed the following Dx codes: **<fill in codes>**.

The treatment for the above problems began on <date>. The patient's prognosis is good, with approximately **<fill in number>** therapy sessions recommended. The patient has completed **<fill in number>** of these therapies and has shown great progress. These are therapeutic services and are not connected, in any way, with routine eye care or refractive conditions.

<Patient's name>'s diagnoses codes, along with the progress he has already achieved through therapy, certainly indicate orthoptic therapy is an appropriate medical procedure to follow. I am one of thousands of optometrists trained in working with children, youth, and adults like <Patient's name> who suffer from visual skills deficiencies.

If you need additional information, please do not hesitate to call me.

Sincerely,

Dr. <name>

l) Letter for Request of Additional Information CPT 97XXX (FCOVD)

---

<Date>

<Insurance company name>

<Address>

Re: <Patient Name>

<DOB>

<ID#>

<Group#>

<Subscriber Name>

Medical Coverage for **Procedure Code <fill>**

I am sending you the additional information you requested regarding medical coverage for <Patient Name> for procedure code <fill in code>. The patient's comprehensive examination, performed on <Date>, revealed the following Dx codes: <fill in codes>.

Neurobehavioral testing CPT <fill in E&M or 961XX> was performed on <Date>, which revealed additional deficiencies in the visual cognitive skills areas of <fill in deficient areas>.

The treatment for the above problems began on <date>. The patient's prognosis is good, with approximately <fill in number> therapy sessions recommended. The patient has completed <fill in number> of these therapies and has shown great progress. These are therapeutic services and are not connected, in any way, with routine eye care or refractive conditions.

<Patient's name>'s diagnoses codes, along with the progress they have already achieved through therapy, certainly indicate orthoptic therapy is an appropriate medical procedure to follow. I am one of <fill in number> board certified optometrists in the state of <fill in state> and my specialty is working with children, youth, and adults like <Patient's name> who suffer from visual efficiency/perceptual skills deficiencies.

If you need additional information, please do not hesitate to call me.

Sincerely,

Dr. <name>



J) Letter for Request of Additional Information CPT 97XXX (non-FCOVD)

---

<Date>

<Insurance company name>

<Address>

Re: <Patient Name>

<DOB>

<ID#>

<Group#>

<Subscriber Name>

Medical Coverage for **Procedure Code <fill>**

I am sending you the additional information you requested regarding medical coverage for <Patient Name> for procedure code <fill in code>. The patient's comprehensive examination, performed on <Date>, revealed the following Dx codes: <fill in codes>.

Neurobehavioral testing CPT <fill in E&M or 961XX> performed on <Date>, revealed additional deficiencies in the visual cognitive skills areas of <fill in deficient areas>.

The treatment for the above problems began on <date>. The patient's prognosis is good, with approximately <fill in number> recommended therapy sessions. The patient has completed <fill in number> of these therapies and has shown great progress. These are therapeutic services and are not connected, in any way, with routine eye care or refractive conditions.

<Patient's name>'s diagnoses codes, along with the progress they have already achieved through therapy, certainly indicate orthoptic therapy is an appropriate medical procedure to follow. I am one of thousands of optometrists trained in working with children, youth, and adults like <Patient's name> who suffer from visual efficiency/perceptual skills deficiencies.

If you need additional information, please do not hesitate to call me.

Sincerely,

Dr. <name>

K) Letter for Denied Claim

---

<Date>

<Insurance company name>

<Address>

Re: <Patient Name>

<DOB>

<ID#>

<Group#>

<Subscriber Name>

Dear Medical Review:

I am writing in response to your claim denial for <Patient name and ID #> for **Procedure Code 92065 (orthoptic therapy)**. The **diagnoses codes**, established by the sensorimotor exam conducted on <Date>, are: <fill in codes>.

**NOTE: THE TREATMENT FOR THE ABOVE PROBLEMS IS MEDICALLY NECESSARY AND IS REFERRED TO AS ORTHOPTIC THERAPY. THE TREATMENT IS SPECIFIC FOR THE VISUAL NEUROMUSCULAR ANOMALIES AND IS BEING DONE TO CORRECT THE ABOVE CONDITIONS AND IS NOT CONNECTED IN ANY WAY WITH ROUTINE EYE CARE, REFRACTIVE ERROR, OR GLASSES.**

Orthoptic therapy is a fully organized therapeutic regiment utilized to treat a visual efficiency problem that cannot be treated with glasses alone. The treatment is complex, involving sophisticated instrumentation and computers that **behavioral optometrists** have been trained extensively and are **board certified to perform**. The specific activities and instrumentation are determined by the nature and severity of the condition. The frequency and duration of treatments are dictated by the individual's situation. In <Patient Name>'s case, <fill in number> therapeutic sessions were needed to correct the problems.

If I can be of further service, please do not hesitate to contact me.

Sincerely,

<Doctor Name>

## L) Letter for Additional Sessions

---

<Date>

<Insurance company name>

<Address>

Re: <Patient Name>

<DOB>

<ID#>

<Group#>

<Subscriber Name>

Thank you for your approval of <number> orthoptic therapy visits for **<patient name, ID number and claim #>**. The patient has completed this program and showed excellent progress. However, because of the number and severity of visual efficiency problems <patient name> had, in order for the patient to receive the maximum benefit from this vision therapy procedure, a minimum of <number> sessions has been a necessity. Thus, we are requesting coverage for additional <number> sessions for <patient name>.

I feel the positive testing results more than justify payment for these additional therapy sessions <patient name> completed. Thank you for providing coverage for a therapy program that can make such a positive difference in a child's life.

Sincerely,

<Doctor Name>

## M) Letter Explaining Difference between Sensorimotor Exam vs. Eye Examination

---

<Date>

<Insurance company name>

<Address>

Re:<Patient Name>:

<DOB>:

<ID#>:

<Group #>:

<Subscriber Name>:

Dear Medical Review:

A sensorimotor examination (Procedure Code 92060) was performed on <Patient Name> in my office on <date>. A sensorimotor exam is not a vision exam; it is a medical diagnostic exam. A sensorimotor exam has been covered under medical insurance. This exam involves a group of tests that determines what problems, if any, exist with the nerves and muscles of the visual system. It is this exam that enables the doctor to render diagnosis codes, a prognosis, and to recommend a treatment modality, if such a plan is warranted. It is not to determine if the patient needs a refractive prescription. A sensorimotor exam involves numerous tests *not* performed in a comprehensive general ophthalmologic eye exam. <Patient Name>'s exam revealed the following diagnosis codes: <list>.

Thus, this sensorimotor exam should be covered under their *medical* insurance. Thank you for making this correction in your insurance records. If I can be of further service, please do not hesitate to contact me.

Sincerely,

<Doctor Name>

**N) Explanation of Patient's Responsibility with Insurance Coverage (Non Participating Physicians)**

---

**Attention to All Patients**

Due to the constant change in insurance company policies, we are asking for your help. Please read the following information carefully:

Patients are responsible for knowing the following:

- What percentage your insurance company pays and any deductible due.
- If your insurance plan requires a referral from your primary care physician, you are responsible for obtaining this prior to your visit.
- If your claim is to be billed to your medical insurance or your vision insurance.
- Whether or not your insurance requires that you receive care from a specific provider.

Time does not allow our staff to obtain the above information for you. We will approximate the amount you owe the day of your visit with the understanding that the patient is responsible for the entire balance. We will not be responsible for problems or discrepancies, this must be handled by the insured, but we will be happy to assist you in any way that we can. We will provide you with any information needed to assist with the resolution of any problem that may occur with your carrier. If you have any questions pertaining to our policy, feel free to consult with our staff regarding your concerns or questions.

I, the undersigned, have read and understand the above information regarding the insurance policy of this office.

\_\_\_\_\_ Signature of Patient (Parent if minor)

Date \_\_\_\_\_

## O) Explanation of Patient's Responsibility with Insurance Coverage (Denial Review)

---

### Insurance Coverage for Vision Therapy

Vision therapy is used to treat diagnosed vision conditions. In some cases, vision therapy is the only available and effective treatment option for these conditions. This treatment may be covered under major medical insurance plans. However, some insurance companies and managed care plans may deny or place severe limits on coverage for Vision Therapy services.

Under all forms of medical insurance plans, you, the consumer and/or patient, have a right to request a review of any service that is denied coverage, or for which coverage is severely limited. If you believe your plan has incorrectly evaluated the claim for coverage, acted arbitrarily, or discriminated unfairly in determining coverage, you could consider requesting a review.

#### Steps to consider in requesting a review of denial of coverage for vision therapy

1. First, review your medical plan's explanation of benefits booklet to see if there is any statement about the inclusion or exclusion of coverage for vision therapy. Some plans explicitly exclude coverage for these services.  
Some plans may exclude coverage for vision therapy to treat educational problems such as learning disabilities, dyslexia, etc. The treatment of learning problems and dyslexia are educational problems that are not within the purview of major medical insurance coverage. However, this should not preclude receiving coverage for vision therapy which is treatment of a diagnosed vision problem.
2. Ask for a written statement on the exact reason that coverage was denied or limited. If an arbitrary statement is given that the company or plan concluded that vision therapy is not considered medically necessary, or is not effective in treating the diagnosed problem, ask for documentation to support that claim.  
Many research studies and clinical reports have been published that support the effectiveness of vision therapy. Unfortunately, your insurance company or plan may not have reviewed this information.
3. Some insurance plans may indicate that the services were reviewed by their "medical consultant" who recommended the services not be covered. You may wish to inquire as to the qualifications of the consultant, especially in regard to the area of determination (i.e., was it a Doctor of Optometry or O.D.?).  
It is common medical practice for questions regarding the medical necessity or appropriateness of treatment to be reviewed by a "medical peer," another doctor with similar training and knowledge in the particular area of care. If the claim for vision therapy services was not reviewed by an optometrist who also provides these services, then true "peer review" did not occur.
4. When claims are denied on the basis that the insurance company or their consultant believes there is a lack of sufficient research to support the effectiveness of vision therapy, supplying documentation of available research may result in approval of coverage.
5. If after going through the above process, coverage of your claim for vision therapy is still denied, you may want to consider the following actions:

- If your medical insurance coverage is provided by your employer, bring the problem to the attention of your company's employment benefits manager and ask for his or her assistance.
- If you purchase insurance coverage yourself, contact your insurance agent and ask for help in getting your claim paid.
- If you are unable to obtain satisfactory resolution of your claim, you could consider filing a complaint with the office of your state commissioner of insurance.

It is important to remember that the unwillingness of your insurance company to pay for these services does not reduce the need for obtaining treatment. Talk with your doctor about payment options that may be available to assist you or your family in obtaining needed care.

P) **Alternative Sample Insurance Coverage Form**

---

<Date>

<Insurance company name>

<Address>

Re: <Patient Name>

<DOB>

<ID#>

<Group#>

<Subscriber Name>

To Whom It May Concern:

<Patient Name> was recently examined in my office on <exam date>. The diagnostic examination revealed the following medical diagnosis: <ICD-10>.

NOTE: The treatment for the above condition is **medically necessary** and is referred to as visual therapy. The treatment is specific for **neuromuscular anomaly** and is being done to correct the above condition or as an alternative to surgery and is not connected in any way with routine eye care, refractive error or glasses.

**Specific treatment program**

The treatment program for <ICD-10> requires a minimum of <#> visits and is divided into several phases.

- Phase I: Designed to restore normal positive fusional skills and ocular pursuits and saccades, and to integrate pursuits and saccades with other ocular motor skills, as well as to restore normal positive and fusional vergence amplitudes, near point of convergence and accommodative amplitude.
- Phase II: Designed to integrate ocular motor skills with accurate motor responses and with sensory skills, as well as to normalize fusional facility in both the positive and negative fusional vergence systems with no suppression.
- Phase III: Designed to integrate ocular motor skills with vergence and accommodative systems and with information processing, as well as to create excessive in both the accommodative and fusional systems, and to restore normal vergence facility and amplitude during sustained versions.

Each of these three phases generally requires a minimum of <number> visits. Sessions are weekly or bi-weekly and last <#> minutes. All therapy is under the direct supervision of (Doctor name).

Thank you for your consideration. If you have any questions, please contact me.

Sincerely,

<Doctor Name>



## Q) Position Statements on Optometric Vision Therapy

### Vision Therapy Information for Health Care and Other Allied Professionals

#### A Joint Organizational Policy Statement of the American Academy of Optometry and the American Optometric Association

##### Introduction

Society places a premium on efficient vision. Schools and most occupations require increasing amounts of printed and computer information to be handled accurately and in shorter periods of time. Vision is also a major factor in sports, crafts, and other pastimes. The efficiency of our visual system influences how we collect and process information. Repetitive demands on the visual system tend to create problems in susceptible individuals. Inefficient vision may cause an individual to slow down, be less accurate, experience excessive fatigue, or make errors. When these types of signs and symptoms appear, the individual's conscious attention to the visual process is required. This, in turn, may interfere with speed, accuracy, and comprehension of visual tasks. Many of these visual dysfunctions are effectively treated with vision therapy.

##### Pertinent issues

Vision is a product of our inherited potentials, our past experiences, and current information. Efficient visual functioning enables us to understand the world around us better and to guide our actions accurately and quickly. Age is not a deterrent to the achievement of successful vision therapy outcomes.

Vision is the dominant sense and is composed of three areas of function:

1. Visual pathway integrity including eye health, visual acuity, and refractive status.
2. Visual skills including accommodation (eye focusing), binocular vision (eye teaming), and eye movements (eye tracking).
3. Visual information processing including identification, discrimination, spatial awareness, and integration with other senses.

Learning to read and reading for information require efficient visual abilities. The eyes must team precisely, focus clearly, and track quickly and accurately across the page. These processes must be coordinated with the perceptual and memory aspects of vision, which in turn must combine with linguistic processing for comprehension. To provide reliable information, this must occur with precise timing. Inefficient or poorly developed vision requires individuals to divide their attention between the task and the involved visual abilities. Some individuals have symptoms such as headaches, fatigue, eyestrain, errors, loss of place, and difficulty sustaining attention. Others may have an absence of symptoms due to the avoidance of visually demanding tasks.

##### Vision therapy

The human visual system is complex. The problems that can develop in our visual system require a variety of treatment options. Many visual conditions can be treated effectively with spectacles or contact lenses alone; however, some are most effectively treated with vision therapy.

Vision therapy is a sequence of neurosensory and neuromuscular activities individually prescribed and monitored by the doctor to develop, rehabilitate and enhance visual skills and processing. The vision therapy program is based on the results of a comprehensive eye examination or consultation and takes into consideration the results of standardized tests, the needs of the patient, and the patient's signs and symptoms. The use of lenses, prisms, filters, occluders, specialized instruments and computer programs is an integral part of vision therapy. The length of the therapy program varies depending on the severity of the diagnosed conditions, typically ranging from several months to longer periods of time. Activities paralleling in-office techniques are typically taught to the patient to be practiced at home, thereby reinforcing the developing visual skills.

Research has demonstrated vision therapy can be an effective treatment option for:

- Ocular motility dysfunctions (eye movement disorders)
- Non-strabismic binocular disorders (inefficient eye teaming)
- Strabismus (misalignment of the eyes)
- Amblyopia (poorly developed vision)
- Accommodative disorders (focusing problems)
- Visual information processing disorders, including visual-motor integration and integration with other sensory modalities
- Visual sequelae of acquired brain injury

#### Summary

Vision therapy is prescribed to treat diagnosed conditions of the visual system. Effective therapy requires visual skills to be developed until they are integrated with other systems and become automatic, enabling individuals to achieve their full potential. The goals of a prescribed vision therapy treatment regimen are to achieve desired visual outcomes, alleviate the signs and symptoms, meet the patient's needs and improve the patient's quality of life.

This Policy Statement was formulated by a working group representing the American Academy of Optometry, American Optometric Association, the College of Optometrists in Vision Development, and the Optometric Extension Program Foundation. The following individuals are acknowledged for their contributions:

- Gary J. Williams, O.D.; Chair
- Susan A. Cotter, O.D., Louis G. Hoffman, O.D., MS Glen T. Steele, O.D.
- Kelly A. Frantz, O.D., Stephen C. Miller, O.D., Jeffrey L. Weaver, O.D., MS
- Approved by: American Academy of Optometry, May 14, 1999
- American Optometric Association, June 22, 1999 / April 22, 2009
- College of Optometrists in Vision Development, June 25, 1999
- Optometric Extension Program Foundation, June 25, 1999

#### Bibliography

- Bowan MD. Learning disabilities, dyslexia, and vision: a subject review. *Optometry* 2002;73:553-75.
- Caloroso EE, Rouse MW, Cotter SA. Clinical management of strabismus. Boston: Butterworth-Heinemann, 1993.

- Ciuffreda KJ. The scientific basis for and efficacy of optometric vision therapy in nonstrabismic accommodative and vergence disorders. *Optometry* 2002;73:735-62.
- Ciuffreda KJ, Levi DM, Selenow A. *Amblyopia: basic and clinical aspects*. Boston: Butterworth-Heinemann, 1991.
- Ciuffreda KJ, Rutner D, Kapoor N, et al. Vision therapy for oculomotor dysfunctions in acquired brain injury: A retrospective analysis. *Optometry* 2008;79:18-22.
- Ciuffreda KJ, Suchoff IB, Kapoor N et al. Normal visual function. In: Gonzalez EG, Myers SJ, Edelstein JF et al, eds. *Downey and Darling's Physiological Basis of Rehabilitation Medicine*, 3rd edition. Boston: Butterworth-Heinemann, 2001:241-61
- Coffey B, Wick B, Cotter S, et al. Treatment options in intermittent exotropia: a critical appraisal. *Optom Vis Sci* 1992;69:386-404.
- Convergence Insufficiency Treatment Trial Group. Randomized clinical trial of treatments for symptomatic convergence insufficiency in children. *Arch Ophthalmol* 2008;(10):1336-1349.
- Cooper J, Medow N. Intermittent exotropia: basic and divergence excess type. *Binoc Vis Eye Muscle Surg Q* 1993;8:185-216.
- Cooper J, Selenow A, Ciuffreda KJ, et al. Reduction of asthenopia in patients with convergence insufficiency after fusional vergence training. *Am J Optom Physiol Opt* 1983;60:982-9.
- Daugherty KM, Frantz KA, Allison CL, Gabriel HM. Evaluating Changes in Quality of Life after Vision Therapy Using the COVD Quality of Life Outcomes Assessment. *Optom Vis Dev* 2007;38(2):75-81.
- Daum KM. The course and effect of visual training on the vergence system. *Am J Optom Physiol Opt* 1982;59:223-7.
- Fischer B, Hartnegg K. Effects of visual training on saccade control in dyslexia. *Perception* 2000;29:531-542.
- Flax N, Duckman RH. Orthoptic treatment of strabismus. *J Am Optom Assoc* 1978;49:1353-61.
- Garzia RP. Efficacy of vision therapy in amblyopia: a literature review. *Am J Optom Physiol Opt* 1987;64:393-404.
- Griffin JR. Efficacy of vision therapy for nonstrabismic vergence anomalies. *Am J Optom Physiol Opt* 1987;64:411-4.
- Grisham JD, Bowman MC, Owyang LA, Chan CL. Vergence orthoptics: validity and persistence of the training effect. *Optom Vis Sci* 1991;68:441-51.
- Hellerstein LF, Winkler PA. Vestibular dysfunction associated with traumatic brain injury: collaborative and optometry and physical therapy treatment. In: Suchoff IB, et al. eds. *Visual & Vestibular Consequences of Acquired Brain Injury*. Santa Ana, CA: OEP 2002.
- Joint Organizational Policy Statement of the American Academy of Optometry and the American Optometric Association, *Optometric care of the patient with acquired brain injury*. St. Louis, MO, 2002.

- Liu JS, Lee M, Jang J, et al. Objective assessment of accommodation orthoptics. I. Dynamic insufficiency. *Am J Optom Physiol Opt* 1979;56:285-94.
- The 1986/87 Future of Visual Development/Performance Task Force. The efficacy of optometric vision therapy. *J Am Optom Assoc* 1988;59:95-105.
- Optometric clinical practice guideline: care of the patient with accommodative and vergence dysfunction. St. Louis: American Optometric Association, 1999.
- Optometric clinical practice guideline: care of the patient with learning related vision problems. St. Louis: American Optometric Association, 2008
- Optometric clinical practice guideline: care of the patient with strabismus: esotropia and exotropia. St. Louis: American Optometric Association, 2004
- Optometric clinical practice guideline: comprehensive adult eye and vision examination. St. Louis: American Optometric Association, 2005
- Optometric clinical practice guideline: pediatric eye and vision examination. St. Louis: American Optometric Association, 2002
- Pediatric Eye Disease Investigator Group. Randomized trial of treatment of amblyopia in children aged 7 to 17 years. *Arch Ophthalmol* 2005;123:437-447.
- Press LJ. Applied concepts in vision therapy. Santa Ana, CA: Optometric Extension Program, 2008.
- Rouse MW. Management of binocular anomalies: efficacy of vision therapy in the treatment of accommodative deficiencies. *Am J Optom Physiol Opt* 1987;64:415-20.
- Scheiman M, Mitchell GL, Cotter S, et al, for the Convergence Insufficiency Treatment Trial (CITT) Study Group. A Randomized Clinical Trial of Treatments for Convergence Insufficiency in Children. *Arch Ophthalmol*. 2005;123:14-24.
- Scheiman M, Wick B. Clinical management of binocular vision: heterophoric, accommodative, and eye movement disorders. 2nd Edition. Philadelphia: Lippincott, 2004.
- Suchoff IB, Petito GT. The efficacy of visual therapy: accommodative disorders and non-strabismic anomalies of binocular vision. *J Am Optom Assoc* 1986;57:119-25.
- Suchoff I, Gianutsos R. Rehabilitative optometric interventions for the adult with acquired brain injury. In: Grabios M, Garrison SJ, Hart KA, Lemkuhl LD, eds. *Physical Medicine and Rehabilitation*. Malden, Mass: Blackwell Science; 2000:608-621.
- Wick BW. Accommodative esotropia: efficacy of therapy. *J Am Optom Assoc* 1987;58:562-6.
- Wick B, Wingard M, Cotter S, Scheiman M. Anisometric amblyopia: is the patient ever too old to treat? *Optom Vis Sci* 1992;69:866-78.

## R) "The Efficacy of Optometric Vision Therapy"

Report by the American Optometric Association

The purpose of this paper is to offer supporting documentation for the efficacy and validity of vision therapy for modifying and improving vision functioning.

Optometry is an independent primary health care profession. Its scope of practice includes the prevention and remediation of disorders of the vision system through the examination, diagnosis, treatment, and/or management of visual efficiency and eye health as well as the recognition and diagnosis of related systemic manifestations, all of which are designed to preserve and enhance the quality of our lives and environment.

Optometrists examine the eyes and related structures to determine the presence of vision problems, eye disease, and other abnormalities. They gather information on the vision system during the optometric examination, diagnose any conditions discovered, and prescribe individual or combinations of interventions such as corrective lenses, prescription drugs, contact lenses, and vision therapy.

The American Optometric Association considers vision therapy an essential and integral part of the practice of optometry (1). Forty-three states specifically describe vision training, orthoptics, or some synonym in their definitions of the profession of optometry. The Institute of Medicine of the National Academy of Sciences (2), the Dictionary of Occupational Titles of the Employment and Training Administration (3), the U.S. Public Health Service (4), the U.S. Dept. of Labor, Employment and Training Administration (5), the National Center for Health Statistics (6), the Bureau of Labor Statistics (7), The Dept. of Health and Human Services (8) and the Association of Academic Health Centers (9) all include vision therapy in their definitions of the profession of optometry.

The theory and procedures underlying the diagnosis and management of vision disorders are taught in all the schools and colleges of optometry (9). In addition, the National Board of Examiners in Optometry (10) and the majority of the various state licensing agencies examine applicants for their theoretical and clinical knowledge in vision therapy.

### **What is vision therapy / visual training?**

Vision therapy (also called vision training, eye training, and eye exercises) is a clinical approach for correcting and ameliorating the effects of eye movement disorders, nonstrabismic binocular dysfunctions, focusing disorders, strabismus, amblyopia, nystagmus, and certain visual perceptual (information processing) disorders. The practice of vision therapy entails a variety of non-surgical therapeutic procedures designed to modify different aspects of visual function (11). Its purpose is to cure or ameliorate a diagnosed neuromuscular, neurophysiological, or neurosensory visual dysfunction.

Vision therapy typically involves a series of treatments during which carefully planned activities are carried out by the patient under professional supervision in order to relieve the visual problem. The specific procedures and instrumentation utilized are determined by the nature and severity of the diagnosed condition. Vision therapy is not instituted to simply strengthen eye muscles, but rather is generally done to treat functional deficiencies in order for the patient to achieve optimal efficiency and comfort.

The treatment may appear to be relatively uncomplicated, such as patching an eye as part of amblyopia therapy. Or, it may require complex infrared sensing devices and computers, which monitor eye position and provide feedback to the patient to reduce the uncontrolled jumping of an eye with nystagmus.

Treatment of strabismus, or turned eye, can involve complex optical and electronic instruments or such simple devices as a penlight or a mirror. The particular procedures and instruments are dependent on the nature of the visual dysfunction and the doctor's clinical judgment.

### **Who can benefit?**

Vision therapy is utilized for conditions which include oculomotor dysfunctions, non-strabismus binocular coordination problems, accommodative disorders, strabismus, amblyopia, and nystagmus.

These disorders and dysfunctions have a prevalence rate second only to refractive conditions, such as myopia and hyperopia, and are far greater than most ocular diseases (12-16). Graham (17) reports overt strabismus in almost 4 percent of over 4,000 school children. Among clinical cases, Fletcher and Silverman (18) found 8 percent of 1,100 to be strabismic. Other studies have generally found rates between these two levels (19).

The reported prevalence of amblyopia varies somewhat depending upon the specific criteria used, with low estimates at approximately 2 percent (20), and ranging up to 8.3 percent in the Rand HIE report (21), and also in the study by Ross, Murray and Steed (22). The National Society to Prevent Blindness estimates 127,000 new cases of amblyopia per year in the United States (23).

Non-strabismic binocular coordination anomalies have an even higher incidence. Convergence insufficiency is reported in 15 percent of adults by Duke-Elder (24). Graham (15) reports high heterophorias in over 13 percent, while Hokoda (25) found fusion or accommodative problems in 21 percent of a non-presbyopic clinical population. The recently developed New York State Vision Screening Battery probes oculomotor, binocular, accommodative, and visual perceptual function. Testing of 1,634 children with this battery revealed a failure rate of 53 percent (27).

When "special" populations are considered, the incidence of ocular coordination and visual processing problems becomes very high. Among children who are reading disabled, as many as 80 percent show deficiency in one or more basic visual skills (26). Grisham (28) has recently reported that children with reading problems showed greater than a 50 percent prevalence of visual deficiencies in accommodation, fusional vergence or gross convergence, compared to their normally achieving peers. Cerebral palsied patients show an incidence of strabismus as high as 50 percent, (29,30).

The hearing impaired (31,32), emotionally impaired (33), and developmentally disabled (34,35) also demonstrate unusually high prevalence rates of visual problems. This is of particular importance because almost 11 percent of the school population has been identified as having one of the above handicapping conditions (36).

Our culture continues to foster higher educational standards and produces work related tasks, which are increasingly visually demanding. This is evident in the difficulties encountered by video display terminal (VDT) operators. A majority of surveys have shown that more than 50 percent of VDT workers report they experience some type of ocular discomfort or blurring (37,38). The National Academy of Sciences (39) concluded that the oculomotor and binocular vision changes noted at video display terminals are similar to those that occur during standard nearpoint tasks.

### **What are oculomotor skills and oculomotor dysfunctions? [Tracking and eye movements]**

Clear vision occurs when a precisely focused image of the object of regard is centered on the fovea and when accurate eye movements maintain this relationship. The components of the oculomotor or eye

movement system include fixations, vestibular and optokinetic movements, saccades, and pursuit movements (40).

Each one of the components has its own distinct and different neuroanatomical substrate and functional neurophysiology (41). There are times when several components interact. An example of this occurs when the pursuit system interacts with other systems to create the ocular stabilization or position maintenance system (42) to hold the eyes steady.

Nystagmus, a to-and-fro involuntary movement of the eyes, is caused by disturbances in the mechanisms that hold images steady (position maintenance) and may be exhibited in over a dozen different clinical patterns of movement (43). This loss of ability to maintain central fixation and eye position with the foveal area is one of the characteristics of pathological nystagmus.

Patients with amblyopia represent another class of individuals with impaired central fixational ability. Lack of ability to steadily fixate with the fovea is accompanied by reduced visual acuity and is commonly observed in anisometropic and especially strabismic amblyopes. Their characteristics have been described extensively (44-46). Abnormal saccadic and pursuit eye movements are exhibited in strabismic amblyopes and appear to be related to dysfunctions in the monocular motor control center for position maintenance (47-49).

When nystagmus or nystagmoid movements are present, the clinical identification of fixation pauses, regressions and progressions during reading become difficult. The erratic eye movements interfere with efficient visual information processing (50,51).

During reading, the function or behavior of the eye movement system involves more than the physical movement of the eyes alone. This functional component involves the integration of the eye movements with higher cognitive processes including attention, memory, and the utilization of the perceived visual information (52).

Clinical and research evidence strongly suggest that many children and adults who have difficulty with both reading and non-reading visual information processing tasks exhibit abnormal eye movements (53-66).

Numerous studies (67-69) indicate that there is a distinct difference in the oculomotor (eye movement) patterns between children with reflective strategies or styles of processing visual information and those with impulsive styles. There is evidence that children and adults with attentional difficulties and hyperactivity exhibit inefficient eye movement patterns that interfere with visual information processing (70-74).

In summary, there are a variety of dysfunctions in the oculomotor system. Their clinical manifestations are quite often related to problems with functional visual performance and the efficient processing of information.

#### **Can eye movement skills be modified?**

Improvement in eye movement control and efficiency has been reported in individual case studies following vision therapy (75-77).

Wold et al (78) reported on 100 consecutive optometric vision therapy patients whose eye movement skills were rated on the Heinsen-Schrock Performance Scale (79). This is a 10-point observational scale

for scoring saccadic and pursuit eye movement performance. Only 6 percent of the children passed the eye movement portion prior to therapy. Post-therapy reevaluation revealed that 96 percent of the children were able to pass.

Heath (80) discussed the influence of ocular-motor proficiency on reading. Sixty third and fourth graders who scored below the 40th percentile on the Metropolitan Reading Test and failed the ocular pursuit subtest of the Purdue Perceptual Motor Survey were divided into control and experimental groups. Results of the study showed significant improvement in ocular pursuit ability for the experimental compared to the control group. In addition, those children receiving therapy were found to score significantly better on a post-test of the Metropolitan Reading Test.

Fujimoto et al (81) compared the use of various techniques for saccadic fixation training. In this controlled clinical trial, both of the treated groups showed a statistically significant improvement in speed and accuracy of eye movements compared to an untreated control group.

A controlled study of pursuit eye movements was conducted by Busby (82) in an enhancement program for special education students. The subjects were rated on their ability to maintain fixation on a moving target. The rating procedure was shown to have a high interrater reliability. The results showed statistically significant improvement by the experimental group in pursuit eye movement and persistence of the therapeutic effect on retesting at a 3-month interval after conclusion of the therapy.

Punnett and Steinhauer (83) conducted a controlled study investigating the effects of eye movement training with and without feedback and reinforcement. There were clear post-training differences between the eye movement skills of the control and experimental group of reading disabled students. This demonstrated that the use of reinforcement in training oculomotor facility could improve those skills. There was an improvement in reading performance following the oculomotor training as well. Similar results demonstrating the trainability of eye movements have been obtained in studies employing behavior modification and reinforcement (84,85).

Modifying and improving the oculomotor ability to maintain central fixation and eye position in nystagmus patients has been reported over the years in various studies.

The use of after-images (86,87) and Emergent Textual Contour training to provide visual biofeedback regarding eye position and stability has had some success in improving fixational ability. Orthoptics, as well as verbal feedback techniques, have helped some patients in reducing their nystagmus (88-90).

More recently, the application of eye movement auditory biofeedback in the control of nystagmus has shown positive results. Ciufredda et al (91) demonstrated a significant reduction in the amplitude and velocity of eye movements in congenital nystagmus patients. Vision was improved, and positive cosmetic and psychological changes were reported as well. Abadi et al (92) reported reduction in nystagmus and improvement of contrast sensitivity after auditory biofeedback training. In addition to nystagmus, the use of auditory biofeedback has been successfully used in expanding the range of eye movement in gaze limitations (93).

There is evidence (94) that large and unsteady eye movements occur in the eyes of amblyopic patients during attempted monocular fixation. A number of studies report the successful treatment of amblyopia resulting in improved vision and oculomotor control (95-98). Occlusion therapy, a passive procedure, has been a standard and relatively successful approach for many years (99-111). However, there are



individuals that either do not or cannot respond to occlusion therapy. There is evidence that occlusion with active vision therapy is more effective than occlusion alone (112). Pleoptics (113,114) is an active vision therapy procedure in which patients receive visual feedback about their position of fixation and direction of gaze. These procedures are designed to correct the positional fixation problem and thereby improve the vision of the patient. Pleoptics has been used successfully in treating eccentric fixation in individuals not responding to regular occlusion therapy (115-118).

Vision therapy for amblyopia incorporates a broad spectrum of procedures, including occlusion techniques, pleoptic techniques and visual-motor spatial localization feedback techniques using after-images and entoptic phenomena (45,79) with a high success rate (119-124).

The question of age and its influence on the efficacy of amblyopia therapy has been addressed in a number of studies and reviews. These indicate that a significant improvement in oculomotor and vision function can be achieved even in adulthood (125). It is clear from the evidence that amblyopia and its oculomotor components can be successfully treated with occlusion and active vision therapy for a wide range of patients of all ages.

Studies have demonstrated that it is possible to change and improve inefficient and inadequate visual information processing strategies and visual attention patterns. Many of these changes have been accompanied by enhanced eye movements (126-138).

A number of techniques used to improve these poor visual scanning and attention problems in children and adults, e.g., tachistoscopic procedures, pursuit and fixation activities and eye-hand coordination techniques have been described and utilized professionally for many years (79,139-143).

### **What are accommodative dysfunctions and their remediation? [Focusing]**

Accommodative (focusing) dysfunctions have been described in detail (144-146) in numerous sources and are clinically classified as accommodative spasm, accommodative infacility, accommodative insufficiency and ill-sustained accommodation. There are also clearly defined syndromes associated with accommodative dysfunctions (147-155).

The literature discusses many symptoms common to accommodative dysfunctions as a group. These have been described as reduced nearpoint acuity, a general inability to sustain nearpoint activity, asthenopia, excessive rubbing of the eyes, headaches, periodic blurring of distance vision after prolonged near activities, periodic double vision at near and excessive fatigue at the end of the day (152,154,156-160).

The efficacy of applying vision therapy procedures in improving accommodative functioning has considerable basic science and clinical research support. Studies have shown that accommodative findings, although under autonomic nervous system control, can respond to voluntary command (161-163) and can be conditioned (164). These studies demonstrate that voluntary control of accommodation can be controlled, trained, and transferred.

Once pathological or iatrogenic causes have been eliminated, the treatment of accommodative deficiencies includes plus lenses for near work and vision therapy aimed at improving the functioning of the accommodative mechanism (165-168). Levine et al (156) established baseline statistics for diagnostic accommodation findings which differentiate symptomatic from asymptomatic patients. Their

findings were in close agreement with a similar study by Zellers and Rouse (152). The significant element of these studies is the relationship between symptoms and inadequate accommodative facility.

Wold (78) reported on 100 children who had undergone accommodative vision therapy procedures. These clinically selected cases showed an 80 percent rate of improvement in accommodative amplitude and 76 percent in accommodative facility using a pre- and post-treatment ordinal criterion referenced scaling method. These results are similar to those reported by Hoffman and Cohen (168) in which 70 patients were successfully treated for accommodative insufficiency and infacility based on clinical findings.

Liu et al (169) investigated accommodative facility disorders by objective laboratory methods using a dynamic optometer with an infrared photomultiplier. They objectively identified the dynamic aspects of the accommodative response that were improved by vision therapy. Young adults with symptoms related to focusing difficulties were treated by procedures commonly used in orthoptic or vision therapy practice. Significant improvement in their focus flexibility occurred and these changes correlated with marked reduction or elimination of symptoms. Standard clinical measures of accommodative facility were found to correlate well with the more objective measures.

Bobier and Sivak (170) replicated the work of Liu et al (169) using a greater degree of recording precision with a dynamic photorefractor (television camera and monitor with light-emitting diodes). They found no evidence of regression in improved focusing flexibility during an 18-week interval after cessation of training. The subjects' symptoms also abated as accommodative function normalized. Hung et al (171) demonstrated the efficacy of accommodation, vergence and accommodative vergence orthoptic therapy using a dynamic binocular simulator. This experiment objectively validated optometric vision therapy procedures through use of photoelectric eye movement recording systems and an optometer.

There is a higher prevalence of accommodative insufficiencies and infacilities in persons with cerebral palsy (172). Duckman demonstrated that accommodative abilities can be modified and improved in a cerebral palsy population using vision therapy techniques (173,174).

Since accommodative changes take place when looking from near to far and back to near, Haynes and McWilliams (175) investigated the effects of training this near-far response on school age and college students. Their results indicate that this near-far response ability is trainable and can be improved with vision therapy.

Weisz (176) has shown that improvement in accommodative ability transfers to improvement in near point task performance. In a double blind clinical study following vision therapy, her experimental group was found to improve significantly in accuracy of performance on a Landolt-C resolution task as compared with the controls.

Hoffman (160) investigated the impact of accommodative deficiencies on visual information processing tasks. He compared the results of vision therapy for the accommodative problems in an experimental and control group of school age children. This study indicated that by improving accommodative skills, there was a concomitant improvement in his subject's visual perceptual skills.

Recently, in a detailed series of analyses involving retrospective studies, Daum (177-180) investigated the full range of accommodative disorders. He used a stepwise discriminant analysis of regression

variables in patient care records, to establish a model to determine the length of treatment necessary and to predict the success of treatment for accommodative disorders.

In conclusion, these studies demonstrate that accommodative disorders can cause significant discomfort, inefficiency or avoidance of nearpoint tasks. They further demonstrate that when diagnosed and treated appropriately, these dysfunctions may be ameliorated or eliminated through vision therapy.

### **What are binocular vision disorders and their remediation? [Eye coordination and alignment]**

Normal and efficient binocular vision is based on the presence of motor alignment and coordination of the two eyes and sensory fusion. The range of binocular disorders extends from constant strabismus with no binocular vision present to nonstrabismic binocular dysfunctions, e.g., convergence insufficiency (146).

The first category is nonstrabismic binocular disorders. Standard techniques and diagnostic criteria in the assessment of the vergence system and binocular sensory fusion ability have been described in detail elsewhere (181-185).

Patients exhibiting nonstrabismic anomalies of binocular vision quite often report feeling ocular discomfort and asthenopia (186). Some of the patient complaints include eyestrain, soreness of the eyes, frontal and occipital headaches, and ocular fatigue, which result in an aversion to reading and studying (187,187a).

Vision therapy has long been advocated as a primary intervention technique for the amelioration of nonstrabismic anomalies of binocular vision (188-194). Suchoff and Petito (146) have concluded that vision therapy for these conditions is directed toward several therapeutic goals: First, to increase the efficiency of the accommodative system so as to facilitate a more effective interaction between this system and the vergence system. Second, to maximize the functioning of the fusional vergence system (i.e., divergence and convergence) and the binocular sensory system. Because the training of accommodation has been covered in the previous section, the remainder of this section will be devoted to the evidence of the modifiability of the vergence system.

Clinical vision therapy procedures are intended to improve the patient's ability to compensate for fusional stress, which may result in asthenopia, headache and/or diplopia. A number of studies will be reviewed showing that improvements can be made in fusional vergence skills by vision therapy procedures.

The clinical assumption that fusional vergences can be trained is not a new one. Over 50 years ago, Berens et al advocated the use of this aspect of orthoptics for all nonstrabismic anomalies of binocular vision (195). Within the past several years a number of investigators have sought to determine experimentally whether the clinical assumption of the trainability of the vergence system was a valid one.

Daum (196) prospectively studied a group of 35 young adults. The results of daily vision therapy showed statistically significant improvement in convergence ranges. The gains persisted on post-testing 24 weeks after completion of the therapy program. The conclusion was that relatively short periods of training can provide long-lasting increases in vergence ability.

Daum (197) conducted a retrospective study of 110 patients who received treatment for convergence insufficiency. The patients were classified according to the effectiveness of the treatment program into total success, partial success or no success categories. Post-training diagnostic findings and changes in patient symptomatology were used to define the classification categories. A comparison of pre- and post-training findings revealed statistically significant improvement. In a companion report, (198) a portion of the above data (197) was used to investigate and identify which of 14 common diagnostic measures best predicted the success of the vision-training program. These measures were 75 percent accurate in predicting efficacy of the vision-therapy program.

Another study (199) utilized tonic and phasic vergence training and demonstrated impressive changes in convergence and divergence abilities. The 34 subjects were randomly assigned in a double crossover design, wherein subjects served as their own controls, and learning effects were controlled.

In another study, Veagan used a motor-driven prism stereoscope (ophthalmic ergograph) to train divergence and convergence (200). Forty-seven adults were divided into convergence and divergence experimental and control groups. The findings led Veagan to conclude that sustained divergence and convergence training showed large and significant immediate and stable improvement in the trained vergence ranges of the experimental groups.

Vaegan and McMonnies (201) utilized a recording device that measured eye movements during vergence activity. They were able to objectively demonstrate that convergence training with prism-induced changes resulted in sustained improvement of convergence ability. In a companion study, Vaegan (202) demonstrated substantial long-lasting gains in convergence and divergence ability from both tonic and phasic vergence training.

Pantano (203) studied over 200 subjects with convergence insufficiency who underwent vision therapy and evaluated them 2 years later. The majority remained asymptomatic with normal clinical findings. Those subjects who had learned to control convergence and accommodation together had the best success.

Grisham (204, 205) used vergence latencies, velocity, and step vergence tracking rate by measuring them objectively with infrared eye monitor recordings; he reported improved step vergence tracking after vision therapy of 4 to 8 weeks.

Cooper and Duckman, in their extensive review of convergence insufficiency, stated that 95 percent of the patients reported in these studies responded favorably to vision therapy for this binocular disorder (206).

Cooper and Feldman (207) investigated the role and clinical use of operant conditioning in vision therapy based on random dot stereograms (RDS). They demonstrated that response-contingent positive reinforcement, immediate feedback, and preprogrammed systematic changes during discrimination learning improves convergence ability. Control and experimental groups were formed with subjects matched in baseline convergence ability and randomly assigned to each group. The convergence ranges of the experimental group improved significantly while there were little or no increases for the control group.

Cooper et al (208) conducted a controlled study of vision therapy and its relationship to symptomatology for a group of patients with convergence insufficiency. A vision-therapy program of

fusional vergence activities was administered in a matched-subjects control group crossover design to reduce placebo effects. They used a written assessment scale for rating asthenopia in terms of discomfort and/or fatigue, and conclusively demonstrated that the symptoms were eliminated or relieved. Clinical findings also improved, corroborating the subjective assessments.

Dalziel (209) reported on 100 convergence insufficiency patients who did not meet Sheard's criterion, and were given a program of vision therapy. After vision therapy, clinical findings were again assessed and 84 percent of the patients successfully met Sheard's criterion. Eighty-three percent of the patients reported they had symptoms of discomfort or loss of efficiency prior to treatment. Only 7 percent reported these symptoms after therapy. The post-training group who failed to meet Sheard's criterion correlated well with those still reporting subjective symptoms.

Wold (78) reported on the results of 100 patients who underwent vision therapy. Based on standard clinical tests, only 25 percent of the children had adequate binocular sensory fusion prior to vision therapy and 9 percent had adequate binocular fusional vergence. Post-training evaluation showed 96 percent had achieved appropriate sensory fusion findings and 75 percent demonstrated adequate fusional vergence ranges.

Wittenberg et al (210), along with Saladin and Rick (211), used slightly different techniques and demonstrated that stereopsis thresholds could be improved in normal subjects. In Dalziel's (212) study there was a statistically significant improvement in stereopsis after vision therapy.

### **Strabismus**

Another category of binocular vision disorders is strabismus. Strabismus may be described as a misalignment of the eyes (referred to as crossed eyes, eye turn, weak eye muscle, etc.). Many forms and variations of strabismus exist, depending upon direction and amount of the eye turn, the number of affected nerves or muscles, and the degree to which it is associated with reduced vision. The clinical characteristics and diagnostic criteria have been described in detail (212-215).

Numerous comprehensive reviews and studies relating to the success of vision therapy for strabismus exist. Flom (216) reviewed studies and used detailed multifactorial analysis. This revealed an overall functional cure rate for strabismics receiving vision therapy of 50 percent, with esotropia less responsive than exotropia. Ludlam (217) evaluated a sample of 149 unselected strabismics who received vision therapy and determined a 73 percent overall success rate utilizing the rigorous criteria established by Flom.

In a longitudinal follow-up study of this population, Ludlam and Kleinman (218) found 89 percent of these patients had retained their functional cure (binocular vision present). The long-term overall success rate of vision therapy was calculated at 65 percent. If one adopts a less stringent definition of "success," such as the cosmetic criterion of "straight-looking eyes" employed in some less precise studies, the success rate increases to 96 percent of the re-analyzed population, or a 71 percent long-term success rate.

Flax and Duckman, (219) in their literature review of treatment for strabismus, found strong support for the efficacy of vision therapy for strabismus. They gathered data from numerous studies, each of which met rigorous criteria for success, and reported an overall success rate of 86 percent.

In a controlled study of 100 cases (220) Gillan reported that 76 percent of strabismic patients attained a cosmetic cure with orthoptics. None of those in the control group, treated with glasses alone, showed a spontaneous cure.

In a series of controlled studies conducted by Guibor (221-223), 50 percent of the experimental group achieved alignment of the eyes with glasses and vision therapy (orthoptics) as compared with only 12.5 percent of the control group who received glasses without vision therapy.

More recently, Ziegler et al (224) conducted a literature review of the efficacy of vision therapy for strabismus. An important contribution is their comparative analysis of published papers using the functional cure criteria defined by Flom. They noted the study conducted by Etting (225), in which he reported a 65 percent overall success rate in patients with constant strabismus (57 percent of esotropes and 82 percent of exotropes), 89 percent success rate with intermittent strabismus (100 percent of esotropes and 85 percent of exotropes), and a 91 percent success rate when retinal correspondence was normal.

In a study designed to investigate the effectiveness of vision therapy utilizing computer-generated stereo graphics for subjects with strabismus, Kertesz and Kertesz (226) reported a 74 percent success rate in 57 strabimics. They combined traditional vision therapy techniques with computer-generated stimuli as successfully applied by Cooper<sup>07</sup> to the remediation of nonstrabismic binocular vision anomalies. The functional cures obtained persisted on long-term follow-up visits for a period of up to five years.

Sanfilippo and Clahane (227) designed a prospective study of the results of orthoptic therapy for divergent strabismus (exotropia). Of the patients who completed the study, 64.5 percent attained a functional cure upon completion, and 51.7 percent retained this status on an average follow-up interval of five years and four months.

In two studies on the effectiveness of orthoptics (vision therapy) for intermittent and constant exotropes, Altizer (228) and Chryssanthou (229) found the majority of their patients had significant improvement in clinical findings as well as relief of symptoms.

Goldrich (230) reviewed records of patients completing a vision-therapy program for exotropia of the divergence excess type. Of the patients reviewed, 71.4 percent attained a functional cure following approximately five months of standardized sequential therapy procedures used in-office as well as at home.

Several studies have applied biofeedback in vision therapy to assist in training patients to align their eyes (231-236). The use of biofeedback to enhance traditional vision therapy, provide reinforcement, and increase motivation was supported in these studies.

Strabismic patients exhibiting esotropia with anomalous correspondence tend to be the most difficult to successfully treat. The use of more aggressive and sophisticated techniques for vision therapy has been reported with a better success rate for anomalous correspondence and esotropia than earlier studies (237,238). In general, the treatment period tends to be longer for anomalous correspondence and esotropia than other types of strabismus.

## **Summary and conclusion**

Vision is not simply the ability to read a certain size letter at a distance of 20 feet. Vision is a complex and adaptable information-gathering and processing system, which collects, groups, analyzes, accumulates, equates and remembers information.

In this review, some of the essential components of the visual system and their disorders, which can be physiologically and clinically identified, i.e., the oculomotor, the accommodative, and the fusional vergence systems, have been discussed. Any dysfunctions in these systems can lessen the quality and quantity of the initial input of information into the visual system.

Deficiencies in one or more of these visual subsystems have been shown to result in symptoms, such as blurred or uncomfortable vision or headaches, or behavioral signs such as rubbing of the eyes, eyes turning inward or outward, reduced job efficiency or reading performance, or simply the avoidance of near point tasks. In addition, these signs/symptoms may contribute to reducing a person's attention and interest in near tasks. The goal of vision therapy is to eliminate visual problems, thereby reducing the frequency and severity of the patient's signs and symptoms. Vision therapy should only be expected to be of clinical benefit to patients who have detectable visual deficiencies.

In response to the question, "How effective is vision therapy in remediating visual deficiencies?" it is evident from the research presented that there is sufficient scientific support for the efficacy of vision therapy in modifying and improving oculomotor, accommodative, and binocular system disorders, as measured by standardized clinical and laboratory testing methods, in the majority of patients of all ages for whom it is properly undertaken and employed.

The American Optometric Association reaffirms its long-standing position that vision therapy is an effective therapeutic modality in the treatment of many physiological and information-processing dysfunctions of the vision system. It continues to support quality optometric care, education and research and will cooperate with all professions dedicated to providing the highest quality of life in which vision plays such an important role (1).

## **Acknowledgment**

The Task Force would like to acknowledge Jack E. Richman, O.D., Nathan Flax, O.D., and Leonard Press, O.D., for their major contributions to the research and preparation of this document. A number of editorial revisions were based on the recommendations of the following individuals and organizations: Arol Augsburg, O.D., Louis G. Hoffman, O.D., Mike Rouse, O.D., Ralph T. Garzia, O.D., the College of Optometrists in Vision Development, and the Optometric Extension Program Foundation. The members of the 1985-86 Task Force also contributed to the initial development of this document: Donald J. Getz, O.D., chairman; Paul A. Harris, O.D.; Paul J. Lederer, O.D.; Ronald L. Bateman, O.D.; and D. Gary Thomas, O.D.

Members of the task force:

Allen H. Cohen, O.D., chairman; Sue E. Lowe, O.D.; Glen T. Steele, O.D.; Irwin B. Suchoff, O.D.; Daniel D. Gottlieb, O.D., consultant; Torrance L. Trevorrow, O.D., staff.

## References

1. Special report: Position statement on vision therapy. J Am Optom Assoc 1985;56:782-83.
2. Costs of education in the health professions--1974. Institute of Medicine of the National Academy of Sciences.
3. Dictionary of occupational titles, 1977. 4th ed. GPO No. 029-013-0079-9, Employment and Training Administration.
4. Facts about medical and dental practitioners 1975-76. US Department of Health, Education and Welfare Public Health Service Health Resources Administration, Bureau of Health Resources Development.
5. Health careers guidebook 1979. 4th ed. GPO No. 029-000- 00343-2, Department of Labor, Employment and Training Administration and US Department of Health and Human Services, Health Resources Administration.
6. National Center for Health Statistics 1976-77. US Department of Health, Education, and Welfare, Health Manpower and Health Facilities, Health Resources Statistics.
7. Occupational outlook handbook, April 1982. US Department of Labor Bureau of Labor Statistics, Bulletin 2200.
8. Third report to the president and congress on the status of health professions personnel in the United States. Publication No. (HRS) 82-2. January 1982, Department of Health and Human Services.
9. National Board of Examiners in Optometry. New content outline. Implementation plans for the new entry-level examinations. Washington, DC: National Board of Examiners in Optometry, 1986.
10. Special Committee Report, Association of Schools and Colleges of Optometry. Curriculum model for oculomotor, binocular and visual perception dysfunctions. Washington, DC, 1987.
11. Flax N, ed. Vision therapy and insurance: A position statement. New York: State University of New York, State College of Optometry, 1986.
12. National Center for Health Statistics. Eye examination findings among children, United States. DHEW Publication No. 72-1057, Series 11, No 115. Rockville, Md: Department of Health, Education, and Welfare, 1972.
13. National Center for Health Statistics. Refraction status and motility defects of persons 4-74 years, United States DHEW Publication No.78-1654, Series 11, No 206. Hyattsville, Md: Department of Health, Education and Welfare, 1978.
14. National Center for Health Statistics. Refraction status of youths 12-17 years, United States. DREW Publications No. 75-1630, Series 11, No.148, Rockville, Md: Department of Health, Education and Welfare, 1974.
15. Bennett GR, Blondin M, Ruskiewicz J. Incidence and prevalence of selected visual conditions. J Optom Assoc 1982; 53:647-56.



16. Blum HL, Peters HB, Bettman JW. Vision screening for elementary schools: the Orinda study. Berkeley: University of California Press, 1959.
17. Graham PA. Epidemiology of strabismus. *Br J Ophthalmol* 1974;58:224-31.
18. Fletcher CF, Silverman SJ. Strabismus. Part I. A summary of 1110 consecutive cases. *Am J Ophthalmol* 1966;61:86-94.
19. Frensdén AD. The occurrence of squint. *Acta Ophthalmol (Suppl)* 1960; 62.
20. Flom MC, Neumaier RW. Prevalence of amblyopia. *Am J Optom Arch Am Acad Optom* 1966;73:732-51.
21. Rubenstein RS, Lohr KN, Brook RH, et al. Measurement of the physiological health of children. Vol 4, Vision Impairments. Santa Monica: Rand Corp, 1985.
22. Ross E, Murray AL, Stead S. Prevalence of amblyopia in grade 1 school children in Saskatoon. *Can J Public Health* 1977; 68:491-3.
23. Operational Research Department of the National Society to Prevent Blindness. Vision problems in the United States. A statistical analysis. New York: National Society to Prevent Blindness, 1980.
24. Duke-Elder S. The physiology of the eye and of vision. In: Duke-Elder S, ed. *System of ophthalmology*, vol IV: St. Louis: Mosby, 1968.
25. Hokoda SC. General binocular dysfunctions in an urban optometry clinic. *J Am Optom Assoc* 1985;56:560-3.
26. Hoffman LH. Incidence of vision difficulties in children with learning disabilities. *J Am Optom Assoc* 1980;51:447-51.
27. Lieberman S, Cohen A, Stolzberg M, et al. Validation study of the New York State Optometric Association (NY-SOA) vision
28. Grisham JD. Computerized visual therapy-year 1 report. Palo Alto: American Institutes for Research, 1986.
29. LoCascio GP. A study of vision in cerebral palsy. *Am J Optom Physiol Opt* 1977;54:332-7.
30. Scheiman MN. Optometric findings in children with cerebral palsy. *Am J Optom Physiol Opt* 1984;61:321-1.
31. Gottlieb DD, Allen W. Incidence of visual disorders in a selected population of hearing impaired students. *J Am Optom Assoc* 1985;56:292-6.
32. Mohindra I. Vision profile of deaf children. *Am J Optom Physiol Opt* 1976; 53:412-9.
33. Lieberman S. The prevalence of visual disorders in a school for emotionally disturbed children. *J Am Optom Assoc* 1985;56:800-5.
34. Levy B. Incidence of oculo-visual anomalies in an adult population of mentally retarded persons. *Am J Optom Physiol Opt* 1984;61:324-6.
35. Woodruff ME, Cleary E, Bader D. The prevalence of refractive and ocular anomalies among 1242 institutionalized mentally retarded persons. *Am J Optom Physiol Opt* 1980;57:70-6.

36. Plisko VW, Stern JD, eds. The condition of education, 1985. Washington: United States Department of Education, 1985.
37. Smith MJ, Cohen BGF, Stammerjohn LW; Jr, et al. An investigation of health complaints and job stress in video display operation. *Hum Factors* 1981;23:387-400.
38. National Institute of Occupational Safety and Health. Potential health hazards of video display terminals. DHHS (NIOSH) Publication No. 81-129. Cincinnati: National Institute for Occupational Safety and Health, 1981.
39. Panel on Impact of Video Viewing on Vision of Workers. Video displays, work, and vision. Washington: National Academy Press, 1983.
40. Leigh JR, Zee DS. The diagnostic value of abnormal eye movements. A pathophysiological approach. *Johns Hopkins Med J* 1982;151:122-35.
41. Leigh JR, Zee DS. The neurology of eye movements. Philadelphia: FA Davis, 1984:11-89.
42. Leigh JR, Zee SD. The neurology of eye movements. Philadelphia: FA Davis, 1984:6.
43. Leigh JR, Zee DS. The neurology of eye movements. Philadelphia: FA Davis, 1984:192-94.
44. Schor C. A directional impairment of eye movement control in strabismus amblyopia. *Invest Ophthalmol Vis Sci* 1975; 15:692-7.
45. Schapero M. Amblyopia. Philadelphia: Chilton, 1971.
46. Von Noorden GK. Burian-Von Noorden's binocular vision and ocular motility. 2nd ed. St. Louis: Mosby, 1980: 219-49.
47. Von Noorden GK. Mackensen G. Pursuit movements of normal and amblyopic eyes - an electromyographic study. II. Pursuit movements of amblyopic patients. *Am J Ophthalmol* 1962;53:477-87.
48. Ciufredda KJ, Kenyon RV; Stark L. Abnormal saccadic substitution during small amplitude pursuit tracking in amblyopic eyes. *Invest Ophthalmol Vis Sci* 1979;18:506-16.
49. Ciufredda KJ, Kenyon RV, Stark L. Saccadic intrusions in strabismus. *Arch Ophthalmol* 1979;97:1673-9.
50. Metz HS, Jampolsky A, O'Meara DM. Congenital ocular nystagmus and nystagmoid head movements. *Am J Ophthalmol* 1974;6:1131-3.
51. Ciufredda KJ, Bahill AT, Kenyon RV, et al. Eye movements during reading: case reports. *Am J Optom Physiol Opt* 1976; 53:389-95.
52. Senders JW, Fisher DF, Monty RA, eds. Eye movements and higher psychological functions. Hillsdale, NJ: Lawrence Erlbaum Assoc, 1978.
53. Lefton LA. Eye movements in reading disabled children. In: Senders JW; Fisher DF, Monty RA, eds. Eye movements and higher psychological functions. Hillsdale NJ: Lawrence Erlbaum Assoc, 1978:225-37.
54. Senders JW, Fisher DF, Monty RA, eds. Eye movements: cognition and visual perception. Hillsdale, NJ: Lawrence Erlbaum Assoc, 1981.

55. Leigh. JR, Zee DS. The neurology of eye movements. Philadelphia: FA Davis, 1984:44-6.
56. Fisk JD, Goodale MA, Burkart G, et al. Progressive supranuclear palsy: The relationship between ocular motor dysfunction and psychological test performance. *Neurology* 1982; 32:698-705.
57. Pavlidis GT. Eye movements in dyslexia: Their diagnostic significance. *J Learn Disabil* 1985;18:42-50.
58. Pirozzolo FJ. Eye movements and reading disability. In: Rayner K, ed. *Eye movements in reading: perceptual and language processes*. New York: Academic Press, 1983:499-509.
59. Rayner K Eye movements in reading and information processing. *Psychol Bull* 1978;85:618-60.
60. Poynter HL, Schor C, Haynes HM, et al. Oculomotor functions in reading disability. *Am J Optom Physiol Opt* 1982; 59:116-27.
61. Pollatsek A. What can eye movements tell us about dyslexia? In: Rayner K, ed. *Eye movements in reading: perceptual and language processes*. New York: Academic Press, 1983:511-21.
62. Senders JW, Monty RA, eds. *Eye movements and psychological processes*. Hillsdale, NJ: Lawrence Erlbaum Assoc, 1976.
63. Kundel HL, Nodine CF. Studies of eye movements and visual search in radiology. In: Senders JW, Fisher DF, Monty RA, eds. *Eye movements and higher psychological functions*. Hillsdale, NJ: Lawrence Erlbaum Assoc, 1978:317 -28.
64. Locher PJ, Worms PP. Visual scanning strategies of neurologically impaired, perceptually impaired, and normal children viewing the Bender-Gestalt drawings. *Psychol in the Schools* 1977;14:147-57.
65. Locher PJ, Worms PF. Visual scanning strategies of perceptually impaired and normal children viewing the motor-free visual perception test. *J Learn Disabil*1981;14:416-9.
66. Tinker MA. *Bases for effective reading*. Minneapolis, MN: University of Minneapolis Press, 1966:81-94.
67. Ault RL, Crawford DE, Jeffrey WE. Visual scanning strategies of reflective, impulsive, fast-accurate, and slow-inaccurate children on the Matching Familiar Figures Test. *Child Dev* 1972; 43:1412-7.
68. Sato K. An investigation of visual scanning strategies of reflective and impulsive children and adults. *Jap Educ Psych* 1976 24:224-34.
69. Drake DM. Perceptual correlates of impulsive and reflective behavior. *Dev Psycho*1 1970; 2:202-14.
70. Cohen B, Bala S, Morris AG. Do hyperactive children have manifestations of hyperactivity in their eye movements? ERIC Document ED 112601, 1975.
71. Bala SP, Cohen B, Morris AG, et al. Saccades of hyperactive and normal boys during ocular pursuits. *Dev Med Child Neurol* 1981;23:323-36.
72. Richman JE. Use of a sustained visual attention task to determine children at risk for learning problems. *J Am Optom Assoc* 1986;57:20-6.
73. Simon MJ. Use of a vigilance task to determine school readiness of preschool children. *Percept Mot Skills* 1982; 54:1020-2.

74. Berch DB, Kanter DR. Individual differences. In: Warm JS, ed. Sustained attention in human performance. New York: John Wiley and Sons, 1984:143-70.
75. Ludlam WM. Visual training, the alpha activation cycle and reading. *J Am Optom Assoc* 1979;50: 111-5.
76. Ludlam WM. Optometric visual training for reading disability--a case report. *Am J Optom Physiol Opt* 197; 50:58-66.
77. Camuccio D, Griffin JR. Visual skills therapy--a case report. *Optom Mon* 1982;73:94-6.
78. Wold RM, Pierce JR, Keddington J. Effectiveness of optometric vision therapy. *J Am Optom Assoc* 1978;49:1047-59.
79. Griffin JR. Binocular anomalies-procedures for vision therapy. Chicago: Professional Press, 1982:349-65.
80. Heath, EJ, et al. Eye exercises and reading efficiency. *Academic Therapy* 1976;11:435-45.
81. Fujimoto DH, Christensen EA, Griffin JR. An investigation in use of videocassette techniques for enhancement of saccadic eye movements. *J Am Optom Assoc* 1985;56:304-8.
82. Busby RA. Vision development in the classroom. *J Learn Disabil* 1985;18:266-72.
83. Punnett AF, Steinhauer GD. Relationship between reinforcement and eye movements during ocular motor training with learning disabled children. *J Learn Disabil* 1984; 17: 16-9.
84. Punnett AF. Relationship between reinforcement and eye movements during vision therapy with dyslexic children. PhD thesis. Ann Arbor: University of Microfilms, 1981:24.
85. Feldman J. Behavior modification in vision training: facilitating prerequisite behaviors and visual skills. *J Am Optom Assoc* 1981;52:329-40.
86. Stohler T. Afterimage treatment of nystagmus. *Am Orthopt J* 1973;23:65-7.
87. Goldrich SG. Emergent textual contours: A new technique for visual monitoring in nystagmus, oculomotor dysfunction, and accommodative disorders. *Am J Optom Physiol Opt* 1981 ; 58:451-9.
88. Healy E. Nystagmus treated by orthoptics. *Am Orthopt J* 1952;2:53-5.
89. Stegall FW: Orthoptic aspects of nystagmus. *Am Orthopt J* 1973;23:30-4.
90. Ciufredda KJ, Kenyon RV; Stark L. Suppression of fixational saccades in strabismic and anisometropic amblyopia. *Ophthalmic Res* 1979;11:31-9.
91. Ciufredda KJ, Goldrich SG, Neary C. Use of eye movement auditory feedback in the control of nystagmus. *Am J Optom Physiol Opt* 1982;59:396-409.
92. Abadi RV; Carden D, Simpson J. A new treatment for congenital nystagmus. *Br J Ophthalmol* 1980;64:2-4.
93. Letourneau JE. Biofeedback reinforcement in the training of limitation of gaze: A case report. *Am J Optom Physiol Opt* 1976;53:672-6.

94. Schor CM, Flom MC. Eye position control and visual acuity in strabismus amblyopia. In: Lennerstrand G, Bach-y-Rita P, Collins CC, et al, eds. Basic mechanisms of ocular motility and their clinical manifestations. New York: Pergamon Press, 1975.
95. Ciufredda KJ. Visual system plasticity in human amblyopia. In: Hilfer RS, Sheffield JB, eds. Development of order in the visual system. New York: Springer-Verlag, 1986:212-44.
96. Burian HM, Von Noorden GK. Binocular vision and ocular motility. 3rd ed. St. Louis: Mosby, 1985.
97. Schapero M. Amblyopia. New York: Chilton Book Co, 1971.
98. Duke-Elder S, ed. System of ophthalmology, vol VI. Ocular motility and strabismus. St. Louis: Mosby, 1973:424-56.
99. Gortz H. The corrective treatment of amblyopia with eccentric fixation. Am J Ophthalmol 1960;49:1315-21.
100. Gregersen E. Occlusion treatment of squint amblyopia in young adults. Acta Ophthalmol 1966;44:166-8.
101. Brown MH, Edleman PM. Conventional occlusion in the older amblyope. Am Orthopt J 1976;26:34-6.
102. Eibschitz N, Friedman Z, Neuman E. Comparative results of amblyopia treatment. Metab Ophthalmol 1978;2:111-2.
103. Garzia, RP. The efficacy of visual training in amblyopia: A literature review. Am J Optom Physiol Opt 1987;64:393-404.
104. Nawratzki I. Treatment of amblyopia. Ir J Med Sci 1972; 8:1475-9.
105. Massie H. Fixing eye occlusion: Survey of approximately 1000 case histories of patients who received occlusion of the fixing eye. Trans Ophthalmol Soc Aust 1965;24:39-46.
106. Kupfer C. Treatment of amblyopia ex anopsia in adults. Am J Ophthalmol 1957;43:918-22.
107. Gregersen E, Rindziunski E. Conventional occlusion in the treatment of squint amblyopia. Acta Ophthalmol 1965;43:462- 74.
108. Scott WE, Stratton VB, Fabre J. Fulltime occlusion therapy for amblyopia. Am Orthopt J 1980;30:125-30.
109. Haldi B, Mitchelson JE. Amblyopia therapy: Expected results from standard techniques. Am Orthopt J 1981;31:19-28.
110. Ingram RM, Rogers S, Walker C. Occlusion and amblyopia. Br Orthopt J 1977;34:11-22.
111. Goodier HM. Some results of conventional occlusion. Br Orthopt J 1974;31:55-8.
112. Francois J, James M. Comparative study of amblyopic treatment. Am Orthopt J 1955;5:61-4.
113. Bangerter A. Amblyopienhandling. Aufl 2. Basel: Karger, 1955.
114. Bangerter A. Die occlusion in der pleoptik and orthoptic. Klin Monatsbl Augenheilkd 1960;136:305-31.

115. Girard LJ, Fletcher MC, Tomlinson E, et al. Results of pleoptic treatment of suppression amblyopia. *Am Orthopt J* 1962;12:12-31.
116. Jablonski M, Tomlinson E. A new look at pleoptics. *Ophthalmology* 1979;86:2112-4.
117. Mayweg S, Massie HH. A preliminary report of the more recent methods of treatment of amblyopia, especially when associated with eccentric fixation in cases of strabismus. *Br. J Ophthalmol* 1958;42:257-69.
118. Deller M, Streiff EB. Apropos de l'amblyopie a fixation excentrique. *Ophthalmologica* 1965; 150:76-82.
119. Selenow A, Ciufredda KJ. Vision function recovery during orthoptic therapy in an adult esotropic amblyope. *J Am Optom Assoc* 1986;57:132-40.
120. Ciuffreda KJ, Kenyon RV; Stark L. Different rates of functional recovery of eye movements during orthoptics treatment in an adult amblyope. *Invest Ophthalmol Vis Sci* 1979; 18:213-9.
121. Hoffman L, Cohen AH, Feuer G, et al. Effectiveness of optometric therapy for strabismus in a private practice. *Am J Optom Arch Am Acad Optom* 1970;47:990-5.
122. Shippman S. Video games and amblyopia treatment. *Am Orthopt J* 1985;35:2-5.
123. Porter EE. Treatment of amblyopia. *Am Orthopt J* 1962; 12:157.61.
124. Cohen AH. Monocular fixation in a binocular field. *J Am Optom Assoc* 1981; 52:801-6.
125. Birnbaum MH, Koslowe K, Sanet R. Success in amblyopia therapy as a function of age: A literature survey. *Am J Optom Physiol Opt* 1977;54:269-75.
126. Blackman S, Goldstein KM. Cognitive styles and learning disabilities. *J Learn Disabil*1982;15:106-15.
127. Messer SB. Reflection-impulsivity: a review. *Psychol Bull* 1976;83:1026-52.
128. Abikoff H. Cognitive training interventions in children: Review of a new approach. *J Learn Disabil*1979;12:123-35.
129. Meichenbaum DH, Goodman J. Training impulsive children to talk to themselves: A means of developing self-control. *J Abnorm Psychol* 1971;77:115-26.
130. Egeland B. Training impulsive children in the use of more efficient scanning techniques. *Child Dev* 1974;45:165-71.
131. Zelniker, Oppenheimer L. Modification of information processing of impulsive children. *Child Dev* 1973;44:445-50.
132. Orbach I. Impulsive cognitive style: Three modification techniques, *Psychol in the Schools* 1977;14:353-9.
133. McKinney JD, Haskins R. Cognitive training and the development of problem-solving strategies. *Except Educ Q* 1980;1.41-51.
134. Douglas VI, Parry P, Marton P, et al. Assessment of a cognitive training program for hyperactive children. *J Abnorm Child Psychol* 1976; 4:389-410.

135. Brown RT, Wynne ME. Correlates of teacher ratings, sustained attention, and impulsivity in hyperactive and normal boys. *J Clin Child Psycho* 1982;11:262-7.
136. Brown RT, Conrad KJ. Impulse control or selective attention. Remedial programs for hyperactivity. *Psychol in the Schools* 1982;19:92-7.
137. Brown RT, Alford N. Amelioration attentional deficits and concomitant academic deficiencies in learning disabled children through cognitive training. *J Learn Disabil* 1984;17:20-6.
138. Sherman CF, Anderson RP. Modification of attending behavior in hyperactive children. *Psychol in the Schools* 1980;17:372-9.
139. Schrock RE. Introduction to vision training. Series 1-2, 1965- 67, OEP Foundation, Santa Ana, CA.
140. MacDonald LW. Visual training. Series 1-2. 1978-79, OEP Foundation, Santa Ana, CA.
141. Forrest EB. Visual imagery: An optometric approach. OEP Foundation, Santa Ana, CA, 1981.
142. Richman JE, Cron MT, Cohen E. Basic vision therapy: a clinical handbook. Big Rapids, Mich: Ferris State College Press, 1983.
143. Smith W. Clinical orthoptic procedure: A reference book on clinical methods of orthoptics. St. Louis: Mosby, 1950.
144. Borish IM. Clinical refraction. 3rd ed. Chicago: Professional Press, 1970:184-5.
145. Griffin JR. Binocular anomalies: Procedures for vision therapy, 2nd ed. Chicago: Professional Press, 1982:377-93.
146. Suchoff IB, Petito TG. The efficacy of visual therapy: accommodative disorders and non-strabismic anomalies of binocular vision.
147. Duane A. Anomalies of the accommodation, clinically considered. *Trans Am Ophthalmol Soc* 1915;1:386-402.
148. Duane A. Anomalies of the accommodation, clinically considered. *Arch Ophthalmol* 1916;45:124-36.
149. Pierce J, Greenspan S. Accommodative rock procedures in vision training, a clinical guide. *Optom Wkly* 1971;62(33):754-7.
150. Pierce J, Greenspan S. Accommodative rock procedures in vision training, a clinical guide. *Optom Wkly* 1971; 62(34):776-80.
151. Weisz CL. How to find and treat accommodative disorders. *Rev. Optom* 1983;120:48-54.
152. Zellers JA, Alpert TL, Rouse MW. A review of the literature and a normative study of accommodative facility. *J Am Optom Assoc* 1984;55:31-7.
153. Garzia R, Richman J. Accommodative facility: A study of young adults. *J Am Optom Assoc* 1982;53:821-4.
154. Bieber J. Why nearpoint retinoscopy with children? *Optom Wkly* 1974;65(3):54-7.
155. Apell R. Clinical application of bell retinoscopy. *J Am Optom Assoc* 1975;46:1023-7.

156. Levine S, Ciuffreda KJ, Selenow A, et al. Clinical assessment of accommodative facility in symptomatic and asymptomatic individuals. *J Am Optom Assoc* 1985;56:286-90.
157. Hoffman LG, Rouse, MW. Referral recommendations for binocular function and/or developmental perceptual deficiencies. *J Am Optom Assoc* 1980;51:119-26.
158. Hennessey D, Iosue R, Rouse M. Relation of symptoms to accommodative infacility of school-aged children. *Am J Optom Physiol Opt* 1984;61:177.
159. Daum K Accommodative dysfunction. *Doc Ophthalmol* 1983; 55:177-98.
160. Hoffman L. The effect of accommodative deficiencies on the development level of perceptual skills. *Am J Optom Physiol Opt* 1982;59:254-62.
161. Marg E. An investigation of voluntary as distinguished from reflex accommodation. *Am J Optom Arch Am Acad of Optom* 1951;28:347-56.
162. Randall R. Volitional control of visual accommodation. In: *Conf Proceedings, Advisory Group for Aerospace Research and Development*, 1970;82:15-7.
163. Provine R, Enoch J. On voluntary ocular accommodation. *Percept Psychophys* 1975;17:209-12.
164. Cornsweet TN, Crane H. Training the visual accommodative system. *Vision Res* 1973;13:713-5.
165. Prangen A. Subnormal accommodation. *Arch Ophthalmol* 1931;6:906-18.
166. Duane A. Anomalies of accommodation clinically considered. *Arch Ophthalmol (Old Series)* 1916;45:124-36.
167. Prakash P, Agarwal L, Nag S. Accommodational weakness and convergence insufficiency. *Orient Arch Ophthalmol* 1972; 10:261-4.
168. Von Noorden G, Brown D, Parks M. Associated convergence and accommodative insufficiency. *Doc Ophthalmol* 1973; 4:393-403.
- 168a. Hoffman L, Cohen AH. Effectiveness of nonstrabismic optometric vision training in a private practice. *Am J Optom Arch Am Acad Optom* 1973;50:813-6.
169. Liu JS, Lee M, Jang J, et al. Objective assessment of accommodation orthoptics: 1. dynamic insufficiency. *Am J Optom Physiol Opt* 1979;56:285-91.
170. Bobier WR, Sivak JG. Orthoptic treatment of subjects showing slow accommodative responses. *Am J Optom Physiol Opt* 1983;60:678-87.
171. Hung GK, Ciuffreda KJ, Semmlow JL. Static vergence and accommodation: population norms and orthoptic effects. *Doc Ophthalmol* 1986;62:165-79.
172. Duckman RH. The incidence of visual anomalies in a population of cerebral palsy children. *J Am Optom Assoc* 1979; 50:1013-6.
173. Duckman RH. Effectiveness of visual training on a population of cerebral palsied children. *J Am Optom Assoc* 1980;51:607-14.
174. Duckman RH. Accommodation in cerebral palsy: Function and remediation. *J Am Optom Assoc* 1984;55:281-3.



175. Haynes HM, McWilliams LG. Effects of training on near-far response time as measured by the distance rock test. *J Am Optom Assoc* 1979;50:715-8.
176. Weisz CL. Clinical therapy for accommodative responses: Transfer effects upon performance. *J Am Optom Assoc* 1979; 50:209-21.
177. Daum K. Accommodative dysfunction. *Doc Ophthalmol* 1983 55:177-98.
178. Daum K. Accommodative insufficiency. *Am J Optom Physiol Opt* 1983;60:352-9.
179. Daum K. Orthoptic treatment in patients with inertia of accommodation. *Aust J Optom* 1983;66:68-72.
180. Daum K. Predicting results in the orthoptic treatment of accommodative dysfunction. *Am J Optom Physiol Opt* 1984;61:184-9.
181. Borish IM. *Clinical refraction*. 3rd ed. Chicago: Professional Press, 1970:859-937.
182. Duke-Elder S. *System of ophthalmology, vol VI. Ocular motility and strabismus*. St. Louis: Mosby, 1973:513-76.
183. Griffin JR. *Binocular anomalies: procedures for vision therapy* 2nd ed. Chicago: Professional Press, 1982: 126-30.
184. Schor C, Ciuffreda KJ, eds. *Vergence eye movements: basic and clinical aspects*. Boston: Butterworths, 1983:1-538.
185. Burian H, von Noorden GK. *Binocular vision and ocular motility*. 2nd ed. St. Louis: Mosby, 1974:181-211.
186. Borish IM. *Clinical refraction*. 3rd ed. Chicago: Professional Press, 1970:327.
187. Burian H, von Noorden K. *Binocular vision and ocular motility*. 2nd ed. St. Louis: Mosby, 1974:167.
- 187a. Sheedy JE, Saladin JJ. Association of symptoms with measures of oculomotor deficiencies. *Am J Optom Physiol Opt* 1978;55:670-6.
188. Scobee R. *The oculorotary muscles*. 2nd ed. St. Louis: Mosby, 1952:160-8.
189. Duke-Elder S. *System of ophthalmology, vol v: Ophthalmic optics and refraction*, St. Louis: Mosby, 1970:479-87.
190. Lancaster JE. *A manual of orthoptics*. Springfield, IL: CC Thomas, 1951.
191. Dendy HM, Shaterian ET. *Practical ocular motility*. Springfield, IL: CC Thomas, 1967.
192. Hugonnier R, Hugonnier Sc. *Strabismus, heterophoria, ocular motor paralysis: clinical ocular muscle imbalance*. St. Louis: Mosby, 1969.
193. Gibson HW. *Textbook of orthoptics*. London: Hanon Press Ltd, 1955.
194. Hurtt J, Rasicovici A, Windsor CE. *Comprehensive review of orthoptics and ocular motility*. St. Louis: Mosby, 1972.
195. Berens C, Connolly P, Kern D. Certain motor anomalies of the eye in relation to prescribing lenses. *Am J Ophthalmol* 1933; 5:199-213.

196. Daum KM. The course and effect of visual training on the vergence system. *Am J Optom Physiol Opt* 1982;59: 223-7.
197. Daum KM. Convergence insufficiency. *Am J Optom Physiol Opt* 1984;61:16-22.
198. Daum KM. Classification criterion for success in the treatment of convergence insufficiency. *Am J Optom Physiol Opt* 1984; 61: 10- 5.
199. Daum KM. A comparison of the results of tonic and phasic training on the vergence system. *Am J Optom Physiol Opt* 1983;60:769-75.
200. Vaegan JL. Convergence and divergence show longer and sustained improvement after short isometric exercise. *Am J Optom Physiol Opt* 1979;56:23-33.
201. Vaegan JL, McMonnies C. Clinical vergence training. *Aust J Optom* 1979;62:28-36.
202. Vaegan JL. Convergence and divergence show large and sustained improvement after short isometric exercise. *Am J Optom Physiol Opt* 1979;56:23-33.
203. Pantano R. Orthoptic treatment of convergence insufficiency: A two year follow-up report. *Am Orthopt J* 1982;32:73-80.
204. Grisham J. The dynamics of fusional vergence eye movements in binocular dysfunction. *Am J Optom Physiol Opt* 1980; 57:645-55.
205. Grisham J. Treatment of binocular dysfunction. In: Schor C, Ciuffreda KJ, eds. *Vergence eye movements*. Boston: Butterworths, 1983:605-46.
206. Cooper J, Duckman R. Convergence insufficiency: incidence, diagnosis and treatment. *J Am Optom Assoc* 1918;49:673-80.
207. Cooper J, Feldman J. Operant conditioning of fusional convergence ranges using random dot stereograms. *Am J Optom Physiol Opt* 1980;57:205-13.
208. Cooper J, Selenow A, Ciuffreda KJ, et al. Reduction of asthenopia in patients with convergence insufficiency after fusional vergence training. *Am J Optom Physiol Opt* 1983; 60:982-9.
209. Dalziel CC. Effect of vision training on patients who fail Sheard's criterion. *Am J Optom Physiol Opt* 1981;58:21-3.
210. Wittenberg S, Brock FW; Folsom WC. Effect of training on stereoscopic acuity. *Am J Optom Arch Am Acad Optom* 1969; 46:645-53.
211. Saladin JJ, Rick JO. Effect of orthoptic procedures on stereoscopic acuities. *Am J Optom Physiol Opt* 1982;59:718-25.
212. Duke-Elder S. *System of ophthalmology, Vol VI. Ocular motility and strabismus*. St. Louis: Mosby, 1973:245-77.
213. Burian H, von Noorden GK, *Binocular vision and ocular motility*. 2nd ed. St. Louis: CV Mosby, 1974:175-274.
214. Parks M. Oculomotility and strabismus. In: Duane TD, ed. *Clinical ophthalmology*. Hagerstown, MD: Harper & Row, 1979:1.

215. Flax N. Strabismus diagnosis and prognosis. In: Schor C, Ciuffreda KF, eds. Vergence eye movements: basic and clinical aspects. Boston: Butterworths, 1983:579-95.
216. Flom MC. Treatment of binocular anomalies of vision. In: Hirsch MJ, Wick RE, eds. Vision of children. Philadelphia: Clinton, 1963:197-228.
217. Ludlam WM. Orthoptic treatment of strabismus. *Am J Optom Arch Am Acad Optom* 1961;38:369-88.
218. Ludlam WM, Kleinman BI. The long range results of orthoptic treatment of strabismus. *Am J Optom Arch Am Acad Optom* 1965;42:647-84.
219. Flax N, Duckman RH. Orthoptic treatment of strabismus. *J Am Optom Assoc* 1978;49:1353-61.
220. Gillan RU. An analysis of one hundred cases of strabismus treated orthoptically. *Br J Ophthalmol* 1945;29:420-8.
221. Guibor GP. Practical details in the orthoptic treatment of strabismus. *Arch Ophthalmol* 1934;12:887-901.
222. Guibor GP. Some possibilities of orthoptic training. *Arch Ophthalmol* 1934;11:433-61.
223. Guibor GP. The possibilities of orthoptic training-a further report. *Am J Ophthalmol* 1934;17:834-9.
224. Ziegler D, Huff D, Rouse MW. Success in strabismus therapy: a literature review. *J Am Optom Assoc* 1982;53:979-83.
225. Etting G. Strabismus therapy in private practice: Cure rates after three months of therapy. *J Am Optom Assoc* 1978; 49:1367-73.
226. Kertesz AE, Kertesz J. Wide-field stimulation in strabismus. *Am J Optom Physiol Opt* 1986;63:217-22.
227. Sanfilippo S, Clahane AC. The effectiveness of orthoptics alone in selected cases of exodeviation: the immediate results and several years later. *Am Orthopt J* 1970;20:104-17.
228. Altizer LB. The non-surgical treatment of exotropia. *Am Orthopt J* 1972;22:71-6.
229. Chryssanthou G. Orthoptic management of intermittent exotropia. *Am Orthopt J* 1974;24:69-72.
230. Goldrich SG. Optometric therapy of divergence excess strabismus. *Am J Optom Physiol Opt* 1980;57:7-14.
231. Van Brocklin MD, Vasche TR, Hirons RR, et al. Biofeedback enhanced strabismus therapy. *J Am Optom Assoc* 1981; 52:731-6.
232. Hirons RR, Yolton RL. Biofeedback treatment of strabismus: Case studies. *J Am Optom Assoc* 1978;49:875-82.
233. Afanador AJ. Auditory biofeedback and intermittent exotropia. *J Am Optom Assoc* 1982;53:481-3.
234. Goldrich SG. Oculomotor biofeedback therapy for esotropia. *Am J Optom Physiol Opt* 1982;59:306-17.
235. Flom MC, Kirschen DG, Bedell HE. Control of unsteady, eccentric fixation in amblyopic eyes by auditory feedback of eye position. *Invest Ophthalmol Vis Sci* 1980;19:1371-91.

236. Scheiman MM, Peli E, Libassi D. Auditory biofeedback used to enhance convergence insufficiency therapy. *J Am Optom Assoc* 1983;54:1001-3.
237. Pigassou-Albouy R. Use of prism in pre-operative and post-operative treatment. In: Fells P, ed. *The First Congress of the International Strabismus Assoc.* St. Louis: Mosby, 1971 :242- 75.
238. Berard PV: Constant wearing of prisms in treatment of concomitant strabismus. In: Ferrer OM, ed. *Int Ophthalmol Clin, Ocular Motility.* Boston: Little, Brown & Co, 1971:283-91.

## S) **The Scientific Basis For And Efficacy Of Optometric Vision Therapy In Nonstrabismic Accommodative And Vergence Disorders (AOA)\***

---

**Background:** For nearly 75 years, optometric vision therapy has been an important mode of therapy for both children and adults who manifested a range of nonstrabismic accommodative and vergence disorders.

**Methods:** In this article, the scientific basis for, and efficacy of, optometric vision therapy in such patients will be discussed. Using bio-engineering models of the oculomotor system as the conceptual framework, emphasis will be focused on studies that used objective recording techniques to directly assess therapeutically related changes in oculomotor responsivity.

**Results and Conclusions:** The findings clearly support the validity of optometric vision therapy. Furthermore, the results are consistent with the tenets of general motor learning.

**Key Words:** Accommodation, behavior modification, motor learning, oculomotor plasticity, oculomotor responsivity, vergence, vision therapy

Optometric vision therapy for nonstrabismic accommodative and vergence disorders involves highly specific, sequential, sensory-motor-perceptual stimulation paradigms and regimens. It incorporates purposeful, controlled, and scientifically based manipulations of target blur, disparity, and proximity, with the aim of normalizing the accommodative system, the vergence system, and their mutual interactions.<sup>1-3</sup> In addition, other sources of sensory information, such as kinesthesia<sup>4</sup> (e.g., touching the near test object) and audition<sup>5,6</sup> (e.g., oculomotor auditory biofeedback) correlated to the accommodative and vergence states (e.g., position, innervation, effort, etc.) can provide cue reinforcement. Inclusion of related behavioral modification paradigms,<sup>7-9</sup> such as general relaxation,<sup>5</sup> visual imagery,<sup>10,11</sup> (e.g., "think far or near"), and attentional shaping<sup>12</sup> may help one learn to initiate (i.e., provide a "trigger" mechanism) and/or enhance the appropriate motor responses. However, the ultimate goal of optometric vision therapy is not simply to impact positively on various aspects of the oculomotor system, in isolation, but to attain clear and comfortable binocular vision at all times. It involves oculomotor integration with the head (i.e., eye-head coordination),<sup>13</sup> neck (i.e., proprioceptive information),<sup>14</sup> limbs,<sup>15</sup> and overall body,<sup>16,17</sup> with information from the other sensory modalities, producing temporally efficient, coordinated behavior<sup>18,19</sup> within a context of harmonious spatial sense<sup>16,17,20</sup> under a variety of external and internal conditions and states.

### **Prevalence of nonstrabismic accommodative and vergence disorders**

Nonstrabismic accommodative and vergence disorders of a non-organic, nonpathological nature (i.e., "functional" in origin) are the most-common ophthalmic vision conditions (other than refractive error) that present in the general optometric clinical practice. The specifically related signs and symptoms may also initially be reported to, or uncovered by, the orthoptist, ophthalmologist, neurologist, internist, or general primary care medical practitioner, as well as others in the allied health and educational professions (e.g., school nurses, remedial reading teachers, etc.). Failure to detect and diagnose these problems may have grave consequences to some patients and, hence, legal consequences.<sup>21</sup>

In symptomatic, nonpresbyopic clinic patients, the prevalence of accommodative dysfunction and correlated symptoms is estimated at: accommodative insufficiency, 9.2%; accommodative infacility,

5.1%; and accommodative spasm, 2.5%.<sup>22</sup> However, as one might expect, in clinic patients who are receiving treatment for manifest binocular dysfunctions, the prevalence is much higher (60% to 80%).<sup>22,23</sup>

With respect to the prevalence of fusional vergence dysfunction, the most-common type is convergence insufficiency. The median prevalence is 7%, in both children and adults.<sup>24</sup> Other relatively frequent vergence dysfunctions include: convergence excess, 5.9% to 7.1%;<sup>22,25</sup> basic exophoria, 2.8%;<sup>26</sup> fusional vergence dysfunction, <7%;<sup>27</sup> and clinically significant vertical phoria, 9%.<sup>28</sup>

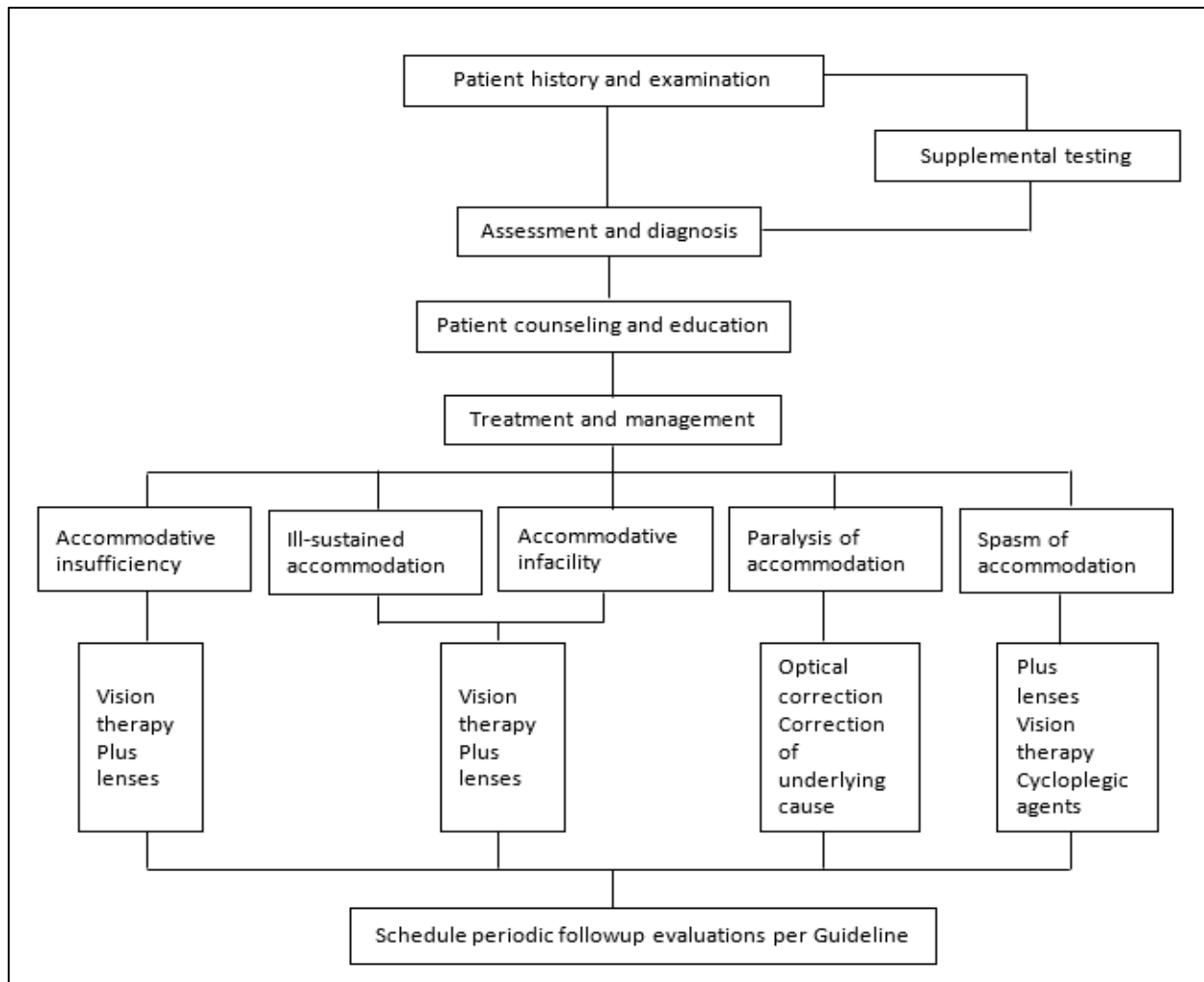
### **Symptoms reported in patients who manifest nonstrabismic accommodative and vergence disorders**

There are a wide range of symptoms reported in patients who manifest nonstrabismic accommodative and vergence disorders.<sup>26</sup> With respect to accommodation, these include: blurred vision at distance and/or near during or immediately following nearwork, headaches, poor concentration, and difficulty reading. With respect to vergence, these include: blurred vision, diplopia, ocular discomfort during or immediately following nearwork, frontal headaches, nausea, sleepiness, loss of concentration, heavy lid sensation, general fatigue, and "pulling" sensation of the eyes. Of interest, the symptom preventing tactic of task "avoidance" may be used by some, thus negatively impacting on overall quality of life—especially with respect to school and work performance.

### **Cure rates in patients who manifest nonstrabismic accommodative and vergence disorders**

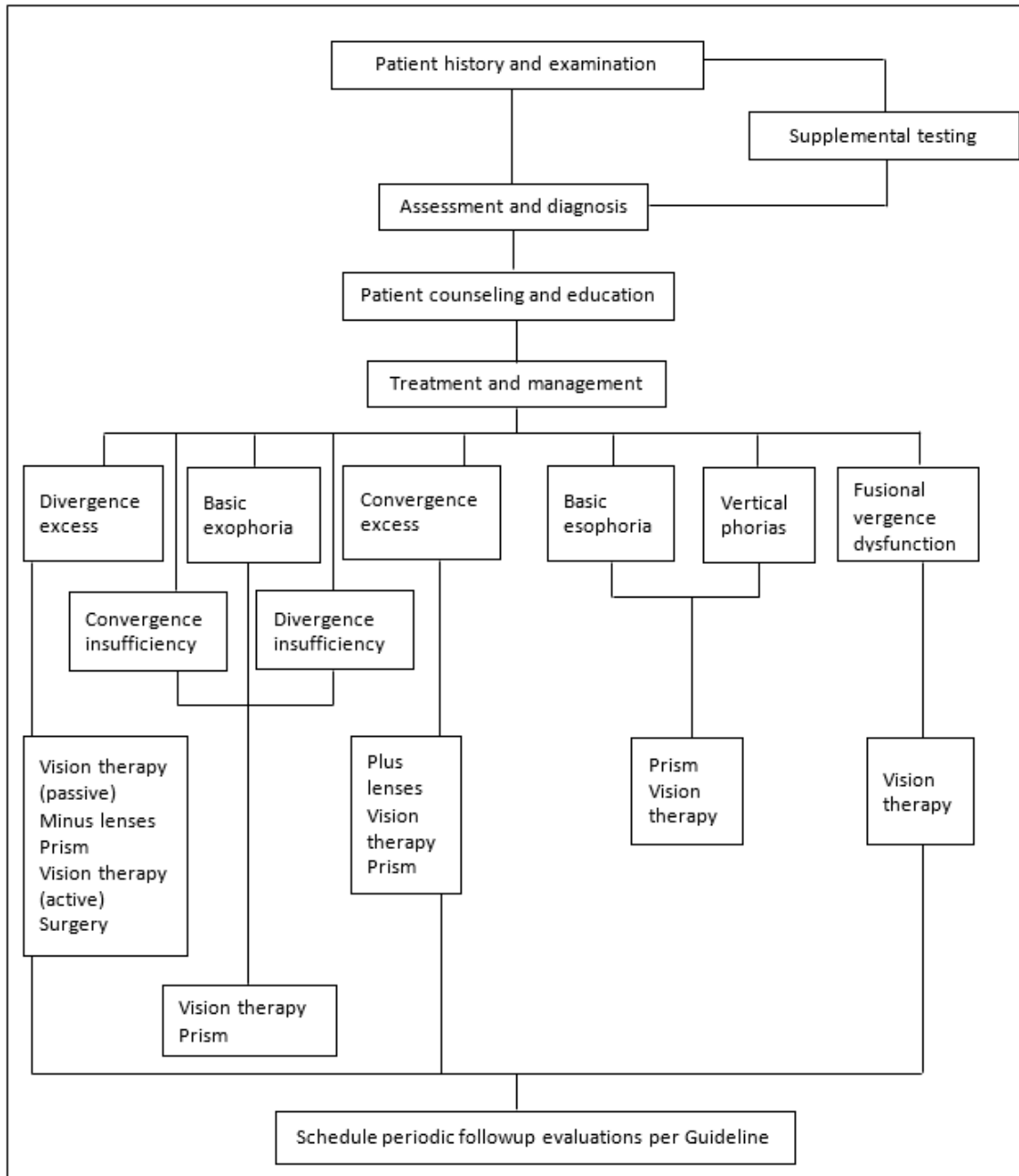
The cure rates in symptomatic patients who manifest nonstrabismic accommodative and fusional vergence disorders are very high (also see 'Accommodative Therapy' and 'Vergence Therapy' sections). Cure rates for accommodative disorders generally ranged from 80% to 100%,<sup>26</sup> and cure rates for vergence disorders generally ranged from 70% to 100%.<sup>26</sup>

The clinical practice of optometric vision therapy has had nearly 75 years to evolve to its present level within the optometric community.<sup>29-30</sup> Before that, however, its more narrowly focused counterpart of orthoptics was founded in France by the ophthalmologist Javal in the mid-nineteenth century (1858) and is still practiced widely—especially in Europe and the United Kingdom—in ophthalmological clinics.<sup>3</sup> In 1915, in the United States, Duane<sup>31</sup> reported that 10% of his ophthalmological clinic patients manifested nonpathological, functional, accommodative disorders that he believed could be remediated by accommodative "exercises" he proposed. Both optometrically based vision therapy and ophthalmologically based orthoptics have had a long history, and are currently actively involved in the successful management and treatment of a wide range of oculomotor dysfunctions, including those with nonstrabismic accommodative and vergence disorders. From this rich background, well-developed and scientifically based treatment plans with common elements have evolved—especially in optometry—to efficiently and cost-effectively remediate disorders of both of these oculomotor systems<sup>26</sup> (Figures 1 and 2). Clinical guidelines and important conceptual notions regarding these specific nonstrabismic accommodative and vergence disorders have evolved in optometry based on a wide range of laboratory, clinical, and epidemiologic investigations over the years.<sup>26,32-36</sup> All of these factors have contributed to keen insights and increased understanding of functionally based, nonstrabismic, accommodative and vergence disorders in clinical practice, resulting in the high success rates found following therapeutic intervention.



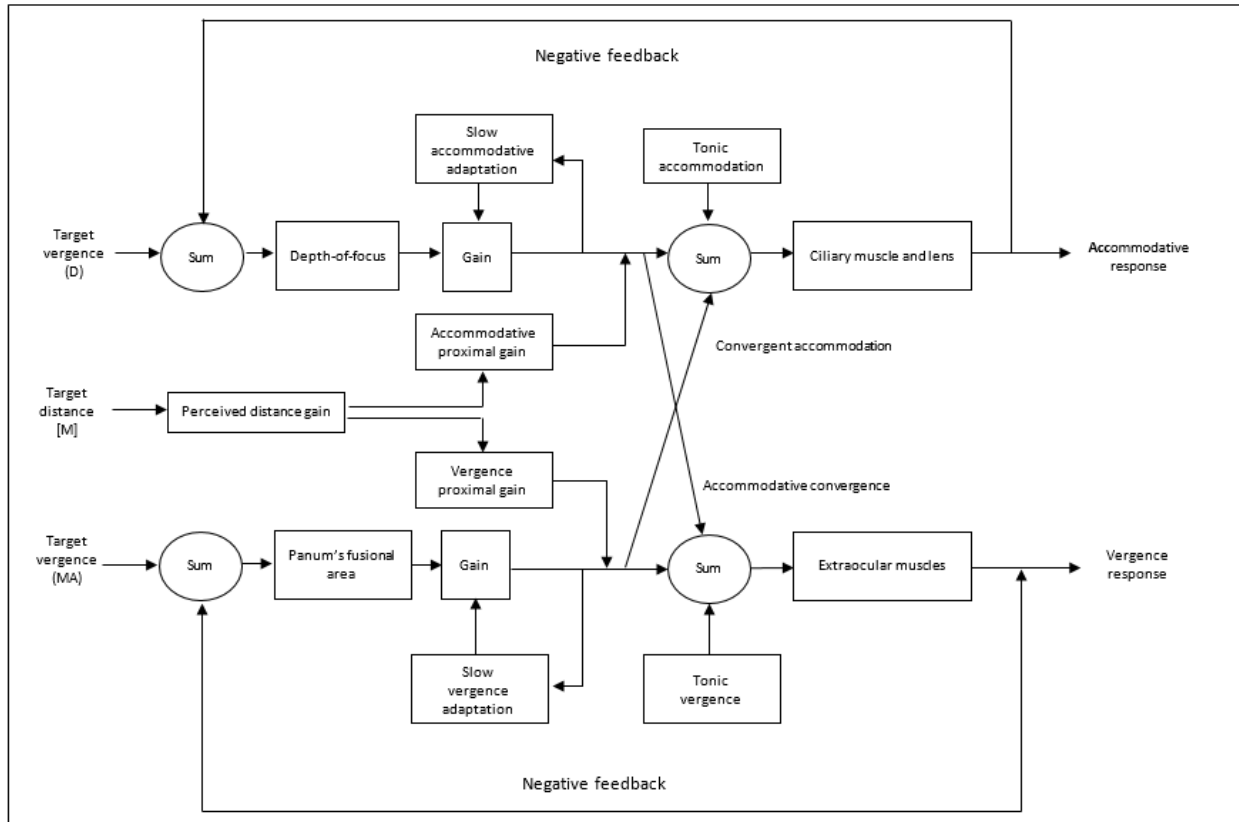
**Figure 1** Optometric management of the patient with accommodative dysfunction; a brief flowchart (reprinted with permission from the American Optometric Association, 1998).

The balance of this article will establish the scientific basis for, and efficacy of, optometric vision therapy. It will have the following organizational structure, using bio-engineering models of the oculomotor system as the conceptual framework, a detailed quantitative overview of various static and dynamic models of accommodation and/or vergence having a direct bearing on optometric vision therapy will be provided. In addition to specifying and describing these direct applications, the importance of models will be further developed in subsequent sections, selected research studies that provide support for the scientific basis for and efficacy of optometric vision therapy will be reviewed. The emphasis will focus on objective findings, although the results of other carefully conducted clinical investigations will be considered. And, more global aspects will be considered, including the relationship between vision therapy, general motor learning, and oculomotor plasticity.



**Figure 2** Optometric management of the patient with vergence dysfunction; a brief flowchart (reprinted with permission from the American Optometric Association, 1998).

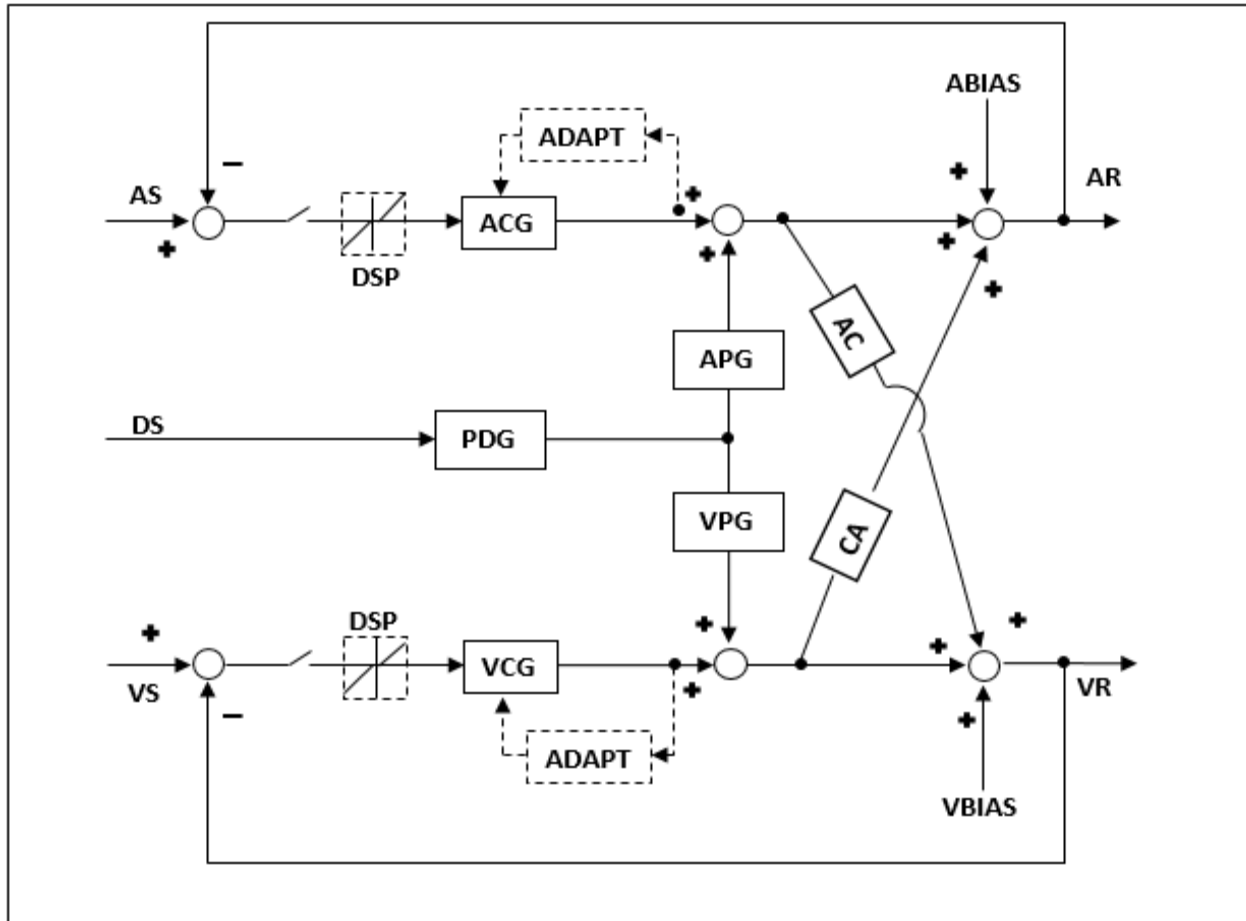




**Figure 3** Simplified, conceptual model of Hung et al., 1996 (reprinted with permission, from Ong and Ciuffreda, 1997.)

### Models of the accommodative and vergence systems

Various static and dynamic models of the accommodative and vergence systems have been proposed over the past 50 years.<sup>37-53</sup> Models provide a comprehensive, organizational framework for logical thinking and conceptual understanding of a system's elemental components within the context of its overall structural framework, especially as the body of knowledge increases. By considering individual components, one can understand when specific system aspects are abnormal prior to vision therapy, which aspects normalize subsequent to vision therapy, and how vision therapy itself may be specifically tailored based on the overall model structure. All of these points will be addressed to some extent in subsequent sections of this article. Models also allow non-invasive, "dry dissection" and testing of a system and its underlying neurological control structure by performing computer simulations incorporating a variety of mathematical techniques. For example, sensitivity analysis<sup>49</sup> allows one to ascertain the likelihood of a specific oculomotor system component being responsible for the observed anomalous response pattern. As an illustration, it was found that the oculomotor gain control components were most sensitive to variation in model parameter values, as gain terms effectively multiply the incoming system error information.



**Figure 4** Complete nonlinear static interactive dual-feedback model of the accommodative and vergence systems. For the system, the switch controls feedback to accommodation. With the switch open, the input to the accommodative dead-space operator (which represents the depth-of-focus) is effectively zero. On the other hand, with the switch closed, the difference between accommodative stimulus ( ) and accommodative response ( ), or accommodative error, is input to DSP. The output of DSP is multiplied with the accommodative controller gain ( ) to give the accommodative controller output. The controller output is input to an adaptive element ( ), which in turn controls the time constant of the accommodative controller. The distance stimulus ( ), or the distance of the target from the viewing subject, is input to the perceived distance gain ( ) element, which represents the subjective apparent distance estimate. The PDG output then goes through the accommodative proximal gain ( ) element, which represents the contribution from target proximity. The outputs from ACG and APG are summed at the summing junction and are also crosslinked to the vergence system via gain AC. The accommodative bias ( ), or tonic accommodation, is summed at the next summing junction, along with the crosslink signal from the vergence controller output via CA. These four signals are added together to give the overall accommodative response. Analogous descriptions of the parameters are applicable for the system. (Reprinted with permission from Hung et al.,1996).

Thus, small variations in, or deviations from, the norm would be predicted to have large effects on system response amplitude-i.e., either being excessive or insufficient.

However, few models have met three basic requirements:

1. model parameter values that agree with empirically derived physiologic data,
2. computer-simulated responses-especially dynamically-to a variety of inputs (such as pulses, steps, ramps, and sinusoids) that agree with the empirically derived physiologic data, and

- homeomorphic model structure that therefore reflects the underlying anatomy and physiology. All of the models to be discussed fulfill these basic requirements.

**Table 1: Static model values for accommodation and vergence**

<b>Accommodation</b>	<b>Vergence</b>
<b>DSP = ± 0.15 D</b>	<b>PFA = ± 5.0 min arc</b>
<b>ACG = 10.0</b>	<b>VCG = 150</b>
<b>AC = 0.80 D/MA</b>	<b>CA = 0.37 MA/D</b>
<b>ABIAS = 0.61 D</b>	<b>VBIAS = - 0.29 MA</b>
<b>ADAPT = 4.0</b>	<b>ADAPT = 9</b>
<b>APG = 2.10</b>	<b>VPG = 0.067</b>
<b>PDG = 0.212</b>	<b>PDG = 0.212</b>

(See text for explanation and description of abbreviations. Also see related figures/figure legends.)

### Static model of the accommodative and vergence systems

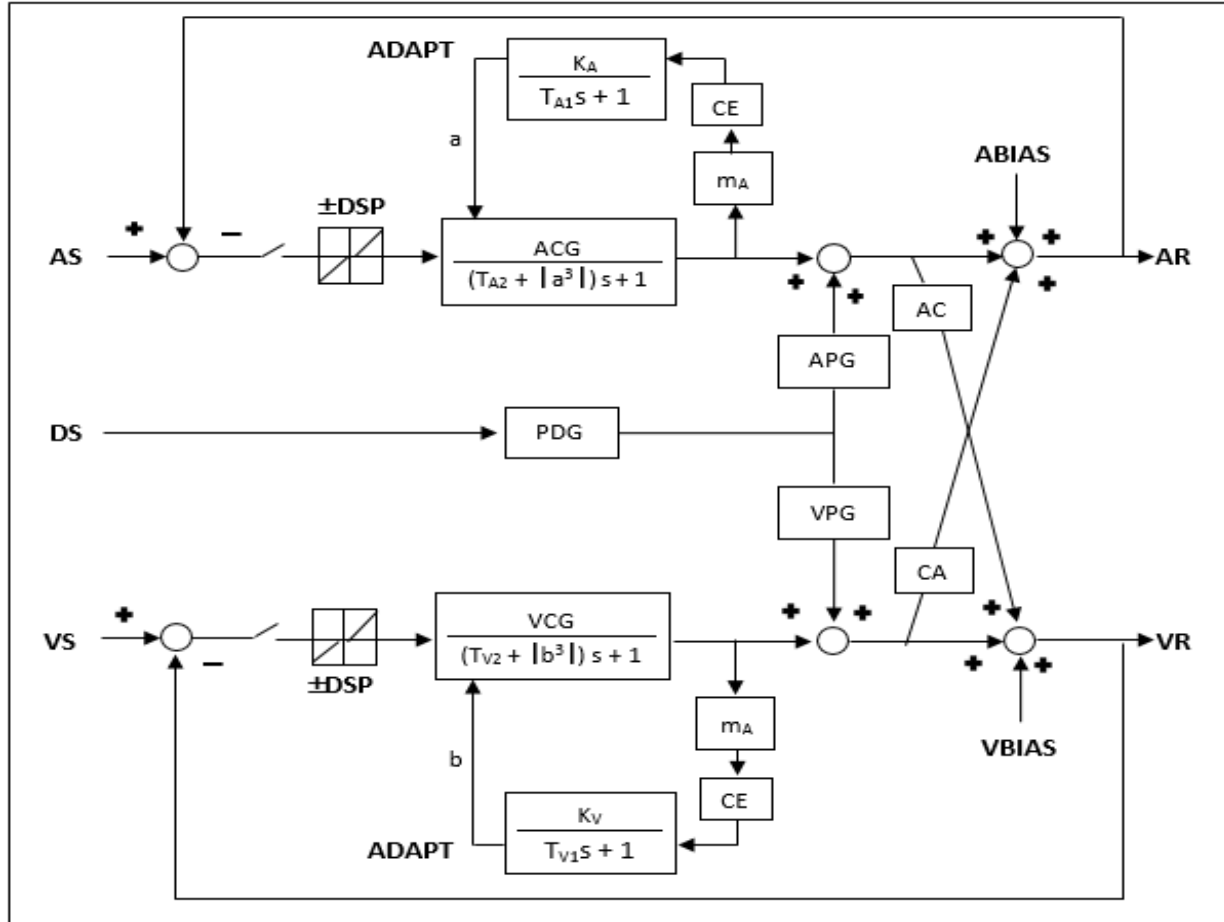
A useful static, or steady-state, model of the accommodative and vergence systems and its motor interactions by Hung and his colleagues<sup>46,47,53</sup> has evolved over the past 20 years. This model and its variations have been useful for furthering our understanding of a wide range of basic mechanisms<sup>53</sup> (e.g., vergence and accommodative adaptation), as well as their application to a range of important clinical conditions (i.e., amblyopia,<sup>54,55</sup> strabismus,<sup>56</sup> nystagmus,<sup>57</sup> myopia,<sup>58</sup> and vergence and accommodative dysfunction<sup>49</sup>). For example, after completion of a dynamic vergence response from far to near, the static model specifies the resultant steady-state error for accommodation (e.g., lag of accommodation as assessed clinically with the retinoscope) and vergence (e.g., fixation disparity as assessed clinically with a disparometer), and allows the modeller to vary the internal, neurologically based control parameters to predict and assess the impact on system errors. A conceptual version of their latest model is presented In Figure 3.<sup>59</sup>

This latest version, transformed into the bio-engineering domain, is presented in Figure 4,<sup>47</sup> with parameter values presented in Table 1. Progressing from left to right in the figure, it may be seen that the accommodative ( ) and vergence ( ) negative feedback control loops have similar component structures.

The input or stimulus change for accommodation (AS) (target distance in diopters) and disparity vergence (VS) (target distance in meter angles, MA) sum algebraically with the negative feedback response of the respective system at that moment. The resultant difference represents the system's initial error (AE or VE, respectively). The input for the proximal branch is perceived target distance, with such perceptually derived proximal information not having a separate feedback loop, but rather inputting directly and simultaneously into both the accommodative and vergence feedback loops. Under normal binocular, closed-loop (i.e., with blur and retinal disparity feedback present) viewing conditions, the proximal drive only adds 0.4% and 4% to the final steady-state vergence and accommodative responses, respectively.<sup>47</sup>

This represents the depth-of-focus for accommodation and Panum's fusional areas for disparity vergence. This component allows small neurosensory-based system error (i.e., retinal defocus and

retinal disparity, respectively) to be tolerated without adverse perceptual consequences (i.e., blur and diplopia, respectively). If the input error exceeds its threshold level, this error information proceeds to drive the respective system. However, even if the vergence error does exceed the deadspace, a large residual fixation disparity may adversely affect visual performance or cause a small foveal binocular suppression scotoma to develop.



**Figure 5** Comprehensive, dual-interactive, static model of the accommodative and vergence systems, with inclusion of dynamic adaptive components. Consider first the accommodative loop. The deadspace element ( $\pm DSP$ ) represents the neuro-optical DOF. The controller output is multiplied by factor  $m_A$  and input to a tanh function which serves as a compression element (CE). The factor  $m_A$  is used to provide an appropriate range on the abscissa of the tanh function. The CE reduces the controller output for large magnitude inputs so that the adaptation effect is not drastically different at various adapting stimulus levels. The adaptive component is represented by the first-order dynamic element  $\frac{1}{T_{A1}s + 1}$  in which  $T_{A2}$  is the accommodative adaptation time

Constant. The accommodative adaptation gain,  $K_A$ , controls the magnitude of the adaptive component output level. The adaptive element output,  $a$ , modifies the time constant of the accommodative controller via the term,  $T_{A2} + [a^3]$ , in which  $T_{A2}$  is the fixed portion of the time constant. The cubic relationship was obtained empirically to provide a negligible increase in time constant for a small amount of adaptation, but very long time constant for a large amount of adaptation. A similar configuration applies to the vergence system, where the deadspace element ( $\pm DSP$ ) represents PFA. The vergence adaptive components consist of multiplier  $m_v$ , compression element CE, adaptive gain  $K_v$ , adaptive time constant  $T_{v1}$ , adaptive element output  $b$ , and controller time constant  $T_{v2} + [b^3]$ . (Reprinted with permission from Hung and Ciuffreda, 1999).

The accommodative ( $ACG = \frac{AR - ABIASJ}{AE - DSP}$ ) and vergence ( $VCG = \frac{VR - VBIAS}{VE - DSP}$ ) controller gains represent the experimentally derived, open-loop, internal neurological controller gains of the respective systems. The final system error signal, which equals the initial system error minus the deadspace threshold value, is multiplied by this gain element. Its output provides the majority of the neurological control signal to formulate the final steady-state motor response. For example, an abnormally high accommodative controller gain would result in accommodative excess, whereas an abnormally low gain would result in accommodative insufficiency.

The output of the controller gain is then input to three other components (see next three components below).

### Adaptive gain loop

Although typically regarded to be a dynamic model element, following intense and prolonged nearwork, it may bias the final, static open-loop or closed-loop system response. However, under nonsustained viewing conditions, its value is zero (see later dynamic model section).

### Crosslink gain

The crosslink gain (AC for accommodation and CA for convergence) multiplies the output of the direct ACG or VCG pathway, respectively. For accommodation, this new value represents the effective accommodative-convergence to accommodation ( $\frac{AC}{A}$ ) ratio, whereas for convergence it represents the

effective convergence-accommodation to convergence ( $\frac{CA}{C}$ ) ratio.

### Tonic input

Tonic input for accommodation (ABIAS) and vergence (VBIAS) has been speculated to reflect low-level, stable midbrain baseline neural innervation, although other brain regions may be involved. Although both the tonic vergence and accommodative terms have substantial effects on the response amplitude with both systems rendered open-loop (i.e., with their visual feedback rendered ineffective), they have negligible influence on the overall closed-loop near response and only modest influence on the closed-loop far response.<sup>46</sup>

This is shown in the following equation and example with respect to monocular blur-driven accommodation, in which:

$$AR = \frac{ACG}{1+ACG} \times AS + \left[ -DSP \times \frac{ACG}{1+ACG} + ABIAS \times \frac{1}{1+ACG} \right]$$

For a typical value of ABIAS = 1 diopter and ACG = 9, the effect of ABIAS on AR would only be 0.1 diopter (D). This relative lack of effect is even more dramatic for disparity vergence (with its much higher controller gain value) with accommodation open-loop, in which:

$$VR = \frac{VCG}{1+VCG} \times VS + \left[ -DSP \times \frac{VCG}{1+VCG} + VBIAS \times \frac{1}{1+VCG} \right]$$

For a typical value of VBIAS = 1 MA and VCG = 149, the effect of VBIAS on VR would only be 0.007MA.

### Summing junction

The direct gain output is also sent to the neuro- logical summing junction, where it adds with the crosslink output and the tonic input, both of which have only modest-to-moderate influence on the fellow system, to formulate the final combined signal to drive the respective system. This summing junction may reside in the midbrain.

### **Peripheral apparatus**

The output of the summing junction proceeds to cortical and subcortical centers related to accommodation<sup>60,61</sup> and vergence<sup>51</sup> to formulate the aggregate neural signal. It then advances to innervate the appropriate peripheral apparatus—the ciliary muscle and lens complex for accommodation and the extraocular muscles for vergence.

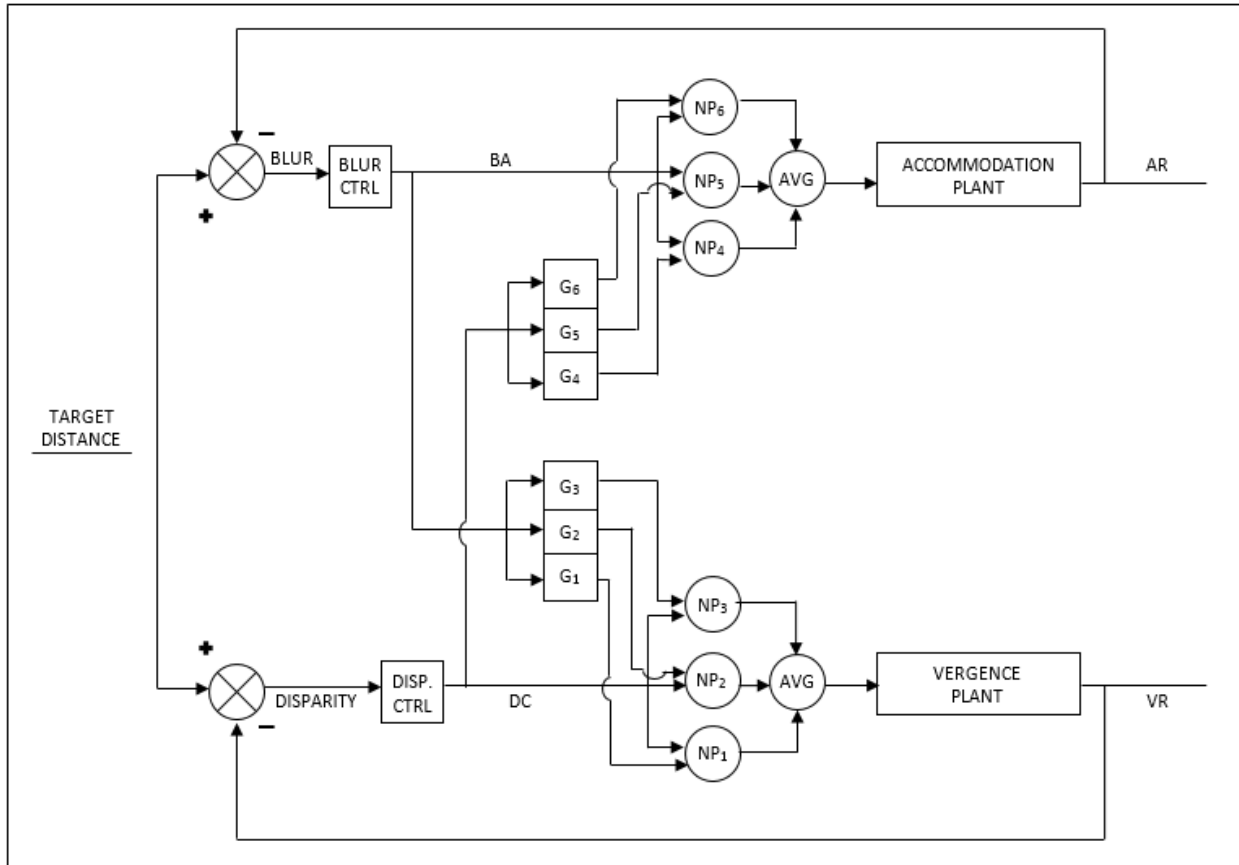
### **Output**

These motor changes are then fed back to the initial summing junction via the negative-feedback pathways. If a relatively large residual error remains, the cycle is repeated, until an acceptably small and stable steady-state error for both systems is attained. If the error cannot be reduced for whatever reason, such as low vergence controller gain, however, then diplopia would result; for accommodation, the outcome would be sustained blur.

### **Incorporation of adaptive dynamic components into the model**

In addition to the basic dual-interactive static components described above, adaptive dynamic gain components were more-recently incorporated into the accommodative and vergence controllers for establishment of a new dynamic, time-dependent, nearwork oculomotor model<sup>53,59</sup> (Figure 5). The adaptive loops function to sustain the motor response for a prolonged period (i.e., several seconds or minutes); for example, during reading. The adaptive gain element in each feedback loop receives its input signal from the controller (ACG or VCG) output, with the adaptive loop output in turn modifying the time constant of the controller via terms ' ' and ' ' for the accommodative and vergence loops, respectively. For example, the accommodative controller output (ACG) is input to a multiplier ( $m_A$ ) and compression element (CE) to drive the adaptive element having gain ( $K_A$ ) and time constant ( $T_{A1}$ ).

The multiplier and compression elements are necessary to provide a saturation effect for large inputs that are found in the various adaptation experiments. The adaptive element output, ' ', is incorporated into and modifies the overall time constant of the accommodative controller via the term,  $T_{A2} + [a^3]$ , in which  $T_{A2}$  is the fixed portion of the time constant. The cubic relationship was obtained empirically to provide negligible increase in the time constant for smaller amounts of adaptation, but a larger increase in the time constant for greater amounts of adaptation. Similar to the accommodative adaptive element, the vergence adaptive component consists of multiplier,  $m_v$ , compression element, CE, adaptive gain,  $K_v$ , adaptive time constant,  $T_{V1}$ , adaptive element output, 'b', and controller time constant,  $T_{V2} + [b^3]$ .



**Figure 6** Neurophysiological version of static accommodative and vergence model of Hung and colleagues. Symbols:  $\otimes$  = blur-driven accommodation,  $\oplus$  = disparity-driven convergence,  $\circ$  = midbrain near response cells,  $\square$  = midbrain near response cell gains,  $\square$  = accommodative response, and  $\square$  = vergence response. (Reprinted with permission from Mays and Gamlin, 2000). For Figures 3, 4, 5, and 6, see text for explanation of symbols.

### Neurophysiological version of static model of the accommodative and vergence systems

Recently, a neurophysiologically based configuration of the basic Hung and et al.'s<sup>45,47</sup> static model of the accommodative and vergence system has been proposed<sup>63</sup> (Figure 6; compare with Figure 4). All of the intermediary block elements of the earlier static control system models described have been replaced by their neurological analogs—namely, gains (G), near response cells (NR), and neural averagers (AVG). Hence, the bioengineering models described earlier are indeed homeomorphic, and thus have true neurophysiological representation, albeit somewhat spartan at the present time. However, no simulations have been performed using this model.

### Dynamic models of accommodation

Figure 7 presents a dynamic model of the accommodative system. This model is adapted from Krishnan and Stark (1975).<sup>43</sup>

The various model elements—progressing from left to right in the figure—are discussed below (also see the legend for symbols and additional information).

(u)

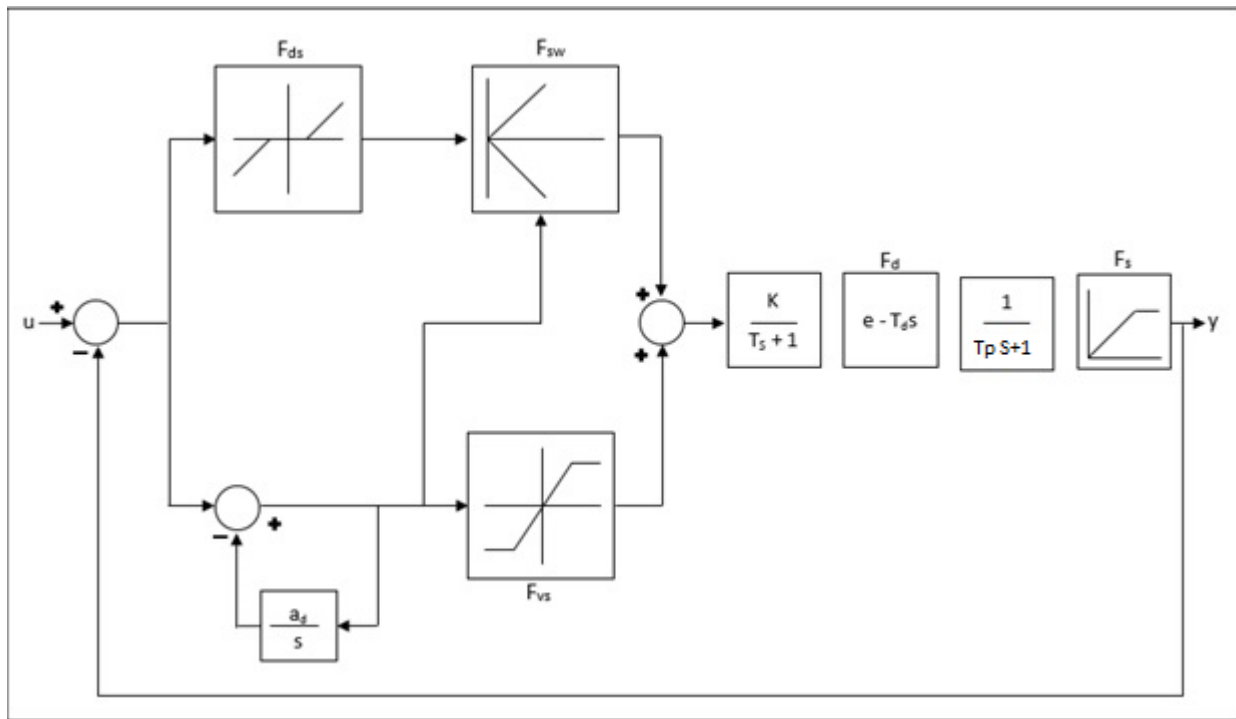
The input is target accommodative stimulus level; that is, the target distance in diopters. It sums with the instantaneous accommodative level of the system via the negative-feedback loop. The difference represents the resultant system error.

( $F_{ds}$ )

This represents the depth-of-focus, which allows for a small neurosensory-based system error and resultant retinal defocus to be tolerated without the perception of blur.

If the input error exceeds this threshold level, it proceeds to drive the system.

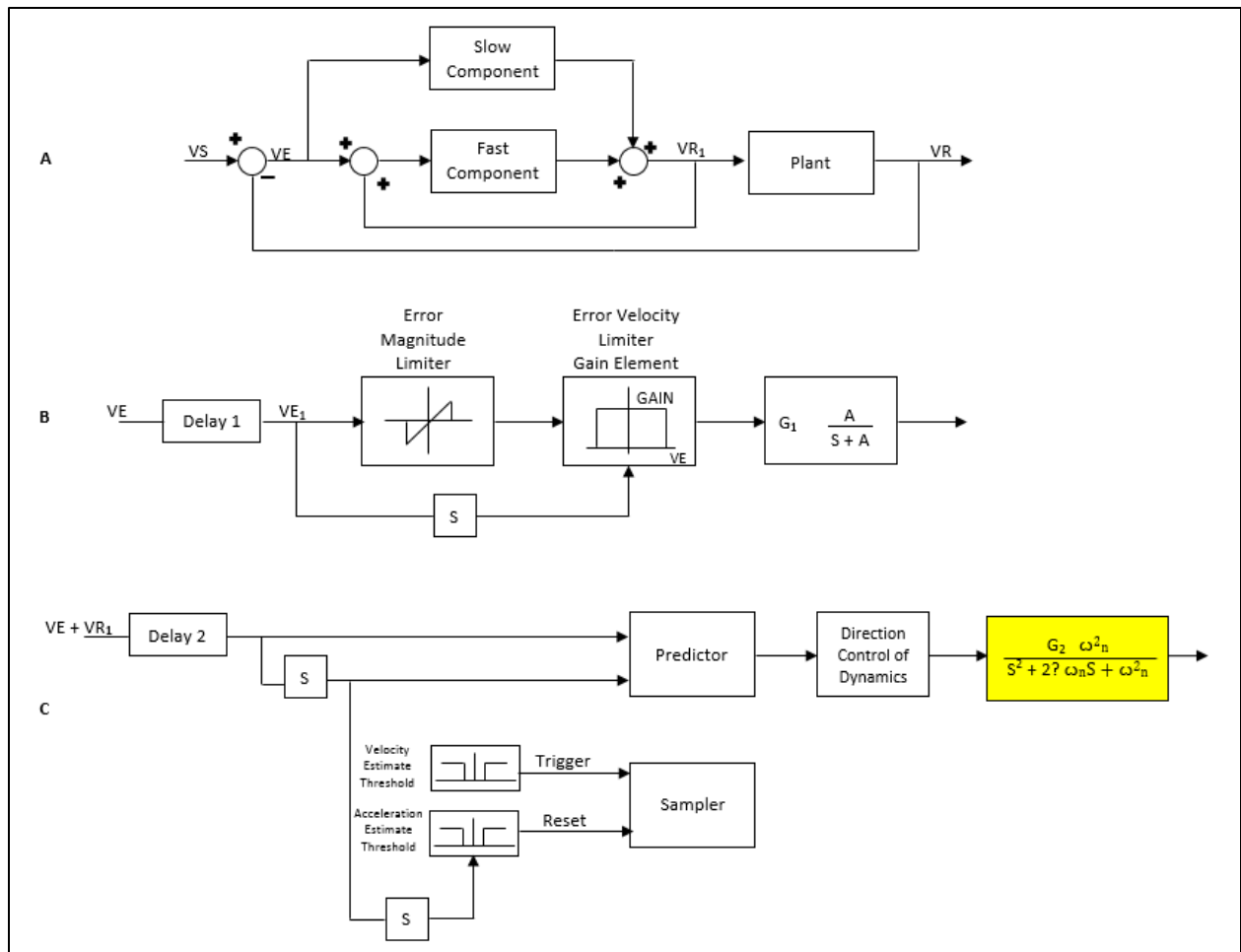
( $F_{sw}$ )



**Figure 7** Simplified version of Krishnan and Stark's (1975) dynamic model of accommodation. Symbols:  $F_{ds}$  depth of focus;  $F_{sw}$ , switching component (even-error component);  $F_{vs}$ , velocity-sensitive saturation, or velocity operator, which limits the velocity change;  $u$ , input;  $\frac{a_f}{s}$  lead/lag term (quasi-derivative controller, or velocity operator;  $a_d = 10$  and involves dynamics and stability);  $F_s$ , accommodative amplitude, or "plant" saturation;  $K$ , gain;  $T_p$ , time constant or decay for the accommodative peripheral apparatus ("plant") = 0.4 sec;  $F_d$ , time delay =  $e^{-t_d s}$ , in which  $T_d$  = accommodative latency = 0.38 sec;  $y$ , output;  $\frac{1}{s}$  integrator;  $\frac{1}{1+T_s s}$  leaky, integrator;  $t$ , neural time constant, or accommodative decay = 1- sec (reprinted with permission from Krishnan and Stark, 1975).

Because blur is an even-error signal (i.e., it lacks directional information),<sup>39</sup> this element uses the sign information from the derivative operator to determine its direction. It generates a signal that is directionally- correct and proportional to the magnitude of blur.





**Figure 8** Overall, dynamic model of disparity vergence system shows slow and fast components in the forward loop. Slow and fast component responses are summed to give  $VR_1$ . Internal positive feedback from  $VR_1$  is summed with vergence error ( $VE$ ) to give an estimate of target position.  $\frac{A}{S+A}$  represents mechanical properties of eyeball and musculature and is assumed to have unity gain ( $=1$ ) for the vergence simulation. Vergence response ( $VR$ ) is subtracted from vergence stimulus ( $VS$ ) to give vergence error ( $VE$ ). Slow component in forward loop: delayed vergence error ( $VE_1$ ) is vergence error ( $VE$ ) delayed by 200 msec (delay 1). Error magnitude limiter (up to 1 degree) and error velocity limiter gain element (up to 2 degrees/sec) simulate range of slow component dynamics. Time constant  $1/A$  is 10 seconds. Gain ( $G_1$ ) was determined via simulation to be 30.  $VE$ , velocity;  $A$ , reciprocal of the time constant;  $S$ , Laplace operator;  $\frac{1}{S}$ , differentiator.

Fast component in forward loop; vergence error ( $VE$ ) is summed with  $VR_1$ , to give an estimate of target position. Delay element (delay 2) represents effective delay throughout fast component. Estimated target velocity above a threshold of 1.7 degree/sec is used to trigger sampler. Sampler enables predictor to use estimated target position and velocity to predict future position of, for example, a ramp stimulus. After triggering, threshold increases slightly to 2.1 degrees/sec. This accounts for initial step but subsequent smooth following seen in response to a 1.8 degree/sec ramp stimulus. If estimated stimulus velocity remains constant, sampler repeats every 0.5 second. This accounts for staircase, steplike responses to ramp stimuli. Sudden large changes in velocity will reset sampler. This accounts for ramp-pulse data. Predictor also reduces its calculation time, thus reducing delay 2, for repetitive stimuli, such as sinusoids. This accounts for relatively small phase-lag found in sinusoidal responses (reprinted with permission from Hung et al., 1986).

**Derivative controller ( $\frac{a_d}{S}$ )**

This parallel, pseudo-derivative (i.e., a mathematical approximation to a true derivative) controller component is a velocity operator. It generates the derivative of the error signal (i.e., the instantaneous velocity) for use by its control process. Such a controller improves the transient stability; as well as the speed, of the response.

$$(F_v)$$

This element is a velocity-sensitive component that prevents the resultant response velocity from exceeding a specified limit.

$$\frac{(1)}{1+Ts}$$

The "leaky" integrator is a "charge/discharge" element. It represents a central neurological integrating circuit that is rapidly activated ("charged" like a capacitor) by the visual input which then "stores" this information, thus providing steady-state maintenance of the response. "Discharge" of this element is reflected in the decay rate, or reciprocal of the time constant, of the system dynamics.<sup>64</sup>

$$(F_d)$$

This represents the combined neural and bio-mechanical transmission time delays, or latency/reaction time, with this perhaps also involving attentional and/or predictive aspects.

$$\frac{(1)}{T_pS + 1}$$

This represents the biomechanical response characteristics of the combined ciliary muscle/lens zonules/lens/lens capsule complex, or "plant".

$$(F_s)$$

The saturation element limits the accommodative response imposed by the lens elasticity and related structures.

$$(y)$$

This represents the accommodative system's final output. It is transmitted back to the input via the negative feedback loop, where it is subtracted from the current input level. If a relatively large residual error remains, the cycle is repeated until an acceptable error is attained.

A different dynamic model, one in which the dual-mode control characteristics were emphasized, was developed by Hung and Ciuffreda (1988).<sup>48</sup> The rationale for a system having "dual-mode" control—i.e., having "fast" and "slow" dynamic control components—is to provide overall system stability in a feedback loop that has a relatively long latency (i.e., equal to or longer than the dynamic step response latency).

Based on monocular accommodative tracking responses to ramps (i.e., constant velocity blur-only stimuli), as well as computer simulations, it was concluded that the accommodative system operated in two basic modes, "fast" and "slow", and hence the term control. The "fast" component is used to track rapidly moving (> 2.0 D/sec), constant-velocity ramp stimuli, as well as instantaneous steps of blur. This "fast" component is preprogrammed and thus open-loop in nature, and does not use visual feedback

related to blur of the retinal image during its initial dynamic trajectory. By contrast, the "slow" component is used to track slowing-moving ( $\leq 0.5$  D/sec) ramp stimuli, as well as to correct small, residual errors remaining in the step tracking response. This "slow" component is closed-loop in nature, and thus uses visual feedback related to blur of the retinal image during its dynamic trajectory. And for intermediate velocity ramps of blur stimuli, a mixture of ramp-like and step-like motor responses are intermingled.

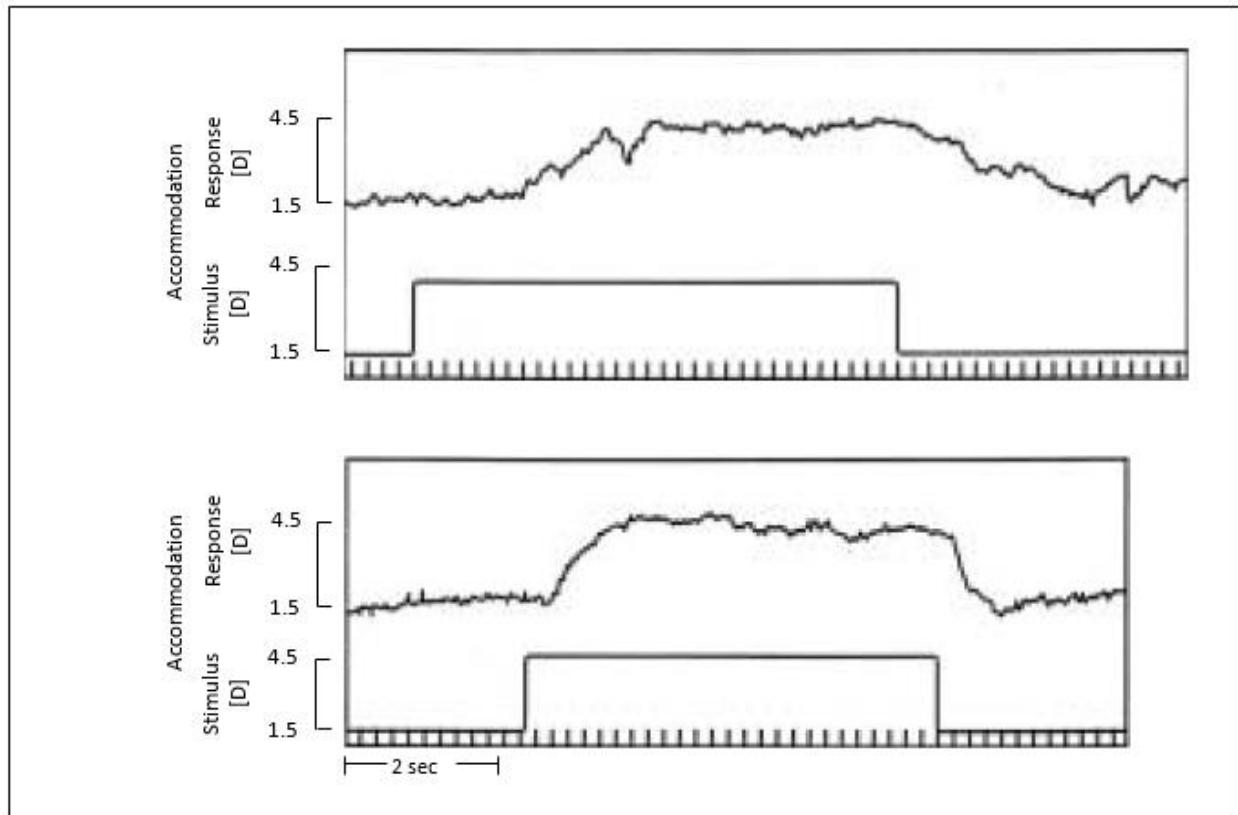
Thus, for a typical blur-driven, accommodative step response, the "fast" component is responsible for the initial (300 to 500 msec) and large open-loop, exponentially characterized portion of the motor response, whereas the "slow", visual feedback-driven, closed-loop component is responsible for completion of the response (500 to 700 msec) to attain clear retinal imagery lying within the depth-of-focus of the eye.

### **Dynamic model of disparity (fusional) vergence**

A dynamic model<sup>45</sup> of disparity vergence is presented in Figure 8.

The current model has two major subdivisions or components analogous to those proposed earlier for accommodation:

1. The "fast" component is used to track perceived target velocity (with a latency/ reaction time or delay of 200 msec) of rapidly moving targets ( $> \sim 2$  degrees/sec), such as occurs with rapid ramps, fast sinusoids, pulses, and the more-common and naturalistic steps of disparity input. Rather than using continuous visual feedback—as earlier simple servomechanism-based models had assumed—the fast component is preprogrammed or open-loop, and it is triggered by, and then samples, the rapidly moving target. Its direct feed-forward pathway dynamically represents the "fast" subsystem. That is, this complex is responsible for generating the initial 300 to 500 msec or so of the response to a disparity input and accounts for most of the overall response amplitude. A predictor operator then predicts future target position, such as where it will be 500 msec later based on estimated target position and velocity at the time of sampling, and subsequently sends a command to make such a motor response. The fast component's motor response approximates an exponential.
2. The "slow" component is used to track slowly-moving targets ( $< \sim 2$  degrees/sec), as well as small residual errors remaining in the step tracking response. It is driven by vergence error (with a delay of 50 msec for predictable stimuli and 200 msec for nonpredictable stimuli). Thus, in contrast to the open-loop, nonvisual feedback neurological control structure and response of the initial fast component described above, the slow component incorporates a closed-loop response. Since the slow component uses continuous visual feedback, it functions to correct any slow and small residual or accumulating vergence error ( $< 1$  degree amplitude,  $< 1.8$  degrees/sec velocity), especially following slightly inaccurate and rapid open-loop fast component step responses, or also fast-ramp responses. Note that this slow component is to be confused with the "slow" adaptive dynamic gain element discussed earlier, which is responsible for long-term decay following prolonged nearwork.



**Figure 9** Accommodation responses of subject records show slow response dynamics for positive accommodation and slow, multiphasic response dynamics for relaxation of accommodation before orthoptic training. Records show the patient's improvement after training with faster velocities in both directions of accommodation. Note two discontinuous spikes in the upper record when the patient blinked; stimuli for each are unpredictable step changes between targets set at 1.5 and a 4.5 D (reprinted with permission from Liu et al., 1979).

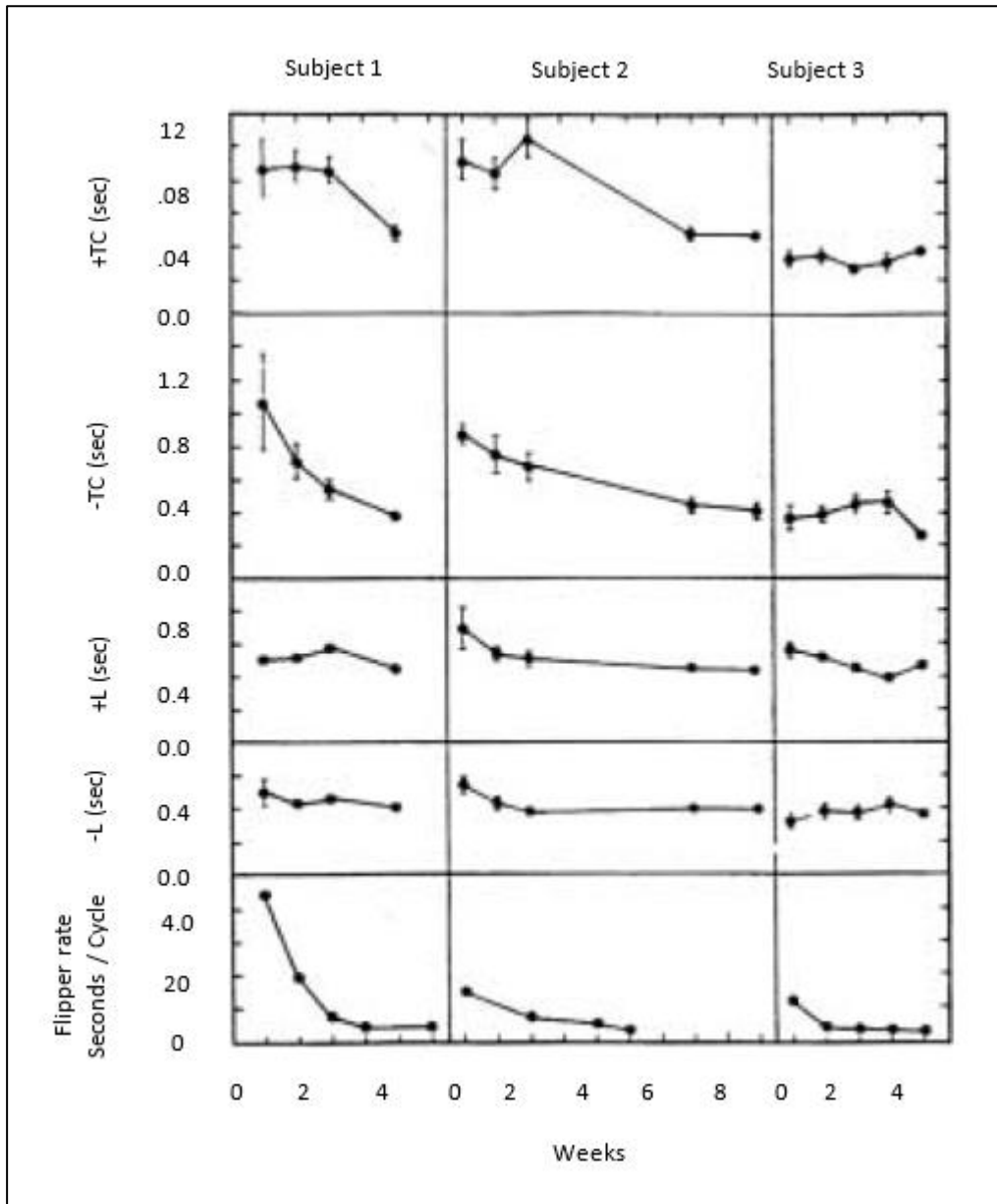
## Accommodative therapy

### Primary studies

There have been three primary studies conducted over the past 20 years or so that have clearly demonstrated the efficacy of accommodative therapy in patients who manifested combined accommodative insufficiency (i.e., reduced response amplitude) and infacility (i.e., slowed dynamics). These investigations used objective recording techniques to assess therapeutically related anatomical and physiological changes in the accommodative system, which reflect system neuroplasty, as well as appropriate statistical analyses whenever possible.

The earliest study was performed by Liu et al.<sup>65</sup> in 1979. Three young adult patients with symptoms of blur during and/or immediately following short periods of nearwork were tested. A dynamic optometer integrated within a clinical slit-lamp, which directly measured anatomical crystalline lens movement and physiologically-related luminous flux changes in the central anterior region of the crystalline lens and anterior chamber, was used in the laboratory environment to assess accommodative dynamics pre- and post-accommodative vision therapy. Conventional home therapy was instituted over periods that ranged from 4 to 7 weeks for 20 minutes per day. The therapy consisted of step dioptric blur stimuli (i.e., jump focus and lens flippers) and ramp dioptric blur stimuli (i.e., pencil push-ups),<sup>1-3</sup> which is

consistent with the dynamic accommodative model and dual-mode accommodative control described earlier. Direct changes in crystalline lens response dynamics pre- and post-therapy are presented in Figures 9 and 10.



**Figure 10** Change of accommodative characteristics in the three subjects as measured weekly through changes in time constants ( ), latencies ( ), and flipper rates during their accommodative therapy program. Mean values are plotted for time constant and latency graphs, with standard errors denoted by the error bars. Flipper rates are self-reported by each subject (reprinted with permission from Liu et al., 1979).

The primary change was in the innervational and biomechanical aspect of the crystalline lens response time. This can be described and quantified using the bioengineering measure of "time constant," which refers to the time for an exponential response to attain 63% of its final steady-state amplitude.<sup>64</sup>

Clearly, the time constant for both increasing and decreasing accommodation reduced and normalized (Figure 10). The reduction in time constant suggested revision and improvement in the neuromotor control program,<sup>66</sup> thereby leading to a more-efficient and time-optimal response. Furthermore, a reduction in time constant means a greater rate of change of the anterior curvature of the lens with increasing or decreasing accommodation. That in turn implies either a greater rate of force output produced by the neuromuscular system of the ciliary muscle<sup>67</sup> and/or more-synchronized innervation. The accommodative latency, or reaction time—the time from stimulus onset to crystalline lens response onset—also normalized (Figure 10), although this parameter was only slightly abnormal (i.e., prolonged) initially. Reduction of latency means a shorter reaction time of the system, which may indicate more-efficient signal processing at the cortical level. Specifically, with respect to the dynamic accommodative model (Figure 7), these findings reflect changes in the threshold deadspace operator, derivative controller, time delay, and ciliary muscle/lens dynamics components. These objectively based measures, as well as the clinical lens flipper accommodative facility measure<sup>1-3</sup>—which are correlated with objective measures of overall accommodative dynamic responsivity (i.e., dynamic facility)<sup>68</sup>—were themselves positively correlated with marked reduction in the patients' nearwork symptoms.

In tandem with the above study, control experiments were independently performed.<sup>69</sup> Subjects included optometry students with accommodative insufficiency, patients with accommodative insufficiency who elected not to receive vision therapy, and visually normal individuals who underwent accommodative therapy. None exhibited any change in accommodative dynamics.

Four years later, the landmark Liu et al. (1979) investigation<sup>65</sup> was confirmed and extended by Bobier and Sivak<sup>70</sup> (1983) in five young adult patients who manifested nearwork-related blur symptoms and accommodative infacility. They used the objective laboratory technique of  $\rho$ , which assesses refractive-related, optical changes in the retinal reflection as observed in the plane of the pupil, similar to the standard clinical technique of  $\rho$ . Patients received 20 minutes of daily home therapy for 3 to 6 weeks, which consisted of monocular and binocular accommodative therapy (step dioptric blur stimuli). In addition to confirming the types of objective changes reported by Liu et al.<sup>65</sup> (as described earlier), they also found lack of regression of the positive therapy effect over the 4.5-month follow-up test period. Over the same period, no changes in accommodative dynamics were found in their control subject.

Three years later (1986), Hung, Ciuffreda, and Semmlow<sup>44</sup> assessed static (i.e., steady-state changes rather than the dynamic changes assessed in both the Liu et al.,<sup>65</sup> and Bobier and Sivak,<sup>70</sup> investigations described above) in 21 college students who reported visual symptoms of blur and intermittent diplopia after short periods of nearwork. They used a Hartinger coincidence refractometer to measure accommodation objectively via the Scheiner principle of optical vergence at the retina, and used a bioengineering model approach (Figures 3, 4, 5, and 6) to assess the individual component contribution changes overall global changes in accommodative responsivity resulting from the accommodative vision therapy. Accommodative therapy was performed both daily in the home (15 minutes/day; step dioptric blur stimuli) and weekly in the laboratory (30 minutes/session; ramp dioptric blur stimuli) for an average of 12 weeks.

These included tonic accommodation (system bias), slope of the accommodative stimulus/response function (the closed-loop system gain =  $\frac{ACG}{1+ACG}$ ) and the convergence-accommodation to convergence

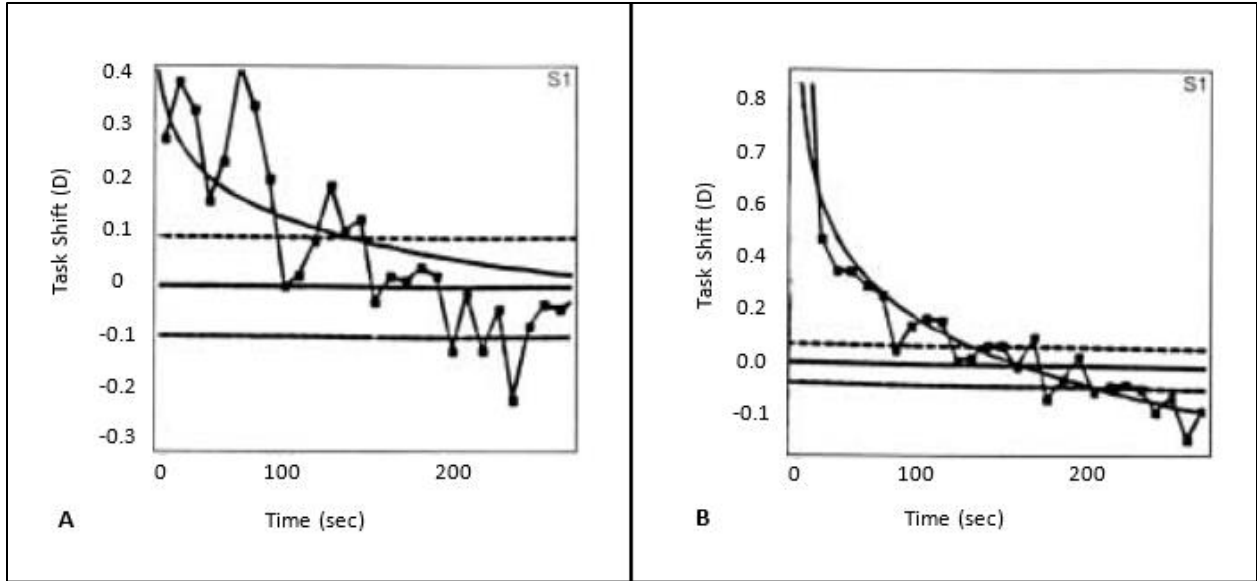
Ratio ( $\frac{CA}{CA}$  ratio; related to crosslink system gain CA). All of the above changes improved accuracy of the

steady-state accommodative responses at all distances, as well as clinical lens flipper accommodative facility improvement, which has been found to correlate well with overall lens dynamic responsivity determined objectively in both young adults<sup>65</sup> and children.<sup>68</sup>

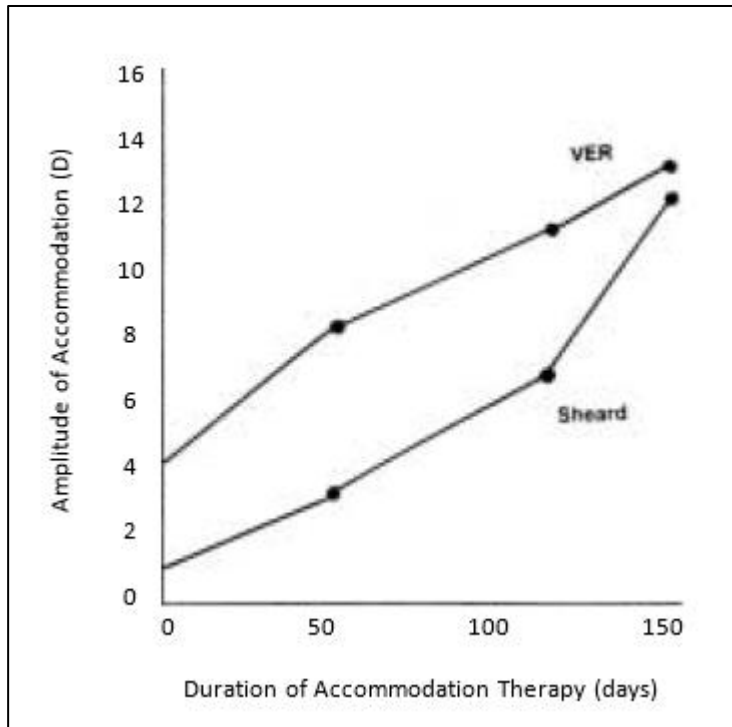
### **Other studies**

Many patients with accommodative dysfunction not only have symptoms at near, but also transient (5 seconds to 5 minutes) blur at distance following relatively short periods ( $\leq 15$  minutes) of nearwork.<sup>59</sup> This has been termed (NITM).<sup>53,59</sup> This anomalous accommodative after effect results from an inability to relax accommodation fully and rapidly in the distance in a time-optimal and efficient manner. This appears to reflect physiologically an abnormality of the sympathetic system<sup>59,71</sup> and neurologically increased gain ( $K_A$ ) of the adaptive loop.<sup>53</sup> This transient myopia has been linked to permanent myopia.<sup>53,59</sup> NITM can be conceptualized in clinical terms as reflecting a very mild accommodative spasm,<sup>59</sup> and in bioengineering terms as reflecting nonlinear accommodative dynamics and a hysteresis (i.e., an accommodative after effect) phenomenon.<sup>39</sup> Patients with NITM have responded favorably to conventional daily accommodative home therapy (20 minutes/day, 3 to 5 weeks; step dioptic blur-only stimuli and combined blur/disparity/proximal stimuli) and similar weekly laboratory therapy (10 minutes per session).<sup>62</sup> Using an objective, infra-red Canon R-1 autorefractor, including the grating focus principle, dynamic accommodative responses from near-to-far immediately after nearwork were found to normalize following this relatively short period of accommodative vision therapy. with the responses becoming more rapid and less variable. Complete results for one subject are presented in Figure 11. This objective finding again correlated with marked reduction in symptoms.

Taking a very different objective neurophysiological approach, Lovasik and Wiggins<sup>72</sup> (1984) measured and compared changes in accommodative amplitude with a standard subjective clinical technique (i.e., minus lens to blur)<sup>73</sup> as well as an objective laboratory technique (i.e., visually evoked cortical response),<sup>73</sup> which reflects the summed electrophysiological activity in the primary visual cortex. This was assessed in one patient with nearwork symptoms during the course of conventional accommodative therapy. There was a large and progressive correlated increase in measures over the 4-month vision therapy period ( Figure 12).



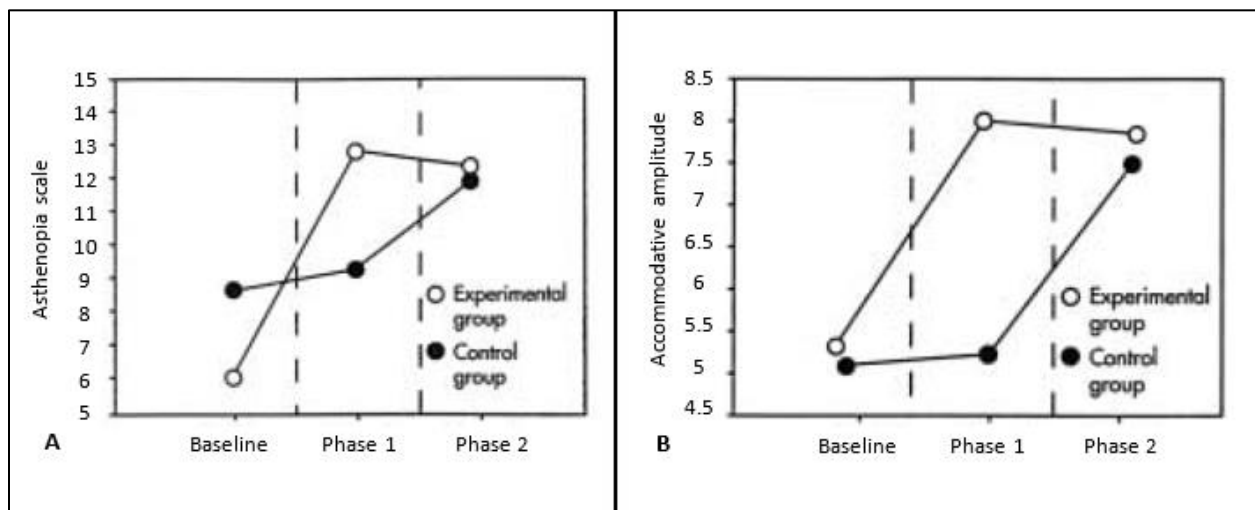
**Figure 11** NITM decay curves in a symptomatic patient, S1;  $\bullet$ , Pre-therapy and  $\circ$ , Post-therapy. Exponential curve fit.  $\pm$  SD about the normalized distance refraction ( $\bullet$ ). (From Ciuffreda and Ordonez, unpublished results).



**Figure 12** Changes in the amplitude of accommodation measured both objectively (VER) and subjectively (Sheard's technique of minus lens to blur) as a function of the duration of accommodation therapy. Note that while both techniques show a similar progressive increase in the amplitude of accommodation with therapy, the VER nearly always predicted a higher amplitude and showed good concordance with the Sheard value at the latest measurement (reprinted with permission from Lovasik and Wiggins, 1984).



An investigation by Cooper et al.<sup>74</sup> focused on changes in nearwork-related asthenopia with conventional accommodative vision therapy.<sup>1-3</sup> Eight young adult patients with combined accommodative insufficiency and infacility underwent computer-automated, monocular accommodative facility therapy in the clinic (6 weeks, 2 times/week for 30 minutes; steps of dioptric blur stimuli) using a matched-subjects, cross-over experimental design to control for placebo effects. All patients exhibited a marked reduction in nearwork-related asthenopia as assessed by a 5-point symptom rating scale questionnaire (Figure 13), as well as correlated increases in both clinical static accommodative amplitude (Figure 13) and dynamic accommodative facility. Hence, this relatively short period of accommodative vision therapy was sufficient to remedy both the patients' nearwork-related signs and symptoms. Statistically significant results were found that demonstrated true performance improvement related to the accommodative therapy. Furthermore, there was no such change during the cross-over control phase. Thus, those who received the control phase first exhibited no change, while those who received the control phase second exhibited maintenance of the initial positive therapeutic effect.



**Figure 13** Mean asthenopia scores are presented on the ordinate, whereas phases of testing are presented on the abscissa. (○) represent patients who received experimental therapy first; (●) represent those patients who received placebo therapy first (reprinted with permission from Cooper et al, 1983). The abscissa depicts the three phases of testing, i.e., baseline, phase 1, and phase 2. Mean accommodative amplitude for all patients in each phase (determined by minus lens to blur) is plotted on the ordinate. (○) represent patients who received experimental, accommodative training during phase 1 and placebo during phase 2. (●) represent patients who received the opposite condition, i.e., phase 1, control (placebo); phase 2, accommodative training (reprinted with permission from Cooper et al., 1983).

In a recent clinical study conducted in a Swedish ophthalmology department, Sterner et al.<sup>75</sup> tested and trained school-age children (n = 38; ages 9 to 13 years) who manifested accommodative dysfunction. Symptoms included asthenopia, headaches, blurred vision, and avoidance of nearwork. Accommodative facility therapy (i.e., lens flippers) was performed at home (15 minutes/day, typically for 8 weeks or less). Relative accommodation improved in all children, and all were now asymptomatic. In a two-year followup, 20 of the original 38 children agreed to participate in a telephone interview. All remained asymptomatic.

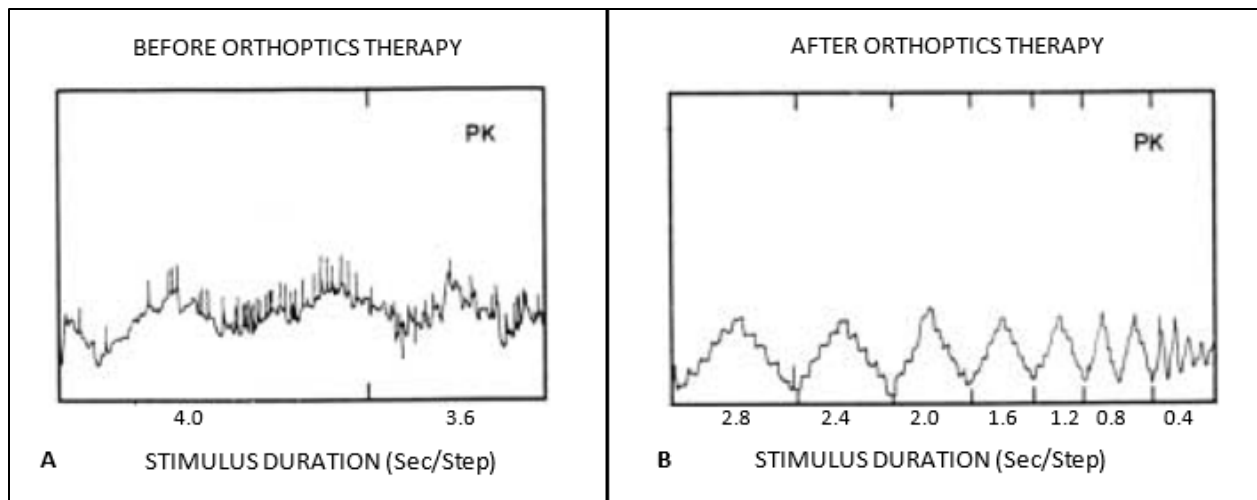
## Fusional vergence therapy

Therapy for fusional (i.e., disparity) vergence disorders has been recognized clinically for decades by both optometrists and ophthalmologists:

"Most recognized textbooks in the treatment of binocular vision disorders, including those of Duke-Elder, von Noorden and Burian, Hugonnler and Hugonnier, Lyle and Wybar, Dale, and Griffin recommend vision therapy, or orthoptics, as the preferred treatment option in cases of symptomatic convergence insufficiency. This unanimity of opinion is justified on the basis of over 1900 reported clinical cases assimilated during the last 47 years in which the average cure rate is 72%."<sup>76</sup>

### Primary studies

The seminal work in this area based on objective documentation was conducted by Grisham et al.<sup>77,78</sup> over the past two decades in two primary investigations. In both studies, objective recordings of horizontal fusional vergence eye movements were made. In addition, appropriate statistical analyses were incorporated whenever possible.

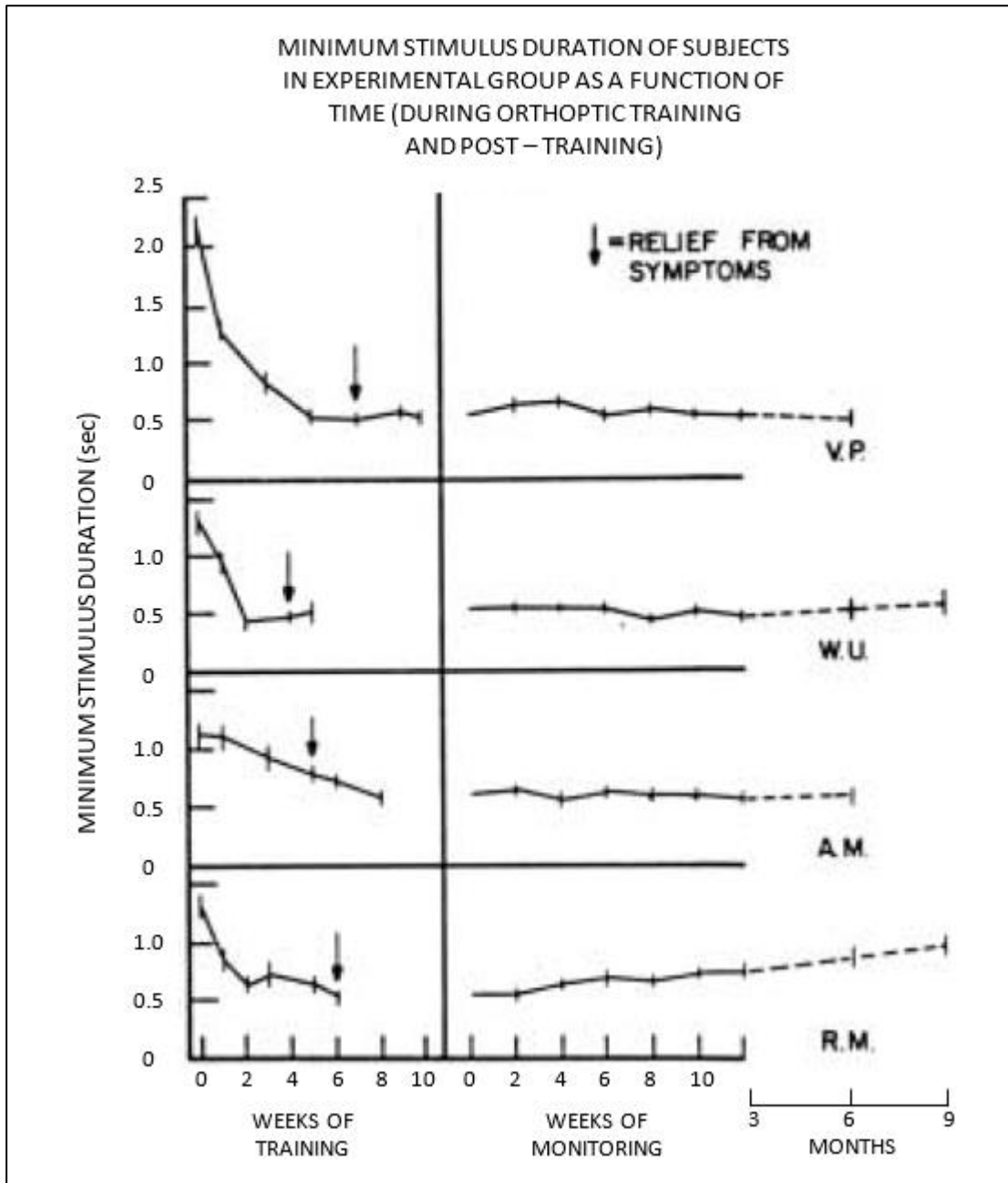


**Figure 14** Step vergence tracking recordings before and after orthoptics therapy. Before orthoptic therapy, subject PK could not adequately track a step vergence staircase stimulus changing at the rate of 4 sec/step. After 8 weeks of home orthoptic therapy, PK successfully tracked steps changing at the rate of 0.8 sec/step (reprinted with permission from Grisham et al., 1991).

In the first study (1980), Grisham<sup>77</sup> differentiated between asymptomatic normal patients ( $n = 4$ ) and those with symptoms related to fusional vergence dysfunction ( $n = 4$  to 14, depending on the experiment) based on statistically significant differences in their objectively based, dynamic fusional vergence oculomotor parameters. Test and therapy stimuli consisted of small steps (2 prism diopters) of convergent (10 prism diopter range) and divergent (10 prism diopter range) disparity centered about the heterophoria position with a variable rate of step input change, thus producing variable frequency "staircases" of disparate stimuli. Overall vergence tracking rate (analogous to clinical prism flipper vergence facility 1), percent completion of step responses, response velocity, and divergence response latency discriminated statistically between the two groups; only convergence response latency did not.

Given the above critical information, the key question remained to be answered in the laboratory environment using objective measures: "Does the fusional vergence system have sufficient plasticity to

alter and normalize its dynamic neuromotor response characteristics?" The second study (1991) by Grisham et al.<sup>78</sup> clearly provided a positive answer to this important question, which had its origins in the pioneering work of Javal (1858), an ophthalmologist and the "father of orthoptics."



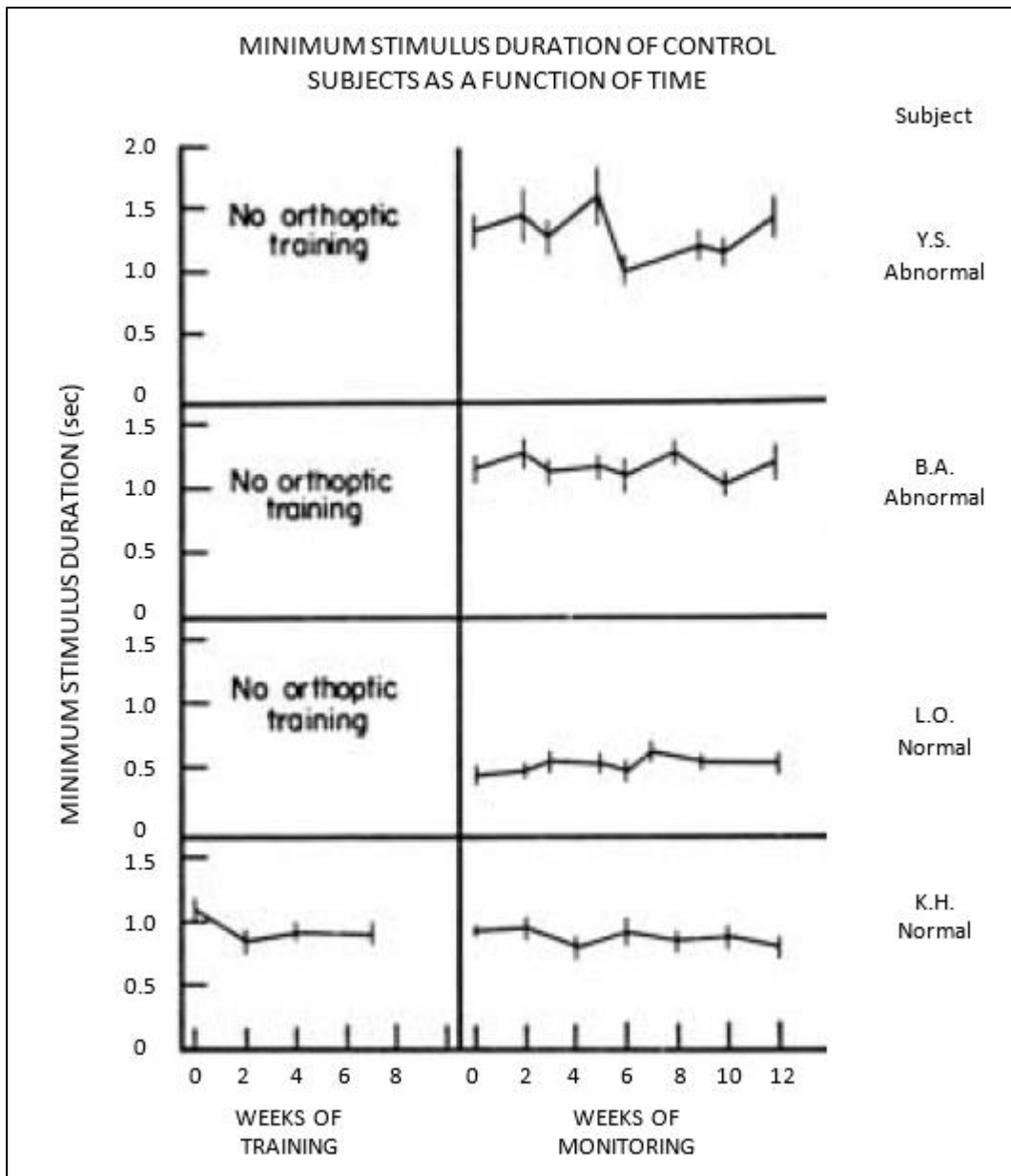
**Figure 15** The tracking rate of vergence-deficient subjects as a function of weeks of training and post-training monitoring. All subjects initially showed slow tracking rates that increased to maximum levels in 2 to 8 weeks of orthoptics therapy. All subjects, except for RM, maintained their maximum tracking rate over the post-therapy period of monitoring. The (|) indicates the measurement standard error (reprinted with permission from Grisham et al., 1991).

Using a stimulus system and objective infra-red eye movement system similar to that used in the aforementioned study, they first tested patients ( = 3 to 6, depending on the experiment) with nearwork-related visual discomfort and clinical signs of convergence insufficiency. A variety of standard clinical vergence and accommodative therapy techniques<sup>1-3</sup> that involved both step and ramp disparity stimuli were assigned to each patient (8 weeks, 30 minute/day at home). Post-therapeutic objective changes in their fusional vergence eye movements were striking. Figure 14 shows overall fusional vergence tracking to small steps of disparity before and after therapy. Before fusional vergence therapy, only a very slow stimulus rate of change could be followed, and that was poorly executed using small and variable amplitude responses. By contrast, following therapy, the fusional vergence responses were full, and tracking rate was remarkably increased (about 10-fold). These improvements reflected changes in dynamic vergence model parameters analogous to those suggested earlier with respect to accommodation dynamics. The striking vergence improvements were correlated with marked reduction in symptoms, as well as normalization of related clinical findings. Positive therapy results did not show evidence of regression over the 6- to 9-month follow-up period in most cases ( Figure 15). And there were no changes in the control group monitored over a similar time course ( Figure 16).

### **Other studies**

Another model-based fusional vergence parameter is "vergence adaptation"<sup>79</sup> ( Figures 4 and 5). It is believed to be critical for a range of vergence functions,<sup>79</sup> (e.g., maintaining a stable phoria position<sup>80</sup> in the presence of changes in disparity stimulation, fatigue effects, illness, etc.). Such changes may occur either transiently or over more-sustained periods of time, such as during prolonged nearwork. Using oculomotor model-driven investigations that incorporated psychophysical test procedures, North and Henson<sup>81</sup> found that vergence adaptation discriminated well between symptomatic and asymptomatic patients who manifested nonstrabismic vergence dysfunctions. In a later study, they—like Grisham et al.<sup>77,78</sup>—assessed vision therapy-related plasticity of this specific oculomotor component.<sup>82,83</sup> Seven young adult patients with symptomatic convergence insufficiency and abnormal vergence adaptation received daily vergence optometric vision therapy at home for 8 weeks (push-ups, physiological diplopia awareness, and relative positive fusional vergence disparity stimulation). Before therapy, responses were poor and outside normal limits.

Furthermore, symptoms markedly reduced and related clinical findings normalized. In contrast, in the normal control group ( = 6), there was no statistically significant change in vergence adaptation(+ 4.8%).



**Figure 16** The vergence tracking rate of control subjects as a function of weeks of training and/or monitoring. Two vergence-deficient subjects and one normal subject were monitored for 12 weeks and showed no overall change in their vergence tracking rates. One normal subject, who was trained, showed a small but significant increase in tracking rate that persisted during the monitoring period. The (|) indicates the measurement standard error (reprinted with permission from Grisham et al., 1991).

Lastly, as they did for accommodative optometric vision therapy described earlier, Cooper et al.<sup>84</sup> formally investigated therapeutically related changes in asthenopia in seven young adult patients with symptomatic convergence insufficiency using a matched-subjects, control group, cross-over experimental design to minimize placebo effects. Following clinical testing and the diagnosis of convergence insufficiency, the patients initially underwent computer-automated (random-dot stereograms with controlled, variable vergence demands), and then conventional (accommodative, fusional, and stereographic procedures) fusional vergence therapy (100 trials per session; 1 session per

week for at least 8 weeks per phase). The vergence stimulus demand was progressively increased automatically by the computer program, based on the patient's rate of improved performance. In the experimental phase, there were statistically significant improvements in the fusible stereogram stimulus range, as well as asthenopia reduction as assessed with their 5-point symptom-rating questionnaire. Furthermore, other abnormal clinical vergence-related findings (such as fixation disparity) normalized with vision therapy.

## Discussion

In this article, selected literature has been reviewed that provides supportive evidence of the scientific basis for and efficacy of optometric vision therapy in the areas of nonstrabismic accommodative and vergence disorders. The supporting evidence is manifold, including objective physiological measures, symptom rating-scale questionnaire confirmation, statistical verification, oculomotor model-based bioengineering quantitative approaches, cross-over experimental designs in clinical studies, and correlated and positive clinical test findings. Furthermore, when the above information is combined with the numerous case reports/case studies, and retrospective/prospective investigations summarized and reviewed in the optometric, ophthalmologic, and orthoptic literatures,<sup>26,32-36</sup> and if one adopts a more global,<sup>85</sup> the evidence in support of optometric vision therapy in patients who manifest symptomatic, nonstrabismic vergence and accommodative disorders is even stronger.

Numerous examples of how these models have been used to provide new insights regarding diagnostic aspects of static and dynamic accommodative and vergence oculomotor anomalies and their specific abnormal model-based subcomponents, as well as the effectiveness of specific therapeutic subcomponent targeting, have been enumerated and detailed.

Let us reinforce this notion using a specific case example. Suppose an adolescent patient exhibits reduced (by 1 D) steady-state accommodation at near under binocular viewing conditions as assessed by dynamic retinoscopy.<sup>73</sup> Several possible individual static model components may be involved (Figures 3, 4, and 5), such as the depth-of-focus, accommodative controller gain, adaptive gain, tonic accommodation, proximal accommodation, and convergence accommodation. The magnitude of vergence accommodation is typically relatively minor, as most of a system's response output is derived from the specific stimulus drive (i.e., blur) within its own negative feedback control loop. Under normal binocular viewing conditions—with both the accommodative and vergence negative feedback control loops in their closed-loop mode, such that blur and disparity information, respectively, are effective—the proximal and tonic terms are negligible, especially at near. Since one is not dealing with sustained (i.e., minutes) accommodation at near, the adaptive loop would not be activated. Thus, one is left with two components; namely, depth-of-focus and accommodative controller gain. It can be difficult to disentangle their individual component effects on steady-state accommodation, as their typical abnormal dynamic accommodative retinoscopy response would independently result in reduced static accommodative levels. Assuming a high state of attention and motivation during the diagnostic testing—and in the absence of more-severe ocular conditions such as amblyopia and nystagmus—the anticipated increased amount of depth-of-focus might only be 0.25 D or so, which is considerably less than the 1.0 D lag of accommodation uncovered at near clinically. Hence, the accommodative controller gain component would be responsible for contributing the residual amount. Thus, vision therapy would incorporate blur discrimination techniques (e.g., sequential lens sorting<sup>55</sup>) to sensitize and normalize the neurosensory aspects of the depth-of-focus. However—and perhaps even more

importantly—monocular and binocular lens flipper therapy using slightly-above-threshold visual acuity letter targets (or perhaps low-contrast gratings) would also be used to force more-accurate accommodation (and thus larger response amplitudes), which translates into normalization of the accommodative controller gain parameter. While additional therapeutic procedures would still be used, only specific ones would be emphasized, perhaps with various degrees of "weighting."

<b>Model component</b>	<b>Probable neural sites</b>
<b>Depth-of-focus (DF)</b>	<b>Areas V1, V2 visual cortex (sensory; contrast detectors)</b>
<b>Panum’s fusional areas (PFA)</b>	<b>Areas V1, V2 visual cortex (sensory; disparity detectors)</b>
<b>Controller gain (ACG; VCG)</b>	<b>Midbrain (motor near response cells)</b>
<b>Crosslink gain (AC; CA)</b>	<b>Midbrain</b>
<b>Adaptive gain (ADAPT)</b>	<b>Cerebellum; Neuroreceptors of ciliary body</b>
<b>Tonic innervation (TA; TV)</b>	<b>Midbrain</b>

As mentioned at the beginning of the model section, a good model should have neuroanatomic and neurophysiologic under-pinnings. Thus, it should be homeomorphic in nature. At this time, some of this information is not fully understood. With recent advances in brain-imaging technology, however, answers to these critical questions should be forthcoming. Within these constraints, an attempt has been made to relate the static and dynamic model components to possible sensory and motor neural sites of involvement (Table 2). However, additional brain areas are probably involved in dissemination of this information in a more-complex and comprehensive neural network.<sup>51,61,62</sup>

A primary thrust of this article has been on those studies that have used objective measures of accommodative and vergence responsivity before and after therapy, as well as in some cases during specific therapeutic phases.

**Motor learning and motor planning**

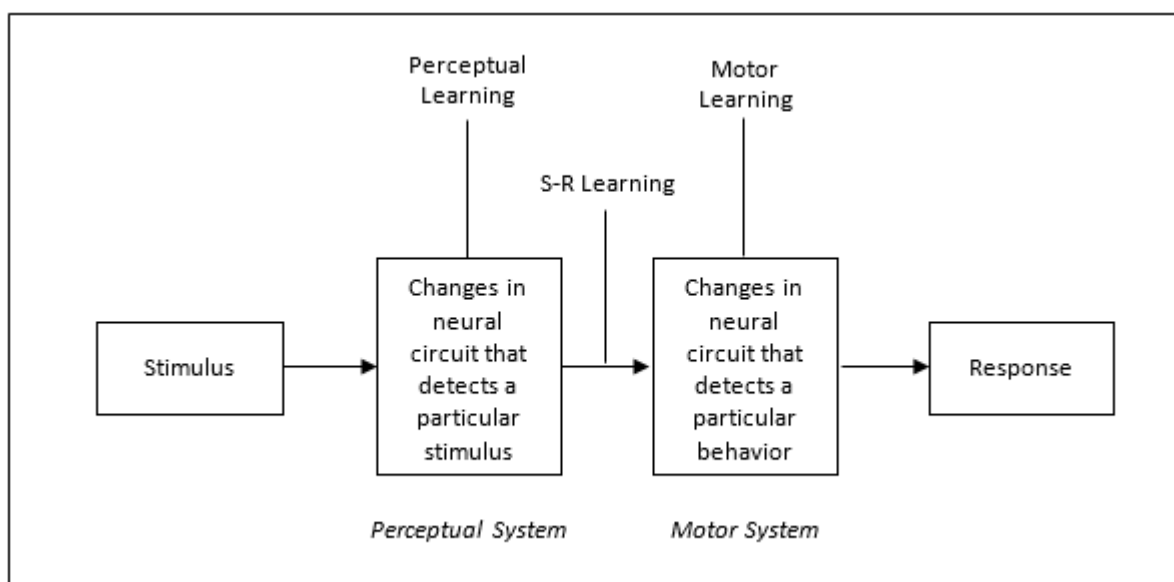
(i.e., perceptual-motor skill acquisition) involves describing and explaining changes in motor performance and motor control that occur with specific practice paradigms.<sup>19</sup> Acquiring new (or altering old) motor skills takes place in three well-defined phases.

1. : This primarily involves conscious thinking and planning of movement strategies; hence, one either learns new movement patterns, or reshapes old ones. via a trial-and-error approach. Initial performance varies considerably as a range of movement strategies is attempted, with most being discarded in favor of the most-effective and efficient one.

2. : This single, new movement pattern is practiced repeatedly and "fine-tuned." When the movement pattern is learned reasonably well, increases in task complexity and changes in prevailing conditions are instituted to ensure task success and systematic continuation of motor skill development.
3. : The highly practiced movement pattern, or motor skill, has become automatic and below the level of consciousness. Motor performance is consistent, precise, efficient, "time-optimal," and accurate. Hence, the motor pattern becomes "pre-programmed" and, in essence, "open-loop" (i.e., without the need to consciously monitor its feedback). This is in contrast to the earlier two phases. in which feedback is essential and continuously monitored (i.e., closed-loop) to Improve motor performance.

The above description of motor skill acquisition must be learned for each new motor skill. There is relatively little transfer.

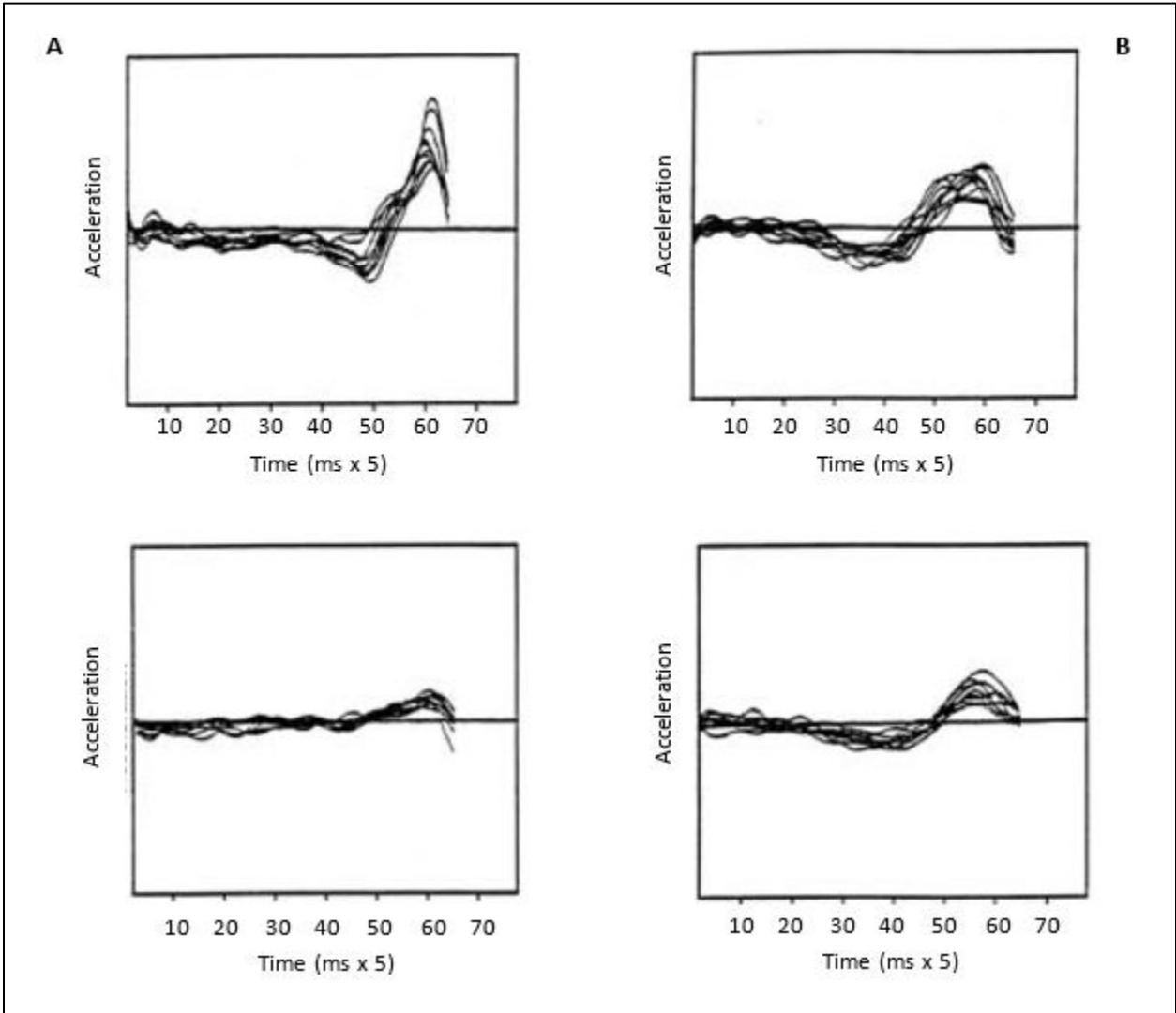
These principles of motor learning can be conceptualized mechanistically in a global manner (as shown In Figure 17, which presents the classical psychology "stimulus-response" paradigm).<sup>86</sup> It can be further appreciated in the dynamic motor response patterns (response acceleration as a function of time) comparing a novice versus expert squash player (Figure 18).<sup>87</sup> What is referred to as greater "consistency" for the expert player can be translated into the more-general neurological principle of neural signal "synchronization."<sup>19,88-90</sup> With appropriate practice and repetition, there is more synchronous firing in the group of motor neurons controlling the muscles involved in a specific movement. Greater mass neuronal synchrony translates into greater motor response consistency and time optimality.<sup>67</sup> Clearly, this idea can be transferred to optometric vision therapy for nonstrabismic accommodative and vergence disorders. One would use monocular lens flipper techniques, wherein only monocular accommodative neural control is conditioned and shaped, then fusional vergence in isolation using prism flippers and a blur-free DOG (difference of Gaussians) stimulus,<sup>60,61</sup> followed by a similar process involving binocular interactive closed-loop aspects of the accommodative and vergence systems in the dynamic free-space environment.





**Figure 17** Schematic view of the different types of learning examined by neurophysiologists (Reprinted with permission from Carlson, 1994).

Lastly, one can proceed to the synaptic and molecular level of motor learning. This was first enunciated by Hebb in 1949<sup>91</sup> within the context of his now-classic notion of "cell assemblies," the predecessor to contemporary "neural networks."<sup>92</sup> He stated, "...when an axon of Cell A is near enough to Cell B and repeatedly or persistently takes part in firing it, some growth processes or metabolic changes take place in one or both cells such that A's efficiency, as one of the cells firing B, is increased." Hence, by repetition, patterns of neural activation of specific neurons and their inter-connections are enhanced, whereas those without such correlated patterns of activity are weakened. This neural enhancement, in effect, produces relatively long-term neural "potentiation," such that a certain level of neural activation now produces increased cell responsivity, which suggests the efficiency of synapses has been enhanced via the repetitive motor learning process. Current research is focused on determining which neuroreceptor is involved in such learning, with the N-methyl-D-aspartate (NMDA) receptor appearing to be a likely candidate.<sup>92</sup>



**Figure 18** Acceleration-time curves from an expert ( ) and a novice ( ) squash player executing 10 fast strokes ( ) and 10 slow strokes ( ). The greater consistency of the expert is particularly evident for the slow strokes. (Reprinted with permission from Wollstein and Abernethy, 1988).

### Future directions

While there is considerable evidence for the scientific basis and efficacy of optometric vision therapy, as in any clinical discipline, more research and advances are welcome to understand the basic mechanisms more comprehensively, and to further enhance the results of clinical interventions. This includes:

1. Not all patients will respond similarly to the same vision therapy paradigm. It will be important to determine how the subgroups differ, and why, and then to develop more-specific therapeutic paradigms, resulting in greater success levels. Clearly, given the high prevalence of these nonstrabismic accommodative and vergence disorders and their related symptoms in the general optometric clinic, as well as their apparent ease of remediation via optometric intervention, the public health impact is enormous. Furthermore, it behooves all parties involved in providing and managing vision health care to lend support for such endeavors.
2. Such information will not only provide critical insights into the basic neural mechanisms involved, but may also help develop more-specific and "targeted" therapeutic paradigms.
3. (Item 2). This would include functional MRI,<sup>93</sup> magnetoencephalography (MEG),<sup>67</sup> and positron emission tomography (PET)<sup>94,95</sup> non-invasive brain-imaging techniques to localize the basic neural sites involved in the clinical abnormality, as well as those that contribute to the oculomotor therapeutic changes reflecting oculomotor learning and plasticity.
4. <sup>86,92,96,97</sup> as pioneered by the classic Hebbian notion.<sup>91</sup>

### Acknowledgments

This document was funded in part by a grant from the Mountain States Congress of Optometry, in association with the American Optometric Association. I wish to thank Drs. Jeffrey Cooper, Sue Cotter, Esther Han, George Hung, Neera Kapoor, Leonard Press, Michael Rouse, Mitchell Scheiman, Irwin Suchoff, Barry Tannen, and Gary Williams for their helpful and insightful discussions and comments.

### References

1. Griffin JR, Grisham JD, 3<sup>rd</sup> ed. Boston: Butterworth-Heinemann, 1995.
2. Rutstein RP, Daum KM. St. Louis: Mosby, 1998.
3. Press LJ, ed. St. Louis: Mosby, 1997.
4. Cornell E, Mitchell R. An evaluation of proximal convergence by the use of infra-red photography. 1979-1980;17:24-9.
5. Ciuffreda KJ, Goldrich SG. Oculomotor biofeedback therapy. 1983;5:111-7.
6. Scheiman MM, Peli E, Libassi D. Auditory biofeedback used to enhance convergence insufficiency. 1983;54:1001-3.
7. Groffman S. Operant conditioning and vision training. 1969;46:583-94.

8. Letourneau JE. Application of biofeedback and behavior modification technique In visual training. 1976;53:187-90.
9. Feldman J. Behavior modification In vision training: facilitating prerequisite behaviors and skills. 1981;52:329-40.
10. Malmstrom FV, Randle RJ. Effects of visual imagery on the accommodative response. 1976;19:450-3.
11. Forrest EB. Duncan, Okla.: OEP Foundation, 1981.
12. Richman JE. The influence of visual attention and automaticity on the diagnosis and treatment of clinical oculomotor, accommodative. and vergence dysfunctions. 1999;30:132-41.
13. Lie I, Watten R, Fostervold KI. Accommodation/vergence/fixation disparity and synergism of head, neck and shoulders. In: Franzen O, Richter H, Stark L, eds. Basel, Switzerland: Birkhauser Verlag, 2000:303-12.
14. Han Y, Lennerstrand G. Effect of neck muscle proprioceptive activation on the dynamics of monocularly-driven horizontal vergence movements. 1998;76:283-8.
15. Servos P, Goodale MA, Jakobsen LS. The role of binocular vision in prehension: a kinematic analysis. 1992;32:1513-21.
16. Howard IP. Templeton WB. London: Wiley and Sons, 1966.
17. Suchoff IB. New York: SUNY/State College of Optometry, 1974.
18. Kelso JAS, ed. Hillsdale, N.J.: Lawrence Erlbaum Assoc. Pub, 1982.
19. Abernathy B, Kipper V, Mackinnon LT, et al. Champaign, ill.: Human Kinetics Pub, 1997:269-352.
20. Kephart NC. Ohio: C.E. Merrill Books, 1960.
21. Classé JG, Rutstein RP. Binocular vision anomalies: an emerging cause of malpractice claims. 1995;66:305-9.
22. Hokoda SC. General binocular dysfunction In an urban optometry clinic. 1985;56:560-2.
23. Hoffman L, Cohen AH, Feuer G. Effectiveness of optometric vision therapy/orthoptics In a private practice. 1973;50:813-6.
24. Cooper J, Duckman R. Convergence Insufficiency; Incidence, diagnosis, and treatment. 1978;49:673-80.
25. Scheiman M, Gallaway M, Goutier M, et al. Prevalence of vision and ocular disease conditions in a clinical pediatric practice. 1996;67:193-202.
26. American Optometric Association Consensus Panel with Accommodative and Vergence Dysfunction. Care of the Patient with Accommodative and Vergence Dysfunction. Optometric Clinical Practice Guidelines. St. Louis: AOA, 1998.
27. Scheiman MM, Wick B. Philadelphia: JB Lippincott, 1994.

28. Amos JF, Rutstein RP. Vertical deviations. In: Amos JF, ed. Boston: Butterworth, 1987:515-83.
29. Skeffington AM. Chicago: Al Fox Co., 1928.
30. Peckham RH. New York: Shur-On Standard Optical, 1928.
31. Duane A. Anomalies of the accommodation, considered clinically. 1915;14:386-402.
32. American Optometric Association. Position statement on vision therapy. 1985;56:782-3.
33. The 1986/87 Future of Visual Development/Performance Task Force. The efficacy of optometric vision therapy. 1988;59:95-105.
34. Joint Organizational Policy Statement of the American Academy of Optometry and the American Optometric Association. Vision therapy. 1999;10:109-10.
35. Suchoff IB, Petito GT. The efficacy of visual therapy: accommodative disorders and nonstrabismic anomalies of binocular vision. 1986;57:119-25.
36. Birnbaum MH. Boston: Butterworth-Heinemann, 1993:381-93.
37. Westhelmer G. Amphetamine, barbiturates, and accommodative vergence. 1963;70:830-6.
38. Toates FM. Accommodation and convergence in the human eye. 1969;3:29-33.
39. Stark L. New York: Plenum Press, 1968.
40. Saladin JJ. Interpretation of divergent oculomotor imbalance through control systems analysis. 1988;65:439-47.
41. Jiang BC. A modified control model for steady-state accommodation. In: Franzen O, Richter H, Stark L, eds. . Basel, Switzerland: Birkhauser Verlag, 2000:235-43.
42. Krishnan VV, Stark L. A heuristic model of the human vergence eye movement system. 1977;24:44-9.
43. Krishnan VV, Stark L. Integral control in accommodation. 1975;4:237-45.
44. Hung GK, Ciuffreda KJ, Semmlow JL. Static vergence and accommodation: population norms and orthoptics effect. 1986;62:165-79.
45. Hung GK, Semmlow JL, Ciuffreda KJ. A dual-mode dynamic model of the vergence eye movement system. 1986;33:1021-8.
46. Hung GK, Semmlow JL. Static behavior of accommodation and vergence: computer simulation of an interactive dual feedback system. 1980;27:439-47.
47. Hung GK, Ciuffreda KJ, Rosenfield M. Proximal contribution to a linear static model of accommodation and vergence. 1996;16:31-41.
48. Hung GK, Ciuffreda KJ. Dual-mode behavior in the human accommodation system. 1988;8:327-32.
49. Hung GK, Ciuffreda KJ. Sensitivity analysis of relative accommodation and vergence. 1994;41:241-8.

50. Schor C, Homer D. Adaptation disorders of accommodation and vergence in binocular dysfunction. 1989;9:264-8.
51. Schor C, Ciuffreda KJ, eds. Boston: Butterworth, 1983.
52. Schor CM. The relationship between fusional vergence eye movements and fixation disparity. 1979;19:1359-67.
53. Hung GK, Ciuffreda KJ. Adaptation model of nearwork- induced transient myopia. 1999;19:151-8.
54. Hung GK, Ciuffreda KJ, Semmlow JL, et al. Model of static accommodative behavior in human amblyopia. 1983;30:665-72.
55. Ciuffreda KJ, Levi D, Selenow A. Boston: Butterworth, 1991.
56. Ciuffreda KJ, Hokoda SC, Hung GK, et al. Accommodative stimulus/response function in human amblyopia. 1984;56:303-26.
57. Ong E, Ciuffreda KJ, Tannen B. Static accommodation in congenital nystagmus. 1993;34:194-204.
58. Hung GK, Ciuffreda KJ. A unifying theory of refractive error development. 2000;62:1087-108.
59. Ong EO, Ciuffreda KJ. Santa Ana, Calif.: OEP Foundation Press, 1997.
60. Ciuffreda KJ. Accommodation and its anomalies. In: Charman WN, ed. New York: MacMillan, 1991:231-79.
61. Ciuffreda KJ. Accommodation, the pupil, and presbyopia. In: Benjamin WJ, ed. Philadelphia: WB Saunders Co., 1998:77-120.
62. Ciuffreda KJ, Ordonez X. Vision therapy to reduce abnormal nearwork-induced transient myopia. 1998;75:311-5.
63. Mays LE, Gamlin PDR. Neuronal circuits for accommodation and vergence in the primate. In: Franzen O, Richter H, Stark L, eds. Basel, Switzerland: Birkhauser Verlag, 2000:1-9.
64. Bogart TF Jr. New York: John Wiley and Sons, 1982:73-4
65. Liu JS, Lee M, Jang J, et al. Objective assessment of accommodation orthoptics: dynamic insufficiency. 1979;56:285-94.
66. Gottlieb GL, Corcos DM, Jarle S, et al. Practice improves even the simplest movements. 1988;73:436-40.
67. Takeda T, Endo H, Hashimoto K. Research on dynamic accommodation using TDO III (three dimensional optometer III) and MEG (magnetoencephalography). In: Franzen O, Richter H, Stark L, eds. Basel, Switzerland: Birkhauser Verlag, 2000:51-66.
68. Mah MM, Pope RS, Wong JH. University of California (Berkeley): School of Optometry, O.D. thesis, 1981.
69. Liu J, Lee M, Jang J. University of California (Berkeley): School of Optometry, O.D. thesis, 1978.

70. Bobier WR, Sivak JG. Orthoptic treatment of subjects showing slow accommodative response. 1983;60:678-87.
71. Rosenfield M, Gilmartin B. Temporal aspects of accommodative adaptation. 1989;66:229-34.
72. Lovasik JV, Wiggins R. Cortical indices of impaired ocular accommodation and associated convergence mechanisms. 1984;61:150-9.
73. Benjamin WJ, ed. Philadelphia, WB Saunders Co., 1998.
74. Cooper J, Feldman J, Selenow A, et al. Reduction of asthenopia after accommodative facility training. 1987;64:430-6.
75. Sterner B, Abrahamsson M, Anders S. Accommodative facility training with a long-term follow up in a sample of school-aged children showing accommodative dysfunction. 1999;99:93-101.
76. Grisham JD. Visual therapy results for convergence insufficiency: a literature review. 1988;65:448-54.
77. Grisham JD. The dynamics of fusional vergence eye movements In binocular dysfunction. 1980;57:645-55.
78. Grisham JD, Bowman MC, Owyang LA, et al. Vergence orthoptics: validity and persistence of the training effect. 1991;68:441-51.
79. Cooper J. Clinical implications of vergence adaptation. 1992;69:300-7.
80. McCormack GL. Vergence adaptation maintains heterophoria In normal binocular vision. 1985;62:555-61.
81. North R, Henson DB. Adaptation to prism-induced heterophoria in subjects with abnormal binocular vision or asthenopia. 1981;58:746-52.
82. North R, Henson DR The effect of orthoptic treatment upon the ability of patients to adapt to prism-Induced heterophoria. 1982;59:983-6.
83. North R, Henson DR The effect of orthoptic treatment upon the vergence adaptation mechanism. 1992;69:294-9.
84. Cooper J, Selenow A, Ciuffreda KJ, et al. Reduction of asthenopia in patients with convergence insufficiency after fusional vergence training. 1983;60:982-9.
85. Glass GV. Primary, secondary, and meta-analysis of research. 1976;5:3-8.
86. Carlson NR. Boston: Allyn and Bacon Inc., 1997:576-608.
87. Wollstein JJ, Abernethy B. Timing structure In squash strokes: further evidence for the operational timing hypothesis. 1988;15:70-1.
88. Smith KU, Schmidt J, Putz V. Binocular coordination: feedback synchronization of eye movements for space perception. 1970;47:679-89.

89. Singer W. Synchronization of cortical activity and its putative role In Information processing and learning. 1993;55:349-74.
90. Singer W. Time as coding in neocortical processing. In: Buzsaki G, Llinas R, Singer W. et al., eds. Berlin: Springer Verlag, 1994:51-79.
91. Hebb DO. New York: John Wiley and Sons Inc., 1949.
92. Rauschecker JP. Mechanisms of visual plasticity: Hebb synapses, NMDA receptors, and beyond. 1991;71:587-615.
93. Ellermann JM, Siegal JD, Strupp JP. et al. Activation of visuomotor systems during visually-guided movements: a functional MRI study. 1998;131:272-85.
94. Richter H, Lee JT, Pardo JY. Neuroanatomical correlates of the near response: voluntary modulation of accommodation in the human visual system. In: Franzen O, Richter H, Stark L, eds. Basel, Switzerland: Birkhauser Verlag, 2000:67-78.
95. Pardo JV, Sponheim SR, Costello P, et al. Functional neuroanatomy of the human near/far response of the visual system to blur cues: fMRI to point targets at different viewing distances. In: Franzen O, Richter H, Stark L, eds. Basel, Switzerland: Birkhauser Verlag, 2000:79-90.
96. Daw NW. New York, Plenum Press 1995:155-92.
97. Windhorst U. Specific networks of the cerebral cortex: functional organization and plasticity. In: Greger R, Windhorst U, eds., Vol. 1. Berlin: Springer-Verlag, 1996:1105-36.
98. Cooper J. Review of computerized orthoptics with specific regard to convergence Insufficiency. 1988;65:455-63.
99. Cooper J. Diagnosis and treatment of accommodative and vergence anomalies using computerized vision therapy. 1998;9(1):6-11.

**Corresponding author:**

Kenneth J. Ciuffreda, O.D., Ph.D.  
State University of New York  
State College of Optometry  
33 West 42nd Street  
New York, New York 10036